

## INVITATION TO BID

**Bid Name:** Irongate Phase 2 Project Sealed Bids

**Description:** Dorchester County, South Carolina invites sealed bids to provide the installation of stormwater pipe and boxes to alleviate flooding conditions at the rear of properties on Ravenswood Court, Irongate Subdivision and extending through HOA property of Brandymill Subdivision discharging into Sawmill Branch.

**Bid Notice Number:** 2017-3183-4520-32

**Closing Date/Time:** Thursday, May 18, 2017 at 4:00 P.M., local time

**Bid Opening:** Dorchester County Purchasing Department  
201 Johnston Street  
St. George, SC 29477  
S.G. Stephens, Jr., CPPO, Procurement Director

**Specifications/Construction Plans:** Available on the Dorchester County Purchasing Department E-Procurement website (<http://bids.dorchestercounty.net>) after bidder registration. For questions on registration call the Purchasing Department at (843) 563-0142 or 832-0142.

**E-Mail:** [sstephensjr@dorchestercounty.net](mailto:sstephensjr@dorchestercounty.net)

**Award:** Notification of successful bidder will be posted on the County website: [www.dorchestercounty.net](http://www.dorchestercounty.net) (Select Purchasing Department from drop down)

**Vendor Registration:** <http://bids.dorchestercounty.net>

Vendors that have not registered are to go to the above website, register and then download the bid documents-**Commodity Code 4500** .

**Project Contact:** Mike Goldston, Engineering Manager

**Website:** <http://bids.dorchestercounty.net>

DEADLINE FOR WRITTEN QUESTIONS (on module) IS THURSDAY, MAY 11, 2017 AT 5:00 PM.



**Dorchester County Purchasing**

Procurement Director  
201 Johnston Street  
St. George, South Carolina 29477

Telephone (843) 563-0142 or 832-0142  
Fax (843) 563-0152 or 832-0152

April 29, 2017

Re: Irongate Phase 2 Project Sealed Bids – 4:00 PM, Thursday, May 18, 2017  
Project Number 2017-3183-4520-32

Dear Bidder:

Please refer to the enclosed bid package for the above referenced project. Any questions concerning the bid specifications should be directed to the Procurement Module-<http://bids.dorchestercounty.net>. If you are unable to bid on this project, please indicate on the enclosed form and return to my office.

Provide original, one copy, and one electronic copy (flash drive or CD) of your bid. Notification of the successful bidder will be posted on the County website: [www.dorchestercounty.net](http://www.dorchestercounty.net) .

Thank you for your participation.

Sincerely,

S.G. Stephens, Jr., CPPO  
Procurement Director

/sgs  
Bid Package

## NO RESPONSE

If a "No Response" is to be submitted, please check the appropriate box or boxes below and return this form, prior to the due date, to: Dorchester County Purchasing Department, 201 Johnston Street, St. George, South Carolina 29477.

Cannot respond to solicitation \_\_\_\_\_ due to the following reason:

- Do not sell or provide the requested goods or services
- Cannot comply with specifications/statement of work
- Specifications/statement of work is unclear
- Cannot meet delivery or period of performance
- Delivery/period of performance is unreasonable
- Cannot meet the bond requirements
  
- Not enough time to prepare proposal
- Plan to subcontract
- Job is too large
- Job is too small
- Other (please specify) \_\_\_\_\_

Company: \_\_\_\_\_

Phone/Fax: \_\_\_\_\_

Representative: \_\_\_\_\_

Signature: \_\_\_\_\_

**INVITATION TO BID**  
**STIG17**  
**Bid Number 2017-3183-4520-32**

Dorchester County, South Carolina invites sealed bids from qualified contractors for the installation of stormwater pipe and boxes to alleviate flooding conditions at the rear of properties on Ravenswood Court, Irongate Subdivision and extending through HOA property of Brandymill Subdivision discharging into Sawmill Branch.

Sealed bids will be received until 4:00 PM, May 18, 2017 at the Office of the Procurement Director, Dorchester County Services Facility, 201 Johnston Street, St. George, South Carolina 29477. **BIDS RECEIVED AFTER 4:00 PM, MAY 18, 2017 WILL NOT BE CONSIDERED.**

Bid shall be clearly marked, "Irongate Phase 2 Project Sealed Bid-Do Not Open". Specifications may be obtained by registering as a vendor on the purchasing webpage at <http://bids.dorchestercounty.net> , and then logging in. Commodity Code: 4500

All bids will be publicly opened at 4:00 PM, May 18, 2017 in the Purchasing Department. Dorchester County reserves the right to reject any or all bids and to waive minor deficiencies, informalities, and technicalities, when, in the judgment of County Council, the best interests of the County would be served.

**THIS IS NOT AN ORDER**

\*VENDOR ORIGINAL

\*ONE VENDOR ORIGINAL & ONE VENDOR COPY TO BE

\*VENDOR COPY

Dates Advertised:

SUBMITTED BY EACH BIDDER

Page 1 of Pages     

 <p style="font-size: 1.2em; margin: 0;"><b>INVITATION TO BID (ITB)</b></p>	<p>FORMAL SEALED BID (X)      REQUEST FOR QUOTE ( )</p> <p>BIDS SHOULD BE MAILED TO:      Purchasing Department Dorchester County 201 Johnston Street Dorchester, SC 29477</p> <p>Phone: (843) 563-0140</p> <p>HAND DELIVERED AND/OR      Purchasing Department EXPRESS MAIL BIDS TO:      KFW Services Building 201 Johnston Street St. George, SC 29477</p> <p>(FAX BID NOT ACCEPTED)</p>
<p>*BIDS WILL BE RECEIVED UNTIL 4:00 P.M. ON: <b>May 18, 2017</b></p>	<p>Bid No. (No., Date, Time of Opening and State License Numbers to be shown on Envelope)</p> <p style="text-align: center; font-weight: bold; font-size: 1.1em;">BID No. 2017-3183-4520-32</p>
<p>LOCAL TIME-THEN PUBLICLY OPENED IF SEALED BID</p>	
<p><b>BID TITLE: Irongate Phase 2</b></p>	
<p><b>PREBID CONFERENCE: No</b></p>	
<p>S.G. Stephens, Jr., CPPO Purchasing Director</p>	<p>Mailing Date      FAX or E-MAIL QUESTIONS TO: Bid Module.</p>
<p>VENDOR NAME</p>	<p>REASON FOR NO BID</p>
<p>VENDOR MAILING ADDRESS</p>	<p>Amend Number(s) Received:</p>
<p>CITY-STATE-ZIP-CODE</p>	<p>S.C. TAX NO.</p>
<p>Telephone Number ( )</p>	<p>FEDERAL I.D. OR SOCIAL SECURITY NO.</p>
<p>Toll-Free Number ( )</p>	
<p>Fax Number ( )</p>	
<p>I certify that this bid is made without prior understanding, agreement, or connection with any corporation, firm or any corporation, firm, or person submitting a bid for the same materials, supplies, or equipment, and is in all respects fair and without collusion or fraud. I agree to abide by all conditions of this bid and certify that I am authorized to sign this bid for the bidder.</p>	<p style="text-align: center; border: 1px solid black; display: inline-block;">AUTHORIZED SIGNATURE (MANUAL)</p>
	<p style="text-align: center; border: 1px solid black; display: inline-block;">AUTHORIZED SIGNATURE (TYPE/TITLE)</p>
<p>Bid Security is attached (if required) in the amount of: 5% of Bid if over \$25,000.00.</p>	

IF A SUMMARY OF BIDS IS DESIRED, ENCLOSE A SELF-ADDRESSED STAMPED

BID ACCEPTANCE AND DELIVERY (Prices bid must be firm for a minimum of 90 days). In compliance with the Invitation, and subject to all conditions thereof, the above signed offers and agrees, if this bid is accepted within \_\_\_ days from date of opening, to furnish any or all items quoted on at prices as set forth after the item and to make delivery within \_\_\_ days after receipt of order with transportation cost included and prepaid. Unless otherwise stated and accepted herein, I agree to complete this proposed contract in less than sixty (60) days after issue date of purchase order.

**IMPORTANT**

IF YOU CONSIDER THESE SPECIFICATIONS AS RESTRICTIVE,  
SEE GENERAL PROVISIONS, PARAGRAPH #20, DISCREPANCIES.

\* Bids received after the time specified for opening cannot be considered and will be returned to the bidder unopened.

**BID SURETY IS REQUIRED ON BIDS OVER \$25,000.00 IN THE FORM OF A BIDDER'S BOND, CASHIER'S CHECK OR CERTIFIED CHECK IN AN AMOUNT OF 5% OF THE BID AMOUNT, PAYABLE TO THE DORCHESTER COUNTY TREASURER.**

**DORCHESTER COUNTY  
Purchasing Department  
201 Johnston Street  
St. George, SC 29477  
Ph: (843) 563-0140**

**BIDDERS SCHEDULE**

**BID NUMBER: 2017-3183-4520-32**

**DATE: April 28, 2017**

**OPENING DATE AND TIME: May 18, 2017 @ 4:00 PM E.S.T.**

**ADDRESS:**

**Dorchester County Purchasing Department  
201 Johnston Street  
St. George, SC 29477**

**PROCUREMENT:** **Provide and deliver [Insert]** under a term contract in accordance with the specifications, conditions, and provisions as applicable to this solicitation. All prices are to include all applicable shipping costs.

**QUANTITIES:** Quantities are estimates only and are given for the purpose of bidding. They do not indicate actual ordered quantities or guarantee quantities to be ordered.

## **BID SHEET AND SPECIFICATIONS**

This sheet must be returned with bid.

**Bid Name:** Irongate Phase 2 Project Sealed Bids

**Description:** Dorchester County, South Carolina invites sealed bids for the following:

This project includes installation of stormwater pipe and boxes to alleviate flooding conditions at the rear of properties on Ravenswood Court, Irongate Subdivision and extending through HOA property of Brandymill Subdivision discharging into Sawmill Branch.

- Clearing and grubbing
- Extending/regrade existing ditch
- Approximately 385 LF of 36 inch HDPE pipe and 75 LF of 42 inch pipe
- Three (3) stormwater raised lid boxes
- Grading swale
- Stabilization and riprap

**\*\*\*\* ALL QUANTITIES SHALL BE VERIFIED PRIOR TO BID\*\*\*\***

Dorchester County reserves the right to add or delete roads from this project to match available resurfacing funds.

All work shall conform to **SCDOT Standard Specifications For Highway Construction, Latest Edition.**

**BID SECURITY BOND:** Bid security shall be in an amount equal to at least five percent (5%) of the amount bid. Certified checks should be made payable to the Dorchester County Treasurer.

**PERFORMANCE AND INDEMNITY BOND:** Contractor shall provide a performance and indemnity bond in the amount totaling one hundred percent (100%) of the amount bid on the award date.

**PAYMENT BOND:** Contractor shall provide a payment bond equal to one hundred percent (100%) of the amount bid after contract is awarded.

**COMPLETION TIME:** Contractor shall state estimated completion times from contract award date.

**Bid Notice Number:**

**Total Lump Sum Bid** \$ \_\_\_\_\_

**Work to be completed within 45 days of award.**



Authorized Signature \_\_\_\_\_ Title \_\_\_\_\_

Company Name \_\_\_\_\_

Address \_\_\_\_\_

City, State, Zip \_\_\_\_\_ Phone/Fax No. \_\_\_\_\_

License No. \_\_\_\_\_ E-mail Address \_\_\_\_\_

Bid Sheet				
Irongate Phase 2				
4/20/2017				
Item	Unit	Quantity	Unit Price	Cost
Mobilize				
Demolish headwall, pipe and box	EA			
Extend/regrade ditch	LF	30		
Tree removal/clear & grub	EA			
Install 36 in HDPE pipe	LF	385		
Install 42 in HDPE pipe	LF	75		
Install 4x4 Drop Inlet	EA	2		
Install 5x5 Drop Inlet	Ea	1		
Swale grading	LF	460		
Install riprap	TN	6		
Hydroseed	SFT	4600		
TOTAL				

---

**Bidder Checklist:**

Bidder is acknowledging that the following items have been provided with the bid.

\_\_\_\_ Certificate of Familiarity  
Initial

\_\_\_\_ Acknowledgment of Amendment Number \_\_\_\_ - \_\_\_\_  
Initial

\_\_\_\_ Copy of Current License  
Initial

COMPANY: \_\_\_\_\_ AUTHORIZED SIGNATURE: \_\_\_\_\_

The attached Certificate of Familiarity must be returned with bid.
--

**DORCHESTER COUNTY**

**BID NO: 2017-3183-4520-32**

**BID TITLE: Irongate Phase 2**

**LIST OF REFERENCES**

*Please list four (4) references that your company has recently or currently provided similar products and/or services for.*

\_\_\_\_\_  
Company Name

\_\_\_\_\_  
Company Name

\_\_\_\_\_  
Representative

\_\_\_\_\_  
Representative

\_\_\_\_\_  
Address

\_\_\_\_\_  
Address

\_\_\_\_\_  
City, State, Zip Code

\_\_\_\_\_  
City, State, Zip Code

\_\_\_\_\_  
Telephone # / Fax #

\_\_\_\_\_  
Telephone # / Fax #

\_\_\_\_\_  
E-Mail Address

\_\_\_\_\_  
E-Mail Address

\_\_\_\_\_  
Company Name

\_\_\_\_\_  
Company Name

\_\_\_\_\_  
Representative

\_\_\_\_\_  
Representative

\_\_\_\_\_  
Address

\_\_\_\_\_  
Address

\_\_\_\_\_  
City, State, Zip Code

\_\_\_\_\_  
City, State, Zip Code

\_\_\_\_\_  
Telephone # / Fax #

\_\_\_\_\_  
Telephone # / Fax #

\_\_\_\_\_  
E-Mail Address

\_\_\_\_\_  
E-Mail Address

COMPANY: \_\_\_\_\_

AUTHORIZED SIGNATURE: \_\_\_\_\_

**BID NUMBER: 2017-3183-4520-32**

**DATE:**

**CERTIFICATE OF FAMILIARITY**

The undersigned, having fully familiarized themselves with the information contained within this entire solicitation and applicable amendments, submits the attached bid and other applicable information to the County, which I verify to be true and correct to the best of my knowledge. I certify that this bid is made without prior understanding, agreement, or connection with any corporation, firm or person submitting a bid for the same materials, supplies or equipment, and is in all respects, fair and without collusion or fraud. I agree to abide by all conditions of this bid and certify that I am authorized to sign this bid. I further certify that this bid is good for a period of ninety (90) days, unless otherwise stated.

\_\_\_\_\_  
Company Name as registered  
Signature with the IRS

\_\_\_\_\_  
Authorized

\_\_\_\_\_  
Correspondence Address

\_\_\_\_\_  
Printed Name

\_\_\_\_\_  
City, State, Zip

\_\_\_\_\_  
Title

\_\_\_\_\_  
Date

\_\_\_\_\_  
Telephone Number    Fax Number

\_\_\_\_\_  
Remittance Address

\_\_\_\_\_  
E-mail Address (PLEASE PRINT)

\_\_\_\_\_  
City, State, Zip

\_\_\_\_\_  
Telephone Number

\_\_\_\_\_  
Toll-Free Number if available

\_\_\_\_\_  
Federal Tax ID Number

\_\_\_\_\_  
SC Sales and Use Tax Number

PAGES 1 THROUGH 8  
TO BE RETURNED  
IN YOUR SEALED  
BID PACKAGE.  
OTHER PAGES  
SHALL REMAIN  
PART OF  
THE BID BY  
REFERENCE,  
AND IT  
**IS NOT** NECESSARY  
TO RETURN THESE.

## **DORCHESTER COUNTY STANDARD CONDITIONS/PROVISIONS**

### **CORRECTION OF ERRORS ON THIS BID FORM**

All prices and notations should be printed in ink or typewritten. Errors should be crossed out, corrections entered and initialed by the person signing the bid. Erasures or use of typewriter correction fluid may be cause for rejection. No bid shall be altered or amended after specified for opening.

### **AMENDMENTS.**

All amendments to and interpretations of this solicitation shall be in writing. The County shall not be legally bound by an amendment or interpretation that is not in writing.

### **ADDITIONAL INFORMATION.**

Bidders requiring additional information may submit their question(s) in writing to the Purchasing Department. Answers to questions received that would change and/or clarify this solicitation will be provided in writing to all firms that have received the original Invitation for Bid.

### **DISCUSSIONS/NEGOTIATIONS.**

By submission of a bid, vendor agrees that during the period following issuance of a bid and prior to final award of contract, vendor shall not discuss this procurement with any party, except members of the Purchasing Department or other parties designated in this solicitation. Vendor shall not attempt to discuss with or attempt to negotiate with the using Department any aspects of the procurement, without prior approval of the Buyer responsible for the procurement.

### **INSTRUCTIONS TO BIDDERS**

1. One clearly marked original and one copy of each bid must be submitted on the forms furnished by the Purchasing Department.
2. Bids, amendments thereto, or withdrawal requests received after the time advertised for bid opening will be void, regardless of when they were mailed.
3. Quote prices on units specified, with packing included.
4. Attach complete specifications for any permitted substitutions offered.
5. If specifications or descriptive papers are submitted with bids, enter bidder's name thereon.
6. If the article bid upon has a trade name or brand, show same in the bid with model number.
7. Sample, when required, must be submitted free of expense, unless otherwise specified in accordance with the conditions and instructions in the body of this bid notice.
8. Show delivery time required after order is received, in appropriate space provided on bid forms.
9. Bids must be submitted in a sealed envelope/container showing the bid number, opening date, title and appropriate license number(s) on the outside of the envelope/container. DORCHESTER COUNTY ASSUMES NO RESPONSIBILITY FOR UNMARKED ENVELOPES BEING CONSIDERED FOR AWARD.
10. The commodities and/or services must be furnished as described and specified, delivered f.o.b. destination freight prepaid. The term f.o.b. destination shall mean delivered, removed from crate, and placed inside of building, when applicable. County buildings do not have loading docks.
11. Bidders to visibly mark as "Confidential" each part of their bid that they consider to be proprietary information.

12. Bids concerning separate bid invitations are not to be combined on the same form or placed in the same envelope. Bids submitted in violation of this provision may be determined invalid.

## CONDITIONS

1. All bids must be submitted on the forms furnished. Number of Amendments received, if any, must be shown on page #1 of the Invitation for Bid. Altered or incomplete Bid Invitations, or use of substitute forms may render the bid non-responsive.
2. Unit prices will govern over extended prices, unless otherwise stated in notice.
3. Payment in connection with discount offered will be computed from the time of inspection/or acceptance.
4. In case of default by Contractor, the County reserves the right to purchase any or all items in default in open market, charging Contractor with any additional costs. **SHOULD EACH CHARGE BE ASSESSED, NO SUBSEQUENT BIDS OF THE DEFAULTING CONTRACTOR WILL BE CONSIDERED UNTIL THE ASSESSED CHARGE HAS BEEN SATISFIED.**
5. All materials and products offered must be guaranteed to meet the requirements of the specifications indicated and operate satisfactory on the County's existing equipment (as applicable). Prices bid must be based upon payment in thirty (30) days after delivery and acceptance.
6. Tie bids will be resolved, as outlined in the County's Procurement Ordinance.
7. The right is reserved to reject any bid in which the delivery time indicated is considered sufficient to delay the operation for which the commodity is intended.
8. Unless otherwise indicated in the bid notice, prices must be firm.
9. The successful bidder shall indemnify and save harmless Dorchester County and all County Officers, agents, and employees from all suits or claims of any character brought by reason of infringing on any patent trademark or copyright.
10. Dorchester County, its officers, agents, and employees shall be held harmless from liability from any claims, damages, and actions of any nature arising from the use of any materials furnished by the Contractor, provided that such liability is not attributable to negligence on the part of the using agency.
11. Ambiguous bids which are uncertain as to terms, delivery, quantity, or compliance with specifications may be rejected or otherwise disregarded.
12. Any contract entered into by the County or its departments, institutions, agencies, political subdivisions, or other entities resulting from this bid notice shall be subject to cancellation without penalty, at the end of any fiscal or appropriated year, unless otherwise provided by law.
13. Request for quotes must be received by the Purchasing Department by the date and time designated, but will not be publicly opened. **Formal sealed bids shall be publicly opened.**
14. All taxes on any items that the County may be required to pay must be shown separately, not included in the bid price.

## GENERAL PROVISIONS

1. **PROHIBITIONS OF GRATUITIES:** It shall be unethical for any person to offer, or give, or agree to give any County employee or former County employee, or for any County employee or former County employee to solicit, demand, accept, or agree to accept from another person, a gratuity or an offer of employment in connection with any decision, approval, disapproval, recommendation, or preparation of any part of a program requirement or purchase request, influencing the content of any specification or procurement standard, rendering of advice, investigation, auditing, or in any other advisory capacity in any proceeding or application,



request for ruling, determination, claim or controversy, or other particular matter pertaining to any program requirement or a contract or subcontract or to any solicitation or proposal therefore.

- 1.1 Kickbacks: It shall be unethical for any payment, gratuity, or offer of employment to be made by or on behalf of a subcontractor under a contract to the prime contractor, or higher tier subcontractor under a contract to the prime contractor, or higher tier subcontractor or any person associated therewith, as an inducement for the award of a subcontractor order.
2. ORDER OF PRECEDENCE: In the event of inconsistency between provisions of this solicitation, the inconsistency shall be resolved by giving precedence in the following order: (A) The Bidding Schedule, (B) General Provisions, (C) Instructions to Bidders, and Conditions, (D) Other Provisions of the Contract, whether incorporated by reference or otherwise, and (E) The Specifications.
3. COMPETITION: There are no Federal or State laws that prohibit bidders from submitting a bid lower than a price or bid given to the U.S. Government. Bidders may bid lower than U.S. Government Contract price without any liability, because the County is exempt from the provisions of the Robinson-Patman Act and other related laws.
4. TERMINATION: Subject to the Provisions below, the contract may be terminated by the Purchasing Department.
  - 4.1 Termination for Convenience: The County may, without cause, terminate this contract in whole or in part at any time for its convenience. In such instance, an adjustment shall be made to the Contractor, for the reasonable costs of the work performed through the date of termination. Termination costs do not include lost profits, consequential damages, delay damages, unabsorbed or under absorbed overhead of the Contractor or its subcontractors, and/or failure of Contractor to include termination for convenience clause into its subcontracts and material purchase orders shall not expose the County to liability for lost profits in conjunction with a termination for convenience settlement or equitable adjustment. Contractor expressly waives any damages, delay damages, or indirect costs which may arise from County's election to terminate this contract in whole or in part for its convenience.
  - 4.2 Termination for Cause: Termination by the County for cause, default, or negligence on the part of the Contractor shall be excluded from the foregoing provisions. Termination costs, if any, shall not apply. The ten (10) days advance notice requirement is waived, and the default provision in this bid shall apply. (See Bid Condition 4.)
5. EXCUSABLE DELAY: The Contractor shall not be liable for any excess costs, if the failure to perform the contract arises out of causes beyond the control and without the fault or negligence of the Contractor. Such causes may include, but are not restricted to, acts of God or of the public enemy, acts of the Government in either its sovereign or contractual capacity, fires, floods, epidemics, quarantine, restrictions, strikes, freight, embargoes, and unusually severe weather; but in every case the failure to perform must be beyond the control and without the fault or negligence of the Contractor. If the failure to perform is caused by the default of a subcontractor, and is such default arises out of causes beyond the control of both the Contractor and subcontractor, and without the fault or negligence of either of them, the

Contractor shall not be liable for any excess costs for failure to perform, unless the supplies or services to be furnished by the subcontractor were obtainable from other sources in sufficient time to permit the Contractor to meet the required delivery schedule.

6. **BID SCHEDULE**: Enter the manufacturer, brand, and catalog number bid and prices quoted for each item in the spaces provided on the Bid Schedule sheet. Additional pages may be attached, when applicable, for quantity prices. Quote prices in units of standard pack, pricing each item separately, unless indicated otherwise in bid instructions.
7. **BIDDERS QUALIFICATION**: Bidders must, upon request of the County, furnish satisfactory evidence of their ability to furnish products or services in accordance with the terms and conditions of these specifications. The Purchasing Department reserves the right to make the final determination as to the bidder's ability to provide the products or services requested herein.
8. **BIDDERS RESPONSIBILITY**: Each bidder shall fully acquaint himself with conditions relating to the scope and restrictions attending the execution of the work under the conditions of this bid. It is expected that this will sometimes require on-site observation. The failure or omission of a bidder to acquaint himself with existing conditions shall in no way relieve him of any obligation with respect to this bid or to the contract.
9. **AWARD CRITERIA**: Award will be made to the responsible and responsive bidder(s) whose bid is the most economical for the purpose intended, according to the criteria designated in the Invitation for Bid.

9.1 In addition to price, the Bid Evaluation will include the following factors (as they apply):

- 9.1.1 The quality of performance/workmanship of previous contracts, services, equipment or products; or references which attest to the specific experiences of others.
- 9.1.2 The timely completion of previous contracts or services or the timely delivery of past orders; or references that attest to the specific experiences of others.
- 9.1.3 The sufficiency of financial resources and its impact on ability of the bidder to perform the contract or provide the services.
- 9.1.4 The County reserves the right to conduct on-site inspections of any bidder's facilities prior to award. The results of said inspection will be considered by the County in determining bidder's capabilities of successfully administering to this contract.
- 9.1.5 The ability and availability of the bidder to provide both quality and timely maintenance, service, and/or parts.
- 9.1.6 The resale value, life cycle costing (which includes the cost of maintenance) and value analysis.
- 9.1.7 The availability and capability of local and regional vendor support as it affects the quantity, quality, and timeliness of the work or products required.
- 9.1.8 Delivery of a product and timely completion of a project as stated by vendor in the bid.
- 9.1.9 Substantial compliance or noncompliance with specifications set forth in the bid as determined by the County.
- 9.1.10 Product or parts inventory capability as it relates to a particular bid.
- 9.1.11 Results of product/equipment testing.

9.1.12 Warranty - Terms and Conditions.

- 9.2 Evaluation: Bids may be made for one lot only, or for as many lots as the bidder can supply. Award will be made by complete lots and may be made to one or more bidders.
- 9.3 Evaluation of Bids for Multiple Awards: In addition to other factors, bids will be evaluated on the basis of advantages to the County that might result from making more than one award (multiple awards). For the purpose of making this evaluation, administrative costs to the County for issuing and administering each contract awarded under this invitation will be considered, and individual awards will be for the items and combinations of items which result in the lowest aggregate price to the County, including such administrative costs.
- 9.4 Indefinite Delivery: At the discretion of Dorchester County, the contract may be extended for a time period not to exceed 24 months.
10. REJECTION: This solicitation does not commit Dorchester County to award a contract, to pay any costs incurred in the preparation of a bid, or to procure or contract for the articles of goods or services. The County reserves the right to waive minor informalities and irregularities, to accept or reject any or all bids received as a result of this request, or to cancel in part in or its entirety this bid, if it is in the best interest of the County to do so. In addition, the County reserves the right to reject any bid that contains prices for individual items or services that are inconsistent or unrealistic when compared to other prices in the same or other bids, if such action would be in the best interest of the County.
- 10.1 Rejection of Lowest Bid: Substantial negative findings from the Bid Evaluation as listed in paragraph 9, Award Criteria, and/or the factors as listed below, may result in the rejection of the lowest bid, if in the best interest of the County of Dorchester.
- 10.1.1 Additional purchase of repair/replacement parts for the low bid item, as opposed to an existing inventory of parts for a higher bid item.
  - 10.1.2 Greater service costs for the low bid item.
  - 10.1.3 Longer service time for the low bid item, which would cause longer down time of the item.
  - 10.1.4 Proven reliability of the higher bid item.
  - 10.1.5 Compatibility of the higher bid item with existing equipment.
11. ASSIGNMENT: The Contractor shall not sublet, assign, nor by means of a stock transfer or sale of its business, assign or transfer this contract without the written consent of the Purchasing Director.
12. CONTRACT ADMINISTRATION: Questions or problems arising after award of this contract shall be directed to the Purchasing Department.
13. AFFIRMATIVE ACTION: The successful bidder will take affirmative action in complying with all Federal and State requirements concerning fair employment and employment of the handicapped, and concerning the treatment of all employees, without regard or discrimination by reason of race, religion, sex, age, national origin, or physical handicap.
14. WAIVER: The County reserves the right to reject any or all bids, to waive any General

Provisions, Special Provisions, or minor specification deviation when considered to be in the best interest of this County.

15. RESTRICTIONS/LIMITATIONS: No purchases are to be made from this Contract of any item that is not listed, nor of any item that is currently authorized under any contract awarded prior to this Contract.
16. PURCHASES FROM OTHER SOURCES: The Purchasing Department reserves the right to bid separately any unusual requirements or large quantities of the items specified in this proposed contract.
17. QUALITY OF PRODUCT: Unless otherwise indicated in this bid, it is understood and agreed that any item offered or shipped on this bid shall be new, the latest model, and in first class condition, and when applicable all containers shall be new and suitable for storage or shipment, and that prices include standard commercial packaging.

Any deviations from the Specifications/Conditions listed herein must be clearly identified and explained with each bid.

18. ISSUANCE OF PURCHASE ORDERS: Dorchester County shall not be responsible for invoices that do not have a purchase order covering them.
19. ITEM SUBSTITUTIONS: No substitutes will be allowed on purchase orders received from agencies, without permission from the Purchasing Department.
20. DISCREPANCIES: A bidder who discovers a discrepancy or omission in the specification, or is in doubt of the interpretation of any part of the Invitation for Bid or considers that the Specification or Invitation for Bid is restrictive or discriminatory shall notify the Purchasing Director, in writing not later than ten (10) days prior to the scheduled bid opening, or at a pre-bid conference should one be scheduled. Exceptions taken do not obligate Dorchester County to change or alter specifications. Nothing will change the Invitation for Bid, unless written amendment is provided by the Purchasing Director at least three (3) working days before the Bid Opening.
21. BRAND NAMES: The name of any manufacturer, trade name, or manufacturer's or vendor's catalog or model number set forth in the specification is for the purpose of describing the minimum standard of quality, type, or performance. Such references are not intended to be restrictive. Bids will be considered for any brand that meets or exceeds the quality or performance specified.

# IRONGATE, PHASE II DRAINAGE IMPROVEMENTS



DORCHESTER COUNTY  
PUBLIC WORKS DEPARTMENT  
2120 EAST MAIN STREET, DORCHESTER, SC 29437  
843-632-0070 OR 843-663-0070  
[www.dorchestercounty.net](http://www.dorchestercounty.net)

IRONGATE, PHASE 2  
DRAINAGE IMPROVEMENTS  
LOCATED NEAR SUMMERVILLE  
DORCHESTER COUNTY, SOUTH CAROLINA

4/21/2017

DEMOLITION NOTES:  
 1. MATERIAL REMOVED FROM THE SITE SHALL BE DISPOSED IN ACCORDANCE WITH COUNTY, STATE, AND FEDERAL REGULATIONS.  
 2. DEMOLISHED CONCRETE MATERIAL TO BE USED ON SITE AS RIP RAP.

- PROPERTY LINE
- - - DRAINAGE EASEMENT
- - - DITCH
- - - FENCE
- - - EXISTING STORMWATER SYSTEM

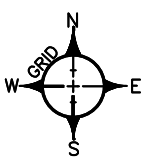
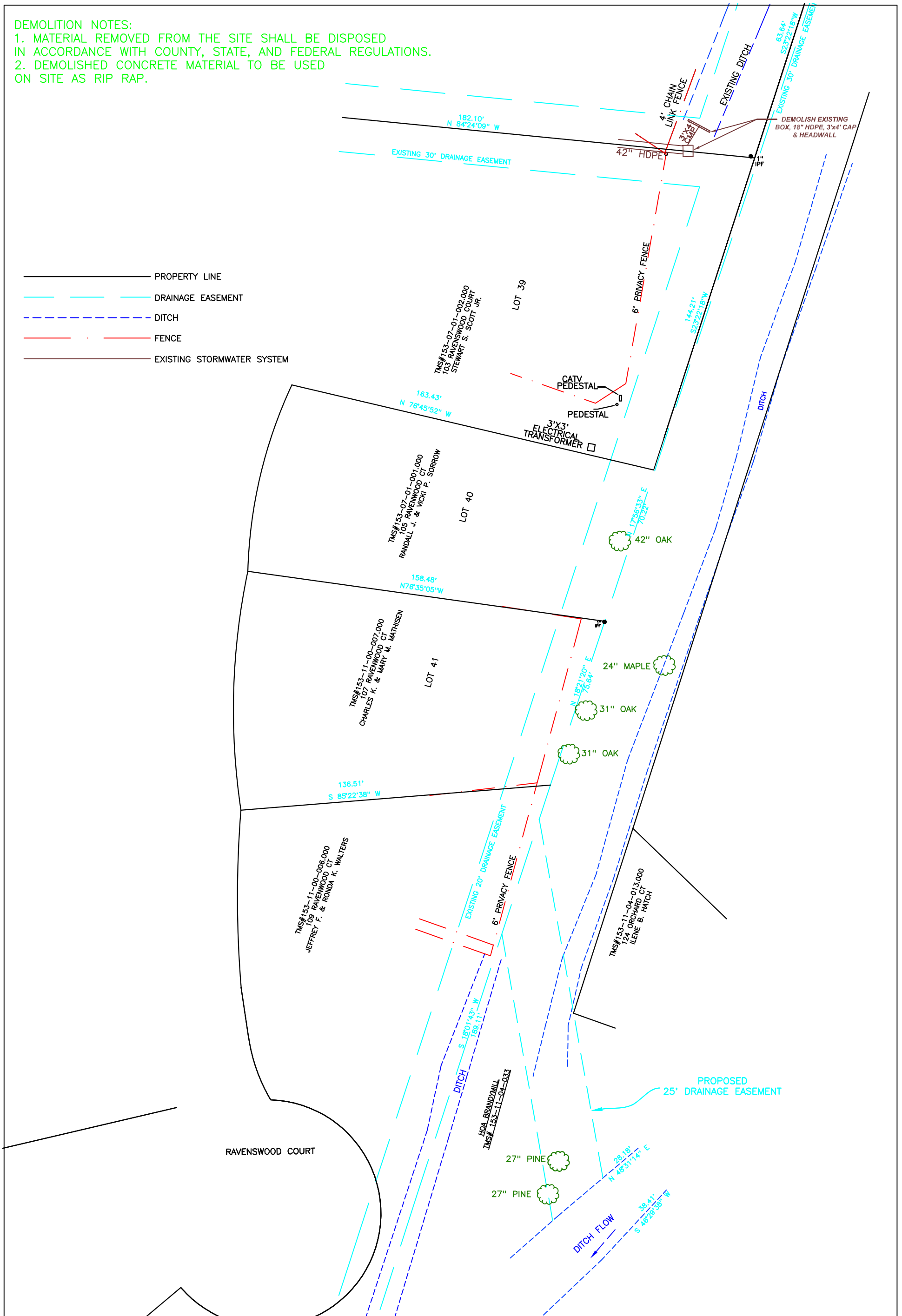

DORCHESTER COUNTY  
 PUBLIC WORKS DEPARTMENT  
 2120 EAST MAIN STREET, DORCHESTER, SC 29437  
 843-832-0070 OR 843-563-0070  
 www.dorchestercounty.net

IRONGATE, PHASE 2  
 DRAINAGE IMPROVEMENTS  
 EXISTING CONDITIONS  
 & DEMOLITIONS  
 LOCATED NEAR SUMMERVILLE  
 DORCHESTER COUNTY, SOUTH CAROLINA

4/24/2017  
 C101

- CONSTRUCTION NOTES:**
1. INSTALLATION SHALL BE IN ACCORDANCE WITH SCDOT SPECIFICATIONS AND DORCHESTER COUNTY STANDARDS
  2. CONTRACTOR IS RESPONSIBLE FOR UTILITY LOCATES AND THEIR IMPACTS TO THE PROJECT.
  3. MATERIAL REMOVED FROM THE SITE SHALL BE DISPOSED IN ACCORDANCE WITH COUNTY, STATE, AND FEDERAL REGULATIONS.
  4. LAYDOWN AREA SHALL BE APPROVED BY DORCHESTER COUNTY PRIOR TO MOBILIZATION.
  5. CONTRACTOR IS RESPONSIBLE TO IMPLEMENT EROSION AND SEDIMENT CONTROL MEASURES AS REQUIRED BY COUNTY, STATE, AND FEDERAL REGULATIONS.
  6. CONTRACTOR SHALL MAINTAIN ADEQUATE DRAINAGE AT ALL TIMES.
  7. CONTRACTOR TO VERIFY ALL QUANTITIES PRIOR TO BIDDING.
  8. BEDDING SHALL BE CLASS B, TYPE 2 DETAIL.
  9. GRADE SWALE OVER PIPE TO DRAIN TO BOX INLETS.
  10. AVOID ALL TREES 24" AND GREATER; MINIMIZE IMPACT TO ROOTS.
  11. BEARINGS AND DISTANCES FOR SWALES, DITCHES, AND CHANNELS ARE ESTIMATES. THEY ARE TO BE FIELD VERIFIED BY A LICENSED PROFESSIONAL SURVEYOR.

- PROPERTY LINE
- - - DRAINAGE EASEMENT
- - - DITCH
- - - FENCE
- STORMWATER SYSTEM

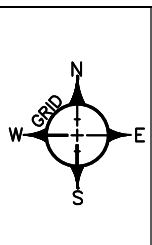
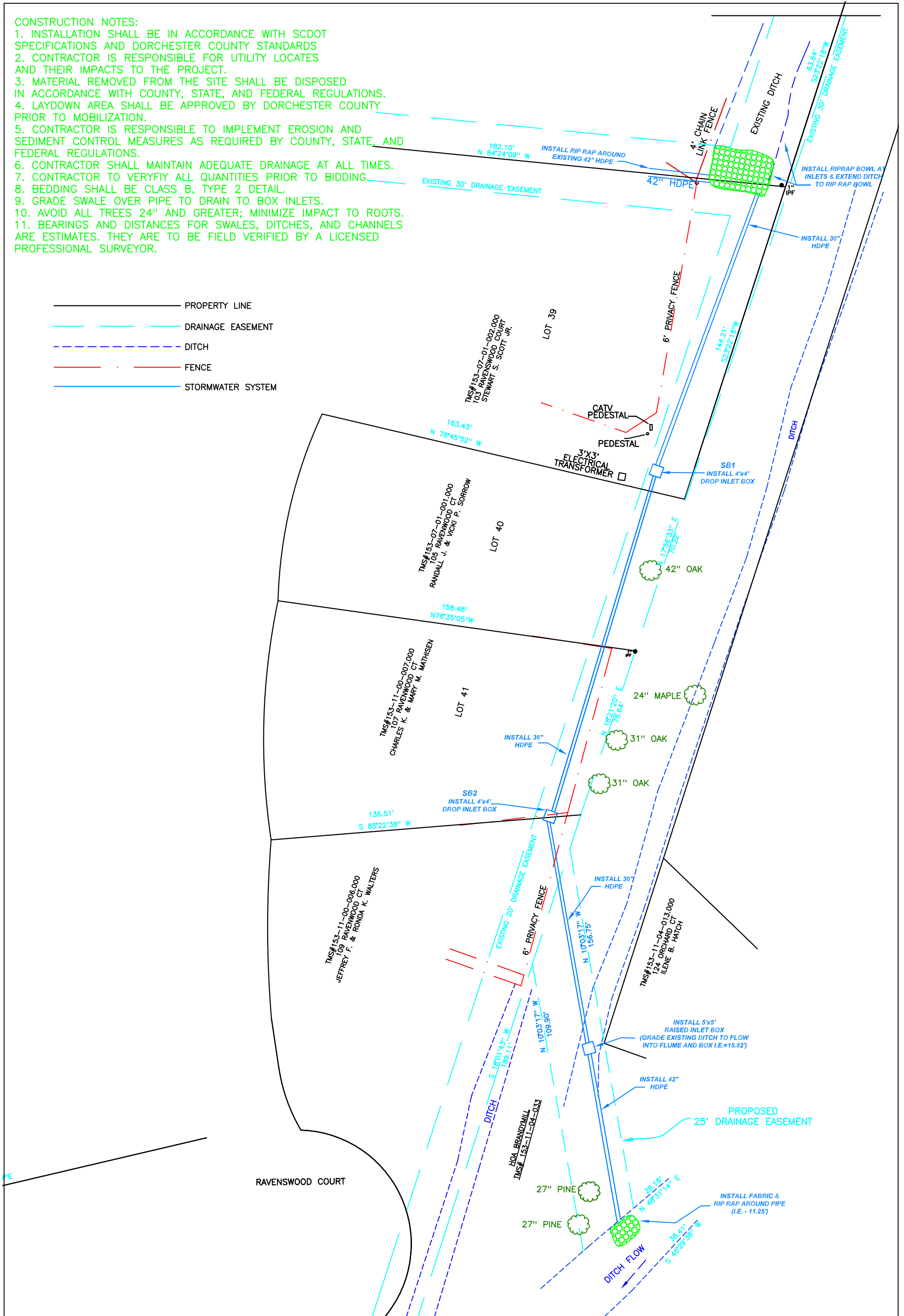

**DORCHESTER COUNTY**  
 PUBLIC WORKS DEPARTMENT  
 2120 EAST MAIN STREET, DORCHESTER, SC 29437  
 843-832-0070 OR 843-563-0070  
 www.dorchestercounty.net

**IRONGATE, PHASE 2  
 DRAINAGE IMPROVEMENTS  
 LAYOUT**  
 LOCATED NEAR SUMMERVILLE  
 DORCHESTER COUNTY, SOUTH CAROLINA

4/24/2017  
 C101

NOTE: ELEVATIONS ARE ESTIMATES AND ARE TO BE VERIFIED BY A LICENSED PROFESSIONAL SURVEYOR

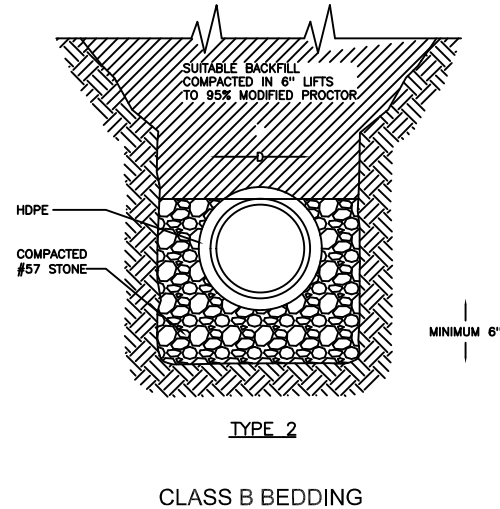
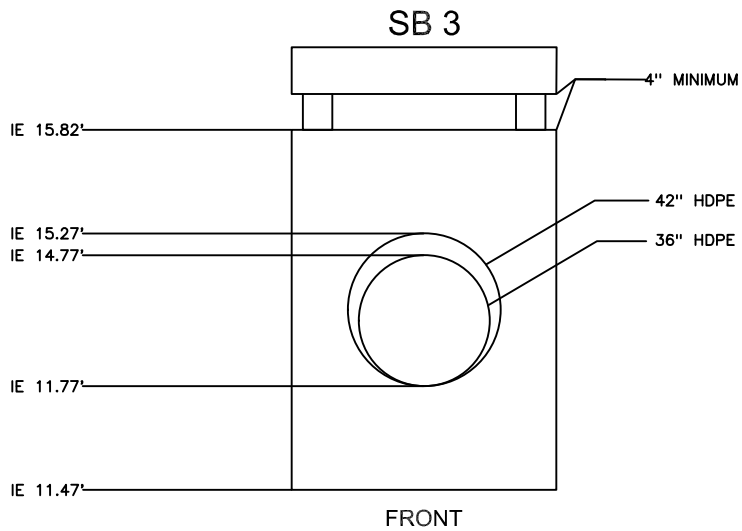
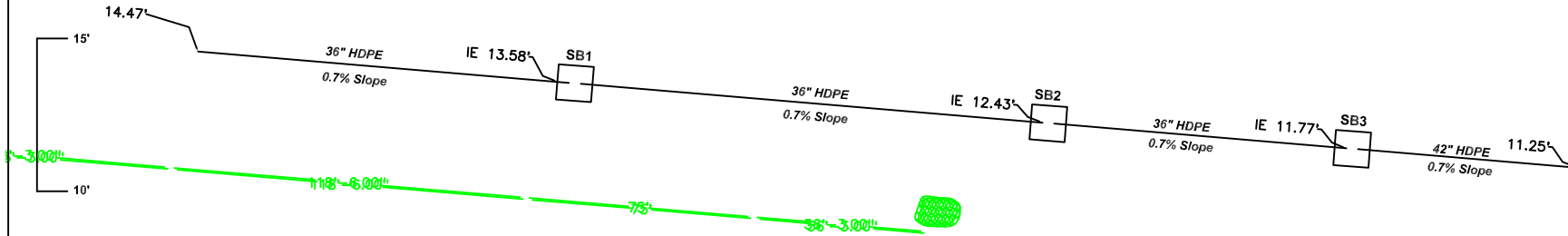

4/24/2017

BRANDY MILL  
PROPOSED 25'  
DRAINAGE IMPROVEMENT  
LOCATED NEAR SUMMERSVILLE  
DORCHESTER COUNTY, SOUTH CAROLINA

DORCHESTER COUNTY  
PUBLIC WORKS DEPARTMENT  
2120 EAST MAIN STREET, DORCHESTER, SC 29437  
843-632-0070 OR 843-963-0070  
www.dorchestercounty.net

