

SUBMITTAL COVER SHEET			DATE:	X	NEW SUBMITTAL	0430105-225	
			11/4/2016		RESUBMITTAL		
TO:	(Owner) Arlington County: 3201 S. Eads Street Arlington, VA 22202 (Architect) STV, Inc. - 2722 Merrilee Dr. Suite 350 Fairfax, VA 22031 (Engineer) Atkins N. America, Inc. - 2318 Mill Rd., Suite 1040 Alexandria, VA 22314	FROM:	W. M. SCHLOSSER CO., INC. 2400 51ST PLACE HYATTSVILLE, MD 20781				ART Bus Facility and Streetscape Improvements Contract Agreement 722-15
ATTN:	Rami Natour, Jeremy Jenkins, Patrick Standiford, George Clark						
ITEM NO.	DESCRIPTION OF ITEM SUBMITTED	Subcontractor, Manufacturer, Supplier	PROJECT SPEC SECTION	REVIEW CLASSIFICATION: A/E=ARCHITECT/ENGINEER/MIN APPROVAL I=INFORMATION ONLY		NO. OF COPIES P=PAPER E=ELECTRONIC	
	CNG Facility and Operations	Subcontractor, Manufacturer, Supplier	Spec. #	A/E		1E	
	CNG - ATS O&M Manual	(Sub)Clean Energy	0430105	A/E		1E	
Clarifications, Deviations and Comments:			I HEREBY CERTIFY THAT THE EQUIPMENT, MATERIAL AND/OR ARTICLE SHOWN/MARKED IN THIS SUBMITTAL IS IN COMPLIANCE WITH THE CONTRACT DRAWINGS AND SPECIFICATIONS, CAN BE INSTALLED IN THE ALLOCATED SPACES AND IS APPROVED FOR USE.				
This is a preliminary submittal only. Final O&M manuals will be submitted as a package per spec section 017823 - Operational and Maintenance Data. - CC, WMS							
			NAME AND SIGNATURE OF CONTRACTOR				
			Chris Chapman, WMS				
***** THIS SECTION FOR OWNER / ARCHITECT / ENGINEER USE ONLY *****							
NAME, TITLE AND SIGNATURE OF APPROVING AUTHORITY			DATE IN:	DATE OUT:			
Jeremy Jenkins - ACG NAME: _____ Construction Manager TITLE: _____ SIGNATURE: _____				11/05/16			
			ACTION TAKEN BY CONSTRUCTION MANAGER (CHECK APPLICABLE BOX):				
			<input checked="" type="checkbox"/> APPROVED (A) <input checked="" type="checkbox"/> APPROVED AS NOTED (AAN) <input type="checkbox"/> DISAPPROVED, REVISE AND RESUBMIT (RR) <input type="checkbox"/> INFORMATION ONLY/NOT REVIEWED (FIO)				

Comply with MBP submittal comments, see next page

This review is for the equipment manuals only and all other requirements under 017823 and 0430105 need to be met in order to meet the O&M requirements under your final submission. - ACG

430105-225 CNG - ATS O&M Manual

Author RJ Thompson
Date Reviewed 11/4/2016
Remark Reviewed
Submittal 430105-225
Type Submittal

Issues 2

CR-31-1 OPEN MODERATE

Although bookmarks were provided in the PDF, the links do not work.
Recommend properly bookmarking for final submission.

Required action for final submittal - Jeremy Jenkins - ACG

Assigned To Chris Chapman
Asset  CNG
Discipline Electrical
Drawing 430105-225
Created By RJ Thompson
Identified On 11/4/2016 4:46 PM

CR-31-2 OPEN MODERATE

Confirm the CNG control system has the capability to override the transfer switch if the CNG is not in operation per 430105/3.5.4. Section 5.3.1 (page 21) describes the operation of the automatic transfer but does not indicate an override is available.

Required action for final submittal - Jeremy Jenkins - ACG

Assigned To Chris Chapman
Asset  CNG
Discipline Electrical
Drawing 430105-225
Created By RJ Thompson
Identified On 11/4/2016 4:56 PM



Powering Business Worldwide

O & M Manual for ATC-900, 40-400A Open/Closed Transition Contactor Based Transfer Switch

Instruction Booklet

<i>Description</i>	<i>Page</i>
Introduction	2
Receiving, Handling, and Storage	6
Equipment Description	7
Installation and Wiring	13
Operation	19
Testing and Problem Solving	20
Adjustments	22
Maintenance	22
Renewal Parts Guide	23
ATC-900 Contactor Based ATS Quick Start Instructions	24





WARNING

READ AND UNDERSTAND THE INSTRUCTIONS CONTAINED HEREIN AFTER BEFORE ATTEMPTING TO UNPACK, ASSEMBLE, OPERATE, OR MAINTAIN THIS EQUIPMENT.

HAZARDOUS VOLTAGES ARE PRESENT INSIDE TRANSFER SWITCH ENCLOSURES THAT CAN CAUSE DEATH OR SEVERE PERSONAL INJURY. FOLLOW PROPER INSTALLATION, OPERATION, AND MAINTENANCE PROCEDURES TO AVOID THESE VOLTAGES.

TRANSFER SWITCH EQUIPMENT COVERED BY THIS INSTRUCTION BOOK IS DESIGNED AND TESTED TO OPERATE WITHIN ITS NAMEPLATE RATINGS. OPERATION OUTSIDE OF THESE RATINGS MAY CAUSE THE EQUIPMENT TO FAIL RESULTING IN DEATH, SERIOUS BODILY INJURY, AND/OR PROPERTY DAMAGE. ALL RESPONSIBLE PERSONNEL SHOULD LOCATE THE DOOR MOUNTED EQUIPMENT NAMEPLATE AND BE FAMILIAR WITH THE INFORMATION PROVIDED ON THE NAMEPLATE. A TYPICAL EQUIPMENT NAMEPLATE IS SHOWN IN FIGURE 1.

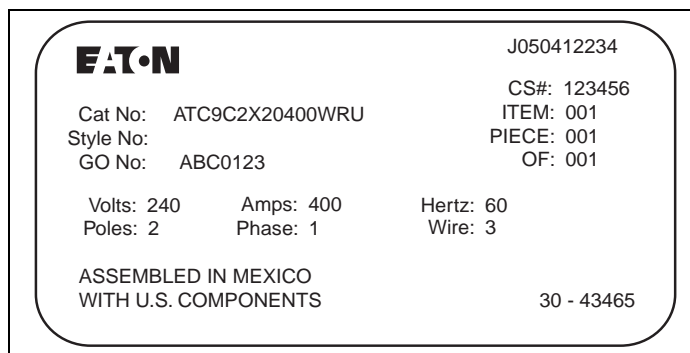

Figure 1. Typical Automatic Transfer Switch (ATS) Equipment Nameplate.

All possible contingencies that may arise during installation, operation, or maintenance, and all details and variations of this equipment do no purport to be covered by these instructions. If further information is desired by the purchaser regarding a particular installation, operation, or maintenance of particular equipment, please contact an authorized Eaton Sales Representative or the installing contractor.

Section 1: Introduction

1.1 Preliminary Comments and Safety Precautions

This technical document is intended to cover most aspects associated with the installation, application, operation, and maintenance of the Automatic Transfer Controller (ATC-900) controlled contactor based ATS with ratings from 40 through 400 amperes (A). It is provided as a guide for authorized and qualified personnel only. Please refer to the specific WARNING and CAUTION in Section 1.1.2 before proceeding. If further information is required by the purchaser regarding a particular installation, application, or maintenance activity, please contact an authorized Eaton sales representative or the installing contractor.

1.1.1 Warranty and Liability Information

No warranties, expressed or implied, including warranties of fitness for a particular purpose of merchantability, or warranties arising from course of dealing or usage of trade, are made regarding the information, recommendations and descriptions contained herein. In no event will Eaton be responsible to the purchaser or user in contract, in tort (including negligence), strict liability or otherwise for any special, indirect, incidental or consequential damage or loss whatsoever, including but not limited to damage or loss of use of equipment, plant or power system, cost of capital, loss of power, additional expenses in the use of existing power facilities, or claims against the purchaser or user by its customers resulting from the use of the information and descriptions contained herein.

1.1.2 Safety Precautions

All safety codes, safety standards, and/or regulations must be strictly observed in the installation, operation, and maintenance of this device.



WARNING

THE WARNINGS AND CAUTIONS INCLUDED AS PART OF THE PROCEDURAL STEPS IN THIS DOCUMENT ARE FOR PERSONAL SAFETY AND PROTECTION OF EQUIPMENT FROM DAMAGE. AN EXAMPLE OF A TYPICAL WARNING LABEL HEADING IS SHOWN ABOVE TO FAMILIARIZE PERSONNEL WITH THE STYLE OF PRESENTATION. THIS WILL HELP TO INSURE THAT PERSONNEL ARE ALERT TO WARNINGS, WHICH APPEAR THROUGHOUT THE DOCUMENT. IN ADDITION, WARNINGS AND CAUTIONS ARE ALL UPPER CASE AND BOLDFACE.



CAUTION

COMPLETELY READ AND UNDERSTAND THE MATERIAL PRESENTED IN THIS DOCUMENT BEFORE ATTEMPTING INSTALLATION, OPERATION, OR APPLICATION OF THE EQUIPMENT. IN ADDITION, ONLY QUALIFIED PERSONS SHOULD BE PERMITTED TO PERFORM ANY WORK ASSOCIATED WITH THIS EQUIPMENT. ANY WIRING INSTRUCTIONS PRESENTED IN THIS DOCUMENT MUST BE FOLLOWED PRECISELY. FAILURE TO DO SO COULD CAUSE PERMANENT EQUIPMENT DAMAGE.

1.2 General Information

Transfer switches are used to protect critical electrical loads against loss of power. The load's Source 1 power source is backed up by a Source 2 power source. A transfer switch is connected to both the Source 1 and Source 2 power sources and supplies the load with power from one of the two sources. In the event that power is lost from Source 1, the transfer switch transfers the load to the Source 2 power source. This transfer is automatic. Once Source 1 power is restored, the load is automatically transferred back to the Source 1 power source (Figure 2).

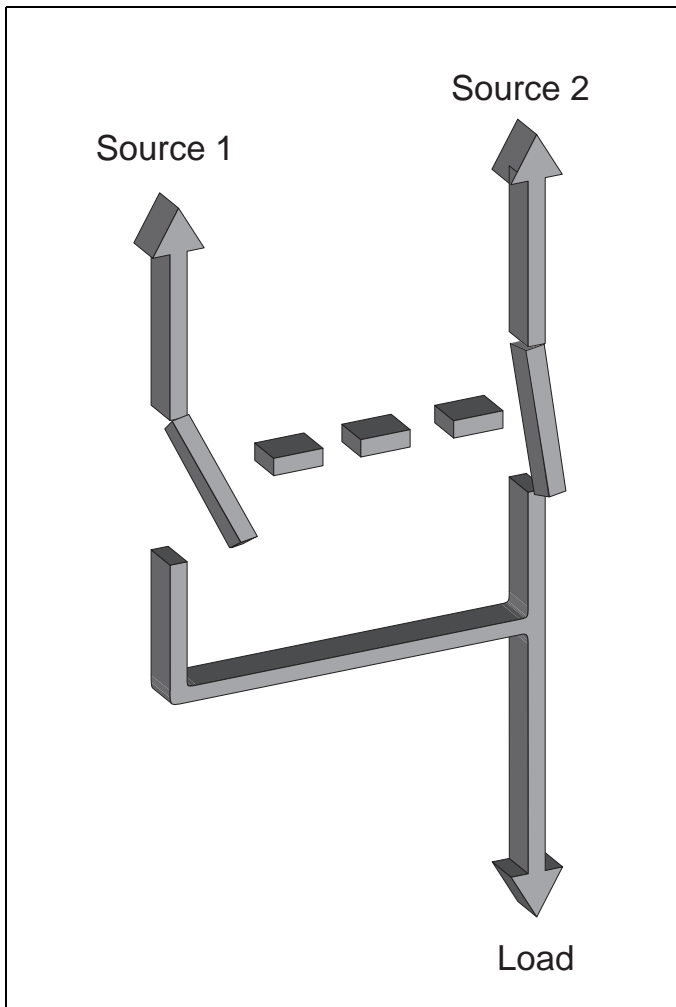

Figure 2. Typical Load Transfer Switch Schematic (Contactor Type).

In ATS equipment, the switch's intelligence system initiates the transfer when the Source 1 power fails, falls below, or rises above a preset voltage. If the Source 2 power source is a standby generator, the ATS initiates generator startup and transfers to the Source 2 power source when sufficient generator voltage is available. When Source 1 power is restored, the ATS automatically transfers back and initiates generator shutdown. In the event the Source 1 power source fails and the Source 2 power source does not appear, the ATS remains connected to the Source 1 power source until the Source 2 power source does appear. Conversely, if connected to the Source 2 power source

and the Source 2 power source fails while the Source 1 power source is still unavailable, the ATS remains connected to the Source 2 power source.

ATSs automatically perform the transfer function and include three basic elements:

1. A power contactor to connect and disconnect the load to and from either power source.
2. Solenoids to make the transfer of the main contacts from source to source.
3. Intelligence/supervisory circuits to constantly monitor the condition of the power sources and thus provide the intelligence necessary for the switch and related circuit operation.

1.2.1 Design Configuration

The Eaton contactor based ATS is a compact design that uses a power contactor to transfer essential loads from one power source to another (Figure 3 [100A]).



Figure 3. Typical Power Panel for a 100A Open Transition ATS.

The Eaton contactor based ATS was designed with easy installation and simplified maintenance in mind. Three main panels comprise the contactor based ATS design:

1. Power panel;
2. Voltage selection and transformer panel (if required); and
3. Microprocessor-based logic panel.

O&M Manual for ATC-900, 40-400A Open/Closed Transition Contactor Based Transfer Switch



Figure 4. Open Transition Contactor Based ATS (100A).

Each panel is independently mounted with interconnecting wiring terminated at the connector receptacles on the ATC-900 Controller. Door or individual panel removal is achieved without disturbing critical connections by removing the connectors from the receptacles and cutting the wire ties that secure the wires to the door.

Mounting the enclosure is simple using top and bottom mounting flanges with elongated (teardrop) mounting holes. These mounting holes, along with power panel positioning bolts and pre-tapped inserts, insure proper power panel mounting after the initial enclosure installation. Refer to Section 4 for specific mounting and modification details.

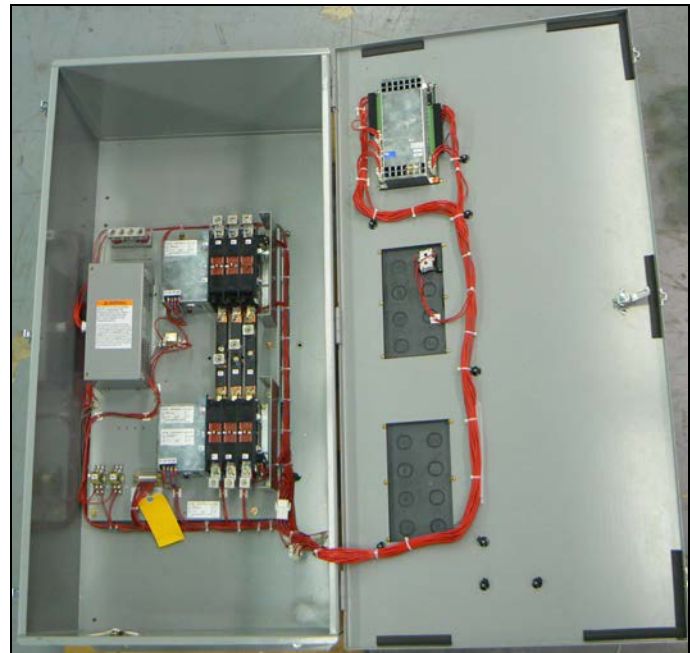

Figure 5. Closed Transition Contactor Based ATS (100A).

Table 1. Withstand Ratings.

UL 1008 WITHSTAND AND CLOSE-ON RATINGS (kA)

Switch Rating (Amps)	480 Vac		600 Vac	
	Any Breaker (Amps)	Specific Breaker (Amps)	Any Breaker (Amps)	Specific Breaker (Amps)
100A	10,000	30,000	10,000	22,000
200A	10,000	30,000	22,000	35,000
260A	30,000	50,000	-	-
320A	30,000	50,000	-	-
400A	30,000	50,000	-	-

100A (Close Transition)	10,000	30,000	10,000	22,000
200A (Close Transition)	10,000	30,000	22,000	35,000

1.3 ATS Catalog Number Identification

Transfer switch equipment catalog numbers provide a significant amount of relevant information that pertains to a particular piece of equipment. The Catalog Number Identification Table (Table 2) provides the required interpretation information. An example is offered here to initially simplify the process.

Example: Catalog Number (circled numbers correspond to position headings in Table 2).

① to ② ③ ④ ⑤ to ⑥ ⑦ ⑧ ⑨ to ⑫ ⑬ ⑭ ⑮
 AT C 9 C2 X 2 0400 W R U

The catalog number ATC9C2X20400WRU describes an ATS with a 2 pole, 2 position Power Contactor mounted on a baseplate within the enclosure. The intelligence represented by the logic panel is ATC-900 controller. The continuous current rating of this equipment is 400A and applicable at 240 Vac, 60 Hz. The transfer switch equipment is enclosed in a NEMA 3R enclosure and is listed for UL applications.

Table 2. Transfer Switch Catalog Number Explanation

POSITIONS 1 TO 2 BASIC DEVICE		POSITION 3 SWITCHING DEVICE	POSITION 4 CONTROL PANEL	POSITIONS 5 TO 6 SWITCHING DEVICE	
Automatic Transfer Switch (Open Transition) AT		Contactor C	ATC-900 Controller 9	2 Position Power Contactor C2	
Automatic Transfer Switch (Closed Transition) CT			ATC-300 3		

POSITION 7 SWITCHING DEVICE ARRANGEMENT	POSITION 8 NUMBER OF POLES	POSITIONS 9 TO 12 AMPERE RATING	POSITION 13 VOLTAGE/ FREQUENCY	POSITION 14 ENCLOSURE	POSITION 15 LISTING
Fixed Mount X	Two (2)	40A – 0040	208 Vac/60 Hz B	Type 1 S	UL/CSA Listing U
	Three (3)	80A – 0080	220 Vac/50 Hz G	Type 12 J	No Listing X
	Four (4)	100A – 0100	240 Vac/60 Hz W	Type 3R R	
		150A – 0150	380 Vac/50 Hz H	Open K	
		200A – 0200	415 Vac/50 Hz O		
		*225A – 0225	480 Vac/60 Hz X		
*260A – 0260	600 Vac/60 Hz E				
	*400A – 0400				

*For 225A to 400A, 600 Vac application, please refer to IBO1602031E.

1.4 Environmental Conditions

1.4.1 Operational Conditions

Normally, an ATS is applied indoors in an electrical equipment room. In the appropriate enclosure, it can be used for outdoor applications where the equipment is subject to falling rain, freezing temperatures, and no greater than 90% humidity (non-condensing). The ambient temperature range for operation is between -20 and 70°C (-4 to 158°F). The switch has been seismic tested and the capability exceeds the worst case Zone 4 required per both the Uniform Building Code and the California Building Code. Call the factory for the latest updates on seismic testing.

1.5 Glossary

With respect to their use within this document and as they relate to transfer switch and controller operation, the following terminology is defined.

Available

A source is defined as available when it is within its undervoltage/overvoltage/underfrequency/overfrequency (if applicable) setpoint ranges for the nominal voltage and frequency setting.

Unavailable

A source is defined as failed when it is outside of its undervoltage/ overvoltage/underfrequency/overfrequency (if applicable) setpoint ranges for the nominal voltage and frequency setting.

Normal Source

The Normal Source is defined as the source that is preferred. The Preferred Source setting allows the operator to select Source 1, Source 2 or NONE as the Preferred Source. If NONE is chosen, the Preferred Source or the Normal Source will be the source that is presently attached to the load. The default is set as being Source 1 as the Preferred and Normal Source.

Emergency Source

The Emergency Source is defined as the source that is not preferred. If NONE is chosen for the Preferred Source setting, the Emergency Source will be the source that is presently not attached to the load. Therefore, in this condition after a transfer, the Normal and Emergency Sources will switch between Source 1 and 2.

Unit Status LED

This LED blinks green indicating that the ATC-900 is operating and providing the transfer switch control function in keeping with programmed setpoints. If the LED is not lit or is on continuously, a problem may be indicated.

Connected

Connected is defined as when the input is shorted by an external contact or connection.

Unconnected

Unconnected is defined as when the input is not shorted by an external contact or connection.

Failed or Fails

A source is defined as “failed” when it is outside of the applicable voltage and frequency setpoint ranges for the nominal voltage and frequency setting for a time exceeding 0.5 seconds after the time delay emergency fail (TDEF) time delays expires.

Failsafe

Failsafe is a feature that prevents disconnection from the only available power source and also forces a transfer or re-transfer operation to the only available power source.

Transfer

Transfer is defined as a change of the load connection from the Source 1 to the Source 2 power source.

Re-Transfer

Re-transfer is defined as a change of the load connection from the Source 2 to the Source 1.

Source 1: Failed or Fails

Source 1 is defined as “failed” when it is outside of its undervoltage/overvoltage/ underfrequency/overfrequency (if applicable) setpoint ranges for the nominal voltage and frequency setting.

Source 2: Failed or Fails

Source 2 is defined as “failed” when it is outside of its undervoltage/overvoltage/ underfrequency/overfrequency (if applicable) setpoint ranges for the nominal voltage and frequency setting for a time exceeding 0.5 seconds after the Time Delay Emergency Fail (TDEF) time delay expires.

Features

The ATC-900 has many features that are available to the user. These features are standard and are available depending on the type of transfer switch used (i.e. Contactor, Power Case Switch/Breaker, or Molded Case Switch/Breaker, 2 or 3 position).

Appendix A of the ATC-900 manual has a list of all of the features including any acronyms used along with a brief description. There are many new features in the ATC-900 that are shown in the ATC-900 manual.

The ATC-900 connections are shown in Figure 16. Some connections, like engine start are wire to a separate terminal block.

There are three optional accessory items that also interface to the ATC-900, the DCT module, the I/O Module, and the Ethernet Module. See the ATC-900 manual for specific instructions on these modules. A small description of each follows:

The DCT (Direct Current-Current Transformer) Module is a current transformer interface to the ATC-900 allowing current to be metered along with voltage and frequency that is already integrated into the controller. The DCT Module simply secures to the ATC-900 back using four #8 x less than 1/2 inch screws. The ribbon cable then plugs into J14. When equipped with a DCT module, the ATC-900 serves as a multifunction power meter and provides multifunction measurement of most electrical parameters including voltage, current, power, frequency, energy, etc. The meter capabilities is specified as a 1% class energy meter. The information is displayed on the color display on the front of the ATC-900. Readings can also be monitored through the RS-485 modbus on the controller. The DCT is used to measure load current when selective load shed is enabled. The DCT Module also has a 24 Vdc input for powering the ATC-900 controller. If 120 VAC and 24 Vdc is supplied to the controller simultaneously, then the 120 Vac will be the powering supply.

The I/O Module (Figure 16B) is an extension of the ATC-900 controller's programmable inputs and outputs. Each I/O Module has four inputs and four outputs. The inputs are DC wetted (50 Volts at 10 ma) connections for various functional inputs. Up to four modules can be used with the ATC-900 giving the user up to 20 inputs or 20 outputs (including the controller's standard I/Os). Depending on the options selected with the transfer switch, some of the I/Os may be required to be fixed from the factory so that the user cannot change that particular input or output.

The Ethernet Communications Module is an accessory that operates as a communicating device in conjunction with a the ATC-900 via an Ethernet network. The Ethernet Module provides Ethernet TCP/IP.

Section 2: Receiving, Handling, and Storage**2.1 Receiving**

Every effort is made to ensure that the ATS equipment arrives at its destination undamaged and ready for installation. Packing is designed to protect internal components as well as the enclosure. Care should be exercised, however, to protect the equipment from impact at all times. Do not remove the protective packaging until the equipment is ready for installation.

When the ATS equipment reaches its destination, the customer should inspect the shipping container for any obvious signs of rough handling and/or external damage that occurred during transportation. Record any external and internal damage for reporting to the transportation carrier and Eaton, once a thorough inspection is complete. All claims should be as specific as possible and include the catalog and General Order numbers.

A shipping label affixed to the shipping container includes a variety of equipment and customer information, such as General Order Number and catalog numbers. Make certain that this information matches other shipping paper information.

Each transfer switch is packed securely with appropriate shipping materials to prevent damage during shipment. Do not remove or discard the packing material until the equipment is ready for installation.

Once the top packaging is removed from the shipment, the enclosure door can be opened. A plastic bag of documents will be found in the enclosure, usually attached to the inside of the enclosure. Important documents, such as test reports, wiring diagrams, and appropriate instruction leaflets, are enclosed within the bag and should be filed in a safe place.

2.2 Handling

As previously mentioned, ATS equipment is packaged for forklift movement. Protect the equipment from impact at all times and DO NOT double stack.

Once the equipment is at the installation location and ready to be installed, packaging material can be removed and discarded. Once the enclosure is unbolted from the wooden pallet, it can be hand moved to its installation position. Be careful not to damage the top or bottom enclosure mounting flanges. Refer to Section 4 of this manual for specific installation instructions.

2.3 Storage

Although well packaged, this equipment is not suitable for outdoor storage. The equipment warranty will not be applicable if there is evidence of outdoor storage. If the equipment is to be stored indoors for any period of time, it should be stored with its protective packaging material in place. Protect the equipment at all times from excessive moisture, construction dirt, corrosive conditions, and other contaminants.

It is strongly suggested that the package-protected equipment be stored in a climate-controlled environment with temperatures from -30 to 85 °C (-22 to 185 °F) and with a relative humidity of 80% or less. DO NOT, under any circumstance, stack other equipment on top of a transfer switch equipment enclosure, whether packaged or not.

Section 3: Equipment Description

3.1 General

The ATS consists of three basic panels:

1. The power panel;
2. The voltage selection and transformer panel (if required); and
3. The microprocessor-based logic panel.

These panels are interconnected via connector plugs and mounted in an enclosure (see Figures 6 and 7).

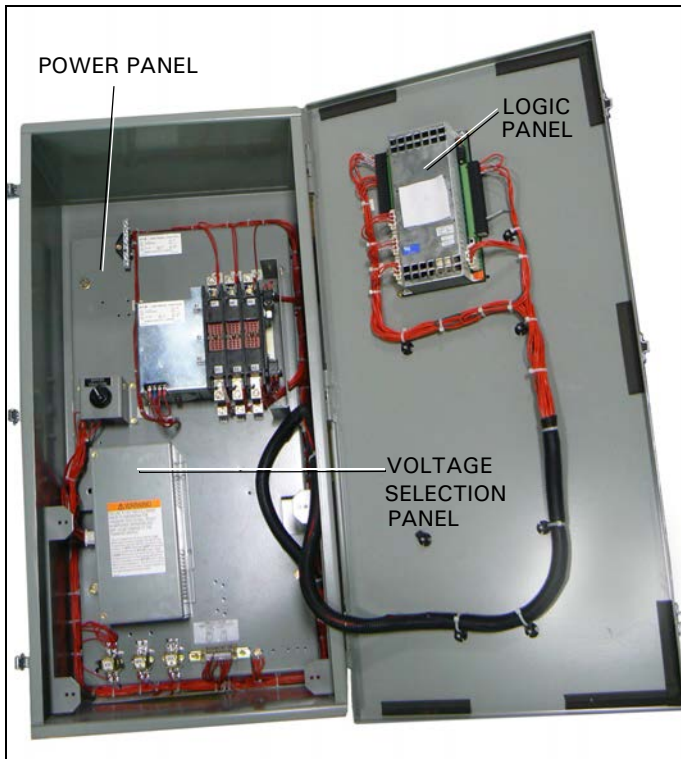

Figure 6. Three Basic Panels of the Open Transition ATS (40-400A).

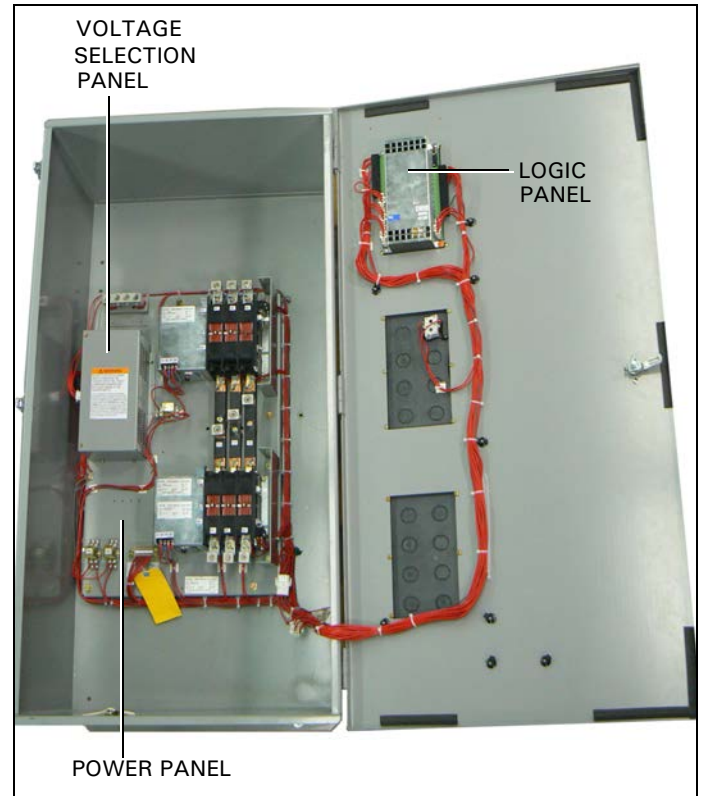

Figure 7. Three Basic Panels of the Closed Transition ATS (40-400A).

3.2 Power Panel

The power panel is used for making load, power, and neutral connections. The power contactor is mounted on a steel baseplate (Figure 8).

3.2.1 Main Contacts

This ATS incorporates a power contactor. The main contacts connect and disconnect the load to and from the different power sources. The power contactor is mechanically and electrically interlocked to prevent the two sets of main contacts from being closed simultaneously.



Figure 8. Typical Power Panel for 40-400A Open Transition ATS.



Figure 9. Standard Voltage Selection Terminals (Shown Connected to the 480 Vac Taps).

3.3 Voltage Selection

3.3.1 Standard Voltage Selection (208, 240, 480, 600 V, - 60 Hz & 220, 380, 415 V, - 50 Hz)

The standard voltage selection panel consists of multi-tap transformers, contained in a steel case mounted in the enclosure (Figure 9). The voltage is selected by simply removing the wires from the default primary taps of both transformers and installing them on the primary taps for the desired voltage. Taps are provided for 208 to 600 Vac to satisfy application voltage. The factory default position is 600 Vac.

CAUTION

WHEN CHANGING THE SELECTED VOLTAGE, THE POWER MUST BE REMOVED FROM THE ATS AND THE WIRES MUST BE MOVED ON THE TAPS OF BOTH TRANSFORMERS.

3.4 ATC-900 Logic Panel

The ATC-900 is a microprocessor-based transfer switch logic control package. The hardware and software of the controller contain the intelligence/supervisory circuits that constantly monitor the condition of the power sources. It provides the intelligence necessary for the operation of the ATS (Figure 10).



Figure 10. ATC-900 Logic Control Panel.

The ATC-900 controller has an operating temperature of -20 to 70°C (-4 to 158°F).

The controller circuit board is protected by an insulating conformal coating.

The specifications, under normal operating conditions, are as follows:

- Tolerance for voltage sensing function: $\pm 1\%$ of full scale.
- Tolerance for frequency sensing function: ± 0.3 Hz of setting.

Please see the ATC-900 controller's Instruction Booklet for new features and instructions.

3.5 Features and Glossary of Terms

A variety of standard and optional features are available for Eaton ATs. **All features or combinations of features may not be available on specific ATs.** All features and/or accessories are Underwriters Laboratories (UL) listed unless noted.

3.5.1 Operational Simplicity

From installation, to programming, to usage, the ATC-900 was designed with operational simplicity in mind. Only one style needs to be considered, regardless of input/output requirements or system voltages and frequencies. ATC-900 provides the functionality of numerous other devices combined in one package that mounts in less than 7 by 11 inches of panel space.

The user friendly front panel interface simplifies routine operation, programming, data presentation and setting adjustments. A large color display provides flexibility and ease of use. The operation of front panel membrane pushbuttons moves the ATC-900 display from function to function or step to step within menus. A single LED at the top of the faceplate provides an immediate indication as to the device's operational mode. An integrated Help Mode provides immediate user assistance in the form of English language message displays through the use of a front panel Help pushbutton.

The ATC-900 is communications ready, including Modbus 485, Ethernet (External), and USB for thumb drives (memory sticks).

3.5.2 Features and Glossary of Terms

A variety of programmable features are available to meet a wide array of application requirements. Individual features or feature combinations provide the information required to tailor switches to individual needs.

Unlike earlier controllers, the ATC-900 comes with standard features that are ready to use, with the exception of Closed Transition, In-Phase, Current metering, and Ethernet. Another advancement is that there are four (4) standard inputs and four (4) standard outputs that the operator can easily program by choosing from a wide array of predefined functions. Additional inputs and outputs can be added in groups of four (4) up to sixteen (16) for a maximum of twenty (20) in total. The inputs are DC wetted (50 Volts at 10 ma) connections for various functional inputs.

NOTICE

WITH RESPECT TO THEIR USE IN THIS DOCUMENT AND AS THEY RELATE TO AUTOMATIC TRANSFER SWITCH OPERATION, THE FOLLOWING WORDS OR PHRASES ARE DEFINED:

Options

The only item that is optional for the transfer switch is the closed transition optional feature. The switch type also dictates what can be programmed. For example, a two position contactor switch cannot have feature TDN (Time Delay Neutral), as it has no neutral position available. A motor MCS/MCCB type transfer switch with motor operator cannot have closed transition as the switching mechanism is not fast enough and will not meet the time line.

Standard Feature: In-Phase Type Operation

As shown in the feature list of Appendix A for In-Phase, there are three scenarios for In-Phase:

32C = In-Phase default to Load Voltage Decay

32D = In-Phase default to Time Delay Neutral

32F = In-Phase

There is a setpoint that allows changes to the In-Phase operation:

In-Phase = 0 Disables In-Phase (open transition)

In-Phase = 1 Enables In-Phase Defaults to Alarm
(no Transfer)

In-Phase = 2 Enables In-Phase Defaults to Open
(Time Delay Neutral for 3 position switches)

With the setpoint at "2", a two position contactor, the switch will transfer, if no synchronisation occurs, to the other source. The three position will allow the use of TDN.

Closed Transition Types Operation

Optional Feature 47C: Closed/In-phase Transition/Load Voltage Decay

Closed Transition is a feature that will temporarily parallel two live sources in a make-before-break scheme when performing a transfer. This achieves a transfer between sources with no power interruption. Both sources must be synchronized in frequency, phase, and voltage before the transfer is initiated.

In-phase transition is a feature that will allow a transfer between two live sources only when the phase difference between the two sources is near zero. This is an open transition transfer that prevents in-rush currents from exceeding normal starting currents in the case where motor loads are being transferred.

Time Delay Load Voltage Decay utilizes the load voltage measurements to sense back EMF that is generated when the transfer switch is in the neutral position. It provides a delay in transfer in either direction if an unacceptable level is sensed as established by a customer programmed level. The transfer will not take place until the back EMF decays below the acceptable programmed level. This feature has a separate setting of enabling or disabling the operation. If disabled, the transfer switch will not delay in the neutral position and will transfer between the sources as fast as possible.

Optional Feature 47D: Closed Transition Only

Closed Transition is a feature that will temporarily parallel two live sources in a make-before-break scheme when performing a transfer.

This achieves a transfer between sources with no power interruption. Both sources must be synchronized in frequency, phase, and voltage before the transfer is initiated.

If the logic is forced into a fail safe mode (i.e. loss of connected source), the logic will perform a load voltage decay open transfer.

Optional Feature 47E: Closed/In-Phase Transition/Time Delay Neutral

Closed Transition is a feature that will temporarily parallel two live sources in a make-before-break scheme when performing a transfer. This achieves a transfer between sources with no power interruption. Both sources must be synchronized in frequency phase, and voltage before the transfer is initiated.

In-phase transition is a feature that will allow a transfer between two live sources only when the phase difference between the two sources is near zero. This is an open transition transfer that prevents in-rush currents from exceeding normal starting currents in the case where motor loads are being transferred.

Time delay neutral provides a time delay in the transfer switch neutral position when both breakers are open. This delay takes place when the load is transferred in either direction to prevent excessive in-rush currents due to out of phase switching of large motor loads.

Optional Feature 47F: Closed/Load Voltage Decay

Closed Transition is a feature that will temporarily parallel two live sources in a make-before-break scheme when performing a transfer. This achieves a transfer between sources with no power interruption. Both sources must be synchronized in frequency, phase, and voltage before the transfer is initiated.

Time Delay Load Voltage Decay utilizes the load voltage measurements to sense back EMF that is generated when the transfer switch is in the neutral position. It provides a delay in transfer in either direction if an unacceptable level is sensed as established by a customer programmed level. The transfer will not take place until the back EMF decays below the acceptable programmed level. This feature has a separate setting of enabling or disabling the operation. If disabled, the transfer switch will not delay in the neutral position and will transfer between the sources as fast as possible.

Optional Feature 47G: Closed/Time Delay Neutral

Closed Transition is a feature that will temporarily parallel two live sources in a make-before-break scheme when performing a transfer This achieves a transfer between sources with no power interruption. Both sources must be synchronized in frequency, phase, and voltage before the transfer is initiated.

Time delay neutral provides a time delay in the transfer switch neutral position when both breakers are open. This delay takes place when the load is transferred in either direction to prevent excessive in-rush currents due to out of phase switching of large motor loads.

Two Options for Closed Transition

If closed transition is available on the switch, the user will either receive 47 D or all of the other options 47 C, E, F, G which can be changed by the setpoints to disable or enable the function. Screen 3 of 3 in the System Setup menu (See section 3.4.1) is where the user will set the transition types of the switch. If the switch can perform closed transition the user will set up the setpoints depending on the scenario required as shown below.

- Closed Transition only (47D) or
- Closed Transition > In-Phase > TDN
- Closed Transition > In-Phase > LVD
- Closed Transition > TDN
- Closed Transition > LVD

The user can disable closed transition and just use the following:

- In-Phase > TDN
- In-Phase > LVD

Also with Closed Transition and In-Phase disabled:

- TDN or LVD

Standard Feature 3: Time Delay Emergency to Normal (TDEN)

TDEN delays the transfer to the Normal Source to permit stabilization of the Normal power source before the transfer is made. This timer will begin the countdown from its setting value when the Normal Source becomes available. During the countdown of this timer, if the Normal Source should become unavailable, the timer will be aborted. If the Preferred Source is available and the Emergency Source fails while the TDEN timer is counting down, the TDEN timer will be bypassed.

Standard Feature 4: Time Delay for Engine Cool-Off (TDEC)

TDEC permits the generator to run under a no-load condition after a transfer from the generator source has been made. Countdown timing begins when the transfer is completed. In applications where two generators are selected, the same cool-off timer setting value is used for both.

Display

There are two displays used on the ATC-900. There is the familiar MIMIC display using LEDs (see below) and the color display using the push buttons for menu operation.

Source 1 Connected - Status LED

This LED is lit green if Source 1 is connected. This is accomplished by sensing the Source 1 breaker via the S1 closed auxiliary contact.

Source 2 Connected - Status LED

This LED is lit red if Source 2 is connected. This is accomplished by sensing the Source 2 breaker via the S2 closed auxiliary contact.

Source 1 Available - Status LED

This LED is lit amber if Source 1 meets the criteria for programmed Source 1 setpoints.

Source 2 Available - Status LED

This LED is lit amber if Source 2 meets the criteria for programmed Source 2 setpoints.

Source 1 Preferred - Status LED

This LED is lit red if Source 1 is the preferred source choice.

Source 2 Preferred - Status LED

This LED is lit red if Source 2 is the preferred source choice.

Load Energized - Status LED

This LED is lit red if the load is connected to a source that is available.

⚠ CAUTION

LOAD ENERGIZE LED IS NOT A POSITIVE INDICATION THAT VOLTAGE IS NOT PRESENT ON THE LOAD TERMINALS.

⚠ CAUTION

CHANGING THE SYSTEM NOMINAL VOLTAGE OR FREQUENCY SETPOINTS WILL CAUSE PICKUP AND DROPOUT SETPOINTS TO CHANGE AUTOMATICALLY TO NEW DEFAULT VALUES.

Optional Feature 9B: Maintenance Selector Switch (MSS)

Marked "OFF", "ON". This feature provides selector switch disconnection of control to transfer thus allowing testing of the transfer switch control logic circuitry without initiating load transfer. Positioning the MSS in the "OFF" position isolates the control circuit, permitting manual operation of the transfer switch or testing of logic circuitry without load transfer.

Optional Feature 29G: Auto/Manual Operation (Available for 3-Position ATS only)

This feature provides 2-position auto/manual selector switch marked "Auto/Manual" which permits the selection of automatic or manual operation. Once the selector switch is transferred to manual mode, manual transfer between Normal (S1), Neutral and Emergency (S2) can be achieved by operating 3-position selector switch marked "Normal-OFF-Emergency".

Optional Feature 29G: Auto/Manual Operation (Available for 2-Position ATS only)

This feature provides 2-position auto/manual selector switch marked "Auto/Manual" which permits the selection of automatic or manual operation. Once the selector switch is transferred to manual mode, manual transfer between Normal (S1) and Emergency (S2) can be achieved by operating another 2-position selector switch marked "Normal-Emergency".

Optional Feature 38B: Stainless Steel Cover for Controller

Provides an added level of security by providing a pad lockable stainless steel cover for use with standard transfer switch logic controllers and/or associated device panels. These covers function with Eaton's ATC series logic controllers and device panels. The covers are designed for NEMA 1, 3R, 4X, and 12 applications.

Optional Feature 41: Space Heater With Thermostat

This feature provides a space heater and non-adjustable thermostat. External control power is not required.

Optional Feature 41a: Space Heater With Thermostat-100 Watt

This feature provides a 100 watt (W) space heater with a non-adjustable thermostat.

Optional Feature 48D: PXG200 Gateway

This Feature provides communication by using Modbus 485 on the back of ATC-900 controller. The PXG200 Gateway serves as a communication protocol translator –taking in MODBUS RTU—and present data via Ethernet TCP/IP or Modbus TCP/IP. The data can then be accessed via the built-in web server, Power Xpert software or 3rd party building management systems. PXG200 Gateway has a limit of 32 INCOM devices. 24VDC is provided to PXG200 Gateway via ELC-PS02 power supply.

Optional Feature 48RAC: Remote Annunciator Control

This feature displays status information of a remotely located ATC-900 controller. The HMI type Remote Annunciator will serially communicate with the ATC-900 over the Modbus 485 or Ethernet using a twisted shielded pair cable. The remote annunciator is a user friendly color display that is also a touch screen. One can interface with up to eight transfer switches with one annunciator. External 120VAC power supply is required for operating ATC Remote Annunciator.

Optional Feature 49B: Sensing Isolation Transformer (Up to 600 VAC only)

This feature provides 3-phase, 4-wire for Source-1 and Source-2 sensing input on ATC controller for a high resistance grounded delta system.

Optional Feature 51D1: 50kA CVX Surge Device

This feature gives protection for surge current capacity rating 50kA, upto 480VAC by providing a low impedance surge path to ground while supporting rated voltage. It provides LED indication.

Optional Feature: 51F1:100kA CVX Surge Device

This feature gives protection for surge current capacity rating 100kA, upto 480VAC by providing a low impedance surge path to ground while supporting rated voltage. It provides LED indication.

O&M Manual for ATC-900, 40-400A Open/Closed Transition Contactor Based Transfer Switch

3.6 Enclosure

The rugged steel ATS enclosure is supplied with three door hinges, regardless of enclosure size. They ensure proper support of the door and door mounted devices (see Figures 11 and 12). The hinges have removable hinge pins to facilitate door removal. Certain procedures, such as switch mounting, are simplified with the door removed. The doors are supplied as standard with padlockable latches.

The door is used to mount a variety of lights, switches, and push-buttons, depending upon the options required for a particular ATS. All lights and switches are mounted in the plastic door-mounted panel.

The rear of the enclosure is supplied with teardrop shaped holes in the top and bottom mounting flanges to facilitate mounting. It is also supplied with two positioning bolts and various pre-tapped inserts to insure proper positioning of the power panel anytime the power panel must be repositioned to accommodate a different cable entry position. Cable entry holes are the responsibility of the customer.

ATS enclosures and all internal steel mounting plates, such as the power panel mounting plate, go through a pretreatment cleaning system prior to painting to ensure a durable finish.

The standard ATS enclosure is NEMA 1 Type for general use. However, a variety of enclosures are available to address almost any environmental circumstance (see Table 3).

Table 3. Transfer Switch Equipment Enclosures

NEMA TYPE	DESIGN	PROTECTION
Open	Indoor	
1	Indoor	Enclosed Equipment
3R	Outdoor	Rain, Ice Formation
12	Indoor	Dust, Dirt, and Non-Corrosive Liquids

3.7 Standards

Eaton ATS equipment, enclosed in any of the enclosures listed in Table 3, is listed for application by UL and ULC. In addition, Eaton ATSs are listed in File E38116 by Underwriters Laboratories, Inc. under Standard UL 1008. This standard covers requirements for automatic transfer switches intended for use in ordinary locations to provide lighting and power as follows:

- a. In emergency systems, in accordance with articles 517 and 700 in the National Electrical Code, ANSI/ NFPA 70, and the National Fire Protection Association No. 76A; and/or
- b. In standby systems, in accordance with article 702 of the National Electrical Code; and/or
- c. In legally required standby systems in accordance with article 701 of the National Electrical Code.

Eaton ATSs are available to meet NFPA 110 for emergency and standby power systems, and NFPA 99 for health care facilities when ordered with the appropriate options.

Standard UL 1008 for ATSs lists devices under the reexamination program which only require a continual physical reexamination of the components used in the product to ensure consistency with the originally submitted device. Follow-up testing is not required by UL 1008.



Figure 11. Typical Type 1 Open Transition ATS Enclosure (Door Closed).



Figure 12. Typical Type 1 Closed Transition ATS Enclosure (Door Closed).

Section 4: Installation and Wiring

4.1 General

Eaton ATs are factory wired and tested. Installation requires solidly mounting the enclosed unit and connecting power cables and auxiliary pilot circuits. Physical mounting procedures and power cable connections are covered in this section. All other required wiring or electrical connection references are covered in a separate Customer Wiring Booklet packaged with the ATS.

Locate the wiring schematic, review it, and keep it readily available for reference purposes during installation and testing. Once an ATS is properly installed and wired, it should be mechanically and electrically checked for proper installation and operation. The procedures for these initial mechanical and electrical checks are outlined in Section 6 of this instruction manual.

! WARNING

BE CERTAIN THAT THE SOLID STEEL DOOR IS PROPERLY INSTALLED BEFORE THE TRANSFER SWITCH EQUIPMENT IS PUT INTO SERVICE. THE DOOR PROVIDES PROTECTION FROM DANGEROUS VOLTAGES AT THE LINE AND LOAD TERMINALS WHEN THE EQUIPMENT IS IN OPERATION. FAILURE TO DO SO COULD RESULT IN PERSONAL INJURY OR DEATH.

4.2 Mounting Location

Choose a location that offers a flat, rigid mounting surface capable of supporting the weight of the enclosed ATS equipment. For standard ATs, avoid locations that are moist, hot, or dusty. However, Eaton offers optional enclosure designs that can be used in special environments. If there are any doubts as to a location's suitability, discuss them with your Eaton representative.

Check to make certain that there are no pipes, wires, or other mounting hazards in the immediate mounting area that could create a problem.

Carefully remove all packing material from the ATS at the mounting location. Even though an equipment inspection should have been made when the equipment was received, make another careful inspection of the enclosure and the enclosed ATS components as the packing material is removed and the enclosure readied for mounting. Be especially alert for distorted metal, loose wires, or damaged components.

4.3 Mounting Procedure

! CAUTION

SINCE THE ENCLOSED ATs MUST BE LIFTED INTO PLACE FOR MOUNTING, BE CERTAIN THAT ADEQUATE RESOURCES ARE AVAILABLE FOR LIFTING TO AVOID PERSONNEL INJURIES OR EQUIPMENT DAMAGE.

All equipment enclosures and power panels are of the same design. Only the overall physical dimensions change. Note that the enclosure is provided with four teardrop (elongated) mounting holes, two in the top mounting flange and two in the bottom.

Cable entry holes are not part of the enclosure when shipped from the factory and must be provided in the field, either before or after mounting the enclosure. Cable access may be from the top, bottom, and/or side.

! CAUTION

EXTREME CARE SHOULD BE TAKEN TO PROTECT THE TRANSFER SWITCH FROM DRILL CHIPS, FILINGS, AND OTHER CONTAMINANTS WHEN MAKING THE CABLE ENTRY HOLES. EXTREME CARE SHOULD ALSO BE TAKEN WHEN MOUNTING THE ENCLOSURE TO PREVENT COMPONENT DAMAGE OR A FUTURE MALFUNCTION.



Figure 13. Typical (40A-400A) Open Transition Contactor Based ATS Equipment (Door Open).



Figure 14. Typical (40A-400A) Closed Transition Contactor Based ATS Equipment (Door Open).

With the enclosed ATS equipment unpacked and ready for mounting, proceed with the following steps.

Step 1: The ATS enclosure door is hinge mounted with removable hinge pins. To simplify the mounting procedure and avoid damaging the door-mounted logic panel, it is strongly suggested that the door be carefully removed and put it in a safe place until mounting is complete. To remove the door, open the door and disconnect the connectors at the back of the ATC-900 logic panel. Remove the wire ties securing the harness to the inside of the door. Carefully remove the hinge pins then the door from the enclosure.

Step 2: Install the required upper and lower mounting bolt anchors and the two upper mounting bolts in the mounting surface.

Step 3: Gently lift the enclosure and guide the teardrop holes in the upper mounting flange over the upper mounting bolts. Do not completely tighten the bolts at this time.

Step 4: While still supporting the enclosure, install the two lower mounting bolts in the lower mounting flange. Again, do not completely tighten the bolts at this time. Use shims, if required, to prevent deformation of the enclosure if the mounting surface is distorted.

Step 5: Tighten all four mounting bolts after any required shimming is completed.

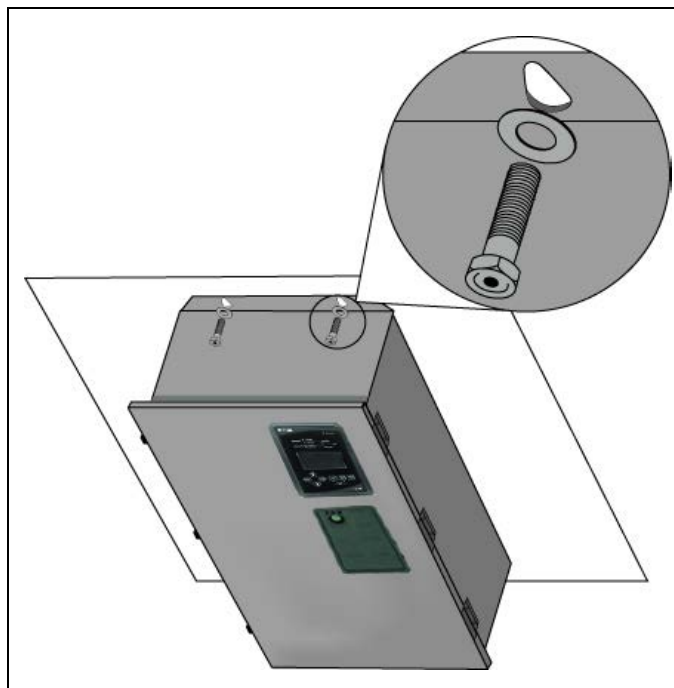

Figure 15. Typical Mounting of the ATS to a Mounting Surface.

Step 6: Double check to ensure that all packing and shipping materials have been removed.

4.4 Power Cable Connections

! WARNING

POWER CONDUCTORS MAY HAVE VOLTAGE PRESENT THAT CAN CAUSE SEVERE PERSONAL INJURY OR DEATH. DE-ENERGIZE ALL POWER OR CONTROL CIRCUIT CONDUCTORS TO BE CONNECTED TO THE ATS EQUIPMENT BEFORE BEGINNING TO WORK WITH THE CONDUCTORS AND/OR TERMINATING THEM TO THE EQUIPMENT.

! CAUTION

USE OF CABLE LUGS NOT DESIGNED FOR THE ATS MAY CAUSE HEATING PROBLEMS.



CAUTION

TO HELP PREVENT COMPONENT DAMAGE OR FUTURE MALFUNCTIONS, USE EXTREME CARE TO KEEP CONTAMINANTS OUT OF THE ATS EQUIPMENT WHEN MAKING POWER CABLE CONNECTIONS.



CAUTION

RUN THE POWER CABLE THROUGH THE GUTTER SPACE PROVIDED TO THE RIGHT OR LEFT OF POWER PANEL.

Test all power cables prior to connection to the unit to ensure that the conductors or cable insulation have not been damaged while being pulled into position.

Power cables are to be connected to solderless screw type lugs located on the ATS switching devices. Refer to the separate Customer Wiring Booklet supplied with the ATS equipment for power termination. Verify that the lugs supplied will accommodate the power cables being used. Also verify that the cables comply with local electrical codes. Standard ATS equipment, as supplied from the factory, will accommodate the wire sizes shown in Table 4.

Carefully strip the insulation from the power cables to avoid nicking or ringing of the conductor strands. Prepare the stripped conductor termination end by cleaning it with a wire brush. If aluminum conductors are used, apply an appropriate joint compound to the clean conductor surface area.



WARNING

IMPROPER POWER CABLE CONNECTIONS CAN CAUSE EXCESSIVE HEAT AND SUBSEQUENT EQUIPMENT FAILURE.

Tighten the cable lugs to the torque identified on the label affixed to the door of the unit.

4.5 Wiring



WARNING

POWER CONDUCTORS AND CONTROL WIRING MAY HAVE VOLTAGE PRESENT THAT CAN CAUSE SEVERE PERSONAL INJURY OR DEATH. DEENERGIZE ALL POWER OR CONTROL CIRCUIT CONDUCTORS BEFORE BEGINNING TO PERFORM ANY WIRING ACTIVITY TO OR WITHIN THE ATS EQUIPMENT.

Power sources, load conductors, and control wiring should be connected to locations as indicated in the Customer Wiring Booklet supplied with the ATS equipment.



CAUTION

ENSURE THE ATS VOLTAGE IS SET CORRECTLY. IT SHOULD BE THE SAME AS THE SOURCE 1 AND SOURCE 2 LINE VOLTAGES. OPERATING THE EQUIPMENT ON IMPROPER VOLTAGE CAN CAUSE EQUIPMENT DAMAGE.

Once the ATS equipment has been installed and wired, perform the initial mechanical and electrical procedures as outlined in Section 6 to verify that the equipment is installed and operating properly.

4.6 Engine Start & I/O Connections

The engine control contact connections are located on the logic panel of the ATS. Connect the engine start wires to the red terminal blocks. See the drawings for the switch. A contact closes between these terminal when an engine start signal is provided by the ATS logic. The wiring diagram provides additional engine start connection information. Use the proper wire size as listed by the generator set (Genset) manufacturer

For the I/O connections, there are some switches that the Inputs are wired to a terminal block while others are not. When they are not, the terminal blocks on the controller are simply used, see Figure 16A. The switch and listed terminal blocks are shown below.

- 1200A D frame Inputs/Gen Start to terminal blocks
- 400A and below A,B,C Gen Start to terminal blocks

NOTICE

PRIOR TO MAKING THE ENGINE START CONNECTION TO THE SWITCH, SET THE ENGINE GENERATOR CONTROLS SELECTOR SWITCH IN THE OFF POSITION TO PREVENT AN UNWANTED ENGINE START. CONTROL WIRING, SUCH AS THE ENGINE START WIRES, MUST BE RUN IN A SEPARATE CONDUIT FROM THE POWER CABLES.

Table 4. Transfer Switch Equipment Wire Sizes.

TRANSFER SWITCH AMPERE RATING	WIRE SIZE RANGES	NUMBER OF CABLES PER PHASE	TERMINAL TEMPERATURE RATING °C (°F)
100	#14-2/0	1	75 (167)
200	#6-250 KCMIL	1	75 (167)
320	#4-600 KCMIL or (2) 1/0-250 KCMIL	1 or 2 - depending on wire size used	75 (167)
400	#4-600 KCMIL or (2) 1/0-250 KCMIL	1 or 2 - depending on wire size used	75 (167)
600	#2-600 KCMIL	2	75 (167)

O&M Manual for ATC-900, 40-400A Open/Closed Transition Contactor Based Transfer Switch

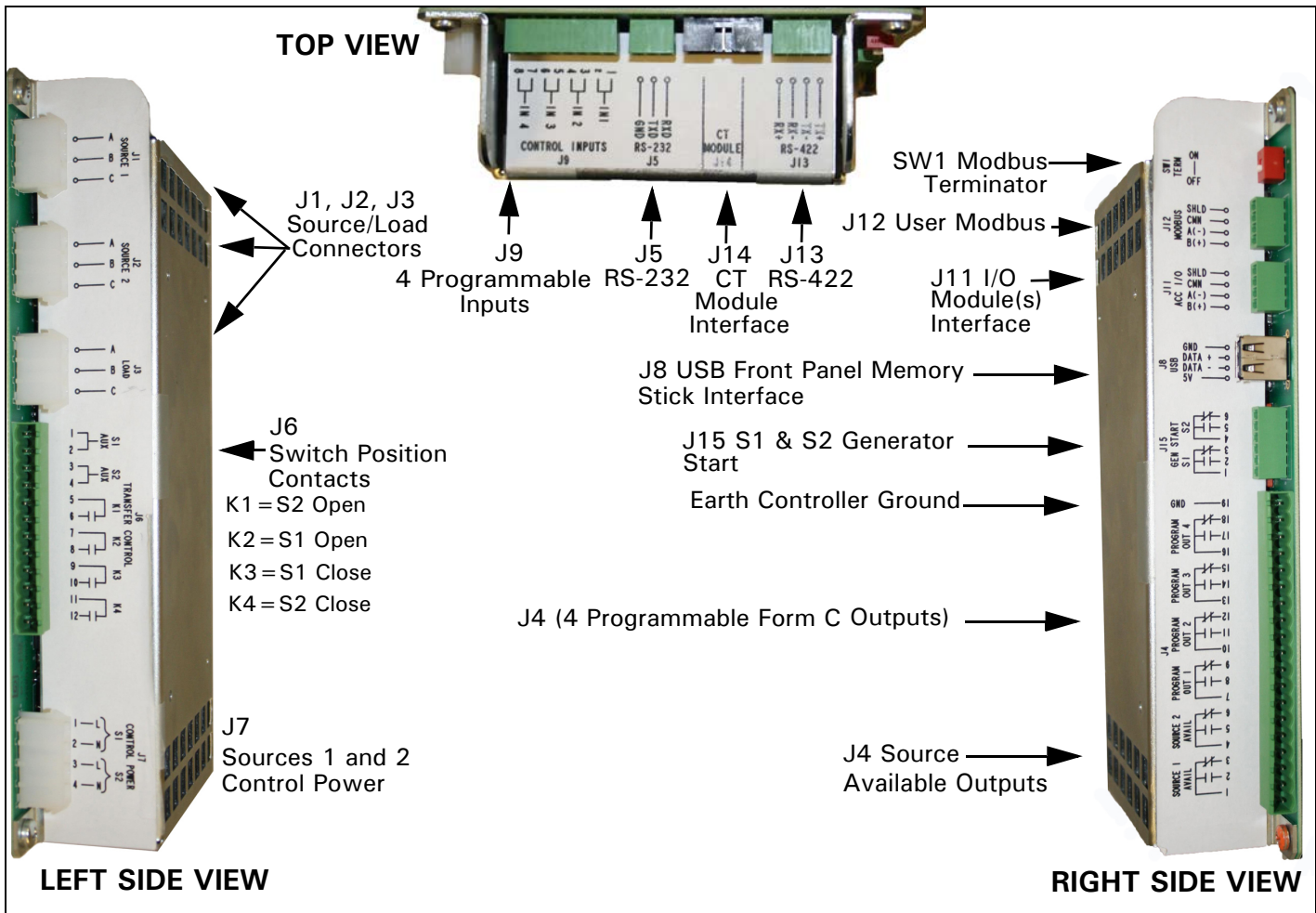

Figure 16A. ATC-900 (Top Left, and Right Side Views).



Figure 16B. I/O Module.

4.7 Voltage Selection Adjustments

Certain devices, such as the Voltage Selection Panel, sensing relays, and timers, need to be set and/or calibrated prior to placing the ATS equipment in service. Adjustments for logic devices are described in the separate instructional document dedicated to the specific logic being used. Voltage selection adjustments are described in this section.

CAUTION

BE SURE THAT THE CORRECT VOLTAGE IS SELECTED TO MATCH THE SYSTEM VOLTAGE. AN IMPROPER SELECTION AND/OR CONNECTION COULD RESULT IN EQUIPMENT DAMAGE.

4.7.1 Standard Voltage Selection Panels (208, 240, 480, 600 V, - 60 Hz & 220, 380, 415 V, - 50 Hz)

The standard voltage selection panel consists of multi-tap transformers, contained in a steel case mounted in the enclosure. To change the voltage from the factory default 600 Vac, follow the steps detailed below.

- Step 1:** Loosen the six screws securing the cover of the Voltage Selection Transformer case. Slide the cover up, then away from the case.
- Step 2:** Remove the wires from the primary taps of both transformers and installed them on the taps for the desired voltage (Figure 17B). Note that only one wire per transformer is moved since the second wire is the zero reference.
- Step 3:** Reinstall the cover and tighten the six screws.

CAUTION

WHEN CHANGING THE VOLTAGE, ONE WIRE MUST BE MOVED ON THE PRIMARY TAPS OF BOTH TRANSFORMERS.



Figure 17A. Standard Voltage Selection Panel.



Figure 17B. Standard Voltage Selection Panels.

4.8 Terminal Block Wire Installation and Removal

Proceed with the following steps and associated figures to install or remove terminal block wiring.

Step 1: Figure 18 shows two tension clamp terminal blocks. There is a large one and small one, but the operation is the same for both. A small tool, such as a screwdriver, will be pushed into the square hole next to the wire hole and a wire will be inserted into the larger circular hole on the outer edge.

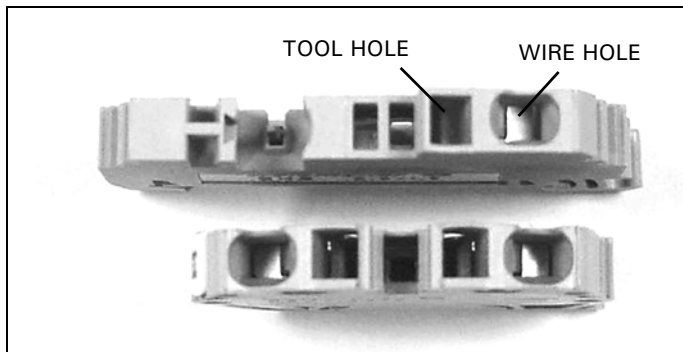

Figure 18. Tension Clamp Terminal Blocks.

Step 2: Begin by inserting a small, flathead screwdriver into the square (tool) hole with the flat surface of the screwdriver against the back wall of the hole. With a little bit of force, push the screwdriver in on a slight angle toward the center of the clamp. Be sure to slide it in until it clicks. You will then see the clamp open in the wire hole.

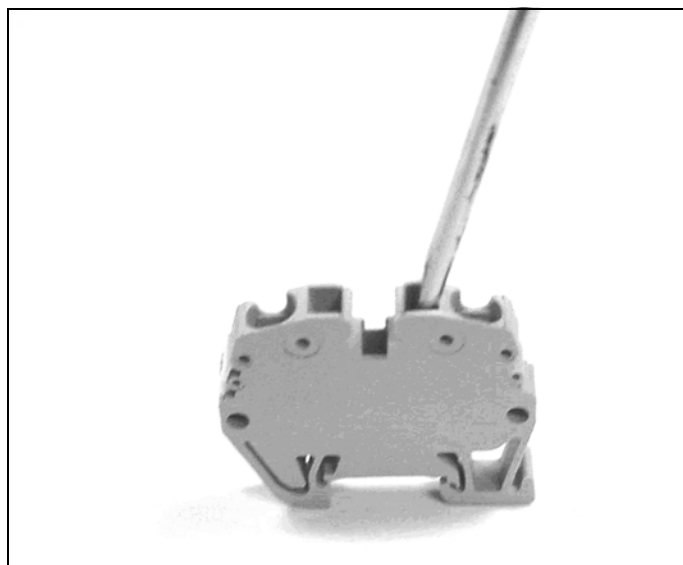

Figure 19. Screwdriver Inserted in the "Tool" Hole.

Step 3: Once the screwdriver is in place, obtain a stripped wire (strip about 1/4 in.) and insert it into the larger circular wire hole. Push the wire in until it can go no further.

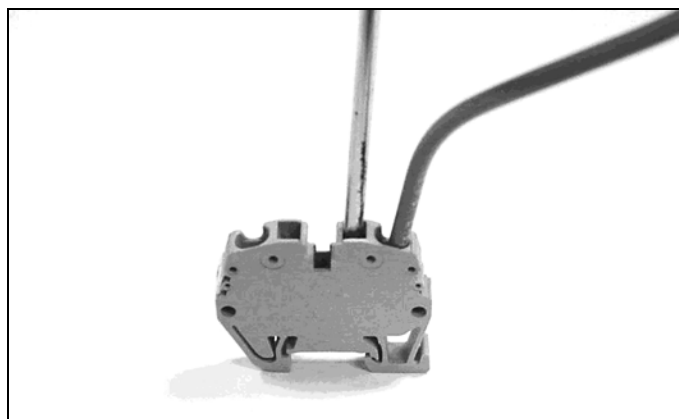

Figure 20. Wire Inserted in the "Wire" Hole.

Step 4: While holding the wire in place, pull the screwdriver out. The wire will now be held securely in the terminal block. Pull on the wire to insure that it is correctly inserted into the clamp.



Figure 21. Wire Securely Installed in the Terminal Block.

Section 5: Operation

5.1 General

An ATS provides a power contactor to connect and disconnect the load to and from the Source 1 and Source 2 power sources (Section 3.2.1).

5.2 Manual Operation

WARNING

DO NOT ATTEMPT TO MANUALLY OPERATE THE ATS WITH SOURCE 1 OR SOURCE 2 AVAILABLE.

WARNING

HIGH VOLTAGES ARE PRESENT IN AND AROUND TRANSFER SWITCH EQUIPMENT. BEFORE ATTEMPTING TO MANUALLY TRANSFER, DISCONNECT THE LINE POWER FROM THE EQUIPMENT BEING SERVICED BY OPENING AND LOCKING OUT, IF POSSIBLE, THE NEXT HIGHEST DISCONNECT DEVICE. FAILURE TO FOLLOW THIS PROCEDURE COULD CAUSE SEVERE PERSONAL INJURY AND/OR DEATH.

ALWAYS TURN THE SOURCE 1 POWER OFF AND TURN THE SOURCE 2 (IF A GENERATOR) CONTROL SELECTOR SWITCH TO THE "OFF" POSITION BEFORE ATTEMPTING A MANUAL TRANSFER.

To manually operate:

1. Disconnect all sources of power.
2. Disconnect the J7 connector from the ATC-900 controller.
3. Locate the manual lever on the left side of the contactor.
4. Locate the handle used to manually transfer the switch.
5. Attach the handle to the manual lever.
6. Rotate the lever down to go to Source 1.
7. Rotate the lever down again to go to Source 2.



Figure 22. ATS Manual Operating Handle in Use.

8. Once the manual operation is complete and automatic operation is desired, connect the sources of power.
9. Check for 120 Vac at J7-2 to J7-1 if Source 1 is available.
10. Check for 120 Vac at J7-4 to J7-3 if Source 2 is available. See the Troubleshooting Guide (Table 3, Section 7 of ATC-900 Controller Instruction Booklet I.B. ATS-C103) if values are above 130 Vac or below 110 Vac.
11. Insert the J7 connector into the controller.
12. Follow the testing procedure in Section 6 to ensure proper automatic operation.

5.3 Automatic Transfer

The operating sequence of an ATS is dictated by the switch's standard features and selected options. Operation of an ATS during Source 1 power source failure and Source 1 power source restoration will be described here with only standard options included on the switch. Additional options, as described in Section 3, can change sequences and timing, depending upon the options selected. It is strongly suggested that you become familiar with additional options selected with the particular ATS and their effect on the normal operation of an ATS.

5.3.1 Source 1 Power Source Failure

Standard Source 1 power source failure is defined as a reduction or loss of voltage. If this occurs, the sequence of operation is as follows.

1. Failure of Source 1 is detected by the controller intelligence.
2. When the controller detects a failure, the engine contacts close (after delay if programmed) and start the engine-driven generator.
3. When the Source 2 voltage reaches its operation rating, the K2 relay closes, starting the transfer operation. This operating sequence causes the contactor to open Source 1 and close on Source 2.
4. The load is now transferred to the Source 2 power source.

5.3.2 Source 1 Power Source Restoration

1. A return to the Source 1 power source begins when the voltage in all phases of a 3-phase sensing unit, or phase-to-phase in a single sensing unit, is restored to a preset value.
2. At the preset voltage, the controller will cause the K1 relay to change state. This starts the return to the Source 1 power source.
3. During this sequence, the contactor opens Source 2 and closes on Source 1.
4. Simultaneously, the engine cool-down timer initiates the shut down of the engine driven generator.
5. Transfer of the load back to the Source 1 power source is now complete.

Section 6: Testing and Problem Solving

6.1 Testing

After the ATS equipment is initially installed or during planned outages, the installation should be tested to ensure that all equipment operates properly. This attention to detail will help avoid unexpected malfunctions. Mechanical and/or electrical tests should be performed as described in this section.

The frequency of subsequent testing should be based on recommendations of the Genset manufacturer. Use the test pushbutton to check the electrical operation of the switch.

WARNING

HIGH VOLTAGES ASSOCIATED WITH OPERATIONAL TRANSFER SWITCH EQUIPMENT PRESENT A SHOCK HAZARD THAT CAN CAUSE SEVERE PERSONAL INJURY OR DEATH. USE EXTREME CAUTION TO AVOID TOUCHING ELECTRICAL CONNECTIONS WHENEVER INSPECTING OR TESTING THE EQUIPMENT.

IN ADDITION, IMPROPER OPERATION OF THE GENERATOR SET PRESENTS A HAZARD THAT CAN CAUSE SEVERE PERSONAL INJURY OR DEATH. OBSERVE ALL SAFETY PRECAUTIONS IN YOUR GENERATOR SET OPERATIONS AND INSTALLATION MANUALS.

6.1.1 Mechanical and/or Electrical Testing

NOTICE

SINCE FEATURE 4 (TIME DELAY ENGINE COOL-OFF), AS DESCRIBED IN SECTION 3, IS A STANDARD FEATURE, AN ENGINE START SIGNAL WILL BE PRESENT FOR A PERIOD OF TIME WHEN THE SWITCH IS FIRST ENERGIZED. THE PERIOD OF TIME IS EQUAL TO THE TIMER SETTING. TO AVOID STARTING THE ENGINE DURING THIS TIME PERIOD, TURN THE GENERATOR CONTROLS TO THE OFF POSITION.

Energize the ATS equipment as described in Sections 6.1.2 through 6.1.6. Insure that all safety precautions are taken and that all **WARNINGS** and **CAUTIONS** are observed.

6.1.2 No Voltage Steps

With no voltage available on either power source, proceed as follows.

- Step 1:** The generator engine start controls should be in the OFF position to prevent an undesired start.
- Step 2:** Ensure that the ATS has been set to the proper applied system voltage (See Section 4.7).
- Step 3:** Check all ATS loads to ensure that they are ready to be energized.

6.1.3 Connecting the Power Sources

- Step 1:** Close the Source 1 power source upstream protection device.
- Step 2:** Connect the engine start battery cable.
- Step 3:** With the emergency generator in the OFF position, close the Source 2 power source upstream protective device, assuming such a device used.

NOTICE

AT THIS POINT, AND PRIOR TO MAKING ANY ATTEMPT TO ENERGIZE THE ATS EQUIPMENT, THE ENGINE-DRIVEN GENERATOR SHOULD BE OPERATED. IF NECESSARY, THE VOLTAGE REGULATOR ON THE GENERATOR SHOULD BE ADJUSTED ACCORDING TO THE MANUFACTURER'S RECOMMENDATIONS. THE ATS EQUIPMENT WILL RESPOND ONLY TO THE RATED VOLTAGE AND FREQUENCY PROGRAMMED INTO THE CONTROLLER.

Step 4: Close any generator engine-start controls opened as a result of actions taken in Step 1, Section 6.1.2.

Step 5: Where required, use an accurate voltmeter to check phase-to-phase and phase-to-neutral voltages present at the transfer switch Source 1, Source 2, and/or load terminals.

6.1.4 Operational Checks

Step 1: Check to ensure that Source 1 switching device is in the CLOSED position. This should have been done in Section 6.1.3, Step 1.

Step 2: Initiate an automatic transfer operation from the Source 1 to the Source 2 power source by pressing the <Engine Test> pushbutton on the ATC-900 Controller. Set the password (factory set at 0900). After the password is entered, the test will start.

Note: The ATC-900 Logic Controller provides the capability to set the Engine Test function to:

0. No Load Engine Test;
1. Load Engine Test; or
2. Disabled.

The factory default is set to:

1. Load Engine Test
 - a. After the Time Delay Engine Starting (TDES) has timed out, the engine should start, run, and build up to normal voltage and frequency.
 - b. The transfer switch will transfer to the Source 2 power source after the Time Delay Normal to Emergency (TDNE) times out.

Step 3: Initiate an automatic transfer operation back to the Source 1 power source by pressing the <Engine Test> pushbutton on the ATC-900 Controller one time.

1. After the Time Delay Emergency to Normal timer (TDEN) has timed out, the transfer switch will transfer back to the Source 1 power source.
2. The Time Delay for Engine Cool-Off (TDEC - Feature 4) will allow the engine to run unloaded for a preset time after transfer to the Source 1 power source is completed.

6.1.5 Alternate Tests

1. Alternate operational tests may be possible depending upon the options provided with any given ATS. Refer to the schematic diagram provided with the ATS equipment, along with the specification nameplate, to determine the exact options provided.

**WARNING**

DO NOT ATTEMPT TO MANUALLY OPERATE THE ATS WITH THE SOURCE 1 POWER SOURCE CONNECTED AND AVAILABLE.

DO NOT ATTEMPT TO MANUALLY OPERATE THE ATS WITH THE SOURCE 2 POWER SOURCE CONNECTED AND AVAILABLE.

6.2 Problem Solving**WARNING**

HAZARDOUS VOLTAGES IN AND AROUND ATS EQUIPMENT DURING THE PROBLEM SOLVING PROCESS CAN CAUSE SEVERE PERSONAL INJURY AND/OR DEATH. AVOID CONTACT WITH ANY VOLTAGE SOURCE WHILE PROBLEM SOLVING.

**WARNING**

ONLY PROPERLY TRAINED PERSONNEL, FAMILIAR WITH THE ATS EQUIPMENT AND ITS ASSOCIATED EQUIPMENT, SHOULD BE PERMITTED TO PERFORM THE PROBLEM SOLVING FUNCTION. IF AN INDIVIDUAL IS NOT QUALIFIED TO PERFORM THE PROBLEM SOLVING FUNCTION, THE INDIVIDUAL SHOULD NOT ATTEMPT ANY OF THESE PROCEDURES.

A basic problem-solving effort is the first step to take prior to calling for assistance. Frequently, the effort will successfully address most problems encountered. The problem solving procedure is presented in the Troubleshooting Guide (Table 6, Section 6 of ATC-900 Controller Instruction Booklet. Remember, only qualified individuals familiar with the ATS equipment and the system in which it is applied should attempt these problem solving procedures. This includes wearing the correct PPE for the job.

If a problem persists after having completed the problem solving procedure, contact a Eaton representative for further assistance. When calling for assistance, the following is the minimum information required to properly address the need:

1. Style number of ATS, if applicable;
2. Catalog number of ATS;
3. Actual location of the ATS (type of facility, address, etc.);
4. Company name and name and position of individual representing company;
5. Basic description of the situation as it exists; and
6. Any results of the problem solving steps taken and/or readings taken.

If a problem persists after having completed the problem solving procedure, contact a Eaton representative for further assistance. When calling for assistance, the following is the minimum information required to properly address the need:

**For ATS assistance, call Eaton Care at:
877-386-2273 option 2, option 4, and then option 3**

Section 7: Adjustments

7.1 General

No Adjustments are required.

Section 8: Maintenance

8.1 Introduction



WARNING

HIGH VOLTAGES ARE PRESENT IN AND AROUND ATS EQUIPMENT. BEFORE INSPECTING OR MAINTAINING THIS EQUIPMENT, DISCONNECT THE LINE POWER FROM, THEN LOCK OUT, IF POSSIBLE, THE NEXT HIGHEST DISCONNECT DEVICE. FAILURE TO FOLLOW THIS PROCEDURE COULD CAUSE SEVERE PERSONAL INJURY AND/OR DEATH.

In general, ATS switch equipment is designed to be relatively maintenance free under normal usage. However, because of the variability of application conditions and the importance placed on dependable operation by this type of equipment, inspection and maintenance checks should be made on a regularly scheduled basis. Since equipment maintenance will consist mainly of keeping the equipment clean, the frequency of maintenance will depend to a large extent on the cleanliness of the equipment's surroundings. If a significant amount of dust or foreign matter is present, a more frequent maintenance schedule should be followed.

It is suggested that visual inspections of the equipment be made on a regular basis, not just during scheduled periods. Always be alert for an accumulation of dirt in and around the structure; loose parts; and/or hardware, cracks, and/or discoloration to insulation; and damaged or discolored components.

8.2 Procedures

A suggested maintenance procedure is outlined in Table 5.

Table 5. Periodic Maintenance Procedures.

STEP	ACTION
a. Make the ATS equipment safe for inspection and/or maintenance.	Disconnect the line power from equipment being serviced by opening the next highest disconnect device. Make certain that any accessory control power is switched off by disconnecting all control plugs.
b. Inspect the structure area for safety hazards or potential maintenance problems.	Inspect the area, especially where switching device is installed, for any safety hazards, including personnel safety and fire hazards. Exposure to certain chemical vapors can cause deterioration of electrical connections. Inspect for accumulated dirt, loose hardware, or physical damage. Examine the primary insulation for evidence of cracking or overheating. Overheating will show as discoloration, melting, or blistering of conductor insulation, or as pitting or melting of conductor surfaces due to arcing. Inspect the secondary control connections for damage and the control wiring for insulation integrity.
c. Inspect the power contactor for dust, dirt, soot, grease, moisture, or corrosion.	Remove dust, dirt, soot, grease, moisture, and corrosion contamination from the surface of the switching device using a dry soft lint-free cloth, dry soft bristle brush, and vacuum cleaner. Do not blow debris into the power contactor. If contamination is found, look for the source and fix the problem.
d. Check for material integrity, uneven wear, discoloration, or loose hardware.	Severe material cracking will require replacement and loose hardware will need to be tightened.
e. Check the terminals and connectors for looseness or signs of overheating.	Overheating will show as discoloration, melting, or blistering of the conductor insulation. Connections that do not have signs of looseness or overheating should not be disturbed.
f. Contact Inspection Procedure	Carefully remove the arc chute clips using needle nose pliers. Remove the arc chutes to inspect the contacts. Contact Eaton Care (1-877-ETN-CARE, Option-2) if the contacts have excessive wear. Reinstall the arc chutes and arc chute clips, making sure the ends of the clips are fully seated in the grooves on the barriers.
g. Exercise the power contactor if it is not often exercised while in operation. This will permit a "wiping" action by the contacts.	If the power contactor is used for frequent switching during normal operation, this step can be disregarded.
h. Return the ATS equipment to service.	Make certain all barriers are in place and doors closed. Reapply secondary and primary power.

Section 9: Renewal Parts Guide

9.1 General

Refer to Figure 23 for assistance with selecting and ordering selected ATS renewal parts. For more information, please see Renewal Parts Publication (RP01603002E).

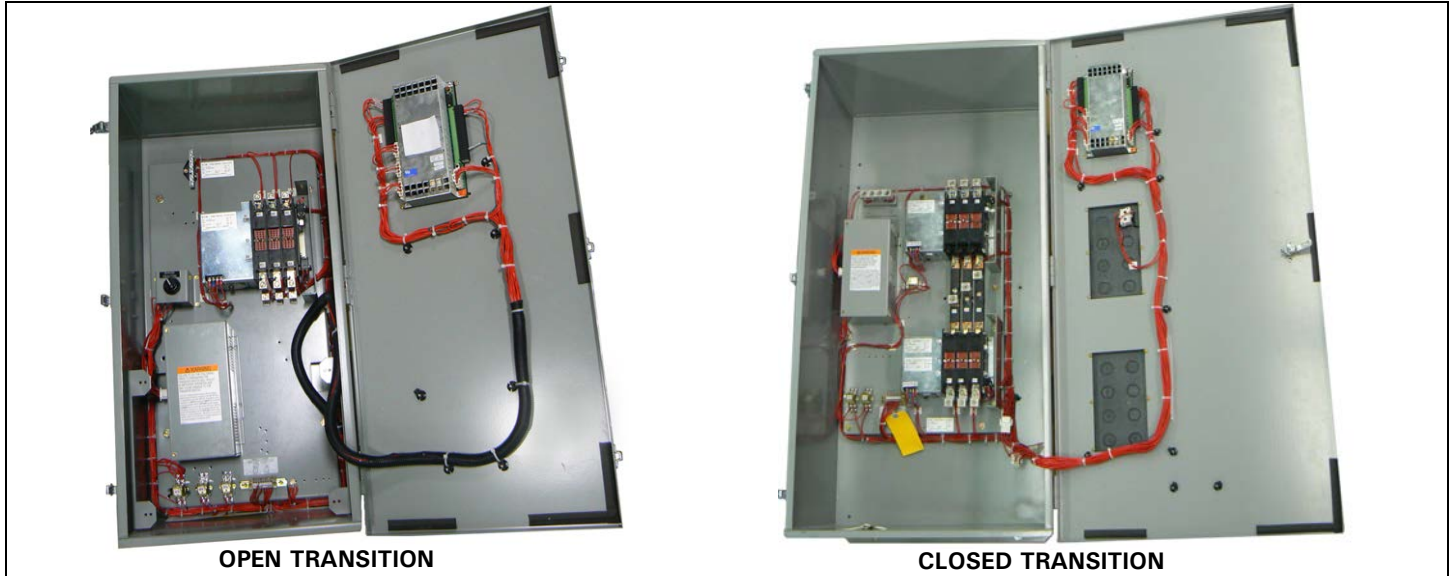

Transformer Pack	100A, 2-Pole, 3-Pole, 4-Pole - Cat# 68B2584G04 200A, 2-Pole, 3-Pole, 4-Pole - Cat# 68B2584G04 400A, 2-Pole, 3-Pole, 4-Pole - Cat# 68C8229G01
Power Panel (Open Transition)	100A (Domestic Switch), 480VAC, 2-Pole - Cat# 68C8471G14 100A (Domestic Switch), 480VAC, 3-Pole - Cat# 68C8471G15 100A (Domestic Switch), 480VAC, 4-Pole - Cat# 68C8471G16 100A (AG Switch), up to 240VAC, 2-Pole - Cat# 68C8471G04 100A (AG Switch), up to 240VAC, 3-Pole - Cat# 68C8471G05 100A (AG Switch), up to 240VAC, 4-Pole - Cat# 68C8471G06 200A (Domestic Switch), 480VAC, 2-Pole - Cat# 68C8471G11 200A (Domestic Switch), 480VAC, 3-Pole - Cat# 68C8471G12 200A (Domestic Switch), 480VAC, 4-Pole - Cat# 68C8471G13 200A (AG Switch), up to 240VAC, 2-Pole - Cat# 68C8471G01 200A (AG Switch), up to 240VAC, 3-Pole - Cat# 68C8471G02 200A (AG Switch), up to 240VAC, 4-Pole - Cat# 68C8471G03 400A (Domestic Switch), 480VAC, 2-Pole - Cat# 69C2951G03 400A (Domestic Switch), 480VAC, 3-Pole - Cat# 69C2951G01 400A (Domestic Switch), 480VAC, 4-Pole - Cat# 69C2951G02 400A (AG Switch), up to 240VAC, 2-Pole - Cat# 69C2951G13 400A (AG Switch), up to 240VAC, 3-Pole - Cat# 69C2951G11 400A (AG Switch), up to 240VAC, 4-Pole - Cat# 69C2951G12 100A (Domestic Switch), 600VAC, 2-Pole - Cat# 68C8471G11 100A (Domestic Switch), 600VAC, 3-Pole - Cat# 68C8471G12 100A (Domestic Switch), 600VAC, 4-Pole - Cat# 68C8471G13 200A (Domestic Switch), 600VAC, 2-Pole - Cat# 69C2951G03 200A (Domestic Switch), 600VAC, 3-Pole - Cat# 69C2951G01 200A (Domestic Switch), 600VAC, 4-Pole - Cat# 69C2951G02
Power Panel (Closed Transition)	100A (Domestic Switch), 480AC, 2-Pole (Source-1) - Cat# 67C5239G04 100A (Domestic Switch), 480AC, 2-Pole (Source-2) - Cat# 67C5239G05 100A (Domestic Switch), 480AC, 3-Pole (Source-1) - Cat# 67C5239G06 100A (Domestic Switch), 480AC, 3-Pole (Source-2) - Cat# 67C5239G07 100A (Domestic Switch), 480AC, 4-Pole (Source-1) - Cat# 67C5239G08 100A (Domestic Switch), 480AC, 4-Pole (Source-2) - Cat# 67C5239G09

Power Panel (Closed Transition) Cont.	200A (Domestic Switch), 480AC, 2-Pole (Source-1) - Cat# 67C5240G07 200A (Domestic Switch), 480AC, 2-Pole (Source-2) - Cat# 67C5240G08 200A (Domestic Switch), 480AC, 3-Pole (Source-1) - Cat# 67C5240G09 200A (Domestic Switch), 480AC, 3-Pole (Source-2) - Cat# 67C5240G10 200A (Domestic Switch), 480AC, 4-Pole (Source-1) - Cat# 67C5240G11 200A (Domestic Switch), 480AC, 4-Pole (Source-2) - Cat# 67C5240G12 400A (Domestic Switch), 480AC, 2-Pole (Source-1) - Cat# 67C5040G07 400A (Domestic Switch), 480AC, 2-Pole (Source-2) - Cat# 67C5040G08 400A (Domestic Switch), 480AC, 3-Pole (Source-1) - Cat# 67C5040G09 400A (Domestic Switch), 480AC, 3-Pole (Source-2) - Cat# 67C5040G10 400A (Domestic Switch), 480AC, 4-Pole (Source-1) - Cat# 67C5040G11 400A (Domestic Switch), 480AC, 4-Pole (Source-2) - Cat# 67C5040G12 100A (Domestic Switch), 600AC, 2-Pole (Source-1) - Cat# 67C5240G07 100A (Domestic Switch), 600AC, 2-Pole (Source-2) - Cat# 67C5240G08 100A (Domestic Switch), 600AC, 3-Pole (Source-1) - Cat# 67C5240G09 100A (Domestic Switch), 600AC, 3-Pole (Source-2) - Cat# 67C5240G10 100A (Domestic Switch), 600AC, 4-Pole (Source-1) - Cat# 67C5240G11 100A (Domestic Switch), 600AC, 4-Pole (Source-2) - Cat# 67C5240G12 200A (Domestic Switch), 600AC, 2-Pole (Source-1) - Cat# 67C5040G07 200A (Domestic Switch), 600AC, 2-Pole (Source-2) - Cat# 67C5040G08 200A (Domestic Switch), 600AC, 3-Pole (Source-1) - Cat# 67C5040G09 200A (Domestic Switch), 600AC, 3-Pole (Source-2) - Cat# 67C5040G10 200A (Domestic Switch), 600AC, 4-Pole (Source-1) - Cat# 67C5040G11 200A (Domestic Switch), 600AC, 4-Pole (Source-2) - Cat# 67C5040G12
Wiring Harness (Open Transition)	Call Factory or look at tag on harness for part number
Wiring Harness (Closed Transition)	Call Factory or look at tag on harness for part number
100W Space Heater	AG Switch, up to 240VAC - Cat# 8160A41G55 Domestic Switch, up to 600VAC - Cat# 8160A41G54

Figure 23. Typical ATC-900 Controlled Contactor Based ATS (Open Transition / Closed Transition).

Section 10: ATC-900 Controlled ATS Quick Start Instructions

! WARNING

THESE QUICK START INSTRUCTIONS ARE NOT A COMPLETE SOURCE OF INFORMATION ON THE ATC-900 CONTROLLED ATS EQUIPMENT. INSTALLATION SHOULD NOT BE STARTED UNTIL THE ENTIRE INSTRUCTION BOOK HAS BEEN REVIEWED AND UNDERSTOOD. FAILURE TO FOLLOW THE FULL INSTRUCTIONS CAN RESULT IN DEATH, SEVERE PERSONAL INJURY, OR PROPERTY DAMAGE.

! WARNING

THESE QUICK START INSTRUCTIONS ARE PROVIDED FOR USE ONLY BY TECHNICIANS HIGHLY FAMILIAR AND EXPERIENCED WITH ATC-900 CONTROLLED ATS EQUIPMENT INSTALLATION, SET UP, AND TESTING. IT IS STRONGLY SUGGESTED THAT THE FULL INSTRUCTIONS BE FOLLOWED FOR ALL INSTALLATIONS, SET UP, AND TESTING.

Step 1: Mount the ATS on a flat rigid surface (Figure 24). Shim if necessary.

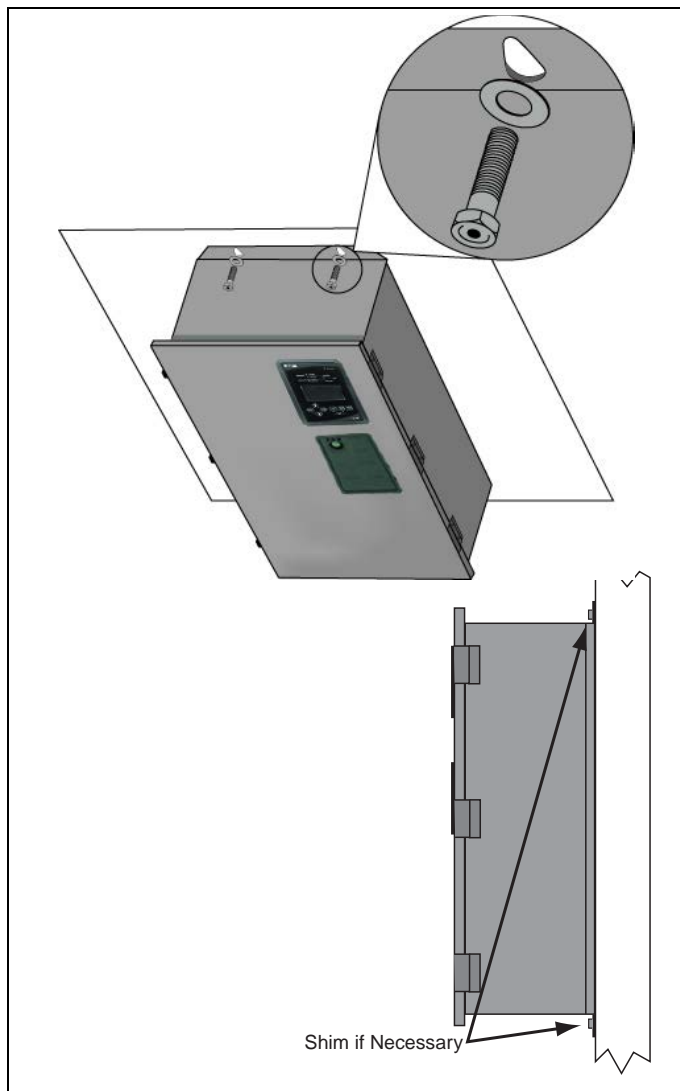

Figure 24. Mounting Details.

Step 2: Install the power cables. Cables must be sized and installed per National Electrical Code, refer to NFPA70. The cables must be sized within the specified cable size range on the side of the cable connectors.

Connect the cables and torque to the correct value indicated on the label on the door in the following order:

1. Load Cables* (T1, T2, T3);
2. Source 1 or Utility Supply (N1, N2, N3); and
3. Source 2 or Generator Supply (E1, E2, E3).

For 4 pole transfer switches, connect the load cables (TN), Source 1 or utility supply (NN), and Source 2 or generator supply (EN). Refer to Figures 25 and 26 for the location of all parts discussed in this document.

*Load cables MUST be connected and torqued BEFORE installing the SUPPLY cables (see Figures 25 and 26).

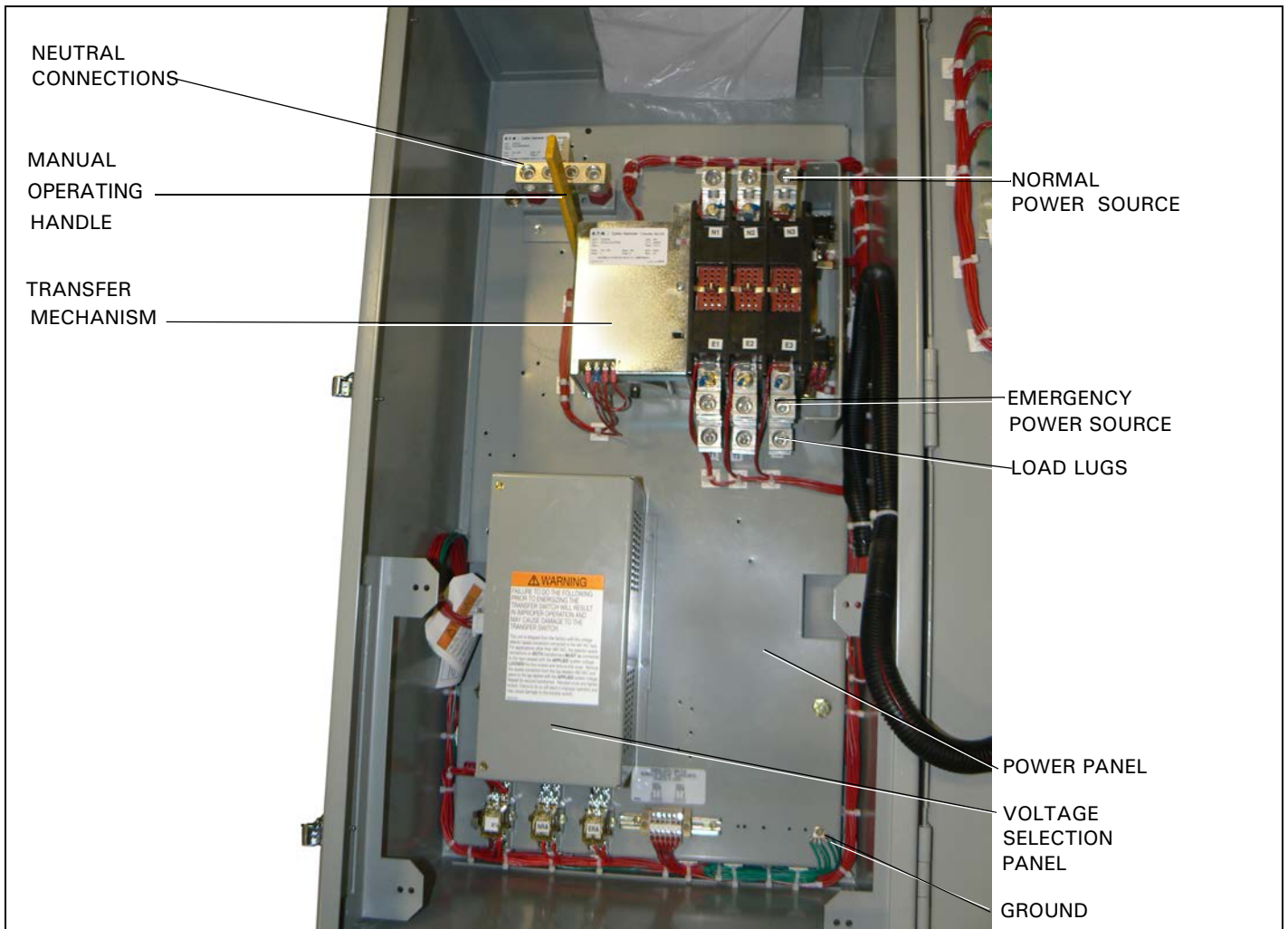

Figure 25. 100A, 3-Pole, ATS Interior Components (Open Transition).

O&M Manual for ATC-900, 40-400A Open/Closed Transition Contactor Based Transfer Switch

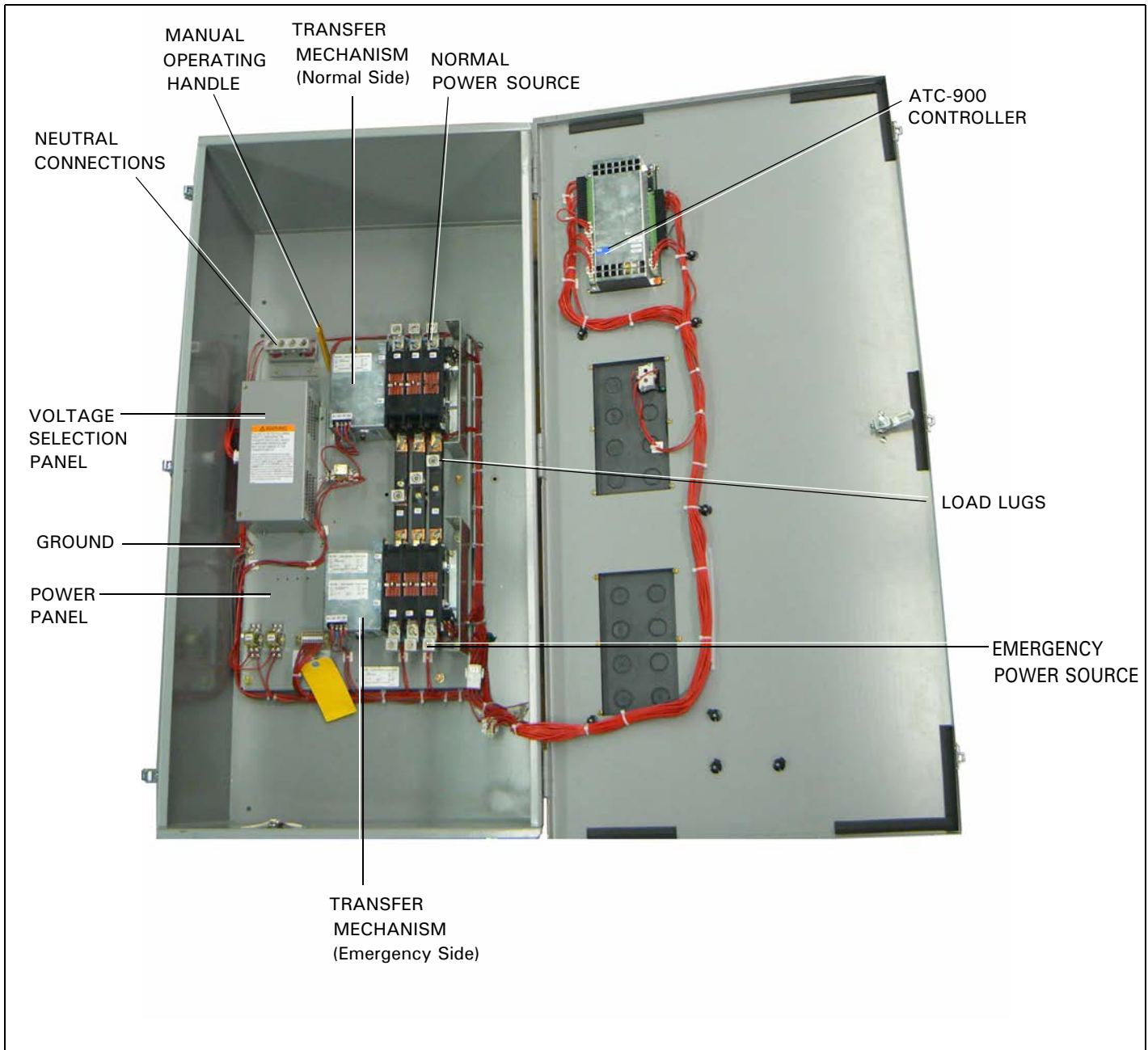

Figure 26. 100A, 3-Pole, ATS Interior Components (Closed Transition).

- Step 3:** Turn the generator OFF at the generator control panel. This will prevent unexpected activation of the generator.
- Step 4:** Connect the Engine Generator Start wires to the red terminal blocks. See section 4.6 for I/O connections (and the ATC-900 instruction booklet) if required. This contact is CLOSED whenever the engine generator is needed, and should be connected to a generator controller. **NEVER** connect directly to a starter solenoid or ignition system. See the Genset manufacturer instruction leaflet for recommended wire sizes and location procedures.
- Step 5:** Apply Utility (Source 1) power. If the switch is properly applied for the system voltage ordered, the display should work and the Source 1 Available amber LED should light on the controller. Using a voltmeter, check for proper system voltage on Source 1 and load terminals. Check all phases on a 3-phase switch. Voltage measurements should be taken phase to phase and phase to neutral.
- Step 6:** To view the setpoints, see the ATC-900 instruction manual.

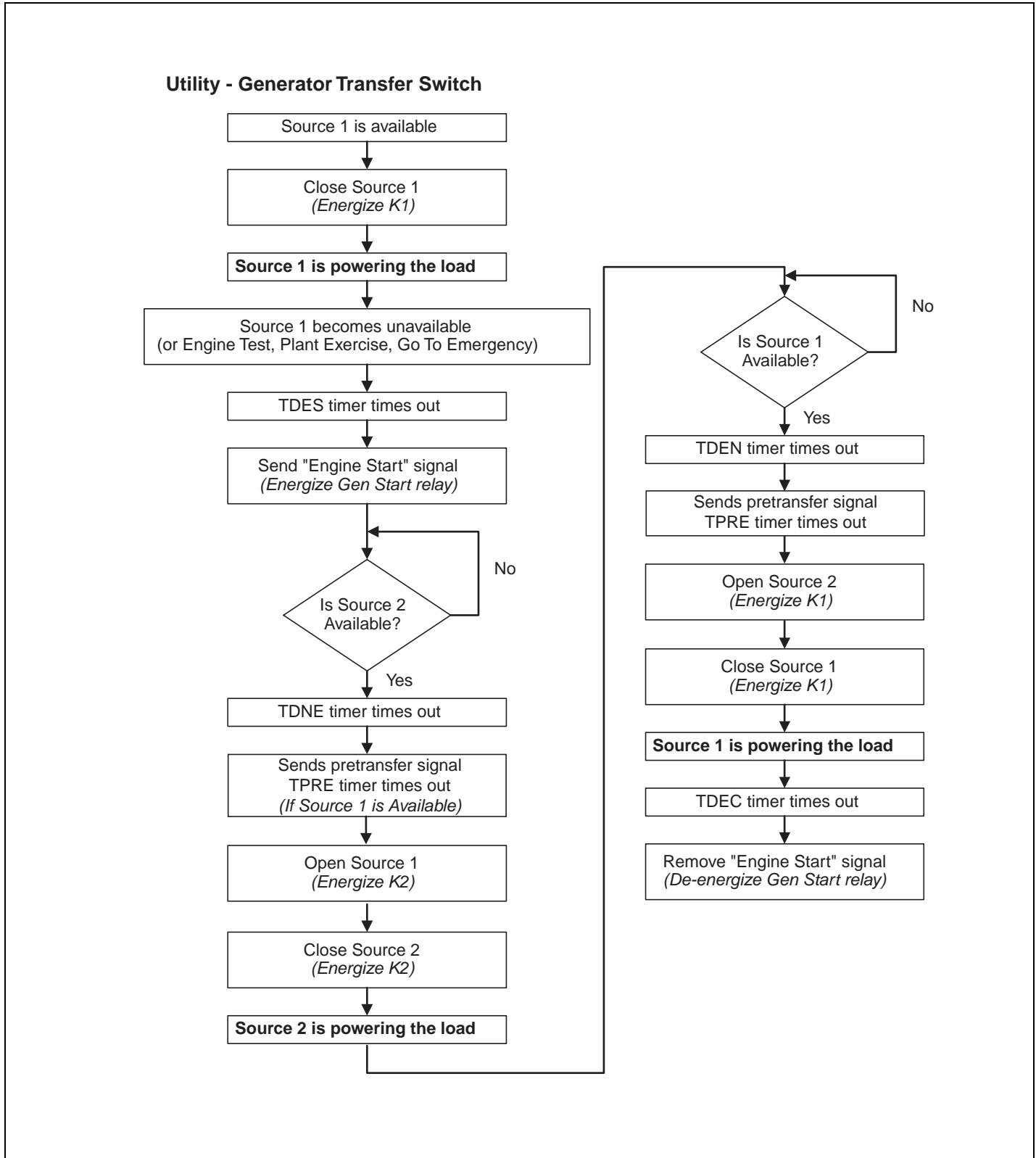

Figure 27. Utility - Generator Transfer Switch.

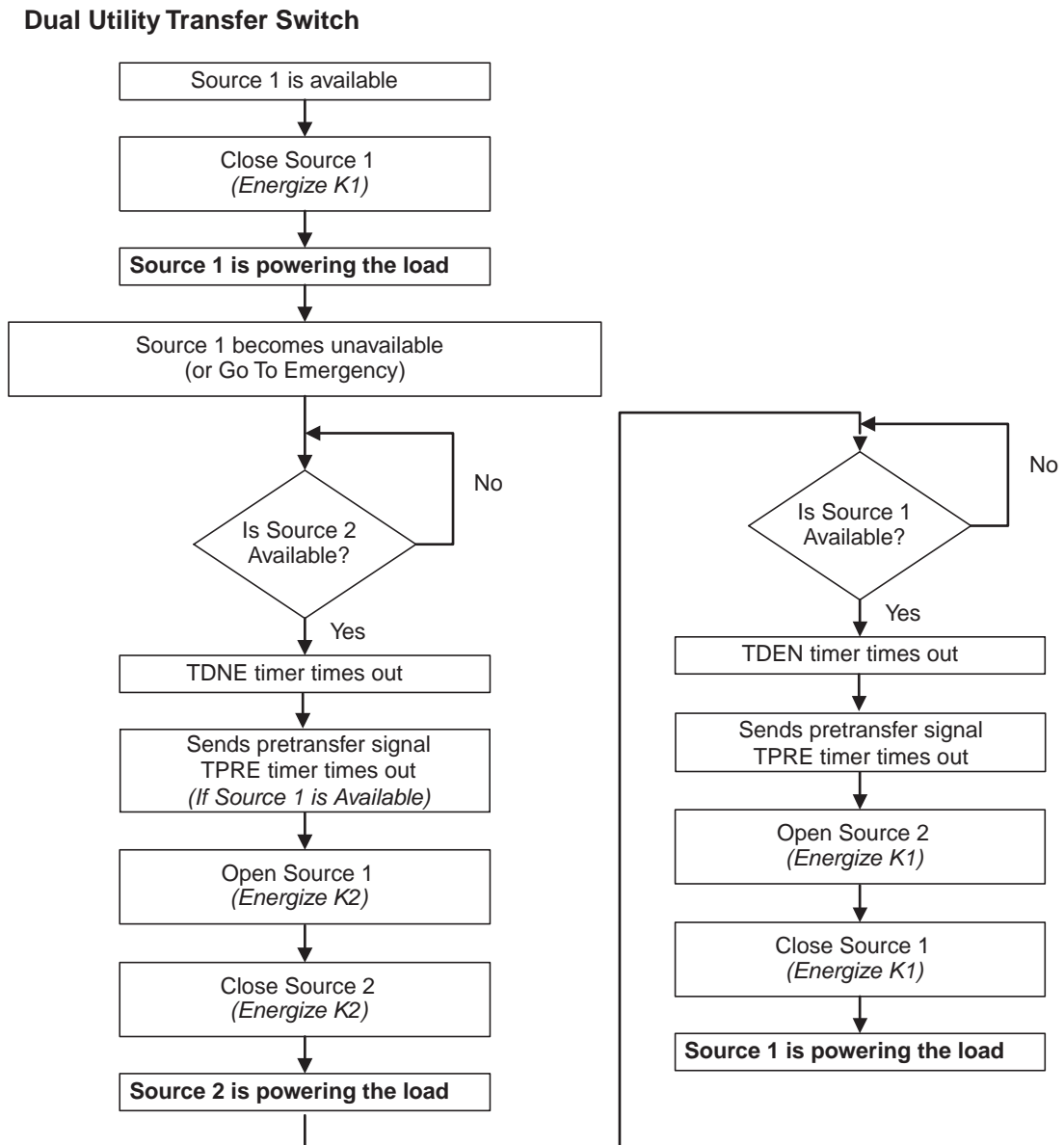

Figure 28. Dual Utility Transfer Switch.

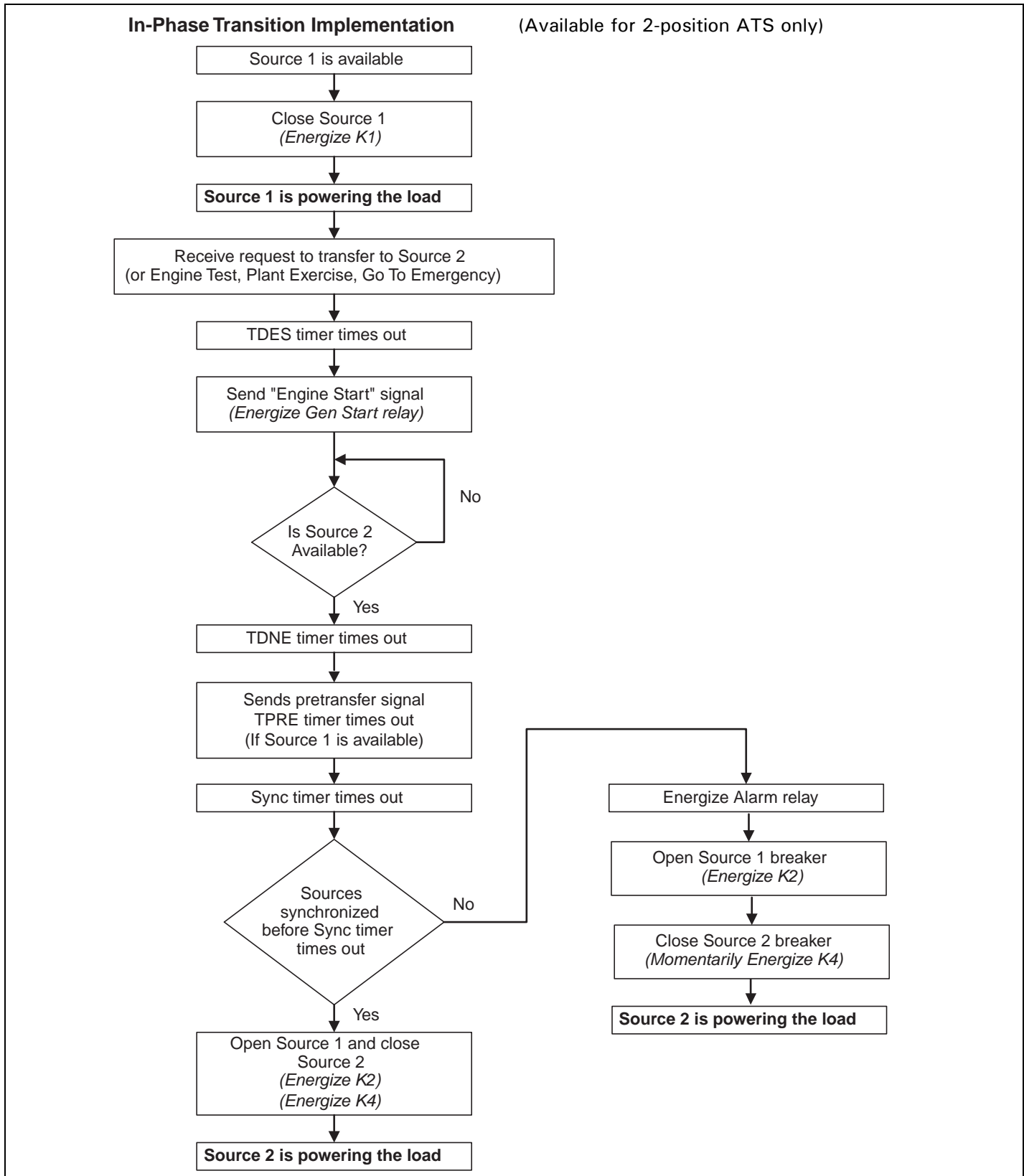

Figure 29. In-Phase Transition Implementation (Available for 2-position ATS Only).

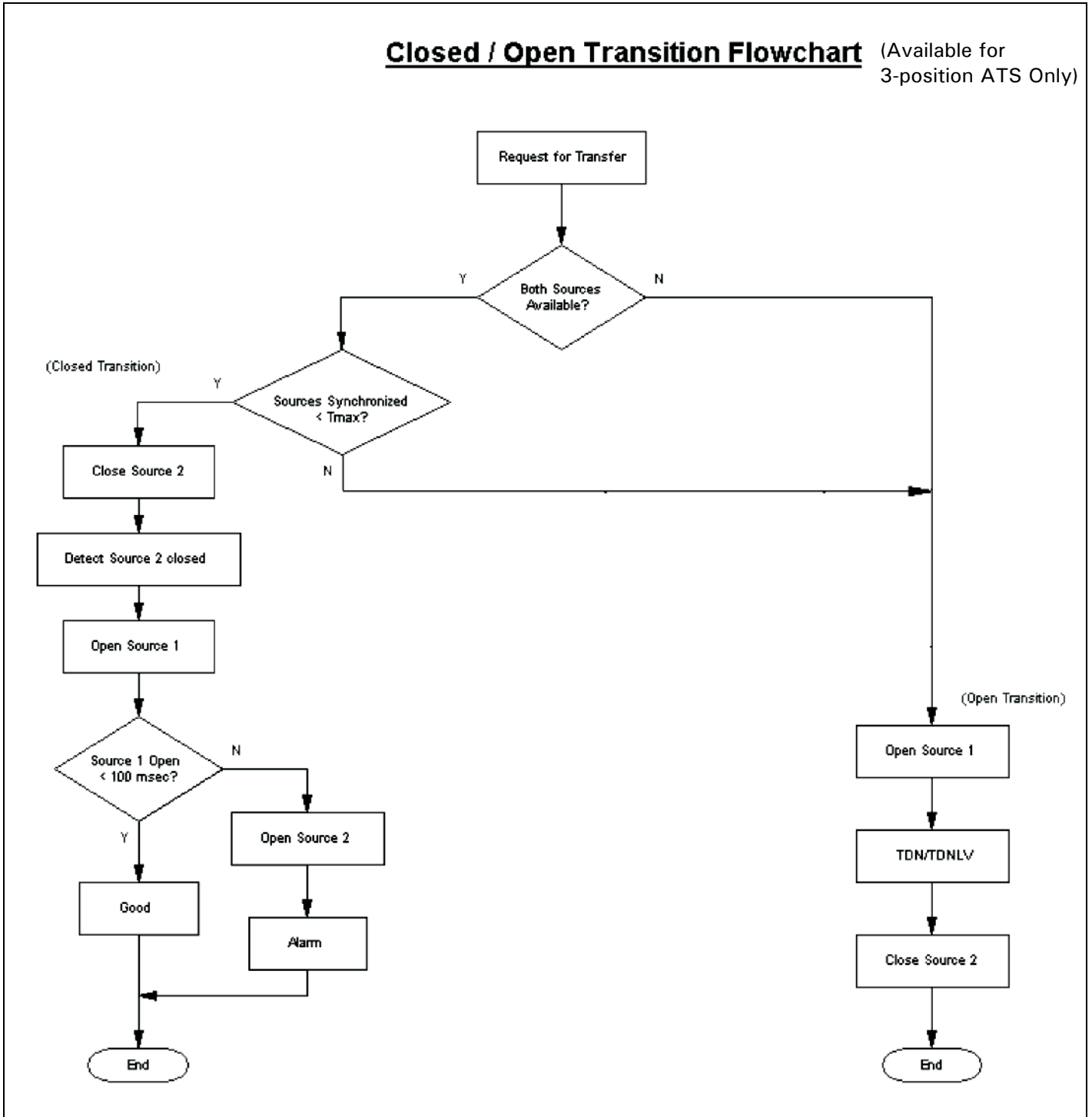

Figure 30. Closed/Open Transition Flowchart (Available for 3-position ATS Only).

This instruction booklet is published solely for information purposes and should not be considered all-inclusive. If further information is required, you should consult Eaton.

Sale of the product(s) shown in this literature is subject to terms and conditions outlined in appropriate Eaton selling policies or other contractual agreements between the parties. This literature is not intended to and does not enlarge or add to any such contract. The sole source governing the rights and remedies of any purchaser of this equipment is the contract between the purchaser and Eaton.

NO WARRANTIES, EXPRESSED OR IMPLIED, INCLUDING WARRANTIES OF FITNESS FOR A PARTICULAR PURPOSE OR MERCHANTABILITY, OR WARRANTIES ARISING FROM COURSE OF DEALING OR USAGE OF TRADE, ARE MADE REGARDING THE INFORMATION, RECOMMENDATIONS AND DESCRIPTIONS CONTAINED HEREIN. In no event will Eaton be responsible to the purchaser or user in contract, in tort (including negligence), strict liability or otherwise for any special, indirect, incidental or consequential damage or loss whatsoever, including but not limited to damage or loss of use of equipment, plant or power system, cost of capital, loss of power, additional expenses in the use of existing power facilities, or claims against the purchaser or user by its customers resulting from the use of the information, recommendations and description contained herein.

CSA is a registered trademark of the Canadian Standards Association. National Electrical Code and NEC are registered trademarks of the National Fire Protection Association, Quincy, Mass. NEMA is the registered trademark and service mark of the National Electrical Manufacturers Association. Uniform Building Code (UBC) is a trademark of the International Conference of Building Officials (ICBO). UL is a federally registered trademark of the Underwriters Laboratories Inc.

Eaton
Electrical Sector
1000 Eaton Boulevard
Cleveland, OH 45122I
United States
877-ETN-CARE (877-386-2273)
Eaton.com