

# Board of County Commissioners

## Okeechobee County



1700 NW 9<sup>th</sup> Avenue, Ste C  
Okeechobee, Florida 34972  
863-763-0805  
Fax 863-763-5529

### ADDENDUM NO. 1

Project Name: **Okeechobee County Project No. 2017-03  
Additions for The Landing Strip Café**

Date: **March 24, 2017**

This addendum forms part of the contract documents dated March 1, 2017, for the subject project as prepared by Okeechobee County. Please acknowledge receipt of the addendum in the Bid Proposal Form.

### ADDITIONS, MODIFICATIONS AND/OR CLARIFICATIONS TO THE PLANS AND SPECIFICATIONS

#### **I. INSTRUCTIONS:**

1. This Addendum shall be included as part of the original Contract Documents and the work required therein.
2. All work performed under this addendum shall be subject to the requirements of the Specifications and the Drawings for the work of this Project.
3. Submit written acknowledgement of receipt, understanding, and incorporation of all items of this addendum into the bid price along with the bid. ***Bids submitted without this written acknowledgement statement will be considered incomplete and disqualified.***

#### **Architect/ Pre-Bid Meeting Questions:**

1. Please clarify where temporary fencing is required?  
**TEMPORARY FENCING IS THE RESPONSIBILITY OF THE CONTRACTOR AS A "WAYS AND MEANS" OF CONSTRUCTION. THE CONTRACTOR WILL BE RESPONSIBLE TO SEPARATE THE CONSTRUCTION FROM THE DINING AREA DURING CONSTRUCTION. THE CONTRACTOR WILL BE REQUIRED TO STAGE THE WORK AROUND THE 6 AM TO 2 PM CAFÉ SCHEDULE, THE WORK WILL NEED TO BE COORDINATED WITH THE OWNER'S REPRESENTATIVE.**

2. What can be done to secure the large window opening during construction?  
**THE CONTRACTOR CAN USE THE OWNER SUPPLIED WINDOW SHUTTER SYSTEM AS A WAY TO SECURE THE FACILITY WHILE THE NEW GLASS IS WAITING TO BE INSTALLED. THE CONTRACTOR WILL BE REQUIRED TO MAKE THIS SYSTEM "AIR-TIGHT".**
3. Will a new ceramic floor be installed in the outside Dining area that is to be enclosed?  
**A NEW CERAMIC TILE FLOOR WILL BE INSTALLED IN THE NEW ENCLOSED DINING AREA. THE CONTRACTOR WILL REMOVE THE EXISTING MORTAR BED AND MATERIAL DOWN TO CONCRETE BASE. (SEE ATTACHED PARTIAL DETAIL SK-4)**
4. Will Drywall be installed at the new perimeter walls or match the bead board up to the ceiling?  
**DRYWALL TO BE INSTALLED AT THE NEW PERIMETER WALLS UP TO THE CEILING.**
5. Does the roof color have to match the existing metal roof?  
**THE METAL ROOF COLOR SHALL MATCH AS CLOSE AS POSSIBLE TO THE EXISTING ROOF.**

**RFI Questions:**

1. The model numbers for the Trane units are obsolete. The minimum is 14 SEER in the state of FL?  
**REFER TO REVISED MECHANICAL EQUIPMENT SCHEDULE ATTACHED.**
2. System 1 is calling for 1800 CFM. Its capacity is capable of 2200 CFM which would require a duct detector please advise?  
**NO DUCT DETECTOR REQUIRED.**
3. Will a test and balance be required?  
**YES, TESTING AND BALANCING CONTRACTOR SHALL PROVIDE EQUIPMENT AND PERSONNEL WHICH SPECIALIZE IN THE BALANCING AND TESTING OF HEATING, VENTILATING, AND AIR CONDITIONING SYSTEMS. THEY SHALL BALANCE AND ADJUST AIR MOVING EQUIPMENT AND AIR DISTRIBUTION AND EXHAUST SYSTEMS TO THE FLOW RATES INDICATED ON THE HVAC SCHEDULES AND PLANS.**
4. Will there be any new landscape/sod/irrigation for this project?  
**SOD, YES CONTRACTOR TO REPLACE WITH NEW BAHAI SOD WHERE EXISTING AREA HAVE BEEN AFFECTED BY CONSTRUCTION.  
 LANDSCAPE, NO NEW SCOPE OF WORK  
 IRRIGATION, NO NEW SCOPE OF WORK**
5. Can the County supply the vendor information for the CO2 that needs to be relocated on the P1 sheet?  
**SEE BELOW INFORMATION:  
 NuC02  
 2800 SE Market Place, Stuart, FL 34997  
 Phone: 800-472-2855**

6. Can the Architect provide the length of sidewalk going towards the parking lot at the new addition see sheet A-2?

**THERE IS APPROXIMATELY +/-42' OF SIDEWALK, SIDEWALK TO END AT THE PARKING LOT WITH A DETECTABLE WARNING STRIP BY "ULTRATECH ADA SURFACE MOUNT ADA PAD".**

7. The need for a temporary opening in the ceiling to remove the HVAC equipment and ductwork. That opening will need to be patched and painted. Will the entire ceiling be painted in this project?

**CONTRACTOR TO PAINT ALL INTERIOR CEILING IN THE FOOD PREP/STORAGE AREAS AND ALL DINING AREAS.**

8. There is no mention of painting the existing exterior of the building. Will this be required?

**NO, ONLY THE WALLS AND AREAS AFFECTED BY THE NEW CONSTRUCTION. PAINT TO MATCH EXISTING. THE OWNER WILL SUPPLY THE CONTRACTOR WITH THE PAINT INFORMATION FOR THE EXISTING PAINT.**

9. Is PGT Aluminum Storefront System "SS-3500" and "SE-3550" be allowed as a substitute for the window wall system?

**YES, PGT WILL BE AN ACCEPTABLE SUBSTITUTE, "ALL PROJECT SPECIFICATIONS MUST BE MET UPON SHOP DRAWING SUBMITTAL".**

10. My question is if the contract sum is under \$100K, do they still want P/P bonds or they just don't have to be on Standard Form 25.

**If the Contract Sum is more than \$100,000, the Contractor shall furnish a Performance Bond on Standard Form 25 in an amount equal to one hundred percent (100%) of the Contract Sum as security for the faithful performance of this Contract. If the Contract amount is increased, the Owner may require a corresponding increase in the amount of the bond. The Owner may also secure additional protection by directing the Contractor to add a penal amount to the existing bond or to obtain an additional bond. The Contractor shall furnish a Payment Bond on Standard Form 25-A in amount equal to one hundred percent (100%) of the Contract sum.**

**ATTACHMENTS:**

- PARTIAL SK-4 Plan Sheet**
- MECHANICAL EQUIPMENT SCHEDULE**
- Pre-Bid Meeting Sign-in Sheet**

**END OF ADDENDUM NO. 1**

This document must be signed by the bidder's authorized representative and permanently attached to the Bidder's Proposal (i.e. stapled) in its entirety. **Proposal submitted without Addendum and unsigned will be incomplete and will not be accepted.**

Name of Bidder : \_\_\_\_\_ Date: \_\_\_\_\_

By \_\_\_\_\_ Title: \_\_\_\_\_

# SHEET KEYNOTES

- 2 EXISTING STRUCTURE
- 10 NEW R-30 BATT INSULATION
- 11 NEW WOOD CROWN MOULDING TRIM TO MATCH EXISTING
- 12 NEW 5/8" DRYWALL
- 13 STOREFRONT WINDOW TO BE REMOVED

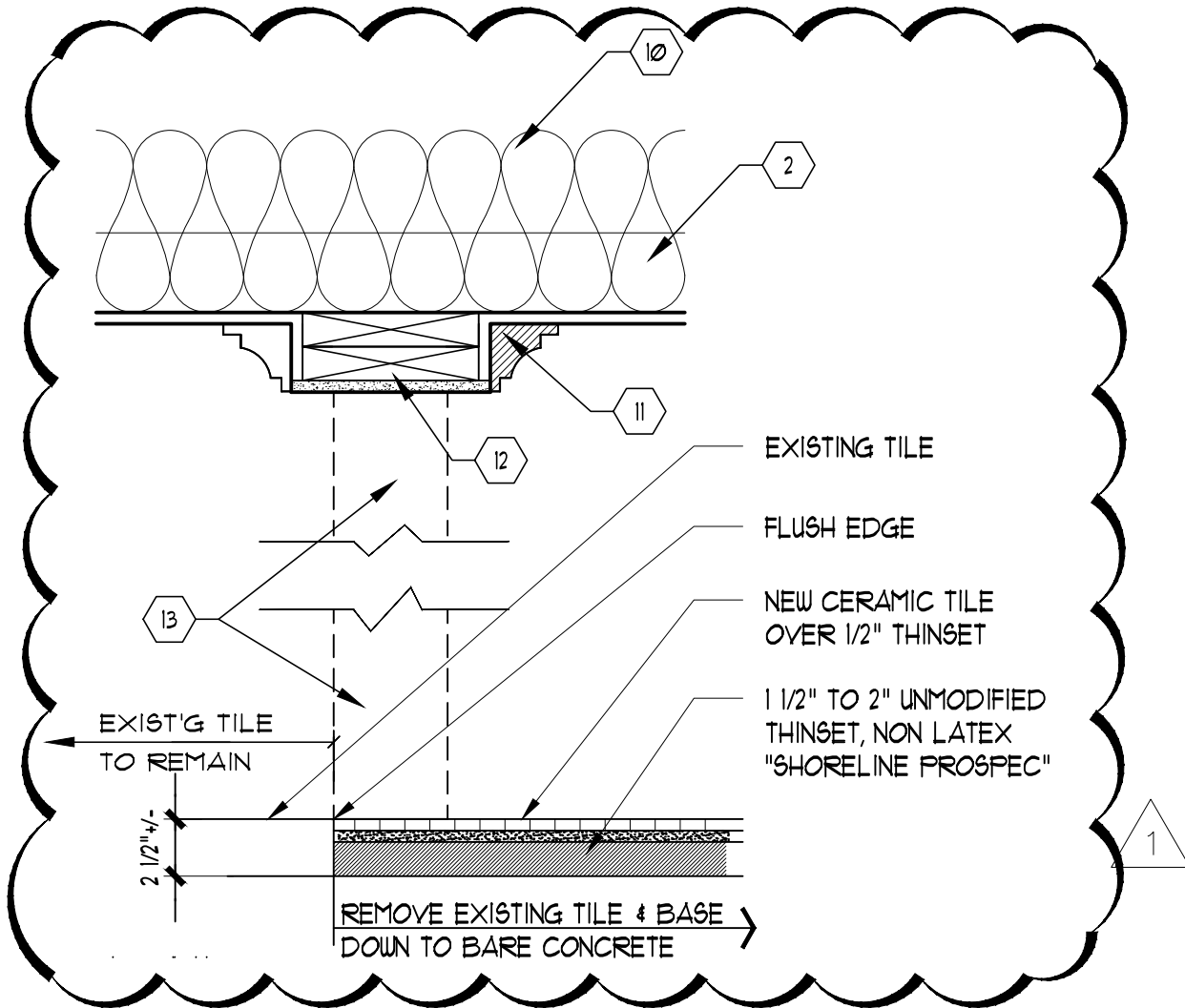

DETAIL 5/A-6

THE LANDING STRIP CAFE  
OKEECHOBEE FLORIDA

DRAWN CAH  
DATE 3/23/2017  
CHECKED J.P.T.

**JASON P. TRAMONTE**  
ARCHITECT

SHEET

SK = 4

REVISIONS

1625 SE 46TH STREET SUITE 2A CAPE CORAL, FLORIDA 33904  
(239) 549-0997 AA 26003258

OF 1 SHEETS

## MECHANICAL EQUIPMENT SCHEDULE

GENERAL					COOLING @ ARI				HEATING				MISC.	
MARK	MODEL	MANUFACTURER	CFM	OA	BTUH TOT	VOLTAGE	MCA	SEER/EER	KW	MODEL	STG.	VOLTAGE	MCA	REMARKS
NEW AHU1	TAM4A0AB60S51+TDR	TRANE	1800	444	55500	240/1	7.6	14.5	9.6	BAYEAAC10BK1A	1	240/1	40	1
NEW CU1	4TTR4060L1	TRANE	-	-	55500	240/1	31.0	14.5	-	-	-	-	-	2,3
NEW AHU2	TAM4A0B42S31+TDR	TRANE	1200	255	34800	240/1	2.4	14.5	4.8	BAYEAAC05	1	240/1	20	1
NEW CU2	4TTR4036L1	TRANE	-	-	34800	240/1	18.0	14.5	-	-	-	-	-	2,3
NEW AHU3	TAM4A0AB42S31+TDR	TRANE	1400	350	39500	240/1	2.7	14.0	7.68	BAYEAAC08	1	240/1	32	1
NEW CU3	4TTR4042L1	TRANE	-	-	39500	240/1	22.0	14.0	-	-	-	-	-	2,4

FURNISH THE FOLLOWING ITEMS AS INDICATED IN THE REMARKS COLUMN

1.) WALL MOUNTED PROGRAMMABLE THERMOSTAT.

2.) REFRIGERANT LINES TO BE SIZED BY THE MANUFACTURER FOR MINIMUM CAPACITY LOSS (PER TRANE REFRIGERANT PIPING MANUAL PUB. NO. 32-3009). PROVIDE ALL REFRIGERANT ACCESSORIES REQUIRED FOR A COMPLETE OPERABLE AND WARRANTED SYSTEM.

3.) MOUNT CU ON CONCRETE PAD @ OR ABOVE ZONED FLOOD.

ADDITIONS FOR THE LANDING STRIP CAFÉ  
 Mandatory Pre-Bid Meeting  
 PROJECT NO. 2017-03  
 March 14, 2017 @ 3:00 pm

REPRESENTATIVE	BUSINESS NAME	PHONE	EMAIL
Josh Della-Pietra	Ralph Della-Pietra, Inc.	561-745-8555	josk@RDPConstr.com
ELBERT BATTON	Platinum Performance Group	863-467-1933	elbert-platbuilders@gmail.com
Lori Bundy	Platinum Performance Gr	843-467-1933	loriplatbuilders@gmail.com
Wes Abney	Abney Building & Consulting	863-623-4459	wes@abneybuild.com
JOHN ABNEY	"	"	"
PAT SAVES	Native American Const.	561-781-6875	PAT@NATIVEAMERICANCONSTRUCTIONLLC.COM
ART CASTELLANOS	STASON FRAMMANTRE ANCHITREX	239-549-0997	ARTTHEARCHITECT@MSN.COM
Billy White	Seminole Design Build	863-801-0509	bwhite@sdbrteam.com
Kathy Scott	Oklechobee City	624-1474	Kscott@co.oklechobee.fl.us
Chris Rossi	Close Const. LLC	863-467-0831	ChrisRossi@CloseConstruction.us

Did attend  
 not attend