



REQUEST FOR BIDS

W.B. Casey WRRF Secondary Launder Covers

Bid Number 2022-WR-06

MARCH 2022

**CLAYTON COUNTY WATER AUTHORITY
1600 Battle Creek Road
Morrow, GA 30260**

Virtual Teams

Bid Opening Meeting: Tuesday, April 5, 2022 at 2:00 p.m. local time

Non-Mandatory Virtual Teams

Pre-Bid Meeting: Tuesday, March 22, 2022 at 2:00 p.m. local time

Non-Mandatory Site Visit: Wednesday, March 23, 2022 at 2:00 p.m. local time

This solicitation has a SLBE Bid Discount

Table of Contents

Division 1 General Overview

Section 1	Request for Bids.....	1-1.1
Section 2	General Information	1-2.1
2.1	Bid Overview	1-2.1
2.2	Bid Evaluation	1-2.1
2.3	Addendum	1-2.1

Division 2 Bid Requirements

Section 1	Instructions to Bidders.....	2-1.1
Section 2	Risk Management Requirements	2-2.1
Section 3	Bid Submittals	2-3.1
Section 4	Bid Form	2-4.1
Section 5	Georgia Bid Bond.....	2-5.1
Section 6	Bidder Qualification Information	2-6.1
Section 7	Contractor Affidavit & Agreement	2-7.1
Section 8	Small Local Business Enterprises (SLBE) General Information	2-8.1

Division 3 Contract Forms

Section 1	Agreement Form	3-1.1
Section 2	Performance Bond	3-2.1
Section 3	Payment Bond.....	3-3.1
Section 4	Non-Collusion Certificate	3-4.1
Section 5	Certification of Absence of Conflict of Interest for Development of Specifications of Scope of Work.....	3-5.1

Division 4 Specifications

Section 1	General Requirements	4-1.1
1.1	General.....	4-1.1
1.2	Work Items and Measurements.....	4-1.1
Section 2	Summary of Work	4-2.1
2.1	Project Location.....	4-2.1
2.2	Work Description	4-2.1
2.3	Special Requirements	4-2.2
2.4	Acceptance.....	4-2.2

Table of Contents

Drawings

Attachments W-9 Form
 Vendor Information Form
 Bid Package Label

Addenda (None issued at this time)

END OF TABLE OF CONTENTS

Division 1

General Information

Section 1: Request for Bids

Clayton County Water Authority
1600 Battle Creek Road
Morrow, Georgia 30260

Name of Project: **W.B. Casey WRRF Secondary Launder Covers**

The Clayton County Water Authority will open sealed bids on **Tuesday, April 5, 2022, at 2:00 p.m. (local time)** via a Virtual Teams Meeting, for the following project: **W.B. Casey WRRF Secondary Launder Covers**.

Any bids received after the specified time will not be considered.

A Non-Mandatory Pre-Bid Virtual Meeting will be held on **Tuesday, March 22, 2022, at 2:00 p.m. (local time)**.

Please use the following call-in instructions to attend the Pre-Bid and Bid Opening meetings:

[Join Microsoft Teams Meeting](#)

Phone Number: 912-483-5368

Conference ID: 598 580 73#

A Non-Mandatory Site Visit will take place on **Wednesday, March 23, 2022, at 2:00 p.m. local time** at 688 Flint River Road, Jonesboro, GA 30238.

As part of the effort to maintain the health and safety of Clayton County Water Authority (CCWA)'s personnel – as well as visitors – CCWA has put in place the following procedures, practices, and protocols:

- A: Each visitor shall complete the COVID-19 Health Assessment via DOCS Health Works. Download the DOCS Health Works app based on your device by going to the Apple Store or Google Play. DOCS Health Works is also available by internet at: <https://secure.dentrustocs.com/docs/covidscreening/weblogin>.
- B: Once the DOCS Health Works app is installed, click the icon to open the program. Complete the fields as follows:
- ID is VISITOR.
 - Location Code is GTW3.
 - Click Next. Enter your personal email and telephone number.
 - Create a 4-digit pin. Click Submit.
 - You are now registered in the system.

Division 1

General Information

Section 1: Request for Bids

- C: Complete the COVID-19 health assessment on the app or website. If everything is within normal parameters, you will receive a QR code for identification (this QR code is good for 24 hours).
- D: When you arrive to the facility, present the QR code to the CCWA staff.
- E: Visitor(s) are required to provide and wear their own face mask/covering while entering any structures. Face masks/covering are recommended but not required while outside unless the Visitors are unable to socially distance of at least six (6) feet during the visit.
- F: Visitor(s) shall practice physical (social) distancing while at the Project site by providing others a personal space of at least six (6) feet during the visit.

CCWA encourages Small Local, Minority and Women-Owned businesses to participate and respond to this bid request.

In an effort to promote responsible environmental practices the bid package is available in electronic (Adobe PDF) format and can be requested by calling 770-960-5223, M-F, 8:00 am - 5:00 pm or by e-mail to CCWA_Procurement@ccwa.us. A hardcopy bid package can also be requested at a cost of \$25.

*Clayton County Water Authority
By: Robin Malone, Chairperson*

END OF SECTION

Division 1

General Information

Section 2: General Overview

2.1 Bid Overview

This is an invitation to your firm to submit a sealed bid for supplying and installing Secondary Launder Covers at the W.B. Casey Water Resource Recovery Facility (WRRF) located at 688 Flint River Road, Jonesboro, GA 30238.

The bids shall be delivered or mailed in a sealed envelope to the Clayton County Water Authority (CCWA) at 1600 Battle Creek Road, Morrow, GA 30260, on or before Tuesday, April 5, 2022, at 2:00 p.m. (local time). Any and all bids received after this date and time will be considered unresponsive. The envelope shall be marked "Sealed Bid" and carry the bid title, date, and time of the bid opening (refer to General Instructions to Bidders). A Package Label has been provided for your convenience.

2.2 Bid Evaluation

It is the intent of CCWA to award this work to the responsive responsible bidder submitting the lowest bid complying with the conditions of this RFB document, and will be the most advantageous to the CCWA. Determination of best response to bid will be the sole judgment of the CCWA.

Bidders must submit pricing on all items on the Bid Form, otherwise, the bid will be deemed non-responsive.

This procurement has a SLBE bid discount for evaluation purposes only, which will be given to CCWA certified SLBE primes only. For more details, please refer to Division 2, Section 8 of this bid package.

2.3 Addendum

Bidders may ask questions regarding this contract prior to the bid opening. To be considered, all questions must be received in writing via email to **CCWA_Procurement@ccwa.us** by **2:00 p.m. on Monday, March 28, 2022**. Any and all responses to bidders' questions will be issued in the form of an Addendum by email. All addenda issued shall become part of the Bid Documents.

END OF SECTION

Division 2

Bid Requirements

Section 1: Instructions to Bidders

These instructions are to be followed by every entity proposing to provide the Clayton County Water Authority (CCWA) with goods and/or services. These instructions constitute an integral part of the bid, and any Bidder agrees that tender of a bid constitutes acknowledgment and acceptance of its obligation to adhere to these instructions, which are to be incorporated into and considered part of any contract the Bidder ultimately executes with the CCWA.

1. If there is any question whatsoever regarding any portion of the specifications, it shall be the Bidder's responsibility to seek clarification immediately from the CCWA, as early as possible prior to the bid opening. Regarding public works projects, requests for interpretations of specifications must be made in writing to the department proposing out the project not later than five (5) days prior to receipt of bids.
2. Unless it is otherwise stated in the bid documents, it shall be the responsibility of the bidder to inform itself as to all conditions of the work site and to make and take account thereof in calculating and submitting its bid. Documents may be made available by the CCWA during the bidding process; no warranty of accuracy is made in regard to these documents, and it is the responsibility of the bidder to make its own investigations as to the nature of the work and the conditions under which it shall be performed, and to make its own independent assumptions as to these matters. The burden of anticipating unforeseen circumstances, either hidden or latent, and the conditions of the work site and all related circumstances, and the cost of accommodating therefore should unanticipated circumstances be later encountered shall rest upon the bidder.
3. Pre-bid meeting or any other information session will be held at the location as indicated in the solicitation. Unless indicated otherwise, attendance is not mandatory; although vendors are strongly encouraged to attend. However, in the event the meeting is mandatory, then a representative of the vendor must attend the meeting in its entirety to be considered eligible for solicitation award. Late entry to the meeting will not be allowed.
4. In the event that, after the acceptance of a bid by the Board of Directors of the CCWA, any unsuccessful bidder wishes to contest such action, a written "Notice of Contest" must be filed with the General Manager no later than close of business on the 5th business day after the selection of successful bidder by the Board. Failure to timely file such notice shall forever preclude the filing of a contest of the award, or any civil action in the courts of the State of Georgia or of the United States.

Division 2

Bid Requirements

Section 1: Instructions to Bidders

5. Information submitted by the Bidder in the bid process shall be subject to disclosure after bid award in accordance with the Georgia Open Records Act. Proprietary information must be identified and be accompanied by a signed affidavit outlining the redacted information. Entire bids may not be deemed proprietary.
6. Bids must be made on the enclosed bid Form. Unless otherwise requested, one (1) original and at least two (2) copies of the bid Form need to be submitted, and these copies must be typewritten or printed in ink. All copies of any bid Forms must be signed in ink by the person or persons authorized to sign the bid Form. The person signing the bid Form must initial any changes or corrections.
7. The name of the person, firm, or corporation making the bid must be printed in ink, along with the Bidder's signature, on all separate sheets of the bid Form. If a bid is made by an individual, his name and post office address must be shown. If made by a firm, or partnership, the name and the post office address of each member of the firm or partnership must be shown. If made by a Corporation, the person or persons signing the bid must show the name of the State under the laws of which the Corporation is chartered and his, or their, authority for signing same. The names, titles and addresses of the President, Secretary and the Treasurer and the corporate authority for doing business in this state shall be listed and returned with the Bid Form.
8. All bids must be hand delivered, delivered by courier service, or mailed via the United States Postal Service. No facsimiles will be accepted. The person, firm, or corporation making the bid shall submit it in a sealed envelope on or before the date and time specified in the bid package. The envelope shall be marked "**Sealed Bid**" and carry the bid title, Contractor's License Number and date and time of opening as set forth in the bid package. The envelope shall also bear the name of the party making the bid and the party's address. Address bids to *Clayton County Water Authority, 1600 Battle Creek Road, Morrow, Georgia, 30260*. Even if a bid is not submitted, the bid form should be returned signed and with an explanation, otherwise the result will be deletion from the mailing list.
9. If published price books are a part of your bid, one price book must be included with your bid Form, and the successful Bidder is required to furnish additional current price books after award of the bid.
10. Alterations to the documents are strictly prohibited and shall result in automatic disqualification of the Bidder's bid. If there are "exceptions" to the specifications or comments to any of the solicitation requirements or other language, then the

Division 2

Bid Requirements

Section 1: Instructions to Bidders

bidder may ask questions regarding those requirements or submit additional documentation as to the variation from the specifications but may not alter any of the language contained in the solicitation.

11. In the case of goods, the person, firm or corporation making the bid may bid all items. All items may be considered separately, at the discretion of the CCWA.
12. Bids for public works whose price exceeds \$100,000.00 must be accompanied by a certified check, cashier's check, or acceptable bid bond in an amount not less than five percent (5%) of the amount bid.
13. In the case of equipment, these must be new and the most current model available. Determination of best bid response relies in part on the number of required specifications met.
14. In the event that no bidders meet specifications, the CCWA reserves the right to either reject all bids, or choose whichever equipment is most advantageous to CCWA.
15. Bidders for construction contracts where the laws of Georgia or the United States of America require a license in order to perform such construction must list the license number and class on the face of the bid envelope and must enclose copies of any required license with the bid.
16. When public work is let out for bid, no person shall prevent or attempt to prevent competition in such bid. Such Bidders must make an oath filed with the officer who makes payments under the contract that they have not prevented or attempted to prevent competition in the bid process. Such oath must be signed by: if a partnership, all partners and any officer or agent or other person who acted on the partnership's behalf during the bid process; if a corporation, all officers, agents, or other persons who acted for the corporation in the bid process.
17. Bids shall not be withdrawn or cancelled by the bidder past the bid opening date and time. The bidder may make modifications/corrections to the bid by submitting a corrected seal bid but only if the change is prior to the bid opening. The corrected document should be clearly marked that it supersedes the bid originally submitted. No modification or corrections will be allowed subsequent to the bid opening.
18. By tendering a bid, a Bidder agrees to leave the bid open for acceptance by the CCWA for ninety (90) days after the date set for the opening thereof.

Division 2

Bid Requirements

Section 1: Instructions to Bidders

19. By tendering a bid, the Bidder certifies that the Bidder has carefully examined these instructions and the terms and specifications applicable to and made a part of the bid. The Bidder further certifies that the prices shown in any schedule of items on which the Bidder is proposing are in accordance with the conditions, terms and specifications of the bid and that they are aware that any exception taken thereto may disqualify the bid. Bidders are required to inform themselves fully as to the availability of materials and the conditions relating to construction and labor under which any work will be or is now being performed. No error or misjudgment nor any lack of information on local conditions, general laws or regulations on the part of the Bidder shall merit withdrawal of the bid.
20. Copies of all communication pertaining to bids must be sent to the Contracts, Compliance and Risk Management Section.
21. The purpose of this bid is to establish contract prices. Unit price extension and net total must be shown if applicable. Cash discounts should be indicated separately. Any applicable sales taxes should be included in the unit prices for all materials to be provided by the successful Bidder.
22. Bidders are hereby notified and agree by submission of a bid Form that if additional items not listed in the bid Form become necessary and require unit prices not established by the bid Form, the unit prices of such items shall be negotiated and shall be directly proportional to the established unit prices of similar items in the bid Form.
23. All prices on goods shall be for delivery, our destination, f.o.b. freight prepaid Jonesboro, Georgia, and/or Morrow, Georgia, unless otherwise shown. Any deliveries shall be made as needed and requested throughout the contract period. The Bidder shall retain title for the risk of transportation, including filing for loss or damage. In case of critical need, if the successful bidder cannot deliver the goods upon CCWA's urgent demands, CCWA reserves the right to pick up the goods from the bidder at a discount.
24. Quantities when shown are estimates only, based on anticipated needs. The CCWA reserves the right to purchase more or less based on actual need at contract price. If a Bidder intends to offer minimum or maximum shipment quantities, such intent and such quantities should be specified on the bid Form. Otherwise, none will be assumed.
25. The time for completion of the work is stated in the bid Form. Failure to complete the work within this period shall result in payment to the CCWA of liquidated

Division 2

Bid Requirements

Section 1: Instructions to Bidders

- damages in an amount provided for by contract for each calendar day in excess of the Contract time.
26. The Bidder must employ such methods and means in carrying out the work as will not cause any interruption of or interference with any other Bidder.
 27. The successful Bidder must comply with the applicable Risk Management Requirements prior to beginning performance, and during the contract period.
 28. The Contract between the CCWA and the Bidder shall be executed on a form provided by CCWA and will be subject to all requirements of the contract documents (which include but may not be limited to the Contract, these instructions, any Purchase Orders, and the Risk Management Requirements), and shall form a binding contract between the contracting parties.
 29. Failure to execute the Contract, any required Surety Performance and Payment Bonds, or to furnish any required satisfactory proof of carriage of required insurance within ten (10) days from the date of notice of award of the Contract shall be just cause for the annulment of the award and for forfeiture of the bid guaranty to the CCWA, not as a penalty, but in liquidation of damages sustained. At the discretion of the CCWA, the award may then be made to the next lowest responsible vendor, or the work may be re-advertised or constructed by the CCWA.
 30. Any Contract and Contract Bonds shall be executed in duplicate.
 31. Award of this bid shall be by action of the CCWA Board at its regular monthly meeting.
 32. The CCWA reserves the right, with or without notice or cause, to accept any bid regardless of the cost thereof; to reject any bid, or any number of bids; to negotiate with any Bidder for a reduction of or alterations in its bid; to reject all bids and to call for additional bids upon the same or different invitations to bid, plans or specifications; to be sole judge, in its discretion, on all questions as to whether or not a bid complies with the invitation to bid, the plans or the specifications, and as to the solvency and sufficiency of any and all sureties on all bonds.
 33. The apparent low bid for goods shall be considered to be the lowest aggregate total price of specified products at their unit prices times the estimated required quantities of these specified products.

Division 2

Bid Requirements

Section 1: Instructions to Bidders

34. Bids received from two (2) or more vendors that are identical in price, delivery and meet the requirements of the bid specifications shall be awarded on the following basis:
 - a. The bid submitted by a vendor who does not have a documented negative vendor performance record.
 - b. The bid submitted by a vendor who is located within Clayton County.
 - c. The bid submitted by a vendor who is certified by our Small Local Business Enterprise Program.
 - d. If the tie bids meet all the above criteria, and it is not in CCWA's best interest (at its sole discretion) to split the award, the bid award is based on the toss of a coin by CCWA staff in a public session. The vendors involved will be invited to attend the coin toss at a stated date and time. One or more witnesses from both CCWA Procurement and the Request Department may be present. A simple coin toss (called by the vendor listed first in the alphabet) will break the tie and decide the award.
35. While price is the prime criteria, and the CCWA intends to purchase at the lowest responsible bid available, price shall not be the sole criteria utilized by the CCWA in evaluating the bid package submitted. The following criteria shall also be utilized by the CCWA in determining the lowest responsible bid:
 - a. Ability of bidder to perform in the time frame needed by the CCWA.
 - b. Reputation of the bidder in its industry.
 - c. Reasonableness of the bid in relation to anticipated costs.
 - d. Ongoing relationships with the CCWA based on above-average prior performance of work with CCWA.
 - e. Preference for local vendors where there is no significant variance in price or service.
36. Bidders are notified that CCWA reserves the right except in the case of public works contracts to include among the factors considered in awarding the contract the proximity of each Bidder's place of business to any affected Authority facility. CCWA further reserves the right to award the contract to a Bidder other than the Bidder offering the lowest price where: (a) the difference in price between the low Bidder and the preferred Bidder is nominal; and (b) CCWA's Board determines that the preferred bid provides the most cost effective option due to the closer proximity of the preferred Bidder's place of business to the affected Authority

Division 2

Bid Requirements

Section 1: Instructions to Bidders

facility or facilities. In such a situation, by responding to this bid, the Bidder waives any cause of action against CCWA for frustration of bid or under any similar legal theory; furthermore, the Bidder agrees to pay all costs and expenses, including but not limited to attorney fees, incurred by CCWA in defending against any such claim.

37. It is the policy of the Clayton County Water Authority (CCWA) to promote award of sub-agreements for goods and/or services to qualified minority and women-owned businesses. Bidders are encouraged to solicit minority and women-owned businesses whenever they are potential sources.
38. Bidders are encouraged to utilize the services and assistance of the U.S. Small Business Administration (SBA), and the office of the Department of Commerce Minority Business Development Agency (MBDA). These agencies can provide assistance in securing the names of qualified minority and women-owned businesses. Additionally, it is encouraged that bidders access certified Small Local Business Enterprise (SLBE) vendors from Clayton County, DeKalb County, and City of Atlanta.

The Georgia Department of Transportation (DOT) has established a list of qualified Disadvantaged Business Enterprises. Information is available online under the tab for "Directories", link for "UCP Directory - Excel" at:
<http://www.dot.ga.gov/PS/Business/DBE>.

The successful Bidder will be asked to provide, along with his Request for Payment each month a list of qualified SLBE and MBE/WBE businesses utilized on this Project.

GEORGIA SECURITY AND IMMIGRATION COMPLIANCE ACT OF 2006

39. Pursuant to the Georgia Security and Immigration Compliance Act of 2006, the successful Bidder understands and agrees that compliance with the requirements of O.C.G.A.13-10-91 and Georgia Department of Labor Rule 300-10-02 are conditions of this bid and contract document. The Bidder further agrees that such compliance shall be attested by the Bidder and any of his Subcontractors by execution of the appropriate Affidavit and Agreement included after the Agreement Form of these documents.

END OF SECTION

Division 2

Bid Requirements

Section 2: Risk Management Requirements

The Contractor will provide minimum insurance coverage and limits as per the following: The Contractor will file with the Authority Certificates of Insurance, certifying the required insurance coverages and stating that each policy has been endorsed to provide thirty (30) day notice to the Authority in the event that coverage is cancelled, non-renewed or the types of coverage or limits of liability are reduced below those required. All bonds and insurance coverage must be placed with an insurance company approved by Authority Management, admitted to do business in the State of Georgia, and rated Secure (“B+” or better) by A.M. Best Company in the latest edition of Property and Casualty Ratings, or rated by Standard & Poors Insurance Ratings, latest edition as Secure (“BBB” or better). Worker’s Compensation self-insurance for individual Contractors must be approved by the Worker’s Compensation Board, State of Georgia and/or Self-Insurance pools approved by the Insurance Commissioner, State of Georgia.

CONTRACTS FOR UP TO \$50,000

Worker’s Compensation – Worker’s Compensation coverage on a statutory basis for the State of Georgia with an Employer’s Liability limit of \$100,000 each Accident, Disease \$100,000 each employee, \$500,000 Disease policy limit.

Automobile Liability – Automobile liability coverage for owned, hired and non-owned vehicles in the amount of \$500,000 combined single limit.

Commercial General Liability – Coverage to be provided on “occurrence” not “claims made” basis. The coverage is to include Contractual liability, Per Project Limit of Liability, losses caused by Explosion, Collapse and Underground (“xcu”) perils, the “Clayton County Water Authority” is to be added as an Additional Insured and Products and Completed Operations coverage is to be maintained for three (3) years following completion of work.

CONTRACTS FOR MORE THAN \$50,000

Worker’s Compensation – Worker’s Compensation coverage on a statutory basis for the State of Georgia with an Employer’s Liability limit of \$1,000,000. The increased Employer’s Liability limit may be provided by an Umbrella or Excess Liability policy.

Automobile Liability - Automobile liability coverage for owned, hired and non-owned vehicles in the amount of \$1,000,000 combined single limit.

Commercial General Liability – Coverage to be provided on “occurrence” not “claims made” basis. The coverage is to include Contractual liability, Per Project Limit of Liability, losses caused by Explosion, Collapse and Underground (“xcu”) perils, the “Clayton County Water Authority” is to be added as an Additional Insured and Products and Completed Operations coverage is to be maintained for three (3) years following completion of work.

Division 2

Bid Requirements

Section 2: Risk Management Requirements

RISK MANAGEMENT REQUIREMENTS (Cont'd)

CONTRACTS FOR UP TO \$50,000

CONTRACTS FOR MORE THAN \$50,000

LIMITS OF LIABILITY:

\$1,000,000	Per Occurrence
\$1,000,000	Personal and Advertising
\$50,000	Fire Damage*
\$5,000	Medical Payments*
\$1,000,000	General Aggregate
\$1,000,000	Products/Completed Operations per Occurrence and Aggregate

**These are automatic minimums*

Owner's Protective Liability – The Authority Management's may, in its discretion, require Owner's Protective Liability in some situations.

Umbrella and/or Excess Liability – The umbrella or Excess Liability Policy may be used to combine with underlying policies to obtain the limits required. The Management of the Authority may elect to require higher limits.

Owner's Protective Liability – The Authority Management's may, in its discretion, require Owner's Protective Liability in some situations.

END OF SECTION

Division 2

Bid Requirements

Section 3: Bid Submittals

3.1 Required Bid Submittals:

The following items are required to be included as part of the bid submittal. Failure to include any of these items may result in the bid being deemed non-responsive. The required items include but are not limited to:

- A. Bid Form – Bidders must submit their completed and signed Bid Form.
- B. Georgia Bid Bond in the amount of 5% of the total bid amount – if applicable.
- C. Bidder Qualification Information Form, including References.
- D. Georgia Security and Immigration Compliance Act of 2006 form.
- E. Contractor Affidavit and Agreement form.
- F. Subcontractor Affidavit form.

If a Contractor/Subcontractor will not be performing any services under this contract, the Contractor/company submitting the bid MUST also complete, sign, date, and have both Affidavit forms notarized and make proper notation of "N/A" - Not Applicable.

Clayton County Water Authority (CCWA) cannot consider any bid which does not include completed affidavits. It is not the intent of this notice to provide detailed information or legal advice concerning the Georgia Security & Immigration Compliance Act of 2006, as amended on May 11, 2009. All Bidders intending to do business with CCWA are responsible for independently apprising themselves and complying with the requirements of that law and its effect on CCWA procurements and their participation in those procurements.

- G. SLBE Forms. An indication of "N/A" for "not applicable" must be noted as appropriate.
- H. Non-Collusion Certificate.
- I. Certification of Absence of Conflict of Interest for Development of Specifications of Scope of Work.
- J. W-9 Form.
- K. Vendor Information Form.
- L. Copies of any and all license(s) required to perform the work.
- M. Any other items as required in this RFB including but not limited to these items contained in the Instructions to Bidders.
- N. Addenda (all addenda issued).

END OF SECTION

Division 2

Bid Requirements

Section 4: Bid Form

Bid of _____

(Hereinafter "Bidder"), organized and existing under the laws of the State of _____,
doing business as _____ (insert "a corporation",
"a partnership", or "an individual", or such other business entity designation as is
applicable).

To the Clayton County Water Authority (hereinafter "CCWA").

In compliance with the Request for Bids, Bidder hereby proposes to perform all Work for
W.B. Casey WRRF Secondary Launder Covers in strict accordance with the Contract
Documents as enumerated in the Request for Bids, within the time set forth therein, and
at the prices stated below.

By submission of this bid, Bidder certifies, and in the case of joint bid each party thereto
certifies as to the party's own organization that this bid has been arrived at independently,
without consultation, communication, or agreement as to any matter relating to this bid
with any other Bidder or with any competitor. Bidder also certifies compliance with the
Instructions to Bidders.

In submitting this bid, Bidder certifies Bidder is qualified to do business in the state of
Georgia as required by laws, rules, and regulations or, if allowed by statute, covenants to
obtain such qualification prior to contract award.

CONTRACT EXECUTION AND BONDS:

The undersigned Bidder agrees, if this bid is accepted, to enter into an Agreement with
CCWA on the form included in the Contract Documents to perform and furnish Work as
specified or indicated in the Documents for the Contract Price derived from the bid and
within the times indicated herein and in accordance with the other terms and conditions
of the Documents.

Bidder accepts the terms and conditions of the Documents.

INSURANCE:

Bidder further agrees that bid amount(s) stated herein includes specific consideration for
the specified insurance coverages.

Division 2

Bid Requirements

Section 4: Bid Form

CONTRACT TIME:

Bidder hereby agrees to commence work by executing the agreement within fourteen (14) calendar days of Notice of Award or as specified by the CCWA. The contract shall be completed within thirty (30) calendar days from the Notice to Proceed. The Contractor and the CCWA recognize that time is of the essence in completing this work and that there are delays, expense and difficulties involved in resolving a dispute related to a loss suffered by the CCWA if the Work is not completed on time. Accordingly, instead of requiring such proof, the CCWA and the Contractor agree that as liquidated damages for delay (but not as a penalty), the Contractor shall pay to the CCWA, as liquidated damages the amount of Two Hundred Fifty Dollars (\$250.00) per calendar day for each and every day or part of a day thereafter that said work remains substantially incomplete.

ADDENDA:

Bidder acknowledges receipt of the following Addenda:

SURETY:

This project work will require Performance and Payment Bonds prior to the commencement of the work. Such work shall not commence until approval of such bonds has been given by the CCWA.

BID:

The undersigned proposes to complete, in all respects, sound, complete and conformable with this Contract Document the following work for the following amounts.

Division 2

Bid Requirements

Section 4: Bid Form

BID FORM

Bidders must provide pricing for items 1 – 3 below, and enter a TOTAL BID AMOUNT by adding the Cost column for Items 1 – 4:

ITEM NO.	DESCRIPTION	QUANTITY	COST (In Figures)
1	Mobilization	1 LS	\$
2	Installation of Launder Covers for One (1) Secondary Basin	1 LS	\$
3	Site Clean Up and Demobilization	1 LS	\$
4	Unforeseen Existing Conditions Allowance	1 LS	\$ 10,000.00
TOTAL BID AMOUNT			\$

Submitted by:

COMPANY NAME OF BIDDER

Is your company a CCWA Certified SLBE? Yes _____ No _____

County: _____

Division 2

Bid Requirements

Section 4: Bid Form

Submitted by:

(NAME OF BIDDER)

By: _____
(SIGNATURE)

(TITLE)

(DATE)

(SEAL)
(ATTEST)

(ADDRESS)

(PHONE NUMBER)

(LICENSE NUMBER) (If applicable)

(E-MAIL ADDRESS)

END OF SECTION

Division 2

Bid Requirements

Section 5: Georgia Bid Bond

BOND NO. _____

KNOW ALL MEN BY THESE PRESENTS, that _____

herein after called the PRINCIPAL, and _____

a corporation duly organized under the laws of the State of _____

having its principal place of business at _____

_____ in the State of _____

and authorized to do business in the State of Georgia as SURETY, are held and firmly bound unto Clayton County Water Authority, as OWNER, hereinafter called the OBLIGEE, in the amount of five percent (5%) of the Total Bid Amount for the payment for which we bind ourselves, our heirs, executors, administrators, successors, and assigns, jointly and severally, firmly by these presents.

THE CONDITION OF THIS BOND IS SUCH THAT:

WHEREAS, the Principal is herewith submitting his or its Bid for the **W.B. Casey WRRF Secondary Launder Covers** project, and said Bid, by reference thereto, being hereby made a part hereof.

WHEREAS, the PRINCIPAL contemplates submitting or has submitted a Bid to the OBLIGEE for the furnishing of all labor, materials (except those to be specifically furnished by the Owner), equipment, machinery, tools, apparatus, means of transportation for, and the performance of the work covered in the Bid and the documents, titled: **W.B. Casey WRRF Secondary Launder Covers.**

Division 2

Bid Requirements

Section 5: Georgia Bid Bond

WHEREAS, it was a condition precedent to the submission of said Bid that a cashier's check, certified check, or Bid Bond in the amount of five percent (5%) of the Total Bid Amount be submitted with said Bid as a guarantee that the Bidder would, if awarded the Contract, enter into a written Contract with the Owner for the performance of said Contract, within 10 consecutive calendar days after written notice having been given of the award of the Contract.

NOW THEREFORE, the conditions of this obligation are such that if the PRINCIPAL within 10 consecutive calendar days after written notice of such acceptance, enters into a written Contract with the OBLIGEE and furnishes a Performance Bond and Payment Bond in an amount equal to one hundred percent (100%) of the contract amount, satisfactory to the Owner, then this obligation shall be void; otherwise the sum herein stated shall be due and payable to the OBLIGEE and the SURETY herein agrees to pay said sum immediately upon demand of the OBLIGEE in good and lawful money of the United States of America, as liquidated damages for failure thereof of said PRINCIPAL.

Signed and sealed this _____ day of _____ 20_____.

PRINCIPAL

By _____

SURETY

By _____
Attorney-In-Fact

END OF SECTION

Division 2

Bid Requirements

Section 6: Bidder Qualification Information

COMPANY NAME OF BIDDER: _____

NUMBER OF YEARS IN BUSINESS _____

BUSINESS ADDRESS OF COMPANY: _____

TELEPHONE NUMBER: _____

POINT OF CONTACT NAME: _____

POINT OF CONTACT EMAIL ADDRESS: _____

COMPANY TAX ID NUMBER: _____

COMPANY WEBSITE: _____

- ENTITY TYPE: Individual/Sole Proprietor Employee Owned Company
 Privately Held Corporation/LLC Partnership
 Publicly Owned Company Attorney
 Other (specify): _____

NAME OF PRINCIPAL OFFICERS: _____

Division 2

Bid Requirements

Section 6: Bidder Qualification Information

REFERENCES

LIST AT LEAST 3 REFERENCES OF SIMILAR EXPERIENCE COMPLETED IN THE PAST 5 YEARS:

COMPANY/GOV'T ENTITY NAME: _____
CONTACT NAME: _____
ADDRESS: _____
PHONE NUMBER: _____

COMPANY/GOV'T ENTITY NAME: _____
CONTACT NAME: _____
ADDRESS: _____
PHONE NUMBER: _____

COMPANY/GOV'T ENTITY NAME: _____
CONTACT NAME: _____
ADDRESS: _____
PHONE NUMBER: _____

COMPANY/GOV'T ENTITY NAME: _____
CONTACT NAME: _____
ADDRESS: _____
PHONE NUMBER: _____

COMPANY/GOV'T ENTITY NAME: _____
CONTACT NAME: _____
ADDRESS: _____
PHONE NUMBER: _____

END OF SECTION

Division 2

Bid Requirements

Section 7: Contractor Affidavit and Agreement

GEORGIA SECURITY AND IMMIGRATION COMPLIANCE ACT OF 2006

- A. Pursuant to the Georgia Security and Immigration Compliance Act of 2006, the Contractor understands and agrees that compliance with the requirements of O.C.G.A. § 13-10-91 and Georgia Department of Labor Rule 300-10-.02 are conditions of this Agreement. The Contractor further agrees that such compliance shall be attested by the Contractor through execution of the contractor affidavit required by Georgia Department of Labor Rule 300-10-1-.07, or a substantially similar contractor affidavit. The Contractor's fully executed affidavit is attached hereto as Exhibit ____ and is incorporated into this Agreement by reference herein.

- B. By initialing in the appropriate line below, the Contractor certifies that the following employee-number category as identified in O.C.G.A. § 13-10-91 is applicable to the Contractor:
 - 1. _____ 500 or more employees.
 - 2. _____ 100 or more employees.
 - 3. _____ Fewer than 100 employees.

- C. The Contractor understands and agrees that, in the event the Contractor employs or contracts with any subcontractor or subcontractors in connection with this Agreement, the Contractor shall:
 - 1. Secure from each such subcontractor an indication of the employee-number category as identified in O.C.G.A. § 13-10-91 that is applicable to the subcontractor.
 - 2. Secure from each such subcontractor an attestation of the subcontractor's compliance with O.C.G.A. § 13-10-91 and Georgia Department of Labor Rule 300-10-1-.02 by causing each such subcontractor to execute the subcontractor affidavit required by Georgia Department of Labor Rule 300-10-1-.08, or a substantially similar subcontractor affidavit. The Contractor further understands and agrees that the Contractor shall require the executed subcontractor affidavit to become a part of the agreement between the Contractor and each such subcontractor. The Contractor agrees to maintain records of each subcontractor attestation required hereunder for inspection by the Clayton County Water Authority at any time."

Contractor _____

Authorized Signature: _____

Name: _____

Title: _____

Date: _____

Division 2

Bid Requirements

Section 7: Contractor Affidavit and Agreement

CONTRACTOR AFFIDAVIT AND AGREEMENT

By executing this affidavit, the undersigned contractor verifies its compliance with [O.C.G.A. 13-10-91](#), stating affirmatively that the individual, firm, or corporation which is contracting with the Clayton County Water Authority has registered with, is participating in, uses, and will continue to use for the duration of the contract, the federal work authorization program - EEV/Basic Pilot Program operated by the U. S. Citizenship and Immigration Services Bureau of the U.S. Department of Homeland Security, in conjunction with the Social Security Administration (SSA), commonly known as E-Verify, in accordance with the applicability provisions established in [O.C.G.A. 13-10-91](#).

The undersigned further agrees that, in connection with the physical performance of services pursuant to this contract with the Clayton County Water Authority, the contractor will only employ or contract with subcontractor(s), who can present a similar affidavit verifying the subcontractor's compliance with [O.C.G.A. 13-10-91](#). Contractor further agrees to maintain records of such compliance and provide a copy of each such verification to the Clayton County Water Authority within five days of the subcontractor(s) presenting such affidavit(s) to the contractor.

EEV / Basic Pilot Program* User Identification Number
Enter the four to seven-digit number

BY: Authorized Officer or Agent
(Contractor Name)

Date

Title of Authorized Officer or Agent of Contractor

Printed Name of Authorized Officer or Agent

SUBSCRIBED AND SWORN BEFORE ME ON THIS
THE _____ DAY OF _____ 20_____.

Notary Public

My Commission Expires

Division 2

Bid Requirements

Section 7: Contractor Affidavit and Agreement

SUBCONTRACTOR AFFIDAVIT AND AGREEMENT

By executing this affidavit, the undersigned subcontractor verifies its compliance with [O.C.G.A. 13-10-91](#), stating affirmatively that the individual, firm or corporation which is engaged in the physical performance of services under a contract with _____ on behalf of the Clayton County Water Authority has registered with, is participating in, uses, and will continue to use for the duration of the contract the federal work authorization program - EEV/Basic Pilot Program operated by the U. S. Citizenship and Immigration Services Bureau of the U.S. Department of Homeland Security, in conjunction with the Social Security Administration (SSA), commonly known as E-Verify, in accordance with the applicability provisions and deadlines established in [O.C.G.A. 13-10-91](#).

The undersigned further agrees that, in connection with the physical performance of services pursuant to this contract with _____ on behalf of the Clayton County Water Authority, the subcontractor will only employ or contract with sub-subcontractor(s), who can present a similar affidavit verifying the sub-subcontractor’s compliance with [O.C.G.A. 13-10-91](#). The undersigned further agrees that the Subcontractor will maintain records of such compliance and provide a copy of each such verification to the Contractor within five days of the sub-subcontractor(s) presenting such affidavit(s) to the Sub-contractor.

EEV / Basic Pilot Program* User Identification Number
Enter the four to seven-digit number

BY: Authorized Officer or Agent
(Subcontractor Name)

Date

Title of Authorized Officer or Agent of Subcontractor

Printed Name of Authorized Officer or Agent

SUBSCRIBED AND SWORN BEFORE ME ON THIS THE _____ DAY OF _____
20____.

Notary Public

My Commission Expires

END OF SECTION

Division 2 **Bid Requirements**

Section 8: Small Local Business Enterprises (SLBE) - General Information

8.1 Program Overview

Clayton County Water Authority (CCWA) has implemented a Small Local Business Enterprise Program to promote full and open competition in all government procurement and purchasing. Bid discounts for the use of Small Local Business Enterprises (SLBE's) are set on a contract by contract basis for each specific prime contract with subcontracting possibilities. CCWA wants to ensure that Bidders are non-discriminatory in their process of selecting sub-contractors. CCWA also wants to encourage Bidders to utilize small, minority or woman-owned businesses whenever possible. All forms included in this solicitation must be completed for Bidder to be considered responsive.

SLBE means a locally-based small business operating inside or outside of Clayton County, which meets the following criteria:

- A) Independently owned and operated business concern whose average annual gross receipts for the previous three years must not exceed (1) Construction Firms – \$18,250,000; (2) Professional Services Firms – \$5,500,000; (3) Architectural Firms – \$3,750,000; (4) Engineering Firms – \$7,500,000, and (5) Goods and Services – less than 250 employees.
- B) Locally based, meaning located and operating in Clayton County or the ten (10) counties of Cherokee, Cobb, DeKalb, Douglas, Fayette, Fulton, Gwinnett, Henry, Rockdale and Spalding for at least one year prior to submitting application for certification.

If a firm is locally-based in one of the counties mentioned above, is currently certified as a small business through Clayton County, the City of Atlanta, DeKalb County, or the Georgia Department of Transportation, and can provide evidence of its certification, the firm will be provisionally accepted as a SLBE, provided that they complete the official certification application for CCWA within two (2) years following the date of provisional certification. If a firm meets these qualifications, but is not currently certified as a CCWA small local business, then the firm must complete an application for certification with CCWA no later than seven (7) business days following the deadline for bid submission.

SLBE's must perform a commercially useful function, which means performance of provision of real and actual services under the contract or subcontract with CCWA. Factors such as the nature and amount of the work subcontracted; whether the SLBE has the skill and expertise to perform the work for which it has been certified; whether the SLBE actually performs, manages or supervises the work; and whether the SLBE intends to purchase commodities and/or services

Division 2 **Bid Requirements**

Section 8: Small Local Business Enterprises (SLBE) - General Information

from a non-SLBE and simply resell them will be considered in determining if the SLBE is performing a commercially useful function.

Participation in the SLBE program is not a requirement to participate in contracting with CCWA. The use of an SLBE is a requirement when bid discounts are to be sought. The Bidder will be required to complete the required forms as outlined in the following section.

8.2 Overview of Bid Discount

Bid discounts are incentives that allow an original bid amount to be discounted for evaluation purposes in determining the lowest responsive, responsible bidder, while the original bid amount will be the basis for contract award.

Example: A \$100,000 bid with a 7.5% bid discount would be evaluated at \$92,500. However, \$100,000 would be paid to the successful bidder.

Bid Discounts will be applied to CCWA certified SLBE prime bidders only. *The use of certified SLBE sub-contractors will not establish eligibility to receive Bid Discounts.* Depending on the bidder's location, Bid Discounts will range between 7.5% and 10%.

The calculation of SLBE bid discounts shall be as follows:

There will be an applied tiered discount to bids based on what county the SLBE business is located.

- 10 percent for SLBE's in Clayton County.
 - 7.5 percent for SLBE's within the next surrounding 10 counties (Cherokee, Cobb, DeKalb, Douglas, Fayette, Fulton, Gwinnett, Henry, Rockdale and Spalding).
- (1) Discounts are given to Bidders who are SLBE prime bidders only.
 - (2) In the event of a tie bid between a discounted bidder and a non-discounted bidder, the discounted bidder (SLBE) will be recommended for the contract.

By signing the bid, the bidder is certifying that he/she has complied with the requirements of this program. Please contact Contracts, Compliance and Risk Management at ccwa_slbe_program@ccwa.us for more information on CCWA's SLBE Program or visit our website at www.ccwa.us.

END OF SECTION

Division 3

Contract Forms

Section 1: Agreement Form

**STATE OF GEORGIA
COUNTY OF CLAYTON**

**AGREEMENT FOR SINGLE PURCHASE
OF GOODS AND SERVICES**

This Agreement made and entered into this ____ day of _____, 20____, for W.B. Casey WRRF Secondary Launder Covers, between the **CLAYTON COUNTY WATER AUTHORITY** (hereinafter "the Authority") and _____ (hereinafter "the Contractor"), witnesseth.

WHEREAS the Authority is contracting with the Contractor for the provision of certain goods and services described below for the term specified herein.

NOW THEREFORE, the parties agree as follows:

1. **DESCRIPTION OF GOODS AND SERVICES:** The Contractor shall provide the goods and services to the Authority in such quantities as the Authority requires for _____, as described in the Request for Bid dated March 2022.
2. **COSTS:** The Authority shall pay the Contractor the prices as stipulated in the Bid Form hereto attached as full compensation relative to the Bid dated _____, a copy of which is attached and incorporated into this contract. The Contractor shall be paid for items of work as noted:

Lump Sum Work

Payment for Lump Sum work shall cover all work specified or shown in the Contract Documents and shall be compensation in full for furnishing all supervision, labor, equipment and materials to complete the work.

Once the work commences the Authority shall make Progress Payments to the Contractor on a monthly basis. The Contractor shall submit an Application for Payment for the period ending the 15th day of the month. Each Application for Payment must be submitted to Authority on or before the 20th day of each month in such form and manner, and with such supporting data and content as the Authority may require. Per Georgia Code Section 13-10-2, Authority will withhold a 10% retainage on each and every Application for Payment until such time as the value of the contract (including change orders) exceeds 50%; and as long as completion and progress of the work is acceptable to the Authority. If after reaching the 50% completion of the value of the contract, the Authority's representative has determined that the work is

Division 3

Contract Forms

Section 1: Agreement Form

unsatisfactory or has fallen behind schedule, then retainage will resume at the previous level of 10%. The Contractor may submit a request for release of retainage 30 days after the completion and final acceptance of the Project, and upon receipt of all necessary documentation including, but not limited to, a final affidavit and release of surety.

3. **TIME FOR COMPLETION OF PROJECT:** Contractor hereby agrees to commence work within fourteen (14) calendar days under this contract or on a date to be specified in the Notice to Proceed. The total time for the Contractor to complete this project shall not exceed thirty (30) calendar days. The Contractor and Authority recognize that time is of the essence in completing this work and that there are delays, expense and difficulties involved in resolving a dispute related to a loss suffered by the Authority if the Work is not completed on time. Accordingly, instead of requiring such proof, Authority and Contractor agree that as liquidated damages for delay (but not as a penalty), the Contractor shall pay to the Authority, as liquidated damages the amount of \$250 per calendar day for each and every day or part of a day thereafter that said work remains substantially incomplete.
4. **WARRANTY ON SERVICES RENDERED:** The Contractor warrants its workmanship to be free from defects for a period of two (2) years from the date of final acceptance. The Contractor further warrants that its workmanship will conform to all specifications and will perform as specified. Upon receipt of written notice of a defect in workmanship, the Contractor shall repair the defect in a timely manner at no expense to Authority.
5. **WARRANTY ON GOODS PROVIDED:** The Contractor warrants its goods for a period of two (2) years from the date of final acceptance. Furthermore, the Contractor warrants that goods ordered to specifications will conform thereto and to any drawings, samples, or other description furnished or adopted by Authority, and will be fit and sufficient for the purpose intended; and that all goods are merchantable, of good material and workmanship, and free from defect. Such warranties, together with the Contractor's service warranties and guarantees, if any, shall survive inspection, test, acceptance of, and payment for the goods and shall run to Authority, its successors, assigns, customers at any tier, and ultimate user and joint users. Notices of any defects or nonconformity shall be given by Authority to the Contractor within fifteen (15) months after acceptance by ultimate user; provided however that in the event the goods are designed by the Contractor, notice must be given within three (3) years after acceptance by ultimate user. The rights and

Division 3

Contract Forms

Section 1: Agreement Form

remedies of Authority concerning latent defects shall exist indefinitely and shall not be affected in any way by any terms and conditions of this Agreement, including this clause. Authority may, at its option, and in addition to other remedies available at law, either (i) return for credit, (ii) require prompt correction or replacement of the defective or nonconforming goods, or (iii) have the defective items corrected or replaced at the Contractor's expense and deduct the cost thereof from any monies due the Contractor. The return to the Contractor of any defective or nonconforming goods and delivery to Authority of any corrected or replaced goods shall be at the Contractor's expense. Goods required to be corrected or replaced shall be subject to the provision of this paragraph and the paragraph of this Agreement entitled "inspection" in the same manner and to the same extent as goods originally delivered under this Agreement. In addition to correcting or replacing any defective or nonconforming goods, the Contractor shall also reimburse Authority for all costs and expenses incurred by Authority in connection with inspection and discovery of the defects, identifying and correcting the cause of such defects and all other activities reasonably undertaken by Authority to obtain conforming goods or attempting to obtain from the ultimate user a waiver to permit the defective goods to be used with all or part of the defective conditions.

6. **INSPECTION:** The Authority shall have the right to inspect the goods supplied hereunder at any time during the manufacture or fabrication thereof at the Contractor's facilities or elsewhere. Such inspection may include, without limitation, raw materials, components, work in process, and completed products as well as drawings, specifications, and released data. Final inspection and acceptance shall be after delivery to the delivery point designated by the Authority. If any inspection or test is made by the Authority at the Contractor's facility or elsewhere, the Contractor shall provide reasonable facilities and assistance for the inspection personnel. The Authority may reject all goods supplied hereunder, which are found to be defective. Goods so rejected may be returned to the Contractor at the Contractor's expense. No inspection, examination or test, regardless of extensiveness or type, and no approval give in connection with any such inspection, examination or test, whether under this Agreement or another contract for the same or similar goods, shall relieve it, of any obligation to comply fully with all requirements of this Agreement, including the obligation to produce goods that conform to all requirements of the drawings, specifications and any other Contract Documents. At the Authority's request,

Division 3

Contract Forms

Section 1: Agreement Form

the Contractor shall repair or replace defective goods at the Contractor's expense. Failure to inspect goods, failure to discover defects in goods or payment for goods shall not constitute acceptance or limit any of the Authority's rights, including without limitation those under the WARRANTY provisions of this Agreement. In the event inspection reveals a defect or defects and schedule urgency requires that the defect or defects be corrected by the Authority to support production, all cost of such correction, including without limitation installation and removal, will be charged to the Contractor; such charges will also include time and material and appropriate indirect and overhead expenses. The Contractor shall maintain in inspection system acceptable to the Authority covering the goods furnished hereunder.

7. **CONTRACTOR'S AFFIDAVITS:** The Contractor shall issue a "Standard Contractor's Affidavit Interim Waiver and Release Upon Payment" and a "Standard Contractor's Affidavit Unconditional Waiver and Release upon Final Payment" provided by the Authority before receiving any interim or final payment for any services performed.
8. **ASSIGNMENT AND SUBCONTRACTING:** The Contractor shall not assign this Agreement or any portion of this Agreement, nor shall the Contractor subcontract for goods or completed or substantially completed services purchased hereunder without the prior express written consent of the Authority. No assignment or subcontract by the Contractor, including any assignment or subcontract to which the Authority consents, shall in any way relieve the Contractor from complete and punctual performance of this Agreement, including without limitation all of the Contractor's obligations under the WARRANTY provisions of this Agreement.
9. **THE AUTHORITY'S ASSISTANCE AND COOPERATION:** During the Contractor's performance of this Agreement, the Authority may, but has no obligation to, provide assistance to, or cooperate with, the Contractor in activities that facilitate the proper performance and completion of this Agreement by the Contractor. Such assistance and cooperation may include without limitation: (i) providing engineering or other analysis or advice on correcting problems; (ii) refraining from strict enforcement of time schedule requirements under this Agreement; (iii) permitting use of test materials or documentation not performed or produced under this Agreement. Such assistance or cooperation by the Authority shall not be construed, and the Contractor agrees that it will not claim that any such assistance or cooperation

Division 3

Contract Forms

Section 1: Agreement Form

operates, to relieve the Contractor from complete, proper and punctual performance of all the Contractor's obligations under this Agreement.

10. **WORK ON THE AUTHORITY'S DESIGNATED PREMISES:** In the event that the Contractor, the Contractor's employees or agents or the Contractor's subcontractors enter the Authority's designated premises for any reason in connection with this Agreement, the Contractor and such other parties shall observe all security requirements and all plant safety, plant protection, and traffic regulations. The Contractor shall defend, indemnify, and hold the Authority harmless from all claims, actions, demands, loss, and causes of action, arising from injury, including death, to any person, or damage to any property, when such injury or damage results in whole or in part from the acts or omissions of the Contractor, the Contractor's employees or agents or the Contractor's subcontractor, save and except damage caused by the sole negligence of the Authority. The Contractor, and any subcontractors used by the Contractor in connection with this Agreement, shall carry Workmen's Compensation and Employees' Liability Insurance to cover the Contractor's and any subcontractor's legal liability on account of accidents to their employees. The Contractor and any subcontractor shall carry adequate Comprehensive General Liability and adequate Comprehensive Automobile Liability Insurance covering accidents to their employees. The Contractor and any subcontractor shall carry adequate Comprehensive General Liability and adequate Comprehensive Automobile Liability Insurance covering legal liability of the Contractor and any subcontractor on account of accidents arising out of the operations of the Contractor or any subcontractor and resulting in bodily injury, including death, being sustained by any person or persons, or in any damage to property. At the Authority's request, the Contractor shall furnish to the Authority certificates from the Contractor's insurers showing such coverage in effect and agreeing to give the Authority thirty (30) days prior written notice of cancellation of the coverage.
11. **RISK MANAGEMENT REQUIREMENTS:** The Contractor shall abide by the Authority's applicable Risk Management Requirements, attached to this Agreement as Exhibit A and hereby incorporated into this Agreement.
12. **TERMINATION FOR DEFAULT:**
 - (a) The Authority may, subject to the provisions of subparagraph (c) below, by written notice of default to the Contractor, terminate the whole or any part of this Agreement in any one of the following circumstances; (i) if the Contractor fails to perform this Agreement

Division 3

Contract Forms

Section 1: Agreement Form

within the time specified herein or any extension thereof; or (ii) if the Contractor fails to perform any of the other provisions of this Agreement, or so fails to make progress as to endanger performance of this Agreement in accordance with its terms, and does not cure such failure within a period of ten (10) days or longer period (as the Authority may authorize in writing) after receipt of notice from the Authority specifying such failure.

- (b) In the event the Authority terminates this Agreement in whole or in part as provided in subparagraph (a) above, the Authority may procure, upon such terms and in such manner as the Authority may deem appropriate, services, similar to those so terminated, and the Contractor shall be liable to the Authority for any Excess costs for the same, including without limitation all cost and expenses of the type specified in the "WARRANTY" paragraph of this Agreement; provided, that the Contractor shall continue the performance of this Agreement to the extent not terminated hereunder.
- (c) Except with regard to defaults of subcontractors, the Contractor shall not be liable for any excess costs if the failure to perform this Agreement arises out of causes beyond the control and without the fault of negligence of the Contractor such causes may include, but are not limited to, acts of God, or of the public enemy, acts of the Government in either its sovereign or contractual capacity, fires, flood, epidemics, quarantine restrictions, strikes, freight embargoes, and unusually severe weather, but in every case the failure to perform must be beyond the control and without the fault or negligence of the Contractor. If the failure to perform is caused by the default of a subcontractor, and if such default arises out of causes beyond the control of both the Contractor and the subcontractor, and without the fault of negligence of either of them, the Contractor shall not be liable for any excess costs for failure to perform, unless the services to be furnished by the subcontractor were obtainable from other sources in sufficient time to permit the Contractor to meet the required delivery schedule. The term "subcontractor" shall mean subcontractor at any tier.
- (d) If, after notice of termination of this Agreement under the provisions of this paragraph, it is determined for any reason that the Contractor was not in default under the provisions above or that the default was

Division 3

Contract Forms

Section 1: Agreement Form

excusable under the provisions of this paragraph, the rights and obligations of the parties shall be the same as if the notice of termination has been issued pursuant to the "Termination for Convenience" paragraph of this Agreement.

- (e) The rights and remedies of the Authority provided in this paragraph shall not be exclusive and are in addition to any other rights and remedies provided by law or under this Agreement.

13. **TERMINATION FOR CONVENIENCE**: The Authority may at any time by written notice terminate all or any part of this Agreement for the Authority's convenience. If this Agreement is terminated, in whole or in part, for the Authority's convenience, the Contractor shall be paid an amount, to be mutually agreed upon, which shall be adequate to cover the actual and reasonable cost paid by the Contractor for the actual goods and labor reasonably used by the Contractor to perform the work under this Agreement to the effective date of termination, plus a reasonable profit thereon; provided that no amount shall be paid to the Contractor for (i) any anticipatory profits related to work under this Agreement not yet performed, or (ii) costs incurred due to the Contractor's failure to terminate work as ordered on the effective date of termination. In no event shall the total amount paid under the provisions of this paragraph exceed the prices set forth in this Agreement for the work terminated.
14. **DISPUTES**: Pending resolution of any dispute hereunder, the Contractor shall proceed diligently with the performance of work in accordance with the Authority's direction.
15. **NOTICES**: All notices required or permitted to be given hereunder shall be deemed to be properly given if delivered in writing personally or sent by United States certified or registered mail addressed to the Contractor or the Authority, as the case may be, with postage thereon fully prepaid. The effective time shall be at the time of mailing.
16. **ATTORNEYS' FEES**: The Contractor shall pay reasonable attorneys' fees to the Authority should the Authority be required to incur attorneys' fees in enforcing the provisions of this Agreement or in the collection of any monies herein required to be paid by the Contractor to the Authority.
17. **COUNTERPARTS AND ELECTRONIC SIGNATURES**: This Agreement may be executed in one or more counterparts, each of which will be deemed to be an original, but all of which together will constitute one and the same

Division 3

Contract Forms

Section 1: Agreement Form

instrument. An executed signature page delivered via facsimile transmission or electronic signature shall be deemed as effective as an original executed signature page.

IN WITNESS WHEREOF this _____ day of _____, 2022, said parties have hereunto set their seals the day and year above first written.

Executed on behalf of:

CLAYTON COUNTY WATER AUTHORITY

CONTRACTOR

By: _____
Name: _____
Title: General Manager

By: _____
Name: _____
Title: _____

Attest: _____
Name: _____
Title: _____
Date: _____

Attest: _____
Name: _____
Title: _____
Date: _____

[Corporate Seal]

[Corporate Seal]

Division 3

Contract Forms

Section 1: Agreement Form

RISK MANAGEMENT REQUIREMENTS

The Contractor will provide minimum insurance coverage and limits as per the following: The Contractor will file with the Authority Certificates of Insurance, certifying the required insurance coverage and stating that each policy has been endorsed to provide thirty (30) day notice to the Authority in the event that coverage is cancelled, non-renewed, or the types of coverage or limits of liability are reduced below those required. All bonds and insurance coverage must be placed with an insurance company approved by the Authority's Management, admitted to do business in the State of Georgia, and rated Secure ("B+" or better) by A.M. Best Company in the latest edition of Property and Casualty Ratings, or rated by Standard & Poors Insurance Ratings, latest edition as Secure ("BBB" or better). Worker's Compensation self-insurance for individual Contractors must be approved by the Worker's Compensation Board, State of Georgia and/or Self-Insurance pools approved by the Insurance Commissioner, State of Georgia.

CONTRACTS FOR UP TO \$50,000

Worker's Compensation – Worker's Compensation coverage on a statutory basis for the State of Georgia with an Employer's Liability limit of \$100,000 each Accident, Disease \$100,000 each employee, \$500,000 Disease policy limit.

Automobile Liability – Automobile liability coverage for owned, hired and non-owned vehicles in the amount of \$500,000 combined single limit.

Commercial General Liability – Coverage to be provided on "occurrence" not "claims made" basis. The coverage is to include Contractual liability, Per Project Limit of Liability, losses caused by Explosion, Collapse and Underground ("xcu") perils, the "Clayton County Water Authority" is to be added as an Additional Insured and Products and Completed Operations coverage is to be maintained for three (3) years following completion of work.

CONTRACTS FOR MORE THAN \$50,000

Worker's Compensation – Worker's Compensation coverage on a statutory basis for the State of Georgia with an Employer's Liability limit of \$1,000,000. The increased Employer's Liability limit may be provided by an Umbrella or Excess Liability policy.

Automobile Liability - Automobile liability coverage for owned, hired and non-owned vehicles in the amount of \$1,000,000 combined single limit.

Commercial General Liability – Coverage to be provided on "occurrence" not "claims made" basis. The coverage is to include Contractual liability, Per Project Limit of Liability, losses caused by Explosion, Collapse and Underground ("xcu") perils, the "Clayton County Water Authority" is to be added as an Additional Insured and Products and Completed Operations coverage is to be maintained for three (3) years following completion of work.

Division 3

Contract Forms

Section 1: Agreement Form

RISK MANAGEMENT REQUIREMENTS (Cont'd)

CONTRACTS FOR UP TO \$50,000

CONTRACTS FOR MORE THAN \$50,000

LIMITS OF LIABILITY:

\$1,000,000	Per Occurrence
\$1,000,000	Personal and Advertising
\$50,000	Fire Damage*
\$5,000	Medical Payments*
\$1,000,000	General Aggregate
\$1,000,000	Products/Completed Operations per Occurrence and Aggregate

**These are automatic minimums*

Owner's Protective Liability – The Authority's Management may, in its discretion, require Owner's Protective Liability in some situations.

Umbrella and/or Excess Liability – The umbrella or Excess Liability Policy may be used to combine with underlying policies to obtain the limits required. The Management of the Authority may elect to require higher limits.

Owner's Protective Liability – The Authority's Management may, in its discretion, require Owner's Protective Liability in some situations.

END OF SECTION

Division 3

Contract Forms

Section 2: Performance Bond

KNOW ALL MEN BY THESE PRESENTS THAT _____
_____ (as CONTRACTOR, hereinafter referred to as the
“Principal”), and _____ (as SURETY
COMPANY), hereinafter referred to as the “CONTRACTOR’S SURETY”), are held and
firmly bound unto the Clayton County Water Authority (as OWNER, hereinafter referred
to as “CCWA”), for the use and benefit of any “Claimant” as hereinafter defined in the sum
of _____ Dollars (\$_____)
lawful money of the United States of America, for the payment of which the Principal and
the Contractor’s Surety bind themselves, their heirs, executors, administrators,
successors and assigns, jointly and severally, firmly by these presents.

WHEREAS, the Principal has entered, or is about to enter, into a certain written
agreement with CCWA, dated _____, which is incorporated herein
by reference in its entirety (hereinafter referred to as the “CONTRACT”), for the
construction of a project known as **W.B. Casey WRRF Secondary Launder Covers**
(hereinafter referred to as “the PROJECT”).

NOW THEREFORE, the conditions of this obligation are as follows:

1. That if the Principal shall fully and completely perform each and all of the
terms, provisions and requirements of the Contract, including and during
the period of any warranties or guarantees required thereunder, and all
modifications, amendments, changes, deletions, additions, and alterations
thereto that may hereafter be made; and if the Principal and the Contractor’s
Surety shall indemnify and hold harmless CCWA from any and all losses,
liability and damages, claims, judgments, liens, costs and fees of every
description, including but not limited to, any damages for delay, which
CCWA may incur, sustain or suffer by reason of the failure or default on the
part of the Principal in the performance of any and all of the terms,
provisions and requirements of the Contract, including all modifications,
amendments, changes, deletions, additions, and alterations thereto and
any warranties or guarantees required thereunder, then this obligation shall
be void; otherwise to remain in full force and effect;
2. In the event of a failure of performance of the Contract by the Principal,
which shall include, but not be limited to, any breach of default of the
Contract;

Division 3

Contract Forms

Section 2: Performance Bond

- a. The Contractor’s Surety shall commence performance of its obligations and undertakings under this Bond no later than thirty (30) days after written notice from CCWA to the Contractor’s Surety;
- b. The means, method or procedure by which the Contractor’s Surety undertakes to perform its obligations under this Bond shall be subject to the advance written approval of CCWA.

The Contractor’s Surety hereby waives notice of any and all modifications, omissions, additions, changes and advance payments or deferred payments in or about the Contract and agrees that the obligations undertaken by this Bond shall not be impaired in any manner by reason of any such modifications, omissions, additions, changes, and advance payments or deferred payments. The Parties further expressly agree that any action on this Bond may be brought within the time allowed by Georgia law for suit on contracts under seal.

IN WITNESS WHEREOF, the principal and Contractor’s Surety have hereunto affixed their corporate seals and caused this obligation to be signed by their duly authorized officers or attorneys-in-fact, this _____ day of _____ 20__.

(Name of Principal)

(Name of Contractor’s Surety)

By: _____

By: _____

Name Printed: _____

Name Printed: _____

Title: _____

Title: _____

Attest: _____

Attest: _____

Name: _____

Name: _____

Date: _____

Date: _____

[Corporate Seal]

[Corporate Seal]

(ATTACH SURETY’S POWER OF ATTORNEY)

END OF SECTION

Division 3

Contract Forms

Section 3: Payment Bond

KNOW ALL MEN BY THESE PRESENTS THAT _____
_____ (as CONTRACTOR, hereinafter referred to as the “Principal”), and _____ (as SURETY COMPANY, hereinafter referred to as the “CONTRACTOR’S SURETY”), are held and firmly bound unto the Clayton County Water Authority (as OWNER, hereinafter referred to as “CCWA”), for the use and benefit of any “Claimant” as hereinafter defined in the sum of _____ Dollars (\$_____), lawful money of the United States of America, for the payment of which the Principal and the Contractor’s Surety bind themselves, their heirs, executors, administrators, successors and assigns, jointly and severally, firmly by these presents.

WHEREAS, the Principal has entered, or is about to enter, into a certain written agreement with CCWA, dated _____, which is incorporated herein by reference in its entirety (hereinafter referred to as the “CONTRACT”), for the construction of a project known as **W.B. Casey WRRF Secondary Launder Covers** (hereinafter referred to as “the PROJECT”).

NOW THEREFORE, the condition of this obligation is such, that if the Principal shall promptly make payment to any Claimant, as hereinafter defined, for all labor, services and materials used or reasonably required for use in the performance of the Contract, then this obligation shall be void; otherwise to remain in full force and effect.

A “Claimant” shall be defined herein as any subcontractor, person, party, partnership, corporation or other entity furnishing labor, services or materials used or reasonably required for use in the performance of the Contract, without regard to whether such labor, services or materials were sold, leased or rented, and without regard to whether such Claimant is or is not in privity of the Contract with the Principal or any subcontractor performing work on the Project.

In the event of any claim made by the Claimant against CCWA, or the filing of a Lien against the property of CCWA affected by the Contract, the Contractor’s Surety shall either settle or resolve the Claim and shall remove any such Lien by bond or otherwise as provided in the Contract.

The Parties further expressly agree that any action on this Bond may be brought within the time allowed by Georgia law for suit on contracts under seal.

Division 3

Contract Forms

Section 3: Payment Bond

IN WITNESS WHEREOF, the Principal and Contractor's Surety have hereunto affixed their corporate seals and caused this obligation to be signed by their duly authorized officers on this _____ day of _____ 20____.

(Name of Principal)

(Name of Contractor's Surety)

By: _____
Name _____
Printed: _____
Title: _____

By: _____
Name _____
Printed: _____
Title: _____

Attest: _____
Name: _____
Date: _____

Attest: _____
Name: _____
Date: _____

[Corporate Seal]

[Corporate Seal]

(ATTACH SURETY'S POWER OF ATTORNEY)

END OF SECTION

Division 3

Contract Forms

Section 4: Non-Collusion Certificate

STATE OF _____, COUNTY OF _____

Personally appeared before the undersigned officer duly authorized by law to administer oaths

who, after being first duly sworn, depose and say that they are all the officers, agents, persons or employees who have acted for or represented _____

_____, and that said

in proposing or procuring the Contract with the Clayton County Water Authority on the following project: **W.B. Casey WRRF Secondary Launder Covers**

has not by (himself, themselves) or through any persons, officers, agents or employees prevented or attempted to prevent by any means whatsoever competition in such bidding; or by any means whatsoever prevented or endeavored to prevent anyone from making a proposal therefore or induced or attempted to induce another to withdraw a bid for said work.

ATTEST:

By: _____
Bidder

By: _____
Name

By: _____
Name

Title: _____

Title: _____

Sworn to and subscribed before me this _____ day of _____, 20____

Notary Public: _____ My Commission expires: _____

END OF SECTION

Division 3

Contract Forms

Section 5: Certification of Absence of Conflict of Interest for Development of Specifications or Scope of Work

Required for each contract or arrangement to prepare or develop specifications or requirements (O.C.G.A. § 36-80-28)

The undersigned Contractor (Consultant), who is entering into a contract or arrangement with the Clayton County Water Authority (CCWA) to prepare or develop specifications or requests for bids, requests for proposals, purchase order, or any other type of solicitation for CCWA, by signing below acknowledges and certifies to follow the requirements below:

- (1) Consultant shall avoid any appearance of impropriety and shall follow all of CCWA’s policies and procedures related to the project.
- (2) Consultant shall immediately disclose to CCWA any material transaction or relationship, including, but not limited to the Consultant, Consultant’s employees, agents or subsidiaries, that reasonably could be expected to give rise to a conflict of interest, including, but not limited to, past, present, during the pendency of the contract or arrangement, or known prospective engagements, involvement in litigation or other dispute, client relationships, or other business or financial interest.
- (3) Consultant acknowledges that any violation or threatened violation of the agreement may cause irreparable injury to CCWA entitling CCWA to seek injunctive relief in addition to all other legal remedies.

Any person may bring an action to declare null and void any purchase in violation of this Code section or to seek injunctive relief and damages against a person who makes any type of solicitation in violation of this Code section.

DISCLOSURES (Write “N/A” if Non-Applicable): _____

Name of Contractor

Name of Contractor’s Authorized Official

Signature of Contractor’s Authorized Official

Date

END OF SECTION

Division 4

Specifications

Section 1: General Requirements

1.1 General

- A. This Section describes how work is to be assigned and the basis that will be used for processing applications for payment. These provisions will apply to all work of the Contract Documents in addition to specific instructions provided within the individual specification sections.
- B. The basis for payment will be the bid unit prices and/or lump sum amounts included in the Pay Item Schedule and the actual quantities of work completed by the Contractor and approved by the CCWA. The CCWA reserves the right to adjust the quantities up or down as necessary to address needs.
- C. Nothing in this Section shall be construed as providing for additional payment beyond the Work Items. No payment will be made for partially completed Work Items. No payment will be made for the completion of excessive quantities of a Work Item as determined by the CCWA.

1.2 Work Items and Measurement

The following descriptions explain the work that is to be completed as part of each Work Item. The Contractor shall provide all labor, equipment, tools, and materials (unless indicated otherwise) to complete the Work Items in accordance with the Contract Documents. The following Work Items correspond to the Work Items listed on the "Pay Item Schedule" of the Bid Form.

Work Item 1. Mobilization: Defined as the Contractor's administrative and preparatory operations necessary including all labor, materials, equipment, maintenance, and other included costs which are necessary to initiate the work within 14 days of issuance of a Notice to Proceed. Mobilization shall not exceed 5% of the total bid amount.

Work Item 2. Installation of Launder Covers for One (1) Secondary Basin: Defined as Contractor providing all labor, materials and equipment for installation of launder covers for the entire circumference of the clarifier. Basin is 160' Diameter. Installation shall include all required supports, anchors, guardrails, gaskets, hardware, brackets fasteners and panels to complete the work. debris from site. The Work Item will be paid on a lump sum cost in accordance with Pay Item Schedule and as accepted/approved by CCWA.

Division 4

Specifications

Section 1: General Requirements

Work Item 3. Site Clean Up and Demobilization: Defined as Contractor providing all labor, materials and equipment for and any incidental cost which are necessary to complete site clean-up, restoration and demobilization activities. The Work Item will be paid on a lump sum cost in accordance with Pay Item Schedule and as accepted/approved by CCWA.

Work Item 4. Unforeseen Existing Conditions Allowance: The Contractor shall provide additional services only as directed and approved in writing by CCWA as may be required for the Project. This Work Item will only be used when unexpected conditions arise as determined by the CCWA. Payment shall be for all labor, equipment, materials, and incidental costs which are necessary to complete the work.

END OF SECTION

Division 4

Specifications

Section 2: Summary of Work

2.1 Project Location

The basin is located at the W.B Casey Water Resource and Recovery Facility (WRRF), at 688 Flint River Road, Jonesboro, GA. 30238.

2.2 Work Description

- A. W.B. Casey WRRF has Four (4) Secondary Basins, however, only one (1) W.B. Casey WRRF secondary basin will be part of this project; each secondary basin is approximately 161'-0" outside diameter inside edge of outer launder wall (see attachments). Cover installation shall be located around the entire circumference of the clarifier. Installation shall include all required supports, anchors, guardrails, gaskets, hardware, brackets, fasteners and panels to complete the work.
- B. Only one basin will be serviced at this time. Total of project should not exceed thirty (30) calendar days. Contractor is responsible for mobilization/demobilization, shipment of delivered material. Contractor is responsible for removal of trash and debris and leaving the site in a clean condition.
- C. The Clayton County Water Authority (CCWA) will drain the basin and removal of all algae and scum prior to installation, including hose washing the walls and floors of the basin. CCWA will ensure that water is not entering the basin and the entire work area is dry. Once the work is complete CCWA will refill the basin.
- D. The launder covers should inhibit algae growth, operate 24 hours a day, 7 days a week, reduce manpower, contain odors, and be corrosion and maintenance free. The cover system should be surface mounted to the outside perimeter concrete tank wall with anchors, fasteners, brackets for installation and support. Launder covers shall be designed to open away from the operator and toward the center of the tank or back toward the operator and outside of the tank. The launder covers must have an unobstructed access to the troughs, weir plates and the space between the weir plate and the sum baffle for necessary inspection and cleaning.
- E. The Contractor shall provide all supervision, labor, equipment, materials and miscellaneous items to complete the work.

Division 4

Specifications

Section 2: Summary of Work

- F. Contractor shall have a least one (1) representative/technician on site for complete installation, mobilization and demobilization. Work on plant premises shall be allowed Monday through Friday (Saturday and Sunday by permission only) from 7:00 am to 7:00 pm.
- G. An allowance of the basin should be added to the bid for any unforeseen issues that may arise. CCWA is not aware of any issues at this time.
- H. CCWA or its representative will inspect the basin to determine if any additional repairs are necessary and authorize the Contractor to proceed with such repairs.
- I. The basins will be inspected jointly throughout the project by CCWA or its representatives, and the Contractor.
- J. All work described above must be performed as specified.

2.3 Special Requirements

- A. Only one (1) Basin can be out-of-service at a time. The Contractor shall conduct work in a manner to cause no delay in plant operations and shall coordinate with CCWA personnel for taking Basins out-of-service, and for putting completed Basins back into service.
- B. Isolation and draining of the Basin will be required to complete the work and shall be completed by CCWA personnel with coordination from the Contractor.
- C. Contractor shall not obstruct access to the other 3 Basins that are not being worked on.
- D. Contractor will conduct a progress meeting to discuss safety concerns, current work activities, proposed work activities and updates to completion schedule.

2.4 Acceptance

- A. A CCWA Inspector shall inspect all components of the Project for compliance with the Contract Documents. The Contractor shall, at all times, permit and facilitate inspection of work by the CCWA. The presence of a CCWA

Division 4

Specifications

Section 2: Summary of Work

Inspector or CCWA Engineer on the site of work shall not be construed to, in any manner, relieve the Contractor of their responsibility for strict compliance with the Contract Documents. The CCWA Inspector shall inform the Contractor when construction is deficient from the Contract Document and/or Construction Plan. Deficiencies shall be addressed in a timely manner as determined by the CCWA Inspector.

- B. Upon completion of the work, representative shall perform an on-site inspection and verify that all installation and material requirements have been met. Results of the inspection shall be made in writing to the CCWA.
- C. Final acceptance of the Project by the CCWA shall be when the Contractor has met all terms and conditions as set forth by the Contract Document. The date of Final Acceptance shall be no later than the date the CCWA approves the Contractor's final request for payment to release retainage. Final acceptance shall be written, signed and dated by the CCWA Engineer.
- D. The Contractor shall warrant work required by the Contract Documents for the Project and hold the CCWA harmless against all costs, expenses and losses, including, without limitation, incidental and consequential damages, resulting from any defects including without limitation, defects in material supplied by the Contractor and workmanship by the Contractor, which are discovered or arise within a period of two (2) years beginning on the date of final acceptance by the CCWA.

END OF SECTION

DRAWINGS

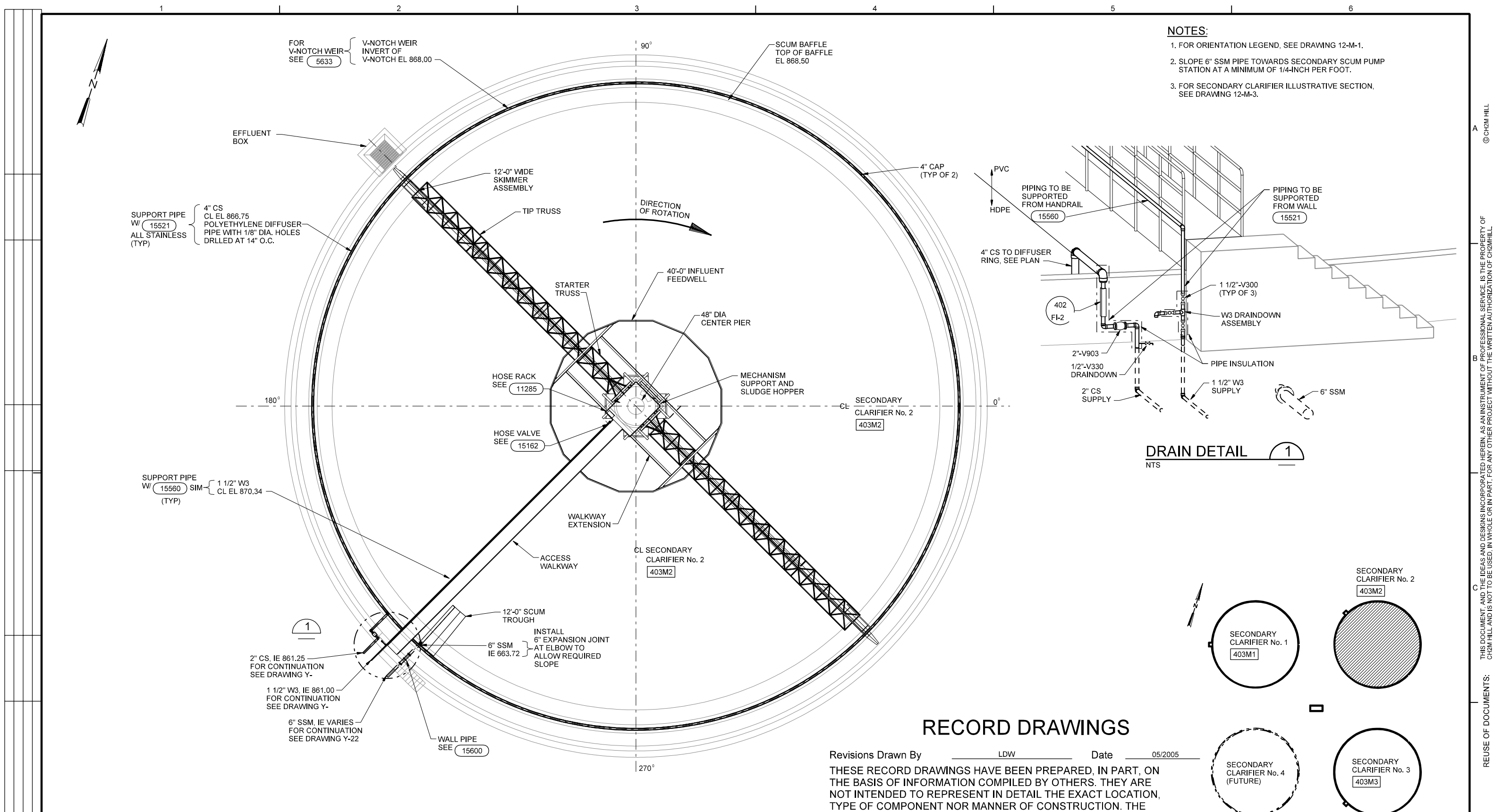

RECORD DRAWINGS

Revisions Drawn By LDW Date 05/2005

THESE RECORD DRAWINGS HAVE BEEN PREPARED, IN PART, ON THE BASIS OF INFORMATION COMPILED BY OTHERS. THEY ARE NOT INTENDED TO REPRESENT IN DETAIL THE EXACT LOCATION, TYPE OF COMPONENT NOR MANNER OF CONSTRUCTION. THE ENGINEER WILL NOT BE RESPONSIBLE FOR ANY ERRORS OR OMISSIONS WHICH HAVE BEEN INCORPORATED INTO THE RECORD DRAWINGS.

950719507020b.dgn	1-59, 61-63
95071950714m01d.dgn	1-63
95071950714m01d.dgn	1-63
95071950714m01d.dgn	1-63

DSGN D. DAUGHERTY DR 950714m01d.dgn R. SCHOL CHK M. MOORE APVD	NO. _____ DATE 05/2005	REVISION RECORD DRAWING	BY APVD	VERIFY SCALE BAR IS ONE INCH ON ORIGINAL DRAWING. 0" = 1" IF NOT ONE INCH ON THIS SHEET, ADJUST SCALES ACCORDINGLY.	CH2MHILL	CLAYTON COUNTY WATER AUTHORITY W.B. CASEY WATER RECLAMATION FACILITY EXPANSION AND UPGRADE PROJECT CLAYTON COUNTY, GEORGIA	SECONDARY CLARIFICATION MECHANICAL SECONDARY CLARIFIER No. 2 UPPER PLAN	DWG 12-M-2 DATE MAY 2005 PROJ 161430.CD
---	------------------------------	----------------------------	------------	--	-----------------	---	---	--

THIS DOCUMENT AND THE IDEAS AND DESIGNS INCORPORATED HEREIN, AS AN INSTRUMENT OF PROFESSIONAL SERVICE, IS THE PROPERTY OF CH2M HILL AND IS NOT TO BE USED, IN WHOLE OR IN PART, FOR ANY OTHER PROJECT WITHOUT THE WRITTEN AUTHORIZATION OF CH2M HILL.
 REUSE OF DOCUMENTS:
 RECORD DRAWING

ORIENTATION LEGEND						
CLARIFIER No.	ACCESS WALKWAY	48" ML	36" SE	18" RAS/WAS	6" SSM	DIRECTION OF ROTATION
1	315°	315°	180°	0°	315°	CW
2	225°	225°	135°	180°	225°	CW
3	135°	135°	225°	180°	135°	CW
4 (FUTURE)	45°	45°	270°	0°	45°	CW

NOTES:
 1. FOR SECONDARY CLARIFIER ILLUSTRATIVE SECTION, SEE DRAWING 12-M-3.

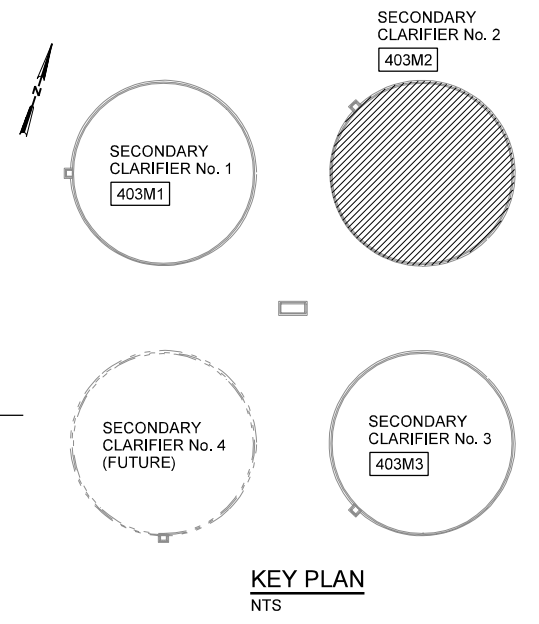
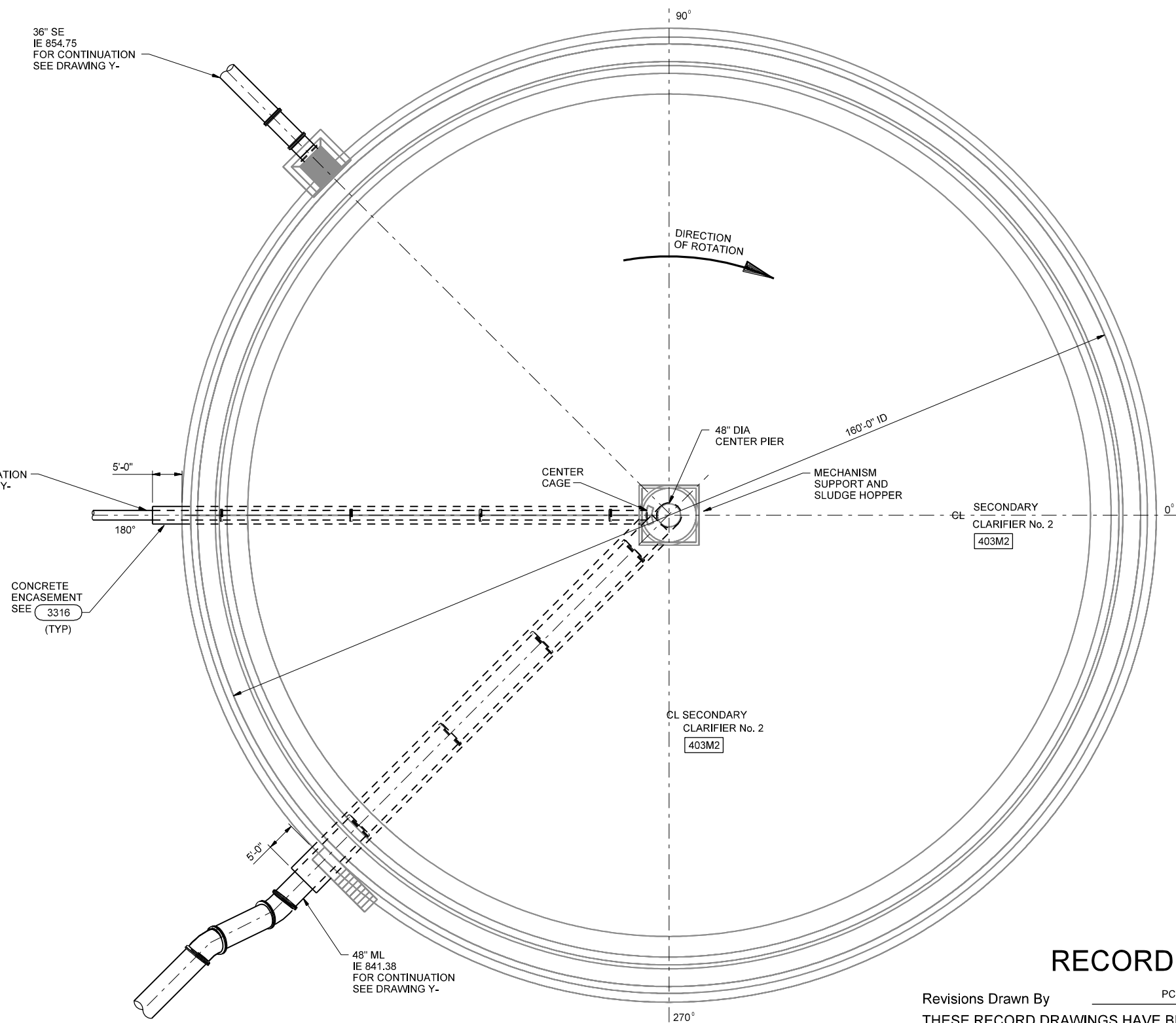

RECORD DRAWINGS

Revisions Drawn By PCR Date 05/2005
 THESE RECORD DRAWINGS HAVE BEEN PREPARED, IN PART, ON THE BASIS OF INFORMATION COMPILED BY OTHERS. THEY ARE NOT INTENDED TO REPRESENT IN DETAIL THE EXACT LOCATION, TYPE OF COMPONENT NOR MANNER OF CONSTRUCTION. THE ENGINEER WILL NOT BE RESPONSIBLE FOR ANY ERRORS OR OMISSIONS WHICH HAVE BEEN INCORPORATED INTO THE RECORD DRAWINGS.

PLAN
 3/32" = 1'-0"

9507950700.dgn 1-59, 61-63
 9507950714m01d.dgn 1-63
 9507950714m01m.dgn 1-63
 9507950714m01s.dgn 1-63

DSGN D. DAUGHERTY 950714m01d.dgn R. SCHOL	NO.	DATE 05/2005	REVISION RECORD DRAWING	BY	APVD	VERIFY SCALE BAR IS ONE INCH ON ORIGINAL DRAWING. 0 = 1" IF NOT ONE INCH ON THIS SHEET, ADJUST SCALES ACCORDINGLY.	CH2MHILL	CLAYTON COUNTY WATER AUTHORITY W.B. CASEY WATER RECLAMATION FACILITY EXPANSION AND UPGRADE PROJECT CLAYTON COUNTY, GEORGIA	SECONDARY CLARIFICATION MECHANICAL SECONDARY CLARIFIER No. 2 LOWER PLAN	DWG 12-M-1
CHK M. MOORE									DATE MAY 2005	
APVD									PROJ 161430.CD	

REUSE OF DOCUMENTS: THIS DOCUMENT AND THE IDEAS AND DESIGNS INCORPORATED HEREIN, AS AN INSTRUMENT OF PROFESSIONAL SERVICE, IS THE PROPERTY OF CH2M HILL AND IS NOT TO BE USED, IN WHOLE OR IN PART, FOR ANY OTHER PROJECT WITHOUT THE WRITTEN AUTHORIZATION OF CH2M HILL.
 RECORD DRAWING

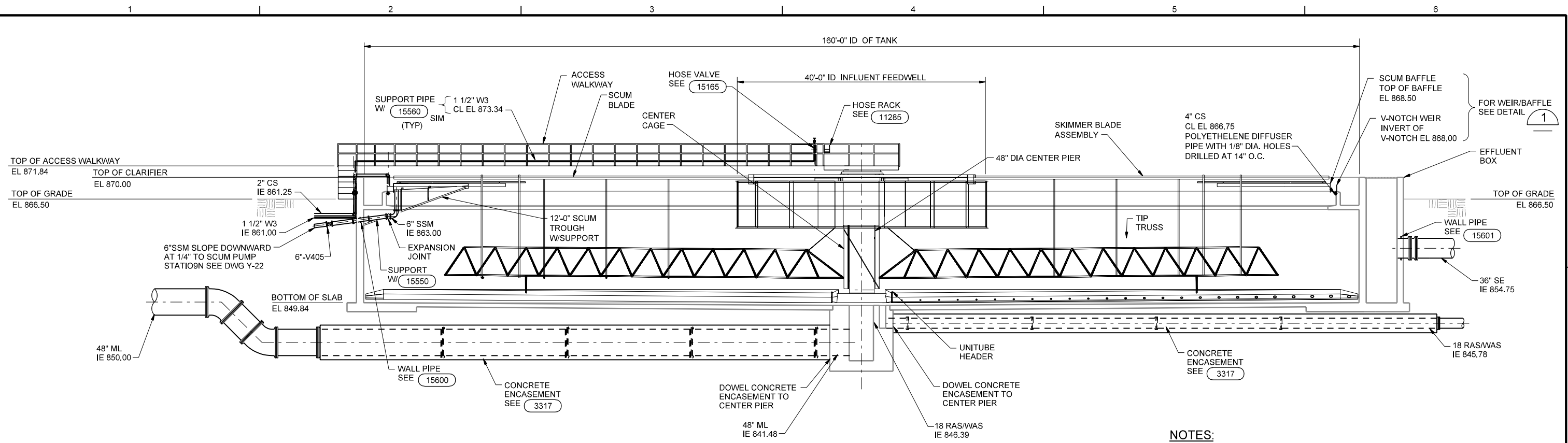

**SECONDARY CLARIFIER
ILLUSTRATIVE SECTION**
NTS

NOTES:
1. FOR CLARIFIERS AND PIPING ORIENTATION LEGEND, SEE DRAWING 12-M-1.

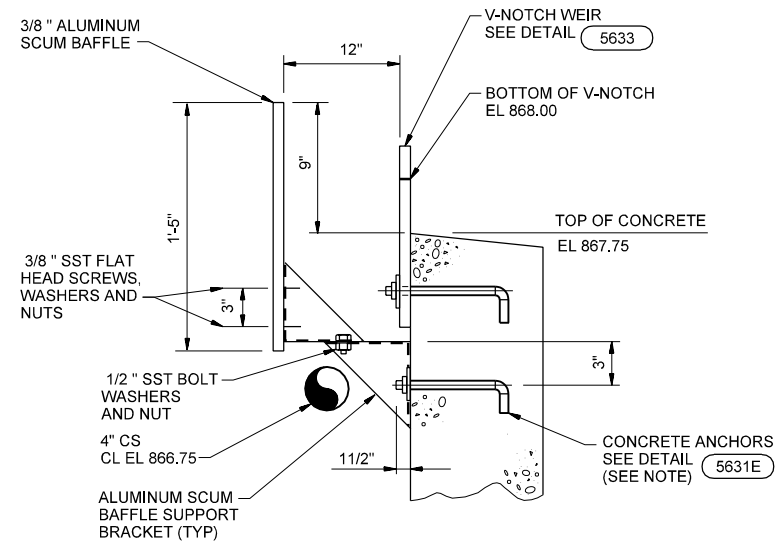

NOTE: MAXIMUM SCUM BAFFLE SUPPORT SPACING 4'-0" O.C.

WEIR/BAFFLE DETAIL
NTS

RECORD DRAWINGS

Revisions Drawn By LDW Date 05/2005

THESE RECORD DRAWINGS HAVE BEEN PREPARED, IN PART, ON THE BASIS OF INFORMATION COMPILED BY OTHERS. THEY ARE NOT INTENDED TO REPRESENT IN DETAIL THE EXACT LOCATION, TYPE OF COMPONENT NOR MANNER OF CONSTRUCTION. THE ENGINEER WILL NOT BE RESPONSIBLE FOR ANY ERRORS OR OMISSIONS WHICH HAVE BEEN INCORPORATED INTO THE RECORD DRAWINGS.

1-59, 61-63
1-63
1-63
1-63

DSGN D. DAUGHERTY DR 950714m01d.dgn R. SCHOL	NO.	DATE 05/2005	REVISION	BY	APVD	VERIFY SCALE BAR IS ONE INCH ON ORIGINAL DRAWING. 0 1" IF NOT ONE INCH ON THIS SHEET, ADJUST SCALES ACCORDINGLY.	CH2MHILL	CLAYTON COUNTY WATER AUTHORITY W.B. CASEY WATER RECLAMATION FACILITY EXPANSION AND UPGRADE PROJECT CLAYTON COUNTY, GEORGIA	SECONDARY CLARIFICATION MECHANICAL SECONDARY CLARIFIERS SECTION AND DETAIL	DWG 12-M-3 DATE MAY 2005 PROJ 161430.CD
--	-----	-----------------	----------	----	------	---	-----------------	---	---	--

REUSE OF DOCUMENTS: THIS DOCUMENT AND THE IDEAS AND DESIGNS INCORPORATED HEREIN, AS AN INSTRUMENT OF PROFESSIONAL SERVICE, IS THE PROPERTY OF CH2M HILL AND IS NOT TO BE USED, IN WHOLE OR IN PART, FOR ANY OTHER PROJECT WITHOUT THE WRITTEN AUTHORIZATION OF CH2M HILL. © CH2M HILL

W-9 Form

Request for Taxpayer Identification Number and Certification

Give Form to the
requester. Do not
send to the IRS.

▶ Go to www.irs.gov/FormW9 for instructions and the latest information.

Print or type. See Specific Instructions on page 3.	1 Name (as shown on your income tax return). Name is required on this line; do not leave this line blank.					
	2 Business name/disregarded entity name, if different from above					
	3 Check appropriate box for federal tax classification of the person whose name is entered on line 1. Check only one of the following seven boxes.	4 Exemptions (codes apply only to certain entities, not individuals; see instructions on page 3):				
	<input type="checkbox"/> Individual/sole proprietor or single-member LLC	<input type="checkbox"/> C Corporation	<input type="checkbox"/> S Corporation	<input type="checkbox"/> Partnership	<input type="checkbox"/> Trust/estate	Exempt payee code (if any) _____
	<input type="checkbox"/> Limited liability company. Enter the tax classification (C=C corporation, S=S corporation, P=Partnership) ▶ _____	Note: Check the appropriate box in the line above for the tax classification of the single-member owner. Do not check LLC if the LLC is classified as a single-member LLC that is disregarded from the owner unless the owner of the LLC is another LLC that is not disregarded from the owner for U.S. federal tax purposes. Otherwise, a single-member LLC that is disregarded from the owner should check the appropriate box for the tax classification of its owner.				
	<input type="checkbox"/> Other (see instructions) ▶ _____	(Applies to accounts maintained outside the U.S.)				
	5 Address (number, street, and apt. or suite no.) See instructions.	Requester's name and address (optional)				
6 City, state, and ZIP code						
7 List account number(s) here (optional)						

Part I Taxpayer Identification Number (TIN)

Enter your TIN in the appropriate box. The TIN provided must match the name given on line 1 to avoid backup withholding. For individuals, this is generally your social security number (SSN). However, for a resident alien, sole proprietor, or disregarded entity, see the instructions for Part I, later. For other entities, it is your employer identification number (EIN). If you do not have a number, see *How to get a TIN*, later.

Note: If the account is in more than one name, see the instructions for line 1. Also see *What Name and Number To Give the Requester* for guidelines on whose number to enter.

Social security number									
				-			-		
or									
Employer identification number									

Part II Certification

Under penalties of perjury, I certify that:

1. The number shown on this form is my correct taxpayer identification number (or I am waiting for a number to be issued to me); and
2. I am not subject to backup withholding because: (a) I am exempt from backup withholding, or (b) I have not been notified by the Internal Revenue Service (IRS) that I am subject to backup withholding as a result of a failure to report all interest or dividends, or (c) the IRS has notified me that I am no longer subject to backup withholding; and
3. I am a U.S. citizen or other U.S. person (defined below); and
4. The FATCA code(s) entered on this form (if any) indicating that I am exempt from FATCA reporting is correct.

Certification instructions. You must cross out item 2 above if you have been notified by the IRS that you are currently subject to backup withholding because you have failed to report all interest and dividends on your tax return. For real estate transactions, item 2 does not apply. For mortgage interest paid, acquisition or abandonment of secured property, cancellation of debt, contributions to an individual retirement arrangement (IRA), and generally, payments other than interest and dividends, you are not required to sign the certification, but you must provide your correct TIN. See the instructions for Part II, later.

Sign Here	Signature of U.S. person ▶	Date ▶

General Instructions

Section references are to the Internal Revenue Code unless otherwise noted.

Future developments. For the latest information about developments related to Form W-9 and its instructions, such as legislation enacted after they were published, go to www.irs.gov/FormW9.

Purpose of Form

An individual or entity (Form W-9 requester) who is required to file an information return with the IRS must obtain your correct taxpayer identification number (TIN) which may be your social security number (SSN), individual taxpayer identification number (ITIN), adoption taxpayer identification number (ATIN), or employer identification number (EIN), to report on an information return the amount paid to you, or other amount reportable on an information return. Examples of information returns include, but are not limited to, the following.

- Form 1099-INT (interest earned or paid)

- Form 1099-DIV (dividends, including those from stocks or mutual funds)
- Form 1099-MISC (various types of income, prizes, awards, or gross proceeds)
- Form 1099-B (stock or mutual fund sales and certain other transactions by brokers)
- Form 1099-S (proceeds from real estate transactions)
- Form 1099-K (merchant card and third party network transactions)
- Form 1098 (home mortgage interest), 1098-E (student loan interest), 1098-T (tuition)
- Form 1099-C (canceled debt)
- Form 1099-A (acquisition or abandonment of secured property)

Use Form W-9 only if you are a U.S. person (including a resident alien), to provide your correct TIN.

If you do not return Form W-9 to the requester with a TIN, you might be subject to backup withholding. See What is backup withholding, later.

By signing the filled-out form, you:

1. Certify that the TIN you are giving is correct (or you are waiting for a number to be issued),
2. Certify that you are not subject to backup withholding, or
3. Claim exemption from backup withholding if you are a U.S. exempt payee. If applicable, you are also certifying that as a U.S. person, your allocable share of any partnership income from a U.S. trade or business is not subject to the withholding tax on foreign partners' share of effectively connected income, and
4. Certify that FATCA code(s) entered on this form (if any) indicating that you are exempt from the FATCA reporting, is correct. See *What is FATCA reporting*, later, for further information.

Note: If you are a U.S. person and a requester gives you a form other than Form W-9 to request your TIN, you must use the requester's form if it is substantially similar to this Form W-9.

Definition of a U.S. person. For federal tax purposes, you are considered a U.S. person if you are:

- An individual who is a U.S. citizen or U.S. resident alien;
- A partnership, corporation, company, or association created or organized in the United States or under the laws of the United States;
- An estate (other than a foreign estate); or
- A domestic trust (as defined in Regulations section 301.7701-7).

Special rules for partnerships. Partnerships that conduct a trade or business in the United States are generally required to pay a withholding tax under section 1446 on any foreign partners' share of effectively connected taxable income from such business. Further, in certain cases where a Form W-9 has not been received, the rules under section 1446 require a partnership to presume that a partner is a foreign person, and pay the section 1446 withholding tax. Therefore, if you are a U.S. person that is a partner in a partnership conducting a trade or business in the United States, provide Form W-9 to the partnership to establish your U.S. status and avoid section 1446 withholding on your share of partnership income.

In the cases below, the following person must give Form W-9 to the partnership for purposes of establishing its U.S. status and avoiding withholding on its allocable share of net income from the partnership conducting a trade or business in the United States.

- In the case of a disregarded entity with a U.S. owner, the U.S. owner of the disregarded entity and not the entity;
- In the case of a grantor trust with a U.S. grantor or other U.S. owner, generally, the U.S. grantor or other U.S. owner of the grantor trust and not the trust; and
- In the case of a U.S. trust (other than a grantor trust), the U.S. trust (other than a grantor trust) and not the beneficiaries of the trust.

Foreign person. If you are a foreign person or the U.S. branch of a foreign bank that has elected to be treated as a U.S. person, do not use Form W-9. Instead, use the appropriate Form W-8 or Form 8233 (see Pub. 515, *Withholding of Tax on Nonresident Aliens and Foreign Entities*).

Nonresident alien who becomes a resident alien. Generally, only a nonresident alien individual may use the terms of a tax treaty to reduce or eliminate U.S. tax on certain types of income. However, most tax treaties contain a provision known as a "saving clause." Exceptions specified in the saving clause may permit an exemption from tax to continue for certain types of income even after the payee has otherwise become a U.S. resident alien for tax purposes.

If you are a U.S. resident alien who is relying on an exception contained in the saving clause of a tax treaty to claim an exemption from U.S. tax on certain types of income, you must attach a statement to Form W-9 that specifies the following five items.

1. The treaty country. Generally, this must be the same treaty under which you claimed exemption from tax as a nonresident alien.
2. The treaty article addressing the income.
3. The article number (or location) in the tax treaty that contains the saving clause and its exceptions.
4. The type and amount of income that qualifies for the exemption from tax.
5. Sufficient facts to justify the exemption from tax under the terms of the treaty article.

Example. Article 20 of the U.S.-China income tax treaty allows an exemption from tax for scholarship income received by a Chinese student temporarily present in the United States. Under U.S. law, this student will become a resident alien for tax purposes if his or her stay in the United States exceeds 5 calendar years. However, paragraph 2 of the first Protocol to the U.S.-China treaty (dated April 30, 1984) allows the provisions of Article 20 to continue to apply even after the Chinese student becomes a resident alien of the United States. A Chinese student who qualifies for this exception (under paragraph 2 of the first protocol) and is relying on this exception to claim an exemption from tax on his or her scholarship or fellowship income would attach to Form W-9 a statement that includes the information described above to support that exemption.

If you are a nonresident alien or a foreign entity, give the requester the appropriate completed Form W-8 or Form 8233.

Backup Withholding

What is backup withholding? Persons making certain payments to you must under certain conditions withhold and pay to the IRS 24% of such payments. This is called "backup withholding." Payments that may be subject to backup withholding include interest, tax-exempt interest, dividends, broker and barter exchange transactions, rents, royalties, nonemployee pay, payments made in settlement of payment card and third party network transactions, and certain payments from fishing boat operators. Real estate transactions are not subject to backup withholding.

You will not be subject to backup withholding on payments you receive if you give the requester your correct TIN, make the proper certifications, and report all your taxable interest and dividends on your tax return.

Payments you receive will be subject to backup withholding if:

1. You do not furnish your TIN to the requester,
2. You do not certify your TIN when required (see the instructions for Part II for details),
3. The IRS tells the requester that you furnished an incorrect TIN,
4. The IRS tells you that you are subject to backup withholding because you did not report all your interest and dividends on your tax return (for reportable interest and dividends only), or
5. You do not certify to the requester that you are not subject to backup withholding under 4 above (for reportable interest and dividend accounts opened after 1983 only).

Certain payees and payments are exempt from backup withholding. See *Exempt payee code*, later, and the separate Instructions for the Requester of Form W-9 for more information.

Also see *Special rules for partnerships*, earlier.

What is FATCA Reporting?

The Foreign Account Tax Compliance Act (FATCA) requires a participating foreign financial institution to report all United States account holders that are specified United States persons. Certain payees are exempt from FATCA reporting. See *Exemption from FATCA reporting code*, later, and the Instructions for the Requester of Form W-9 for more information.

Updating Your Information

You must provide updated information to any person to whom you claimed to be an exempt payee if you are no longer an exempt payee and anticipate receiving reportable payments in the future from this person. For example, you may need to provide updated information if you are a C corporation that elects to be an S corporation, or if you no longer are tax exempt. In addition, you must furnish a new Form W-9 if the name or TIN changes for the account; for example, if the grantor of a grantor trust dies.

Penalties

Failure to furnish TIN. If you fail to furnish your correct TIN to a requester, you are subject to a penalty of \$50 for each such failure unless your failure is due to reasonable cause and not to willful neglect.

Civil penalty for false information with respect to withholding. If you make a false statement with no reasonable basis that results in no backup withholding, you are subject to a \$500 penalty.

Criminal penalty for falsifying information. Willfully falsifying certifications or affirmations may subject you to criminal penalties including fines and/or imprisonment.

Misuse of TINs. If the requester discloses or uses TINs in violation of federal law, the requester may be subject to civil and criminal penalties.

Specific Instructions

Line 1

You must enter one of the following on this line; **do not** leave this line blank. The name should match the name on your tax return.

If this Form W-9 is for a joint account (other than an account maintained by a foreign financial institution (FFI)), list first, and then circle, the name of the person or entity whose number you entered in Part I of Form W-9. If you are providing Form W-9 to an FFI to document a joint account, each holder of the account that is a U.S. person must provide a Form W-9.

a. **Individual.** Generally, enter the name shown on your tax return. If you have changed your last name without informing the Social Security Administration (SSA) of the name change, enter your first name, the last name as shown on your social security card, and your new last name.

Note: ITIN applicant: Enter your individual name as it was entered on your Form W-7 application, line 1a. This should also be the same as the name you entered on the Form 1040/1040A/1040EZ you filed with your application.

b. **Sole proprietor or single-member LLC.** Enter your individual name as shown on your 1040/1040A/1040EZ on line 1. You may enter your business, trade, or “doing business as” (DBA) name on line 2.

c. **Partnership, LLC that is not a single-member LLC, C corporation, or S corporation.** Enter the entity’s name as shown on the entity’s tax return on line 1 and any business, trade, or DBA name on line 2.

d. **Other entities.** Enter your name as shown on required U.S. federal tax documents on line 1. This name should match the name shown on the charter or other legal document creating the entity. You may enter any business, trade, or DBA name on line 2.

e. **Disregarded entity.** For U.S. federal tax purposes, an entity that is disregarded as an entity separate from its owner is treated as a “disregarded entity.” See Regulations section 301.7701-2(c)(2)(iii). Enter the owner’s name on line 1. The name of the entity entered on line 1 should never be a disregarded entity. The name on line 1 should be the name shown on the income tax return on which the income should be reported. For example, if a foreign LLC that is treated as a disregarded entity for U.S. federal tax purposes has a single owner that is a U.S. person, the U.S. owner’s name is required to be provided on line 1. If the direct owner of the entity is also a disregarded entity, enter the first owner that is not disregarded for federal tax purposes. Enter the disregarded entity’s name on line 2, “Business name/disregarded entity name.” If the owner of the disregarded entity is a foreign person, the owner must complete an appropriate Form W-8 instead of a Form W-9. This is the case even if the foreign person has a U.S. TIN.

Line 2

If you have a business name, trade name, DBA name, or disregarded entity name, you may enter it on line 2.

Line 3

Check the appropriate box on line 3 for the U.S. federal tax classification of the person whose name is entered on line 1. Check only one box on line 3.

IF the entity/person on line 1 is a(n) . . .	THEN check the box for . . .
• Corporation	Corporation
• Individual • Sole proprietorship, or • Single-member limited liability company (LLC) owned by an individual and disregarded for U.S. federal tax purposes.	Individual/sole proprietor or single-member LLC
• LLC treated as a partnership for U.S. federal tax purposes, • LLC that has filed Form 8832 or 2553 to be taxed as a corporation, or • LLC that is disregarded as an entity separate from its owner but the owner is another LLC that is not disregarded for U.S. federal tax purposes.	Limited liability company and enter the appropriate tax classification. (P= Partnership; C= C corporation; or S= S corporation)
• Partnership	Partnership
• Trust/estate	Trust/estate

Line 4, Exemptions

If you are exempt from backup withholding and/or FATCA reporting, enter in the appropriate space on line 4 any code(s) that may apply to you.

Exempt payee code.

- Generally, individuals (including sole proprietors) are not exempt from backup withholding.
- Except as provided below, corporations are exempt from backup withholding for certain payments, including interest and dividends.
- Corporations are not exempt from backup withholding for payments made in settlement of payment card or third party network transactions.
- Corporations are not exempt from backup withholding with respect to attorneys’ fees or gross proceeds paid to attorneys, and corporations that provide medical or health care services are not exempt with respect to payments reportable on Form 1099-MISC.

The following codes identify payees that are exempt from backup withholding. Enter the appropriate code in the space in line 4.

- 1—An organization exempt from tax under section 501(a), any IRA, or a custodial account under section 403(b)(7) if the account satisfies the requirements of section 401(f)(2)
- 2—The United States or any of its agencies or instrumentalities
- 3—A state, the District of Columbia, a U.S. commonwealth or possession, or any of their political subdivisions or instrumentalities
- 4—A foreign government or any of its political subdivisions, agencies, or instrumentalities
- 5—A corporation
- 6—A dealer in securities or commodities required to register in the United States, the District of Columbia, or a U.S. commonwealth or possession
- 7—A futures commission merchant registered with the Commodity Futures Trading Commission
- 8—A real estate investment trust
- 9—An entity registered at all times during the tax year under the Investment Company Act of 1940
- 10—A common trust fund operated by a bank under section 584(a)
- 11—A financial institution
- 12—A middleman known in the investment community as a nominee or custodian
- 13—A trust exempt from tax under section 664 or described in section 4947

The following chart shows types of payments that may be exempt from backup withholding. The chart applies to the exempt payees listed above, 1 through 13.

IF the payment is for . . .	THEN the payment is exempt for . . .
Interest and dividend payments	All exempt payees except for 7
Broker transactions	Exempt payees 1 through 4 and 6 through 11 and all C corporations. S corporations must not enter an exempt payee code because they are exempt only for sales of noncovered securities acquired prior to 2012.
Barter exchange transactions and patronage dividends	Exempt payees 1 through 4
Payments over \$600 required to be reported and direct sales over \$5,000 ¹	Generally, exempt payees 1 through 5 ²
Payments made in settlement of payment card or third party network transactions	Exempt payees 1 through 4

¹ See Form 1099-MISC, Miscellaneous Income, and its instructions.

² However, the following payments made to a corporation and reportable on Form 1099-MISC are not exempt from backup withholding: medical and health care payments, attorneys' fees, gross proceeds paid to an attorney reportable under section 6045(f), and payments for services paid by a federal executive agency.

Exemption from FATCA reporting code. The following codes identify payees that are exempt from reporting under FATCA. These codes apply to persons submitting this form for accounts maintained outside of the United States by certain foreign financial institutions. Therefore, if you are only submitting this form for an account you hold in the United States, you may leave this field blank. Consult with the person requesting this form if you are uncertain if the financial institution is subject to these requirements. A requester may indicate that a code is not required by providing you with a Form W-9 with "Not Applicable" (or any similar indication) written or printed on the line for a FATCA exemption code.

A—An organization exempt from tax under section 501(a) or any individual retirement plan as defined in section 7701(a)(37)

B—The United States or any of its agencies or instrumentalities

C—A state, the District of Columbia, a U.S. commonwealth or possession, or any of their political subdivisions or instrumentalities

D—A corporation the stock of which is regularly traded on one or more established securities markets, as described in Regulations section 1.1472-1(c)(1)(i)

E—A corporation that is a member of the same expanded affiliated group as a corporation described in Regulations section 1.1472-1(c)(1)(i)

F—A dealer in securities, commodities, or derivative financial instruments (including notional principal contracts, futures, forwards, and options) that is registered as such under the laws of the United States or any state

G—A real estate investment trust

H—A regulated investment company as defined in section 851 or an entity registered at all times during the tax year under the Investment Company Act of 1940

I—A common trust fund as defined in section 584(a)

J—A bank as defined in section 581

K—A broker

L—A trust exempt from tax under section 664 or described in section 4947(a)(1)

M—A tax exempt trust under a section 403(b) plan or section 457(g) plan

Note: You may wish to consult with the financial institution requesting this form to determine whether the FATCA code and/or exempt payee code should be completed.

Line 5

Enter your address (number, street, and apartment or suite number). This is where the requester of this Form W-9 will mail your information returns. If this address differs from the one the requester already has on file, write NEW at the top. If a new address is provided, there is still a chance the old address will be used until the payor changes your address in their records.

Line 6

Enter your city, state, and ZIP code.

Part I. Taxpayer Identification Number (TIN)

Enter your TIN in the appropriate box. If you are a resident alien and you do not have and are not eligible to get an SSN, your TIN is your IRS individual taxpayer identification number (ITIN). Enter it in the social security number box. If you do not have an ITIN, see *How to get a TIN* below.

If you are a sole proprietor and you have an EIN, you may enter either your SSN or EIN.

If you are a single-member LLC that is disregarded as an entity separate from its owner, enter the owner's SSN (or EIN, if the owner has one). Do not enter the disregarded entity's EIN. If the LLC is classified as a corporation or partnership, enter the entity's EIN.

Note: See *What Name and Number To Give the Requester*, later, for further clarification of name and TIN combinations.

How to get a TIN. If you do not have a TIN, apply for one immediately. To apply for an SSN, get Form SS-5, Application for a Social Security Card, from your local SSA office or get this form online at www.SSA.gov. You may also get this form by calling 1-800-772-1213. Use Form W-7, Application for IRS Individual Taxpayer Identification Number, to apply for an ITIN, or Form SS-4, Application for Employer Identification Number, to apply for an EIN. You can apply for an EIN online by accessing the IRS website at www.irs.gov/Businesses and clicking on Employer Identification Number (EIN) under Starting a Business. Go to www.irs.gov/Forms to view, download, or print Form W-7 and/or Form SS-4. Or, you can go to www.irs.gov/OrderForms to place an order and have Form W-7 and/or SS-4 mailed to you within 10 business days.

If you are asked to complete Form W-9 but do not have a TIN, apply for a TIN and write "Applied For" in the space for the TIN, sign and date the form, and give it to the requester. For interest and dividend payments, and certain payments made with respect to readily tradable instruments, generally you will have 60 days to get a TIN and give it to the requester before you are subject to backup withholding on payments. The 60-day rule does not apply to other types of payments. You will be subject to backup withholding on all such payments until you provide your TIN to the requester.

Note: Entering "Applied For" means that you have already applied for a TIN or that you intend to apply for one soon.

Caution: A disregarded U.S. entity that has a foreign owner must use the appropriate Form W-8.

Part II. Certification

To establish to the withholding agent that you are a U.S. person, or resident alien, sign Form W-9. You may be requested to sign by the withholding agent even if item 1, 4, or 5 below indicates otherwise.

For a joint account, only the person whose TIN is shown in Part I should sign (when required). In the case of a disregarded entity, the person identified on line 1 must sign. Exempt payees, see *Exempt payee code*, earlier.

Signature requirements. Complete the certification as indicated in items 1 through 5 below.

1. Interest, dividend, and barter exchange accounts opened before 1984 and broker accounts considered active during 1983.

You must give your correct TIN, but you do not have to sign the certification.

2. Interest, dividend, broker, and barter exchange accounts opened after 1983 and broker accounts considered inactive during 1983.

You must sign the certification or backup withholding will apply. If you are subject to backup withholding and you are merely providing your correct TIN to the requester, you must cross out item 2 in the certification before signing the form.

3. Real estate transactions. You must sign the certification. You may cross out item 2 of the certification.

4. Other payments. You must give your correct TIN, but you do not have to sign the certification unless you have been notified that you have previously given an incorrect TIN. "Other payments" include payments made in the course of the requester's trade or business for rents, royalties, goods (other than bills for merchandise), medical and health care services (including payments to corporations), payments to a nonemployee for services, payments made in settlement of payment card and third party network transactions, payments to certain fishing boat crew members and fishermen, and gross proceeds paid to attorneys (including payments to corporations).

5. Mortgage interest paid by you, acquisition or abandonment of secured property, cancellation of debt, qualified tuition program payments (under section 529), ABLE accounts (under section 529A), IRA, Coverdell ESA, Archer MSA or HSA contributions or distributions, and pension distributions. You must give your correct TIN, but you do not have to sign the certification.

What Name and Number To Give the Requester

For this type of account:	Give name and SSN of:
1. Individual	The individual
2. Two or more individuals (joint account) other than an account maintained by an FFI	The actual owner of the account or, if combined funds, the first individual on the account ¹
3. Two or more U.S. persons (joint account maintained by an FFI)	Each holder of the account
4. Custodial account of a minor (Uniform Gift to Minors Act)	The minor ²
5. a. The usual revocable savings trust (grantor is also trustee)	The grantor-trustee ¹
b. So-called trust account that is not a legal or valid trust under state law	The actual owner ¹
6. Sole proprietorship or disregarded entity owned by an individual	The owner ³
7. Grantor trust filing under Optional Form 1099 Filing Method 1 (see Regulations section 1.671-4(b)(2)(i)(A))	The grantor*
For this type of account:	Give name and EIN of:
8. Disregarded entity not owned by an individual	The owner
9. A valid trust, estate, or pension trust	Legal entity ⁴
10. Corporation or LLC electing corporate status on Form 8832 or Form 2553	The corporation
11. Association, club, religious, charitable, educational, or other tax-exempt organization	The organization
12. Partnership or multi-member LLC	The partnership
13. A broker or registered nominee	The broker or nominee

For this type of account:	Give name and EIN of:
14. Account with the Department of Agriculture in the name of a public entity (such as a state or local government, school district, or prison) that receives agricultural program payments	The public entity
15. Grantor trust filing under the Form 1041 Filing Method or the Optional Form 1099 Filing Method 2 (see Regulations section 1.671-4(b)(2)(i)(B))	The trust

¹ List first and circle the name of the person whose number you furnish. If only one person on a joint account has an SSN, that person's number must be furnished.

² Circle the minor's name and furnish the minor's SSN.

³ You must show your individual name and you may also enter your business or DBA name on the "Business name/disregarded entity" name line. You may use either your SSN or EIN (if you have one), but the IRS encourages you to use your SSN.

⁴ List first and circle the name of the trust, estate, or pension trust. (Do not furnish the TIN of the personal representative or trustee unless the legal entity itself is not designated in the account title.) Also see *Special rules for partnerships*, earlier.

*Note: The grantor also must provide a Form W-9 to trustee of trust.

Note: If no name is circled when more than one name is listed, the number will be considered to be that of the first name listed.

Secure Your Tax Records From Identity Theft

Identity theft occurs when someone uses your personal information such as your name, SSN, or other identifying information, without your permission, to commit fraud or other crimes. An identity thief may use your SSN to get a job or may file a tax return using your SSN to receive a refund.

To reduce your risk:

- Protect your SSN,
- Ensure your employer is protecting your SSN, and
- Be careful when choosing a tax preparer.

If your tax records are affected by identity theft and you receive a notice from the IRS, respond right away to the name and phone number printed on the IRS notice or letter.

If your tax records are not currently affected by identity theft but you think you are at risk due to a lost or stolen purse or wallet, questionable credit card activity or credit report, contact the IRS Identity Theft Hotline at 1-800-908-4490 or submit Form 14039.

For more information, see Pub. 5027, Identity Theft Information for Taxpayers.

Victims of identity theft who are experiencing economic harm or a systemic problem, or are seeking help in resolving tax problems that have not been resolved through normal channels, may be eligible for Taxpayer Advocate Service (TAS) assistance. You can reach TAS by calling the TAS toll-free case intake line at 1-877-777-4778 or TTY/TDD 1-800-829-4059.

Protect yourself from suspicious emails or phishing schemes.

Phishing is the creation and use of email and websites designed to mimic legitimate business emails and websites. The most common act is sending an email to a user falsely claiming to be an established legitimate enterprise in an attempt to scam the user into surrendering private information that will be used for identity theft.

The IRS does not initiate contacts with taxpayers via emails. Also, the IRS does not request personal detailed information through email or ask taxpayers for the PIN numbers, passwords, or similar secret access information for their credit card, bank, or other financial accounts.

If you receive an unsolicited email claiming to be from the IRS, forward this message to phishing@irs.gov. You may also report misuse of the IRS name, logo, or other IRS property to the Treasury Inspector General for Tax Administration (TIGTA) at 1-800-366-4484. You can forward suspicious emails to the Federal Trade Commission at spam@uce.gov or report them at www.ftc.gov/complaint. You can contact the FTC at www.ftc.gov/idtheft or 877-IDTHEFT (877-438-4338). If you have been the victim of identity theft, see www.IdentityTheft.gov and Pub. 5027.

Visit www.irs.gov/IdentityTheft to learn more about identity theft and how to reduce your risk.

Privacy Act Notice

Section 6109 of the Internal Revenue Code requires you to provide your correct TIN to persons (including federal agencies) who are required to file information returns with the IRS to report interest, dividends, or certain other income paid to you; mortgage interest you paid; the acquisition or abandonment of secured property; the cancellation of debt; or contributions you made to an IRA, Archer MSA, or HSA. The person collecting this form uses the information on the form to file information returns with the IRS, reporting the above information. Routine uses of this information include giving it to the Department of Justice for civil and criminal litigation and to cities, states, the District of Columbia, and U.S. commonwealths and possessions for use in administering their laws. The information also may be disclosed to other countries under a treaty, to federal and state agencies to enforce civil and criminal laws, or to federal law enforcement and intelligence agencies to combat terrorism. You must provide your TIN whether or not you are required to file a tax return. Under section 3406, payers must generally withhold a percentage of taxable interest, dividend, and certain other payments to a payee who does not give a TIN to the payer. Certain penalties may also apply for providing false or fraudulent information.

Vendor Form



COVER SHEET

Effective:
May 1, 2019

FOR

VENDOR INFORMATION FORM

*The enclosed Vendor Information Form is used by the Clayton County Water Authority (CCWA) for adding vendors to its financial database system that are awarded procurement or service work. This form has two parts. **Part 1** is designed to obtain general company information. Completion of this part is required to successfully add the vendors to CCWA's financial database system. **Part 2** is intended for information gathering purposes only. While information requested on Part 2 is optional to the vendors, it will help the CCWA obtain business ownership classification description from its vendors.*

Product(s) / Service(s) Provided: Select a NIGP code from the drop-down menu. If the code is unknown, you can search it by clicking the link provided on the form. Go to page 5. At the same time, press CTRL-F. This will open a small FIND box on your screen. In the box, type the key word that best describes your goods or services and click NEXT until you find the best fit. **Write down the 5 digit code number and go to the drop-down menu of this Form to select the code.**

For the purposes of executing this document, the following definitions apply:

- **Small Local Business Enterprise (SLBE)** is one that is at least 51% owned by one or more of the applicant individuals identified and a citizen or lawfully admitted permanent resident of the United States. Independently owned and operated with average annual gross receipts for the previous three years not exceeding (1) Construction Firms- \$18,250,000 (2) Professional Services Firms - \$5,500,000, Architectural Firms - \$3,750,000, Engineering Firms- \$7,500,000 and Goods & Services – less than 250 employees. Locally based, meaning located and operating in Clayton County or the ten (10) counties of Cherokee, Cobb, DeKalb, Douglas, Fayette, Fulton, Gwinnett, Henry, Rockdale and Spalding for at least one year prior to submitting application for certification.
- **A Woman Business Enterprise (WBE)** is one that is at least 51% owned by a Female, who also controls and operates the business, and is a permanent resident of the State of Georgia. The business must have a permanent, functioning office within the State of Georgia and must be lawfully licensed within the relevant jurisdiction.
- **A Minority Business Enterprise (MBE)** is one that is at least 51% owned by one of the minority groups identified below, who also control and operate the business, and are permanent residents of the State of Georgia. The business must have a permanent, functioning office within the State of Georgia and must be lawfully licensed within the relevant jurisdiction.

Minority Groups:

- Hispanic American
 - African American
 - Native American
 - Asian American
 - Pacific Islander
- **A Disabled Citizen Enterprise (DCE) of the US** refers to a business that is at least 51% owned by one or more disabled US citizens, who also control and operate the business, and are permanent residents of the State of Georgia. The business must have a permanent, functioning office within the State of Georgia, and must be lawfully licensed within the relevant jurisdiction.

Vendor Information Forms should be submitted to the Procurement Department.

**For questions related to the verification of certifications, please email
ccwa_slbe_program@ccwa.us**



VENDOR INFORMATION FORM

Effective 5/1/19

PART 1

Vendor Name: _____

Phone Number: _____ Fax #: _____

E-Mail Address: _____

Mailing Address: _____

Pay to Address: _____

Same as above

ACH is a way to move money between banks electronically. If you are interested in ACH payments, please complete all of the information below, and attach a copy of a voided check confirming your account information:

Bank Name: _____

Routing No.: _____ Account No.: _____

Account Name: _____

Remittance to Email Address: _____

Vendors should send all invoices to: [CCWA Accounts Payable@ccwa.us](mailto:CCWA_Accounts_Payable@ccwa.us)

Entity Type: Individual/Sole Proprietor Employee Owned Company Partnership
 Privately Held Corporation/LLC Publicly Owned Company Attorney
 Other ... _____

Social Security or Tax Identification Number (TIN): _____

Payment Terms: NET 30 DAYS Other: _____

PRODUCTS / SERVICES PROVIDED:
Provide NIGP Code(s)

For help finding NIGP Codes, click here: [NIGP Code Listing](#)

Required: A signed W-9 form must be submitted with this form.

PART 2

(For information gathering purposes only. You are not required to complete PART 2).

COMPANY'S OWNERSHIP CLASSIFICATION - See Cover Sheet for additional information.

To participate in the Small Local Business Program, please complete the following section:

SLBE Are you certified? Yes No Certifying Agency _____

County of Primary Business Located: _____

If you are certified as one of the following classifications, please check the appropriate box:

WBE MBE * DCE

* IF MBE, PLEASE Hispanic American African American Pacific Islander

CHOOSE ONE ONLY: Native American Asian American

If "Publicly Owned Company" has been chosen, no other designation (Hispanic American, African American, Etc.) may be chosen. This option will serve as your company's classification.

Vendor Information Forms should be submitted to ccwa_slbe_program@ccwa.us.

If your company's ownership is certified as SLBE, WBE, MBE, or DCE with the State of Georgia (GDOT) Certification Program, Clayton County, DeKalb County or with the City of Atlanta, please submit a copy of your business certification (including your phone, fax, and email address) to: ccwa_slbe_program@ccwa.us Certification from any other entity is not needed at this time.

PACKAGE LABEL

Please affix below label to the outside of your sealed envelope or package in order to route it to the proper location timely. Packages received after the specified date and time will be deemed non-responsive.



DELIVER TO: CLAYTON COUNTY WATER AUTHORITY
1600 Battle Creek Road
Morrow, GA 30260
Attention: PROCUREMENT



W.B. Casey WRRF Secondary Launder Covers

Bid ID #: 2022-WR-06

Due Date and Time: Tuesday, April 5, 2022, at 2:00 p.m. local time

VENDOR NAME: _____
Address: _____
City, State, Zip: _____

ADDENDA