



**STRONG PARTNERS.
TOUGH TRUCKS.™**

PCS30UT

LITHIUM-ION POWERED PALLET TRUCK

WWW.HYSTER.COM

> PCS30UT OVERVIEW

The Hyster® lithium-ion powered pallet truck PCS30UT offers helps to improve efficiency by reducing operator effort and assists in lowering the total cost of ownership through lower maintenance requirements. Similar to a hand pallet truck, it is compact and lightweight with minimal maintenance requirements. The PCS30UT can be operated with very little downtime, due to a 6-second battery exchange time.

- Compact, lightweight design
- Powered travelling, lifting and lowering
- Up to 3 times more efficient than a hand pallet truck
- 6-second battery exchange
- Recharge alert
- Intelligent remote control key option
- Optional large battery with 3-hour fast charger
- Emergency reverse button
- Ergonomic, multi-function handle with LCD display to maximize uptime
- Simple to maintain
- Maintenance-free components, including brushless drive motor and lithium-ion battery
- 60-second drive wheel replacement
- Durable steel frame and protective cover
- Performs well on gradients

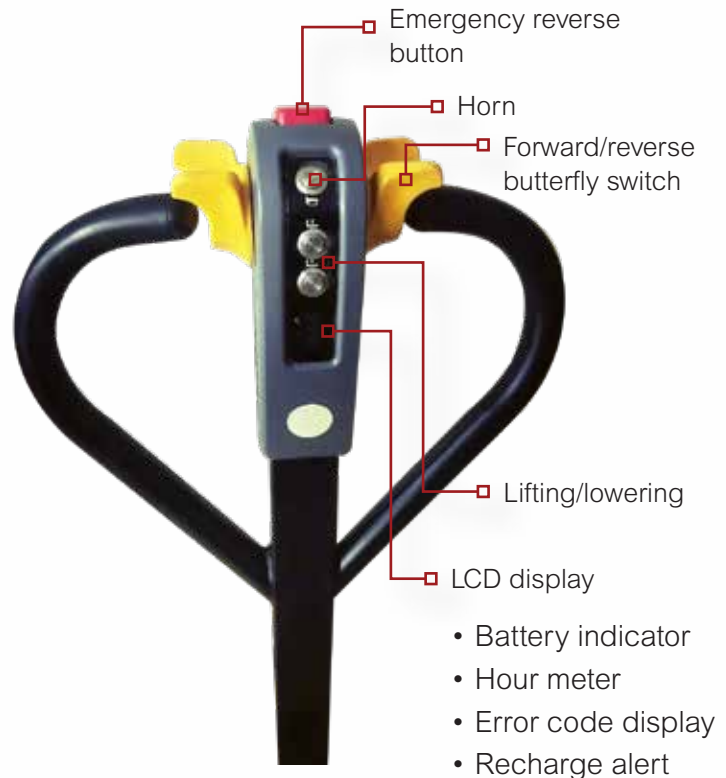

POWERED PALLET TRUCK VS. HAND PALLET TRUCK

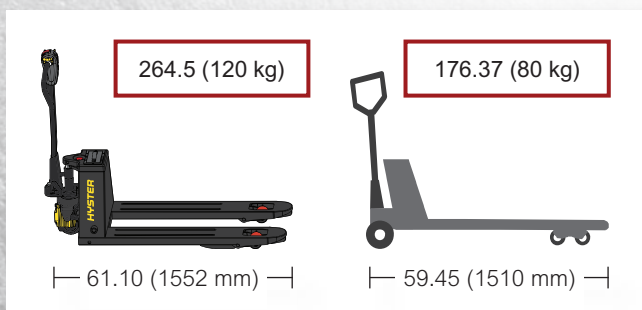

Compact and lightweight



Single/dual tandem load wheels

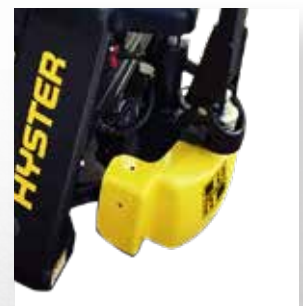

Protective cover

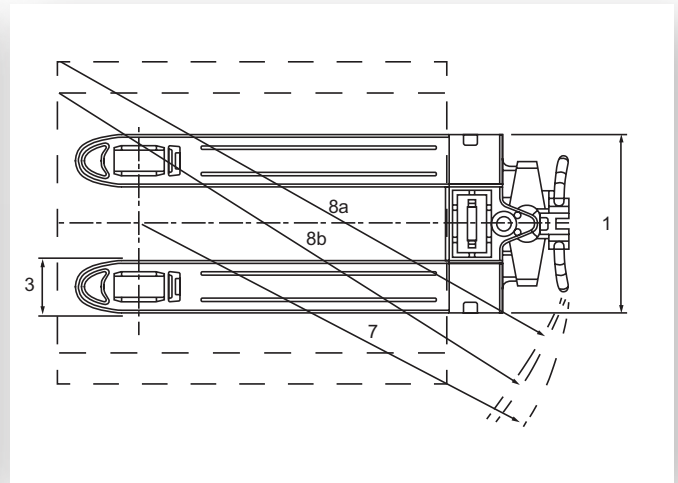
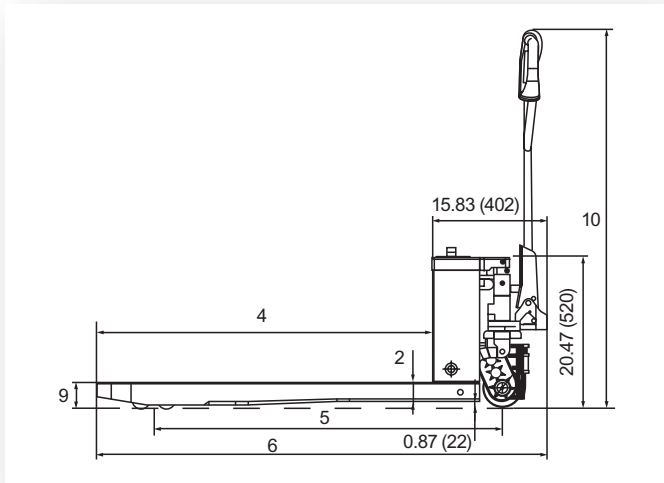

MANUFACTURER	MEASUREMENT	HYSTER
Model designation		PCS30UT
Operator type		Pedestrian
Rated capacity	lb (kg)	3300 (1500)
Load center	in (mm)	23.6 (600)
Overall fork width	[1] in (mm)	21.65 (550) / 26.97(685)
Fork dimensions	[2/3/4] in (mm)	2.28 (58) x 6.30 (160) x 45.28 (1150) / 2.28 (58) x 6.30 (160) x 48 (1220)
Wheelbase	[5] in (mm)	47.12 (1197) / 49.88 (1267)
Overall length	[6] in (mm)	61.10 (1552) / (63.86) 1622
Turning radius (raised)	[7] in (mm)	53.26 (1353) / 56.14 (1426)
Right angle stack (39.37 x 47.24 crossway / 31.50 x 47.24 lengthways)	[8a/8b] in (mm)	α 67.64 (1718) / β 66.41 (1687)
Lowered height - top of forks	[9] in (mm)	3.23 (82)
Total lift	in (mm)	4.52 (115)
Height of tiller (min. / max.)	[10] in (mm)	32.28 (820) / 45.28 (1150)
Maximum gradeability (loaded / unloaded)	%	6 / 20
Travel speed (loaded / unloaded)	mph (km/h)	2.5 (4.0) / 2.80 (4.5)
Control type		DC
Drive / lift motor	kw	0.75 / 0.5
Lift speed - loaded / unloaded (lowering speed - loaded / unloaded)	ft / min	3.54 / 4.53 (11 / 9)
Travel brake type		Regenerative
Service brake type		Electromagnetic
Service weight (includes battery)	lb (kg)	264.55 (120) / 275.58 (125)
Axle loading-laden front / rear / unladen front / rear	lb (kg)	2,500 (1134) / 1,071.4 (486) / 194 (88) / 70.5 (32)
Drive wheel x(1)	in (mm)	Ø5.51 (140) x 2.16 (55) Poly (1)
Load wheel (single x2 / dual x4)	in (mm)	Ø3.15 (80) x 3.66 (93) Poly / Ø3.14 (80) x 2.75 (70) poly
Battery type		Lithium
Battery capacity	Ah	10 / 15
Battery voltage	V	48
Power consumption in accordance with VDI cycle	kWh / h	0.42
Sound level at driver's ear EN12053	dB(A)	69

> SPECIFICATIONS AND DIMENSIONS

OPERATOR ASSIST FEATURES

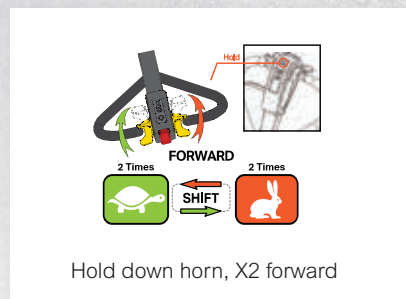

Speed setting
Convenient fast / slow pre-set speeds



Up-right drive
Maximize efficiency in tight spaces

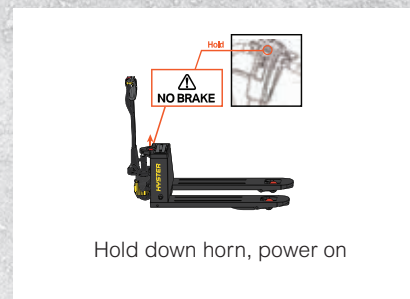

Service mode
Utilize brake release in emergencies



Hyster Company
P.O. Box 7006
Greenville, North Carolina
27835-7006
Part No. PCS30UT-BTG
4/2021 Litho in U.S.A.

Visit us online at www.hyster.com or call us at **1-800-HYSTER-1**.

Hyster,  and STRONG PARTNERS, TOUGH TRUCKS, are registered trademarks in the United States and certain other jurisdictions. Hyster products are subject to change without notice.

Trucks may be shown with optional equipment. © 2021 Hyster Company. All rights reserved.