

Typical staircase for Access #1, 62, 64, & 66

2020 UPDATE NOTE: 4x4 Posts have been increased to 6x6 for new construction

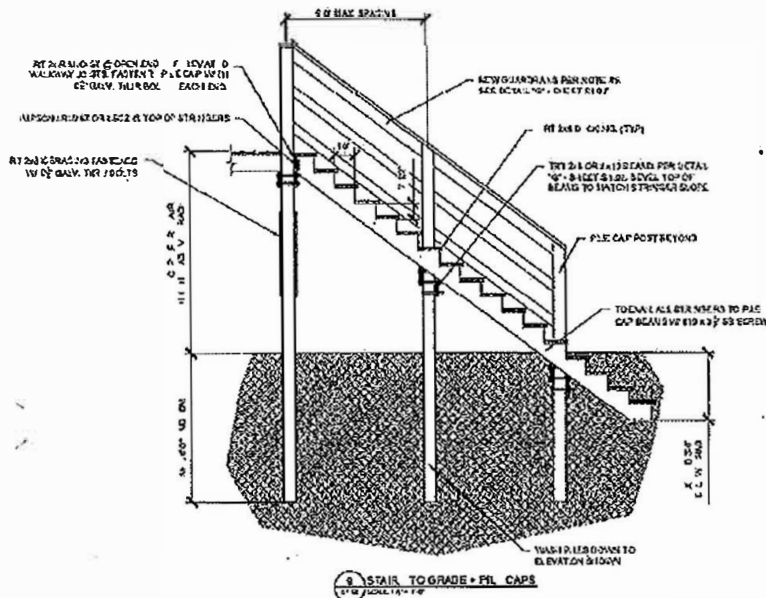

Walkovers:

- #62 (28LF deck replacement, beach staircase replacement w/15 steps-no landing)
- #64 (50LF deck replacement, beach staircase replacement w/15 steps-no landing)
- #66 (55LF deck replacement, beach staircase replacement w/14 steps-no landing)

Staircase/steps:

- 6"x 6" support posts spaced 6' apart w/6' min embedment
- 2"x 6" decking and stair treads.
- 2" x 8" bracing
- 2" x 10" cross beams at pile cap
- 2" x 6" guardrails
- 2" x 8" top rail
- 2" x 12" stringers (3 ea)

All wood components are PT

Typical Deck Framing

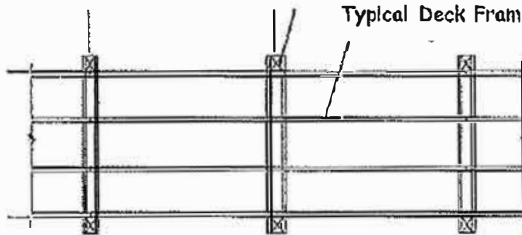

All walkovers are 4' wide elevated decks w/6x6 support posts spaced 8' apart with 2x6 deck planks, 2x8 stringers and joists, 2x10 cross beams and 42" H handrails w/2x6 guardrails and 2x8 top rail (handhold).

Applicant Representative Initials: B.S.

Sketch / Notes

Access:

#62 (28LF, 4'W deck w/typical deck framing and handrails, and a beach staircase w/15 steps, no landing),
 #64 (50LF, 4'W deck, w/typical deck framing and handrails, and a beach staircase w/15 steps, no landing).
 #66 (60LF, 4'W deck, w/typical deck framing and handrails, and a beach staircase w/14 steps, no landing)
 All are 4' wide elevated decks w/42" high handrails

Elevated Walkover Components:

- 6" x 6" support posts space 8' apart w/6' min embedment
- 2" x 8" joists/stringers
- 2" x 8" cross braces
- 2" x 6" guardrails
- 2" x 8" cross beams

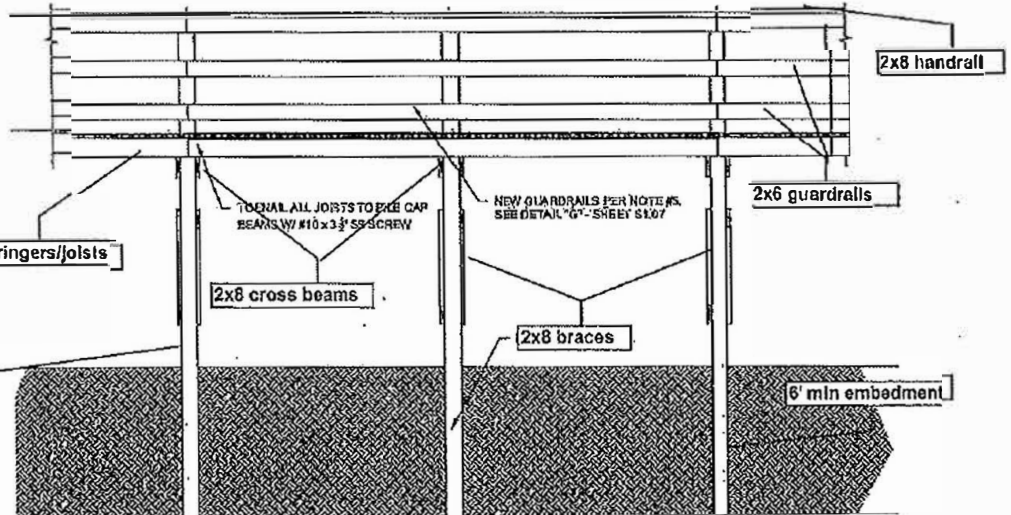
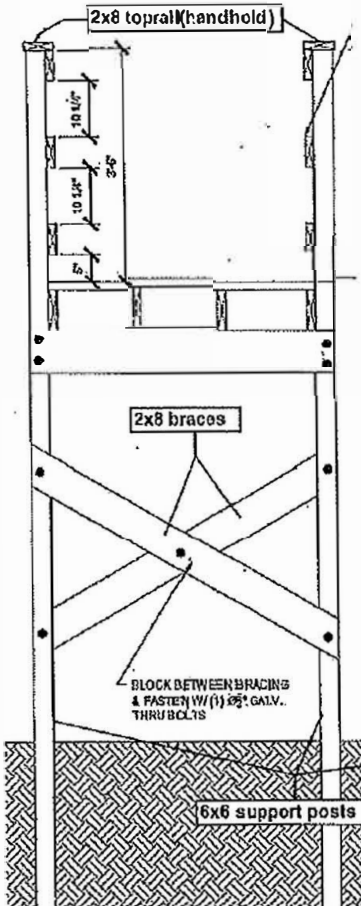

Georgetown County SC Hurricane Ian

Initial Damage Report

Latitude: 33.46713314767318
Longitude: -79.09829841934061
USNG: 17SPT7671904692
Date/Time: 10/3/2022 10:21 AM

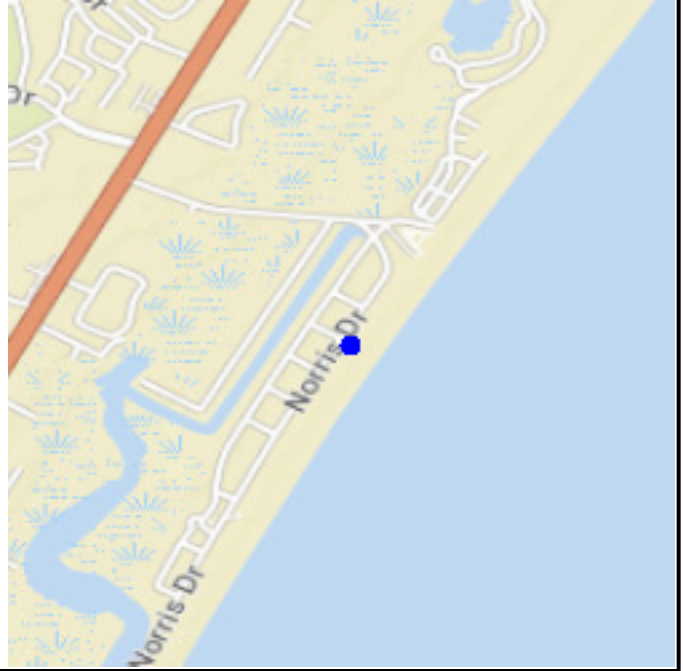

Address	
City	
Had Damage	Damaged
Type of Damage	Structure
Description	SOUTH LITCHFIELD BEACH ACCESS 62 Steps on beach side are missing. Access appears to be leaning. Several 6x6 post have been snapped off and a couple foot of the sand has been washed from the remaining legs closest to road side step



Georgetown County SC Hurricane Ian



Georgetown County SC Hurricane Ian

Initial Damage Report

Latitude: 33.46513377040016
Longitude: -79.09952787689781
USNG: 17SPT7660904469
Date/Time: 10/3/2022 9:21 AM

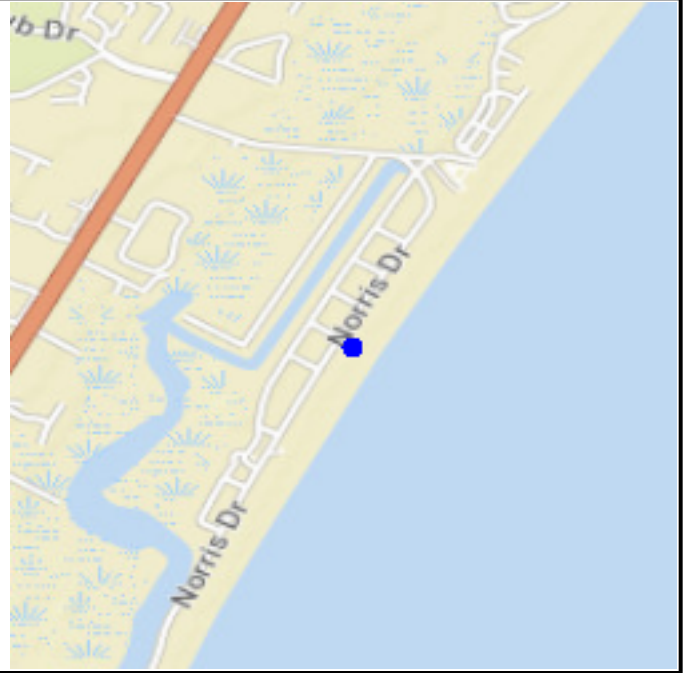

Address	
City	
Had Damage	Destroyed
Type of Damage	Structure
Description	SOUTH LITCHFIELD BEACH ACCESS 64. Basically the only thing left is the road side steps. Beach side steps as well as all railings and partial platform are gone



Georgetown County SC Hurricane Ian



Georgetown County SC Hurricane Ian

Initial Damage Report

Latitude: 33.46334155186402
Longitude: -79.10015350215053
USNG: 17SPT7655504269
Date/Time: 10/3/2022 10:18 AM

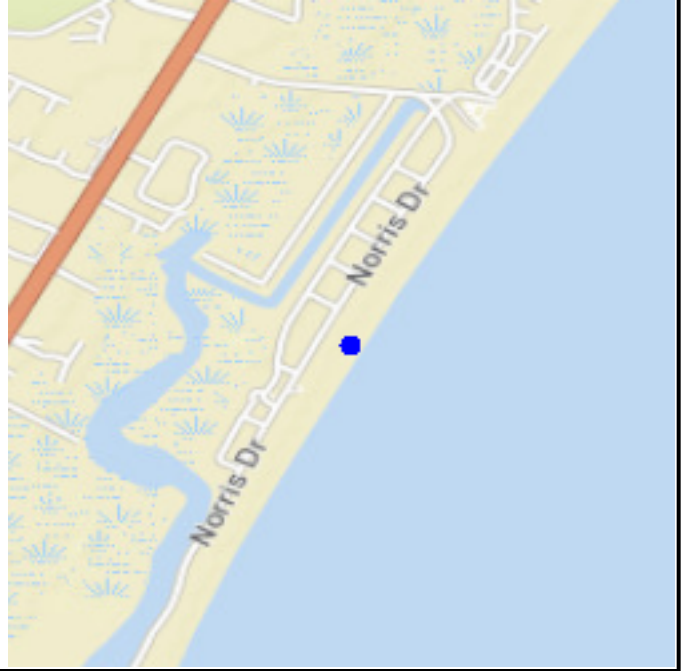

Address	
City	
Had Damage	Damaged
Type of Damage	Structure
Description	SOUTH LITCHFIELD BEACH ACCESS 66. Beach side steps are missing. Access appears to have shifted and is sitting at a slant. Appears to be about 3 foot of sand that's washed from around the post that holding structure in place and one leg isn't in the sand at all.



Georgetown County SC Hurricane Ian



ALL RIGHTS RESERVED. The EARTHWORKS Group is hereby known as EW Inc. The User agrees not to use this document, in whole or part, for any purpose or project other than the project, which is the subject of this Agreement. User agrees to waive all claims against EW Inc. resulting in any way from unauthorized changes or reuse of this document by anyone other than EW Inc. In addition, User agrees, to the fullest extent permitted by law, to indemnify and hold EW Inc., its officers, directors, employees, agents, contractors, subcontractors, and affiliates harmless from and against all claims, damages, losses, and expenses, including reasonable attorneys' fees, that may be asserted against or incurred by EW Inc. or its affiliates in connection with the project, whether or not such claims, damages, losses, and expenses are caused in whole or in part without the express written consent from EW Inc. of the purchaser. This item may not be copied, in whole or in part, without the express written consent from EW Inc. of the purchaser. The reproduction or use of this drawing without the architect/engineer's written consent is prohibited and any infringement is subject to legal action.

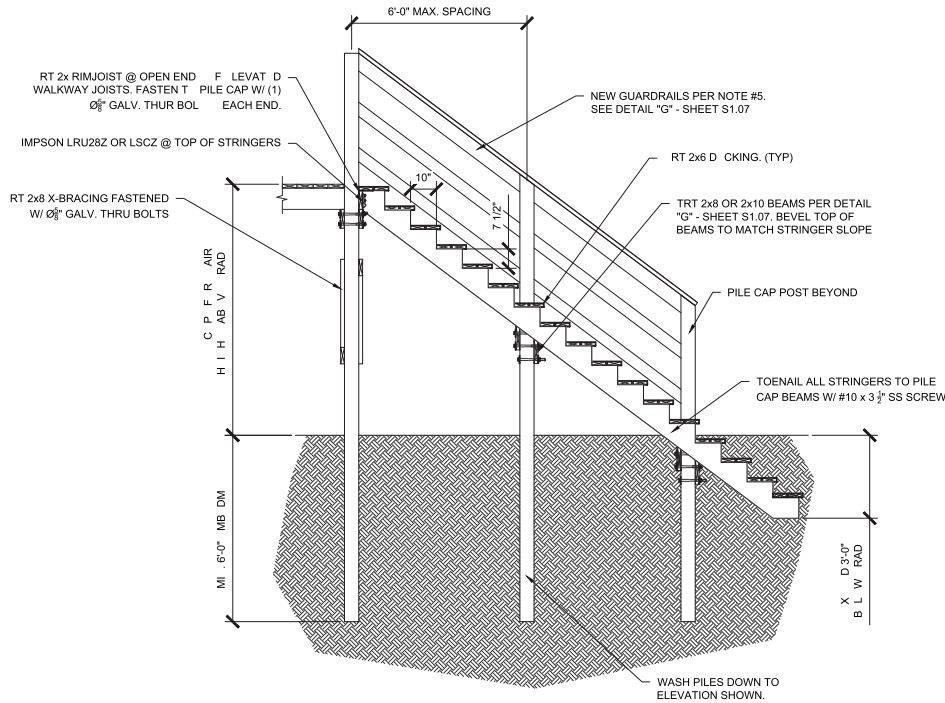
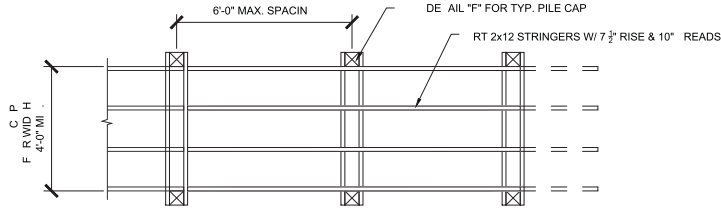

B STAIR TO GRADE + PILE CAPS
 11.02 SCALE: 1/4" = 1'-0"

NOTE: USE DETAIL "H" - SHEET S1.08 AT LOCATIONS WHERE EXISTING WALKWAY IS TEN (10) FEET OR MORE ABOVE EXISTING BEACH.

- 1.) ALL TIMBER TO BE USED SHALL BE PROCESSED ACCORDING TO SH 53.01. NO CREOSOTE-TREATED MATERIALS SHALL BE USED.
- 2.) ALL FASTENERS SHALL BE STAINLESS STEEL, U.N.O.
- 3.) STAIRS TO GRADE SHALL BE EXTENDED 3'-0" VERTICALLY & BURIED BELOW GRADE.
- 4.) NEW PILE CAPS TO BE INSTALLED SHALL BE SPACED 8'-0" O.C. MAXIMUM FOR WALKWAYS & 6'-0" O.C. MAXIMUM FOR STAIRWAYS, UNLESS NOTED OTHERWISE.
- 5.) WHERE SECTIONS (STAIRS, RAMPS, OR ELEVATED WALKWAYS) ARE REPLACED, NEW GUARDRAILS SHALL BE INSTALLED FOR THE ENTIRETY OF THE NEW LENGTH, EACH SIDE, PER DETAIL "G".

EARTHWORKS
 planning and design consultants

11655 HIGHWAY 707
 MURRELLS INLET, SC 29576
 (PAX) 843.651.7900
 (FAX) 843.651.7903
 www.earthworksgrp.com

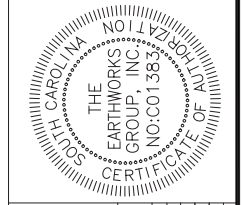
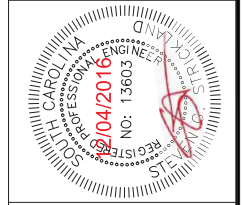

WALKWAY RAIL
 PUBLIC ACCESS
 RAILWAY CROSSING
 RAILWAY CROSSING

D RAIL "B" - AIR

ADD'L	UBI	AL	& R	VI	BY	DATE	DESCRIPTION
1	DA	DA	DA	DA	DA	DA	DA
2	DA	DA	DA	DA	DA	DA	DA
3	DA	DA	DA	DA	DA	DA	DA
4	DA	DA	DA	DA	DA	DA	DA

161168.000 R
 1.02 13

ALL RIGHTS RESERVED. The Earthworks Group is hereby known as EW Inc. The User agrees not to use this document, in whole or part, for any purpose or project other than the project, which is the subject of this Agreement. User agrees to waive all claims against EW Inc. resulting in any way from unauthorized changes or reuse of this document by anyone other than EW Inc. In addition, User agrees, to the fullest extent permitted by law, to indemnify and hold EW Inc. harmless from and against all claims, damages, losses, and expenses, including reasonable attorneys' fees, that may be asserted against or incurred by EW Inc. or its architect/engineer in connection with the design, construction, or use of this drawing without the architect/engineer's written consent is prohibited and any infringement is subject to legal action.

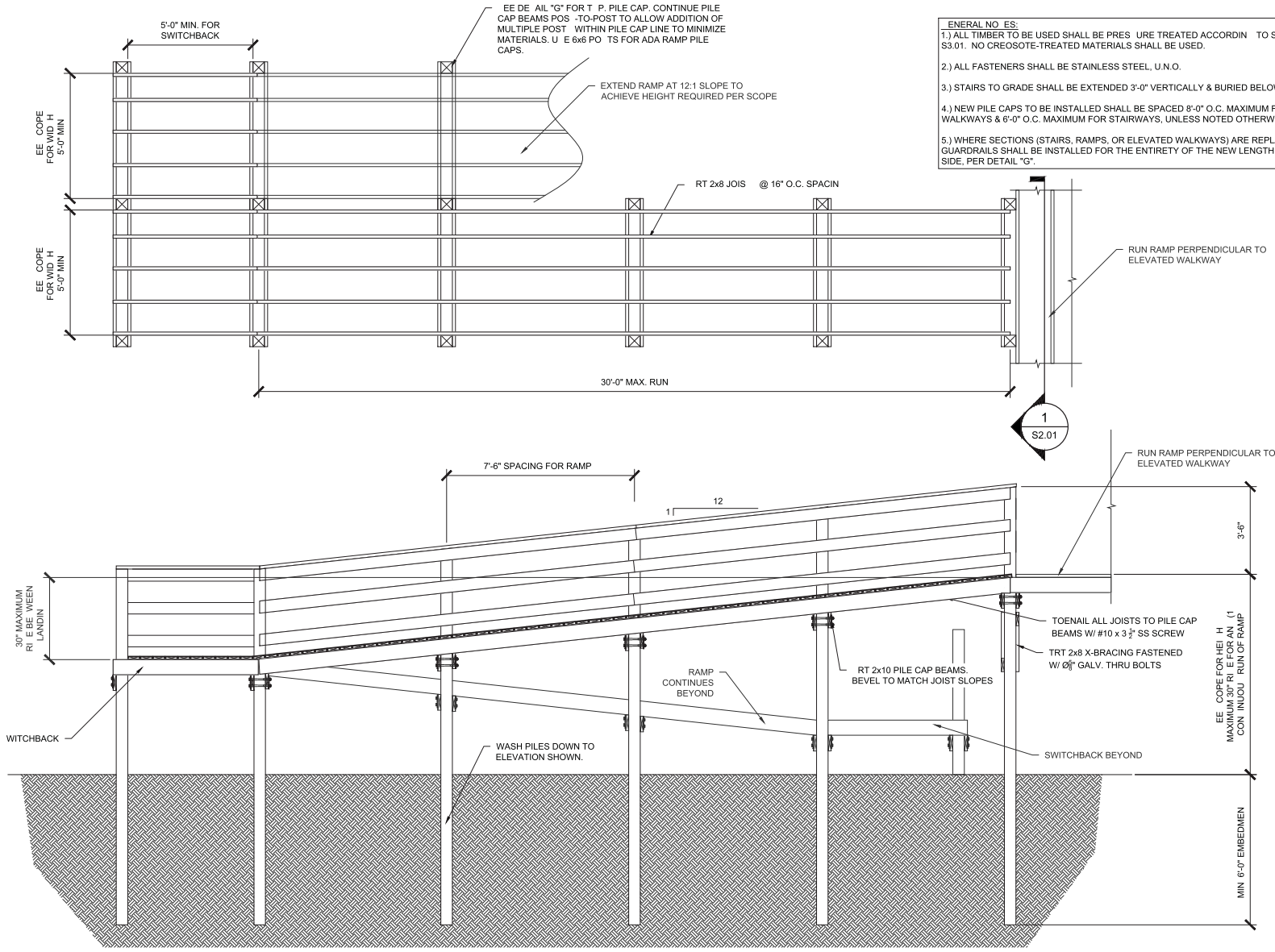

- GENERAL NOTES:
- 1.) ALL TIMBER TO BE USED SHALL BE PRESURE TREATED ACCORDING TO SHEET S3.01. NO CREOSOTE-TREATED MATERIALS SHALL BE USED.
 - 2.) ALL FASTENERS SHALL BE STAINLESS STEEL, U.N.O.
 - 3.) STAIRS TO GRADE SHALL BE EXTENDED 3'-0" VERTICALLY & BURIED BELOW GRADE.
 - 4.) NEW PILE CAPS TO BE INSTALLED SHALL BE SPACED 8'-0" O.C. MAXIMUM FOR WALKWAYS & 6'-0" O.C. MAXIMUM FOR STAIRWAYS, UNLESS NOTED OTHERWISE.
 - 5.) WHERE SECTIONS (STAIRS, RAMPS, OR ELEVATED WALKWAYS) ARE REPLACED, NEW GUARDRAILS SHALL BE INSTALLED FOR THE ENTIRETY OF THE NEW LENGTH, EACH SIDE, PER DETAIL "G".

J ACCESSIBLE RAMP
1:10 SCALE: 1/4" = 1'-0"

EARTHWORKS
planning and design consultants

11655 HIGHWAY 707
MURRELLS INLET, SC 29576
843.661.7900
(FAX) 843.661.7903
www.earthworksgroup.com

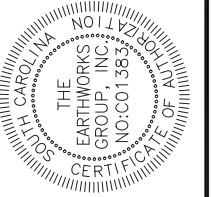
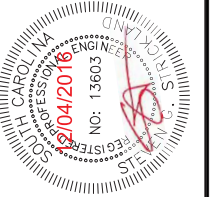

WALKOVER DECK
PUBLIC ACCESSIBLE
FOR OWN COUNCIL
PREPARED FOR
FOR OWN COUNCIL

DECK "J" - ACCESSIBLE RAMP

NO.	DATE	DESCRIPTION	BY	CHKD.
1		ISSUED FOR PERMIT		
2		REVISED		
3		REVISED		
4		REVISED		

DRAWING NAME: C:\Users\mccormack\AppData\Local\Temp\AutoCAD\2022\12\2022\123000.dwg 2022-12-30 12:30:00

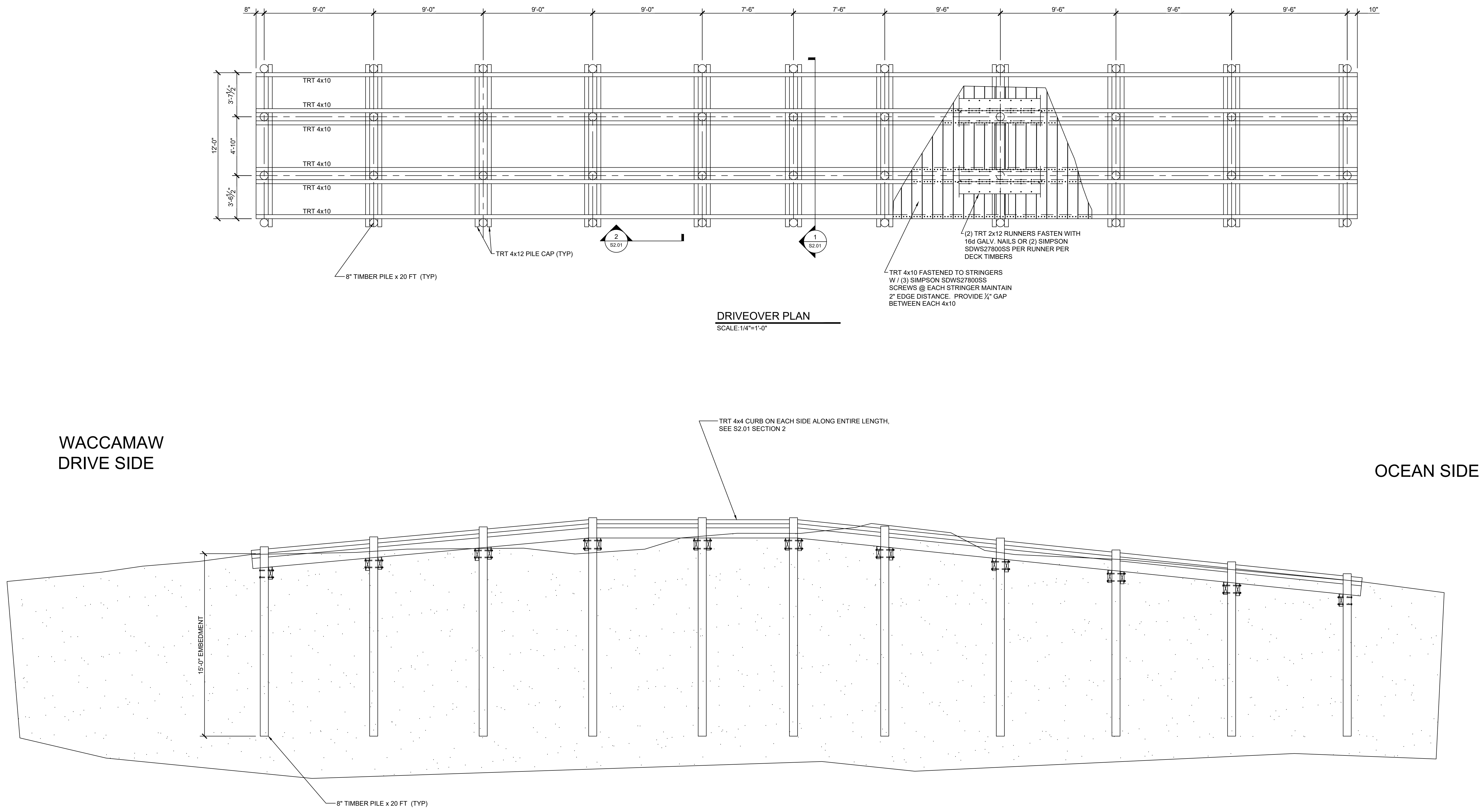

DRIVEOVER PLAN
SCALE: 1/4"=1'-0"

DRIVEOVER ELEVATION
SCALE: 1/4"=1'-0"

EARTHWORKS
planning and design consultants
11655 HIGHWAY 707
MURRELLS INLET, SC 29576
843.651.7903
(FAX) 843.651.7903
www.earthworksgroup.com

CERTIFICATE OF PROFESSIONAL ENGINEERING
STATE OF SOUTH CAROLINA
NO. 113022
THE EARTHWORKS GROUP, INC.
NO. C01383
CERTIFICATE

REVISION SCHEDULE

NO.	DATE	DESCRIPTION
1		<PRELIMINARY PLANS>
2		
3		
4		
5		
6		
7		
8		
9		
10		
11		
12		

GEORGETOWN COUNTY DRIVEOVERS
DRIVEOVER STRUCTURE

PREPARED FOR: ARC INC
771 BURGESS ROAD
MURRELLS INLET, SC

PROJECT LOCATION: BEACH DRIVE OVER STRUCTURE
GEORGETOWN, SC

PROJECT #: 221207.000
DATE: 11/22/2022
SCALE: AS NOTED
DESIGNED BY: SGS
DRAWN BY: RMM
CHECKED BY: SGS

S1.01

ALL RIGHTS RESERVED. Disclaimer: The Earthworks Group is hereby known as EWT, Inc. The User agrees not to use this document in whole or part, for any purpose or project other than the project, which is the subject of this Agreement. User agrees to waive all claims against EWT, Inc. resulting in any way from unauthorized changes or reuse of this document by anyone other than EWT, Inc. In addition, User agrees to the fullest extent permitted by law, to indemnify and hold EWT, Inc. harmless from any damage, liability or cost, including reasonable attorney's fees and costs of defense arising from any damages, losses or expenses incurred by EWT, Inc. in any way from the use of this document without the express written consent of EWT, Inc. of the purchaser. This drawing and the design therein is the property of EWT, Inc. The reproduction of use of this drawing without the architect/engineer's written consent is prohibited and any infringement is subject to legal action.

DRAWING NAME: C:\Users\mccoy\AppData\Local\Temp\AutoCAD\AutoCAD_2022\1230\1230.dwg

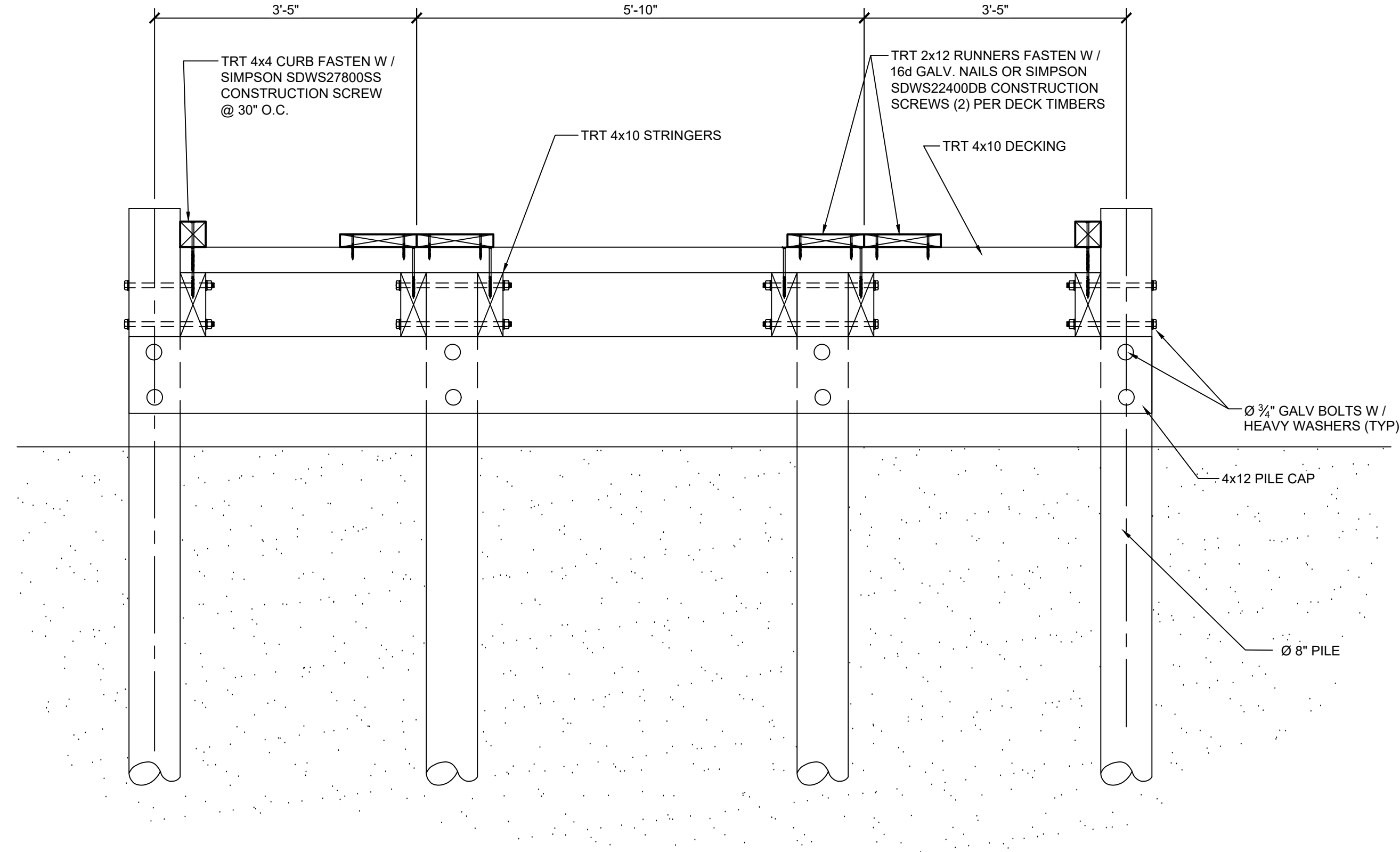
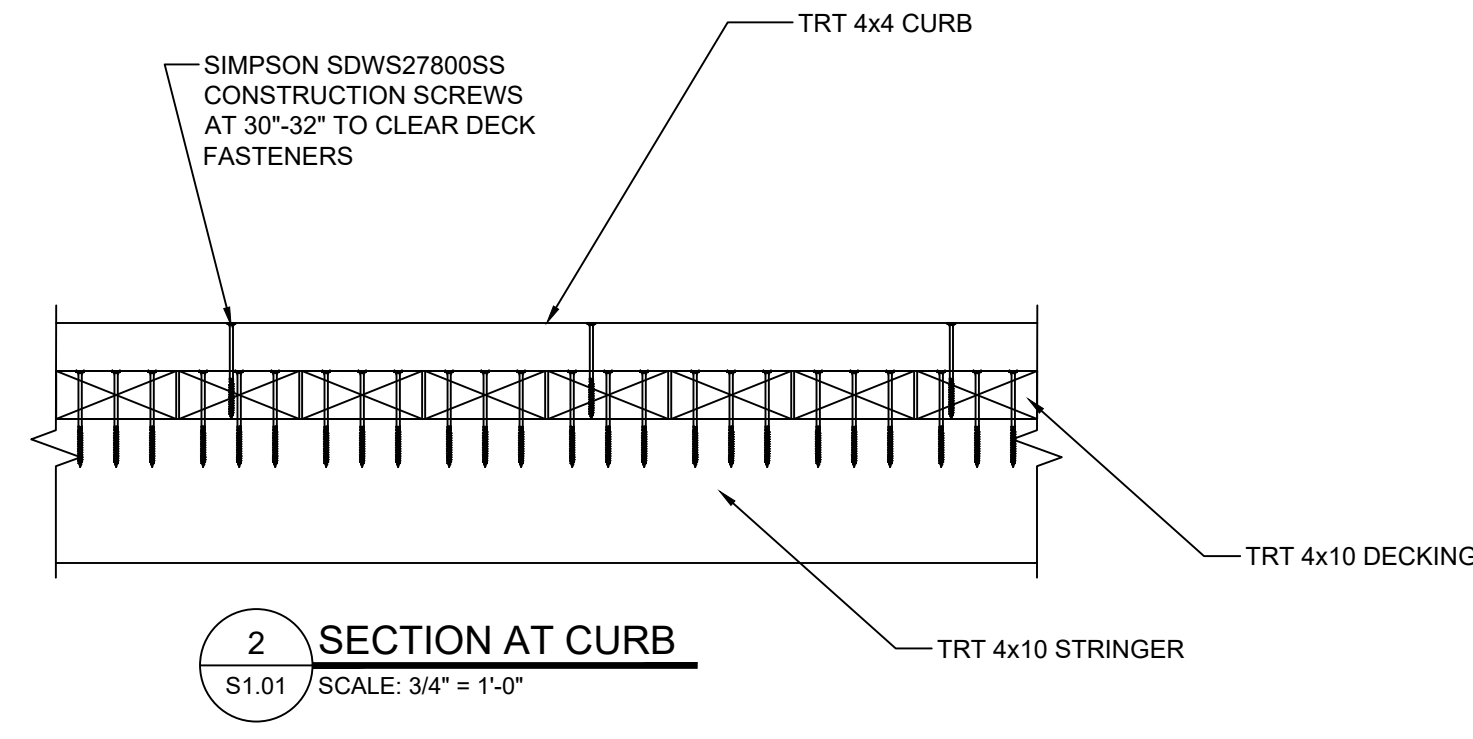

1 SECTION THRU DRIVEOVER
S1.01 SCALE: 3/4" = 1'-0"

S2.01

GEORGETOWN COUNTY DRIVEOVERS

STRUCTURAL DETAILS

PROJECT #: 221207.000

DATE: 11/22/2022

SCALE: AS NOTED

DESIGNED BY: SGS

DRAWN BY: RMM

CHECKED BY: SGS

PREPARED FOR: ARC INC
1711 BURGESS ROAD
MURRELLS INLET, SC

PROJECT LOCATION: BEACH DRIVE OVER STRUCTURE
GEORGETOWN, SC

REVISION SCHEDULE

NO.	DATE	DESCRIPTION
1	<DATE>	<PRELIMINARY PLANS>
2		
3		
4		
5		
6		
7		
8		
9		
10		
11		
12		

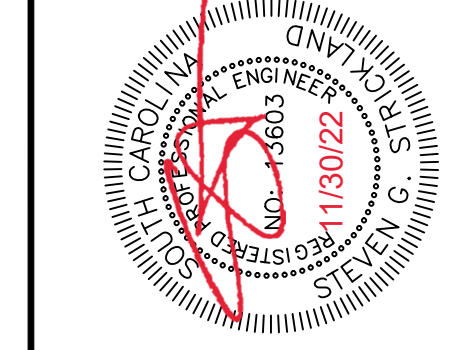
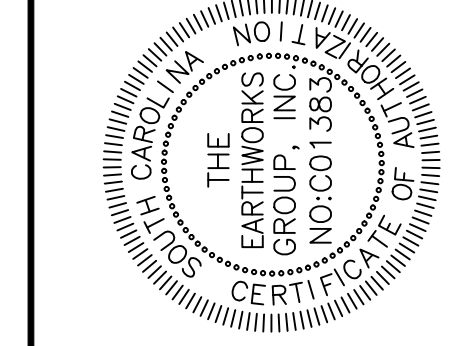

EARTHWORKS
Planning and design consultants
11655 HIGHWAY 707
MURRELLS INLET, SC 29576
843.651.7900
(FAX) 843.651.7903
www.earthworksgroup.com

ALL RIGHTS RESERVED. Disclaimer: The Earthworks Group is hereby known as EWI, Inc. The User agrees not to use this document in whole or part, for any purpose or project other than the project, which is the subject of this Agreement. User agrees to waive all claims against EWI, Inc. resulting in any way from unauthorized changes or reuse of this document by anyone other than EWI, Inc. In addition, User agrees to the fullest extent permitted by law, to indemnify and hold EWI, Inc. harmless from any damage, liability or cost, including reasonable attorney's fees and costs of defense arising from any changes made by anyone other than EWI, Inc. in any way from this document without the prior written consent of EWI, Inc. or the purchaser. This drawing and the design therein is the property of EWI. The reproduction or use of this drawing without the architect/engineer's written consent is prohibited and any infringement is subject to legal action.

STRUCTURAL NOTES

Table with 4 columns: GOVERNING CODE, 2018 INTERNATIONAL BUILDING CODE WITH SOUTH CAROLINA AMENDMENTS, LOADS ARE IN ACCORDANCE WITH ASCE 7-16. Rows include Risk Category, Dead Loads, Live Loads, Snow Loads, Wind Loads, Seismic Load Information, Geotechnical Information, Flood Design Data, and Rain Load.

GENERAL

- 1. THE STRUCTURE IS DESIGNED TO BE SELF-SUPPORTING AND STABLE AFTER THE BUILDING IS FULLY COMPLETED. IT IS SOLELY THE CONTRACTOR'S RESPONSIBILITY TO DETERMINE ERECTION PROCEDURES AND SEQUENCE, AND TO ENSURE THE STABILITY OF THE BUILDING AND ITS COMPONENT PARTS, AND THE ADEQUACY OF TEMPORARY OR INCOMPLETE CONNECTIONS, DURING ERECTION. THIS INCLUDES THE ADDITION OF ANY SHORING, SHEETING, TEMPORARY BRACING OR TIEDOWNS THAT MIGHT BE NECESSARY. SUCH MATERIAL IS NOT SHOWN ON THE DRAWINGS. IF APPLIED, THEY SHALL BE REMOVED AS CONDITIONS PERMIT. THE ENGINEER TAKES NO RESPONSIBILITY FOR CONSTRUCTION MEANS AND METHODS OR JOB SITE SAFETY DURING CONSTRUCTION. PROCESSING AND/OR APPROVING SUBMITTALS MADE BY THE CONTRACTOR WHICH MAY CONTAIN INFORMATION RELATED TO CONSTRUCTION METHODS OR SAFETY ISSUES, OR PARTICIPATION IN MEETINGS WHERE SUCH ISSUES MIGHT BE DISCUSSED, SHALL NOT BE CONSTRUED AS VOLUNTARY ASSUMPTION BY THE ENGINEER OF ANY RESPONSIBILITY FOR SAFETY PROCEDURES.

REINFORCED CONCRETE

- 1. MATERIALS:
1.a. SPECIFICATIONS: IN GENERAL, COMPLY WITH ACI 318-14 "SPECIFICATIONS FOR STRUCTURAL CONCRETE"
1.b. STRUCTURAL CONCRETE:
LOCATION Fc (PSI)
FOOTINGS 3,000
MONOLITHIC SLABS ON GRADE & ALL INTERIOR CONCRETE NOT OTHERWISE IDENTIFIED 3,500
RAISED STEMWALL SLABS & CONCRETE ON-GRADE, PIERS 3,000
BACKFILL BELOW FOOTINGS (MUD MAT) 2,000
ALL EXTERIOR CONCRETE NOT OTHERWISE IDENTIFIED 3,000
1.c. ALL DEFORMED REINFORCING BARS: Fy = 60,000 ASTM A-615 GRADE 60
1.d. MIXES: ALL CONCRETE MIXES SHALL BE DESIGNED BY THE SUPPLIER TO MEET THE REQUIREMENTS SET FORTH HEREIN.
1.d.1. SLUMP: MAXIMUM ALLOWABLE SLUMP FOR CONCRETE SHALL BE 4", UNLESS OTHERWISE NOTED OR APPROVED. IF HIGHER SLUMP IS DESIRED TO INCREASE WORKABILITY, CONTRACTOR SHALL CONSULT WITH CONCRETE SUPPLIER ABOUT USING A CONCRETE ADDITIVE THAT WILL INCREASE SLUMP WITHOUT INCREASING WATER/CEMENT RATIO OF THE CONCRETE. THE CONTRACTOR SHALL VERIFY THAT ANY CONCRETE ADDITIVES WILL NOT HAVE ANY DETRIMENTAL EFFECTS ON EMBEDDED ITEMS, FINISHES INDICATED ON PLANS, OR LIKELY FUTURE FINISHES.
1.e. FINISHING: FINISHING OF CONCRETE SHALL BE IN ACCORDANCE WITH ACI 301 (LATEST EDITION).
1.e.1. CURING: BEGINNING IMMEDIATELY AFTER PLACEMENT, CONCRETE SHALL BE PROTECTED FROM PREMATURE DRYING, EXCESSIVELY HOT OR COLD TEMPERATURES, AND MECHANICAL INJURY AND SHALL BE MAINTAINED WITH MINIMAL MOISTURE LOSS AT RELATIVELY CONSTANT TEMPERATURE FOR THE PERIOD NECESSARY FOR THE HYDRATION OF THE CEMENT AND HARDENING OF THE CONCRETE. THE MATERIALS AND METHODS OF CURING SHALL CONFORM TO ACI 301.
2. FIELD MANUAL: PROVIDE AT LEAST ONE COPY OF THE ACI FIELD REFERENCE MANUAL, SP-15, IN THE FIELD OFFICE AT ALL TIMES.
3. MISCELLANEOUS:
3.a. BENT BARS, IF REQUIRED, SHALL BE BENT PER MANUFACTURER RECOMMENDATIONS, UNLESS OTHERWISE APPROVED.
3.b. PROVIDE SUPPORTS AS REQUIRED TO MAINTAIN ALIGNMENT OF SCHEDULED REINFORCING.
3.c. GROUT UNDER COLUMN BASE PLATES SHALL BE NON-SHRINKING TYPE. THE USE OF LEVELING PLATES AT COLUMN BASES IS PROHIBITED. GROUT BELOW BEARING PLATES, SETTING PLATES AND COLUMN BASE PLATES IS TO BE INSTALLED ONLY AFTER THE STEEL IS PLUMBED.
4. SLABS:
4.a. CONCRETE SLABS ON GRADE SHALL BE CONSTRUCTED IN ACCORDANCE WITH ACI 302.1R-96 "GUIDE FOR CONCRETE".
4.b. CONTROL JOINTS SHALL BE SPACED IN INTERIOR SLABS ON GRADE AT A MAXIMUM OF 20 FEET ON CENTER AND IN EXTERIOR SLABS ON GRADE AT A MAXIMUM OF 10 FEET ON CENTER, UNLESS OTHERWISE NOTED.
4.c. CONTROL JOINTS SHALL BE PRODUCED USING CONVENTIONAL PROCESSES WITHIN 4 TO 12 HOURS AFTER THE SLAB HAS BEEN FINISHED. REINFORCING STEEL SHALL NOT EXTEND THROUGH THE CONTROL JOINT.

- 4.d. CONSTRUCTION JOINTS PERMITTED ONLY WHERE SHOWN OR AS APPROVED BY THE STRUCTURAL ENGINEER. CONSTRUCTION JOINTS ARE TO BE KEVED. KEYWAYS SHALL BE 1-1/2 INCHES DEEP x 1/3 MEMBER THICKNESS.
4.e. PROVIDE 6 MIL POLYETHYLENE VAPOR BARRIER BETWEEN SUBGRADE AND CONCRETE SLAB.
4.f. TREAT SOIL FOR TERMITES PRIOR TO PLACEMENT OF CONCRETE.
4.g. PREPARE SITE BY REMOVING ORGANIC/EXPANSIVE SOILS AND COMPACTING TO 95% PROCTOR DRY DENSITY.
4.h. SLAB FINISHES:
4.h.1. ALL OFFICE SPACES, RETAIL, RESIDENTIAL AND SIMILAR SLABS SHALL HAVE MACHINE FINISH WITH 1/8" PER 10'-0" TOLERANCE.
4.h.2. ALL EXTERIOR, WET SURFACE, DRIVEWAYS, SIDEWALKS AND SIMILAR SLABS SHALL BE FINISHED WITH ROUGH NON-SKID SURFACE (BROOM FINISH). BRUSH LINES IN THE FINISH SHALL BE PARALLEL TO THE DIRECTION OF SLOPE.
4.i. THE CONCRETE SLAB ON GRADE HAS BEEN DESIGNED USING A SUBGRADE MODULUS OF K=250 PCI AND A DESIGN LOADING OF 2,000 PSF. THE STRUCTURAL ENGINEER OF RECORD IS NOT RESPONSIBLE FOR DIFFERENTIAL SETTLEMENT, SLAB CRACKING OR OTHER FUTURE DEFECTS RESULTING FROM UNREPORTED CONDITIONS MITIGATING THE ABOVE ASSUMPTIONS.
4.j. REINFORCEMENT FOR SLAB ON GRADE SHALL BE PLACED AT A LOCATION BETWEEN THE CENTER AND UPPER THIRD OF THE SLAB.
5. OPENINGS:
5.a. OPENINGS SHOWN ARE FOR BIDDING PURPOSES ONLY. COORDINATE THEIR EXACT SIZES AND LOCATIONS WITH HVAC, PLUMBING, AND OTHER REQUIREMENTS BEFORE PROCEEDING WITH WORK.
5.b. IF ANY OPENING NOT SHOWN ON THE PLANS IS REQUIRED, SECURE APPROVAL OF THE STRUCTURAL ENGINEER BEFORE PROCEEDING
5.c. PROVIDE TWO #5 BARS AROUND ALL SLAB OPENINGS, EXTENDING 2 FEET BEYOND OPENING IN EVER DIRECTION, UNLESS NOTED OTHERWISE. OPENINGS NOT EXCEEDING 16 INCHES x 16 INCHES MAY BE SLEEVED AS REQUIRED BY WORKING THE REINFORCING STEEL AROUND THEM.
6. FOOTINGS AND PIERS:
6.a. INSTALL DOWELS IN FOOTINGS TO MATCH VERTICAL PIER OR WALL REINFORCING STEEL.
6.b. PROVIDE CORNER BARS AT FOOTING CORNERS TO MATCH HORIZONTAL REINFORCING. MINIMUM LAP LENGTH WITH HORIZONTAL REINFORCING STEEL = 35 BAR DIAMETERS.
6.c. BACKFILL AGAINST BOTH SIDES OF WALLS EQUALLY UNTIL THE LOWER ELEVATION IS ATTAINED.
6.d. PROVIDE MINIMUM 18 INCH THICK LAYER OF GRANULAR BACKFILL FULL HEIGHT OF ALL FOUNDATION WALLS.
6.e. CAST IN CONTINUOUS DOVE TAIL ANCHOR SLOTS ON VERTICAL SURFACES WHERE MASONRY ABUTS, 16 INCHES ON CENTER FOR PARALLEL MASONRY SURFACES. INSTALL AT CENTERLINE OF MASONRY FOR PERPENDICULAR MASONRY SURFACES.
6.f. PROVIDE LEAN CONCRETE UNDER FOUNDATIONS FOR ACCIDENTAL OVER EXCAVATION, SOFT SPOTS, AND TRENCHES.
6.g. VENTILATING FOUNDATION WALL OPENINGS SHALL BE WITHIN 3 FEET OF EACH CORNER OF THE BUILDING. AREA OF OPENINGS SHALL BE NOT LESS THAN 1 SQ. FT. FOR EACH 150 SQ. FT. OF UNDER FLOOR SPACE AREA.
7. SPLICES: UNLESS OTHERWISE NOTED, MINIMUM LAP SPLICE LENGTHS TO BE AS FOLLOWS:
REINFORCING STEEL LAP LENGTH
VERTICAL BARS (INCLUDING DOWELS) 30 BAR DIAMETERS
HORIZONTAL BARS IN SLABS & FOOTINGS 30 BAR DIAMETERS
8. CONCRETE COVER: UNLESS OTHERWISE NOTED, DETAIL REINFORCING TO PROVIDE CONCRETE COVER AS FOLLOWS:
STEEL LOCATION CONCRETE COVER
CONCRETE CAST AGAINST AND PERMANENTLY EXPOSED TO EARTH 3 INCHES
CONCRETE EXPOSED TO EARTH OR WEATHER:
#5 BARS AND SMALLER 1-1/2 INCHES
OTHERS 2 INCHES
PILE CAPS 2-1/2 INCHES

C. STRUCTURAL LUMBER

- 1. SPECIFICATIONS: UNLESS SPECIFICALLY SHOWN OTHERWISE, DESIGN, FABRICATION AND ERECTION SHALL BE GOVERNED BY THE LATEST EDITION OF THE FOLLOWING:
1.a. NATIONAL DESIGN SPECIFICATION FOR WOOD CONSTRUCTION.
1.b. U.S. PRODUCT STANDARD PS1
2. MATERIALS:
2.a. STRUCTURAL LUMBER (INCLUDING BEARING AND EXTERIOR WALL STUDS): MINIMUM PROPERTIES OF SPRUCE-PINE-FIR #2, ALLOWABLE STRESSES PER THE NATIONAL DESIGN SPECIFICATION SUPPLEMENT, LATEST EDITION, 19% MAXIMUM MOISTURE CONTENT. OTHER ACCEPTABLE SPECIES INCLUDE HEM-FIR, SOUTHERN PINE AND DOUGLAS FIR-LARCH.
2.b. STRUCTURAL SHEATHING (PLYWOOD & OSB):
2.b.1. FOR ROOFS: OSB OR C-D PLUGGED, 5-PLY, EXPOSURE 1, 7/16" THICK.
2.b.2. FOR WALLS: OSB OR C-D PLUGGED, 5-PLY EXPOSURE 1, 7/16" THICK.
2.b.3. FOR WALLS NOT AT SHEAR WALLS: OSB 7/16" THICK WITH PANEL INDEX W24, EXPOSURE 1.
2.c. ALL FRAMING EXPOSED TO THE WEATHER OR IN CONTACT WITH MASONRY OR CONCRETE SHALL BE PRESSURE TREATED IN ACCORDANCE WITH THE AMERICAN WOOD PRESERVERS ASSOCIATION SPECIFICATIONS.
2.c.1. WHERE POSSIBLE, ALL EXPOSED CUTS AND HOLES SHOULD BE COMPLETED BEFORE TREATMENT.
2.c.2. CUTS AND HOLES DUE TO ON-SITE FABRICATION SHALL BE BRUSHED WITH TWO COATS OF COPPER NAPHTHENATE SOLUTION CONTAINING A MINIMUM OF 2% METALLIC COPPER IN SOLUTION (PER AWWA STD. M4).
3. CONNECTIONS:
3.a. JOISTS & RAFTERS TO SIDES OF BEAMS: 16 GA. GALVANIZED STANDARD JOIST HANGERS, UNLESS OTHERWISE NOTED.
3.b. RAFTERS AND TRUSSES TO TOPS OF WALLS AND BEAMS: 18 GA. GALVANIZED HURRICANE ANCHORS.
3.c. PLYWOOD TO ROOF TRUSSES OR RAFTERS: NAILED WITH RING-SHANK NAILS. SEE STRUCTURAL WOOD PANEL NOTES BELOW.
3.c.1. PROVIDE PLYWOOD CLIPS AT MID-SPAN OF PLYWOOD BETWEEN SUPPORTS, OR
3.c.2. PROVIDE BLOCKING BETWEEN ROOF FRAMING AT PLYWOOD EDGES AND NAIL WITH EDGE NAILING PATTERN.
3.d. ALL METAL CONNECTIONS SHALL BE SIMPSON OR USP.
3.e. ALL CONNECTORS TO BE INSTALLED PER MANUFACTURER'S INSTRUCTIONS.
3.e.1. CONTACT ENGINEER WITH QUESTIONS PERTAINING TO HOLDDOWNS SPECIFIED ON PLANS.
3.f. STUD COLUMNS SHALL BE SECURED WITH TWO ROWS OF 3 INCH 10d NAILS SPACED 24 INCHES ON CENTER, UNLESS OTHERWISE NOTED.
3.g. LOAD VALUES FOR 8d, 10d, 16d AND 20d DESIGNATIONS IN THE FASTENER SCHEDULES THROUGHOUT THESE PLANS REFER TO COMMON WIRE NAILS, UNLESS OTHERWISE NOTED. NAILS SHALL CONFORM TO A RECOGNIZED NATIONAL STANDARD, SUCH AS ASTM F1667, AS PRESCRIBED BY THE MODEL BUILDING CODES.

D. DRIVEN PILES:

THE CONTRACTOR SHALL APPOINT A COMPETENT INSPECTOR QUALIFIED BY EXPERIENCE AND TRAINING. THE INSPECTOR SHALL BE PRESENT AT ALL TIMES DURING PILE DRIVING OPERATIONS AND SHALL INSPECT ALL WORK IN CONNECTION WITH THE INSTALLATION OF THE PILES.

THE INSPECTOR SHALL KEEP THE FOLLOWING RECORDS FOR EACH PILE:

- A. TYPE OF PILE
B. SIZE OF PILE
C. HAMMER MAKE, TYPE, SIZE, WEIGHT, AND FALL OF RAM
D. RATED BLOWS PER MINUTE AND ENERGY PER BLOW
E. DRIVING RECORD FOR THE FULL LENGTH OF THE PILE; BLOWS PER FT.
F. DRIVEN LENGTH BELOW CUTOFF
G. PILE TIP ELEVATION
H. PILE CUTOFF ELEVATION
THE RECORD SHALL BE KEPT UP-TO-DATE IN A NEAT AND LEGIBLE MANNER AND SHALL BE AVAILABLE FOR REVIEW BY THE ENGINEER. A COPY OF THE RECORD SHALL BE PROVIDED TO THE ENGINEER AT THE COMPLETION OF EACH DAY'S WORK.

QUALITY ASSURANCE:

MANUFACTURER'S CERTIFICATION; SUBMIT THE COPIES OF MANUFACTURE CERTIFICATION THAT THE PILING COMPLIES WITH THE SPECIFIED REQUIREMENTS.

TIMBER PILES PRESERVATIVE TREATMENT: THE CONTRACTOR SHALL BE RESPONSIBLE FOR THE QUALITY OF THE TREATED WOOD

PRODUCTS. AWWA QCIP QUALITY MARK AWWA ND-1, AWWA ND-4 WILL BE ACCEPTED AS EVIDENCE OF COMPLIANCE WITH

DELIVERY, STORAGE, AND HANDLING, STORE PILES IN ACCORDANCE WITH AWA MA.

PROVIDE STANDARD CLASS B SOUTHERN PINE CLEAN-PEELED PILES CONFORMING TO ASTM D 25. PILES SHALL BE IN ONE PIECE. SPLICES WILL NOT BE PERMITTED. EACH TREATED PILE SHALL BE BRANDED BY THE PRODUCER, IN

ALL PILES SHALL BE A MINIMUM OF 45 FEET LONG. MINIMUM TIP DIAMETER SHALL BE 8 INCHES. MINIMUM BUTT DIAMETER SHALL BE 12 INCHES (MEASURED 3 FEET FROM THE BUTT).

TREAT PILES BY THE FULL-CELL PRESSURE PROCESS IN ACCORDANCE WITH AWWA U1 (COMMODITY SPECIFICATION A, USE CATEGORY 4C) FOR ROUND TIMBER PILES, AWWA U1 (COMMODITY SPECIFICATION A, USE CATEGORY 4B) FOR SAWN TIMBER PILES, AWWA C3 FOR MARINE PILING.

E. TIMBER POSTS:

REFERENCED STANDARD

THE PUBLICATIONS LISTED BELOW FORM A PART OF THIS SPECIFICATION TO THE EXTENT REFERENCED. THE PUBLICATIONS ARE REFERRED TO IN THE TEXT BY THE BASIC DESIGNATION ONLY.

AWPA U1 1990 PILES, PRESSURE TREATMENT AWWA M4. 1990 CARE OF PRESSURE TREATMENT AWWA M6 1988 BRANDS USED ON FOREST PRODUCTS AWWA MP-4 1988 MARINE PILING PRESSURE TREATED WITH WATERBORNE WATERS

AWPA QCIP 1988 PRESSURE TREATED LUMBER, TIMBERS PLYWOOD CONSTRUCTION POLES, PILES AND SPECIAL PURPOSE USE PRODUCTS
INSPECTION AND ACCEPTANCE OF PILES ACCEPTANCE WILL BE ON THE BASIC CERTIFICATION, INSPECTION OF MATERIALS PROPOSED TO BE INCORPORATED IN THE WORK, RECEIPT OF, PILE DRIVING RECORDS, AND INSPECTION OF THE COMPLETED PRODUCT.

POST INSTALLATION FOR WALKWAYS AND STAIRS
THE CONTRACTOR SHALL AUGER ALL POSTS INTO THE SAND TO THE MINIMUM DEPT SPECIFIED ON THE PLANS. ALL POSTS SHALL BE A MINIMUM OF 16 FEET UNLESS A LONGER LENGTH IS REQUIRED DUE TO DUNE HEIGHT. CONTRACTOR SHALL INSPECT ALL WORK IN CONNECTION WITH THE INSTALLATION OF THE POSTS.

MANUFACTURER'S CERTIFICATION; SUBMIT THE COPIES OF MANUFACTURE CERTIFICATION THAT THE PILING COMPLIES WITH THE SPECIFIED REQUIREMENTS.

QUALITY ASSURANCE:

TIMBER POST PRESERVATIVE TREATMENT: THE CONTRACTOR SHALL BE RESPONSIBLE FOR THE QUALITY OF THE TREATED WOOD PRODUCTS. AWWA QCIP QUALITY MARK AWWA ND-1, AWWA ND-4 WILL BE ACCEPTED AS EVIDENCE OF COMPLIANCE WITH DELIVERY, STORAGE, AND HANDLING, STORE POSTS IN ACCORDANCE WITH AWA MA.

ALL POSTS SHALL BE A MINIMUM OF 16 FEET LONG.
TREAT POSTS BY THE FULL-CELL PRESSURE PROCESS IN ACCORDANCE WITH AWWA U1 (COMMODITY SPECIFICATION A, USE CATEGORY 4C) FOR
TREAT PILES TO A RETENTION RATE OF 2.5 LB. CUJ / FT.

TREATMENT REQUIREMENTS FOR MARINE CONSTRUCTION:

Table with 3 columns: BELOW WATER MEMBERS, FRESH WATER, SALT WATER. Rows include SAWN PILES, WALLERS, SHEET PILES, CROSS BRACING.

Table with 3 columns: SPLASH ZONE MEMBERS, FRESH WATER, SALT WATER. Rows include SPLIT PILE CAPS & STRINGERS.

Table with 3 columns: ABOVE WATER MEMBERS, FRESH WATER, SALT WATER. Rows include DECKING, HANDRAILS, WALLCAPS.

Table with 3 columns: TIMBER STRUCTURE SPECIFICATION NOTES, FRESH WATER, SALT WATER. Rows include DECKING, HANDRAILS, WALLCAPS.

TIMBER STRUCTURE SPECIFICATION NOTES

ALL FACE AND ANCHOR PILES USED IN CONSTRUCTION SHOULD BE SPECIFIED IN ACCORDANCE WITH ASTM D25. PRESERVATIVE TREATMENT SHALL BE TO AWWA STANDARDS C-3 & C-18 (UC4C, 5A, 5B, 5C).

ALL FASTENERS AND TIE RODS SHOULD BE HOT-DIP GALVANIZED PER ASTM A-153 OR BE CORROSION RESISTANT (BITUMASTOIC COATED OR 300 SERIES STAINLESS STEEL).

ALL CUTS, HOLES AND INJURIES TO THE SURFACE OF TREATED WOOD SHOULD BE FIELD PROTECTED BY FIELD TREATMENT MEETING AWWA STANDARD M4.

ALL TREATED WOOD PRODUCTS SHOULD BE HANDLED AND FIELD FABRICATED IN ACCORDANCE WITH AWWA STANDARD M4 FOR THE CARE OF PRESERVATIVE TREATED WOOD PRODUCTS.

FOR FURTHER INFORMATION ON FRESH AND SALTWATER SPECIFICATIONS, CONSULT THE AWWA BOOK OF STANDARDS AND OTHER PUBLICATIONS.

PLANT INSPECTION:
THE ENGINEER RESERVES THE RIGHT TO PERFORM PLANT INSPECTION OF THE TREATING PROCESS. PROVIDE THE ENGINEER WITH A MINIMUM 3-WEEK ADVANCE NOTICE, INDICATING LOCATION OF THE INITIAL PRESERVATIVE TREATMENT. ALLOW THE ENGINEER ACCESS TO THE PLANT FOR INSPECTION

TOLERANCES IN AUGURING PILES: AT CUTOFF ELEVATION, BUTT SHALL BE WITHIN 4 INCHES OF THE LOCATION INDICATED. MANIPULATION TO MOVE PILES INTO POSITION WILL BE PERMITTED ONLY WITHIN THE AFOREMENTIONED TOLERANCE TO RETURN THE PILE TO THE DESIGN LOCATION. A VARIATION OF NOT MORE THAN 0.50 INCH PER FOOT OF PILE LENGTH FROM THE REQUIRED ANGLE FOR BATTER PILES WILL BE PERMITTED. REMOVE AND REPLACE WITH NEW PILES THOSE DAMAGED, MISPLACED, DRIVEN BELOW DESIGN CUTOFF, OR DRIVEN OUT OF ALIGNMENT.

EXECUTION
INSPECT PILES WHEN DELIVERED AND WHEN IN THE LEADS IMMEDIATELY BEFORE AUGURING. CUT PILES AT CUTOFF ELEVATION BY SAWING. CUTOFF ELEVATION FOR PILES SHALL BE A MINIMUM OF 7 FT ABOVE MEAN HIGH WATER.

INSTALLATION OF POSTS
AUGERING SHALL BE THE PREFERRED METHOD FOR THE INSTALLATION OF VERTICAL POSTS.

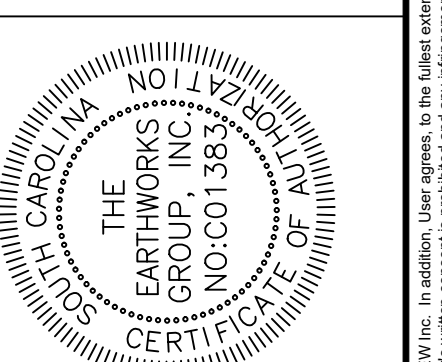
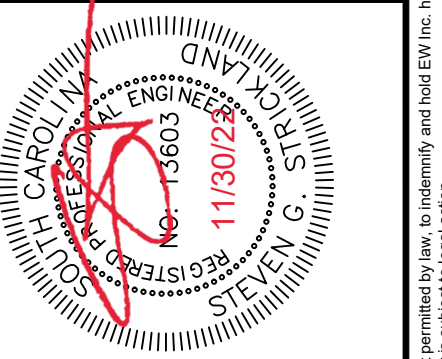

REVISION SCHEDULE table with columns: NO., DATE, DESCRIPTION, BY. Includes a row for PRELIMINARY PLANS.

GEORGETOWN COUNTY DRIVEOVERS STRUCTURAL NOTES. PREPARED FOR: ARC INC, 1711 BURGESS ROAD, MURRELLS INLET, SC. PROJECT LOCATION: BEACH DRIVE OVER STRUCTURE, GEORGETOWN, SC.

Table with 4 columns: PROJECT #, DATE, SCALE, DESIGNED BY, DRAWN BY, CHECKED BY. Values: 221207/000, 11/22/2022, AS NOTED, SGS, RMM, SGS.

S3.01

Original Wooden Structure = 4 x 95' 265 Norris Drive # 62

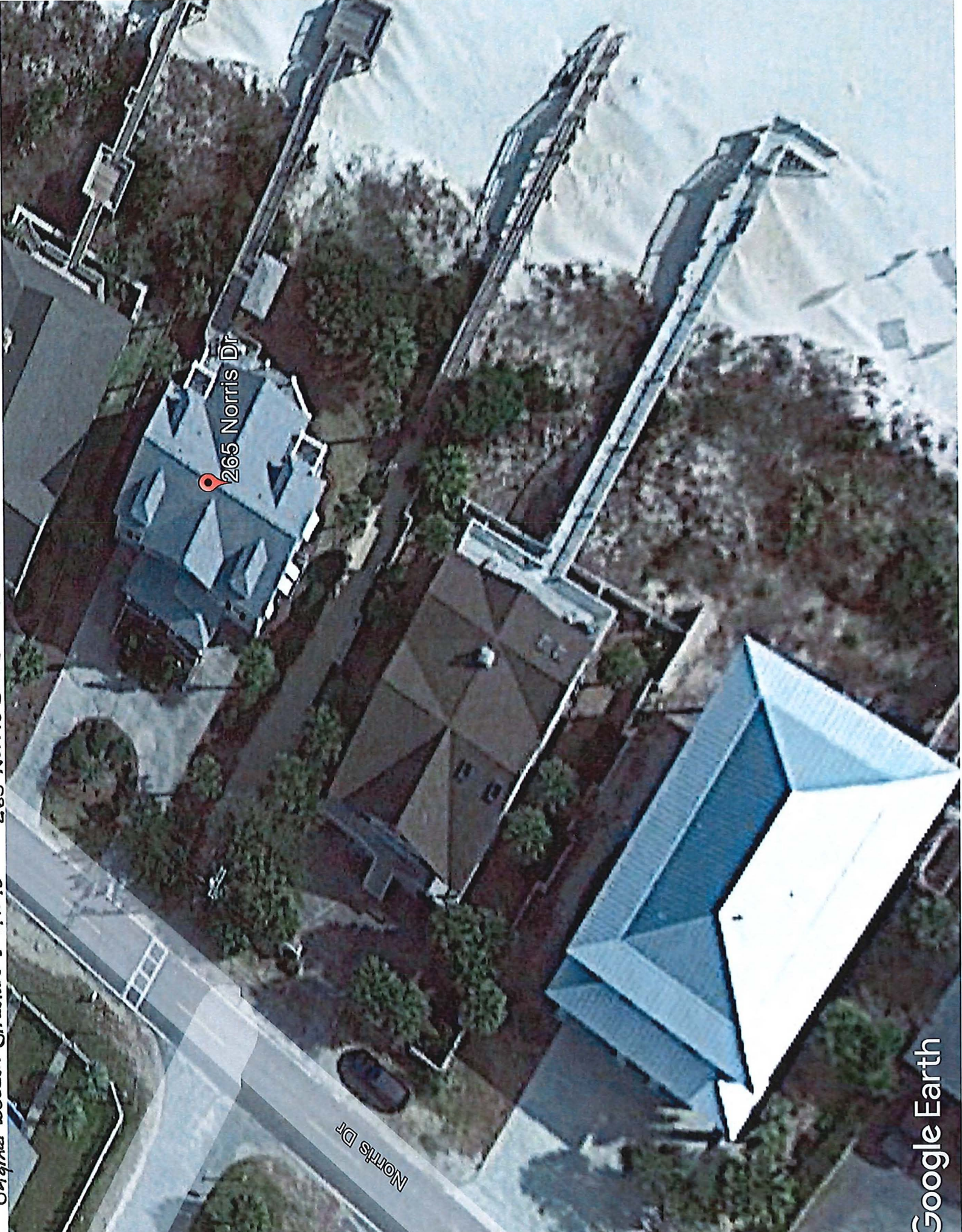

Norris Dr

Original Structure : 4 x 82' # 64
417 Norris Drive



Google Earth

Original Structure : 4x90
539 Norris Drive # 66

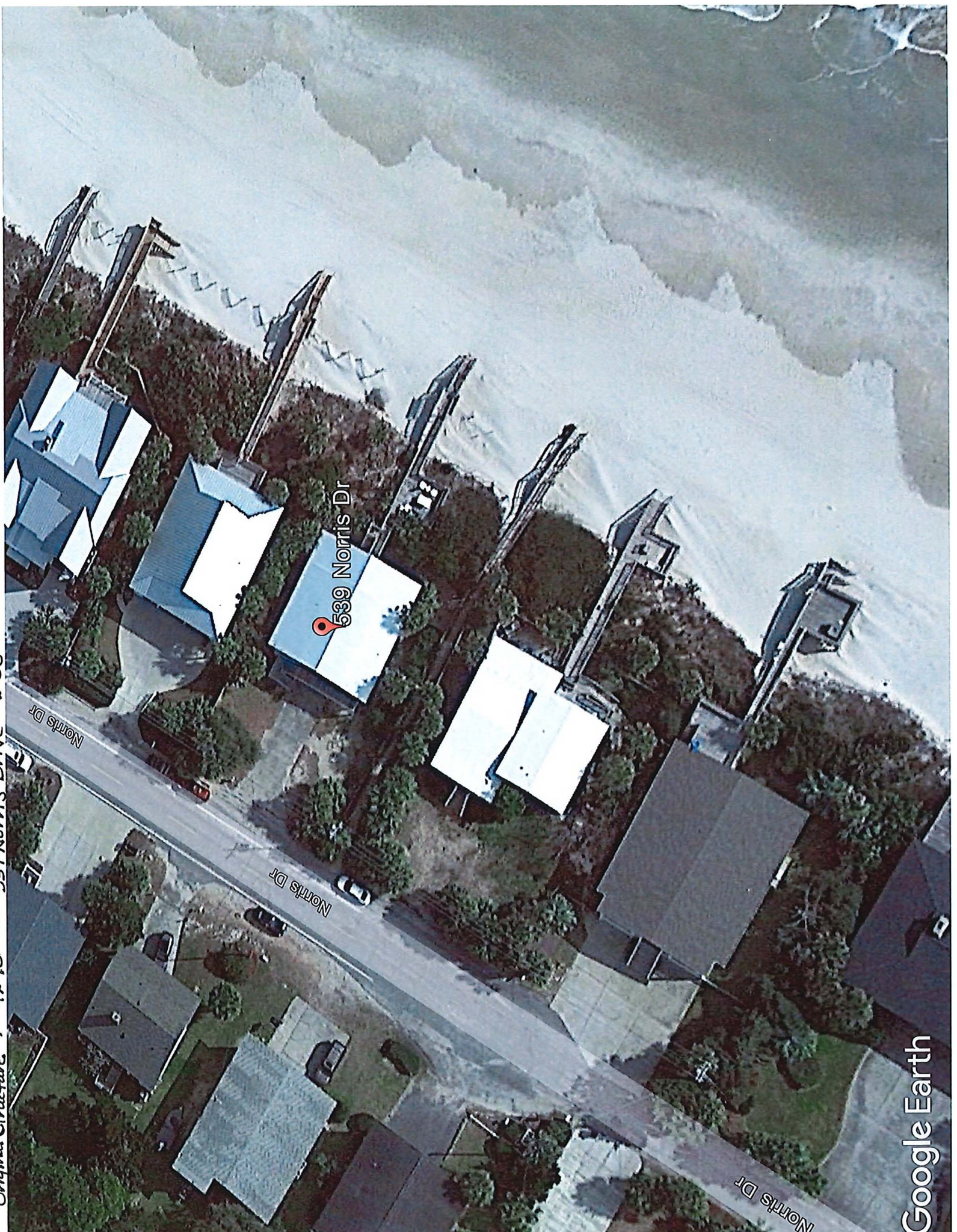

Google Earth