



REQUEST FOR BID

BID NO.: 19-2233 Washington Park - New Park Construction

DATE: August 28, 2019

Summary: The Rockford Park District invites qualified firms to bid on site demolition and removals, site grading, storm water drainage installation, asphalt paving, concrete flatwork, playground equipment and surfacing installation, fencing, site furnishings and sports equipment installation, landscaping, and turf establishment at Washington Park, 3617 Delaware St., Rockford, IL 61102.

Pre-Bid Conference: Thursday, September 5, 2019 at 2:30 p.m., Rockford Park District, Webbs Norman Center Board Room, 401 S. Main St., Rockford, IL 61101

Bid Opening: Thursday, September 19, 2019 at 2:30 p.m., Rockford Park District, Webbs Norman Center Board Room, 401 S. Main St., Rockford, IL 61101

PARK COMMISSIONERS

Ian K. Linnabary	President
Scott Olson.....	Vice President
Jack L. Armstrong	Secretary
Julianne C. Elliott	Commissioner
Tyler Smith	Commissioner

Jay Sandine...Executive Director

401 SOUTH MAIN STREET - ROCKFORD, ILLINOIS 61101 - TELEPHONE (815) 987-8800 - FAX (815) 987-8877
Serving the Communities of Cherry Valley, Loves Park, New Milford and Rockford

TABLE OF CONTENTS

Cover Letter	3
General Conditions of All Bids.....	4
Terms and Conditions of This Bid	13
Insurance Requirements	17
Project Schedule	23
Specifications	24
Supplied Equipment Details	41
Bid Offer Form.....	71
Sub-Contractor's List.....	77
Minority Participation Form.....	78
Sealed Bid Label	79
Project Drawings	<i>Bound Separately</i>

The Rockford Park District invites qualified firms to bid on site demolition and removals, site grading, storm water drainage installation, asphalt paving, concrete flatwork, playground equipment and surfacing installation, fencing, site furnishings and sports equipment installation, landscaping, and turf establishment at Washington Park, 3617 Delaware St., Rockford, IL 61102.

This project is being financed, in part, with funds from the State of Illinois Department of Natural Resources "Open Space Land Acquisition and Development (OSLAD) grant program. The local sponsor shall encourage 1) minority business firms to submit bids on the approved project, and 2) successful contract bidders to utilize minority businesses as subcontractors for supplies, equipment, services and construction.

The Rockford Park District honors prevailing wages. If applicable, the awarded Contractor, including subcontractors, is required to comply with all provisions of the Illinois Prevailing Wage Act, including the payment of wages and fringe benefits as required by law, and the submission of certified payroll transcripts. A current copy of the Illinois Department of Labor Prevailing Wage Rates can be obtained from the following website: <http://www.illinois.gov/idol/Laws-Rules/CONMED/Pages/Rates.aspx>.

Please submit the bid on the enclosed Bid Offer Form and return in a "Sealed Bid" envelope showing the bid number, date and time of opening in the lower left-hand corner of the return envelope. Failure to include the bid offer form properly completed and signed will result in the submission being rejected.

Rockford Park District welcomes the opportunity to assist guests with disabilities to enjoy ALL the facilities, programs, and services.

Please direct any questions to Tamara Pugh, Purchasing Manager, at (815) 969-4094.

GENERAL CONDITIONS FOR ALL BIDS

These instructions, terms and conditions are standard for all requests for bids issued by Rockford Park District. The Park District may delete, supersede or modify any of these standard instructions for a particular bid by indicating such change in the bid instructions, in the special conditions of the bid or in the specifications/statement of work. Any and all special conditions that may vary from these general conditions shall prevail over these general conditions. All segments of the general conditions may not apply to all bids/proposals. The general conditions are terms and conditions that the Rockford Park District expects its contractors/vendors to meet. By bidding, the respondent agrees to be bound by these requirements unless otherwise noted in the bid.

1. PRICING SELECTION

The Rockford Park District reserves the right to reject any or all prices or bids submitted. Bids will be awarded on a lump sum or on an individual basis.

2. PURCHASE ORDERS

The Rockford Park District reserves the right to increase or decrease quantities shown on bid. It also reserves the right to cancel purchase orders if delivery is not complete within one hundred and twenty days (120) days after issuance or if delivery date indicated on bid is not met by company.

3. AWARD SELECTION AND CRITERIA

Bids will be awarded to the lowest responsible bidder complying with the conditions and specifications presented herein. Bids that are submitted taking exceptions to the specifications or with exclusions, qualifications or caveats shall be deemed non-compliant to the specifications and will be subject to rejection. Lowest responsible bidder is defined in Rockford Park District Ordinance 2013-O-03, approved April 5, 2013, as follows:

Responsible Bidder for: Ordinance 2013-O-03 projects meets as of the job specifications, the following applicable criteria and submits evidence of such compliance for both general contractors and any or all subcontractors.

- A. All applicable laws prerequisite to doing business in Illinois.
- B. Evidence of compliance with
 - i. Federal Employer Tax Identification Number or Social Security Number (for individuals).
 - ii. Provision of Section 2000(e) of Chapter 21, Title 42 of the United States Code and Federal Executive Order No. 11246 as amended by Executive Order 11375 (known as the Equal Opportunity Employer provisions).

GENERAL CONDITIONS FOR ALL BIDS

- iii. Documents evidencing current registration with the Illinois Department of Revenue (i.e. UI account number);
 - iv. Disclosure of any federal, state or local tax liens or tax delinquencies against the contractor or any officers of the contractor in the last five (5) years.
- C. Certificates of insurance indicating the following coverages: general liability, workers' compensation, completed operations, automobile, hazardous occupation, product liability, and professional liability.
- D. Compliance with all provisions of the Illinois Prevailing Wage Act, including wages, submission of certified payroll records, medical and hospitalization insurance and retirement for those trades covered in the act.
- E. Participation in apprenticeship and training programs applicable to the work to be performed on the projects which are approved by and registered with the United States Department of Labor's Office of Apprenticeship and Training.
- F. Documents evidencing any professional or trade license required by law or local ordinance for any trade or specialty area in which the contractor is seeking a contract award. Additionally, the contract must disclose any suspension or revocation of such license held by the company, or of any director, officer or manager of the company.
- G. A statement that individuals who will perform work on the public works project on behalf of the contractor are properly classified as either (i) an employee or (ii) an independent contractor under all applicable state and federal laws and local ordinances.
- H. Compliance with all provisions of the Illinois Substance Abuse Prevention on Public Works Projects Act; which compliance and evidence of same, shall be required on all Rockford Park District public works projects regardless of dollar amount of such project(s).
- I. Participation in contractor's safety and health activities and programs including: (i) a written safety policy statement signed by a company representative; and (ii) a completed Contractor Safety & Health Questionnaire.
- J. Maintains a written safety manual that applies to, or will be modified to fit, the project at issue.
- K. Ensures all sub-contractors hired by the responsible bidder to perform duties on Rockford Park District public works projects are in compliance with all

GENERAL CONDITIONS FOR ALL BIDS

requirements of the responsible bidder ordinance for: a) all construction contracts in excess of \$10,000, and; b) for all contracts (regardless of the dollar amount) for electrical work, and/or for fire protection work, and/or for HVAC work and/or for plumbing work, (as defined by the Rockford Park District, in its discretion).

- L. The Rockford Park District honors prevailing wages to be paid. For awards \$25,000.00 or greater, the awarded Contractor, including subcontractors, is required to comply with all provisions of the Illinois Prevailing Wage Act, including the payment of wages and fringe benefits as required by law, and the submission of certified payroll transcripts.
- M. All invoices for Prevailing Wage work must be submitted with CERTIFIED PAYROLL RECORDS. The Rockford Park District will not pay any invoice for prevailing wage work that does not have appropriate certified payroll records attached.

The lowest responsible bidder is determined not only by price, but also by quality of product and service, past experience with same products, services offered, warranties, long-range costs, delivery, and similar such items, as judged by the Rockford Park District. All rights are reserved by the Board of Commissioners to determine whether the selection, in its judgment, meets the needs or purposes intended. Lowest responsible bid will be determined by the Board of Commissioners, in its sole discretion as that combination of base bid, alternates, and /or deducts that the Board determines to be in the best interest of the Rockford Park District. Such decisions shall be final and not subject to recourse.

Following award selection, all bidders will be notified through Demandstar.com as to the name of the successful bidder, together with price and conditions. A purchase order will be placed by the Rockford Park District with the successful bidder.

The Bidder shall bear all the costs associated with the preparation and submission of the response and the Park District shall not be responsible or liable for any costs, regardless of the conduct or outcome of this solicitation.

No bids may be withdrawn after the official opening. All bids submitted must be valid for a minimum of one hundred twenty (120) days after the date set for the bid opening. Bids are submitted to the Board for approval at a regular Rockford Park District Board meeting.

A signed, fully executed Bid Offer Form must be included in the submission for the bid to be considered responsive. Omissions or altered versions of the Bid Offer Form may result in the bid being rejected. Bidder's signature on the Bid Offer Form will be construed as acceptance of and willingness to comply with all applicable local, state and federal laws.

GENERAL CONDITIONS FOR ALL BIDS

4. METHOD OF AWARD

The award will be made in the best interest of the Rockford Park District, as determined by the Board of Commissioners, based upon the low total price and/or line-item by line-item, to the Lowest Responsible Bidder(s) that meet the requirements listed in this Request for Bid. Contracts/purchase orders may be made to multiple contractors/vendors.

5. SEALED BID

It shall be the responsibility of the bidder to insure that the "sealed bid" envelope is properly identified. Return the bid in a sealed envelope showing the vendor name, bid number, and date and time of opening in the lower left-hand corner (a label is enclosed for convenience). Bids must be handed to a Rockford Park District employee for proper recording of time and date. Bids submitted via UPS, FedEx, or special courier is encouraged to place the sealed bid label on the outside of the package. If the carrier does not allow for labels to be added, Vendor must indicate in the Reference Line that the package is a bid. Vendors are encouraged to make it well known that the content of the package is a bid. Rockford Park District U.S. Mail is delivered in the late afternoon each weekday. Vendors submitting a bid by U.S. Mail are encouraged to take this into consideration when coordinating the bid delivery to ensure the submission has arrived at the specified bid opening date and time.

6. ERRORS AND OMISSIONS

Should a mistake be discovered upon the reading of the bids at the public opening, it shall be reserved by the Rockford Park District to determine if the mistake was by the District or the bidder. It is further provided that the Rockford Park District, after this determination, shall make the decision as to acceptability or rejection. This decision shall be final and not subject to recourse. No advantages shall be taken by either party of manifest clerical errors or omissions in the specifications. All bidders are requested to notify the Rockford Park District immediately of any errors or omissions that may be encountered.

7. LATE SUBMISSIONS

Bids will not be accepted after the scheduled date and time of opening, unless it is evidenced and determined that the bid was actually in the Rockford Park District's possession prior to the scheduled opening date and time, and inadvertently misplaced while in the Rockford Park District's possession. In many instances it is impossible to determine whom the bid is from unless it is opened, and in that case, the bid will be opened, address secured and returned immediately.

8. TOTAL PRICING

The Rockford Park District is not subject to Federal Excise Tax or Illinois Retailers Occupational Tax. Quote all prices F.O.B., Rockford, Illinois. F.O.B. Rockford, Illinois, is defined as meaning the price submitted on the bid sheet is the total price to the

GENERAL CONDITIONS FOR ALL BIDS

Rockford Park District, including all freight and delivery charges. Under no circumstances may prepaid charges be added to the invoice.

9. TAXATION

86 Illinois Administrative Code, Ch. 1, Sec. 130.2075 provides that the sale of materials to construction contractors for incorporation into public improvements which are required to be transferred to a unit of local government upon completion, are exempt from the Retailers Occupation Tax and Use Tax. This relates both to contractors who do work specifically under contracts for public entities and for developers who are required by subdivision or other ordinances to dedicate the improvements, such as street, water, sewer, sidewalks or drainage to the governmental body after completion. The contractor is to retain records with the active registration number issued by the Department of Revenue to the governmental unit.

10. DELIVERY / COMPLETION DATE

Bidders shall indicate in appropriate space on Bid Offer Form, delivery or completion date of items(s) or service(s). Delivery or completion shall be made by the date specified within the specifications, and/or by the date as agreed upon between vendor and owner. (Weather permitting.) When applicable, contractor has thirty days to complete the mutually agreed upon punch list items. The contractor shall pay any additional consultant fees that may be required to complete the project after the thirty-day period.

11. SUBSTITUTIONS

If and wherever, in the specifications, a brand name or catalog number is mentioned, it is only for the purpose of establishing a grade or quality required. Since the Rockford Park District does not wish to rule out other competition, the phrase "or approved equal" is added. The Rockford Park District will be the sole judge as to equality.

The Rockford Park District shall be the sole and final judge as to whether any substitute is of equivalent or better quality. The Rockford Park District's decision is final and will not be subject to recourse by any person, firm, or corporation.

12. EQUIPMENT REMOVAL

If and whenever removal of any existing material or equipment from the job site is required, the contractor or vendor shall contact the Rockford Park District to determine ownership of said material. If the Rockford Park District desires to keep, District staff will remove; if not, it will be the contractor's/vendor's responsibility for removal, as covered in specifications.

13. COMPLIANCE WITH LAWS AND ROCKFORD PARK DISTRICT POLICIES; DRUG/ALCOHOL FREE WORK ENVIRONMENT

All services, work and materials must comply with all federal and state laws, county ordinances, rules and regulations that in any manner affect the production and sale of

GENERAL CONDITIONS FOR ALL BIDS

the product or service contained herein. In the event federal or state funds are being used to fund this contract additional certifications, attached as addenda, will be required. Lack of knowledge on the part of the vendor will in no way be cause for release of this obligation. If the Rockford Park District becomes aware of violation of any laws on the part of the vendor, it reserves the right to reject any bid, cancel any contract and pursue any other legal remedies deemed necessary.

Additionally, the Rockford Park District is committed to fostering a safe and secure environment. To do this, the Rockford Park District strives towards a proactive effort to make the environment free from the effects of alcohol and drugs. While the intent is not to intrude into the private lives of the contracted vendors, the Rockford Park District does expect vendors to report for duty and to remain in a condition suitable to perform the duties assigned to the highest level of efficiency.

Contractor is responsible for maintaining a Drug/Alcohol Free Work Environment and a safe and secure work environment for contractor's business, Rockford Park District, and customer/patron interests.

Additionally the Rockford Park District requires compliance with all applicable provisions of the Illinois Substance Abuse Prevention on Public Works Projects Act, regardless of dollar amount of project.

Contractor shall submit the company's Drug/Alcohol Free Workplace Policy upon award along with the current Certificate of Insurance, Performance Bond and signed contracts

Additionally, all contractors will also be required to annually certify, in writing, that:

- A. Per state statute (720 ILCS 5/11-9.4-1) It is unlawful for any contractors for the Rockford Park District to allow its employees who have been convicted of being a sexual predator or a child sex offender to knowingly be present in any public park building or on real property comprising any public park when any person under the age of 18 is present. No employee, subcontractor, or other personnel (hereafter, "contractor personnel") being used by contractor/vendor to perform this contract or who is otherwise being placed on Rockford Park District property in connection with the services and/or materials to be provided under this contract has committed any of the crimes identified in of the Rockford Park District's "Criminal History Check, Arrest, and Conviction Policy,"
- B. The contractor/vendor maintains a workplace drug and alcohol policy that applies to all contractor personnel used by contractor/vendor to perform this contract or who is otherwise being placed on Rockford Park District property in connection with the services and/or materials to be provided under this contract. As part of this policy, the contractor requires that whenever there is reasonable suspicion (based upon observed behavior on the job, credible information of possession or

GENERAL CONDITIONS FOR ALL BIDS

use, etc.) to suspect that contractor personnel may be under the influence of drugs and/or alcohol, the contractor personnel shall be immediately removed from Rockford Park District property, may be subjected to substance abuse testing in keeping with the contractor's/vendor's policy and shall not be assigned to the Rockford Park District under this contract absent assurances that the contractor personnel is no longer under the influence of drugs and/or alcohol.

14. REVISED CLEAN AIR ORDINANCE OVERVIEW

As it is stated, the [CLEAN AIR ORDINANCE](#) prohibits smoking *entirely* at Park District facilities, parks, museums, and any Park District property with the exception of public golf courses where adult smoking is permitted beyond 50 feet of enclosed/partially-enclosed spaces on golf course playing fields, in the company of consenting adults and absent assembly by the general public. Smoking will also be prohibited at select youth-specific golf areas such as Alpine Hills Golf Center and the Learning Links at Ingersoll Golf Course. The ordinance specifies the exclusion of any "lighted or vaporized substance in any manner or form," including cigars, cigarettes, pipes, and e-cigarettes.

15. CLEAN CONSTRUCTION DEMOLITION DEBRIS

All clean construction and demolition debris and uncontaminated soil shall be recycled or reused within the job site if suitable or disposed of in a licensed landfill as allowed by local laws and regulations, State or Federal solid waste disposal laws and regulations and solid waste determinations of the IEPA. The contractor is responsible for the assessment, waste determination profiling, and proper disposal of all excess soil and subsurface materials that are not able to be re-used on the project site as suitable clean fill. Contractor responsibility's shall include all required media sampling, laboratory analysis, disposal profiling fees, transportation, and disposal tipping fees and surcharges.

16. BUILDING AND ZONING CODES

Contractors or vendors should be aware that the Rockford Park District is required by state law to follow and adhere to all city building and zoning codes. Any permits that are needed for the installation of construction of any work included under this contract and which are required by the authorities of the jurisdiction shall be obtained and paid for by the Contractor following those ordinances, regulations, and codes which require the permits. If the authorities of the jurisdiction require inspection at certain times during the installation, the Contractor shall arrange for, and be present at, any such inspection.

17. TRAINING REQUIREMENTS

Compliance with participation in apprenticeship and training programs is defined in the following three areas:

- A. The company must be a member in good standing with an association or union that has the capacity to offer apprenticeship programs that are approved by the Department of Labor (DOL).

GENERAL CONDITIONS FOR ALL BIDS

- B. The company must have employees who have completed a program and have an industry issued, nationally recognized credential that certifies occupational proficiency. A Journeyman's card would represent the employee's successful participation in a program.
- C. The company must have access to an apprenticeship or similar DOL-approved program to allow new employees opportunities to learn the work to be performed on a public works project.

18. FAIR EMPLOYMENT

Bidder's signature on the Bid Offer Form will be construed as acceptance of and willingness to comply with all provisions of the acts of the General Assembly of the State of Illinois relating to wages of laborers, preference to citizens of the United States and residents of the State of Illinois, and discrimination and intimidation of employees. Provisions of said acts are herein incorporated by reference and become a part of this proposal and specifications.

19. ENVIRONMENTALLY PREFERABLE PURCHASING

Environmentally preferable purchasing refers to the procurement of products and services that have the least adverse effect on human health and the environment when compared with competing products or services that serve the same purpose. Products identified as having the least adverse effect on human health and the environment are referred to as environmentally preferable products (EPPs). Bidders able to supply environmentally preferable products that meet performance requirements are encouraged to identify the products in the bid. The RPD prefers to purchase recycled-content products rather than non-recycled products whenever price, quality, and availability are comparable.

20. NON-DISCRIMINATION

In connection with the performance of work under this contract, the contractor agrees not to discriminate against any employee or applicant for employment because of age, race, religion, color, handicap, sex, physical condition, developmental disability, sexual orientation or national origin. This provision shall include, but not be limited to, the following: employment, upgrading, demotion or transfer, recruitment or recruitment of compensation, and selection for training, including apprenticeship. Except with respect to sexual orientation, the contractor further agrees to take affirmative action to ensure Equal Employment Opportunities. The contractor agrees to post in conspicuous places, available for employees and applicants for employment, notices to be provided by the contracting officer setting forth the provisions of the Non-Discrimination Clause.

21. WARRANTY / GUARANTEE

On all "equipment" bid awards, vendor must provide the Rockford Park District with two (2) copies of the warranty/guarantee information.

GENERAL CONDITIONS FOR ALL BIDS

22. NON-BARRED BIDDING

The Bidder is not barred from bidding on this Contract as a result of a conviction for the violation of state laws prohibiting bid rigging or bid rotating.

The Bidder, by signing the Bid Offer Form, acknowledges, understands and abides by all of the above "General Conditions of All Bids".

TERMS AND CONDITIONS OF THIS BID

1. PERFORMANCE AND LABOR AND MATERIAL PAYMENT BONDS

Simultaneously with the delivery of the executed contract, and no more than fourteen (14) calendar days after the Park District issues an award notification, the successful bidder must furnish a 100% Performance and Payment bond for any public work of any kind costing over \$50,000.00, issued by a duly authorized Surety Company authorized to do business in the State of Illinois, and satisfactory to Owner and pursuant to The Public Construction Bond Act 098-0216, (30 ILCS 550/1) (from Ch. 29, par. 15).

The laws of the State of Illinois shall govern the contract awarded to the successful bidder.

The place of the contract will be the County of Winnebago, State of Illinois, whose courts, on the event of a dispute, shall have jurisdiction over the parties.

The bidder who is awarded the contract shall comply with all laws of the United States of America, the State of Illinois, and the cities and villages in which the work is to be performed.

2. CONSTRUCTION SCHEDULE

Upon request bidder shall submit an estimated Construction schedule listing milestone dates and completion dates of major site features.

3. CHANGE ORDERS

For all Change Order additions after contract award, a 6% allowance for profit and overhead shall be allowed over actual cost.

For all Change Order deducts after contract award, 4% over actual cost shall be required as a deduct for unearned profit and overhead.

Unit Bid costs shall have profit and overhead included in the unit cost. All Change Orders employing Unit Bid costs shall be billed at unit costs only with no additional allowance for profit and overhead.

4. PROGRESS PAYMENTS

Based upon Application of Payment submitted to the Owner by the successful bidder; the Owner shall make progress payments on account of the Contract Sum to the successful bidder. All invoices for Prevailing Wage work must be submitted with CERTIFIED PAYROLL RECORDS. The Park District will not pay any invoice for prevailing wage work that does not have appropriate certified payroll records attached. Standard payment terms are net 30 days, upon receipt of application for payment. Lien waivers, for the full contract amount from the prime contractor, and for the respective subcontract amounts from all sub-contractors and material suppliers shall be delivered to the owner prior to, or simultaneously with, the owner's release of payment for the contract work. Payments will be in full upon satisfactory completion of work, unless

TERMS AND CONDITIONS OF THIS BID

otherwise specified. There will be a 10% retainage on progress payments until all punch list items are completed to the Owner's satisfaction.

5. FINAL PAYMENT

The Owner shall make final payment within thirty (30) days after completion of the work, provided the Contract be then fully performed and accepted by the owner's representative.

6. ENUMERATION OF BID DOCUMENTS

The bid documents are as noted in Paragraph #7 of the Terms and Conditions, and are enumerated on the attached sheets (drawings, specifications, etc.)

7. BID DOCUMENTS

The bid package consists of the following: General Conditions; these Terms and Conditions, the drawings, the specifications, and all Addenda issued prior to the bid closing. The successful bidder will be requested to enter into one of two Standard Forms of Agreements used by the Rockford Park District. The agreements are ConsensusDOCS 200, 2012 Edition or one similar to the AIA Documents A107. Both documents are available for inspection at the District Office, 401 South Main Street, Rockford, Illinois, 61101. A current copy of the Illinois Department of Labor Prevailing Wage Rates can be obtained from the following website:

<http://www.illinois.gov/idol/Laws-Rules/CONMED/Pages/Rates.aspx>.

8. STATEMENT OF CONTRACTOR'S QUALIFICATIONS

The Rockford Park District shall have the right to take such steps as it deems necessary to determine the ability of the Bidder to perform the obligations under the Contract, and the bidder shall furnish the Rockford Park District all such information and data as it may request. Bidder shall submit with the bid, a complete subcontractors list on the form included with this bid offer for approval by Owner. If awarded the bid, and Owner has made no objections to the subcontractors, no changes shall be made to the list without prior authorization from the owner. The Rockford Park District reserves the right to reject any bid where an investigation of the available information does not satisfy the Rockford Park District that the Bidder is qualified to carry out properly the term of the Contract.

9. NONDISCRIMINATION PROVISIONS

During the performance of the agreement, the successful bidder will agree as follows:

- A. The Contractor will not discriminate against any employee or applicant for employment because of race, color, religion, sex, or national origin. The Contractor will take affirmative action to ensure that applicants are employed, and that employees are treated during employment without regard to race, color, religion, sex, or national origin. Such action shall include, but not be limited to the following: Employment, upgrading, demotion, or transfer; recruitment or

TERMS AND CONDITIONS OF THIS BID

recruitment advertising, layoff or termination; rates of pay or other compensation; and selection for training, including apprenticeship. The contractor agrees to post in conspicuous places, available to employees and applicants for employment, notices to be provided by the contracting officer setting forth the provision of this nondiscrimination clause.

- B. The contractor will, in all solicitations and advertisements for employees placed by or on behalf of the contractor, state that all qualified applicants will receive consideration for employment without regard to race, color, religion, sex, or national origin.
- C. The contractor will send to each labor union or representative of workers with which he has a collective bargaining agreement or other contract or understanding, a notice, to be provided by the agency contracting officer, advising the labor union or worker's representative of the contractor's commitments under Section 202 of Executive Order No. 11246 of September 24, 1965, and shall post copies of the notice in conspicuous places available to employees and applicants for employment.
- D. The contractor will furnish all information and reports required by Executive Order No. 11246 September 24, 1965, and by the rules, regulations and orders of the Secretary of Labor, or pursuant thereto, and will permit access to the company's books, records and accounts by the contracting agency and the Secretary of Labor for purposes of investigation to ascertain compliance with such rules, regulations and orders.
- E. In the event of the contractor's failure to comply with the Nondiscrimination Clauses of this contract or with any of such rules, regulations or orders, this contract may be cancelled, terminated or suspended in whole or in part and the contractor may be declared ineligible for further government contracts in accordance with procedures authorized in Executive Order No. 11246 of September 24, 1965, and such other sanctions may be imposed and remedies invoked as provided in Executive Order No. 11246 of September 24, 1965, or by rule, regulation or order of the Secretary of Labor, or as otherwise provided for by law.
- F. The contractor will include the provisions of Paragraphs (1) through (7) in every subcontract or purchase order unless exempted by rules, regulations or orders of the Secretary of Labor issued pursuant to Section 204 of Executive No. 11246 of September 24, 1965, so that provisions will be binding upon each subcontractor or vendor. The contractor will take such action with respect to any subcontract or purchase order as the contracting agency may direct as a means of enforcing such provisions including sanctions for noncompliance; Provided, however, that in the event the contractor becomes involved in or is threatened with litigation

TERMS AND CONDITIONS OF THIS BID

with a subcontractor or a vendor as a result of such direction by the contracting agency, the contractor may request the United States to enter into such litigation to protect the interests of the United States.

The obligations contained herein apply to products provided by the Supplier, its subcontractor or any third party involved in the creation of the products to be delivered to the Rockford Park District under this Contract. Failure to comply with any of the obligations contained herein, may result in the Rockford Park District availing itself of all its rights under the law and under this Contract including, but not limited to, its right pertaining to termination or default.

The warranties contained herein are separate and discrete from any other warranties specified in this contract, and are not subject to any disclaimer or warranty or limitation of Supplier's liability which may be specified in this Contract, its appendices, its schedules, its annexes or any document incorporated in this Contract by reference.

The Bidder, by signing the Bid Offer Form, acknowledges, understands and abides by all of the above "Terms and Conditions of All Bids".

INSURANCE REQUIREMENTS

BIDDERS' ATTENTION IS DIRECTED TO THE INSURANCE REQUIREMENTS ATTACHED. IT IS HIGHLY RECOMMENDED THAT THE BIDDER CONFERS WITH ITS RESPECTIVE INSURANCE CARRIERS OR BROKERS TO DETERMINE IN ADVANCE OF BID SUBMISSION THE AVAILABILITY OF INSURANCE CERTIFICATES AND ENDORSEMENTS AS PRESCRIBED AND PROVIDED HEREIN. IF AN APPARENT LOW BIDDER FAILS TO COMPLY STRICTLY WITH THE INSURANCE REQUIREMENTS, THAT BIDDER MAY BE DISQUALIFIED FROM AWARD OF THE CONTRACT.

Contractor shall procure and maintain for the duration of the contract and for as long as the attached requirements say after completion of the contract, insurance against claims for injuries to persons or damages to property which may arise from or in connection with the performance of the work hereunder by the Contractor, its agents, representatives, employees or subcontractors. The cost of such insurance shall be included in the Contractor's bid.

A Certificate of Insurance, with "Additional Insured Endorsement 2010" attached, is required by the Rockford Park District. The Bidder must require its insurance company to list the Rockford Park District as "Additional Insured". In the "Description of Operations/Locations/Vehicles/Special Items" section of the Certificate it must state: "Rockford Park District is additional insured per Additional Insured Endorsement 2010 for services rendered on Rockford Park District properties".

INSURANCE REQUIREMENTS

ROUTINE CONSTRUCTION, MAINTENANCE AND REPAIR PROJECTS

Contractor shall obtain insurance of the types and in the amounts listed below.

1. COMMERCIAL GENERAL AND UMBRELLA LIABILITY INSURANCE

Contractor shall maintain commercial general liability (CGL) and, if necessary, commercial umbrella insurance with a limit of not less than \$1,000,000 each occurrence. If such CGL insurance contains a general aggregate limit, it shall apply separately to this project/location.

CGL insurance shall be written on Insurance Services Office (ISO) occurrence form CG 00 01 10 93, or a substitute form providing equivalent coverage, and shall cover liability arising from premises, operations, independent contractors, products-completed operations, personal injury and advertising injury, and liability assumed under an insured contract (including the tort liability of another assumed in a business contract).

Owner shall be included as an insured under the CGL, using ISO additional insured endorsement CG 20 10 or a substitute providing equivalent coverage, and under the commercial umbrella, if any. This insurance shall apply as primary insurance with respect to any other insurance or self-insurance afforded to Owner.

There shall be no endorsement or modification of the CGL limiting the scope of coverage for liability arising from pollution, explosion, collapse, or underground property damage.

2. CONTINUING COMPLETED OPERATIONS LIABILITY INSURANCE

Contractor shall maintain commercial general liability (CGL) and, if necessary, commercial umbrella liability insurance with a limit of not less than \$1,000,000 each occurrence for at least three years following substantial completion of the work.

Continuing CGL insurance shall be written on ISO occurrence form CG 00 01 10 93, or substitute form providing equivalent coverage, and shall, at minimum, cover liability arising from products-completed operations and liability assumed under an insured contract.

Continuing CGL insurance shall have a products-completed operations aggregate of at least two times its each occurrence limit.

Continuing commercial umbrella coverage, if any, shall include liability coverage for damage to the insured's completed work equivalent to that provided under ISO form CG 00 01.

INSURANCE REQUIREMENTS

3. BUSINESS AUTO AND UMBRELLA LIABILITY INSURANCE

Contractor shall maintain business auto liability and, if necessary, commercial umbrella liability insurance with a limit of not less than \$1,000,000 each accident. Such insurance shall cover liability arising out of any auto including owned, hired and non-owned autos.

Business auto insurance shall be written on Insurance Services Office (ISO) form CA 00 01, CA 00 05, CA 00 12, CA 00 20, or a substitute form providing equivalent liability coverage. If necessary, the policy shall be endorsed to provide contractual liability coverage equivalent to that provided in the 1990 and later editions of CA 00 01.

4. WORKERS COMPENSATION INSURANCE

Contractor shall maintain workers compensation as required by statute and employers liability insurance. The Rockford Park District requires Illinois workers compensation statutory limits.

If Owner has not been included as an insured under the CGL using ISO additional insured endorsement CG 20 10 under the Commercial General and Umbrella Liability Insurance required in this Contract, the Contractor waives all rights against Owner and its officers, officials, employees, volunteers and agents for recovery of damages arising out of or incident to the Contractor's work.

5. GENERAL INSURANCE PROVISIONS

A. Evidence of Insurance

Prior to beginning work, Contractor shall furnish Owner with a certificate(s) of insurance and applicable policy endorsement(s), executed by a duly authorized representative of each insurer, showing compliance with the insurance requirements set forth above.

All certificates shall provide for 30 days written notice to Owner prior to the cancellation or material change of any insurance referred to therein. Written notice to Owner shall be by certified mail, return receipt requested.

Failure of Owner to demand such certificate, endorsement or other evidence of full compliance with these insurance requirements or failure of Owner to identify a deficiency from evidence that is provided shall not be construed as a waiver of Contractor's obligation to maintain such insurance.

Owner shall have the right, but not the obligation, of prohibiting Contractor or any subcontractor from entering the project site until such certificates or other evidence that insurance has been placed in complete compliance with these requirements is received and approved by Owner.

INSURANCE REQUIREMENTS

Failure to maintain the required insurance will result in termination of this Contract at Owner's option.

With respect to insurance maintained after final payment in compliance with a requirement above, an additional certificate(s) evidencing such coverage shall be promptly provided to Owner whenever requested.

Contractor shall provide certified copies of all insurance policies required above within 10 days of Owner's written request for said copies.

B. Acceptability of Insurers

For insurance companies which obtain a rating from A.M. Best, that rating should be no less than A VII using the most recent edition of the A.M. Best's Key Rating Guide. If the Best's rating is less than A VII or a Best's rating is not obtained, the Owner has the right to reject insurance written by an insurer it deems unacceptable.

C. Cross-Liability Coverage

If Contractor's liability policies do not contain the standard ISO separation of insureds provision, or a substantially similar clause, they shall be endorsed to provide cross-liability coverage.

D. Deductibles and Self-Insured Retentions

Any deductibles or self-insured retentions must be declared to the Owner. At the option of the Owner, the Contractor may be asked to eliminate such deductibles or self-insured retentions as respects the Owner, its officers, officials, employees, volunteers and agents or required to procure a bond guaranteeing payment of losses and other related costs including but not limited to investigations, claim administration and defense expenses.

E. Subcontractors

Contractor shall cause each subcontractor employed by Contractor to purchase and maintain insurance of the type specified above. When requested by the Owner, Contractor shall furnish copies of certificates of insurance evidencing coverage for each subcontractor.

6. INDEMNIFICATION

To the fullest extent permitted by law, the Contractor shall indemnify and hold harmless the Owner and the Architect and the officers, officials, employees, volunteers and agents from and against all claims, damages, losses and expenses including but not

INSURANCE REQUIREMENTS

limited to legal fees (attorney's and paralegals' fees and court costs), arising out of or resulting from the performance of the Contractor's work, provided that any such claim, damage, loss or expense (i) is attributable to bodily injury, sickness, disease or death, or injury to or destruction of tangible property, other than the work itself, including the loss of use resulting there from and (ii) is caused in whole or in part by any wrongful or negligent act or omission of the Contractor, any Subcontractor, anyone directly or indirectly employed by any of them or anyone for whose acts any of them may be liable, except to the extent caused in part by a party indemnified hereunder. Such obligation shall not be construed to negate, abridge, or otherwise reduce any other right or obligation of indemnity which would otherwise exist as to any party or person described in this Paragraph. Contractor shall similarly protect, indemnify and hold and save harmless the Owner, its officers, officials, employees, volunteers and agents against and from any and all claims, costs, causes, actions and expenses including but not limited to legal fees, incurred by reason of Contractor's breach of any of its obligations under, or Contractor's default of, any provision of the Contract.

INSURANCE REQUIREMENTS

ORIG. PRINTING
AUGUST 1995

CONTRACTUAL RISK TRANSFER
INSURANCE FORMS

THIS ENDORSEMENT CHANGES THE POLICY. PLEASE READ IT CAREFULLY.

ADDITIONAL INSURED - OWNERS, LESSEES OR CONTRACTORS (FORM B)

This endorsement modifies insurance provided under the following:

COMMERCIAL GENERAL LIABILITY COVERAGE PART

SCHEDULE

Name of Person or Organization:

(If no entry appears above, information required to complete this endorsement will be shown in the Declarations as applicable to this endorsement.)

WHO IS AN INSURED (Section II) is amended to include as an insured the person or organization shown in the Schedule, but only with respect to liability arising out of the ongoing operations performed for that insured.

The General Aggregate Limit under LIMITS OF INSURANCE (SECTION III) applies separately to each project away from premises owned by or rented to the respondent.

CG 20 10 10 93 Copyright, Insurance Services Office, Inc. 1992

XIII.F.3

PROJECT SCHEDULE

Bid packages available to the public	8/28/19
Pre-Bid Conference.....	9/5/19
Bids due	9/19/19
Leadership Team Approval Dates.....	9/23/19 & 9/30/19
Board of Commissioner's Approval	10/8/19
Contract Awarded.....	10/9/19
Award Notifications to Bidders	10/9/19
Collection of Contract Documents.....	10/18/19
Notice to Proceed.....	10/18/19
Construction Start date.....	10/21/19
Demolition, Grading, Paving, Flatwork Complete	11/29/19
Playground & Site Equipment Arrives	4/2020
Substantial Completion	5/1/20
Project Close-out / Completion.....	5/22/20

SPECIFICATIONS

GENERAL SPECIFICATIONS OF THE CONTRACT

The successful bidder will be requested to enter into the Standard Form of Agreements used by the Rockford Park District. An example of the document is available for inspection at the District Office, 401 South Main Street, Rockford, Illinois, 61101.

SECTION 011100 SUMMARY OF WORK

Summary

1. This section includes the following:
 - a. Brief description of scope
 - b. Definitions
 - c. Examination of site conditions
 - d. Summary of Bids
 - e. Work Instructions

Work Scope

The work scope includes site demolition and removals, site grading, storm water drainage installation, asphalt paving, concrete flatwork, playground equipment and surfacing installation, fencing, site furnishings and sports equipment installation, landscaping, and turf establishment.

Definitions

1. Owner shall be the Rockford Park District.
2. Engineer shall be ARC Design Resources.
3. Contractor shall refer to the General Contractor.

Precedence

Contractor is to notify Owner of any ambiguity or contradiction between the plans, specifications, and bid requirements as soon as discovered. The document which requires the greater amount of work, as decided by the Owner, will prevail. The decision of the Owner as to which requirement of the plans or specifications is correct shall be final and conclusive. If the Contractor fails to give notice of such variance, any corrective work required shall be done at Contractor's sole expense.

Effect To Be Given To Every Part Of Contract

The plans, specifications, and other contract documents must be construed together. If the contract does not require certain portions of the work to be performed by the Contractor, that exclusion may include, by implication, other portions of project are

SPECIFICATIONS

within the Contractor's scope of work. Any work or material not shown on the plans or described in the specifications but which may be fairly implied as included in any item of the contract, shall be done and furnished by the Contractor without additional charge.

Examination of Site

1. Bidders shall visit site of proposed work and fully acquaint themselves with the conditions as they exist, so that they may fully understand the facilities, difficulties, and restrictions attending the execution under the contract. Bidders shall also thoroughly examine and be familiar with the contract documents. The failure or omission of any bidder to receive or examine any form, instrument, or to visit the site(s) and acquaint himself with the conditions there existing shall in no way relieve any bidder from any obligation relative to this bid. By submitting a bid, the bidder agrees and warrants that they have examined the site(s) and contract documents, and where the contract documents require in any part of the work a given result to be produced, that the specifications and/or drawings are adequate and the required result can be produced under the specifications and/or drawings.

2. No plea of ignorance of conditions that exist or of conditions or difficulties that may be encountered in the execution of the work under this contract, as a result of failure to make necessary investigations, will be accepted as an excuse for any failure or omission on the part of said Contractor to fulfill in every detail all of the requirements of said contract, specifications, and plans, or will be accepted as basis for any claims whatsoever, for extra compensation. Upon application, all available information in the possession of the Owner will be shown to the bidders, but the correctness of any such information is not guaranteed.

Tree Replacement Fee Schedule

<u>Diameter of Tree Damaged</u>	<u>Fee Amount</u>
4-<6 inches	\$1,350
6-<9 inches	\$2,025
9-<12 inches	\$3,600
12-<18 inches	\$8,100
18-<24 inches	\$14,400
24-<30 inches	\$22,500
30-<36 inches	\$32,400
36-<42 inches	\$44,100
42 inches or greater	\$52,900

SPECIFICATIONS

Summary of Bids

1. Base Bid –
 - a. All construction for base bid work as shown on drawings, specifications and bid form.
 - b. The Park District plans on awarding the Base Bid, which includes both park sites, in its entirety.

2. Alternate Bids – complete additional work per all drawings and specifications
 - a. Alternate Bid #1 – Additional 4' chain link fencing
 - b. Alternate Bid #2 – Additional 8' high chain link
 - c. Alternate Bid #3 – Shade tree plantings

Work Responsibilities

1. Contractor shall provide all labor, materials, supplies, equipment, incidentals and disposal to provide complete construction of all contracted items from the bid, following all specifications and special provisions as bid.

2. Contractor is responsible for all site layout and staking costs. These costs are incidental to the contract.

3. Owner supplied items:
 - a. Playground equipment
 - b. Playground surfacing
 - c. Sports equipment
 - d. Site furnishings

SECTION 012500 SUBSTITUTIONS

1. Substitutions for any items listed in the specifications or indicated on the drawings will be considered. The Contractor must submit the substitution(s), including detailed descriptions, as additional alternates along with their respective price changes. The Contractor must be prepared to complete the work as specified for the base price if the submitted substitution alternate is not accepted. If the Contractor wishes, written approval of a substitution may be obtained before bids are due if the data on the substitution is submitted five (5) days before the bids are due and an addendum is issued upon acceptance of the substitution by the Owner before the bids are due. Items will be considered for substitution after award of the contract, utilizing the change order procedure.

SPECIFICATIONS

SECTION 012600 CONTRACT MODIFICATION PROCEDURES

Summary

1. Section includes administrative and procedural requirements for handling and processing Contract modifications.

Minor Changes in the Work

1. Owner will issue supplemental instructions authorizing minor changes in the Work, not involving adjustment to the Contract Sum or the Contract Time.

Proposal Requests

1. Owner-Initiated Proposal Requests: Owner will issue a detailed description of proposed changes in the Work that may require adjustment to the Contract Sum or the Contract Time. If necessary, the description will include supplemental or revised Drawings and Specifications.
 - a. Proposal Requests issued by Owner are not instructions either to stop work in progress or to execute the proposed change.
 - b. Within time specified in Proposal Request, submit a quotation estimating cost adjustments to the Contract Sum and the Contract Time necessary to execute the change.
 - i. Include a list of quantities of products required or eliminated and unit costs, with total amount of purchases and credits to be made. If requested, furnish survey data to substantiate quantities.
 - ii. Include costs of labor and supervision directly attributable to the change.
 - iii. Include an updated Contractor's construction schedule that indicates the effect of the change, including, but not limited to, changes in activity duration, start and finish times, and activity relationship. Use available total float before requesting an extension of the Contract Time.
2. Contractor-Initiated Proposals: If latent or changed conditions require modifications to the Contract, Contractor may initiate a claim by submitting a request for a change to Owner.
 - a. Include a statement outlining reasons for the change and the effect of the change on the Work. Provide a complete description of the proposed change. Indicate the effect of the proposed change on the Contract Sum and the Contract Time.
 - b. Include a list of quantities of products required or eliminated and unit costs, with total amount of purchases and credits to be made. If requested, furnish survey data to substantiate quantities.

SPECIFICATIONS

- c. Include costs of labor and supervision directly attributable to the change.
- d. Include an updated Contractor's construction schedule that indicates the effect of the change, including, but not limited to, changes in activity duration, start and finish times, and activity relationship. Use available total float before requesting an extension of the Contract Time.

Change Order Procedures

1. On Owner's approval of a Proposal Request, Owner will issue a Change Order for signatures of Owner and Contractor on Rockford Park District Change order form.

SECTION 012900 APPLICATIONS FOR PAYMENT

1. All invoices for Prevailing Wage work must be submitted with certified payroll records. The Park District **will not pay** any invoice for prevailing wage work that does not have appropriate certified payroll records attached.
2. Each Application for Payment shall be consistent with previous applications and payments and paid for by Owner.
 - a. Initial Application for Payment, Application for Payment at time of Substantial Completion, and final Application for Payment involve additional requirements.
3. Payment Application Times: The date for each progress payment is indicated in the Agreement between Owner and Contractor. The period of construction work covered by each Application for Payment is the period indicated in the Agreement.
4. Application for Payment Forms: Use AIA Document G702 and AIA Document G703 as form for Applications for Payment.
5. Application Preparation: Complete every entry on form. Notarize and execute by a person authorized to sign legal documents on behalf of Contractor. Owner may return incomplete applications without action.
 - a. Entries shall match data on the schedule of values and Contractor's construction schedule. Use updated schedules if revisions were made.
 - b. Include amounts of Change Orders issued before last day of construction period covered by application.

SPECIFICATIONS

6. Transmittal: Submit three signed and notarized original copies of each Application for Payment to Owner by a method ensuring receipt within 24 hours. One copy shall include waivers of lien and similar attachments if required.
 - a. Transmit each copy with a transmittal form listing attachments and recording appropriate information about application.

7. Waivers of Mechanic's Lien: With each Application for Payment, submit waivers of mechanic's lien from entities lawfully entitled to file a mechanic's lien arising out of the Contract and related to the Work covered by the payment.
 - a. Submit partial waivers on each item for amount requested in previous application, after deduction for retainage, on each item.
 - b. When an application shows completion of an item, submit conditional final or full waivers.
 - c. Owner reserves the right to designate which entities involved in the Work must submit waivers.
 - d. Waiver Forms: Submit waivers of lien on forms, executed in a manner acceptable to Owner.

8. Initial Application for Payment: Administrative actions and submittals that must precede or coincide with submittal of first Application for Payment include the following:
 - a. List of subcontractors.
 - b. Schedule of values.
 - c. Contractor's construction schedule (preliminary if not final).
 - d. Submittal schedule (preliminary if not final).
 - e. List of Contractor's staff assignments.
 - f. List of Contractor's principal consultants.
 - g. Copies of authorizations and licenses from authorities having jurisdiction for performance of the Work.
 - h. Initial progress report.

9. Final Payment Application: Submit final Application for Payment with releases and supporting documentation not previously submitted and accepted, including, but not limited, to the following:
 - a. Evidence of completion of Project closeout requirements.
 - b. Insurance certificates for products and completed operations where required and proof that taxes, fees, and similar obligations were paid.
 - c. Updated final statement, accounting for final changes to the Contract Sum.
 - d. Conditional final waiver of lien.

SPECIFICATIONS

SECTION 013100 COORDINATION

1. The Contractor will be responsible for the coordination of all work of any and all subcontractors they engages to complete the work
 - a. Coordinate sequencing and scheduling of the work including meetings, schedules, and time commitments. Distribute copies of schedules to Owner.
 - b. Coordinate sequence of activities to accommodate tests and inspections.
 - c. Coordinate access and staging area with Owner before commencing any activities on site.

2. Construction Site Access and Limits
 - a. Site access and construction activity is to be limited to the areas shown on the drawings.
 - b. Any damaged areas outside of the construction limits will be restored to the satisfaction of the Owner at Contractor's expense.

3. Schedule work to cause least disruption to Owner's facility operations.
 - a. Situations in which work by Contractor does conflict with Owner's facility operations, preference shall be given to the Owner's facility. Construction costs which may result from such conflicts shall be the responsibility of the Contractor.
 - b. Programs will continue at Washington Park Community Center throughout construction.

4. Contact JULIE and other appropriate entities to verify utility locations before any site work commences. Contractor to verify all above and below grade utilities. Utilities, services, and site improvements damaged during construction shall be repaired or replaced with materials of similar quality at the discretion and to the satisfaction of the Owner at Contractor's expense.

SECTION 013119 PROJECT MEETINGS

1. A pre-construction conference shall be held on the job site selected by Owner as soon as possible after the Contractor gives notice of the starting date and before any of the work commences. Conference shall include Contractor, sub-Contractors, and Owner's representative. Meeting shall be arranged by Contractor with approval of meeting time and place by Owner. Contractor shall provide names of project manager and site superintendent at this time.

SPECIFICATIONS

2. Progress meetings shall be held on a regular weekly basis (or more frequently as required), time and place to be established by Contractor upon consultation and approval of Owner. Contractor shall provide updated schedule at the weekly meetings.

SECTION 013200 PROGRESS SCHEDULES

1. As soon as possible upon award of the contract and before the work begins the Contractor is to submit a complete progress schedule outlining the time periods during which all aspects of the job are to be started and completed.
2. Updated progress schedules shall be prepared by Contractor and submitted to Owner on a weekly basis. Schedule updates shall be submitted on Friday each week during project from start of work until submission of final documentation and invoice unless such requirement is waived or altered during the pre-construction meeting.

SECTION 013300 PRE WORK SUBMITTALS, PRODUCT DATA

1. Before commencing with the work submit to the Owner the following documents:
 - a. Complete Schedule of Values.
 - b. Updated subcontractors list.
 - c. Construction schedule.
 - d. The following product submittals and any other product submittals or mix specifications required by drawings or specifications.
 - i. HMA mix design
 - ii. Concrete mix design
 - iii. Pavement striping paint
 - iv. Fencing
 - v. Erosion control materials
 - vi. Seed mixes

SECTION 013523 OWNER SAFETY REQUIREMENTS

1. The Owner's immediate goal is for Contractors to work injury and illness free on each of the projects they perform at the Rockford Park District. Our goal is zero accidents on construction projects.
2. The Contractor shall comply with applicable provisions of federal, state, and municipal safety laws and building codes. This document outlines contractual requirements and the roles and responsibilities the General Contractor has for construction safety, and outlines minimum safe work requirements. This document, however, does not relieve any Contractor of its obligations to (1)

SPECIFICATIONS

control the means and methods by which it and its employees, subcontractor / trade Contractors and agents perform work or services on this project; (2) independently ascertain what health and safety practices are appropriate and necessary for the performance of such Work; and (3) develop, implement and enforce a comprehensive health and safety program appropriate for the work or services performed that complies with all rules, regulations and industry standards, including permits, governing the Contractor and the Project.

3. In various places, this document requires Contractors to develop and administer plans for safety, and other environmental, health and safety issues on this Project. The Owner shall have the right, but not the obligation, to review and comment on any such plan and any amendments to it. The Contractor shall carefully consider all Owner comments on the Plan, but the Contractor bears final responsibility for scope, detail, implementation, enforcement and administration of all such plans. Neither any comments offered by the Owner nor the failure of the Owner to offer any comments shall in any way reduce the Contractor's responsibility for safety.
4. The Owner has established requirements pertaining to Contractor safety. The Owner requires an EMR of 1.0 or less and may also evaluate other safety performance criteria. For this project, a designated project safety manager shall be on site at all times while work is being performed. The designated project safety representative shall have completed an authorized OSHA Construction Safety Course and have current CPR/First Aid Training from a nationally recognized program. This employee may also function as a superintendent, foreman or crew leader on the Project.
5. The general Contractor must identify their onsite project safety representative prior to the commencement of any work and provide evidence to the Owner this employee meets the minimum requirement listed above. No work is to be performed on site when a project safety representative is not present. The general Contractor/construction manager shall provide notification to Owner of any changes in the designation of a project safety representative.
6. The General Contractor shall have a written safety plan which shall include the following elements as a minimum, and shall train all workmen on the site regarding the plan.
 - a. Accountability-An accountability plan shall be developed, communicated, and implemented for the project.

SPECIFICATIONS

- b. Cell Phone Usage-The general Contractor shall have a cell phone policy with an objective of prohibiting jobsite cell phone usage except as necessary for the performance of work tasks. At a minimum, the policy shall address the following:
 - i. Designated “safe zones” for general use of cell phones by workers
 - ii. A “No Walking While Talking” policy for work task related cell phone usage
 - iii. The site cell phone policy shall be prominently posted at the work site.
- c. Equipment Safety/Fall Protection-The general Contractor shall have a process in place for validating training and certification, if required, for all workers using construction equipment such as cranes, hoists, aerial lifts, mass climbing devices, scaffolding, mobile equipment and specialty equipment. Establish the use of a tagging system for equipment required to be inspected on a daily basis (such as scaffolding, or cranes) to allow workers to verify that the equipment has been inspected and is approved or not approved for use. Protection against falls shall be implemented. Fall arresting systems including lifelines, body harnesses, and other like equipment can be used when fall hazards cannot be addressed by employing railings, temporary floors, nets, and other means. The general Contractor/construction manager can reduce the safety risks associated with performance of elevated work by developing, implementing, and enforcing an effective fall protection safety program that complies with rules, regulations and industry standards addressing fall protection, and includes establishing a fall protection rule not to exceed six (6) feet for the project that includes all elevated work operations. Monitors are not acceptable in lieu of fall protection.
- d. Protection of the Public-The work area will be closed to the public during construction. The general Contractor should take all necessary precautions to prevent injury to the general public. For example, the entire project site should be secured against unauthorized access and provided with appropriate warning signage. Special attention shall also be given to developing adequate means to protect against wind-blown debris and construction-related materials.

SECTION 013543 ENVIRONMENTAL PROCEDURES

- 1. All clean construction and demolition debris shall be recycled or reused within the job site if suitable or disposed of in a licensed landfill as allowed by local laws and regulations, State or Federal solid waste disposal laws and regulations and solid waste determinations of the IEPA. The Contractor is responsible for the

SPECIFICATIONS

assessment, waste determination profiling, and proper disposal of all excess soil and subsurface materials that are not able to be re-used on the project site as suitable clean fill.

2. Contractor responsibility's shall include all required media sampling, laboratory analysis, disposal profiling fees, transportation, and disposal tipping fees and surcharges.

SECTION 014219 REFERENCE STANDARDS

1. Applicability of Standards: Unless the Contract Documents include more stringent requirements, applicable construction industry standards have the same force and effect, to the extent referenced, as if bound or copied directly into the Contract Documents. Such standards are made a part of the Contract Documents by reference.
2. Conflicting Requirements. Where compliance with two or more standards is specified and the standards establish different or conflicting requirements for minimum quantity or quality, comply with the most stringent requirement. Immediately refer uncertainties, and requirements that are different but apparently equal, to the Owner in writing for a decision before proceeding.
3. Copies of Standards: Each entity engaged in construction on project must be familiar with industry standards applicable to its construction activity. Copies of applicable standards are not bound with the contract documents.
 - a. Where copies of standards are needed to perform a required construction activity, obtain copies directly from publication source and make them available upon request.

SECTION 014500 CONTRACT QUALITY CONTROL

1. Deliver all material in manufacturer's original packaging with labels, seals and identification intact. Meet or exceed all listed agency requirements and manufacturers production association recommendations.
2. All adjacent materials are to be from the same material run to protect against adjacent variations in material.
3. The Contractor and manufacturers utilized shall guarantee that all materials will be of first class quality and are guaranteed against any and all defects in material and workmanship.

SPECIFICATIONS

4. All materials and products used in the work for this project shall be selected and installed in strict accordance with the manufacturer's published recommendations/instructions (including manufacturers and producers association recommendations/instructions, if such recommendations/instructions are in existence). A copy of these recommendations/instructions is to be delivered to the Owner before the work begins.
5. The work shall be performed by a knowledgeable Contractor employing only well trained, experienced workmen familiar with the work being performed and all codes pertaining thereto.
6. All of the work performed under this contract shall conform to all of the applicable standards, codes, statutes, etc. of all governing authorities, agencies, utilities, etc. having jurisdiction. To the best of the Owner's knowledge, the work of this project is designed so that it can be performed in conformance with all such requirements. If it is discovered that the requirements of any aspect of the work as indicated prohibits compliance with such requirements the Owner shall be consulted for resolution prior to continuing the work.

SECTION 015000 CONSTRUCTION FACILITIES

1. Contractor shall make provisions for electricity, water, heating, and sanitary facilities at the job site for the duration of the contract and such costs shall be incidental to the contract. Contractor shall insure that the Owner's daily operation of the facilities shall be interrupted as little as possible. Any total interruption of the operations will not be permitted without written consent of the Owner.
2. Protect existing trees and lawn prior to and for duration of project.
 - a. Restore all turf areas damaged by construction activities.
 - b. Replace any trees or plants damaged by construction activities.
3. All open trenches shall be closed and back-filled the same day; no open trenches or partially-filled trenches shall be left over-night. It is the responsibility of the Contractor to protect open trenches from access by unauthorized persons.

SECTION 015633 SECURITY

1. The security of the Owner's site shall not be compromised by the work of this contract and/or the actions of this Contractor and their forces or by the actions of any subcontractor and their forces.

SPECIFICATIONS

2. The Contractor shall erect and maintain all temporary barriers and enclosures required to maintain the security of the Owner's site. The Contractor shall provide temporary chain link (6' height) fencing at the perimeter of the work area. Provide gates with locks as necessary for site access. The Contractor will be responsible for rough mowing of turf areas within and directly outside of the temporary fencing.
3. The costs for site security shall be incidental to the contract.

SECTION 017400 CLEANING AND WASTE MANAGEMENT

1. The Contractor shall regularly remove debris and waste materials at the worksite and roadways resulting from the work. Prior to discontinuing work in an area, the Contractor shall clean the area and remove all rubbish and its construction equipment, tools, machinery, waste, and surplus materials. The Contractor shall minimize and confine dust and debris resulting from construction activities. At the completion of the work, the Contractor shall immediately remove all equipment, tools, surplus materials, waste materials and debris.
2. If the Contractor fails to commence compliance with cleanup duties within two business days after written notification from the Owner of non-compliance, the Owner may implement appropriate cleanup measures without further notice and shall deduct reasonable costs from any amount due or to become due the Contractor.
3. Unless specified differently elsewhere, the Contractor shall leave the premises and walks broom clean, and the surrounding site areas free of any and all construction material and items.

SECTION 017600 PROTECTION OF EXISTING AND INSTALLED WORK

1. Any damage done to any part of Owner's existing building, site, facilities, landscaping, furnishings, and equipment, etc... shall be repaired by the Contractor, to the Owner's satisfaction, at no additional cost to the Owner.

SECTION 017700 CONTRACT CLOSEOUT

1. Submit letters of warranty for labor and manufacturer warranties for materials.
2. Submit copies of all permits.
3. Submit final payment request to Owner's accounts payable with reference to Owner's purchase order or account number and Owner's Project Manager's name.
4. Warranties

SPECIFICATIONS

- a. Contractor shall warranty all labor and workmanship for not less than one year following the date of substantial completion unless otherwise specified.

SECTION 017836 WARRANTIES AND BONDS

1. The Contractor shall provide the Owner with written guarantee stating that all items provided by and all work performed by the Contractor and their suppliers and subcontractors shall remain free from defects in material and workmanship for a minimum period of one year (longer if so stated elsewhere) from date of issuance of final written acceptance of the job, and that all damage resulting from failure to provide above stated performance shall be repaired to the satisfaction of the Owner. Contractor shall pay for all costs incurred in this procedure.

SECTION 017839 PROJECT RECORD DOCUMENTS

1. Contractor shall keep at the job site a copy of the drawings and specifications for the work. The Contractor shall indicate on these items any and all changes with respect to the work of the project as finally installed. These documents shall be known as the As-Built Record Documents and shall be turned over to the Owner upon completion of the project.

SECTION 024113 SELECTIVE DEMOLITION

1. Except for items or materials indicated to be salvaged and to remain on Owner's property, demolished materials shall become Contractor's property and shall be promptly removed from project site; do not allow demolished materials to accumulate on-site. Costs associated with demolition are the responsibility of the Contractor.
2. Pre-demolition photographs or videotape: show existing conditions of adjoining construction and site improvements, including finish surfaces that might be misconstrued as damage caused by selective demolition operations. Submit before work begins.

SECTION 116813 PLAYGROUND EQUIPMENT AND STRUCTURES

1. The playground equipment will be furnished by the Owner. The equipment will be delivered to the site and is to be offloaded by the Contractor. Equipment is to be stored in secure container provided by the Owner.
2. Install playground equipment in accordance with manufacturer's installation instructions.

SPECIFICATIONS

- a. Contact Owner's Representative to approve layout before installation.
 - b. Plans show approximate location of equipment. Owner may make slight adjustments to equipment layout configuration.
 - c. Once equipment is installed, place mark on all equipment support posts to mark final compressed fill height of Engineered Wood Fiber to assist with future maintenance of playground surface.
3. Installation of equipment will be considered complete after inspection and passing a Playground Safety Audit performed by Rockford Park District staff CPSIs (Certified Playground Safety Inspectors). Contractor to remedy all non-equipment manufacturer responsible safety issues found in the audit.
 4. Contractor is responsible for coordination with manufacturer to remedy all manufacturer defects and safety issues, and all associated expenses.

SECTION 321816.13 PLAYGROUND PROTECTIVE SURFACING

Engineered Wood Fiber

1. Engineered wood fiber playground surfacing to be provided by the Owner.
2. Install Engineered Wood Fiber Playground Surfacing in accordance with ASTM F 1292 Standard Specification for Impact Attenuation for Surface Systems Under and Around Playground Equipment and ASTM F 2075 Standard Specification for Engineered Wood Fiber for Use as a Playground Safety Surface Under and Around Playground Equipment.
 - a. Provide nonwoven needle-punched geotextile, specifically manufactured as a drainage geotextile, over excavated and compacted base of playground area before installation of Engineered Wood Fiber.
 - b. Install Engineered Wood Fiber surfacing in 4" compacted lifts until a total depth of 12" is achieved.

SECTION 329200 TURF AND SOIL

General

1. Renovate existing lawn damaged by Contractor's operations, such as storage of materials or equipment and movement of vehicles. Reestablish lawn where settlement or washouts occur or where minor regrading is required by seeding.
2. Submit supplier and product information for seed mix and fertilizer prior to ordering seed and materials or commencing any seeding work.
3. Refer to the SWPPP for turf restoration areas.

SPECIFICATIONS

4. Notify Owner of seeding schedule. Owner shall be on-site to verify seed variety before installation and to obtain product tags. Provide at least two business days notification to Owner.
5. Seed mix to be IDOT Class 1B.
6. There shall be a minimum of four inches (4") of topsoil suitable for turf growth in all areas to be seeded. Areas not capable of growing turf shall receive topsoil and other amendments as necessary.
7. Rough and fine grade areas removing existing vegetation, construction debris, and stones larger than one-inch in diameter to create a smooth surface in preparation of seeding. The area should slope so as to not create any areas of ponding.
8. Apply a starter fertilizer which contains quick and slow release nitrogen immediately prior to seeding area. Fertilizer is to be 18-25-12, or approved equal, applied at a rate of one (1) pound of phosphorus per 1,000 square feet. Apply a second fertilizing with a phosphorus free fertilizer, 15-0-15 or similar, at the rate of one (1) pound per 1,000 square feet one month after germination to give a boost to turf during the establishment period.
9. Seed shall be seeded at a rate of no less than 7 pounds per 1,000 square feet.
10. Seed shall be sown with a machine that mechanically places the seed into the top 1/8 inch of topsoil, packs, and covers the seed in one continuous operation.
11. Straw Mulch Crimping. After seeding straw mulch shall be crimped or punched into the soil to a depth of two (2) inches to four (4) inches using a mulch tool or a dull, serrated farm disk that is set straight. Crimping shall not cut the mulch. This method shall be used in flat areas and on slopes no steeper than 3H:1V and only where equipment can be operated safely. Machinery shall be operated on the contour. Straw mulch material shall be applied at a rate of 90 lbs. per 1,000 square feet.

Performance

1. All seeding areas will be considered 75% complete for payment after all seed and erosion control structures, if applicable, have been installed.
 - a. Contractor is responsible for maintenance of turf areas by fertilizing, weeding, mowing, replanting, and other operations as necessary after

SPECIFICATIONS

germination for two mowings. Mow lawn as soon as top growth is tall enough to cut. Repeat mowing to maintain 2-3 inches height without cutting more than one-third of grass height. Remove no more than one-third of grass-leaf growth in initial or subsequent mowings. Do not delay mowing until grass blades bend over and become matted. Do not mow when grass is wet. During this time there shall be a minimum of one fertilizer application which, as stated above. Site will be assessed for uniform coverage during this period.

- b. An acceptable lawn is a healthy, uniform stand, free of weeds and surface irregularities, with coverage exceeding 90 percent over any 10 sq. ft. and bare spots not exceeding 6 by 6 inches. Reestablish lawns that do not comply with these requirements and continue maintenance (including mowing) until lawns are satisfactory. Work will be considered 100% complete for payment after completion of second mowing, successful lawn reestablishment as needed, and acceptance of turf by the Owner.
2. Notify Owner before second mowing to assess turf areas for compliance with performance requirements. Maintenance of turf areas will be the responsibility of the contractor up to the date of notification.

DuMor 138-6PL (6' bench)

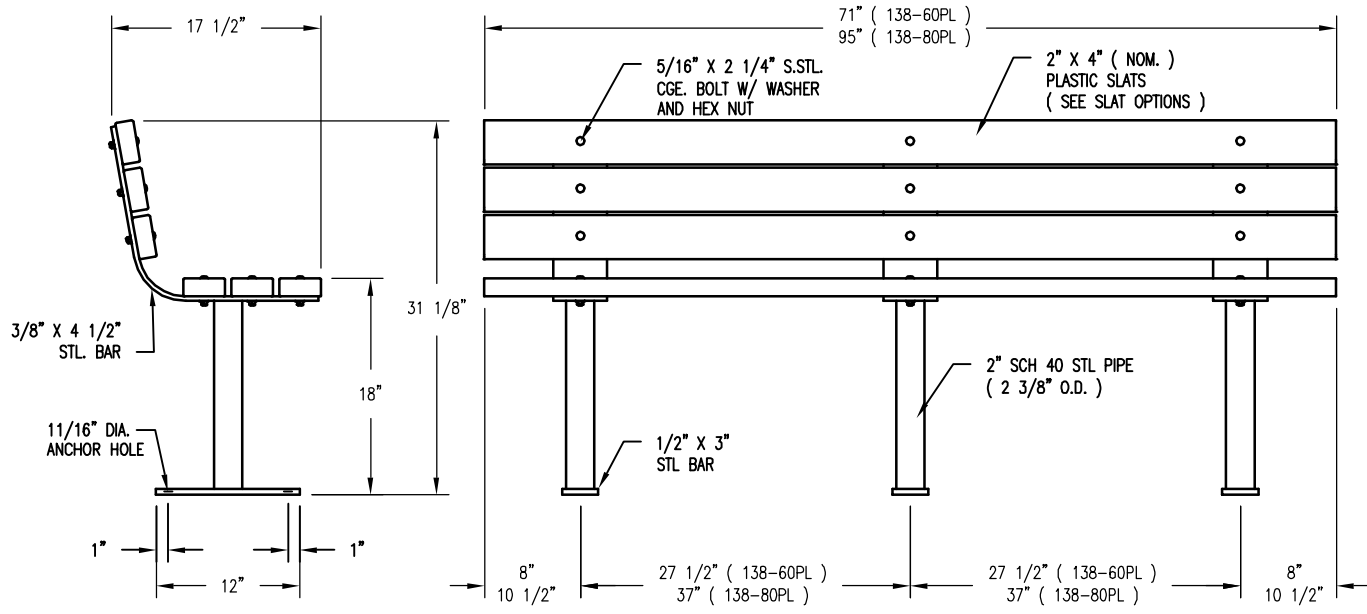

S-2 SURFACE MT

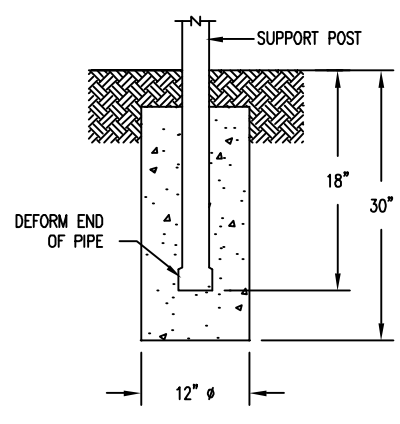

S-1 EMBEDMENT

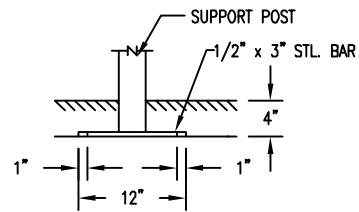

S-4 SUB FLOOR

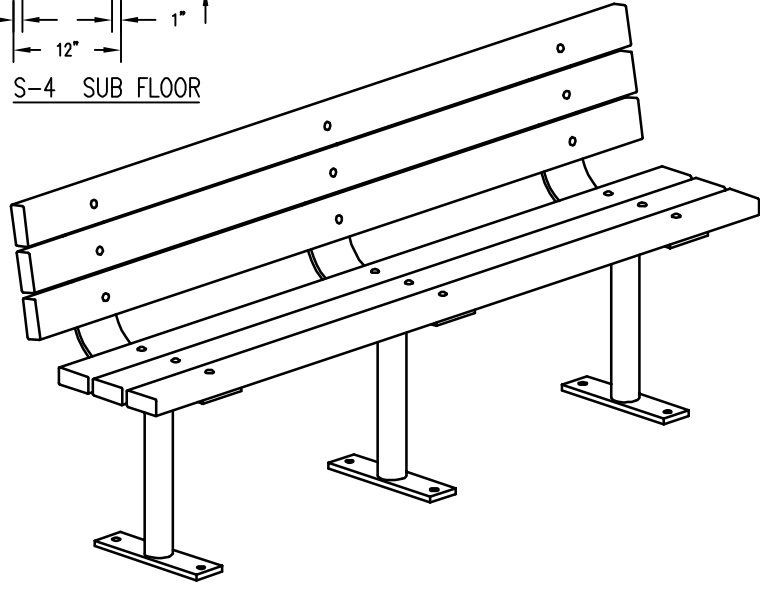

LENGTH OPTIONS

- 6' BENCH
- 8' BENCH

SLAT OPTIONS

- "CEDAR" RECYCLED PLASTIC
- "GREY" RECYCLED PLASTIC
- "REDWOOD" RECYCLED PLASTIC
- "WALNUT" RECYCLED PLASTIC
- OTHER _____

NOTES

- 1.) ALL STL. MEMBERS COATED W/ ZINC RICH EPOXY THEN FINISHED W/ POLYESTER POWDER COATING.
- 2.) 1/2" X 3 3/4" EXPANSION ANCHOR BOLT PROVIDED FOR S-2 & S-4 OPTIONS.

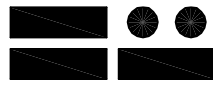
 DuMor, inc. P.O. Box 142 Mifflintown, PA 17059-0142	SCALE :	NONE	TITLE :		BENCH	
	DATE DRAWN :	9/20/01	REV.	DRAWING NUMBER	138 SERIES PL	
	DRAWN BY :	AWH	C	SHEET	1 OF 2	
	DATE REV. :	10/25/11				
REV. BY :	RDH					

SURFACE MOUNT
S-2 OPTION SHOWN

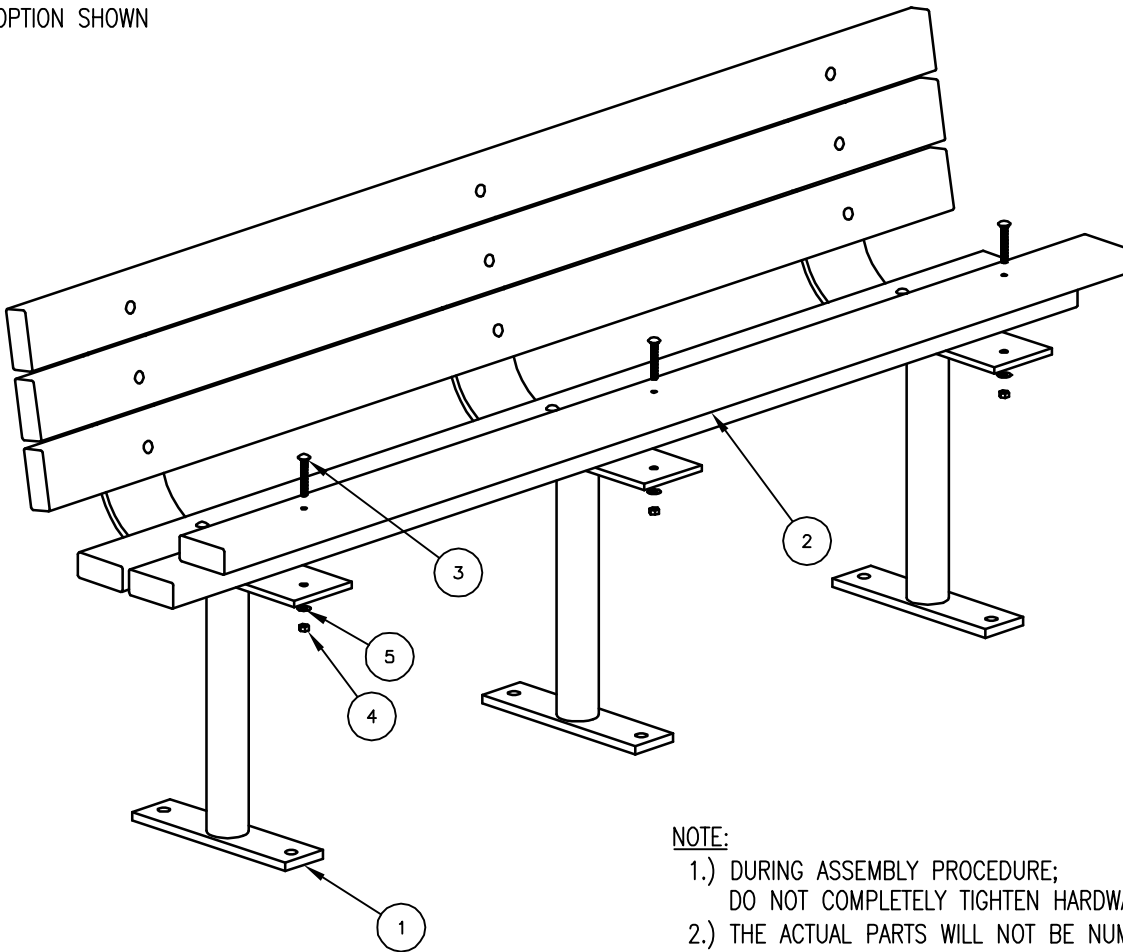

NOTE:

- 1.) DURING ASSEMBLY PROCEDURE;
DO NOT COMPLETELY TIGHTEN HARDWARE.
- 2.) THE ACTUAL PARTS WILL NOT BE NUMBERED:
NUMBERS ONLY APPLY TO DRAWING.
- 3.) SEE SPEC. SHEET 1 FOR MOUNTING OPTIONS.

STEP 1:

USE 3 - PC. SUPPORT POST (1)
 18 - PCS. 5/16" X 2 1/4" SS CGE BOLT (3)
 18 - PCS. 5/16" SS HEX NUT (4)
 18 - PCS. 5/16" SS FLAT WASHER (5)
 6 - PC. 2" X 4" X 71" PLASTIC SLAT (2)
 ATTACH ONE PLASTIC SLAT (2) TO THREE SUPPORT POSTS (1)
 USING HARDWARE (3, 4 & 5). TIGHTEN TO SNUG FIT. REPEAT
 UNTIL ALL PLASTIC SLATS ARE ATTACHED TO SUPPORT POSTS.

STEP 2:

UPON COMPLETION OF BENCH ASSEMBLY SQUARE ALL COMPONENTS
 THEN TIGHTEN ALL HARDWARE.

STEP 3:

ANCHOR ACCORDING TO SUPPORT OPTION USED.

ITEM	QTY	PART NO	DESCRIPTION
1	3	0-138-01/S-2	SUPPORT FOR SURFACE MOUNT
2	6	0-138-60PL-02	2" X 4" X 71" RECYCLED PLASTIC SLAT
3	18	1-11-062	5/16" X 2 1/4" SS CGE BOLT
4	18	1-21-015	5/16" SS HEX NUT
5	18	1-22-017	5/16" SS FLAT WASHER

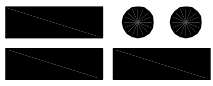
 DuMor, inc. P.O. Box 142 Mifflintown, PA 17059-0142	SCALE :	NONE	TITLE : BENCH ASSEMBLY	
	DATE DRAWN :	9/20/01		
	DRAWN BY :	AWH	REV. :	DRAWING NUMBER 138 SERIES PL
	DATE REV. :	10/25/11	C	
REV. BY :	RDH			

Wabash Valley SG430P (10' bench)

model no:

SG400D, SG400P, SG403D, SG403P, SG406D,
SG406P, SG412D, SG412P, SG415D, SG415P,
SG418D, SG418P, SG424D, SG424P, SG427D,
SG427P, SG430D, SG430P, SG436D, SG436P,
SG439D, SG439P, SG442D, SG442P



WABASH VALLEY

SIGNATURE SERIES

6', 8', 10' & 15' PLAYER BENCH WITH BACK, EXPANDED METAL
& PERFORATED, PORTABLE, INGROUND & SURFACE MOUNT

© Wabash Valley Manufacturing, Inc.

customer service:

ASSEMBLERS: If you find any parts missing or damaged, or if you're having difficulty assembling your furniture/equipment, call us at:

* Before calling, have your product model number available.

1-800-253-8619 (Inside U.S.A.)

260-352-2102 (Outside U.S.A.)

Monday thru Friday,
8:00 AM - 4:30 PM Eastern Time
(EXCEPT HOLIDAYS)

Any correspondence concerning our product should be sent directly to our Customer Service Manager at:

Wabash Valley Manufacturing, Inc.
505 E. Main Street
P.O.Box 5
Silver Lake, IN 46982 U.S.A.
FAX: 260-352-2160

maintenance:

Regular inspection and maintenance of all parts, and fasteners is necessary. Tighten all bolts and nuts. Inspect Tops, Seats, Legs, Braces and Fasteners periodically for wear or vandalism. Replace broken or worn parts immediately or take equipment out of service until repairs are made. Use genuine Wabash Valley replacement parts.

To restore plastisol coating to its luster after prolonged use, wash/rinse/dry and use Armor-All ® or similiar quality vinyl protectant.

KEEP THIS ASSEMBLY/SPECIFICATION SHEET FOR FUTURE REFERENCE.

specifications:

NOTE: We reserve the right to change specifications without notice.

Heat fused poly-vinyl coating, finished on inner-metal structure, to an approximate 3/16" thickness. Framework assemblies are finished with powder coating; electrostatically applied and oven cured according to powder manufacturer's specifications. Fasteners are stainless steel to resist corrosion.

BENCH FRAME:

Main supports are constructed of 2 3/8" od x 12 gage structural steel tubing. Braces are 1" od x 15 gage structural steel tubing. Mounting brackets on legs are 1/4" x 2" steel flat bar or 10 gage sheet metal. Base plates are 1/4" plate steel.

SEATS:

Seats and backs use 3/4" #9 expanded steel mesh and 12 gage sheet metal for the perforated. Framing consist of die formed 10 gage mitred angles 3/4" x 1 3/4". Center brace and mounting brackets are 1/4" x 1 1/2" steel flat bar.

GENERAL:

6' bench ground space requirements for the inground and surface mount are 23 1/8" x 72 3/8". The portable is 23 3/16" x 72 3/8". Seats are 15 3/8" wide x 72 3/8" long, 19" to the top of seat and 35 1/8" to the top of the bench. Corner radius is 3" to the outside.

8' bench ground space requirements for the inground and surface mount are 23 1/8" x 96 3/8". The portable is 23 3/16" x 96 3/8". Seats are 15 3/8" wide x 96 3/8" long, 19" to the top of the seat and 35 1/8" to the top of the bench. Corner radius is 3" to the outside.

10' bench ground space requirements for the inground and surface mount are 23 1/8" x 120 3/8". The portable is 23 3/16" x 120 3/8". Seats are 15 3/8" wide x 120 3/8" long, 19" to the top of the seat and 35 1/8" to the top of the bench. Corner radius is 3" to the outside.

15' bench ground space requirements for the inground and surface mount are 23 1/8" X 180". The portable, is 23 3/16" x 180". Seats are 15 3/8" wide x 180" long, 19" to the top of the seat and 35 1/8" to the top of the bench. Corner radius is 3" to the outside.

parts identification:

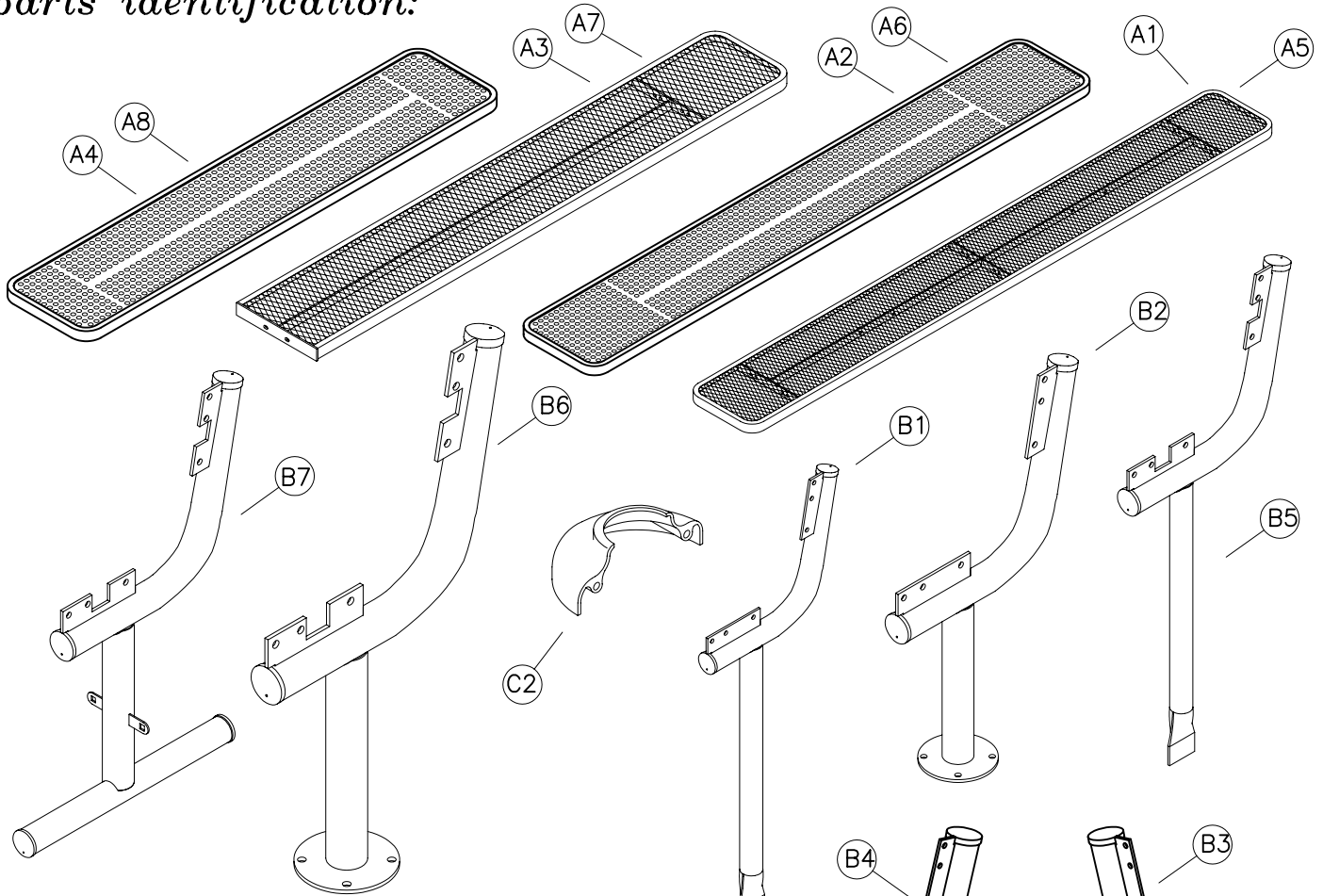

ITEM	PART#	DESCRIPTION	QTY
A1	7558	10' EXPANDED METAL PLAYER	2
A2	7559	8' EXPANDED METAL PLAYER	2
A3	7560	7 1/2' EXPANDED METAL PLAYER	4
A4	7561	6' EXPANDED METAL PLAYER	2
A5	8002	10' PERFORATED PLAYER	2
A6	8003	8' PERFORATED PLAYER	2
A7	8004	7 1/2' PERFORATED PLAYER	4
A8	8005	6' PERFORATED PLAYER	2
B1	7345	INGROUND LEG	2
B2	7346	SURFACE MOUNT LEG	2
B3	7347	RIGHT PORTABLE LEG	1
B4	7348	LEFT PORTABLE LEG	1
B5	7373	10' & 15' INGROUND CENTER LEG	1
B6	7374	10' & 15' SURFACE MOUNT CENTER LEG	1
B7	7375	10' & 15' PORTABLE CENTER LEG	1
C1	7388	PLAYER BRACE	2 OR 4
C2	7120	MOUNTING PLATE COVERS (OPTIONAL)	2 OR 3

hardware identification:

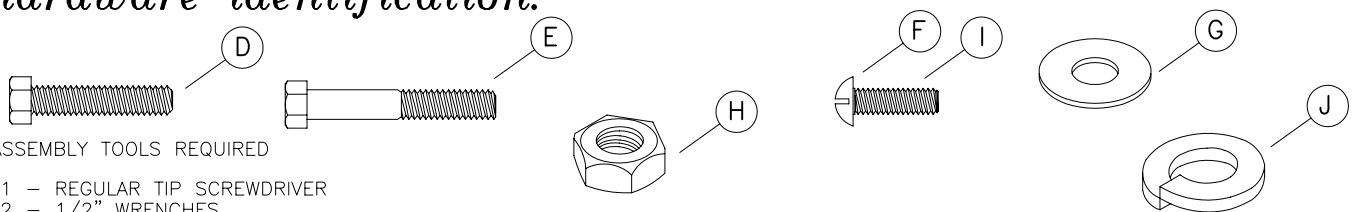

ASSEMBLY TOOLS REQUIRED

- 1 - REGULAR TIP SCREWDRIVER
- 2 - 1/2" WRENCHES
- 1 - 3' OR 6' LEVEL

ITEMS INCLUDED IN HARDWARE PACKAGE #:

ITEM	PART#	DESCRIPTION	21012	21013	21017	21076	21077	21101
			QTY	QTY	QTY	QTY	QTY	QTY
D	17011	5/16-18 x 1 1/2" HEX HEAD BOLT - SS	8	10	2	8	2	0
E	17012	5/16-18 x 2" HEX HEAD BOLT - SS	0	0	4	0	4	0
F	17088	5/16-18 x 1" TRUSS HD MACHINE SCREW - SS	0	2	2	0	2	0
G	17028	3/8" FLAT WASHER - SS	16	24	16	16	16	0
H	17032	5/16-18 HEX FINISH NUT - SS	8	12	8	8	8	0
I	17052	1/4-20 x 1" MACHINE SCREW - SS	0	0	0	0	0	2
J	17050	5/16" SPLIT LOCK WASHER - SS	8	12	8	8	8	0

assembly procedures: IMPORTANT: Assemblers should be reasonably skilled in the assembly of commercial grade/heavy duty fabricated steel equipment.

To ensure proper assembly, it is suggested that you take adequate time to locate and identify each part. To prevent scratching of the finished pieces, we recommend this unit to be assembled on a clean, flat, solid, surface with a drop cloth, allowing plenty of working room. Also please read the instructions and study the sketches very carefully. A little extra time spent before assembly will be well worth it in performing a complete, proper assembly. Please note that all parts have been pre-cut and pre-drilled.

During the assembly process leave all bolts and nuts "finger tight", until the entire unit is completely assembled. This allows room for movement to level or adjust all seats, tops, benches, framework and braces if necessary. **After final adjustment and leveling, permanently tighten all nuts, bolts and fasteners.**

PORTABLE

STEP 1

Invert the (A-) seat so its upside down on an elevated surface. Attach both (B3) and (B4) legs to the outermost part of the seats mounting brackets, see FIG. 1 for 10' and 15' bench attach (B7) center leg to the right side of seat's mounting bracket, see FIG. 2. Use two (D) and (H) with two (G) and one (J) per (D) on all legs except 15' center leg. Join the (A3) seats at squared ends with center leg and use two (E) and (H) with two (G) and one (J) per (E). NOTE: Center leg has mounting brackets offset approximately 1/2".

STEP 2

Attach one end of a (C) brace to (B3) tab and one end of the brace to (B7) tab, see FIG. 1 and 2. Use one (F) and (H) using two (G) and one (J) per (F). Attach opposite ends of the fore mentioned brace to the center brace on the seat. Use one (D) and (H) using two (G) and one (J) per (D). Repeat STEP 2 for the other end of seat with (B4) and (B7).

STEP 3

Rotate bench to the upright position. Attach the second seat (A-) to the outermost part of the bench's back mounting brackets, see FIG. 3. Use two per each mounting bracket (D) and (H) using two (G) and one (J) per (D). For 15' bench use two (E) and (H) using two (G) and one (J) per (E).

FIG. 1

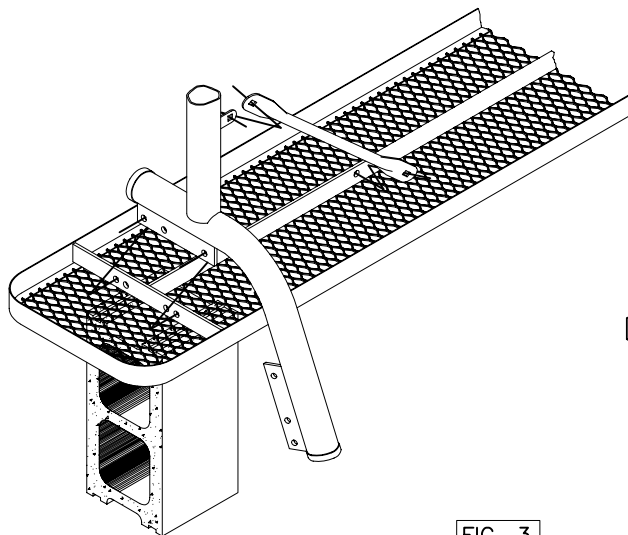

FIG. 2

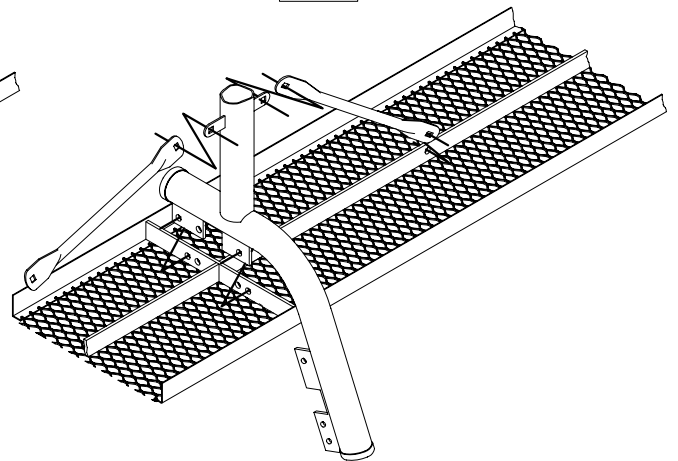
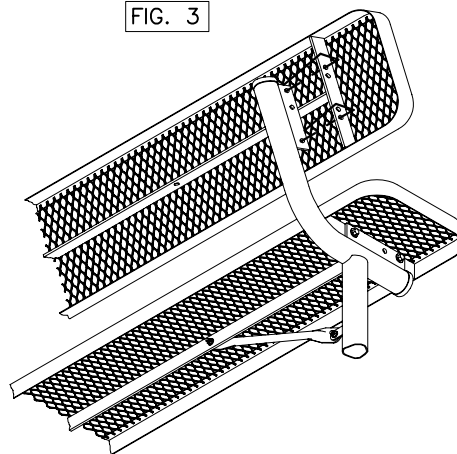
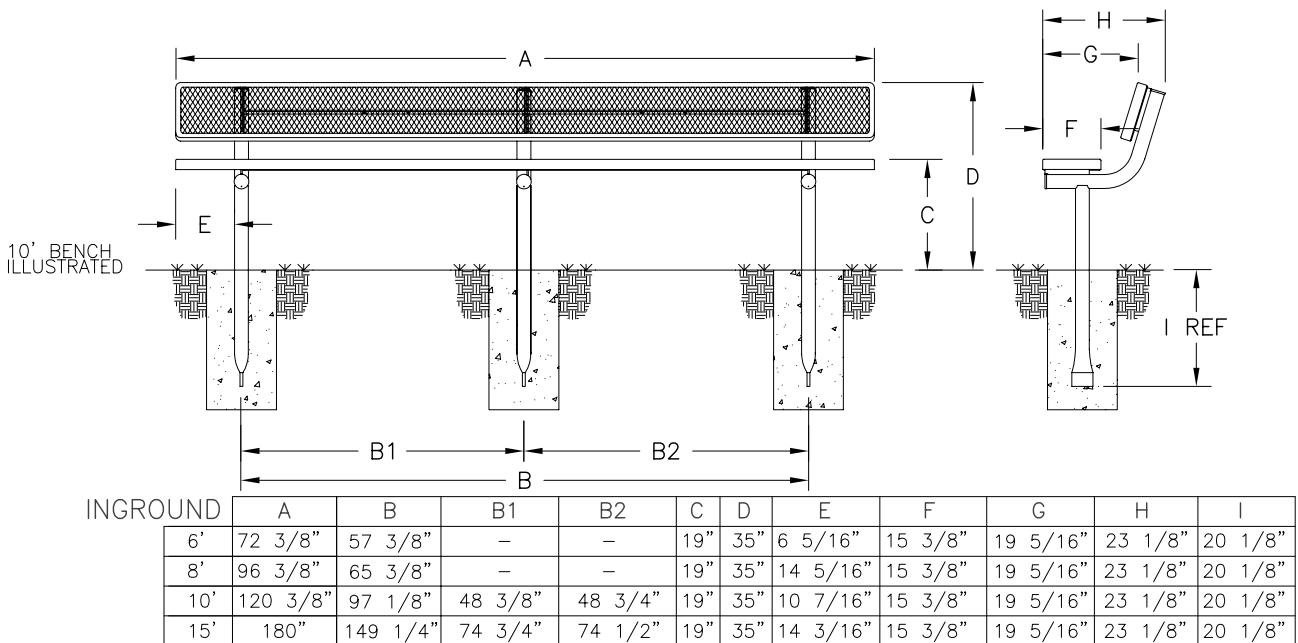
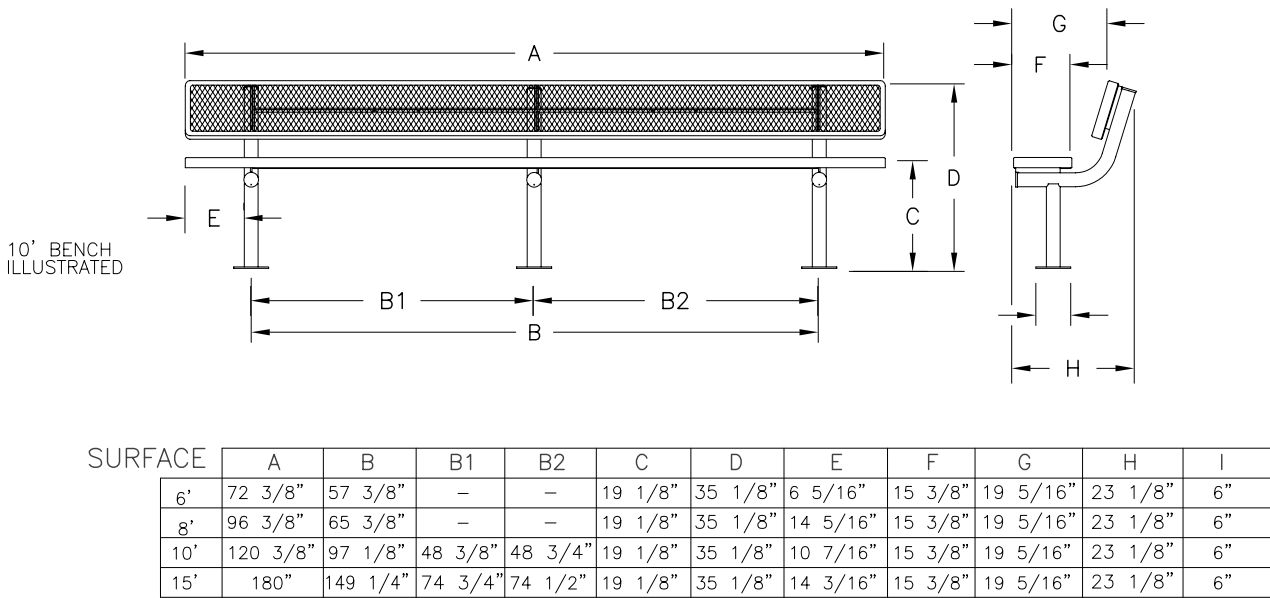
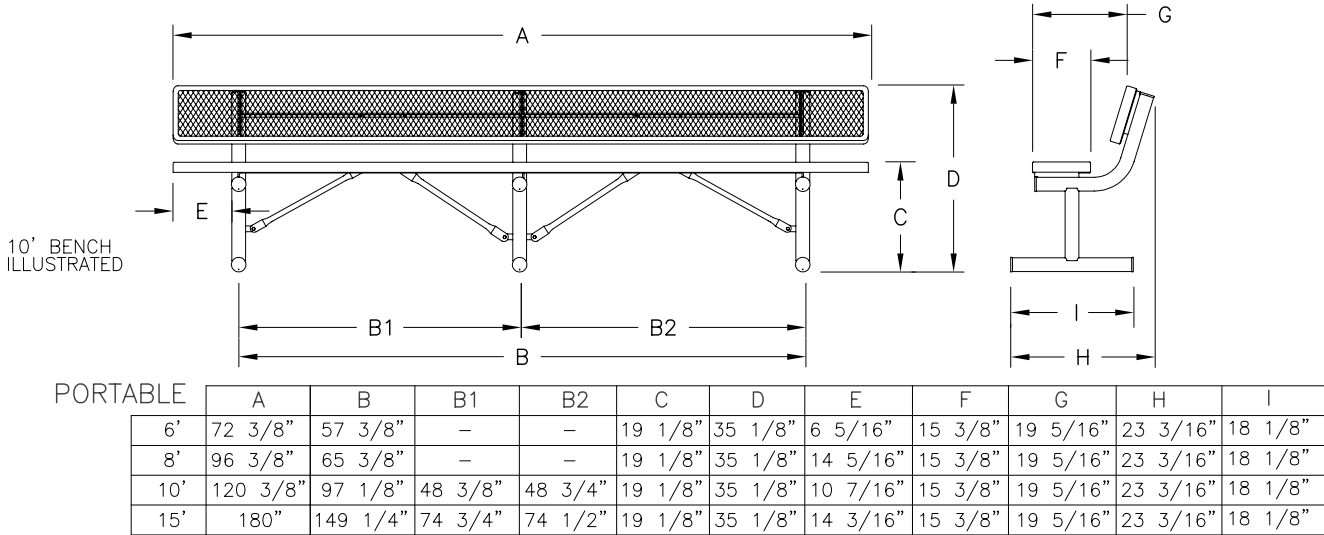

FIG. 3



installation: WARNING: The proper installation for Wabash Valley products may depend upon many factors unique to the site, location, or use of a particular product. Consult with your contractor or other professional to determine your specific installation requirements.

product dimensions:



assembly procedures, cont'd:

SURFACE

STEP 1

Invert the (A-) seat so its upside down on an elevated surface. Place edge of seat flush with surface. Attach both (B2) legs to the outer most part of the seat's mounting brackets, see FIG. 4. For 10' and 15' bench attach (B6) center leg to the right side of seat's center mounting bracket, see FIG. 5. Use two (D) and (H) using two (G) and one (J) per (D) on all legs except 15' center leg. Join the (A3) seat at squared ends with center leg and use (E) and (H) using two (G) and one (J) per (E). NOTE: Center leg has mounting brackets offset approximately 1/2".

STEP 2

Rotate bench to the upright position. Attach the second seat (A-) to the outer most part of the bench's back mounting brackets, see FIG. 6. Use two per each mounting bracket (D) and (H) using (G) and one (J) per (D). For 15' bench use two (E) and (H) using two (G) and one (J) per (E).

STEP 3

Prepare and place the foundation securement hardware in its chosen location. A detailed description of where the hole locations should be placed is shown on page 4. When the foundation securement hardware has been installed place the unit in its new location and secure to the foundation.

If mounting plate covers (C2) are used, place halves around legs and secure with 2 (I) screws, see FIG. 11. Draw to a snug fit being careful not to over tighten.

FIG. 4

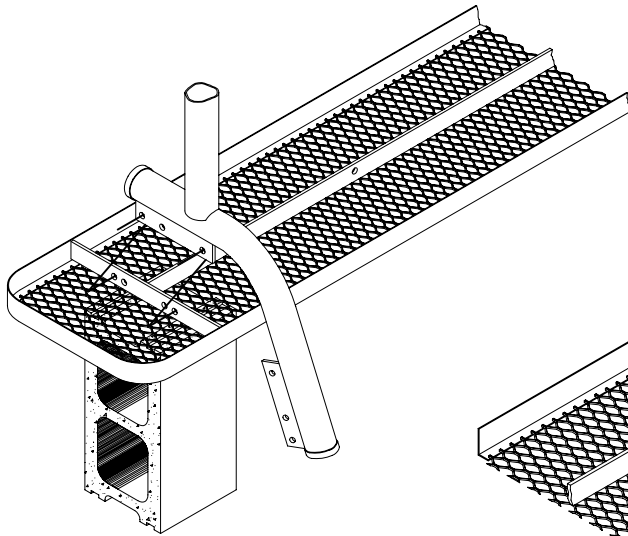

FIG. 5

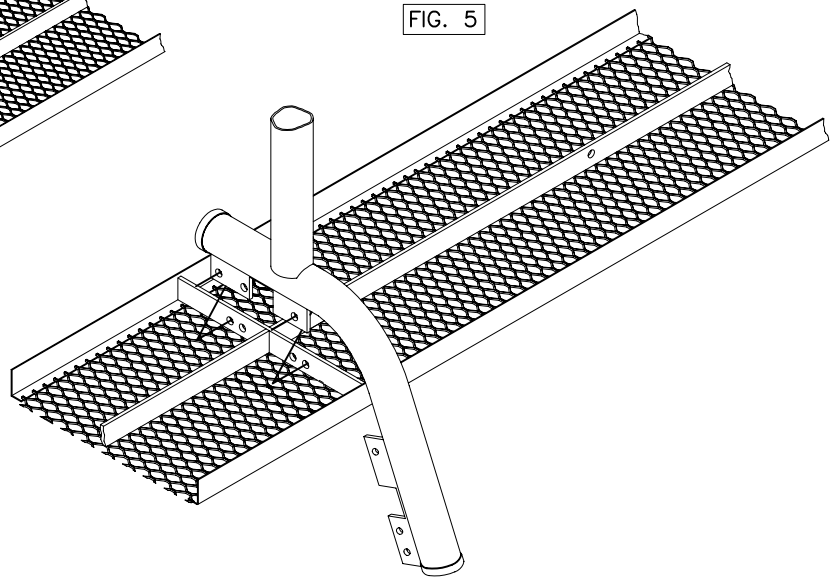

FIG. 6

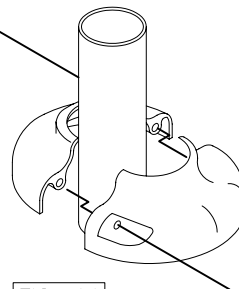
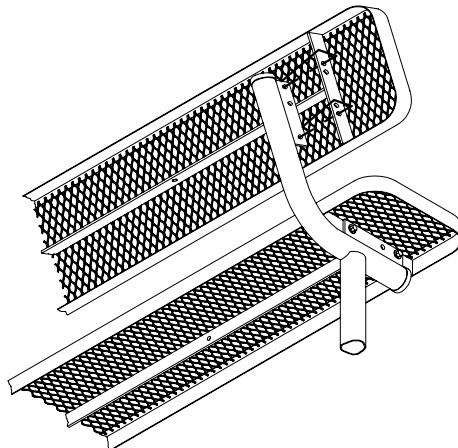

FIG. 11

assembly procedures, cont'd:

INGROUND

STEP 1

Invert the (A-) seat so its upside down on an elevated surface. Attach both (B1) legs to the outermost part of the seat's mounting brackets, see FIG. 7. For 10' and 15' bench attach (B5) center leg to the right side of the seat's center mounting bracket, see FIG. 8. Use two (D) and (H) using two (G) and one (J) per (D) on all legs except 15' center leg. Join the (A3) seat at squared ends with center leg and use two (E) and (H) using two (G) and one (J) per (E). NOTE: Center leg has mounting brackets offset approximately 1/2".

STEP 2

Prepare two foundation holes for 6' and 8' seats and three for 10' and 15' seats, see FIG. 9. The distance of the posts, center to center, are shown in a diagram on page 4. Re-invert the bench to its topside up position and place the legs in the footing holes. Block the bench as shown in FIG. 9. Before pouring concrete make sure the bench is level horizontally as well as vertically and holds 19" to the top of the bench. Pour concrete to form the footings and let cure for 48 hours.

STEP 3

Attach the second seat (A-) to the outer most part of the bench's back mounting brackets, see FIG. 10. Use two per each mounting bracket (D) and (H) using two (G) and one (J) per (D). For 15' bench use two (E) and (H) using (G) and one (J) per (E).

If mounting plate covers (C2) are used, place halves around legs and secure with 2 (I) screws, see FIG. 11. Draw to a snug fit being careful not to over tighten.

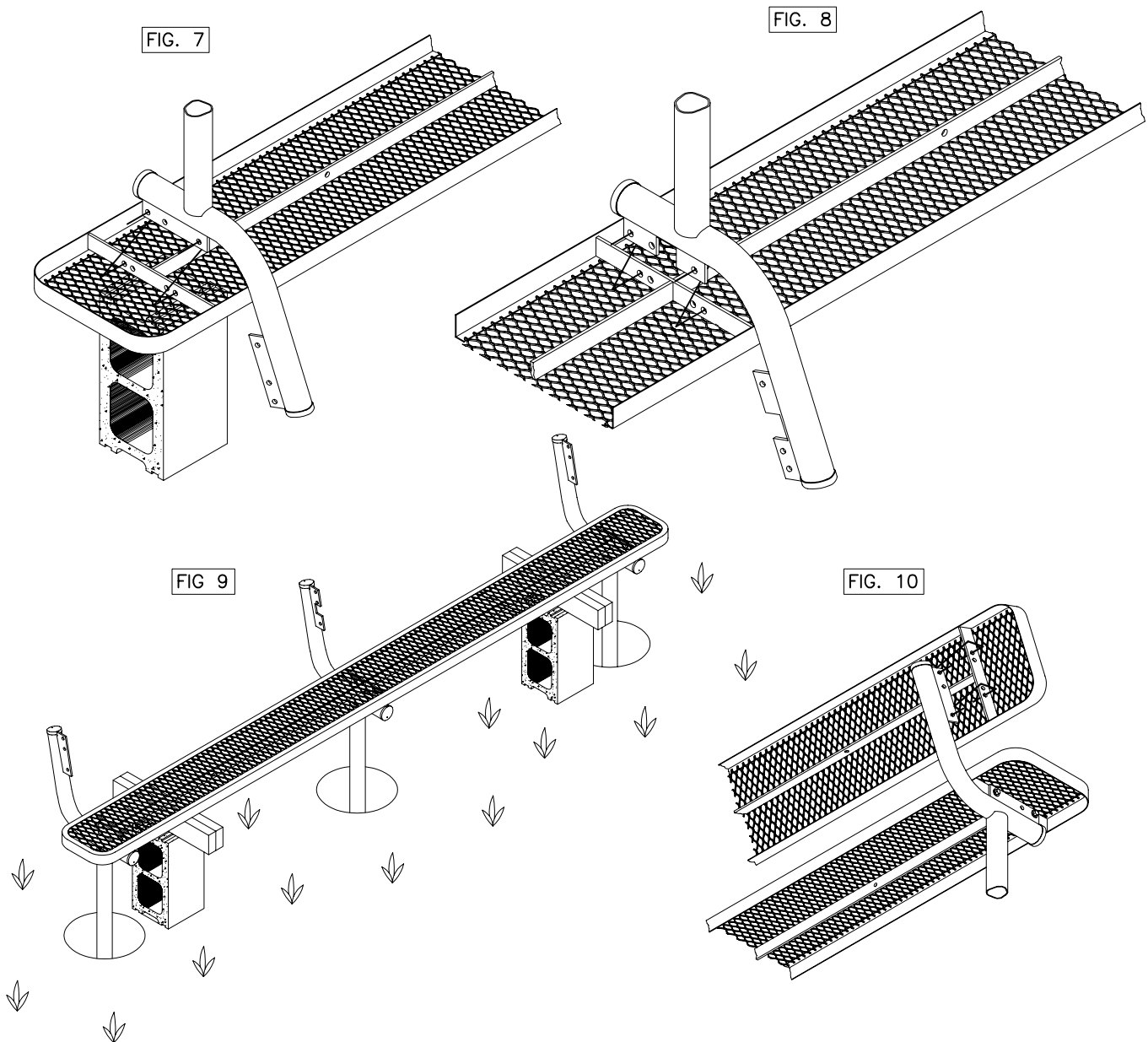

Landscape Structures Playground Equipment Quote



Box 2121
 La Grange, IL 60525
 708-579-9055
 708-579-0109 (fax)
 1-800-526-6197

August 13, 2019

WASHINGTON PARK
 ROCKFORD, IL
 OPTION 1 - REVISED
 PLAYBOOSTER/ SMARTPLAY COMPONENT SYSTEMS

<u>QTY.</u>	<u>NO.</u>	<u>DESCRIPTION</u>	<u>UNIT PRICE</u>	<u>PRICE</u>
2-5 Year Olds Play Equipment				
1	205160A	Cube DB		\$ 13,605
	includes:	Activity Table w/ Bench		
		Arch Climber		
		Arrow Panel		
		Crawl-Through panel		
		Curved Slide		
		Ladder Rail Discs		
		Magnet Stack		
		Mirror Panel		
		Nesting Puzzle		
		Puzzle Panel		
		Slotted Puzzle Panel		
		Steel Drum		
		Steering Wheel		
		Table Panel		
1	182503A	Welcome Sign (LSI Provided) Ages 2-5 years Direct Bury		-
5-12 Year Olds Play Equipment				
1	146812A	Sky Rail Climber 72"Dk DB		\$ 1,485
1	229830A	Arcade Climber DB Only		1,695
1	152907B	Deck Link w/Barriers Steel end panels 2 Steps		1,855
1	152907D	Deck Link w/Barriers Steel end panels 4 Steps		3,010
1	202594A	Portal Climber w/Permalene Handhold (Right) Equal Decks 72"Dk DB Only		5,050
1	164078A	Ring Tangle 8" Difference Deck Heights		2,085
1	176079A	Sunbeam Climber		1,615
1	152911A	Curved Transfer Module Right 32"Dk DB		2,160
1	121948A	Kick Plate 8"Rise		105
3	111228A	Square Tenderdeck	930	2,790
1	185852A	Transfer Step w/2 Handloops DB		910
3	111231A	Triangular Tenderdeck	\$ 720	2,160
1	116244A	Pipe Barrier Above Deck		565
1	120901A	Grab Bar		175
1	193174A	Sol Spinner DB		\$ 2,110

5-12 Year Olds Play Equipment Continued

1	141886A	Access/Landing Assembly Rails Barrier Left 24"Dk		\$	620
1	141887A	Access/Landing Assembly Seat Barrier Left 8"Dk			555
1	123824A	Triple Ring Fling			2,425
1	119613A	Wave Horizontal Ladder			1,215
3	111404F	108"Alum Post DB	\$	275	825
4	111404E	116"Alum Post DB		280	1,120
2	111404D	124"Alum Post DB		320	640
2	111404C	132"Alum Post DB		335	670
2	111404A	148"Alum Post DB		355	710
1	111404M	148"Steel Post DB			320
1	111404K	156"Alum Post DB			405
1	111404W	156"Steel Post DB 42" BURY			375
1	111404X	164"Steel Post DB 42" BURY			390
5	111404Z	182"Steel Post DB (44" Bury)		430	2,150
1	111404H	92"Alum Post DB			260
1	130390A	Double Swoosh Slide 96"Dk DB			2,685
1	222708A	WhooshWinder Slide 72"Dk DB			4,595
1	182503C	Welcome Sign (LSI Provided) Ages 5-12 years Direct Bury			-
		Subtotal		\$	47,730

ALSO:

1	185927A	Flywheel Spinner DB Only		\$	3,030
1	139188A	Tire Swing 5"Arch Add Bay DB Only			2,610
1	120891A	Tire Swing 5"Arch DB Only			3,545
		Subtotal		\$	9,185

Equipment Subtotal	\$	70,520
HGAC Discount - 6%		(4,231)
Shipping Costs		3,415
Equipment Total	\$	69,704

GameTime Playground Equipment Quote



GameTime c/o Cunningham Recreation
PO Box 240981
Charlotte, NC 28224
800.438.2780
704.525.7356 FAX

QUOTE
#144183

08/22/2019

Washington Park Revised

Rockford Park District
 Attn: Tom Lind
 1045 School Street
 Rockford, IL 61103
 Phone: 815-987-1649
 tomlind@rockfordparkdistrict.org

Project #: P99350
 Ship To Zip: 61103

Quantity	Part #	Description	Unit Price	Amount
1	RDU	GameTime - Modular Pro Challenge Course <i>[Accent:_____] [Basic:_____]</i> <i>[Roto Plastic:_____]</i> <i>[HDPE:_____]</i> (1) 13653 -- Ninja Steps Pro (1) 13656 -- Floating Boards (Pro) (1) 13662 -- Agility Pods (1) 13652 -- U-Turn Ramp (1) 13658 -- Sway Steps (Pro) (1) 13603 -- Traverse Wall (Pro) (2) 13655 -- Vault Wall	\$76,169.00	\$76,169.00
1	P343	GameTime - Permanent Tetherball Set <i>[Basic:_____]</i>	\$210.00	\$210.00
1	9849	GameTime - 10' Toss'N Score W/Numbers <i>[Basic:_____] [Roto Plastic:_____]</i>	\$784.00	\$784.00
2	440SS	GameTime - 4' Gooseneck w/DbI Rim- Chn Net	\$1,175.00	\$2,350.00

***Materials only quotation. This pricing does not include any offloading or installation of equipment.**

***Taxes may be applicable or tax exempt certificate will be required at time of purchase.**

Contract: USC

SubTotal: \$79,513.00
 Discount: (\$7,163.29)
 Freight: \$2,610.23
Total Amount: \$74,959.94



GameTime c/o Cunningham Recreation
PO Box 240981
Charlotte, NC 28224
800.438.2780
704.525.7356 FAX

QUOTE
#144183

08/22/2019

Washington Park Revised

GAMETIME - TERMS & CONDITIONS:

- **PRICING:** Pricing is subject to change. Request updated pricing when purchasing from quotes more than 30 days old.
- **TERMS OF SALE:** For equipment & material purchases, Net 30 days from date of invoice for governmental agencies and those with approved credit. All others, full payment for equipment, taxes and freight up front. Balance for services & materials due upon completion or as otherwise negotiated upon credit application review. Pre-payment may be required for equipment orders totaling less than \$5,000. Payment by VISA, MasterCard, or AMEX is accepted. Checks should be made payable to Playcore Wisconsin, Inc. d/b/a GameTime unless otherwise directed.
- **CREDIT APPLICATION:** Required for all non-governmental agencies and those entities who have not purchased from GameTime within the previous twelve calendar months.
- **FINANCE CHARGE:** A 1.5% monthly finance charge (or maximum permitted by law) will be added to all invoices over 30 days past due.
- **CASH WITH ORDER DISCOUNT:** Orders for GameTime equipment paid in full at time of order via check or electronic funds transfer (EFT) are eligible for a 3% cash-with-order (CWO) discount.
- **ORDERS:** All orders shall be in writing by purchase order, signed quotation or similar documentation. Purchase orders must be made out to Playcore Wisconsin, Inc. d/b/a GameTime.
- **FREIGHT CHARGES:** Shipments shall be F.O.B. destination. Freight charges prepaid and added separately.
- **SHIPMENT:** Standard Lead time is 4-6 weeks after receipt and acceptance of purchase order, credit application, color selections and approved drawings or submittals.
- **PACKAGING:** All goods shall be packaged in accordance with acceptable commercial practices and marked to preclude confusion during unloading and handling.
- **RECEIPT OF GOODS:** Customer shall coordinate, receive, unload, inspect and provide written acceptance of shipment. Any damage to packaging or equipment must be noted when signing delivery ticket. If damages are noted, receiver must submit a claim to Cunningham Recreation within 15 Days. Receiver is also responsible for taking inventory of the shipment and reporting any concealed damage or discrepancy in quantities received within 60 days of receipt.
- **RETURNS:** Returns are only available on shipments delivered within the last 60 days. A 25% (min.) restocking fee will be deducted from any credit due. Customer is responsible for all packaging & shipping charges. Credit is based on condition of items upon return. All returns must be in unused and merchantable condition. GameTime reserves the right to deduct costs associated with restoring returned goods to merchantable condition. Uprights & custom products cannot be returned.
- **TAXES:** Sales tax is shown as a separate line item when included. A copy of your tax exemption certificate must be submitted at time of order or taxes will be added to your invoice.

SUPPLY ONLY:

- All items are quoted supply only.
- Installation services are not included.
- Customer is responsible for coordinating delivery, receipt, unloading, and inventory equipment.
- Missing or damaged equipment must be reported within 60 days of delivery.

ACCEPTANCE OF QUOTATION:

Acceptance of this proposal indicates your agreement to the terms and conditions stated herein.

Accepted By (printed): _____ Title: _____

Telephone: _____ Fax: _____

P.O. Number: _____ Date: _____

Purchase Amount: **\$74,959.94**

SALES TAX EXEMPTION CERTIFICATE #: _____

(PLEASE PROVIDE A COPY OF CERTIFICATE)

Salesperson's Signature

Customer Signature



GameTime c/o Cunningham Recreation
PO Box 240981
Charlotte, NC 28224
800.438.2780
704.525.7356 FAX

QUOTE
#144183

08/22/2019

Washington Park Revised

BILLING INFORMATION:

Bill to: _____
Contact: _____
Address: _____
Address: _____
City, State: _____ Zip: _____
Tel: _____ Fax: _____
E-mail: _____

SHIPPING INFORMATION (IF DIFFERENT FROM ABOVE):

Ship to: _____
Contact: _____
Address: _____
Address: _____
City, State: _____ Zip: _____
Tel: _____ Fax: _____
E-mail: _____

Basketball Hoop

50054, 50056, 50058 - OUTDOOR BACKSTOPS

4' EXTENDED OUTDOOR BACKSTOP FOR FAN ALUMINUM BACKBOARD

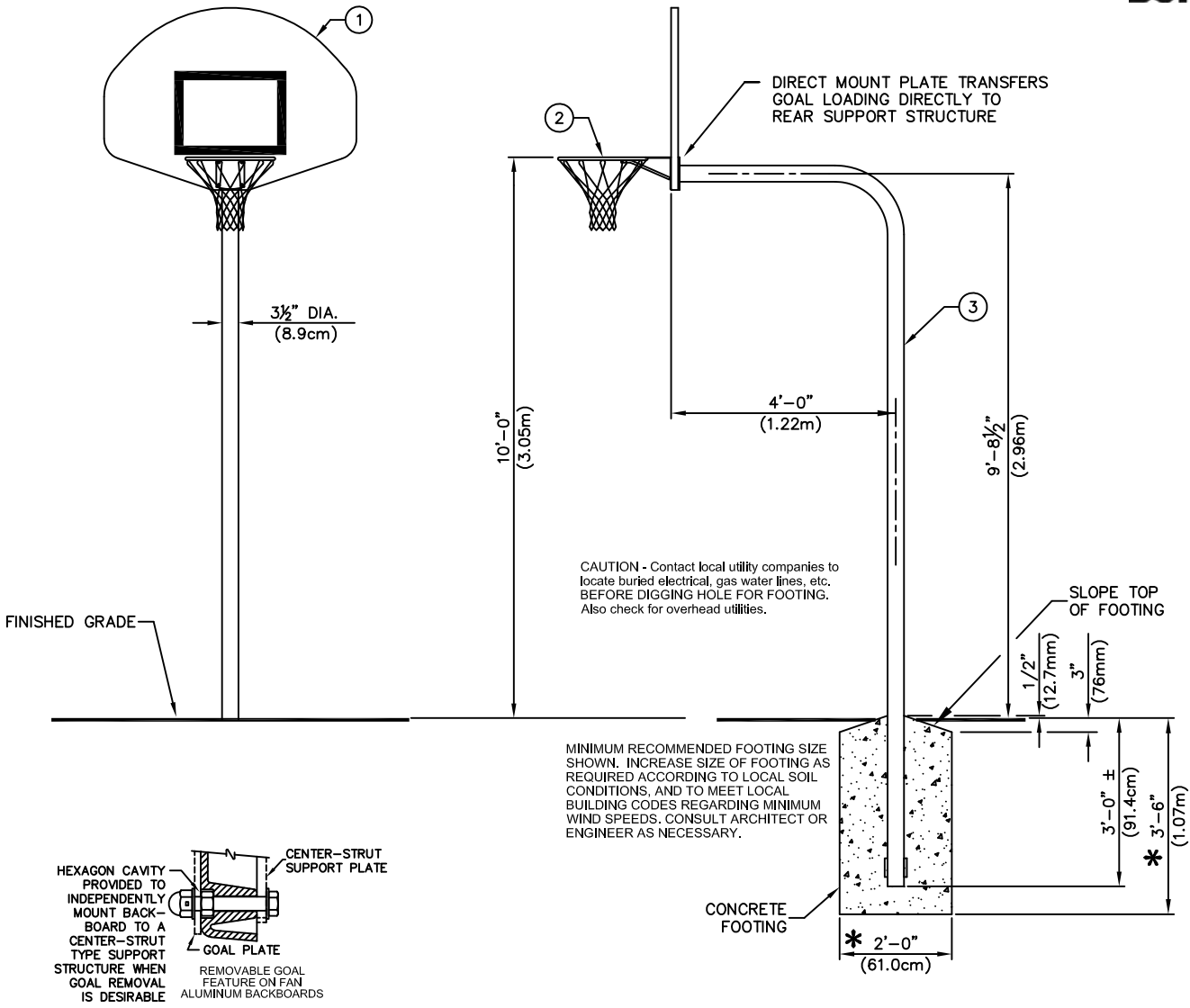

MINIMUM RECOMMENDED FOOTING SIZE SHOWN. INCREASE SIZE OF FOOTING AS REQUIRED ACCORDING TO LOCAL SOIL CONDITIONS, AND TO MEET LOCAL BUILDING CODES REGARDING MINIMUM WIND SPEEDS. CONSULT ARCHITECT OR ENGINEER AS NECESSARY.

BASKETBALL SPECIFICATION SHEET

R-50050

PARTS LIST		
No.	QTY.	DESCRIPTION
1	1	232A BACKBOARD
2	1	GOAL SEE CHART BELOW
3	1	UPRT 00161 OGO UPRIGHT: 3 1/2" DIA. ZINC FC

GOAL SELECTION		
SYSTEM	GOAL	DESCRIPTION
50054	00235000	SUPER GOAL
50056	236H00	OUTDOOR FLEX GOAL
50058	00202H00	DOUBLE RIM PLAYGROUND GOAL

50054, 50056, 50058 - OUTDOOR BACKSTOPS

4' EXTENDED OUTDOOR BACKSTOP
FOR FAN ALUMINUM BACKBOARD

SPECIFICATIONS

50054/56/58 – 4' EXTENDED SINGLE POST BACKSTOP

Upright support shall be 3-1/2" (8.89cm) O.D., 8ga. wall, zinc Flo-Coat steel tube formed to an approximate 12" (30.5cm) radius. Vertical section shall extend 3'-0" (91.4cm) into a concrete footing and shall be secured by welded anchor lugs.

Face of backboard shall be 4'-0" (1.22m) extended from the centerline of the formed upright support.

Horizontal section shall be fabricated with a special, slotted mounting plate to level the backboard and goal. Bolts from the front mounted goal shall mount directly through the backboard and into the Center-Strut® mounting plate to eliminate any strain on the backboard should a player hang on the front mounted goal.



BSN SPORTS™

BASKETBALL SPECIFICATION SHEET

R-50050

ISSUED AUGUST 09, 2017, SUBJECT TO CURRENT MANUFACTURING PROCEDURES AND CHANGES
COPYRIGHT 2017

8/09/2017

Tetherball





A PLAYCORE Company

1-800-235-2440

TETHERBALL

ISSUED/REVISED: 7/19/12

-  = INSTALLATION DETAIL
-  = PARTS LIST REFERENCE

SPECIFICATIONS

UPRIGHT POST: Shall be fabricated of 2-3/8 O.D. galvanized pipe, 10' high, 2' additional for permanent installation. A round plate will be welded on top of a cast aluminum eye. It will be used as a cap and to fasten cord.

PIPE CAP: McMaster-Carr part # 9275K32.

FINISH: All welds chipped and primed, painted aluminum over galvanizing.

344 BALL AND CORD: Shall be built for hard use with a nylon carcass and featuring a soft stingless composition cover, 26" circumference.

128 GROUND SOCKET: Shall be fabricated of 2-7/8" O.D. galvanized pipe. A round cover plate shall be welded to one end. The other end shall have a threaded coupling welded to it. Screw in brass plug furnished with socket.

HARDWARE: All nuts, bolts, screws, inserts, and lockwashers use in the assembly of all play equipment, shall be stainless steel. yellow dichromate plated steel, blue-coat plated steel, mechanically galvanized or powder coated/yellow dichromate plated steel. All primary fasteners shall be 300 series stainless steel. Fasteners with yellow dichromate treatment have an electro deposited, 99.9% pure zinc substrate applied from a specially formulated solution sealed with a yellow dichromate top coat designed to work in conjunction with the zinc plating. Yellow dichromate has a 320% longer life to white corrosion and 275% longer to red corrosion than does hot-dip galvanizing.

NOTE: All weights are based on average comparisons of each part.

SPECIFICATIONS: GAMETIME© has a policy of continuous improvement and reserves the right to discontinue or change specifications without notice.

NOTE: 342, 343, 128
P342, P343

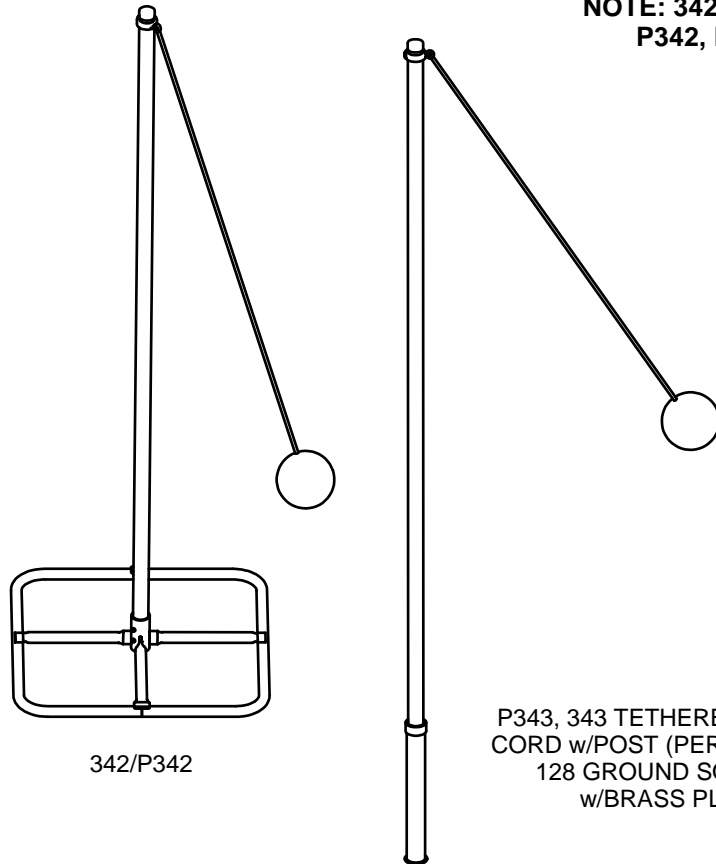

342/P342

P343, 343 TETHERBALL AND
CORD w/POST (PERMANENT)
128 GROUND SOCKET
w/BRASS PLUG

24'-0"
[7.32 M] Dia

TOP VIEW
SCALE: 1:30



**IMPORTANT PRODUCT INFORMATION
AND
SAFETY WARNINGS**



- All equipment should be installed on a soft, resilient, energy-absorbing ground surface. NEVER INSTALL PLAY EQUIPMENT ON CONCRETE OR ASPHALT. A fall on a hard surface can result in serious injury to the equipment user.
- ALWAYS FOLLOW INSTALLATION INSTRUCTIONS WHEN ERECTING EQUIPMENT.
- Worn surfaces around equipment should be restored. Concrete footings should never be exposed. Surface depth should comply with installation instructions.
- Equipment should be placed to eliminate conflicting traffic patterns.
- Test overall stability and rigidity of all play equipment. Check for proper assembly, installation and ground anchoring.
- Check for and repair damage caused by wear or vandalism, a major factor in injury-causing situations.
- GAMETIME© PROVIDES ITS CUSTOMERS WITH COMPLETE SPECIFICATION SHEETS AND INSTALLATION INSTRUCTIONS. THE SPECIFICATION SHEET CONTAINS THE LISTING OF EVERY PART USED IN A PIECE OF EQUIPMENT AND SHOULD BE KEPT IN THE CUSTOMER'S FILES FOR ACCURATE REFERENCE WHEN REPLACEMENT PARTS ARE NEEDED.
- Never add components not intended for use with this product.
- Proper maintenance of GAMETIME© equipment requires regular tightening of all bolts, nuts, and set screws.
- Never use GAMETIME© playground equipment around or in conjunction with swimming pools, ponds, lakes or any other bodies of water.

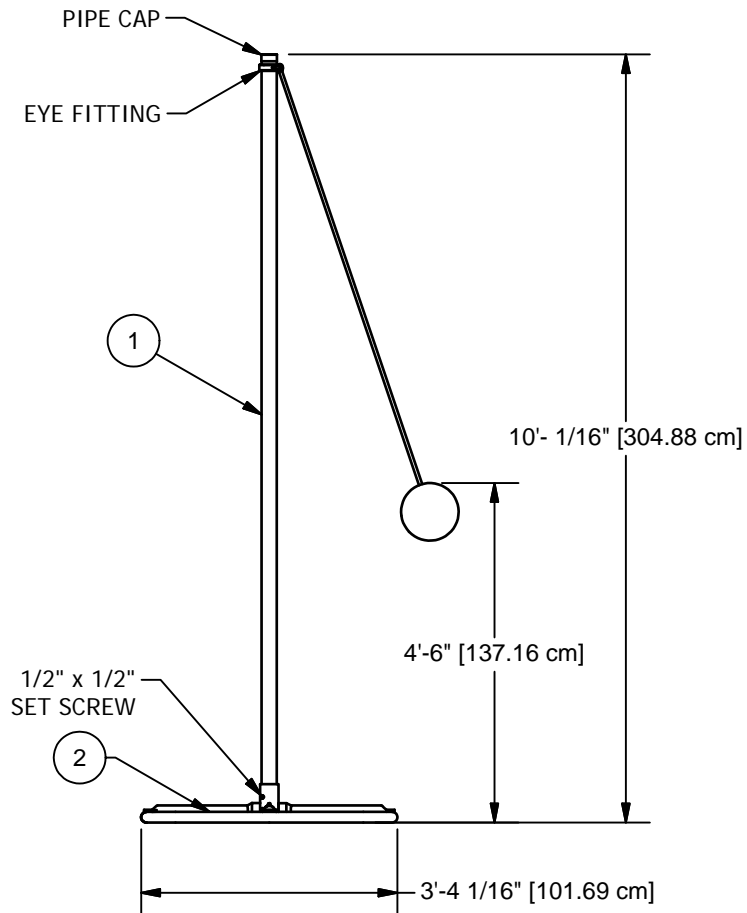

**342/P342
ASSEMBLY DRAWING**

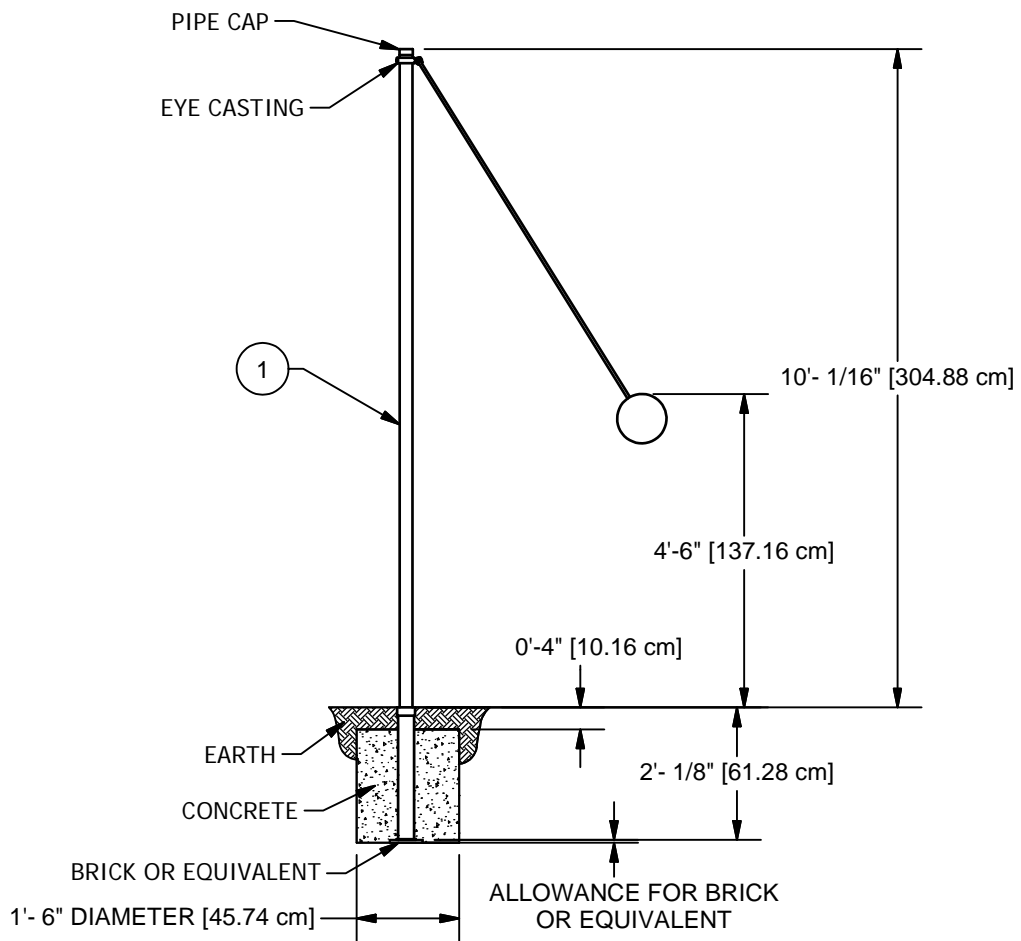

**343/P343
ASSEMBLY DRAWING**

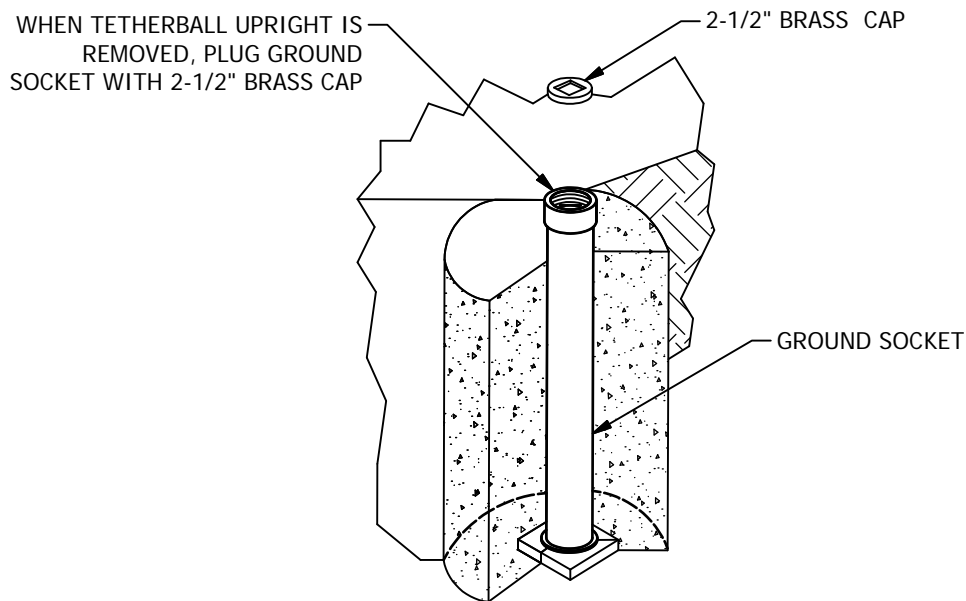

**128
ASSEMBLY DRAWING**

SET UP INSTRUCTIONS

NOTE: THIS SPECIFICATION BOOKLET SHOULD BE KEPT IN CUSTOMER'S FILE FOR FUTURE REFERENCE.

NOTE: Do not overtighten bolts. To overtighten may cause buckling or dimpling of some parts.

NOTE: Read installation instructions thoroughly before starting. Bracing material may be required during assembly.

NOTE: Do not tighten any nuts, bolts, rods, etc. until the unit is completely assembled.

PORTABLE BASE

STEP 1: Fasten ball to cord, fasten cord to aluminum eye casting. Then tighten eye casting at top of upright post with set screw. (The distance from the top of ball to ground level is 4' 6".)

STEP 2: Place upright post in socket of portable base. Tighten set screws.

STEP 3: Place cap on top of pipe.

PERMANENT

STEP 1: Place aluminum eye casting at top of upright post, tighten with set screw.

STEP 2: Place cap on top of pipe.

STEP 3: Dig required hole. Place a brick or equivalent in hole to provide a solid foundation for post.

STEP 4: Place upright post in hole, check to be sure post is level. Fill hole with concrete to be within 4" of ground level and cover concrete with dirt. Allow 48 hours minimum before using. Attach ball and cord to post.

WHEN USING GROUND SOCKET

STEP 5: Place ground socket in hole so that the top of the ground socket is level with the ground level.

STEP 6: Fill hole with concrete (leave an area accessible around set screw hole) so that you can insert a set screw. Check to be sure it is level. Allow 48 hours before using. Tighten set screw.

NOTE: Approximately .11 cubic yards [.08 cubic meters] of concrete required.

NOTE: Due to extremes in weather and soil conditions, hole sizes may have to be increased to meet local conditions.

NOTE: Loctite (supplied by others) should be used on all threaded hardware.

REPLACEMENT PARTS

REF. NO.	DESCRIPTION	128	342	P342	343	P343	PART NO.
1	UPRIGHT POST	0	1	0	0	0	100261
1	UPRIGHT POST	0	0	1	0	0	157065
1	UPRIGHT POST	0	0	0	1	0	154425
1	UPRIGHT POST	0	0	0	0	1	157064
2	PORTABLE BASE	0	1	0	0	0	100252
2	PORTABLE BASE	0	0	1	0	0	157063
	SOCKET ASS'Y	1	0	0	0	0	100468
	HARDWARE COMPLETE	0	1	1	0	0	100597
	HARDWARE COMPLETE	0	0	0	1	1	100598
	HARDWARE COMPLETE	1	0	0	0	0	100474
	1/2" X 1/2" SET SCREW	0	2	2	0	0	811559*
	2-1/2" BRASS CAP	1	0	0	0	0	101253*
	BALL & CORD	0	1	1	1	1	100599*
	EYE	0	1	1	1	1	1031*
	PIPE CAP	0	1	1	1	1	204735*

Unless Otherwise Specified, All Units of Measure are Each

** Included in Hardware*

Warning: During Installation, Hardware And Small Parts Are Choking Hazards For Young Children. Store Unused Parts Appropriately Until Assembly Is Completed. Once Assembly Is Completed, Remove Any Unused Parts From The Play Environment And Dispose/Save Them In A Secure Location.

Note: Peen Tee-Nuts and Flatwashers to match radius of pipe after assembly is complete.

Note: Loctite (supplied by others) should be used on any non-patch hardware.

Funnelball





Enriching Childhood Through Play.
1-800-235-2440

9815

TOSS 'N SCORE

ISSUED/REVISED: 12/3/14

-  = INSTALLATION DETAIL
-  = PARTS LIST REFERENCE

8' w/ CLOWN GRAPHICS	9815
8' w/ BASKETBALL GRAPHICS	9816
8' w/ NUMBER GRAPHICS	9847
10' w/ CLOWN GRAPHICS	9817
10' w/ BASKETBALL GRAPHICS	9818
10' w/ NUMBER GRAPHICS	9849

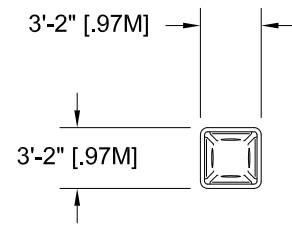
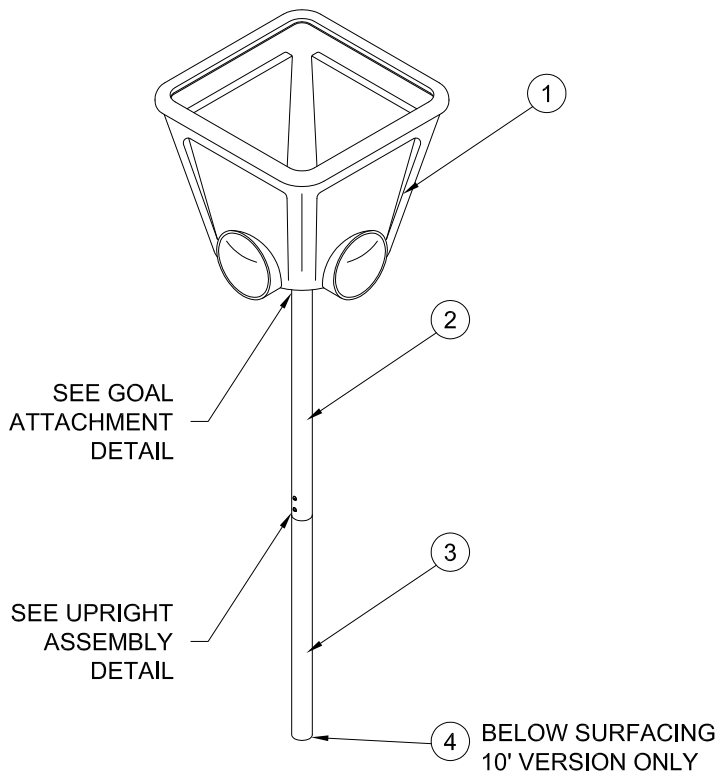

TOP VIEW

ASSEMBLY DRAWING

SPECIFICATIONS

GOAL: Shall be 1/4" rotationally molded linear low density color impregnated polyethylene.

UPRIGHT: Shall be an all welded construction of 3 1/2" O.D. galvanized pipe with 11 gauge H.R. galvanized steel spinning.

HARDWARE: All nuts, bolts, screws, inserts, and lockwashers used in the assembly of all play equipment, shall be service condition SC 2 (Moderate)

Type II zinc plated with a yellow chromate conversion coating. (ASTM B-633-85)

NOTE: All weights are based on average comparisons of each part.

SPECIFICATIONS: GAMETIME has a policy of continuous improvement and reserves the right to discontinue or change specifications without notice.



IMPORTANT PRODUCT INFORMATION AND SAFETY WARNINGS



- ALWAYS FOLLOW INSTALLATION INSTRUCTIONS WHEN ERECTING EQUIPMENT.

- Worn surfaces around equipment should be restored. Concrete footings should never be exposed. Surface depth should comply with installation instructions. Equipment should be placed to eliminate conflicting traffic patterns.

- All equipment should be free of rust and repainted whenever necessary to deter rusting.

- All protruding nuts and bolts should be covered; sharp edges on pipes should be capped or removed. Check for bent, broken or severely worn pipe and replace.

- Test overall stability and rigidity of all play equipment. Check for proper assembly, installation and ground anchoring.

- Check for and repair damage caused by wear or vandalism, a major factor in injury-causing situations.

- GAMETIME® PROVIDES ITS CUSTOMERS WITH COMPLETE SPECIFICATION SHEETS AND INSTALLATION INSTRUCTIONS. THE SPECIFICATION SHEET CONTAINS THE LISTING OF EVERY PART USED IN A PIECE OF EQUIPMENT AND SHOULD BE KEPT IN THE CUSTOMER'S FILES FOR ACCURATE REFERENCE WHEN REPLACEMENT PARTS ARE NEEDED.

- Never add components not intended for use with this product.

- Proper maintenance of GAMETIME® equipment requires regular tightening of all bolts, nuts, and set screws.

- Regular checking of all parts, castings, etc., should be made. If a part is broken or worn it should be replaced immediately.

- Never use GAMETIME® playground equipment around or in conjunction with swimming pools, ponds, lakes or any other bodies of water.

NOTE: HOLE DEPTHS INDICATED ON ALL GROUND PLANS ARE MEASURED FROM THE FINISHED SURFACE. ALL FOOTING DIMENSIONS ARE BASED ON LEVEL FINISHED SURFACE.

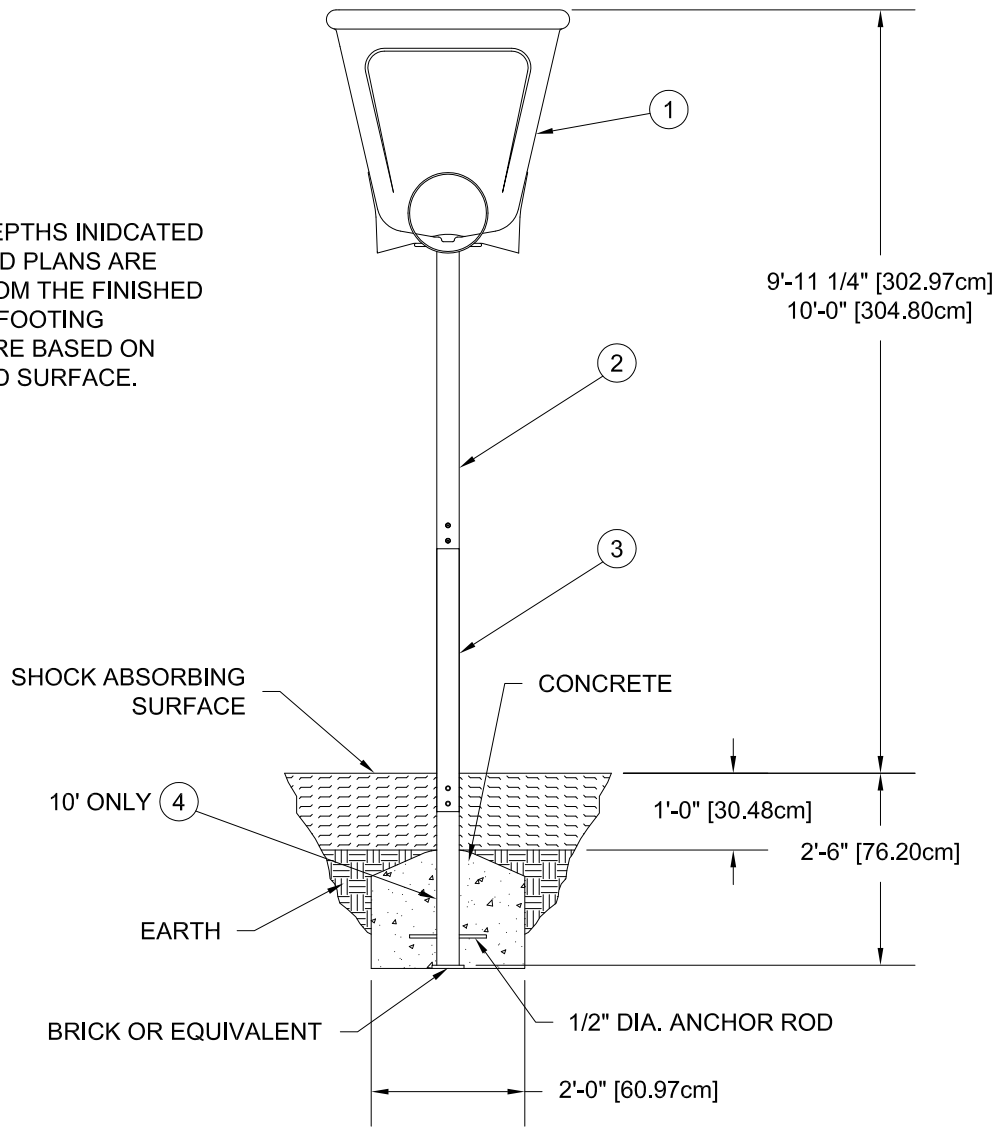

SIDE ELEVATION
10' SHOWN

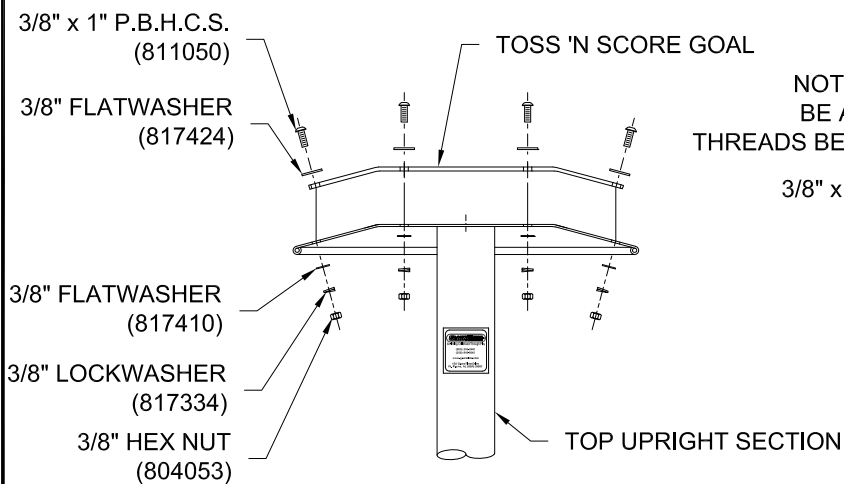

GOAL ATTACHMENT
DETAIL

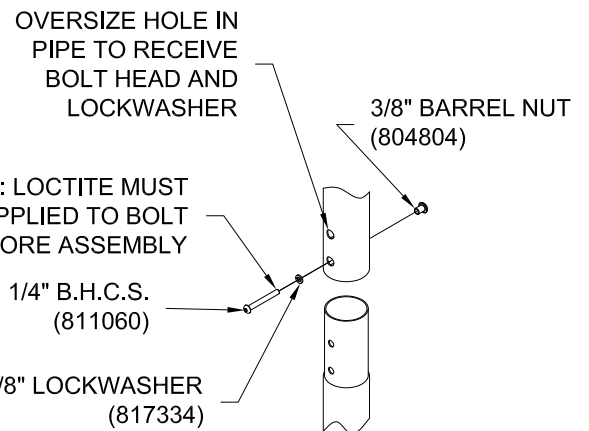

UPRIGHT ASSEMBLY
DETAIL

SET UP INSTRUCTIONS

WARNING/INSTALLATION

NOTE: THIS SPECIFICATION BOOKLET SHOULD BE KEPT IN CUSTOMER'S FILE FOR FUTURE REFERENCE.

NOTE: Do not overtighten bolts. To overtighten may cause buckling or dimpling of some parts.

NOTE: Read installation instructions thoroughly before starting assembly. Pour concrete only after final assembly is complete. Bracing material may be required during assembly.

NOTE: Do not tighten any nuts, bolts, rods, etc. until the unit is completely assembled.

NOTE: Assembly and leveling time will be greatly reduced if a transit is used to set location and depth of ground holes.

NOTE: It is important to check the hole location in the upright and on the drawings while assembling this unit.

NOTE: Place a brick or equivalent at the bottom of ground holes (where shown) to provide a solid foundation. Allow for this in hole depth.

STEP 1: Dig holes according to Assembly Drawing.

NOTE: Due to extremes in weather and soil conditions, hole sizes may have to be increased to meet local conditions.

STEP 2: Attach Upright Sections together.

See Upright Assembly Detail.

STEP 3: Attach upright pipe assembly into bottom of goal. Align holes and fasten with appropriate hardware. See Goal Attachment Detail.

NOTE: Place anchor rod in hole provided in upright as shown in Side Elevation before pouring concrete.

STEP 4: Level and plumb entire unit. Tighten all nuts, bolts, etc. Pour all ground holes with concrete to within 1'-0" [30.48cm] of finished grade. See Side Elevation drawing. Allow concrete to harden 48 hours before using. Sway bracing may be required during this step.

NOTE: Approximately 0.17 cubic yards [.13 cubic meters] of concrete required.

NOTE: Loctite should be used on all threaded hardware.

PARTS LIST

REF NO.	DESCRIPTION	No. REQ'D						PART NUMBER
		9815	9816	9817	9818	9847	9849	
1	Toss 'N Score Goal (Clown Graphics)	1	0	1	0	0	0	153199
1	Toss 'N Score Goal (Basketball Graphics)	0	1	0	1	0	0	152198
1	Toss 'N Score Goal (Number Graphics)	0	0	0	0	1	1	151992
2	Top Upright Section	1	1	1	1	1	1	209104
3	Upright Section	1	1	1	1	1	1	209106
4	Bottom Upright Section	0	0	1	1	0	1	209108
	Hardware Complete	1	1	0	0	1	0	208366
	Hardware Complete	0	0	1	1	0	1	208367
	Anchor Rod	1	1	1	1	1	1	135038*
	3/8" x 1" B.H.C.S.	8	8	8	8	8	8	811050*
	3/8" Flatwasher	8	8	8	8	8	8	817410*
	3/8" Flatwasher (1-1/4" O.D.)	8	8	8	8	8	8	817424*
	3/8" Lockwasher	10	10	12	12	10	12	817334*
	3/8" Hex Nut	8	8	8	8	8	8	804053*
	3/8" x 3 1/4" B.H.C.S.	2	2	4	4	2	4	811060*
	3/8" Barrel Nut	2	2	4	4	2	4	804804*

Unless Otherwise Specified, All Units of Measure are Each

** Included in Hardware*

Warning: During Installation, Hardware And Small Parts Are Choking Hazards For Young Children. Store Unused Parts Appropriately Until Assembly Is Completed. Once Assembly Is Completed, Remove Any Unused Parts From The Play Environment And Dispose/Save Them In A Secure Location.

BID OFFER FORM

Vendor Name

Prequalification No.

To the Rockford Park District:

The respondent declares to have carefully examined the General Conditions, Technical Specifications, Blueprints and/or Contract Drawings, Terms and Conditions, and Bid Offer Form for New Park Construction at Washington Park and hereby agrees to provide the required services in accordance with this bid and all attachments, exhibits, etc.

1. Base Bid

Complete all line item portions of the base bid form. Line items shall equal the Base Bid Amount.

- a) Site Demolition and Removals\$ _____
- b) Site Grading, Earthwork, and Drainage.....\$ _____
- c) Asphalt Paving and Striping.....\$ _____
- d) Concrete Flatwork.....\$ _____
- e) Playground Construction\$ _____
- f) Fencing\$ _____
- g) Site Furnishings and Sports Equipment.....\$ _____
- h) Site Restoration and Erosion Control\$ _____

Base Bid Total Amount:\$ _____

2. Alternate Bids

- a) Alternate Bid #1: 85LF of 4' high fencing near the sports court.....\$ _____
- b) Alternate Bid #2: 100LF of 8' high fencing near the sports court.....\$ _____
- c) Alternate Bid #3: 19 shade trees\$ _____

3. Unit Prices

Complete all portions of the unit prices form. Unit prices may be used to add to or deduct from the Contract Amount throughout the project.

- a) Perform Cuts (haul off site), per CY\$ _____
- b) Perform Cuts (remain on site), per CY\$ _____
- c) Perform Fills (import), per CY\$ _____

BID OFFER FORM

d) Asphalt Paving, per SY\$ _____
(Include 10" stone base and 3" HMA surface course)

e) PCC Sidewalk, per SF\$ _____
(Include 2" stone base, reinforcement, and 5" concrete)

f) Turf Seeding, per SY\$ _____
(Include preparation, crimped straw and seeding)

g) Silt Fence, per LF\$ _____

h) Erosion Control Blanket, per SY\$ _____
(SC150 North American Green)

i) Concrete Sidewalk, per SF\$ _____
(Include 2" stone base, reinforcement, and 5" concrete)

j) Install Engineered Wood Fiber, per CY\$ _____
(Material provided by Owner)

4. Can meet completion date of May 22, 2020? Yes _____ No _____

5. Statement of warranty / guarantee (*Specify length of warranty and provide description of what is covered, i.e. Parts and labor*):

6. Addendum(s) Receipt: Acknowledge the receipt of Addendum ____ to ____ inclusive.

REFERENCES:

Contractor to provide three references of similar type work that would qualify your firm for this project.

	Company Name / Address	Contact Person and Phone No.
1.	_____	_____
2.	_____	_____
3.	_____	_____

The State of Illinois Human Rights number or Public Contracts number under the Fair Employment Practices Law is: _____ (We do not have a State of Illinois Human Rights number or Public Contracts number. In lieu thereof, we will make application at (312) 814-2432 for it within 30 days from the date of this bid opening.)

Check box if you are making application.

BID OFFER FORM

Contractor Safety Qualification Questionnaire

Date of Submittal: _____

Specify Type of Contractor: Check all that apply.

- ____ Construction Manager
- ____ General Contractor
- ____ Self-Performing General Contractor
- ____ Specialty Contractor: Check all that apply.
 - a. ____ Electrical
 - b. ____ Hazardous Abatement
 - c. ____ HVAC
 - d. ____ Roofing
 - e. ____ Other, Specify: _____

Company Name: _____

Address: _____

City/State: _____ Zip Code: _____

Business Phone: (____) _____ Fax: (____) _____

As the authorized representative of the company, I certify that the information provided on this contractor safety qualification questionnaire is true and correct. I understand that willful falsification of information may result in debarment or suspension as provided under applicable law.

Authorized Representative: _____
(Print Last, First and MI)

Title: _____

Signature: _____ Date: _____

Name of Representative Completing Form: _____

Title: _____ Business Phone: (____) _____

Previous Calendar Year Work Hours: _____

Provide the following information using the last three (3) years OSHA 300 forms

During the previous three (3) calendar years to the present time, has your company incurred a work related fatality to your work force? No ____ Yes ____

If yes, describe incident(s), date(s) and location of work related fatality(s) on a separate piece of paper and attach to this document.

BID OFFER FORM

Total OSHA Recordable Incident Rate: _____

Total OSHA Severity Rate: _____

Identify your company's Experience Modification Rate (EMR) for the last three (3) years.

Year _____	EMR _____
Year _____	EMR _____
Year _____	EMR _____

Has your company received any regulatory government agency (i.e. OSHA, MPCA, EPA, DOT) citations during the previous two (2) calendar years to the present time?No ____ Yes ____

If yes, please explain: _____

BID OFFER FORM

Prequalified Contractors do not need to complete this page.

If not prequalified, the following documents are required are to be included with this Bid Offer Form. Please indicate that they are attached:

1. Contractor has submitted the documents for prequalification?.....Yes _____ No _____
(Prequalification is an annual process. If your firm has not submitted for 2018 please answer "no".)
2. Completed Safety and Health Questionnaire is attached? *(To be completed and included with each bid)*.....Yes _____ No _____
3. Certificate from US DOL indicating participation in apprenticeship programs Attached _____ On file _____
4. Copy of trade or professional license if required..... Attached _____ N/A _____

Please complete the checklist below and include any required attachments. Failure to respond to any item may result in a delay in awarding of the contract or may result in being disqualified.

Contractor shall comply with the responsible bidder ordinance for any public works project over \$10,000. Does the contractor :	YES	NO
Follow Equal Opportunity Employer provisions for workforce?		
Have any tax liens or tax delinquencies in last 5 years?		
Remain compliant with all provisions of the IL Substance Abuse Prevention on Public Works Act?		
Require sub-contractors to be in compliance as well with the responsible bidder ordinance?		
Have any history of suspension or revocation of professional or trade license? Provide copy of current license if state law or local ordinance requires licensure?		
Have a current Certificate of Insurance on file that is valid for the time frame of the project with the Park District? <i>(To be supplied to RPD upon award.)</i>		
Participate in contractor's safety and health activities and programs?		
Respondent participates in contractor's safety and health activities and programs which includes a written safety policy and a written safety manual in place and will be able to furnish both upon request.		
Federal Employer Tax Identification Number or Social Security Number <i>(for individuals)</i>		
Registration with IL Department of Revenue UI account number		
Contractor shall indicate whether individuals on the project are classified as either (i) an employee or (ii) an independent contractor under all applicable state and federal laws and local ordinances.		

BID OFFER FORM

Certified Payroll Records

The Rockford Park District requires the payment of prevailing wages. All invoices for Prevailing Wage work must be submitted with **CERTIFIED PAYROLL RECORDS**. The Park District **will not pay** any invoice for prevailing wage work that does not have appropriate certified payroll records attached. The contractor and all subcontractors shall pay Prevailing Wage rates to employees as required and stipulated by Federal, State and Local laws.

The undersigned has checked the plan(s), specifications, and the above figures and accepts responsibility for any errors or omissions in effecting coverage based on these specifications as submitted on the Bid Offer Form.

It is understood and agreed that the Rockford Park District reserves the right to accept or reject any or all bids and to waive informality in any bid received.

By signing this form, the contractor certifies that all statements made are valid and true to be best of the contractor's knowledge.

The undersigned declares that this bid is made without any connection with any person making another bid for the same contract, that the bid is in all respects fair and without collusion or fraud, that no member of the Board of Rockford Park District or other officer of said Park District, or any person in the employ of said Park District is directly or indirectly interested in this bid, or in any portion of the profits thereof. The undersigned certifies that all statements made are valid and true to be best of their knowledge.

Name of Company or Firm Providing Bid

Address

City

State

Zip+4

(Name Typed)

Title

Phone Number

Fax Number

Cell Phone Number

E-mail Address

Bid Offer Form is not valid unless signed by company officer:

Signature of Company Officer (Signature Required)

Date

SUBCONTRACTORS LIST

The bidder shall enter the names and the type of work to be done in the Subcontractors List which follows for each Subcontractor that the Bidder proposes to use for the work who will be providing work for an agreed price of five percent (5%) or greater of the amount Bid.

Only one (1) Subcontractor shall be listed for each work item. Upon award of a Contract, the named Subcontractors shall be employed to perform the work, unless the Owner specifically authorizes changes. Failure to furnish all information requested may render the Bid non-responsive if it is determined that such omission is material by affording the Bidder a substantial advantage over other Bidders.

Except as otherwise specifically stated by the Bidder in this Section, omission of any names of Subcontractors herein shall constitute an affirmative representation and statement that the Bidder proposes to use the company's own work forces for most of the work such that will no Subcontractors will provide work in the amount of five percent (5%) or greater of the amount Bid.

Subcontractor Name	Work	Price
		\$
		\$
		\$
		\$
		\$
		\$
		\$
		\$
		\$
		\$

By: _____

ROCKFORD PARK DISTRICT

MINORITY, WOMEN and DISABLED-OWNED BUSINESS CONCERN REPRESENTATION

Minority-Owned Business: a minority-owned business concern means a business concern that: (1) is at least 51 percent unconditionally owned by one or more individuals who are considered to be a member of a minority group, or a publicly owned business having at least 51 percent of its stock unconditionally owned by one or more members of a minority group; and (2) has its management and daily business controlled and operated by one or more such individuals. Individuals who certify that they are members of minority groups (African Americans, Hispanic Americans, Native Americans, Asian-Pacific Americans, Asian-Indian Americans, and other minorities) are to be considered minority-owned enterprises.

Women-Owned Business: a business that is at least 51 percent owned by a woman or women who also control and operate it.

Disabled Owned Business: a business that is at least 51 percent owned by a person or persons with severe physical or mental disabilities, which substantially limits one or more of the person's major life activities and which person or persons control, and operate such business.

"Control" in this referenced context means exercising the power to make policy decisions. "Operate" means being actively involved in the day- today management of the business.

The Rockford Park District shall rely on written representations of concerns regarding their status as minority/women/disabled-owned businesses. Offeror agrees to submit information regarding the minority ownership of its subcontractors on request of the District.

COMPLETE THE SECTION BELOW AND RETURN THIS FORM WITH BID. FAILURE TO DO SO MAY RENDER THE OFFEROR'S BID UNACCEPTABLE.

- A. Representation. The Offeror represents that it is (), is not () a minority-owned business concern.
- B. Representation. The Offeror represents that it is (), is not () a women-owned business concern.
- C. Representation. The Offeror represents that it is (), is not () a disabled-owned business concern.

Please Check Appropriate Box/Boxes

- African American (AFRAM) Caucasian (CAUC) Native American (NAAM)
- Hispanic American (HISP) Asian-Pacific American (ASIAP) Asian Indian (ASIAI) American
- other, please identify: Woman Owned (W) Disabled Owned (D)

The Offeror has has not used the following procedures in searching for and obtaining suppliers and subcontractors:

- Place Minority-Owned Businesses on solicitation lists.
- Ensure that Minority-Owned are solicited whenever they are potential sources.
- Consider contracting with consortia of Minority-Owned Businesses when an intended contract is too large for any one such firm to handle on its own or, if economically feasible, divide larger requirements into smaller transactions for which such organizations might compete.
- Make information on contracting opportunities available and establish delivery schedules that encourage participation by Minority Owned Businesses.
- Use the services and assistance of the SBA and Department of Commerce Minority Business Development Agency, as appropriate.

Company Name	Address	
<hr/>		
City	State	Zip
<hr/>		
Phone #	Email Address	FEIN #
<hr/>		
Signature of Company Official		Title
		<hr/>

Date

Label for Sealed Bid Envelope

Cut out and tape label below to the lower left hand corner of your return sealed Bid envelope.

Return To:
401 South Main Street
Rockford, IL 61101

<p>Bid No. 12-2233</p> <p>Do Not Open Until Thursday 9/19/19 @ 2:30 p.m.</p> <p>Submitted By: _____ Vendor Name</p>
--