



LUMPKIN COUNTY BOARD OF COMMISSIONERS

INVITATION TO BID

ASPHALT LEVELING AND RESURFACING OF VARIOUS COUNTY ROADS

LMIG PROJECT #2018-001

SUBMISSIONS ARE DUE AT THE ADDRESS SHOWN BELOW NO LATER THAN

Thursday, March 1, 2018 @ 2:00 P.M., EST

ELECTRONIC SUBMISSIONS VIA E-MAIL OR FAX WILL NOT BE ACCEPTED.

**LUMPKIN COUNTY BOARD OF COMMISSIONERS
ATTENTION: RYAN MCDUFFIE, PURCHASING AGENT
99 COURT HOUSE HILL, SUITE D
DAHLONEGA, GA 30533**

**THE RESPONSIBILITY FOR SUBMITTING A RESPONSE TO THIS ITB ON OR BEFORE THE STATED
DATE AND TIME WILL BE SOLELY AND STRICTLY THE RESPONSIBILITY OF THE OFFEROR.**

ISSUE DATE: JANUARY 31, 2018

INVITATION TO BID

LUMPKIN COUNTY BOARD OF COMMISSIONERS IS REQUESTING SEALED BIDS FOR ASPHALT LEVELING, AND RESURFACING OF VARIOUS COUNTY ROADS.

A BID BOND IN THE AMOUNT NOT LESS THAN 5% OF THE TOTAL BID AMOUNT IS REQUIRED OF THIS PROJECT. BIDS WILL BE RECEIVED BY LUMPKIN COUNTY BOARD OF COMMISSIONERS, PURCHASING DEPARTMENT, 99 COURTHOUSE HILL, SUITE D, DAHLONEGA, GEORGIA 30533 UNTIL 2:00 PM, EST ON THURSDAY, MARCH 1, 2018. LATE BIDS WILL NOT BE CONSIDERED NOR RETURNED. BIDS WILL BE FORMALLY ACCEPTED AND ACKNOWLEDGED AT THE COUNTY ADMINISTRATION BUILDING BY STAFF PERSONNEL.

THE BID DOCUMENTS AND SPECIFICATIONS ARE AVAILABLE FOR INSPECTION AT THE LUMPKIN COUNTY PURCHASING DEPARTMENT, 99 COURTHOUSE HILL, SUITE D, DAHLONEGA, GEORGIA AND AT WWW.LUMPKINCOUNTY.GOV.

BIDS MAY NOT BE WITHDRAWN FOR NINETY (90) DAYS AFTER THE TIME AND DATE SET FOR CLOSING, EXCEPT AS ALLOWED BY OCGA. LUMPKIN COUNTY RESERVES THE RIGHT TO REJECT ANY AND ALL BIDS AND TO WAIVE ANY TECHNICALITIES.

1.0 **INTRODUCTION**

1.1 **Purpose of Procurement**

The Lumpkin County Board of Commissioners is requesting sealed bids for the asphalt leveling and resurfacing of various county roads.

1.2 **Schedule of Events**

This Invitation to Bid shall be governed by the following schedule:

DATE	ACTIVITY
Wednesday, January 31, 2018	Release of Invitation to Bid
Friday, February 16, 2018 2:00 PM	Mandatory Pre-Bid Meeting held at Lumpkin County Administration Building Conference Room, 99 Courthouse Hill, Dahlonega, GA 30533
Wednesday, February 21, 2018 12:00 PM	Deadline for written questions to be submitted to Purchasing Agent
Friday, February 23, 2018 5:00 PM	Answers to written questions posted to website: www.lumpkincounty.gov
Thursday, March 1, 2018 2:00 PM	Bids Due and Bid Opening. Bids will be accepted until time of opening. No bids will be accepted after the due date and time.

1.3 **Restrictions on Communications**

From the issue date of this Invitation to Bid until a contractor is selected and the award is announced, Contractors are not allowed to communicate **for any reason** with any County staff or elected officials except: 1) through the Purchasing Agent named herein, 2) at the Pre-Bid Meeting, if applicable or 3) as provided by existing work agreement(s). The County reserves the right to reject the submittal of any bidder violating this provision.

1.4 **Pre-Bid Meeting**

A Mandatory Pre-Bid meeting will be held Friday, February 16, 2018 at 2:00pm. The location of the meeting will be the Lumpkin County Administration Building Downstairs Conference Room, 99 Courthouse Hill, Dahlonega, GA 30533.

1.5 **Questions & Addenda**

All questions concerning this **bid must be submitted in writing** (email is preferred but fax and mail may be used) to the Purchasing Agent on February 21, 2018, no later than 12:00 PM, EST.

The Inquiries must be directed to:

Ryan McDuffie, Purchasing Agent
Lumpkin County Board of Commissioners
99 Courthouse Hill, Suite D
Dahlonega, GA 30533
ryan.mcduffie@lumpkincounty.gov
Fax (706) 482-2201

No response to inquiries other than written will be binding upon the County. Lumpkin County reserves the right to issue written addenda to any inquiries that alter the scope of the Invitation to Bid. Addenda shall be posted to the county website, www.lumpkincounty.gov on February 23, 2018, no later than 5:00 PM. A signed copy of any addenda shall accompany submitted bids. Bidders are advised to check the website for addenda before submitting their bids.

1.6 Contract Term

The contract between the County and the Contractor shall become effective upon signing and shall be completed no later than 180 calendar days from the day the Notice to Proceed is issued. Lumpkin County reserves the right to terminate contract at any time if successful bidder fails to meet requirements stated in this bid.

The contract shall terminate absolutely and without further obligation at such time as appropriated and otherwise unobligated funds are no longer available to satisfy the obligations of the County under this contract.

1.7 Bonds

Bid Bonds	5% of total bid amount
Performance and Payment Bonds	100% of total contract price (required of awarded vendor only)

Information regarding bonds to be furnished is stated in the General Terms section of this Bid document, Item 3.8 “Bid/Proposal Bonds, Payment Bonds and Performance Bonds”.

1.8 Submission of Bids

One (1) original and two (2) copies of the complete signed submittal must be received **March 1, 2018 AT 2:00 PM, EST**. Proposals must be submitted in a sealed envelope stating on the outside, the vendor’s name, address and “**Asphalt Leveling and Resurfacing – Project # 2018-001-ITB**” to:

**Ryan McDuffie, Purchasing Agent
Lumpkin County Board of Commissioners
99 Courthouse Hill, Suite D
Dahlonega GA 30533**

Bid responses submitted by fax or electronic mail (email) will **NOT** be accepted.

Bidders are advised to allow adequate time for shipping. **Many express mail and delivery services do not guarantee overnight delivery by noon to Lumpkin County.** Any bid received after 2:00 pm on March 1, 2018, will not be opened.

1.9 Withdrawal of Bid Due to Errors

Bidders shall have up to forty-eight (48) hours to notify the Lumpkin County Purchasing Department, in writing, of an obvious clerical error made in the calculation of bid in order to withdraw a bid after bid opening. Bids may be withdrawn from consideration if the price was substantially lower than the other bids due solely to a mistake. The bidder shall provide evidence that the bid was submitted in good faith, and that the mistake was a clerical mistake as opposed to a judgment mistake. The bidder’s original work papers shall be the sole acceptable evidence of error or mistake. If a bid is withdrawn under this provision, the lowest remaining responsive bid shall be deemed low bid.

No bidder who is permitted to withdraw a bid shall for compensation, supply any material or labor, perform any subcontract or other work agreement for the person, or firm to whom the contract is awarded.

Bid withdrawal is not automatically granted and will be allowed solely at Lumpkin County’s discretion.

1.10 Award

Any purchase order / contract awarded pursuant to this Invitation to Bid shall be awarded to the lowest responsive and responsible bidder whose bid response meets the requirements and specifications set forth in this Invitation to

Bid. A “responsive bidder” is a bidder who has submitted a bid response, which conforms in all material respects to the bid. A “responsible bidder” is a bidder who has the capacity in all respects to perform fully the contract requirements and the integrity and reliability which will assure good faith performance.

2.0 SCOPE OF WORK & SPECIFICATIONS

The scope and procedure for this project shall consist of Leveling, and Topping with asphalt concrete on various county roads listed in the LMIG Project Report contained in the Bid Documents for this project. All work shall be done in accordance with the 2013 State of Georgia Standard Specifications and by the Special Provision contained in the Bid Documents for this project.

Lumpkin County personnel will be supervising construction of this project and will also be subject to inspections and audits by the Georgia Department of Transportation.

2018 LMIG BID ITEM SUMMARY						
ROAD NAME	BEGIN	END	LENGTH (Miles)	WIDTH (FEET)	DESCRIPTION OF WORK	
					ASPHALT REQUIREMENTS	STRIPING REQUIREMENTS
Old Dahlonega Hwy	SR 52	Hall County line	4.5	25	Spot level and Overlay with 175 #/sqyd of 12.5 mm	Centerline, Edge line, and stop bars.
Seabolt Stancil	Porter Springs Rd	End of Pavement	0.75	17	Spot level and Overlay with 175 #/sqyd of 12.5 mm	Stop bars.
Lakeview Drive	Lumpkin County Pkwy	Cul de sac	0.60	20	Spot level and Overlay with 175 #/sq.yd. of 12.5 mm	Centerline and stop bars.
			Total Mileage 5.85 miles			Stop bars to be included in striping price

3.0 TERMS AND CONDITIONS

3.1 Bid Amendments

The County reserves the right to amend this Bid prior to the bid due date. All addenda and additional information will be posted to the County website no later than 5:00 PM on February 23, 2018. It is the Bidder's responsibility to check the website for addenda before submitting a Bid. A signed copy of all issued addenda is to be included with the Original Bid.

3.2 Bid Withdrawal

A submitted bid may be withdrawn prior to the due date by a signed written request to the Purchasing Agent.

3.3 Cost for Preparing Bids

The cost for developing the bid is the sole responsibility of the Bidder. The County will not provide reimbursement for such costs.

3.4 Conflict of Interest

If a Bidder has any existing client relationship that involves Lumpkin County, the Bidder must disclose each relationship.

3.5 Contractor Selection

Lumpkin County reserves the exclusive right to determine which Bidder should be awarded the Contract. The County also reserves the right to reject any or all bids at its discretion with or without cause.

3.6 Negotiations with Apparent Winner

Prior to award, the apparent winning Bidder will be required to enter into discussions with the County to resolve any contractual differences. These discussions are to be finalized within one (1) week of notification unless extending the time period is advantageous to the County. Failure to resolve differences will lead to rejection of the Contractor's bid.

The County reserves the right to negotiate modifications and costs with the successful Bidder provided that no such modifications affect the evaluation criteria set forth herein.

The Contractor shall commence work only after the transmittal of a fully executed contract and Notice to Proceed from the County.

3.7 Taxes

Lumpkin County is exempt from taxes; however, the Contractor shall pay all taxes required of him by law. Lumpkin County cannot exempt others from tax.

3.8 Bid/Proposal Bonds, Payment Bonds, Performance Bonds (if required)

A five percent (5%) Bid Bond and a one hundred percent (100%) Performance and Payment Bond shall be furnished to Lumpkin County if stated as required in Paragraph 1.7 in the "Introduction" section of this document. Failure to submit appropriate bonding will result in automatic rejection of bid. Bonding company must be authorized to do business in Georgia by the Georgia Insurance Commission, listed in the Department of Treasury's publication of companies holding certificates of authority as acceptable surety on Federal bonds and as acceptable reinsuring companies, and have an A.M. Best rating.

3.9 Compliance with Laws

The Contractor will comply with all State and Federal laws, rules, and regulations.

3.10 Cancellation for Cause

Lumpkin County reserves the right to terminate the contract immediately in the event that the Contractor discontinues or abandons operations; is adjudged bankrupt, or is reorganized under any bankruptcy law; or fails to keep in force any required insurance policies or bonds.

Failure of the successful contractor to comply with any section or part of the contract will be considered grounds for immediate termination of the contract by the County without penalty to Lumpkin County. Lumpkin County shall pay for services rendered up to the point of termination.

Notwithstanding anything to the contrary contained in the contract between the County and the successful contractor, the County may, without prejudice to any other rights it may have, terminate the contract for convenience and without cause, by giving thirty (30) days written notice to the successful contractor.

If the termination clause is used by the County, the successful contractor will be paid by the County for all scheduled work completed satisfactorily by the successful contractor up to the termination date set forth in the written termination notice.

3.11 Condition of Materials

It is understood and agreed that materials delivered shall be new, of latest design, and in first quality condition and must meet all Georgia Department of Transportation specifications.

3.12 Rejection of Submissions/Cancellation of Bids

Lumpkin County reserves the right to reject any or all bids, to waive any irregularity or informality in a bid, and to accept or reject any item or combination of items, when to do so would be to the advantage of Lumpkin County. It is also within the rights of Lumpkin County to reject bids that do not contain all elements and information requested in this document. Lumpkin County reserves the right to cancel this Invitation to Bid at any time. Lumpkin County will not be liable for any cost/losses incurred by the Contractors throughout this process.

3.13 Non-discrimination

Lumpkin County does not discriminate on the basis of race, religion, color, sex, national origin, age, or disability.

3.14 Payment

Contractor shall itemize all invoices in full. The original of the invoice shall be mailed to:

**Lumpkin County Board of Commissioners
Attn: Accounts Payable
99 Courthouse Hill, Suite D
Dahlonega, GA 30533**

Each invoice must include the following information:

1. Date of Invoice
2. Service Performed
3. Billing Period
4. Terms
5. All billable items must be itemized
6. Appropriate Unit of Measure

Contractor must furnish documentation identifying that this work has been completed in accordance with specifications, quantities, and price as set forth in the contract.

Approved invoices (less retainage) will be paid within 30 days of approval.

Invoices missing any of the information listed above will not be accepted for payment but will be returned to the Contractor for correction.

3.15 Insurance

The Contractor shall be responsible for his work and every part thereof, and for all materials, tools, equipment, appliances, and properties of any and all description used in connection with this project.

The Contractor assumes all risks of direct and indirect damage or injury to the property of persons used or employed on or in connection with the work contracted for, and of all damage or injury to any person or property wherever located, resulting from any action, omission, commission or operation under the Contract, or in connection in any way whatsoever with the contracted work.

The Contractor shall, during the continuance of all work under the Contract, provide the following:

1. Maintain statutory Worker's Compensation and Employer's Liability insurance in an amount of not less than \$1,000,000.00 to protect the Contractor from any liability or damages for any injuries (including death and disability) to any of its employees, volunteers, or sub-contractors, including any and all liability or damage which may arise by virtue of any statute or law in force within the State of Georgia, or which may be herein after enacted.
2. The Contractor agrees to maintain Comprehensive General Liability insurance in an amount of not less than \$1,000,000.00 per occurrence to protect the Contractor, its sub-contractors, and the interest of the County, against any and all injuries to third parties, including bodily injury and personal injury, wherever located, resulting from any action or operation under the Contract or in connection with the contracted work. The General Liability insurance shall also include the Broad Form Property Damage Liability endorsement, in addition to coverage for explosion, collapse, and underground hazards, where required.
3. The Contractor agrees to maintain Automobile Liability Insurance in an amount of not less than \$500,000 per occurrence. Such insurance shall include coverage for owned, hired, and non-owned automobiles.
4. The Contractor further agrees to protect, defend, indemnify, and hold harmless Lumpkin County, its commissioners, officers, agents, and employees from and against any and all liability incurred whatsoever as a result of the work performed pursuant to the terms of this Bid.
5. The Contractor shall notify the County, in writing, sixty (60) days prior to any change in insurance coverage, including cancellation, non-renewal, etc. The Contractor shall furnish a new certificate prior to any change or cancellation date. The failure of the Contractor to deliver a new and valid certificate shall result in suspension of all payments until the new certificate is furnished. Additionally, contract work may be suspended until the new certificate is furnished to the County.
6. Insurance coverage required in these specifications shall be in force throughout the Contract term. Should the Contractor fail to provide acceptable evidence of current insurance within five (5) days of written notice at any time during the Contract term, the Owner shall have the absolute right to terminate the Contract without any further obligation to the Contractor. Further, the Contractor shall be responsible for the cost of procuring the uncompleted portion of the Contract at the time of termination.

7. Contractual and other Liability insurance provided under this Contract shall not contain a supervision, inspection, or engineering services exclusion that would preclude the County from supervising and/or inspecting the project as to the end result. The Contractor shall assume all on-the-job responsibilities as to the control of persons under its direct employment and of the sub-Contractors and any persons employed by the sub-Contractor.
8. The Contractor and all sub-Contractors shall comply with the Occupational Safety and Health Act of 1970, and amendments, as it may apply to this Contract.
9. If the Contractor does not meet the insurance requirements of the specifications, alternate insurance coverage satisfactory to the County may be considered. The Contractor shall be responsible for the costs of any and all alternate insurance coverage so obtained.

A "Certificate of Insurance" showing Lumpkin County Board of Commissioners as the Certificate Holder must be provided prior and incorporated as part of the award contract.

3.16 Project Coordination

The Contractor shall employ and assign only qualified and competent personnel to perform any service or task involved in this project. The Contractor shall designate one such person as a Project Manager, and the Project manager shall be deemed to be the Contractor's authorized representative, who shall be authorized to receive and accept any and all communications from the County. The County shall name a Project Manager who shall be authorized to generate, receive and accept communication as an authorized representative of the County.

The Contractor hereby agrees to replace any personnel or sub-contractor, at no cost or penalty to the County, if the County reasonably determines that the performance of any sub-contractor or personnel is unsatisfactory.

3.17 Accuracy of Work

The Contractor shall be responsible for the accuracy of the work performed and shall promptly correct its errors and omissions without additional compensation. Acceptance of the work by the County will not relieve the Contractor of the responsibility for subsequent correction of errors, the clarification of any ambiguities, or the costs associated with any additional work caused by negligent acts, errors, or omissions by the Contractor or latent defects in the products sold by the Contractor.

At any time during the execution of this project or during any phase of work performed by others based on data secured by the Contractor under this Agreement, the Contractor shall confer with the County for the purpose of interpreting the information supplied by the Contractor and to correct any errors or omissions. The above consultations, clarifications, and/or corrections shall be made without added compensation to the Contractor. The Contractor shall give immediate attention to these changes so there will be minimum delay to others. The Contractor shall be responsible for errors and omissions and save harmless the County and its agents as provided in this Agreement.

3.18 Ownership

Reports, plans, data, statistics, specifications, and other supporting records compiled or prepared in the performance of the Services required by this Contract, shall be the absolute property of the County and shall not be used by the Contractor for purposes unrelated to this Contract without the prior written approval of the County. Such original documents shall be turned over to the County upon completion of the contract except that Contractor shall have the right to retain copies of the same.

3.19 News Releases by Contractor

As a matter of policy, the County does not endorse the products or services of a Contractor. News releases concerning any resultant contract from this solicitation shall not be made by a Contractor without the prior written approval of the County. All proposed news releases shall be routed to the Lumpkin County Purchasing Director for review and approval.

3.20 Severability/Cancellation

It is understood and agreed by the parties hereto that if any part, term, or provision of this Contract is held illegal or in conflict with any law of the State, the validity of the remaining portions or provisions shall not be affected, and the rights and obligations of the parties shall be construed and enforced as if the Contract did not contain the particular part, term, or provisions held to be invalid.

The COUNTY and the Contractor agree to resolve through negotiation or mediation prior to filing any cause of action. The venue for any litigation arising from this contract shall be Lumpkin County, Georgia.

3.21 Drug Free Workplace

By submission of a Bid, the Contractor certifies that the provisions of Code Sections 5024-1 through 50-24-6 of the Official Code of Georgia Annotated, relating to the "Drug-free Workplace Act", have been complied with in full. The Contractor further certifies that:

1. A drug-free workplace will be provided for the Contractor's employees during performance of the contract; and
2. Each Contractor who hires a sub-Contractor to work in a drug-free work place shall secure from that sub-Contractor the following written certification:
3. As part of the subcontracting agreement with (Contractor's name), (Sub Contractor's name) certifies to the Contractor that a drug-free workplace will be provided for the sub Contractor's employees during the performance of this Contract pursuant to Paragraph (7) of Sub-section (b) of Code Section 50-24-3".
4. The Contractor further certifies that he will not engage in the unlawful manufacture, sale, distribution, dispensation, possession, or use of a controlled substance or marijuana during the performance of the Contract.

3.22 Assignment of Contractual Rights

It is agreed that the Contractor will not assign, transfer, convey, or otherwise dispose of a contract that may result from this bid or his right, title, or interest in or to the same, or any part thereof, without written consent of the County.

3.23 Indemnity

To the fullest extent permitted by law, the Contractor will indemnify, defend, and hold Lumpkin County harmless from and against any and all claims, damages, losses, and expenses, including, but not limited to, fees and charges of attorneys and court and arbitration costs, arising out of or resulting from the negligent acts, negligent omissions, willful misconduct, or reckless misconduct of the Contractor or anyone for whom the Contractor is responsible.

3.24 Non-Collusive Bidding

By submitting a response to this Invitation to Bid, the Bidder represents and warrants that such bid is genuine and not a sham or collusive or made in the interest or on behalf of any person not therein named and that the Bidder has not directly or indirectly induced or solicited any other vendor to put in a sham bid, or any other person or company to refrain from submitting and that the Bidder has not in any manner sought by collusion to secure to that vendor any advantage over any other vendor.

3.25 Georgia Security and Immigration Compliance

To comply with the State of Georgia's Security and Immigration Compliance Act, all contractors must comply with regulations by completing the provided affidavits relative to the Compliance Act. All applicable affidavits have been included with this Invitation to Bid and must be signed and provided with the Bid submission.

3.26 Appropriation of Funds

The initial contract and any continuation contract(s) shall terminate immediately and absolutely at any such time as there are no appropriated and otherwise unencumbered funds available to satisfy the County's obligations under said contract(s).

3.27 Documents Deemed Part of Contract

The entire Invitation to Bid, addenda (if any) and entire Bid submitted by the Bidder shall be deemed part of the contract.

BIDDER'S CERTIFICATION

ASPHALT LEVELING AND RESURFACING OF COUNTY ROADS PROJECT# 2018-001-ITB

Date of Bid _____

I certify that this Bid is submitted without prior understanding, agreement or connection with any corporation, firm or person submitting a Bid for the same goods/services and is in all respects fair and without collusion or fraud. I understand that collusive bidding is a violation of State and Federal law and can result in fines, prison sentences and civil damages awards. I agree to abide by all terms and conditions stated of this bid document and certify that I am authorized to sign this bid for the bidder.

I acknowledge that this Project will be constructed in English units.

I certify that I have carefully examined the Plans for this Project and the Standard Specifications, 2013 Edition, and the Supplemental Specifications and Special Provisions included in and made a part of this Bid, and have also personally examined the site of the work. On the basis of the said Scope of Work and Specifications, I propose to furnish all necessary machinery, tools, apparatus and other means of construction, and do all the work and furnish all the materials in the manner specified.

I understand the quantities mentioned are approximate only and are subject to either increase or decrease and hereby propose to perform any increased or decreased quantities of work or extra work on the basis provided for in the Specifications.

I also hereby agree that Lumpkin County would suffer damages in a sum equal to at least the amount of the enclosed Bid Guaranty, in the event my Bid should be accepted and a Contract tendered me there under and I should refuse to execute same and furnish bond as herein required, in consideration of which I hereby agree that, in the event of such failure on my part to execute said Contract and furnish bond within fifteen (15) days after the date of the letter transmitting the Contract to me, the amount of said Bid Guaranty shall be and is hereby, forfeited to Lumpkin County, as liquidated damages as the result of such failure on my part.

I further agree to execute a Contract prepared by Lumpkin County as soon as the work is awarded to me, and to begin and complete the work within the time limit provided. I also propose to furnish the Bonds as required by the Bid Documents and laws of the State of Georgia. Such bond(s) shall not only serve to guarantee the completion of the work on my part, but also to guarantee the excellence of both workmanship and materials until the work is finally accepted, as well as to fully comply with all the laws of the State of Georgia and Lumpkin County.

LUMPKIN COUNTY CONTRACT SCHEDULE				
VARIOUS COUNTY ROADS				
CONTRACT ID: 2018-001				
PROJECT: LMIG-1-187-LUMPKIN				
LINE NO	ITEM DESCRIPTION	ESTIMATED QUANTITY AND UNITS	UNIT PRICE DOLLARS/CENTS	TOTAL DOLLARS/CENTS
0005	150-3110 Traffic Control for LMIG-01	Lump Sum		
0010	402-1812 Recycled Asph. Conc. Leveling incl. Bitum Matl. And H Lime	500 Ton		
0015	402-3130 Recycled Asph. Conc. 12.5 MM Super Pave Gp 2 only incl. Bitum Matl. And H lime	7704 Ton		
0020	413-1000 Bitum. Tack Coat	6000 GAL		
0025	652- Solid Traffic Stripe, 5" White	10.2 LM		
0030	652- Solid Traffic Stripe, 5" Yellow	10.2 LM		
0035	652- Skip Traffic Stripe, 5" White	0.05 GLM		
0040	652- Skip Traffic Stripe, 5" Yellow	0.05 GLM		
			Total Bid	

**CONTRACT
FOR
ASPHALT LEVELING AND RESURFACING OF VARIOUS COUNTY ROADS
PROJECT # 2018-001
LMIG-01-187 LUMPKIN**

This agreement is made and entered into between the governing authority of Lumpkin County, hereinafter referred to as “Lumpkin County”, a political subdivision of the State of Georgia, and _____, hereinafter referred to as “Contractor”.

Whereas, in consideration of the mutual benefits accruing to each party, the parties hereby agree as follows:

A. Summary of Work and Payment:

1. Contractor shall perform leveling and resurfacing with asphalt concrete of the county roads listed in the Scope of Work & Specifications section of the Invitation to Bid issued January 31, 2018, for this project. All work will be done in accordance with the 2013 State of Georgia Standard Specifications as modified by the Special Provisions contained in the Bid Documents for this project.

Lumpkin County personnel will be supervising construction of this project but will also be subject to inspections and audits by the Georgia Department of Transportation.

2. Contractor shall be authorized to begin work upon the issuance of a Notice to Proceed from Lumpkin County. All work shall be completed no later than 180 calendar days from the day the Notice to Proceed is issued.

3. The Contractor shall employ and assign only qualified and competent personnel to perform any service or task involved in this project. The Contractor shall designate one such person as a Project Manager, and the Project Manager shall be deemed to be the Contractor’s authorized representative, who shall be authorized to receive and accept any and all communications from the County. The County shall name a Project Manager who shall be authorized to generate, receive and accept communication as an authorized representative of the County.

4. The Contractor hereby agrees to replace any personnel or sub-contractor, at no cost or penalty to the County, if the County reasonably determines that the performance of any sub-contractor or personnel is unsatisfactory.

5. Contractor shall be paid for work performed under this Contract on a unit price basis as follows:

<u>Line No.:</u>	<u>Item Description:</u>	<u>Unit Price:</u>
0005	150-3110 Traffic Control (Lump Sum)	\$
0010	402-1812 Recycled Asph. Conc. Leveling including Bitum Matl. And H lime (Ton)	\$
0015	402-3130 Recycled Ashp. 12.5 MM Super Pave, GP 2 including Bitum Matl. and H lime (Ton)	\$
0020	413-1000 Bitum Tack Coat (Gal)	\$
0025	652 Solid Traffic Stripe, 5" White (LM)	\$
0030	652 Solid Traffic Stripe, 5" Yellow (LM)	\$
0035	652 Skip Traffic Stripe, 5" White (GLM)	\$
0040	652 Skip Traffic Stripe, 5" Yellow (GLM)	\$

Payment shall be made according to the terms contained in the Invitation to Bid.

B. Bonds:

Contractor shall, prior to commencing work, provide and shall maintain, during the continuance of all work under the Contract, all Bonds required in the Invitation to Bid.

C. Liability:

Contractor shall be responsible for his work and every part thereof, and for all materials, tools, equipment, appliances, and properties of any and all description used in connection with this Contract.

Contractor assumes all risks of direct and indirect damage or injury to the property of persons used or employed on or in connection with the work contracted for, and of all damage or injury to any person or property wherever located, resulting from any action, omission, commission or operation under the Contract, or in connection in any way whatsoever with the contracted work.

Contractor shall be liable for any collateral damage (such as broken curbs, crushed sidewalks, broken water meters, etc.) caused as a result of its work under this Contract. Contractor shall restore and/or repair, at Contractor's cost, any and all collateral damage, including, but not limited to, damage to infrastructure, back to its pre-existing condition if the damage was caused by Contractor's activities.

D. Insurance:

The Contractor shall, during the continuance of all work under the Contract, provide and maintain all insurance policies required by the Invitation to Bid.

E. Assignment of Contractual Rights and Subcontracting:

It is agreed that the Contractor will not assign, transfer, convey, or otherwise dispose of this contract or its right, title, or interest in or to the same, or any part thereof, without written consent of the County.

Contractor shall not subcontract any work without the express written consent of the County. The County must approve all subcontractors.

F. Indemnity:

To the fullest extent permitted by law, the Contractor will indemnify, defend, and hold Lumpkin County harmless from and against any and all claims, damages, losses, and expenses, including, but not limited to, fees and charges of attorneys and court and arbitration costs, arising out of or resulting from the negligent acts, negligent omissions, willful misconduct, or reckless misconduct of the Contractor or anyone for whom the Contractor is responsible.

G. Documents Deemed Part of Contract:

Unless otherwise modified by this Contract, Lumpkin County's Invitation to Bid issued January 31 2018, and any addendums issued thereto, and the Project Manual containing Specifications and Special Provisions shall be deemed part of the contract. No documentation or information provided by the Contractor shall be deemed part of the contract unless expressly incorporated herein.

H. Severability:

It is understood and agreed by the parties hereto that if any part, term, or provision of this Contract is held illegal or in conflict with any law of the State or Georgia, the validity of the remaining portions or provisions shall not be affected, and the rights and obligations of the parties shall be construed and enforced as if the Contract did not contain the particular part, term, or provisions held to be invalid.

I. Dispute Resolution:

Lumpkin County and the Contractor agree to resolve through negotiation or mediation prior to filing any cause of action. The venue for any litigation arising from this contract shall be Lumpkin County, Georgia.

J. Cancellation:

Lumpkin County reserves the right to terminate the contract immediately in the event that the Contractor discontinues or abandons operations, is adjudged bankrupt, or is reorganized under any bankruptcy law; or fails to keep in force any required insurance policies or bonds.

Failure of the Contractor to comply with any section or part of the contract will be considered grounds for immediate termination of the contract by the County without penalty to Lumpkin County. Lumpkin County shall pay for services rendered up to the point of termination.

Notwithstanding anything to the contrary contained herein, the County may, without prejudice to any other rights it may have, terminate the contract for convenience and without cause, by giving thirty (30) days written notice to the Contractor.

If the termination clause is used by the County, the Contractor will be paid by the County for all scheduled work completed satisfactorily by the Contractor up to the termination date set forth in the written termination notice.

K. Safe Working Environment and Drug Free Workplace

Contractor shall provide a safe working environment.

Contractor certifies that the provisions of Code Sections 5024-1 through 50-24-6 of the Official Code of Georgia Annotated, relating to the "Drug-free Workplace Act", have been complied with in full. The Contractor further certifies that:

1. A drug-free workplace will be provided for the Contractor's employees during performance of the contract; and
2. If Contractor hires a Sub Contractor to work in a drug-free work place, Contractor shall secure from that Sub Contractor the following written certification:

As part of the subcontracting agreement with (Contractor's name), (Sub Contractor's name) certifies to the Contractor that a drug-free workplace will be provided for the Sub Contractor's employees during the performance of this Contract pursuant to Paragraph (7) of Sub-section (b) of Code Section 50-24-3".

The Contractor further certifies that it will not engage in the unlawful manufacture, sale, distribution, dispensation, possession, or use of a controlled substance or marijuana during the performance of the Contract.

L. Amendments or Modifications:

All contract amendments or modifications must be in writing and signed by all parties.

M. Notices:

Any notice, order, instruction, claim, or other written communication required or permitted under this contract shall be deemed to have been delivered or received:

1. Upon personal delivery to the Contractor or his authorized representative, which delivery may be accomplished by in person hand delivery, via bona fide overnight express service or telephonic facsimile transmission; or
2. Three (3) days after depositing in the United States mail a letter which is either certified or registered, with return receipt requested, addressed to the Contractor at the following address:

and to Lumpkin County at the following address:

Lumpkin County Board of Commissioners
 Attn: Stan Kelly, County Manager
 99 Courthouse Hill, Ste A
 Dahlonega, Georgia 30533.

This Contract is made and entered into this _____ day of _____, 2018.

Lumpkin County:

Chris Dockery, Chairman
 Lumpkin County Board of Commissioners

Contractor:

(Printed Company Name)
 By:
 Printed Name:
 Title:

Attest:
 Kathleen Walker
 Lumpkin County Clerk

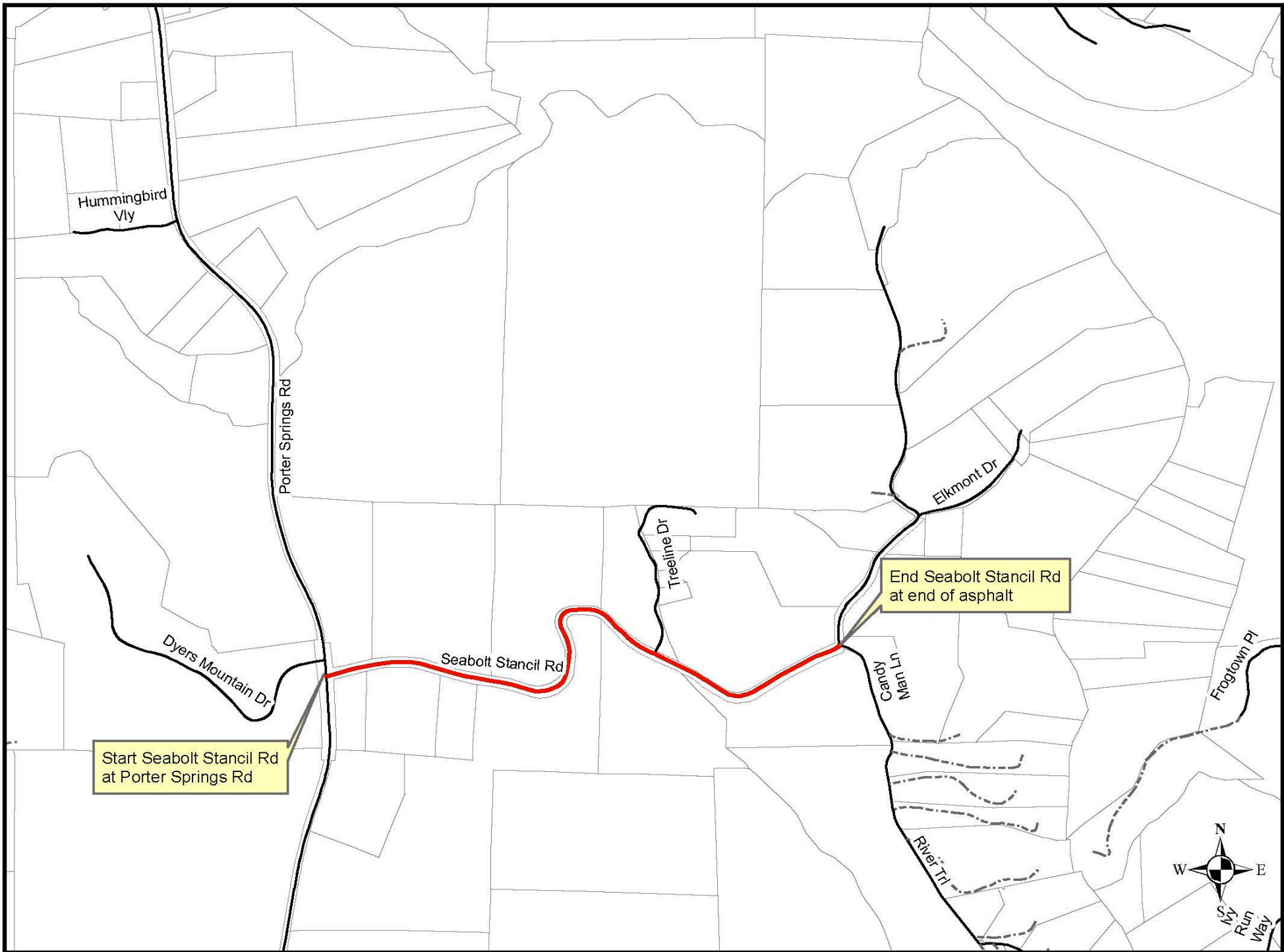

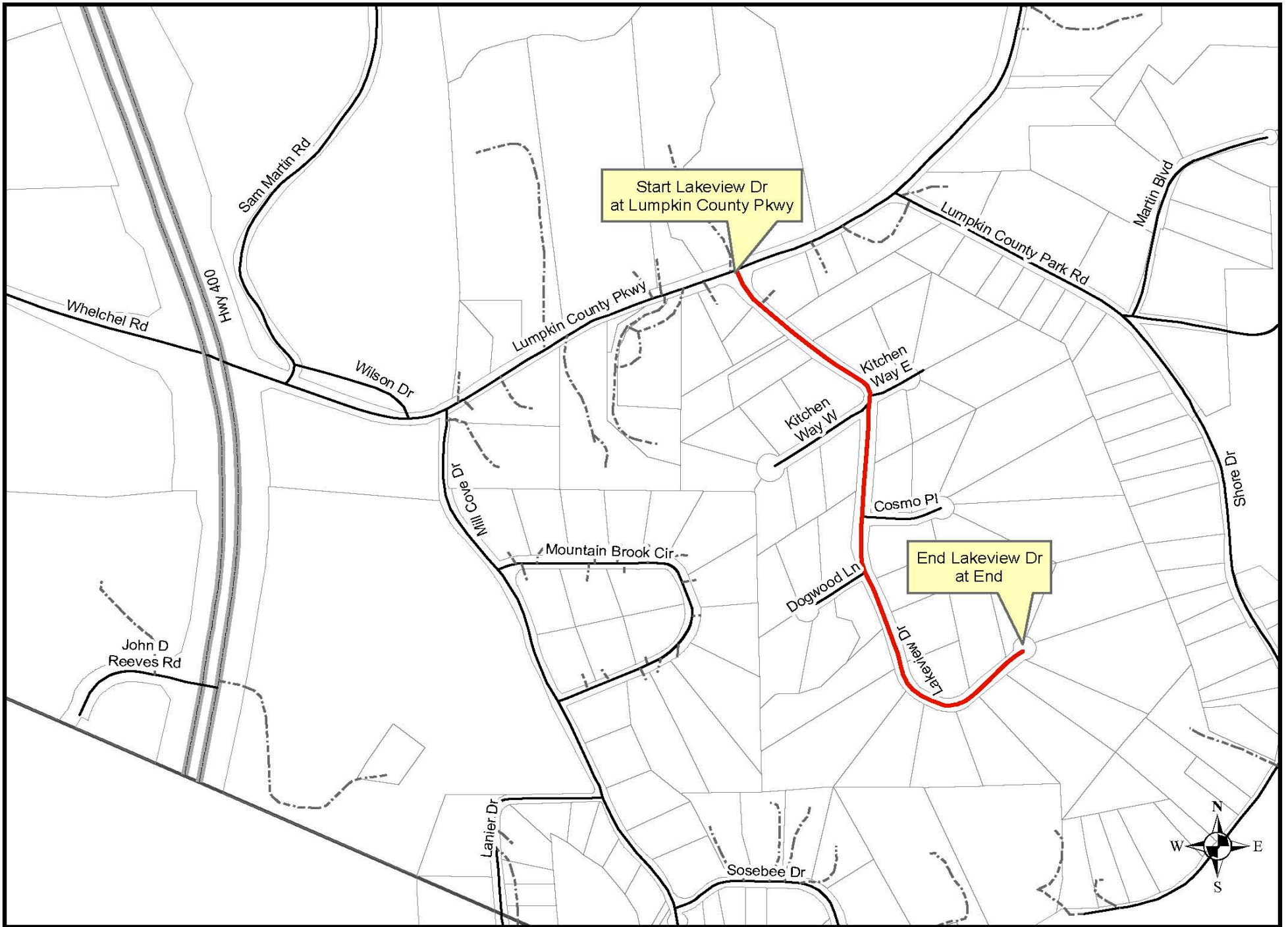

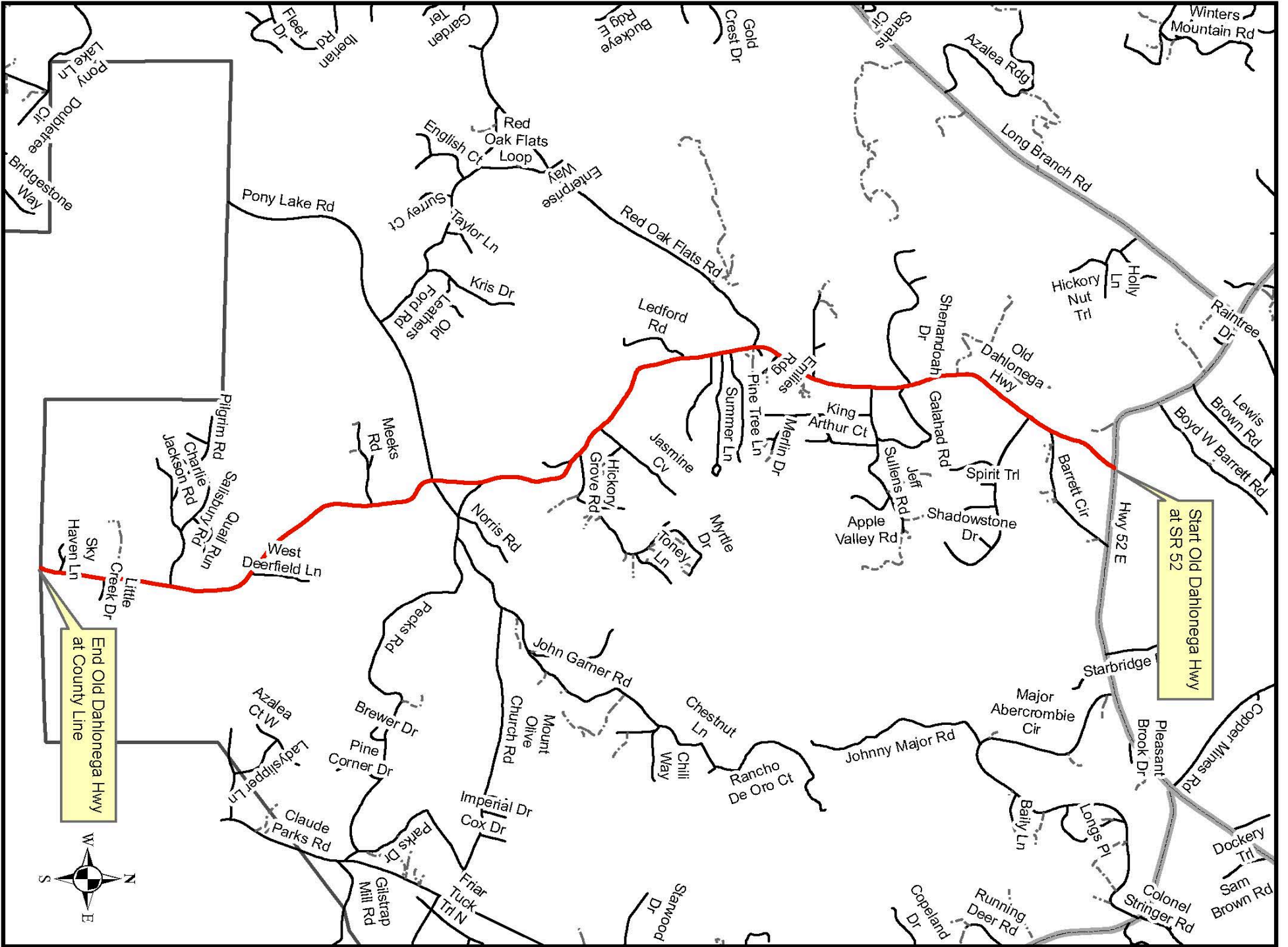

LMIG TYPICAL RESURFACING SECTION

(LET)

CURB AND GUTTER DETAIL

DETAIL FOR FEATHERING SURFACING CURB AND GUTTER

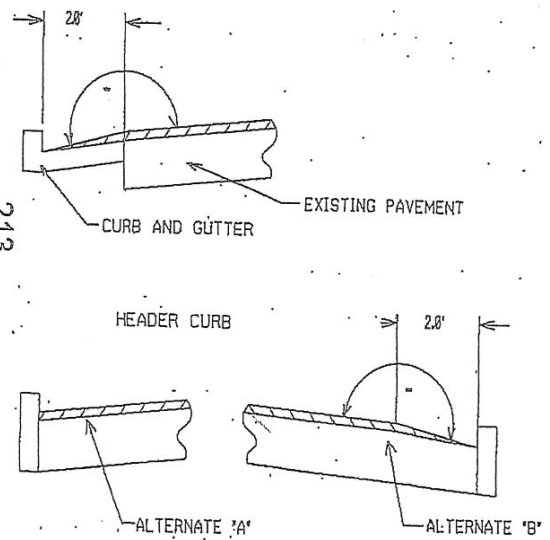

213

NOTE: METHOD OF FEATHERING AT PAVEMENT EDGE ALTERNATE A OR ALTERNATE B SHALL BE DETERMINED BY THE ENGINEER. UNDER NORMAL CONDITIONS, ALTERNATE A SHALL BE USED FOR FEATHERING UNLESS RESURFACING HAS REDUCED THE EFFECTIVE HEIGHT OF THE EXISTING CURB TYPE FACILITY. IN THIS EVENT, ALTERNATE B SHALL BE USED.

NOTE: THE ALGEBRAIC DIFFERENCE BETWEEN THE NEW RIDING SURFACE AND THE FEATHERING IN THE CURB AND GUTTER SHALL NOT EXCEED 7.0%.

7/04

IF CURB & GUTTER IS EXISTING, THEN REFER TO CURB & GUTTER DETAIL

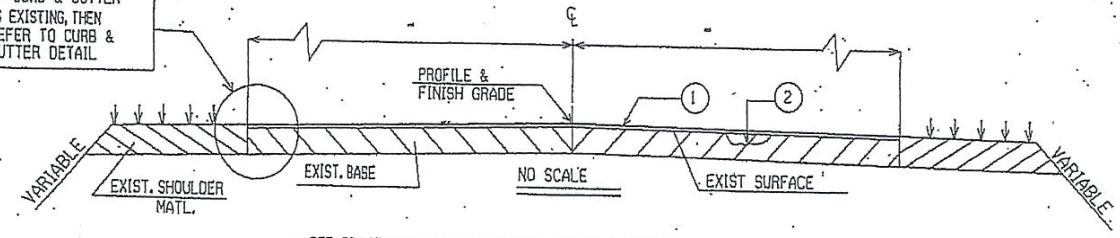

* SEE PROJECT REPORT SHEET(S) FOR PAVEMENT WIDTHS

- REQ'D ① 175 LBS PER SY ASPH CONC 2.5 MM SUPERPAVE, TP I, GP1 OR BLEND, 1, INCL BITUM MATL & H. LIME
- REQ'D ② ASPH. CONC LEVELING, INCL BITUM MATL & H. LIME TO BE PLACED AS DIRECTED BY THE ENGINEER.

NOTE: THE LOCAL GOVERNMENT WILL CERTIFY ALL NECESSARY R/W, REMOVE OR ADJUST ALL UTILITIES, AND DO THE NECESSARY PATCHING, AS DIRECTED BY THE ENGINEER, AT NO COST TO THE DEPARTMENT OF TRANSPORTATION.

NOTE: THE WIDTH OF PAVING OF TURNOUTS FOR SIDEROADS AND DRIVES SHALL BE AS REQUIRED TO PROVIDE A SMOOTH AND WELL DRAINED TRANSITION TO AND FROM PUBLIC ROADS AND DRIVEWAYS, AS APPROVED BY THE ENGINEER.

THIS TYPICAL SECTION APPLIES TO PRIORITY #'(S)
AS SHOWN ON THE LMIG PROJECT REPORT SHEET(S).

ALL

PROJECT NO.	<u>LMIG 1 (2017)</u>
COUNTY	<u>Lumpkin Co.</u>
CITY	



VENDOR'S CHECKLIST AND BID SUBMITTAL PACKET

Company Name: _____

Please indicate you have completed the following documentation; and submit them in the following order

- Information Form
- Execution of Proposal Form
- Price Proposal Form
- Bid Bonds
- Certification and Non-Collusion Form
- Drug-Free Workplace Form
- Addenda Acknowledgment Form
- Georgia's Security and Immigration Compliance Act Affidavit
- SAVE Affidavit
- Completed W9

Authorized Signature

Title

Print Name

Date

THIS PAGE MUST BE COMPLETED AND SUBMITTED WITH BID



INFORMATION FORM

1. Legal Business Name _____
2. Street Address _____
3. City, State & Zip _____
4. Type of Business: State of Registration: _____
(Association, Corporation, Partnership, Limited Liability Company, etc.)
5. Name & Title of Authorized Signer: _____
6. Primary Contact _____
7. Phone Fax _____
8. E-mail _____
9. Company Website _____
10. Has your company ever been debarred from doing business with any federal, state or local agency?

Yes _____ No _____

If yes, please state the agency name, dates and reason for debarment.

THIS PAGE MUST BE COMPLETED AND SUBMITTED WITH BID



EXECUTION OF PROPOSAL FORM

DATE: _____

The potential Contractor certifies the following by placing an "X" in all blank spaces:

_____ That this proposal was signed by an authorized representative of the firm.

_____ That the potential Contractor has determined the cost and availability of all materials and supplies associated with performing the services outlined herein.

_____ That all labor costs associated with this project have been determined, including all direct and indirect costs.

_____ That the potential Contractor agrees to the conditions as set forth in this Invitation to Bid with no exceptions.

Therefore, in compliance with the foregoing **Invitation for Bids**, and subject to all terms and conditions thereof, the undersigned offers and agrees, if this proposal is accepted within sixty (60) days from the date of the opening, to furnish the services for the prices quoted within the timeframe required.

Business Name

Authorized Signature

Date

Typed Name & Title

THIS PAGE MUST BE COMPLETED AND SUBMITTED AS A PART OF YOUR BID



PRICE PROPOSAL FORM

Company Name: _____

Total Bid: _____

I certify the above bid as all-inclusive and final per document specifications.

Authorized Signature **Title**

Print Name **Title**

THIS PAGE MUST BE COMPLETED AND SUBMITTED AS A PART OF YOUR BID



CERTIFICATION AND NON-COLLUSION FORM

I _____ certify that this proposal is made without prior understanding, agreement or connection with any corporation, firm or person submitting a proposal for the same services and is in all respects fair and without collusion or fraud. I understand that collusive bidding is a violation of state and Federal law and can result in fines, prison sentences and civil damages awards.

I certify that this proposal has been prepared independently and the price submitted will not be disclosed to another person.

I certify that there has been no contact or communication by the proposer or the proposer's associates with any County staff, or elected officials since the date this **BID #2018-001 ITB ASPHALT LEVELING AND RESURFACING OF VARIOUS COUNTY ROADS** was issued except: 1) through the Purchasing Department 2) at the Pre-Bid Conference (if applicable) or 3) as provided by existing work agreement(s). **The County reserves the right to reject the bid submitted by any proposer violating this provision.**

I agree to abide by all conditions of this bid and certify that I am authorized to sign this proposal.

COMPANY NAME: _____

Authorized Representative (Signature)

Date

Authorized Representative/Title

(Print or Type)

THIS PAGE MUST BE COMPLETED AND SUBMITTED AS A PART OF YOUR BID



DRUG- FREE WORKPLACE FORM

I hereby certify that I am a principle and duly authorized representative of: _____

Whose address is: _____

And it is also that:

1. The provisions of Section § 50.24.1 through § 50.24.6 of the Official Code of Georgia Annotated relating to the "Drug Free Workplace Act" and have been complied with in full, and
2. A drug free workplace will be provided for the CONTRACTOR'S employees during the performance of the contract; and,
3. Each subcontractor hired by the CONTRACTOR shall be required to ensure that the subcontractor's employees are provided a drug free workplace. The CONTRACTOR shall secure from that subcontractor the following written certification: "As part of the subcontracting agreement with

certifies to the CONTRACTOR that a drug free workplace will be provided for the subcontractor's employees during the performance of this contract pursuant to paragraph (7) of subsection (b) of the Official Code of Georgia Annotated Section § 50.24.3"; and,

4. It is certified that the undersigned will not engage in unlawful manufacture, sale, distribution, dispensation, possession, or use of a controlled substance or marijuana during the performance of the contract.

Signature

Date

THIS PAGE MUST BE COMPLETED AND SUBMITTED AS A PART OF YOUR BID



ADDENDA ACKNOWLEDGEMENT FORM

The vendor has examined and carefully studied the Invitation for Bid and the following Addenda, receipt of all of which is hereby acknowledged:

Addendum No. _____

Addendum No. _____

Addendum No. _____

Addendum No. _____

Authorized Representative (Signature)

Date

Authorized Representative/Title
(Print or Type)

Vendors must acknowledge any issued addenda. Proposals which fail to acknowledge the vendor's receipt of any addendum will result in the rejection of the offer if the addendum contained information which substantively changes the Owner's requirements.

THIS PAGE MUST BE COMPLETED AND SUBMITTED AS A PART OF YOUR BID

Georgia Security & Immigration Compliance (GSIC) Act Affidavit

As per the Georgia Senate Bill 529 and Senate Bill 447, the Georgia Department of Labor has promulgated new rules for the implementation of Section 2. O.C.G.A. §13-10-91 and Chapter 300-10-01-.02 state that no Georgia Public Employer shall enter into a contract for *the physical performance of services within the State of Georgia* unless the Contractor registers and participates in a federal work authorization program to verify the work eligibility information of all of its new employees.

The Employment Eligibility Verification “E-Verify” site operated by the U.S. Citizenship and Immigration Services Bureau of the U.S. Department of Homeland Security is the electronic federal work authorization program to be utilized for these purposes.

The website is <https://e-verify.uscis.gov/enroll/>

By executing the attached Contractor Affidavit, Contractor verifies its compliance with O.C.G.A. §13-10-91 stating affirmatively that the individual, firm or corporation which is contracting with the Lumpkin County Board of Commissioners has registered and is participating in this federal work authorization program in accordance with the applicability provisions and deadlines established in this Statute.

Contractor further agrees that should it employ or contract with any Sub-Contractor(s) for the physical performance of services pursuant to the contract with the Lumpkin County Board of Commissioners, Contractor will secure from the Sub-Contractor(s) verification of compliance with O.C.G.A. §13-10-91 on a Sub-Contractor Affidavit and shall provide a copy of each such verification to the Lumpkin County Board of Commissioners at the time the Sub-Contractor(s) is retained to perform such services.

PLEASE COMPLETE THE ATTACHED AFFIDAVIT AND RETURN IT TO:

Ryan McDuffie
Lumpkin County Purchasing Agent
99 Courthouse Hill, Suite D
Dahlonega, GA 30533
Fax: (706) 482-2201
Email: ryan.mcduffie@lumpkincounty.gov

LUMPKIN COUNTY BOARD OF COMMISSIONERS
SAVE Affidavit

(Systematic Alien Verification for Entitlements)

Affidavit for a Public Benefit as required by the Georgia Immigration Reform and Enforcement Act of 2011

By executing this affidavit under oath, as an applicant for a public benefit as referenced in the Georgia Illegal Immigration Reform and Enforcement Act of 2011 [O.C.G.A. § 50-36-1(e)(2)], I am stating the following:

_____ **I am a United States citizen; or**

_____ **I am a legal permanent resident of the United States*; or**

_____ **I am an otherwise qualified alien or non-immigrant under the Federal Immigration and Nationality Act 18 years of age or older and lawfully present in the United States.***

*Alien registration number for non-citizens issued by the Department of Homeland Security or other federal immigration agency is: _____

At least one secure and verifiable document for identification purposes must be provided as required by O.C.G.A. § 50-36-1 (e) (1). See list on page 2 of this document.

In making the above representation under oath, I understand that any person who knowingly and willfully makes a false, fictitious, or fraudulent statement or representation in an affidavit shall be guilty of a violation of Code Section 16-10-20 of the Official Code of Georgia and face criminal penalties as allowed by such criminal statute.

Applying on behalf/Name of associated business

Signature of Applicant

Date

Printed Name

SUBSCRIBED AND SWORN BEFORE ME ON THIS
THE _____ DAY OF _____ 20__

Notary Public

[NOTARY SEAL]

My Commission Expires: _____

***NOTE:** O.C.G.A. 50-36-1(e)(2) requires that aliens under the Federal Immigration and Nationality Act, Title 8 U.S.C., as amended, provide their alien registration number. Because legal permanent residents are included in the federal definition of "alien", legal permanent residents must also provide their alien registration number.

THIS PAGE MUST BE COMPLETED AND SUBMITTED AS A PART OF YOUR BID

SECURE AND VERIFIABLE DOCUMENTS UNDER O.C.G.A. §50-36-2

[Issued August 1, 2011 by the Office of the Attorney General, Georgia]

The following list of secure and verifiable documents, published under the authority of O.C.G.A. §50-36-2, contains documents that are verifiable for identification purposes, and documents on this list may not necessarily be indicative of residency or immigration status.

INDICATE AND ATTACH A COPY OF THE DOCUMENT (front and back)

- United States passport or passport card
- United States military identification card
- Merchant Mariner Document or Merchant Mariner Credential issued by the United States Coast Guard
- Secure Electronic Network for Travelers Rapid Inspection (SENTRI) card
- Driver's license issued by one of the United States, the District of Columbia, the Commonwealth of the Northern Marianas Islands, the United States Virgin Island, American Samoa, or the Swain Islands, provided that it contains a photograph of the bearer or lists sufficient identifying information regarding the bearer, such as name, date of birth gender, height, eye color, and address to enable the identification of the bearer.
- Identification card issued by one of the United States, the District of Columbia, the Commonwealth of Puerto Rico, Guam, the Commonwealth of the Northern Marianas Islands, the United States Virgin Island, American Samoa, or the Swain Islands, provided that it contains a photograph of the bearer or lists sufficient identifying information regarding the bearer, such as name, date of birth gender, height, eye color, and address to enable the identification of the bearer.
- Tribal identification card issued by one of the United States, the District of Columbia, the Commonwealth of Puerto Rico, Guam, the Commonwealth of the Northern Marianas Islands, the United States Virgin Island, American Samoa, or the Swain Islands, provided that it contains a photograph of the bearer or lists sufficient identifying information regarding the bearer, such as name, date of birth gender, height, eye color, and address to enable the identification of the bearer.
- Passport issued by a foreign government
- Free and Secure Trade (FAST) card
- NEXUS card
- United States Permanent Resident Card or Alien Registration Receipt Card
- Employment Authorization Document that contains a photograph of the bearer.
- Certificate of Citizenship issued by the United States Department of Citizenship and Immigration Services (USCIS) [Form N-560 or FormN-561]
- Certificate of Naturalization issued by the United States Department of Citizenship and Immigration Services (USCIS) [Form N-550 or FormN-570]

THIS PAGE MUST BE COMPLETED AND SUBMITTED AS A PART OF YOUR BID

**IMMIGRATION AND SECURITY FORM
(GEORGIA SECURITY AND IMMIGRATION COMPLIANCE ACT AFFIDAVIT**

CONTRACTOR AFFIDAVIT

By executing this affidavit, the undersigned Contractor verifies its compliance with O.C.G.A. §13-10-91, stating affirmatively that the Contractor identified above has registered with and is participating in a federal work authorization program*, in accordance with the applicability provisions and deadlines established in O.C.G.A. 13-10-91.

The undersigned further agrees that, should it employ or contract with any subcontractor(s) in connection with the physical performance of services pursuant to this contract with the County, Contractor will secure from such subcontractor(s) similar verification of compliance with O.C.G.A. § 13-10-91 on the attached Subcontractor Affidavit. Contractor further agrees to maintain records of such compliance and provide a copy of each such verification to the County at the time the subcontractor(s) is retained to perform such service.

EEV / E-Verify™ Company Identification Number

BY: Authorized Officer or Agent
(Contractor Name)

Date

Title of Authorized Officer or Agent of Contractor

Printed Name of Authorized Officer or Agent

SUBSCRIBED AND SWORN BEFORE ME ON THIS
THE DAY OF 20____

(NOTARY SEAL)

Notary Public

My Commission Expires: _____

*any of the electronic verification of work authorization programs operated by the United States Department of Homeland Security or any equivalent federal work authorization program operated by the United States Department of Homeland Security to verify information of newly hired employees, pursuant to the Immigration Reform and Control Act of 1986 (IRCA), P.L. 99-

THIS PAGE MUST BE COMPLETED AND SUBMITTED AS A PART OF YOUR BID

**IMMIGRATION AND SECURITY FORM
(GEORGIA SECURITY AND IMMIGRATION COMPLIANCE ACT AFFIDAVIT)**

SUBCONTRACTOR AFFIDAVIT

By executing this affidavit, the undersigned Subcontractor verifies its compliance with O.C.G.A. §13-10-91, stating affirmatively that the Subcontractor which is engaged in the physical performance of services under a contract with the Contractor identified above on behalf of the County identified above has registered with and is participating in a federal work authorization program*, in accordance with the applicability provisions and deadlines established in O.C.G.A. 13-10-91.

EEV / E-Verify™ Company Identification Number

BY: Authorized Officer or Agent Date
(Subcontractor Name)

Title of Authorized Officer or Agent of Contractor

Printed Name of Authorized Officer or Agent
SUBSCRIBED AND SWORN BEFORE ME ON
THIS THE ____ DAY OF _____ 20____

Notary Public

My Commission Expires:

*any of the electronic verification of work authorization programs operated by the United States Department of Homeland Security or any equivalent federal work authorization program operated by the United States Department of Homeland security to verify information of newly hired employees, pursuant to the Immigration Reform and Control Act of 1986 (IRCA), P.L. 99-603

THIS PAGE MUST BE COMPLETED AND SUBMITTED AS A PART OF YOUR BID

Private Employer Exemption Affidavit Pursuant to O.C.G.A § 36-60-6(d)

By executing this affidavit, the undersigned private employer verifies that it is exempt from compliance with O.C.G.A §36-60-6, stating affirmatively that the individual, firm or corporation employs fewer than eleven employees and therefore, is not required to register with and/or utilize the federal work authorization program commonly known as E-Verify, or any subsequent program in accordance with the applicable provisions and deadlines established in O.C.G.A § 13-10-90.

Signature of Exempt Private Employer

Printed Name of Exempt Private Employer

I hereby declare under penalty of perjury that the foregoing is true and correct.

Signature of Authorized Officer or Agent

Printed Name and Title of Authorized Officer or Agent

SUBSCRIBED AND SWORN BEFORE ME ON THIS THE _____ DAY OF _____, 201____.

NOTARY PUBLIC

My Commission Expires: _____

Request for Taxpayer Identification Number and Certification

**Give Form to
the requester.
Do not send to
the IRS.**

Print or type See Specific Instructions on page 2.	Name (as shown on your income tax return)		
	Business name/disregarded entity name, if different from above		
	Check appropriate box for federal tax classification: Individual/sole proprietor C Corporation S Corporation Partnership Trust/estate Limited liability company. Enter the tax classification (C=C corporation, S=S corporation, P=partnership) ▶		Exemptions (see instructions): Exempt payee code (if any) Exemption from FATCA reporting code (if any)
	Address (number, street, and apt. or suite no.)		Requester's name and address (optional)
	City, state, and ZIP code		
List account number(s) here (optional)			

Part I Taxpayer Identification Number (TIN)

Enter your TIN in the appropriate box. The TIN provided must match the name given on the "Name" line to avoid backup withholding. For individuals, this is your social security number (SSN). However, for a resident alien, sole proprietor, or disregarded entity, see the Part I instructions on page 3. For other identification number (EIN). If you do not have a number, see *How to get a TIN* on page 3.

Social security number
[Redacted]

Note. If the account is in more than one name, see the chart on page 4 for guidelines on whose number to enter.

Employer identification number								
				-				

Part II Certification

Under penalties of perjury, I certify that:

1. The number shown on this form is my correct taxpayer identification number (or I am waiting for a number to be issued to me), and
2. I am not subject to backup withholding because: (a) I am exempt from backup withholding, or (b) I have not been notified by the Internal Revenue Service (IRS) that I am subject to backup withholding as a result of a failure to report all interest or dividends, or (c) the IRS has notified me that I am no longer subject to backup withholding, and
3. I am a U.S. citizen or other U.S. person (defined below), and
4. The FATCA code(s) entered on this form (if any) indicating that I am exempt from FATCA reporting is correct.

Certification instructions. You must cross out item 2 above if you have been notified by the IRS that you are currently subject to backup withholding because you have failed to report all interest and dividends on your tax return. For real estate transactions, item 2 does not apply. For mortgage interest paid, acquisition or abandonment of secured property, cancellation of debt, contributions to an individual retirement arrangement (IRA), and generally, payments other than interest and dividends, you are not required to sign the certification, but you must provide your correct TIN. See the instructions on page 3.

Sig n	Signature of U.S. person	Date ▶

General Instructions

Section references are to the Internal Revenue Code unless otherwise noted.
Future developments. The IRS has created a page on IRS.gov for information about Form W-9, at www.irs.gov/w9. Information about any future developments affecting Form W-9 (such as legislation enacted after we release it) will be posted on that page.

Purpose of Form

A person who is required to file an information return with the IRS must obtain your correct taxpayer identification number (TIN) to report, for example, income paid to you, payments made to you in settlement of payment card and third party network transactions, real estate transactions, mortgage interest you paid, acquisition or abandonment of secured property, cancellation of debt, or contributions you made to an IRA.

Use Form W-9 only if you are a U.S. person (including a resident alien), to provide your correct TIN to the person requesting it (the requester) and, when applicable, to:

1. Certify that the TIN you are giving is correct (or you are waiting for a number to be issued),
2. Certify that you are not subject to backup withholding, or
3. Claim exemption from backup withholding if you are a U.S. exempt payee. If applicable, you are also certifying that as a U.S. person, your allocable share of any partnership income from a U.S. trade or business is not subject to the

withholding tax on foreign partners' share of effectively connected income, and

4. Certify that FATCA code(s) entered on this form (if any) indicating that you are exempt from the FATCA reporting, is correct.

Note. If you are a U.S. person and a requester gives you a form other than Form W-9 to request your TIN, you must use the requester's form if it is substantially similar to this Form W-9.

Definition of a U.S. person. For federal tax purposes, you are considered a U.S. person if you are:

- An individual who is a U.S. citizen or U.S. resident alien,
- A partnership, corporation, company, or association created or organized in the United States or under the laws of the United States,
- An estate (other than a foreign estate), or
- A domestic trust (as defined in Regulations section 301.7701-7).

Special rules for partnerships. Partnerships that conduct a trade or business in the United States are generally required to pay a withholding tax under section 1446 on any foreign partners' share of effectively connected taxable income from such business.

Further, in certain cases where a Form W-9 has not been received, the rules under section 1446 require a partnership to presume that a partner is a foreign person, and pay the section 1446 withholding tax. Therefore, if you are a U.S. person that is a partner in a partnership conducting a trade or business in the United States, provide Form W-9 to the partnership to establish your U.S. status and avoid section 1446 withholding on your share of partnership income.