

INVITATION TO BID



CITY OF CALLAWAY CHERRY STREET DIRECTIONAL BORE REBID NO: PW2018-05

ADVERTISED: The Bay County News Herald, Tuesday, June 19, 2018

PREBID MEETING: N/A

BID DEADLINE: 10:00 a.m. Tuesday, July 3, 2018
& OPENING

BIDS/PROPOSALS ARE TO BE SUBMITTED TO:

**CITY OF CALLAWAY
ATTN: JANICE L. PETERS, CITY CLERK
6601 EAST HWY. 22
CALLAWAY, FL 32404**

ATTACHMENTS: Notice of Request for Bids/Proposals
General Instructions and Conditions
Special Instructions and Conditions
Minimum Technical Specifications
Agreement
Bid Forms (**To be submitted with bid.**):
Bid/Certification Form
Public Entity Crimes Statement
Drug Free Workplace Certification
Proprietary/Confidential Information Form

Janice L. Peters, MMC, City Clerk

INSTRUCTIONS TO BIDDERS/PROPOSERS

Qualified firms are invited to submit a Bid/Proposal to the **CITY OF CALLAWAY** for the **CHERRY STREET DIRECTIONAL BORE, REBID NO: PW2018-05**, by replying to the enclosed specification. In order for the Bid/Proposal to be considered, complete all items in this specification.

All Bids/Proposals must include one **(1) original** and **three (3) copies** and be addressed to:

CITY OF CALLAWAY
ATTN: CITY CLERK
6601 East Hwy. 22
CALLAWAY, FL 32404

Proposals must be **received** at the address listed above no later than **10:00 a.m. on Tuesday, July 3, 2018**. Late Proposals will not be accepted, regardless of the reason.

Proposal envelopes must be **sealed and marked** with the RFP number, due date, and name of Proposer so as to identify the enclosed submittal. If more than one package is submitted, please mark "1 of 2", "2 of 2", etc.

INTERPRETATION OF SPECIFICATION

All questions pertaining to the terms and conditions of the scope of work of this Bid/Proposal must be submitted **in writing** via email or fax to the City Clerk as shown below:

Janice L. Peters, MMC, City Clerk
City of Callaway
6601 East Hwy. 22
Callaway, FL 32404
jpeters@cityofCallaway.com
Fax: (850) 871-2444

No oral interpretations will be made to any firm as to the meaning of specifications or any other contract documents. In accordance with Florida Statutes 287.057(23), "Respondents to this solicitation or persons acting on their behalf may not contact, between the release of the solicitation and the end of the 72-hour period following the agency posting the notice of intended award, excluding Saturdays, Sundays, and state holidays, any employee or officer of the executive or legislative branch concerning any aspect of this solicitation, except in writing to the procurement officer or as provided in the solicitation documents. Violation of this provision may be grounds for rejecting a response." Questions must be submitted as referenced above.

All questions must be received at least five (5) calendar days prior to the scheduled opening of Bids/Proposals. Any interpretation of the Bid/Proposal terms, conditions, and/or specification, if made, will be only by Addendum issued by the City Clerk. A copy of such Addendum will be posted to the City's website at www.cityofcallaway.com and mailed to each proposer that received a copy of the advertisement of the Request for Bids/Proposals. **IT IS THE RESPONSIBILITY OF THE BIDDER/PROPOSER TO CHECK THE CITY'S WEBSITE FOR ANY ADDENDUMS PRIOR TO SUBMITTING A BID/PROPOSAL.** No verbal instructions or interpretations of drawings and specifications will be made other than indicated above.

The City reserves the right to reject any or all proposals, to waive informalities in the Bids/Proposals and to re-advertise for Bids/Proposals. The City also reserves the right to separately accept or reject any item or items of a Bid/Proposal and to award and/or negotiate a contract in the best interest of the City.

TABLE OF CONTENTS



CITY OF CALLAWAY CHERRY STREET DIRECTIONAL BORE REBID NO: PW2018-05

**Total Pages
Per Section**

SPECIAL INSTRUCTIONS AND CONDITIONS.....	2
GENERAL INSTRUCTIONS AND CONDITIONS	9
AGREEMENT FOR CONTRACTOR SERVICES	9
BID/PROPOSAL CHECKLIST	1
BID CERTIFICATION FORM	3
PUBLIC ENTITY CRIMES STATEMENT.....	2
DRUG-FREE WORKPLACE CERTIFICATION	1
PROPRIETARY/CONFIDENTIAL INFORMATION FORM	1
MINIMUM TECHNICAL SPECIFICATIONS.....	150
PLANS	4

CITY OF CALLAWAY
SPECIAL INSTRUCTIONS AND CONDITIONS
CHERRY STREET DIRECTIONAL BORE
REBID NO: PW2018-05

* Note: The GENERAL INSTRUCTIONS AND CONDITIONS (attached hereto) apply, except as set forth below, for this Bid.

A. **Description:** () See Attached (X) As Follows

The project will consist of the installation of approximately 260 LF of 6” directional bore under US 98/Tyndall parkway on the north side of Cherry Street, fittings, valves, flushing hydrant, concrete work, testing and closeout.

B. **Specifications:** (X) See Attached () As follows:

See attached Minimum Technical Specifications

C. **Contract/Agreement Required:** () None (X) As follows:

See attached Sample Contract

D. **Items to be submitted with Bid:** () None (X) As follows:

- Bid/Certification Form(s) with signature page(s).
- Public Entity Crimes Statement.
- State of Florida or County Contractor License/Certification Copy
- Drug Free Workplace Certification.
- One (1) original with three (3) copies of the bid submittal.
- List of Subcontractors, if applicable, and
- List of three (3) references for similar type work with contact information.
- Proprietary/Confidential Information Form

E. **Deadline and place for submission and opening of Bids:**

3:00 p.m., TUESDAY, JULY 3, 2018 (BID DEADLINE)
City Hall
6601 East Hwy. 22
Callaway, FL 32404

F. **Insurance Requirements:** () None (X) As follows:

	<u>Minimum Coverage</u>
<u>Property Damage:</u>	\$ 500,000
<u>General Liability:</u>	\$ 1,000,000/2,000,000
<u>Automobile Liability:</u>	\$ 1,000,000/2,000,000
<u>Workers' Compensation:</u>	\$ Statutory Limit*

Note: Insurance Certificate must be provided by Successful Bidder upon execution of Agreement. City is to be listed on the bidder's/proposer's Certificate of Insurance as additionally insured and certificate holder in order for the City to be notified if the insurance is canceled or modified.

H. Bond Requirements: () None (X) As follows:

	<u>Amount of Bond</u>
Bid Bond	\$ _____ or <u>5</u> % of Bid
Performance Bond	\$ _____ or <u>N/A</u> % of Bid
Payment Bond	\$ _____ or <u>N/A</u> % of Bid
Construction Bond	\$ _____ or <u>N/A</u> % of Bid
Other: _____	\$ _____ or <u>N/A</u> % of Bid

I. Number of Copies of Bid Forms with original signature(s) Required:

One (1) original, with notarized Signatures, plus three (3) copies

NOTICE:

Proposals may be rejected if all documents are not complete and executed, and the numbers of copies specified/requested of each are not submitted with the proposal.

GENERAL INSTRUCTIONS AND CONDITIONS

(1) NOTICE TO BIDDERS/PROPOSERS

The following general instructions and conditions apply to all Requests for Bids/Proposals unless modified by the provisions set forth in the “**Special Instructions and Conditions**” attached hereto. If there is a conflict between the “Special Instructions and Conditions” and these “General Instructions and Conditions,” the provisions in the Special Instructions and Conditions will apply. **Note: the General Instructions and Conditions and the Special Instructions and Conditions are periodically revised; potential Bidders/Proposers should read both carefully prior to submitting a Bid/Proposal. The attached Special Instructions and Conditions apply only to this Bid/Proposal.**

(2) SUBMITTAL OF BIDS/PROPOSALS

Qualified businesses or individuals requesting consideration must submit a complete Bid/Proposal with any/all attachments in a sealed package clearly marked with the **name and number of the Bid/Proposal**, to the attention of the City Clerk, prior to closing time at the address shown in the **Special Instructions and Conditions** attached hereto. If not so marked as to this wording, sealed and/or received by the closing time, the Bid/Proposal will not be accepted. Bid/Proposal packages, additional information regarding this Bid/Proposal, or the bidding procedures may be obtained by contacting the City Clerk, 6601 East Hwy. 22, Callaway, FL 32404, (850) 215-6694.

It shall be the sole responsibility of the Bidders/Proposers to have their Bid/Proposal delivered on or before the closing time and date stated in the **Special Instructions and Conditions**. Any Bids/Proposals received after the stated time and/or due to delays caused by mail or courier delivery, or any other reason, shall not be opened or otherwise considered, and will be returned at the bidder's/proposer's expense.

Bids/Proposals shall be opened and publicly announced at the City Clerk's Office, City Hall, 6601 East Hwy. 22, Callaway, Florida, after closing of Bids/Proposals, unless otherwise specified in the Special Instructions and Conditions.

(3) SPECIFICATIONS AND REQUIREMENTS

The detailed specifications and additional requirements relating to this Bid/Proposal are set forth in the Special Instructions and Conditions attached hereto.

SILENCE OF SPECIFICATIONS: The apparent silence of any specification as to any details or any omission of a detailed description concerning any point shall be regarded as meaning that only the best construction practices are to prevail and that only new materials of first quality and correct type, size and design are to be used. All workmanship is to be first quality. All interpretations of specifications shall be made accordingly by the City.

(4) BID/PROPOSAL FORM

Bidders/Proposers shall complete, sign and furnish the “Bid Certification Form”, together with the forms, specifications and materials required in the “Special Instructions and Conditions” or any exhibits attached hereto. This will include a properly executed Drug-Free Workplace Certification, and a Sworn Statement on Public Entity Crimes Form, pursuant to Section 287.133(3)(a), Florida Statutes. The minimum number of complete Bid/Proposal packages to be submitted is set forth in the Special Instructions and Conditions.

If the "Special Instructions and Conditions" include a "Scope of Work" provision, and/or provide for a supplemental and or implementing agreement, the City reserves the right to modify the "Scope of Services." Further, the terms and conditions of any such agreement shall be modified prior to execution by the City, if such modifications are determined to be in the best interest of the City.

Bids/Proposals may be considered non-responsive, at the sole option of the City, and may be rejected if they include omissions, alterations of form, additions not called for, conditions or limitations, unauthorized alternate Bids/Proposals, submission of less than the number of bid packages requested, or other irregularities of any kind.

Unless otherwise stated, the price(s) set forth in the Bid/Proposal include(s) all costs and expenses for labor, equipment, materials, commissions, transportation charges and expenses, handling material inspection, and patent fees and royalties, together with any and all other costs and expenses for providing the service, equipment, materials or performing and completing the work as shown according to the plans and specifications herein.

If quotations are requested for the various items of work, they are intended to establish a total price for providing the materials, equipment, services, or completing the work in its entirety. If the Bidder/Proposer determines that the cost for any item of work has not been established by the Proposal Form, the cost for that work is to be included in other applicable Bid/Proposal item(s), so that the Bid/Proposal reflects the total price for completing that work in its entirety.

In the event of a discrepancy between a unit bid price and an extension, the unit bid price will govern. Written prices shall govern over figures.

(5) CLARIFICATION AND ADDENDA

Each Bidder/Proposer shall examine all Bid/Proposal documents and shall judge all matters relating to the adequacy and accuracy of such documents. Any inquiries, suggestions or requests concerning the interpretation, clarification or additional information pertaining to this Invitation to Bid/Request for Bid/Proposal will be accepted by the City Clerk up to and including five (5) working days prior to the closing date and time stated herein. The issuance of a written addendum signed by the City Clerk is the only official method whereby interpretation, clarification or additional information can be given. The City shall not be responsible for oral interpretations given by any City employee, representative or others. If any addenda are issued, the City will attempt to notify all known prospective Bidders/Proposers. However, it shall be the responsibility of each Bidder/Proposer, prior to submitting a Bid/Proposal, to contact the City Clerk's Office to determine if addenda were issued, and to make such addenda a part of the Bid/Proposal. If an addendum has been issued, and was not incorporated in the Bid/Proposal documents submitted by Bidder/Proposer, the Bid/Proposal may not be accepted or considered by the City.

(6) MANUFACTURER'S NAMES AND APPROVED EQUIVALENTS

Unless otherwise specifically stated in the Special Instructions and Conditions, any manufacturer's names, trade names, brand names, catalog numbers, or similar information listed in a specification, are for the purpose of information and illustration, and are not intended to restrict the submission of alternates meeting minimum specifications. The Bidder/Proposer may offer the same or any alternate for which the Bidder/Proposer is an authorized representative, which meets or exceeds the specifications for any item. If a manufacturer's name or model is included in the specification, and a Bid/Proposal is based on alternate products or services which Bidder/Proposer maintains is equivalent and meets or exceeds specifications, Bidder/Proposer is to indicate on the Bid/Proposal Form the manufacturer's name and related information of the alternate; including any

deviation from the specifications. Unless expressly noted on the Bid/Proposal that an alternate is being proposed, and the specification includes a specific manufacturer's model or brand, the Bid/Proposal will be considered as a quotation for the item(s) stated in the specifications.

(7) INFORMATION AND DESCRIPTIVE LITERATURE

Bidders/Proposers must furnish all information requested in the Bid/Proposal packet including but not limited to any sketches, plans, designs, specification, and descriptive literature regarding the product(s)/service(s) being offered. Bids/Proposals which do not comply with these requirements are subject to rejection. Reference to submission of documentation or materials with a previous Bid/Proposal will not satisfy this provision.

(8) BONDS/INSURANCE

If the Bid/Proposal is accepted by the City, it will become a binding contract on both parties. If a bond or cashiers/certified check is required as a bond, it shall be submitted with the Bid/Proposal. If the undersigned shall fail to deliver or perform, or if applicable, execute a contract if provided for herein, then the City may, at its option, determine that the undersigned has abandoned the award/contract, and thereupon such acceptance of the Bid/Proposal and/or award shall be null and void, and any cashiers/certified check or bond accompanying this Bid/Proposal shall be forfeited to and become the property of the City. The full amount of said check, or if a bond, the full amount of such bond, shall be paid to the City as partial liquidated damages; otherwise, any bond or cashiers/certified check accompanying this Bid/Proposal shall be returned to the undersigned within 30 calendar days from the date of award, or if provisions for a Notice to Proceed are included, from the date of the Notice to Proceed.

If a bid or proposal bond is required, the bonds of unsuccessful Bidders/Proposers will be returned within 30 calendar days of the Bid/Proposal due date, except as set forth below.

If a proposal is subject to the Competitive Negotiations Act, the bonds will be returned within 60 days of the proposal due date, except for the bond of the 3 highest ranked proposers. Within 30 days of execution of a contract, bonds from the remaining unsuccessful proposers will be returned.

Bid bond, if required, will be returned within 30 calendar days of delivery/acceptance of the item(s) bid or service(s) provided, unless a standard payment and performance bond is required. When a standard Payment and Performance Bond is required, the bid bond of the successful Bidder/Proposer will be returned within 30 calendar days from the date of the Notice to Proceed.

In the event a bid is awarded, a proposal is accepted, and/or a contract is executed, and the Bidder/Proposer chooses not to proceed, or fails to perform for any reason, the bond will be forfeited and retained by the City as partial liquidated damages. Future Bids/Proposals will not be accepted for consideration from the Bidder/Proposer for five (5) years, or such shorter period as the City Commission may determine.

In the event an award/selection is not made within 90 days after the Bid/Proposal due date and the City does not return all bonds, upon 30 business days written request, a bidders/proposer may withdraw their bid or proposal from consideration, and obtain a refund of the Bid/Proposal bond.

All Awards will be subject to presentation of any required performance bond or certificate of insurance prior to any purchase authorizations, agreements, contract documents, or delivery. The Bidder/Proposer shall maintain any performance bonds or insurance coverage set forth in the Special Instructions and Conditions, at its own expense. If insurance is required, the City is to be listed on the bidder/proposer's Certificate of Insurance as an additional insured and certificate holder in order that the City will be notified if the insurance is canceled or

modified. The certificate shall also list the name of the project/service/equipment purchased, and the expiration date of the policy. At the City's option, an award may be canceled and any bid bond forfeited if any required performance bond or insurance certificate is not delivered within 21 calendar days of the date of award.

***Note:** The provisions of this section are in addition to and not a replacement for, any Bid/Proposal and/or performance bond required in the Special Instructions and Conditions. The foregoing provisions are intended to be in addition to any other legal remedy available to the City for non-performance by a Bidder/Proposer subsequent to the acceptance and/or award of a bid or proposal.*

(9) SERVICE AND WARRANTY

If any warranty repair or replacement service is requested in the Special Instructions and Conditions, any deviation or limitation from the requirements is to be expressly stated on the Bid Request for Proposal Certification Form.

If the service or product provided to the City pursuant to the bid consists of computer hardware, software or firmware, the Bidder/Proposer warrants that said product will accurately process/or reflect data from, into and between the twentieth and twenty-first centuries, including leap-year calculations.

(10) CONTRACT FORMS

Any agreement or contract resulting from the acceptance of a Bid/Proposal shall be on forms either supplied by or approved by the City, and shall contain, as a minimum, applicable provisions of the Invitation to Bid/Request for Proposal, and the Bid/Proposal documents to be submitted by Bidder/Proposer, including the Special Instructions and Conditions, General Instructions and Conditions, and all attachments therewith. The City reserves the right to reject any Bid/Proposal or resulting agreement which does not conform to the Invitation to Bid/Proposal and, if applicable, any City requirement relating to such an Agreement.

The City reserves the right to extend any contract or agreement for an additional period of not more than ninety (90) days beyond the original expiration date. Prices in effect on the last day of the contract shall remain in effect for the contract extension period. Additional extensions shall be subject to agreement of both parties.

The successful Bidder/Proposer will be required to execute any resulting agreement and provide any bonds or insurance certificates required within 10 days of contract execution. Failure to timely execute the necessary bond or insurance certificate will result in cancellation of an award, with no further obligation by the City.

This Bid/Proposal is subject to the appropriation of funds in an amount sufficient to allow continuation of the City's performance in accordance with the terms and conditions of this Bid/Proposal for each and every fiscal year in which this Bid/Proposal is executed and entered into. If funds are not appropriated/available, the City shall provide prompt written notice to the selected Bidder/Proposer that effective thirty (30) days after giving such notice, or upon the expiration of the time for which funds were appropriated, whichever occurs first, the City will thereafter be released of all further obligations related to the Bid/Proposal and/or award.

(11) BID/PROPOSAL EXPENSES

All expenses for preparing and submitting Bids/Proposals to the City are to be borne by the Bidder/Proposer.

(12) VARIANCES

Any variance whatsoever from the Bid/Proposal Specifications are to be clearly identified on the Bid/Proposal form. Acceptance of any proposed variations will be at the sole discretion of the City.

(13) CONFLICT OF INTEREST

The award of a bid or acceptance of proposal is subject to Chapter 112, Florida Statutes. All Bidders/Proposers must disclose with their Bid/Proposal the name of any officer, director, or agent who is a city official or employee, or a member of an official's or employee's immediate family. Further, Bidders/Proposers must disclose the name of any city official or employee, or a member of an official's or employee's immediate family, who owns directly or indirectly an interest of ten percent (10%) or more in the bidder's/proposer's firm or related business.

(14) DELIVERY

All items provided pursuant to an award are to be delivered prepaid to the City Clerk's Office, 6601 East Hwy. 22, Callaway, Florida 32404-2041, unless a different location is specified in the Special Instructions and Conditions. All delivery charges are to be included in the Bid/Proposal price. No Collect on Delivery (C.O.D.) will be accepted. Title and risk of loss or damage to all items shall be the responsibility of the Bidder/Proposer until delivered to the City.

(15) INSPECTION, ACCEPTANCE AND TITLE

All items delivered pursuant to an award are subject to inspection and review prior to acceptance by the City. Acceptance, evidenced by separately written Notice of Acceptance or full payment, will be made only after verification of compliance with all specifications. Acknowledgment of delivery and/or partial payment does not constitute acceptance.

(16) OWNERSHIP RIGHTS AND PUBLIC RECORDS LAW

Public Records Law. Bidder/Proposer acknowledges that they are familiar with the provisions of the Public Records Law of the State of Florida.

Bidder/Proposer agrees to comply with Chapter 119, Florida Statutes, and specifically per Florida Statute 119.0701, Bidder/Proposer agrees to keep and maintain public records that would be required by the City of Callaway in order to perform the services provided for in this agreement; Bidder/Proposer agrees to provide public access to any required public records in the same manner as a public agency; Bidder/Proposer agrees to protect exempt or confidential records from disclosure; Bidder/Proposer agrees to meet public records retention requirement; and Bidder/Proposer agrees that at the end of the term of this agreement, to transfer all public records to the City of Callaway and destroy any duplicate, exempt or confidential public records.

All products generated by the Bidder/Proposer for the City become the property of the City. The City may require submission of any electronic file version of reports, data, maps, or other submission of documentation produced for or as a result of this Bid/Proposal in addition to paper documents.

Further, in accordance with the Public Records Laws of the State of Florida, Section 119.0701, (2013), Contractor must:

- A. Keep and maintain public records that ordinarily and necessarily would be required by the public agency in order to perform the service.
- B. Provide the public with access to public records on the same terms and conditions that the public agency would provide the records and at a cost that does not exceed the cost provided in this chapter or as otherwise provided by law.
- C. Ensure that public records that are exempt or confidential and exempt from public records are not disclosed except as authorized by law.
- D. Meet all requirements for retaining public records and transfer, at no cost, to the public agency all public records in possession of the contractor upon termination of the contract and destroy any duplicate public records that are exempt or confidential and exempt from public record disclosure requirements. All records stored electronically must be provided to the public agency in a format that is compatible with the information technology systems of the public agency.
- E. If a contractor does not comply with a public records request, the public agency shall enforce the contract provision in accordance with the contract.

(17) RESERVED RIGHTS

The City reserves the right to reject any and all Bids/Proposals, with or without statement of cause, request resubmissions, or to waive any irregularities or technicality or negotiate modifications to any Bid/Proposal which may be in the best interest of the City.

Bidders/Proposers which do not normally engage in providing the types of commodities/services specified herein may be required to demonstrate they have sufficient financial support, equipment, and organization to ensure they can satisfactorily perform if awarded a bid/contract under the terms and conditions herein stated.

The City reserves the right to make such investigations as it deems necessary to determine the ability of any Bidder/Proposer to perform the work or service requested. Any information the City deems necessary to make such determinations shall be provided by the Bidder/Proposer upon request as a condition of further consideration of the Bid/Proposal. The applicability of all information obtained and the City's decision shall be final. By submitting a bid or proposal, Bidder/Proposer authorizes such investigation.

If the contract awarded as a result of this bid is terminated prior to the end of the term, the City reserves the right to award the balance of the contract to the next lowest responsive and responsible bidder.

(18) ADVERTISING

In submitting a Bid/Proposal, Bidder/Proposer agrees not to use the results therefrom as a part of any commercial advertising or marketing purposes without written approval of the City Manager.

(19) GOVERNMENTAL RESTRICTIONS/REQUIREMENTS

In the event any governmental restrictions are imposed which would necessitate alteration of the material, quality, workmanship, or performance of the items offered in a Bid/Proposal, it shall be the responsibility of the successful Bidder/Proposer to immediately notify the City of the specific regulation which required an

alteration, and the specific alterations that will be made to the item(s) bid/proposed. The City reserves the right to accept any such alteration/substitution, including any price adjustments resulting therefrom, or to cancel the award at no expense to the City.

(20) NON-DISCRIMINATION

There shall be no discrimination as to race, sex, color, creed, handicap, or national origin in the selection, award, or operations conducted, or performance related to any bid or proposal.

(21) UNAUTHORIZED EMPLOYEES OR AGENTS

Employment of unauthorized aliens by Bidder/Proposer is considered a violation of Section 274A(e) of the Immigration and Nationality Act. If selected Bidder/Proposer knowingly employs unauthorized aliens, such action shall be cause for unilateral cancellation of this agreement and the City may recover damages from selected Bidder/Proposer resulting from such cancellation. The selected Bidder/Proposer shall be responsible for including this provision in any context with, and requiring compliance by any/all subcontracts performing for selected Bidder/Proposer relating to this agreement.

(22) OTHER GOVERNMENTAL ENTITIES - OPTIONAL APPLICATION

In the State of Florida, other Florida public entities may “piggy-back” on competitive Bid/Proposal awards under the same terms and conditions, if all parties are in agreement.

(23) LEGAL NAME

Bids/Proposals shall clearly indicate the legal name and organizational structure, business address, telephone number, and email address of the Bidder/Proposer. Bids/Proposals shall be signed above the typed or printed name and title of the individual submitting the Bid/Proposal. The signer shall warrant he/she has the authority to bind the Bidder/Proposer to the terms and conditions of the submitted Bid/Proposal.

(24) WAGES

State and Federal minimum wage and hour regulation apply to Bidder/Proposer and all subcontractors.

(25) SELECTION

The City intends to award this bid to the lowest responsive and responsible bidder or bidders. However, the City reserves the right to reject any and all Bids/Proposals. The procedures for the selection/award of Bids/Proposals are provided for by Florida Statutes and the City’s Charter, Code of Ordinances, and Administrative Policies. Generally, all Bids/Proposals are reviewed by City staff and evaluated by the City Manager, and if required by law, by a Selection Advisory Committee appointed by the City Manager. The type and price of the product(s) or service(s) being acquired determines if an award or selection may be made by the City Manager or requires City Commission approval. For information on which procedure applies to a particular Bid/Proposal contact the City Clerk.

Bids/Proposals will be evaluated based on, but not limited to, one or more of the following criteria as appropriate:

- compliance with specifications,
- price (if applicable),

- capability/adequacy of Bidder/Proposer,
- past and current projects, services or equipment provided to the City,
- delivery schedule,
- prior government projects, services or equipment provided to other jurisdictions, and
- general reputation, location and references.

Separate procedures and requirements relating to Requests for Bids/Proposals/Qualifications apply for certain grant programs and for professional services, for example the Consultants' Competitive Negotiation Act (Florida Statute 287.055), and by the City's Code. When the City initiates such a Request for Proposals/Qualifications, the selection process and related procedures are included in the Special Instructions and Conditions.

Pursuant to Chapter 287.087 Florida Statutes, in the event two (2) or more bids are equal with respect to price, quantity, and services, preference will be given to Bidders/Proposers which have implemented Drug-Free Workplace Programs.

Further, per 287.087(11) "If two equal responses to a solicitation or a request for quote are received and one response is from a certified minority business enterprise, the agency shall enter into a contract with the certified minority business enterprise." In addition, at the sole discretion of the City, payment terms, conditions, and other consequential information may be utilized in resolving apparent tie Bids/Proposals.

NOTE: For consideration, Bidder/Proposer must return the Bid Certification Form included in the Bid/Proposal package.

(26) INDEMNIFY

After notification of award, the successful Bidder/Proposer agrees to defend, indemnify and hold harmless the City and its officials, officers, employees, agents, and invites, from and against all claims, suits, sections, damages, or causes of action arising from any personal injury, loss of life or damage to property, sustained by reason of, or as a result of constructing, manufacturing, processing, delivery, or performance of the services or work for which the Bid/Proposal was awarded or any resulting agreement executed, and from and against any orders, judgments, or decrees which may be entered thereto, and from and against all costs, attorney's fees, expenses, and liabilities incurred in or by reason of the defense of any such claim, suit or action, and the investigation thereof. Nothing in any resulting agreement shall be deemed to affect the rights, privileges and immunities of the City of Callaway.

The selected Bidder/Proposer, without exception, shall also indemnify and hold harmless the City and its officials, employees, agents, and invites from liability of any nature or kind, including cost and expenses for or on account of any copyrighted, patented or unpatented invention, process or article manufactured or used in the performance of the contract, including its use by the City. If the selected Bidder/Proposer uses any design, device or materials covered by patent or copyright, it is mutually agreed and understood that the Bid/Proposal prices include all royalties or costs arising from the use in any way of such design, device or materials involved in the product and/or services provided to the City.

(27) MODIFICATION - AFTER AWARD

Any changes proposed by a Bidder/Proposer after an award in (a) materials used, (b) manufacturing process, (c) construction or (d) specifications, are to be submitted in writing to the City Manager prior to delivery. No changes shall be approved and binding upon the City unless evidenced by a Change Order issued and signed by the City Manager.

(28) ASSIGNMENT

Any purchase order issued pursuant to this bid invitation/request for proposal and the funds which may become due hereunder, are not assignable, except with the prior written approval of the City Manager.

(29) DISCLOSURE

Bidder/Proposer acknowledges by submitting a Bid/Proposal that all information provided to the City is part of the public domain as defined by Florida Statutes and is considered a public record. Information should not be labeled "confidential," unless specifically exempted under said Statutes, and exempts the City from any liability for releasing all information to the public, including inadvertently releasing information deemed confidential by the Bidder/Proposer.

(30) TAXES

The City is a tax-exempt Florida municipality, Federal Employment Identification Number 59-6000-284, Florida State Tax Number 37-02-008131-54C. Copies of Exemption Certificate and related information may be obtained by contacting the City Clerk, City of Callaway, 6601 East Hwy. 22, Callaway, Florida 32404-2041 or (850) 215-6694.

(31) APPLICABLE LAWS/LEGAL VENUE

All applicable laws, regulations and ordinances of the State of Florida, Bay County and the City of Callaway will apply to consideration and award of any Bid/Proposal and the performance of the Bidder/Proposer pursuant thereto, and shall be governed by the laws of the State of Florida both as to intention and performance. The venue for any action arising from the award or subsequent performance shall lie exclusively in the Circuit Court of Bay County, Florida, or the United States District Court for the Northern District of Florida, as applicable.

NOTE: ANY AND ALL PROVISIONS SET FORTH IN THE SPECIAL INSTRUCTIONS AND CONDITIONS ATTACHED HERETO, WHICH VARY FROM THESE GENERAL INSTRUCTIONS AND CONDITIONS, SHALL HAVE PRECEDENCE.

**AGREEMENT FOR CONTRACTOR SERVICES
CHERRY STREET DIRECTIONAL BORE
REBID NO: PW2018-05**

This Agreement made as of this ____ day of, _____, 2018, by and between the **City of Callaway**, Florida - (the "CITY"), and _____ authorized to do business in the State of Florida (the "CONTRACTOR"), and whose address is _____, Phone: _____ Fax: _____.

In consideration of the mutual promises contained herein, the CITY and the CONTRACTOR agree as follows:

ARTICLE 1 - SERVICES

The CONTRACTOR'S responsibility under this Agreement is to furnish, deliver, and construct all materials, labor, and equipment and to perform all operations in accordance with the plans and specifications and as listed in the Bid Form for the **CHERRY STREET DIRECTIONAL BORE REBID NO: PW2018-05**.

Services of the CONTRACTOR shall be under the general direction of the CITY MANAGER, who may designate a person to act as the CITY'S representative (hereinafter "REPRESENTATIVE") during the performance of this Agreement.

The CITY shall furnish to the CONTRACTOR up to four (4) sets of the Contract Documents for execution of the Work. Additional copies of the Contract Documents are available at the cost of reproduction.

ARTICLE 2 – SCHEDULE

The CONTRACTOR will commence the work required by the CONTRACT DOCUMENTS within 10 calendar days after the date of the NOTICE TO PROCEED and will substantially complete the project within 60 consecutive calendar days, unless the period for completion is extended otherwise by the CONTRACT DOCUMENTS.

ARTICLE 3 - PAYMENTS TO CONTRACTOR

- A. The CITY shall pay to the CONTRACTOR for services satisfactorily performed \$_____, which includes all direct charges, indirect charges and reimbursable expenses, if any. The CONTRACTOR will bill the CITY monthly.
- B. The invoices received from the CONTRACTOR pursuant to this Agreement will be reviewed and approved by the City Manager's office, indicating that services have been rendered in conformity with the Agreement, and then will be sent to the Finance Department for payment. The invoice must specify the work performed. Ten percent (10%) of each invoiced amount will be withheld and retained by the CITY until completion of the work to the satisfaction of the CITY.
- C. In order for both parties herein to close their books and records, the CONTRACTOR will clearly state "final invoice" on the CONTRACTOR'S final/last billing to the CITY. This indicates that all services have been performed and all charges and costs have been invoiced to the CITY. Since this account will thereupon be closed, any and other further charges if not properly included on this final invoice shall be waived by the CONTRACTOR.

- D. CONTRACTOR acknowledges that it has reviewed the scope of work and inspected the work site and does not anticipate having any CONTRACTOR requested change orders.

ARTICLE 4 - TERMINATION

This Agreement may be terminated by the CONTRACTOR on 60 days prior written notice to the CITY in the event of substantial failure by the CITY to perform in accordance with the terms hereof through no fault of the CONTRACTOR. It may also be terminated by the CITY, with or without cause, immediately upon written notice to the CONTRACTOR. Unless the CONTRACTOR is in breach of this Agreement, the CONTRACTOR shall be paid for services rendered to the CITY'S satisfaction through the date of termination. After receipt of a termination notice and except as otherwise directed by the CITY the CONTRACTOR shall:

- A. Stop work on the date and to the extent specified.
- B. Terminate and settle all orders and subcontracts relating to the performance of the terminated work.
- C. Transfer all work in process, completed work, and other material related to the terminated work to the CITY.
- D. Continue and complete all parts of the work that have not been terminated.

ARTICLE 5 - PERSONNEL

The CONTRACTOR represents that it has or will secure at its own expense all necessary personnel required to perform the services under this Agreement. Such personnel shall not be employees of or have any contractual relationship with the CITY.

All of the services required herein under shall be performed by the CONTRACTOR or under its supervision, and all personnel engaged in performing the services shall be fully qualified and, if required, authorized or permitted under State and local law to perform such services.

The CONTRACTOR warrants that all services shall be performed by skilled and competent personnel to the highest professional standards in the field.

ARTICLE 6 - SUBCONTRACTING

The CITY reserves the right to accept the use of a subcontractor or to reject the selection of a particular subcontractor and to inspect all facilities of any subcontractors in order to make a determination as to the capability of the subcontractor to perform properly under this Agreement. The CONTRACTOR is encouraged to seek minority and women business enterprises for participation in subcontracting opportunities.

If a subcontractor fails to perform or make progress, as required by this Agreement, and it is necessary to replace the subcontractor to complete the work in a timely fashion, the CONTRACTOR shall promptly do so, subject to acceptance of the new subcontractor by the CITY.

ARTICLE 7 - FEDERAL AND STATE TAX

The CONTRACTOR shall be responsible for payment of its own FICA and Social Security benefits with respect to this Agreement and the personnel it employs.

ARTICLE 8 – INSURANCE & BONDS

- A. The CONTRACTOR shall not commence work under this Agreement until it has obtained all insurance and bonds required under this paragraph and such insurance has been verified by the CITY.
- B. All insurance policies shall be issued by companies authorized to do business under the laws of the State of Florida.

The CONTRACTOR shall maintain, during the life of this Agreement, comprehensive automobile liability insurance in the amount of \$1,000,000 and \$2,000,000 combined single limit for property damage and bodily injury liability covering claims which may arise from the ownership, use, or maintenance of owned and non-owned automobiles, including rented automobiles, whether such operations be by the CONTRACTOR or by anyone directly or indirectly employed by the CONTRACTOR. CONTRACTOR shall purchase and maintain a policy or policies of commercial general liability insurance satisfactory in all respects to CITY, and casualty and extended coverage insurance. All policies shall be occurrence form policies and shall name CITY as an additional insured, with the premium thereon fully paid by CONTRACTOR on or before their due date. The general liability insurance policy shall afford minimum protection of \$1,000,000 and \$2,000,000 combined single limit coverage for bodily injury.

Required insurance shall be documented in Certificates of Insurance which provide that CITY shall be notified at least 30 days in advance of cancellation, non-renewal or adverse change. New Certificates of Insurance are to be provided to CITY at least 15 days prior to coverage renewals. City of Callaway, Florida is to be named as an additional insured entity.

If requested by CITY, CONTRACTOR shall furnish complete copies of its insurance policies, forms and endorsements.

For commercial general liability coverage, CONTRACTOR shall, at the option of CITY, provide an indication of the amount of claims, payments or reserves chargeable to the aggregate amount of liability coverage.

Receipt of certificates or other documentation of insurance or policies or copies of policies by CITY, or by any of its representatives, which indicate less coverage than required does not constitute a waiver of CONTRACTOR'S obligation to fulfill the insurance requirements herein.

CONTRACTOR shall also purchase and maintain workers compensation insurance for all obligations imposed by law, with employer's liability limits of at least the statutory limit, or provide notarized affidavit of exemption listing relevant statutes. CONTRACTOR shall also purchase any other coverage required by law.

CONTRACTOR'S maintenance of the insurance policies required hereunder shall not limit or otherwise affect its liability hereunder.

- C. In the event that a performance or payment bond is required due to use of grant funds for the project, by City Commission or as otherwise required, the CONTRACTOR shall not commence work under this Agreement until it has obtained the required bonds and provided such bonds to the CITY.

ARTICLE 9 - EXCUSABLE DELAYS

The CONTRACTOR shall not be considered in default by reason of any failure in performance if such failure arises out of causes reasonably beyond the CONTRACTOR'S control and without its fault or negligence. Such causes may include, but are not limited to: acts of God; the City's omissive and commissive failures; natural or public health emergencies; labor disputes; freight embargoes; and severe weather conditions. If failure to perform is caused by the failure of the CONTRACTOR'S subcontractor(s) and is without the fault or negligence of them, the CONTRACTOR shall not be deemed to be in default.

Upon the CONTRACTOR'S request, the CITY shall consider the facts and extent of any failure to perform the work and, if the CONTRACTOR'S failure to perform was without its fault or negligence as determined by the CITY, any affected provision of this Agreement shall be revised accordingly; subject to the CITY's rights to change, terminate, or stop any or all of the work at anytime.

ARTICLE 10 - LIQUIDATED DAMAGES

Liquidated damages shall be paid to the CITY at the rate of \$200 per day for all work awarded under the contract until the work has been satisfactorily completed as provided by the Contract Documents. Sundays and Legal Holidays shall be excluded in determining days in default.

It is agreed that the amount is the per-diem rate for damage incurred by reason of failure to complete the work. The said amount is hereby agreed upon as the reasonable costs which may be accrued by the CITY after the expiration of the time of completion. It is expressly understood and agreed that this amount is not to be considered in the nature of a penalty, but as liquidated damages which have accrued against the CONTRACTOR. The CITY shall have the right to deduct such damages from any amount due, or that may become due the CONTRACTOR, or the amount of such damages shall be due and collectable from the CONTRACTOR or Surety.

ARTICLE 11 - ARREARS

The CONTRACTOR shall not pledge the CITY'S credit or make it a guarantor of payment or surety for any contract, debt, obligation, judgment, lien, or any form of indebtedness.

ARTICLE 12 - DISCLOSURE AND OWNERSHIP OF DOCUMENTS

The CONTRACTOR shall deliver to the CITY for approval and acceptance, and before being eligible for final payment of any amount due, all documents and materials prepared by and for the CITY under this Agreement.

All written and oral information not in the public domain or not previously known, and all information and data obtained, developed, or supplied by the CITY or at its expense will be kept confidential by the CONTRACTOR and will not be disclosed to any other party, directly or indirectly, without the CITY'S prior written consent.

Such information and data shall be and will remain the CITY'S property and may be reproduced and reused at the discretion of the CITY.

All products generated by the CONTRACTOR for the CITY become the property of the CITY. The CITY may require submission of any electronic file version of reports, data, maps, or other submission of documentation produced for or as a result of this project in addition to paper documents.

The CITY and the CONTRACTOR shall comply with the provisions of the Florida Public Records Law.

PUBLIC RECORDS LAW. CONTRACTOR acknowledges that it is familiar with the provisions of the Public Records Law of the State of Florida.

CONTRACTOR agrees to comply with Chapter 119, Florida Statutes, and specifically per Florida Statute 119.0701, CONTRACTOR agrees to keep and maintain public records that would be required by the City of Callaway in order to perform the services provided for in this Agreement; CONTRACTOR agrees to provide public access to any required public records in the same manner as a public agency; CONTRACTOR agrees to protect exempt or confidential records from disclosure; CONTRACTOR agrees to meet public records retention requirement; and CONTRACTOR agrees that at the end of term of this Agreement, to transfer all public records to the City of Callaway and destroy any duplicate exempt or confidential public records.

All products generated by the CONTRACTOR for the CITY become the property of the CITY. The CITY may require submission of any electronic file version of reports, data, maps or other submission of documentation produced for or as a result of this Bid/Proposal in addition to paper documents.

Further, in accordance with the Public Records Laws of the State of Florida, Section 119.0701, (2013), Contractor must:

- A. Keep and maintain public records that ordinarily and necessarily would be required by the public agency in order to perform the service.
- B. Provide the public with access to public records on the same terms and conditions that the public agency would provide the records and at a cost that does not exceed the cost provided in this chapter or as otherwise provided by law.
- C. Ensure that public records that are exempt or confidential and exempt from public records are not disclosed except as authorized by law.
- D. Meet all requirements for retaining public records and transfer, at no cost, to the public agency all public records in possession of the contractor upon termination of the contract and destroy any duplicate public records that are exempt or confidential and exempt from public record disclosure requirements. All records stored electronically must be provided to the public agency in a format that is compatible with the information technology systems of the public agency.
- E. If a contractor does not comply with a public records request, the public agency shall enforce the contract provision in accordance with the contract.

All covenants, agreements, representations, and warranties made herein, or otherwise made in writing by any party pursuant hereto shall survive the execution and delivery of this Agreement and the consummation of the transactions contemplated hereby.

If the CONTRACTOR has questions regarding the application of Chapter 119, Florida Statutes, to the CONTRACTOR'S duty to provide public records relating to this contract, contact the custodian of public records, Janice Peters, City Clerk, at 850-215-6694, by email at jpeters@cityofcallaway.com, or via mail, at 6601 E. Hwy. 22, Callaway, FL 32404.

ARTICLE 13 - INDEPENDENT CONTRACTOR RELATIONSHIP

The CONTRACTOR is, and shall be, in the performance of all work services and activities under this Agreement, an independent contractor, and not an employee, agent, or servant of the CITY. All persons engaged in any of the work or services performed pursuant to this Agreement shall at all times, and in all places, be subject to the CONTRACTOR'S sole direction, supervision, and control. The CONTRACTOR shall exercise control over the means and manner in which it and its employees perform the work, and in all respects the CONTRACTOR'S relationship and the relationship of its employees to the CITY shall be that of an independent contractor and not as employees or agents of the CITY.

The CONTRACTOR does not have the power or authority to bind the CITY in any promise, agreement or representation.

The CONTRACTOR shall hold the CITY, its officers, agents and employees harmless and free from any loss, damage or expense arising out of any occurrence relating to this Agreement or its performance and shall indemnify the CITY, its officers, agents and employees, customers, and successors against any damage or claim of any type arising from the negligent or intentional acts or omission of the CONTRACTOR.

ARTICLE 14 - CONTRACT ASSIGNMENT

The CONTRACTOR shall not sublet, sell, transfer, assign or otherwise dispose of the CONTRACT or any portion thereof, or of his right, title, or interest therein, without written consent of the CITY. The CONTRACTOR shall complete the work contemplated by the terms and conditions of this Agreement in an amount equivalent to at least 50 percent (50%) of the dollar value of work to be performed under this Contract utilizing its own business or corporate entity, so that no single labor, material man, or subcontractor shall be permitted to perform more than 50% of the work contemplated by this Contract.

ARTICLE 15 - AMENDMENT

None of the provisions, terms and conditions contained in this Agreement may be added to, modified, superseded or otherwise altered, except by a written instrument executed by the parties hereto.

ARTICLE 16 - ENFORCEMENT COSTS

If any legal action or other proceeding is brought for the enforcement of this Agreement, or because of an alleged dispute, breach, default, or misrepresentation in connection with any provision, the successful or prevailing party or parties shall be entitled to recover reasonable attorney's fees, court costs and all expenses even if not taxable as court costs (including, without limitation, all such fees, costs and expenses incident to appeals), incurred in that action or proceeding, in addition to any other relief to which such party or parties may be entitled.

ARTICLE 17 - AUTHORITY TO PRACTICE

The CONTRACTOR hereby represents and warrants that it has and will continue to maintain all licenses and approvals required to conduct its business, and that it will at all times conduct its business activities in a reputable manner.

ARTICLE 18 - SEVERABILITY

If any term or provision on this Agreement, or the application thereof to any person or circumstances shall, to any extent, be held invalid or unenforceable, the remainder of this Agreement, or the application of such

terms or provisions to persons or circumstances other than those as to which it is held invalid or unenforceable, shall not be affected, and every other term and provision of this Agreement shall be deemed valid and enforceable to the extent permitted by law.

ARTICLE 19 - CITY'S REPRESENTATIVE AND AUTHORITY

The person designated by the CITY MANAGER shall serve as the CITY'S REPRESENTATIVE and shall decide questions which may arise as to quality and acceptability of materials furnished and work performed, and shall interpret the intent of the Contract Documents with reasonable promptness.

The REPRESENTATIVE will not be responsible for the construction means, controls, techniques, sequences, procedures, or construction safety.

The REPRESENTATIVE may assign Project Inspector(s) who shall serve to assist the REPRESENTATIVE in determining if the work performed and the materials used meet the Contract requirements. The Project Inspector shall be authorized to issue Field Orders. The Project Inspector shall be authorized to stop all or any portion of the work if in his opinion the work is not proceeding according to the requirements of the plans and specifications.

ARTICLE 20 - MODIFICATION

The CITY reserves the right to make changes in the work, including alterations, reductions therein or additions thereto. Upon receipt by the CONTRACTOR of the CITY'S notification of a contemplated change, the CONTRACTOR shall (1) if requested by CITY, provide an estimate for the increase or decrease in cost due to the contemplated change, (2) notify the CITY of any estimated change in the completion date, and (3) advise the CITY in writing if the contemplated change shall affect the CONTRACTOR'S ability to meet the completion dates or schedules of this Agreement.

If the CITY so instructs in writing, the CONTRACTOR shall suspend work on that portion of the work affected by a contemplated change, pending the CITY'S decision to proceed with the change.

If the CITY elects to make the change, the CITY shall issue a contract amendment or change order and the CONTRACTOR shall not commence work on any such change until such written amendment or change order has been issued and signed by each of the parties.

ARTICLE 21 - CONTRACT DOCUMENTS

The other documents which comprise the entire Agreement are attached hereto, made a part hereof and consist of the following:

- A. Advertisement for Bids,
- B. Special Instructions and Conditions,
- C. General Instructions and Conditions,
- D. Minimum Technical Specifications,
- E. Bid Forms
Bid Certification Form
Drug-Free Workplace Certification
Public Entity Crimes Statement,
- G. Addendums (if any),
- H. Performance & Payments Bonds (if required),
- I. Change Orders (if any).

In the event of a conflict between the terms of the above documents and the terms of this Agreement, the terms of this Agreement shall prevail.

There are no contract documents other than those listed above and there are no promises or understandings other than those stated herein.

ARTICLE 22 - VENUE

All applicable laws, regulations and ordinances of the State of Florida, Bay County and the City of Callaway will apply to consideration and award of any Bid/Proposal and the performance of the bidder/proposal pursuant thereto, and shall be governed by the laws of the State of Florida both as to intention and performance. The venue for any action arising from the award or subsequent performance shall lie exclusively in the Circuit Court of Bay County, Florida, or the United States District Court for the Northern District of Florida, as applicable.

ARTICLE 23 - NOTICE

All notices required in this Agreement shall be sent by certified mail, return receipt requested, and if sent to the CITY shall be mailed to:

City of Callaway
6601 East Hwy. 22
Callaway, Florida 32404
Attention: Janice L. Peters, City Clerk
Phone: (850) 215-6694
Fax: (850) 871-2224
Email: jpeters@cityofcallaway.com

With a copy to: Kevin D. Obos, Esq. City Attorney
Harrison Sale McCloy
P.O. Drawer 1579
Panama City, FL 32402
Phone: (850) 769-3434
Fax: (850) 769-6121

and if sent to the CONTRACTOR shall be mailed to:

Either party may change its address noted above by giving written notice to the other party in accordance with the requirements of the Section.

This Agreement is entered into as of the day and year first written above and is executed in at least two original copies of which one is to be delivered to the CONTRACTOR, and one to the CITY CLERK for filing in the official records.

CITY CLERK

CITY OF CALLAWAY, FLORIDA

Attest: _____
Janice L. Peters, MMC
City Clerk

By: _____
Keith E. Cook, City Manager

Contractor Witnesses:
(2 REQUIRED)

Contractor:

Witness: _____
Name

Signature

Business Name
By: _____
Signature

Witness: _____
Name

Signature

Print Name and Title

APPROVED AS TO FORM FOR THE RELIANCE OF THE
CITY OF CALLAWAY ONLY:

KEVIN D. OBOS, HARRISON SALE MCCLOY
CITY ATTORNEY



PROPOSAL CHECKLIST
CITY OF CALLAWAY
CHERRY STREET DIRECTIONAL BORE
REBID NO: PW2018-05

**FORMS/ITEMS TO BE RETURNED
WITH YOUR PROPOSAL!**

The following forms are to be completed/signed by the Proposer and submitted to the City:

1. Bid/RFP Certification Form(s),
2. One (1) sets with original signatures, notarized signatures required, plus three (3) copies,
3. Bid Bond or Cashier's Check/Certified Check in the amount of 5% of bid,
4. Proof of Insurance in amounts required by the City with the City listed as Certificate Holder and Additionally Insured (See Special Instructions & Conditions),
5. State of Florida or Bay County Contractor License or Certificate
6. Public Entity Crime Statement,
[Complete items 1 and 6; notarized signature required]
7. Drug-Free Workplace Certification Form,
[Complete Part I; notarized signature, or sign Part II]
8. List of Subcontractors with names of directors or owners, addresses, telephone numbers, and email address (if applicable),
9. List of references for similar type work with contact information.
10. Proprietary/Confidential Information Form

Note: Incomplete Bid/Proposal submissions may not be accepted/considered. Do not modify the forms! Any additional information you desire to present may be included as an attachment.

Reminder: Submit requested number of copies! (See Special Instructions and Conditions)

BID/RFP CERTIFICATION FORM
CITY OF CALLAWAY
CHERRY STREET DIRECTIONAL BORE
REBID NO: PW2018-05

PROPOSERS CERTIFICATION TO THE CITY OF CALLAWAY:

1. The undersigned warrants that: (A) This Proposal is submitted in response to, and is in compliance with, all terms and conditions applicable thereto as set forth in the Advertisement, Instructions to Proposers, General Instructions and Conditions, Special Instructions and Conditions, Bid/RFP Certification Forms, the Minimum Technical Specifications, Addendum, Exhibits, Agreement, Bonds, and Insurance Requirements, each of which has been carefully examined, (B) Proposer or Proposer's representative has made such investigation as is necessary to determine the character and extent of the work and their capability to perform the work, and (C) agrees that if the Proposal is accepted by the City, Proposer will provide the necessary labor, materials, machinery, equipment, tools or apparatus, and perform all the work or services required to complete the assignment and/or contract within the time specified according to the requirements of the City as herein and hereinafter set forth, and (D) he/she is authorized to legally execute binding contracts for and on behalf of the Proposer.

2. Please check one:
 Proposer declares that the only person, persons, company, or parties interested in this Proposal are named in the Proposal.

 Proposer, or one or more of Proposer's officers, principals, or any owner of more than 5% in or of proposer, or members of their immediate families: (A) have a financial interest in another company, project, or property that could benefit financially from this proposed project; and/or (B) another individual or business will be compensated by (or on behalf of proposer) if Proposer is selected by the City for the requested services. (Attach a detailed explanation for either.)

3. Bid Bond - If the Proposal is accepted by the City, it will become a binding contract on both parties. If a Bid Bond or Cashier's Check/Certified Check is required, it shall be submitted with the Proposal. If the undersigned shall fail to deliver or perform, or if applicable, execute a Contract as stated herein, then the City may, at its option, determine that the undersigned has abandoned the Award/Contract, and thereupon such Bid and/or Award shall be null and void, and any Cashier's Check/Certified Check or Bond accompanying this Bid shall be forfeited to and become the property of the City, and the full amount of said check, or if a Bid Bond, the full amount of such bond, shall be paid to the City as partial liquidated damages; otherwise, any Bond or Cashier's Check/Certified Check accompanying this Bid shall be returned to the undersigned within 30 calendar days from the date of Award, or if provisions for a Notice to Proceed are included, from the date of the Notice to Proceed.

4. Vendor proposes and agrees to provide all materials, services or equipment required for the City of Callaway **CHERRY STREET DIRECTIONAL BORE REBID NO: PW2018-05**, for the Total Sum(s) as follows: _____ Dollars (\$ _____).

5. Number of days from date of the Notice to Proceed that will be required for the final completion of all work as described herein.

(Maximum 60 Calendar Days)

6. The City reserves the right to accept any or all prices itemized in any combination that best serves the interests of the City. The City further reserves the right to accept or reject any of the components of this Proposal, including alternates.

7. BIDDER HEREBY ACKNOWLEDGES RECEIPT OF THE FOLLOWING ADDENDUMS: _____

**CITY OF CALLAWAY
CHERRY STREET DIRECTIONAL BORE
REBID NO.: PW2018-05**

	Description	Quantity	Unit	Unit Price	Cost
GENERAL COSTS					
1	Mob/MOT	1	LS		
2	Layout	1	LS		
3	Erosion Control	1	LS		
4	Bonds and Insurance	1	LS		
General Cost Subtotal					\$ -
SITE IMPROVEMENTS					
5	6" Directional Bore	260	LF		
6	6" Gate Valve	2	EA		
7	6" Tapping Saddle and Sleeve	2	EA		
8	Restoration	1	LS		
9	Flowable Fill	1.0	CY		
Site Improvements Subtotal					\$ -
Total Cost					\$ -

Name of Bidder: _____

Business structure: () Corporation, () Partnership, () Individual, () Other: _____

If a Partnership: _____

Name(s) of Partner(s): _____

If a Corporation: _____

Incorporated in State of: _____ Date of Incorporation: _____

Business Address: _____

City: _____ State _____ Zip _____

Telephone Number: () _____ Fax () _____

Submitted By: _____
(Print)

Title: _____

Signature: _____

ATTEST: _____

Secretary

By: _____

Print Name

Affix Corporate Seal
(If Corporation)

State of Florida
County of

The foregoing instrument was acknowledged before me this ___ day of _____, 20__, by _____, who is personally known to me or who presented _____ as identification, and who (did) (did not) take an oath.

[Signature of Notary Public]

[Printed, typed or stamped name of Notary Public]

NOTE: BIDS MAY BE REJECTED IF ALL DOCUMENTS ARE NOT COMPLETE AND EXECUTED, AND THE NUMBER OF COPIES SPECIFIED/REQUESTED OF EACH ARE NOT SUBMITTED WITH THE BID.

**SWORN STATEMENT PURSUANT TO SECTION 287.133(3)(a),
FLORIDA STATUTES, ON PUBLIC ENTITY CRIMES**

THIS FORM MUST BE SIGNED AND SWORN TO IN THE PRESENCE OF A NOTARY PUBLIC OR OTHER OFFICIAL AUTHORIZED TO ADMINISTER OATHS.

1. This sworn statement is submitted to City of Callaway, Florida, a Municipal Corporation, 6601 East Hwy. 22, Callaway, Florida 32404 by _____
[print individual's name and title]
for _____ whose business
[print name of entity submitting sworn statement]
address is _____
_____ and (if applicable) it's Federal Identification Number
(FEIN) is _____ (If the entity has no FEIN, include the Social Security
Number of the individual signing this sworn statement _____)
2. I understand that a "public entity crime" as defined in Paragraph 287.133(1)(g), **Florida Statutes**, means a violation of any state or federal law by a person with respect to and directly related to the transaction of business with any public entity or with an agency or political subdivision of any other state or of the United States, including, but not limited to, any bid or contract for goods or services to be provided to any public entity or any agency or political subdivision of any other state or of the United States and involving antitrust, fraud, theft, bribery, collusion, racketeering, conspiracy, or material misrepresentation.
3. I understand that "convicted" or "conviction" as defined in Paragraph 287.133(1)(b), **Florida Statutes**, means a finding of guilt or a conviction of a public entity crime, with or without an adjudication of guilt, in any federal or state trial court of record relating to charges brought by indictment or information after July 1, 1989, as a result of a jury verdict, non-jury trial, or entry of a plea of guilty or nolo contendere.
4. I understand that an "affiliate" as defined in Paragraph 287.133(1)(a), **Florida Statutes**, means:
 1. A predecessor or successor of a person convicted of a public entity crime; or
 2. An entity under the control of any natural person who is active in the management of the entity and who has been convicted of a public entity crime. The term "affiliate" includes those officers, directors, executives, partners, shareholders, employees, members, and agents who are active in the management of an affiliate. The ownership by one person of shares constituting a controlling interest in another person, or a pooling of equipment or income among persons when not for fair market value under an arm's length agreement, shall be a prima facie case that one person controls another person. A person who knowingly enters into a joint venture with a person who has been convicted of a public entity crime in Florida during the preceding 36 months shall be considered an affiliate.
5. I understand that a "person" as defined in Paragraph 287.133(1)(e), **Florida Statutes**, means any natural person or entity organized under the laws of any state or of the United States with the legal power to enter into a binding contract and which bids or applies to bid on contracts for the provision of goods or services let by a public entity, or which otherwise transacts or applies to transact business with a public entity. The term "person" includes those officers, directors, executives, partners, shareholders, employees, members, and agents who are active in management of an entity.

6. Based on information and belief, the statement which I have marked below is true in relation to the entity submitting this sworn statement. **[Indicate which statement applies.]**

_____ Neither the entity submitting this sworn statement, nor any of its officers, directors, executives, partners, shareholders, employees, members, or agents who are active in the management of the entity, nor any affiliate of the entity has been charged with and convicted of a public entity crime subsequent to July, 1 1989.

_____ The entity submitting this sworn statement, or one or more of its officers, directors, executives, partners, shareholders, employees, members, or agents who are active in the management of the entity, or an affiliate of the entity has been charged with and convicted of a public entity crime subsequent to July 1, 1989.

_____ The entity submitting this sworn statement, or one or more of its officers, directors, executives, partners, shareholders, employees, members, or agents who are active in the management of the entity, or an affiliate of the entity has been charged with and convicted of a public entity crime subsequent to July 1, 1989. However, there has been a subsequent proceeding before a Hearing Officer of the State of Florida, Division of Administrative Hearings and the Final Order entered by the Hearing Officer determined that it was not in the public interest to place the entity submitting this sworn statement on the convicted vendor list. **[attach a copy of the final order]**

I UNDERSTAND THAT THE SUBMISSION OF THIS FORM TO THE CONTRACTING OFFICER FOR THE PUBLIC ENTITY IDENTIFIED IN PARAGRAPH 1 (ONE) ABOVE IS FOR THAT PUBLIC ENTITY ONLY AND, THAT THIS FORM IS VALID THROUGH DECEMBER 31 OF THE CALENDAR YEAR IN WHICH IT IS FILED. I ALSO UNDERSTAND THAT I AM REQUIRED TO INFORM THE PUBLIC ENTITY PRIOR TO ENTERING INTO A CONTRACT IN EXCESS OF THE THRESHOLD AMOUNT PROVIDED IN SECTION 287.017, FLORIDA STATUTES FOR CATEGORY TWO OF ANY CHANGE IN THE INFORMATION CONTAINED IN THIS FORM.

[signature]

PW2018-05

[Reference: RFP Number]

Sworn to and subscribed before me this ___ day of _____, 20___. Personally known _____ or produced identification _____

[Type of identification]

Notary Public - State of _____

My Commission expires: _____

[Signature of Notary]

[Printed, typed or stamped commissioned name of Notary Public]

**CITY OF CALLAWAY
DRUG-FREE WORKPLACE CERTIFICATION**

Please complete Part I or Part II as applicable.

In order to be given preference in the award process for having implemented a drug-free workplace program prior to the Bid/Proposal submission date, the Bidder/Proposer is requested to certify that as part of their drug-free workplace program, they have:

1. Published a statement notifying employees that the unlawful manufacture, distribution, dispensing, possession, or use of a controlled substance is prohibited in the workplace and specified the actions that will be taken against employees for violations of such prohibition.
2. Informed employees about the dangers of drug abuse in the workplace, the business policy of maintaining a drug-free workplace, any available drug counseling, rehabilitation, and employee assistance programs, and the penalties that may be imposed upon employees for drug abuse violations.
3. Given each employee engaged in providing the commodities or contractual services that are under bid a copy of the statement specified in Subsection 1.
4. In the statement specified in Subsection 1, notified the employees that, as a condition of working on the commodities or contractual services that are under bid, the employee will abide by the terms of the statement and will notify the employer of any conviction of, or plea of guilty or nolo contendere to, any violation of Chapter 893 or of any controlled substance law of the United States or any state, for a violation occurring in the workplace no later than five (5) days after such conviction.
5. Imposed a sanction on, or required the satisfactory participation in a drug abuse assistance or rehabilitation program if such is available in the employee's community by any employee who is so convicted.
6. Made a good faith effort to continue to maintain a drug-free workplace through implementation of this section.

Part I - PROGRAM IMPLEMENTED

I certify that I/we have established a drug-free workplace program meeting the foregoing minimum requirements.

[Printed, typed name]

[Signature]

State of Florida

County of _____

The foregoing instrument was acknowledged before me this ____ day of _____, 20__, by _____, who is personally known to me or who presented _____ as identification, and who (did) (did not) take an oath.

[Signature of Notary Public]

[Printed, typed or stamped name of Notary Public]

[Commission Number of Notary Public]

Part II - PROGRAM NOT IMPLEMENTED

A program meeting the above stated requirements has not been established or has not been fully implemented prior to Bid/Proposal closing date, and therefore I/we are not eligible for certification as a drug-free workplace.

[Signature]

[Date]

**PROPRIETARY/CONFIDENTIAL INFORMATION
CHERRY STREET DIRECTIONAL BORE
RFP NO. PW2018-05**

Name of Firm of Bidder/Vendor: _____

Trade secrets or proprietary information submitted by a Vendor shall not be subject to public disclosure under the Freedom of Information Act; however, the Vendor must invoke such protections provided by state law, in writing, either before or at the time the data or other material is submitted. The written notice must specifically identify the data or materials to be protected, including the section of the proposal in which it is contained, as well as the page number(s), and state the reasons why protection is necessary. The proprietary or trade secret material submitted must be identified by some distinct method such as highlighting or underlining and must indicate only the specific words, figures, or paragraphs that constitute a trade secret or proprietary information. In addition, a summary of proprietary information provided shall be submitted on this form. The designation of an entire proposal document, line item prices, and/or total proposal prices as proprietary or trade secrets is not acceptable. If, after being given reasonable time, the Vendor refuses to withdraw such a classification designation, the proposal will be rejected.

SECTION/TITLE	PAGE NUMBER(S)	REASON(S) FOR WITHHOLDING FROM DISCLOSURE

Check this box if there are none.
This document must be completed and returned with proposal.

**CITY OF CALLAWAY
CHERRY STREET DIRECTIONAL BORE
REBID NO: PW2018-05**

**MINIMUM TECHNICAL
SPECIFICATIONS**

**CITY OF CALLAWAY
CHERRY STREET DIRECTIONAL BORE
PROJECT NO. 50093562**

TABLE OF CONTENTS

<u>TECHNICAL SPECIFICATIONS</u>		<u>PAGES</u>
01100	Special Project Procedures	1-5
01110	Environmental Protection	1-6
01340	Submittals	1-4
01705	Project Closeout	1-6
 <u>SITWORK</u>		
02200	Earthwork	1-10
02210	Grassing	1-4
02211	Sodding	1-3
02222	Trenching, Backfilling, and Compacting	1-9
02960	Restoration	1-4
 <u>CONCRETE</u>		
03310	Concrete	1-25
 <u>MECHANICAL</u>		
15010	Basic Mechanical Requirements	1-4
15051	Mechanical Related Work	1-3
15065	Pipe and Fittings	1-5
15070	HDPE Pipe	1-6
15090	Specifications for Ductile Pipe	1-19
15100	Valves and Gates	1-9
15101	Valves and Accessories	1-26

**SECTION 01100
SPECIAL PROJECT PROCEDURES**

PART 1 – GENERAL

1.01 HURRICANE PREPAREDNESS PLAN

- A. Within 20 days of the date of Notice to Proceed, the CONTRACTOR shall submit to the PROJECT REPRESENTATIVE a Hurricane Preparedness Plan. The plan shall outline the necessary measures which the CONTRACTOR proposes to perform at no additional cost to the OWNER in case of a hurricane warning. Such measures shall be in accordance with local and state requirements.
- B. In the event of inclement weather, the CONTRACTOR will, and will cause Subcontractors to, protect carefully the Work and materials against damage or injury from the weather. If, in the opinion of PROJECT REPRESENTATIVE, any portion of Work or materials are damaged or injured by reason of failure on the part of the CONTRACTOR or Subcontractors to so protect the Work, such Work and materials shall be removed and replaced at the expense of CONTRACTOR.

1.02 CONSTRUCTION CONDITIONS AND SUBSURFACE INVESTIGATION

- A. The CONTRACTOR shall strictly adhere to the specific requirements of the government unit(s) or agency(ies) having jurisdiction over the Work. Wherever there is a difference in the requirements of a jurisdictional body and these Specifications, the more stringent shall apply.
- B. The CONTRACTOR shall be responsible for having determined, prior to bid submission, the nature and location of the Work, the conformation of the ground, the character and quality of the substrata, the types and quantity of materials to be encountered, the nature of the groundwater conditions, the character of equipment and facilities needed preliminary to and during the prosecution of the Work, the general and local conditions and all other matters which can in any way affect the Work under this Contract. The prices established for the Work to be done will reflect all costs pertaining to the Work. Any claims for extras based on substrata, groundwater table, and other such conditions will not be allowed.

1.03 PUBLIC NUISANCE

- A. The CONTRACTOR shall not create a public nuisance including, but not limited to, encroachment on adjacent lands, flooding of adjacent lands, excessive noise, or odor.
- B. No extra charge may be made for time lost due to work stoppage resulting from the CONTRACTOR's creation of a public nuisance.

1.04 RELOCATIONS

The CONTRACTOR shall be responsible for the relocation of structures, including, but not limited to, light poles, signs, sign poles, fences, piping, conduits and drains that interfere with the positioning of the work as set out on the Drawings. The cost of all such relocations shall be included in the Contract Price.

1.05 PUMPING

- A. The CONTRACTOR shall accomplish all pumping necessary to prevent flotation of any part of any structures, or pipe/conduit during construction operations.
- B. The CONTRACTOR shall, for the duration of the contract pump out water and wastewater which may seep or leak into the excavations or structures. Galleries and other operating areas shall be kept dry at all times. Discharges shall be in conformance with applicable regulations and permits.

1.06 WORK ON PRIVATE PROPERTY

- A. The CONTRACTOR shall maintain construction operations within the presently existing road right-of-way and established easements throughout the Project. In the event that it becomes necessary or advisable to operate beyond the limits of the existing right-of-way, established easements and Right of Entry Agreements, the CONTRACTOR shall be responsible for securing written agreements with the property owners. Immediately after contract award, the CONTRACTOR shall submit to the PROJECT REPRESENTATIVE a listing of those areas in which it is deemed necessary to work outside of the road right-of-way, easements, or agreements. The listing shall be subject to the approval of the PROJECT REPRESENTATIVE and as construction areas are secured, copies of all written agreements shall be placed on file with the PROJECT REPRESENTATIVE.
- B. The CONTRACTOR shall be responsible for any encroachments on rights-of-way or property of the public or adjoining property owners caused by its operations and shall indemnify, defend and hold the OWNER, ENGINEER and PROJECT REPRESENTATIVE harmless because of any encroachments. In this regard, the CONTRACTOR shall, without extra cost to the OWNER, move any Work or that portion of any Work that encroaches on the property of others, or that is built beyond legal building or setback limits, and the CONTRACTOR shall rebuild the affected Work or portion of Work at the proper location and in full compliance with the Contract Documents.
- C. Before final payment will be authorized, the CONTRACTOR will be required to furnish the OWNER with written releases from property owners or public agencies where side agreements or special easements have been made by the CONTRACTOR or when the CONTRACTOR'S operations, for any reason, have not been kept within the construction right-of-way, easements or Right of Entry

Agreements by the OWNER.

- D. In the event written releases required in the above paragraph cannot be secured, the CONTRACTOR shall inform the PROJECT REPRESENTATIVE of the reasons for failure to do so. The PROJECT REPRESENTATIVE in conjunction with the OWNER, will then examine the Site and direct the CONTRACTOR to complete any Work that may be necessary to satisfy the terms of the permit or easement. Should the CONTRACTOR refuse to do the Work, the OWNER reserves the right to have the Work done by separate contract and deduct the cost of same from moneys due the CONTRACTOR, or require the CONTRACTOR to furnish a bond in a sum satisfactory to the OWNER to cover any legal claims for damages. When the PROJECT REPRESENTATIVE is satisfied that the Work has been completed in accordance with the Contract Documents, permits and/or agreements, the OWNER reserves the right to waive the requirement of obtaining the statement if the CONTRACTOR'S failure to obtain such statement is due to the grantor's refusal to sign and this refusal is not based upon any legitimate claims that the CONTRACTOR has failed to fulfill any contract permit or agreement requirements, or if the CONTRACTOR is unable to contact, or has undue hardship in contacting, the grantors.

1.07 DAILY REPORTS

- A. The CONTRACTOR shall submit daily reports of construction activities, including any activities that may occur on non-work days. The report shall include:
1. Weather conditions.
 2. Manpower, number of men by craft.
 3. Equipment on the project.
 4. Major deliveries.
 5. Activities work with reference to the CPM schedule activity numbers.
 6. New problems.
 7. Other pertinent information.
- B. A similar report shall be submitted for/by each Subcontractor.
- C. The reports shall be submitted to the PROJECT REPRESENTATIVE within 2 days of the respective report date. Each report shall be signed by the CONTRACTOR'S Superintendent or Project Manager.
- D. Information provided on the daily report shall not constitute notice of delay or any

other notice required by the CONTRACT DOCUMENTS. Notice shall be as required therein.

1.08 EMERGENCIES

- A. The CONTRACTOR shall at all times after regular working hours, including weekend and holidays, maintain a telephone where the CONTRACTOR's representative can be reached on an emergency basis. The CONTRACTOR or CONTRACTOR's representative shall be prepared to act to correct conditions on the Site deemed to constitute an emergency by either the OWNER, the PROJECT REPRESENTATIVE, or local authorities and is obligated to act to prevent threatened damage, injury or loss without special instructions from the OWNER, PROJECT REPRESENTATIVE, or ENGINEER. The CONTRACTOR shall give the PROJECT REPRESENTATIVE prompt written notice of all significant changes in the Work or deviations from the Contract Documents caused thereby. If a condition on the Site requires attention after working hours, either the OWNER, PROJECT REPRESENTATIVE, or local authority shall call the CONTRACTOR or representative at the emergency telephone number, identify themselves and describe the emergency condition. The CONTRACTOR is expected to dispatch personnel and equipment to adequately institute corrective measures within 2 hours. If for some reason the CONTRACTOR or representative cannot be reached at the emergency number within two hours, the OWNER shall have the right to immediately initiate corrective measures, and the cost shall be borne by the CONTRACTOR.
- B. In the event that the CONTRACTOR fails to maintain safe job conditions and traffic conditions, including, but not limited to, trench settlement and hazardous storage of backfill or construction materials, the OWNER, after failure of the CONTRACTOR to commence substantial steps at the job site to rectify the situation within 2 hours of the time the CONTRACTOR has been notified of the unsafe condition, may hire guards, take such precautions, make such repairs and take any other steps which the OWNER or the PROJECT REPRESENTATIVE, in their sole discretion, consider necessary to protect the property, persons, or the OWNER. The cost of any of these precautions, guards, or steps shall be deducted from the payments due the CONTRACTOR, and the costs for such services, work and material shall be calculated at prevailing market rates.

1.09 PROPERTY DAMAGES

In the event of any indirect or direct damage to public or private property caused in whole or in part by an act, omission or negligence on the part of the CONTRACTOR, any of its Subcontractors, any of its Sub-subcontractors or anyone directly or indirectly employed by any of them or by anyone for whose acts any of them may be liable, the CONTRACTOR shall at no additional cost to OWNER promptly remedy and restore such property to a condition equal to or better than that existing before such damage was done. The CONTRACTOR shall perform such restoration by "underpinning", repairing,

rebuilding, replanting, or otherwise restoring as may be required by the PROJECT REPRESENTATIVE, or shall correct such damage in a satisfactory and acceptable manner to the OWNER or the PROJECT REPRESENTATIVE. In case of failure on the part of the CONTRACTOR to promptly restore such property or correct such damage, the OWNER may, upon 5 calendar days written notice, proceed to repair, rebuild or otherwise restore such property as may be necessary and the cost thereof, or a sum sufficient in the judgment of the OWNER to reimburse the owners of the property so damaged, will be deducted from any monies due or to become due the CONTRACTOR under the Contract.

PART 2 – PRODUCTS (Not Applicable)

PART 3 – EXECUTION (Not Applicable)

END OF SECTION

**SECTION 01110
ENVIRONMENTAL PROTECTION**

1.01 SCOPE OF WORK

- A. The Work covered by this Section consists of furnishing all labor, materials and equipment and performing all Work required for the prevention of environmental pollution in conformance with applicable laws and regulations, during and as the result of construction operations under this Contract. For the purpose of this Specification, environmental pollution is defined as the presence of chemical, physical, or biological elements or agents which adversely affect human health or welfare; unfavorably alter ecological balances of importance to human life; affect other species of importance to man; or degrade the utility of the environment for aesthetic and/or recreational purposes; or violate any applicable environmental laws, rules, codes or regulations.
- B. The control of environmental pollution requires consideration of air, water and land, and involves management of noise, odor, and solid waste, as well as other pollutants.
- C. These Specifications are intended to ensure that construction is achieved with a minimum of disturbance to the existing ecological balance between a water resource and surroundings. These are general guidelines. It is the CONTRACTOR'S responsibility to determine the specific construction techniques to meet these guidelines.
- D. The CONTRACTOR shall secure, if required, at its own cost, a surface water management permit from the Northwest Florida Water Management District and approvals from Bay County and/or City of Callaway for any construction dewatering activities associated with this project.

1.02 APPLICABLE REGULATIONS

The CONTRACTOR shall comply with all applicable Federal, State and local laws and regulations concerning environmental pollution control and abatement.

1.03 NOTIFICATIONS

The OWNER through the PROJECT REPRESENTATIVE will notify the CONTRACTOR in writing immediately following identification of any non-compliance with the foregoing provisions or of any environmentally objectionable acts and any required corrective action to be taken by CONTRACTOR. State or local agencies responsible for verification of certain aspects of the environmental protection requirements may notify the CONTRACTOR of any non-compliance with State or local requirements.

The CONTRACTOR shall, after receipt of such notice from the regulatory agency shall immediately notify the PROJECT REPRESENTATIVE in writing and immediately take correction action. If the CONTRACTOR fails or refuses to comply promptly, the OWNER may issue an order stopping all or part of the Work until satisfactory corrective action has been taken. No part of the time lost due to any such stop orders shall be made the subject of a claim for extension of time or for excess costs or damages by the CONTRACTOR unless it is later determined that the CONTRACTOR was in compliance and subject to the other terms of the Contract Documents.

1.04 IMPLEMENTATION

- A. Prior to commencement of the Work, the CONTRACTOR shall meet with the PROJECT REPRESENTATIVE to develop mutual understandings relative to compliance with this specification and administration of the environmental pollution control program.
- B. The CONTRACTOR shall remove temporary environmental control features, when approved by the PROJECT REPRESENTATIVE, and incorporate permanent control features into the Project at the earliest practicable time, consistent with the approved construction schedule.

1.05 EROSION CONTROL

- A. The CONTRACTOR shall ensure sufficient precautions are taken during construction to minimize the run-off of polluting substances such as silt, clay, fuels, oils, bitumens, calcium chloride, or other polluting materials harmful to humans, fish, or other life, into the supplies and surface waters of the State. Control measures must be adequate to assure that turbidity in the receiving water will not be increased more than 10 nephelometric turbidity units (NTU), or as otherwise required by the State or other controlling body, in water used for public water supply or fish unless limits have been established for the particular water. In surface water used for other purposes, the turbidity must not exceed 25 NTU unless otherwise permitted. Special precautions shall be taken in the use of construction equipment to prevent operations which promote erosion.

Erosion evident within the limits of construction shall be the responsibility of the CONTRACTOR during the full term of the Contract and for the full (1) year guarantee period. Areas subject to erosion during this time shall be fully restored to original or design conditions (as applicable) within 10 days of notice to the CONTRACTOR.

- B. The CONTRACTOR shall provide positive means of erosion control such as shallow ditches around construction to carry off surface water. Erosion control measures, such as siltation basins, hay check dams, mulching, jute netting and other equivalent techniques, shall be used as appropriate. Flow of surface water into excavated areas shall be prevented.

Ditches around construction area shall be used to carry away water resulting from dewatering of excavated areas. At the completion of the Work, ditches shall be backfilled and the ground surface restored to original condition.

- C. The CONTRACTOR shall schedule and conduct all Work in a manner that will minimize the erosion of soils in the area of the Work. Erosion control measures shall be provided such as diversion channels, sedimentation or filtration systems, berms, staked hay bales, seeding, mulching or other special surface treatments as are required by regulatory authorities to prevent silting and muddying of streams, rivers, canals, impoundments, lakes, etc. All erosion control measures shall be in place prior to any construction activity in any area of the Work.

1.06 PROTECTION OF LAND RESOURCES

- A. Land resources within the Project boundaries and outside the limits of permanent Work shall be restored by CONTRACTOR to a condition, after completion of construction that will appear to be natural and not detract from the appearance of the project.
- B. Outside of areas requiring earthwork for the construction of the new facilities, the CONTRACTOR shall not deface, injure, or destroy trees or shrubs, nor remove or cut them without prior approval. No ropes, cables, or guys shall be fastened to or attached to any existing nearby trees for anchorage unless specifically authorized by the PROJECT REPRESENTATIVE. Where such special emergency use is permitted, first wrap the trunk with a sufficient thickness of burlap or rags over which softwood cleats shall be tied before any rope, cable, or wire is placed. The CONTRACTOR shall in any event be responsible for any damage resulting from such use.
- C. Where trees may possibly be defaced, bruised, injured, or otherwise damaged by the CONTRACTOR'S equipment, dumping or other operations, CONTRACTOR shall protect such trees by placing board, planks, or poles around them. Monuments and markers shall be similarly protected by CONTRACTOR before beginning operations near them.
- D. Any trees or other landscape feature scarred or damaged by the CONTRACTOR'S equipment or operations shall be restored as nearly as possible to its original condition. The PROJECT REPRESENTATIVE will decide what method of restoration shall be used and whether damaged trees shall be treated and healed or removed and disposed of.

All scars made on trees by CONTRACTOR's equipment, construction operations, or by the removal of limbs by CONTRACTOR larger than 1 inch in diameter shall be coated as soon as possible with an approve tree wound dressing.

All trimming or pruning by CONTRACTOR shall be performed in an approved manner by experienced workmen with saws or pruning shears. Tree trimming with axes will not be permitted.

Climbing ropes shall be used where necessary for safety. Trees that are to remain, either within or outside established clearing limits, that are subsequently damaged by the CONTRACTOR and are beyond saving in the opinion of a certified nurseryman, shall be immediately removed and replaced in kind and maintained until growth is assured.

- E. The locations of the CONTRACTOR's lay down area, storage and other construction buildings, required temporarily in the performance of the Work, shall require written concurrence of the PROJECT REPRESENTATIVE. The preservation of the landscape and public perception shall be an imperative consideration in the selection of the lay down area and in the provision of any buildings. Drawings showing the lay down area and any buildings shall be submitted by CONTRACTOR for approval of the PROJECT REPRESENTATIVE.
- F. If temporary roads or embankments and excavations for plant and/or work areas are proposed, the CONTRACTOR shall submit the following for approval by the PROJECT REPRESENTATIVE at least ten days prior to scheduled start of such temporary work.
1. A layout of all temporary roads, excavations and embankments to be constructed within the work area.
 2. Details of temporary road construction.
 3. Drawings and cross sections of proposed embankments and their foundations, including a description of proposed materials.
 4. A landscaping drawing showing the proposed restoration of the area. Removal of any trees and shrubs outside the limits of existing clearing area shall be indicated. The drawing shall also indicate location of required guard posts or barriers required to control vehicular traffic passing close to trees and shrubs to be maintained undamaged. The drawing shall provide for the obliteration of construction scars as such and shall provide for a natural appearing final condition of the area. Modification of the CONTRACTOR'S approved drawings shall be made only with the written concurrence of the PROJECT REPRESENTATIVE.

No unauthorized road construction, excavation or embankment construction including disposal areas will be permitted.

- G. The CONTRACTOR shall remove all signs of temporary construction facilities such as haul roads, work areas, structures, foundations of temporary structures, stockpiles of excess materials, or any other vestiges of construction as requested by the PROJECT REPRESENTATIVE. Any construction disturbed area shall be restored to near natural conditions.
- H. All debris and excess material will be disposed of by CONTRACTOR outside wetland or floodplain areas in an environmentally sound and lawful manner.

1.07 PROTECTION OF AIR QUALITY

- A. The use of burning for the disposal of refuse and debris will not be permitted.
- B. The CONTRACTOR shall maintain all excavations, embankment, stockpiles, access roads, plant sites, waste areas, borrow areas, and all other work areas within or without the project boundaries free from dust which could cause the standards for air pollution to be exceeded, and which would cause a hazard or nuisance to others.
- C. An approved method of stabilization consisting of sprinkling or other similar methods will be permitted to control dust. The use of petroleum products is prohibited. The use of chlorides may be permitted with concurrence from the appropriate regulatory authority.
- D. Sprinkling must be repeated at such intervals as to keep all parts of the disturbed area at least damp at all times, and the CONTRACTOR must have sufficient competent equipment on the job to accomplish needed sprinkling. Dust control shall be performed as the work proceeds and whenever a dust nuisance or hazard occurs.

1.08 MAINTENANCE OF POLLUTION CONTROL FACILITIES DURING CONSTRUCTION

During the life of this Contract, CONTRACTOR shall maintain all facilities constructed for pollution control as long as the operations creating the particular pollutant are being carried out or until the material concerned has become stabilized to the extent that pollution is no longer being created. All pollution control devices shall be inspected regularly to ensure they are operating correctly.

1.09 NOISE CONTROL

- A. The CONTRACTOR shall make every effort to minimize noises caused by operations. Equipment shall be equipped with silencers or mufflers designed to operate with the least possible noise in compliance with State and Federal Regulations.

- B. Sound levels measured by the PROJECT REPRESENTATIVE shall not exceed 55 dBA from 8:00 PM to 7:00 AM or 65 dBA from 7:00 AM to 8:00 PM. This sound level to be measured at the OWNER'S property line. Sound levels of equipment shall not exceed 95 dBA at any time. Sound levels in excess of these values are sufficient cause to have the Work halted until equipment can be quieted to acceptable levels. Work stoppage for excessive noise shall not relieve the CONTRACTOR of the other portions of this specification including, but not limited to Contract Time and Contract Price.

PART 2 – PRODUCTS (Not Applicable)

PART 3 – EXECUTION (Not Applicable)

END OF SECTION

**SECTION 01340
SUBMITTALS**

PART 1 - GENERAL

1.01 RELATED DOCUMENTS

- A. Drawings and general provisions of Contract apply to Work of this section.

1.02 DESCRIPTION OF REQUIREMENTS:

- A. The types of submittal requirements specified in this section include Shop Drawings, product data, samples, and miscellaneous work-related submittals.
- B. Individual submittal requirements are specified in applicable sections for each unit of work.
- C. Refer to other sections and other Contract Documents for requirements of administrative submittals.

1. Definitions:

- a) Work-related submittals of this section are categorized for convenience as follows:
- 1) Shop drawings include specially-prepared technical data for this project, including drawings, diagrams, performance curves, data sheets, schedules, templates, patterns, reports, calculations, instructions, measurements and similar information not in standard printed form for general application to a range of similar projects.
 - 2) Product data includes standard printed information on materials, products and systems; not specially-prepared for this Project, other than the designation of selections from among available choices printed therein.
 - 3) Miscellaneous submittals directly related to the Work (non-administrative) include warranties, maintenance agreements, workmanship bonds, project photographs, survey data and reports, physical work records, quality testing and certifying reports, copies of industry standards record drawings, field measurements data, operating and maintenance materials, overrun stock, and similar information, devices and materials applicable to the Work and not processed as Shop Drawings, product data or samples.

1.03 SUBMITTAL REQUIREMENTS

A. General:

1. Except as otherwise indicated in individual work sections, comply with requirements specified herein for each indicated category of submittal. Provide and process intermediate submittals (where required between initial and final) similar to initial submittals.

B. Shop Drawings:

1. Provide newly-prepared information with graphic information at accurate scale (except as otherwise indicated), with name of preparer indicated (firm name).
2. Show dimensions and note which are based on field measurement.
3. Identify materials and products in the work shown.
4. Indicate compliance with standards, and special coordination requirements.
5. Do not allow shop drawing copies without appropriate final approval markings by ENGINEER to be used in connection with the Work.
6. Submit five copies of all Shop Drawings. The ENGINEER will maintain two copies for his records, if more is needed by the CONTRACTOR, then the extra required number should be submitted.
7. Product Data:
 - a) Collect required data into one submittal for each unit of work or system; and mark each copy to show which choices and options are applicable to project.
 - b) Include manufacturer's standard printed recommendations for application and use, compliance with standards, application of labels and seals, rotation of field measurements which have been checked, and special coordination requirements.
 - c) Maintain one set of product data (for each submittal) at Project site, available for reference by ENGINEER or others.
8. Submittals:
 - a) Do not submit product data or allow its use on Project until compliance with requirements of Contract Documents has been

confirmed by CONTRACTOR. Submittal is for information and record, unless otherwise indicated.

- b) Note that the initial submittal is regarded as the final submittal unless returned promptly by ENGINEER marked with "Revise and Resubmit" which indicates an observed non-compliance.
- c) Submit three copies, plus two additional copies (which will be returned) where required for maintenance manuals.

9. Warranties:

- a) Refer to Section 00100 for specific general requirements on warranties, product/workmanship bonds, and maintenance agreements. In addition to copies desired for Contractor's use, furnish three executed copies, except furnish two additional (conformed) copies where required for maintenance manuals.

10. Closeout Submittals:

- a) Refer to individual Work sections and to Section 01705 - "Project Closeout" for specific requirements on submittal of closeout information, materials, tools, and similar items.

11. Maintenance/Operating Manuals:

- a) Furnish five bound copies to ENGINEER.

12. Materials and Tools:

- a) Refer to individual Work sections for required quantities of spare parts, extra and overrun stock, maintenance tools and devices, keys and similar physical units to be submitted.

1.04 ACTION OF SUBMITTAL

A. ENGINEER's Action:

- 1. Where action and return is required or requested, the ENGINEER will review each submittal, mark with revise and resubmit, and where possible return within 2 weeks of receipt.
- 2. Where submittal must be held for coordination, the CONTRACTOR will be so advised by the ENGINEER without delay.

B. Action Stamp:

CITY OF CALLAWAY CHERRY STREET DIRECTIONAL BORE

1. ENGINEER's action stamp, for use on submittals to be returned to the CONTRACTOR, is self-explanatory as marked.

PART 2 - PRODUCTS (Not Applicable)

PART 3 - EXECUTION (Not Applicable)

END OF SECTION

**SECTION 01705
PROJECT CLOSEOUT**

PART 1 - GENERAL

1.01 RELATED DOCUMENTS

- A. Drawings and general provisions of Contract apply to work of this section.

1.02 DESCRIPTION OF REQUIREMENTS

A. Definitions:

1. Closeout is hereby defined to include general requirements near the end of Contract Time, in preparation for final acceptance, final payment, normal termination of Contract, and similar actions evidencing completion of the Work.
 - a) Specific requirements for individual units of work are specified elsewhere in these Specifications.
2. Time of closeout is directly related to "Substantial Completion," and therefore; may be either a single time period for entire Work or a series of time periods for individual parts of the Work which have been certified as substantially complete at different dates.
 - a) That time variation (if any) shall be applicable to other provisions of this section.

1.03 PREREQUISITES FOR SUBSTANTIAL COMPLETION

A. General:

1. Prior to requesting ENGINEER's inspection for certification of Substantial Completion (for either entire work or portions thereof), complete the following and list known exceptions in request:
2. In progress payment request, coincident with or first following date claimed, show either 100% completion for portion of Work claimed as "substantially complete" or list incomplete items, value of incompleteness, and reasons for being incomplete.
3. Include supporting documentation for completion as indicated in these Contract Documents.
4. Submit statement showing accounting of changes to the Contract Sum.

5. Advise OWNER of pending insurance change-over requirements.
6. Submit special warranties, workmanship/maintenance bonds, maintenance agreements, final certifications, and similar documents.
7. Obtain and submit releases enabling OWNER's full and unrestricted use of the work and access to services and utilities, including (where required) operating certificate, and similar releases.
8. Submit record drawings, maintenance manuals, and similar final record information.
9. Deliver tools, spare parts, extra stocks of materials, and similar physical items to the OWNER.
10. Make final change-over of locks and transmit keys to OWNER, and advise OWNER's personnel to change-over in security provisions, applicable.
11. Complete start-up testing of systems, and instructions of OWNER's operating/maintenance personnel. Discontinue (or change over) and remove from Project site temporary facilities and services, along with construction tools and facilities, mock-ups, and similar elements.
12. Complete final cleaning up requirements, including touch-up painting of marred surfaces.

B. Inspection Procedures:

1. Upon receipt of CONTRACTOR's request, the ENGINEER will either proceed with inspection or advise CONTRACTOR of prerequisites not fulfilled.
2. Following initial inspection, the ENGINEER will either prepare certificate of Substantial Completion, or advise the CONTRACTOR of work which must be performed prior to issuance of certificate; and repeat inspection when requested and assured that work has been substantially completed.
3. Results of completed inspection will form initial "punch-list" for final acceptance.

1.04 PREREQUISITES FOR FINAL ACCEPTANCE

A. General:

1. Prior to requesting ENGINEER's final inspection for certification of final acceptance and final payment, as required by General Conditions (Section 00100), complete the following and list known exceptions (if any) in request:

CITY OF CALLAWAY CHERRY STREET DIRECTIONAL BORE

- a) Submit final payment request with final releases and supporting documentation not previously submitted and accepted. Include certificates of insurance for products and completed operations where required.
- b) Submit updated final statement, accounting for additional (final) changes to the Contract Sum.
- c) Submit consent of surety.
- d) Submit final liquidation damages settlement statement, acceptable to the OWNER.
- e) Revise and submit evidence of final continuing insurance coverage complying with insurance requirements.

B. Reinspection Procedure:

1. Upon receipt of CONTRACTOR's notice that the work has been completed, including punch-list items resulting from earlier inspections, and excepting incomplete items delayed because of acceptable circumstances, the ENGINEER will reinspect the Work.
2. Upon completion of reinspection, the ENGINEER will either prepare a certificate of final acceptance or advise the CONTRACTOR of Work not completed or obligations not fulfilled as required for final acceptance.
3. If necessary, procedure will be repeated.

1.05 RECORD DOCUMENT SUBMITTALS

A. General:

1. Specific requirements for record documents are indicated in individual sections of these specifications. Other requirements are indicated in General Conditions. General submittal requirements are indicated in Section 01300 (Submittals).
2. Do not use record documents for construction purposes; protect from deterioration and loss in a secure fire-resistive location; provide access to record documents for engineer's reference during normal working hours.

B. Record Drawings:

1. Maintain a set of contract drawings and shop drawings in clean, undamaged condition, with mark-up of actual installations which vary substantially from the work as originally shown.

2. Mark whichever drawing is most capable of showing "field" condition fully and accurately; however, where shop drawings are used for mark-up, record a cross-reference at corresponding location on working drawings.
3. Mark with red erasable pencil and, where feasible, use other colors to distinguish between variations in separate categories of work.
4. Mark-up new information which is recognized to be of importance to the OWNER, but was for some reason not shown on either the Drawings or Shop Drawings. Give particular attention to concealed work, which would be difficult to measure and record at a later date.
5. Note related Change Order numbers where applicable.

C. Record Specifications:

1. Maintain one copy of specifications, including Addenda, Change Orders and similar modifications issued in printed form during construction, and mark-up variation (of substance) in actual work in comparison with text of Specifications and modifications as issued.
2. Give particular attention to substitutions, selection of options, and similar information on Work where it is concealed or cannot otherwise be readily discerned at a latter date by direct observation.
3. Note related Record Drawing information and product data, where applicable.
4. Submit mark-up upon completion to the ENGINEER for the OWNER's records.

D. Maintenance Manuals:

1. Organize maintenance-and-operating manual information into suitable sets of manageable size, and bind into individual binders properly identified and indexed (thumb tabbed). Four sets will be required.
2. Include emergency instructions, spare parts listing, warranties' copies, wiring diagrams, recommended "turn-around" cycles, inspection procedures, shop drawings, product data, and similar applicable information.

PART 2 - PRODUCTS (Not Applicable)

PART 3 - EXECUTION

3.01 CLOSEOUT PROCEDURES

A. General Operating/Maintenance Instructions:

1. Arrange for each installer of work requiring continuing maintenance or operating to meet with OWNER's personnel, at Project site, to provide basic instructions needed for proper operation and maintenance of entire Work.
2. Include instructions by manufacturer's representatives where installers are not expert in the required procedures.
3. Review maintenance manuals, record documentation, tools, spare parts and materials, lubricants, fuels, identification systems, control sequences, hazards, cleaning, and similar procedures and facilities.
4. Demonstrate start-up, shut-down, emergency operations, noise and vibration adjustments, safety, economy/efficiency adjustments, energy effectiveness, and similar operations for operational equipment.
5. Review maintenance and operations in relation with applicable warranties, agreements to maintain, bonds, and similar continuing commitments.

3.02 FINAL CLEANING

A. General:

Special cleaning for specific units of work is specified in other sections. The following are examples, but not by way of limitation, of cleaning levels required:

1. Remove labels which are not required as permanent labels.
2. Wipe surfaces of mechanical and electrical equipment clean and remove excess lubrication and other substances.
3. Clean Project site (yard and grounds), including landscape development areas, of litter and foreign substances.
4. Sweep paved areas to a broom-clean condition; remove stains, petro-chemical spills and other foreign deposits.
5. Rake grounds which are neither planted nor paved, to a smooth, even-textured surface.

CITY OF CALLAWAY CHERRY STREET DIRECTIONAL BORE

B. Compliances:

1. Comply with safety standards and governing regulations for cleaning operations.
2. Do not burn waste materials at site, or bury debris or excess materials on OWNER's property, or discharge volatile or other harmful or dangerous materials into drainage systems.
3. Remove waste materials from site and dispose of in a lawful manner.
4. Dispose of extra materials of value remaining after completion of the associated Work has become the OWNER's property, to OWNER' best advantage as directed.

END OF SECTION

**SECTION 02200
EARTHWORK**

PART 1 - GENERAL

1.01 RELATED DOCUMENTS

- A. Drawings and general provisions of Contract, including General and Special Conditions, apply to work of this section.

1.02 DESCRIPTION OF WORK

- A. Definition: "Excavation" consists of removal of material encountered to subgrade elevations indicated and subsequent disposal of materials removed.

1.03 QUALITY ASSURANCE

- A. Codes and Standards:

- 1. Perform excavation work in compliance with applicable requirements of governing authorities having jurisdiction.

- B. Testing and Inspection Service:

- 1. Employ, at CONTRACTOR's expense, a testing laboratory subject to approval by the ENGINEER to perform soil testing and inspection service for quality control during earthwork operations.

1.04 SUBMITTALS

- A. Test Reports-Excavating: Submit following reports directly to ENGINEER from the testing services; with copy to CONTRACTOR:

- 1. Test reports on fill material. (Modified Proctor Tests)
- 2. Field density test reports. (Modified Proctor Tests)
- 3. Report of actual unconfined compressive strength and/or results of bearing tests of each stratum tested.

1.05 JOB CONDITIONS

- A. Existing Utilities:

- 1. Locate existing underground utilities in areas of work. If utilities are to remain in place, provide adequate means of support and protection during earthwork operations.

2. Should uncharted, or incorrectly charted, piping or other utilities be encountered during excavation, consult utility owner immediately for directions. Cooperate with OWNER and utility companies in keeping respective services and facilities in operation. CONTRACTOR shall bear all costs of repairing damaged utilities to the satisfaction of utility owner.
 3. Do not interrupt existing utilities serving facilities occupied and used by OWNER or others, during occupied hours, except when permitted in writing by ENGINEER and then only after acceptable temporary utility services have been provided.
 4. Provide minimum of 48-hour notice to engineer, and receive notice to proceed before interrupting any utility.
 5. Demolish and completely remove from site existing underground utilities indicated to be removed. Coordinate with utility companies for shut-off of services if lines are active.
- B. Use of explosives:
1. The use of explosives is not permitted.
- C. Protection of Persons and Property:
1. Barricade open excavations occurring as part of this work and post with warning lights.
 2. Operate warning lights as recommended by authorities having jurisdiction.
 3. Protect structures, utilities, sidewalks, pavements, and other facilities from damages caused by settlement, lateral movement, undermining, washout, and other hazards created by earthwork operations.
 4. Perform excavation within drip-line of large trees to remain by hand, and protect the root system from damage or dryout in the manner prescribed in sections under "Sitework."

PART 2 - PRODUCTS

2.01 SOILS MATERIALS

- A. Subbase Material:
1. Naturally or artificially graded mixture of natural or crushed gravel, crushed stone, crushed slag, natural or crushed sand.
- B. Backfill and Fill Materials:

1. Satisfactory soil materials free of clay, rock or gravel larger than 2 inches in any dimension, debris, waste, frozen materials, vegetation and other deleterious matter. The fill material should be sand containing little fines.
2. Prior to placing the fill material, the existing material shall be stripped of all soils containing a significant percentage of organics and all loose soils which cannot be readily compacted.
3. If existing materials do not meet these requirements, it may be necessary to backfill with select materials other than those on the job site.

PART 3 - EXECUTION

3.01 EXCAVATION

A. Excavation:

1. Excavation is Unclassified, and includes excavation to subgrade elevations indicated, regardless of character of materials and obstructions encountered.
2. Unauthorized excavation consists of removal of materials beyond indicated subgrade elevations or dimensions without specific direction of ENGINEER. Unauthorized excavation, as well as remedial work directed by ENGINEER, shall be at CONTRACTOR's expense.
3. Under footings, foundation bases, or retaining walls, fill unauthorized excavation by extending indicated bottom of elevation of footing or base to excavation bottom, without altering required top elevation. Lean concrete fill may be used to bring elevations to proper position, when acceptable to ENGINEER.
4. Elsewhere, backfill and compact unauthorized excavations as specified for authorized excavations of same classifications, unless otherwise directed by engineer.

B. Additional Excavation:

1. When excavation has reached required subgrade elevations, notify ENGINEER who will make an inspection of conditions.
2. If unsuitable bearing materials are encountered at required subgrade elevations, notify ENGINEER who will make an inspection of conditions.
3. If unsuitable bearing materials are encountered at required subgrade elevations, carry excavations deeper and replace excavated material as directed by the ENGINEER.

4. Removal of unsuitable material and its replacement as directed will be paid on basis of contract conditions relative to changes in work.

C. Stability of Excavations:

1. Slope sides of excavations to comply with local codes and ordinances having jurisdiction. Shore and brace where sloping is not possible because of space restrictions or stability of material excavated.
2. Maintain sides and slopes of excavations in safe condition until completion of backfilling.

3.04 SHORING AND BRACING

- A. Provide materials for shoring and bracing, such as sheet piling, uprights, stringers and cross-braces, in good serviceable condition.
- B. Establish requirements for trench shoring and bracing to comply with local codes and authorities having jurisdiction.
- C. Maintain shoring and bracing in excavations regardless of time period excavations will be open. Carry down shoring and bracing as excavation progresses.
- D. Dewatering:
 1. Prevent surface water and subsurface or ground water from flowing into excavations and from flooding project site and surrounding area. The cost of all dewatering operations including well pointing and "sock pipe" shall be the responsibility of the CONTRACTOR. The ENGINEER may direct the CONTRACTOR to provide dewatering if deemed necessary.
 2. Do not allow water to accumulate in excavations. Remove water to prevent softening of foundation bottoms, undercutting footings, and soil changes detrimental to stability of subgrades and foundations. Provide and maintain pumps, well points, sumps, suction and discharge lines, and other dewatering system components necessary to convey water away from excavations.
 3. Establish and maintain temporary drainage ditches and other diversions outside excavation limits to convey rain water and water removed from excavations to collecting or run-off areas. Do not use trench excavations as temporary drainage ditches.
- E. Material Storage:
 1. Stockpile satisfactory excavated materials where directed, until required for backfill or fill. Place, grade, and shape stockpiles for proper drainage.

2. Locate and retain soil materials away from edge of excavations. Do not store within drip line of trees indicated to remain.
3. Dispose of excess soil material and waste materials as herein specified.

F. Excavation for Structures:

1. Conform to elevations and dimensions shown within a tolerance of plus or minus 0.10', and extending a sufficient distance from footings and foundations to permit placing and removal of concrete formwork, installation of service, other construction, and for inspection.
2. In excavating for footings and foundations, take care not to disturb bottom of excavation. Excavate by hand to final grade just before concrete reinforcement is placed. Trim bottoms to required lines and grades to leave solid base to receive other work.

G. Excavation for Trenches:

1. Dig trenches to the uniform width required for particular item to be installed, sufficiently wide to provide ample working room. Provide 6" to 9" clearance on both sides of pipe or conduit and a maximum of 30" total width.
2. Excavate trenches to depth indicated or required. Carry depth of trenches for piping to establish indicated flow lines and invert elevations. Beyond building perimeter, keep bottoms of trenches sufficiently below finish grade to avoid freeze-ups.
3. Where rock is encountered, carry excavation 6" below required elevation and backfill with a 6" layer of crushed stone or gravel prior to installation of pipe.
4. For pipes or conduit 5" or less in nominal size and for flat-bottomed multiple-duct conduit units, do not excavate beyond indicated depths. Hand excavate bottom cuts to accurate elevations and support pipe or conduit on undisturbed soil.
5. For pipes or conduit 6" or larger in nominal size, tanks and other mechanical/electrical work indicated to receive subbase, excavate to subbase depth indicated, or, if not otherwise indicated, to 6" below bottom of work to be supported.
6. Except as otherwise indicated, excavate for waterbearing piping so top of piping is not less than 3'-0" below finished pavement grade, but no less than 2'-6" below finish grade.
7. Grade bottoms of trenches as indicated, notching under pipe bells to provide

solid bearing for entire body of pipe.

8. Backfill trenches with concrete where trench excavations pass within 18" of column or wall footings and which are carried below bottom of such footings, or which pass under wall footings. Place concrete to level of bottom of adjacent footing.
9. Use care in backfilling to avoid damage or displacement of pipe systems.

3.02 COMPACTION

A. General:

1. Control soil compaction during construction, providing minimum percentage of density specified for each area classification indicated below.
2. All compaction requirements for this section are specified on the construction plans.

B. Moisture Control:

1. Where subgrade of layer of soil material must be moisture conditioned before compaction, uniformly apply water to surface of subgrade, or layer of soil material, to prevent free water appearing on surface during subsequent to compaction operations.
2. Remove and replace, or scarify and air dry, soil material that is too wet to permit compaction to specified density.
3. Soil material that has been removed because it is too wet to permit compaction may be stockpiled or spread and allowed to dry. Assist drying by dicing, harrowing or pulverizing, until moisture content is reduced to a satisfactory value.

3.03 BACKFILL AND FILL

A. General: Place acceptable soil material in layers to required subgrade elevations, for each area classification listed below:

1. In excavations, use satisfactory excavated or borrow material.
2. Under grassed areas, use satisfactory excavated or borrow material.
3. Under walks and pavements, use subbase material, or satisfactory excavated or borrow material, or combination of both.

4. Under piping and conduit, use subbase material where subbase is indicated under piping or conduit; shape to fit bottom 90 degrees of cylinder.
- B. Backfill excavation as promptly as work permits, but not until completion of the following;
1. Acceptance of construction below finish grade.
 2. Inspection, testing, approval, and recording locations of underground utilities.
 3. Removal of concrete formwork.
 4. Removal of shoring and bracing, and backfilling of voids with satisfactory materials. Cut off temporary sheet piling driven below bottom of structures and remove in manner to prevent settlement of the structure or utilities, or leave in place if required.
 5. Removal of trash and debris.
 6. Permanent or temporary horizontal bracing is in place on horizontally supported walls.
- C. Ground Surface Preparation:
1. Remove vegetation, debris, unsatisfactory soil materials, obstructions, and deleterious materials from ground surface prior to placement of fills. Plow, strip, or break-up sloped surfaces steeper than 1 vertical to 4 horizontal so that fill material will bond with existing surface.
 2. When existing ground surface has a density less than that specified under "Compaction" for particular area classification, break-up ground surface, pulverize, moisture-condition to optimum moisture content, and compact to required depth and percentage of maximum density.
- D. Placement and Compaction:
1. The lower portion of backfill, to a compacted level of one foot above the top of the pipe, shall be hand placed in layers of lifts not to exceed six inches of compacted depth and each layer compacted individually by means of hand tampers. Above that level, place lifts in layers not to exceed twelve inches of compacted depth and machine filling and tamping may be used.
 2. Before compaction, moisten or aerate each layer as necessary to provide optimum moisture content. Compact each lift to required percentage of minimum soil density for each area classification as designated herein. Do not place backfill or fill material on surfaces that are muddy, frozen, or contain frost or ice.

3. Place backfill and fill materials evenly adjacent to structures, piping or conduit to required elevations. Take care to prevent wedging action of backfill against structures or displacement of piping or conduit by carrying material uniformly around structure, piping or conduit to approximately same elevation in each lift.

3.04 GRADING

A. General:

1. Uniformly grade areas within limits of grading under this section, including adjacent transition areas.
2. Smooth finished surfaces within specified tolerances, compact with uniform levels or slopes between points where elevations are indicated, or between such points and existing grades.

B. Grading Outside Building Lines:

1. Grade areas adjacent to building lines to drain away from structures and to prevent ponding.

C. Finish surfaces free from irregular surface changes, and as follows:

1. Lawn or Unpaved Areas: Finish areas to receive topsoil to within not more than 0.10' above or below required subgrade elevations.
2. Walks: Shape surface of areas under walks to line, grade and cross-section, with finish surface not more than 0.10' above or below required subgrade elevation.
3. Pavements: Shape surface of areas under pavement to line, grade and cross-section, with finish surface not more than 1/2" above or below required subgrade elevations.

D. Grading Surface of Fill Under Building Slabs:

1. Grade smooth and even, free from voids, compacted as specified, and to required elevation.
2. Provide final grades within a tolerance of 1/2" when tested with a 10' straightedge.
3. Compaction: After grading, compact subgrade surfaces to the depth and indicated percentage for each area classification.

3.05 FIELD QUALITY CONTROL

- A. Quality Control Testing During Construction:
 - 1. Provide testing service by a qualified soil testing firm, subject to ENGINEER's approval, to inspect and approve subgrades and fill layers before further construction work is performed.
- B. Paved Areas:
 - 1. Make at least one field density test of subgrade for every 2000 square feet of paved area but in no case less than 3 tests, nor less than 1 per driveway or crossing. In each compacted fill layer, make one field density test for every 2,000 square feet of paved area but in no case less than 3 tests, nor less than 1 per driveway or crossing.
- C. Non-Paved Areas:
 - 1. Perform at least 1 field density test per 3,000 square feet of fill per every vertical foot of height, and perform at least 1 field density test per 1,000 feet of pipe installed per every 2 feet of vertical trench depth.
- D. If in opinion of ENGINEER, based on testing service reports and inspection, subgrade or fills which have been placed below are specified density, provide additional compaction and testing at no additional expense.

3.06 MAINTENANCE

- A. Protection of Graded Areas:
 - 1. Protect newly graded areas from traffic and erosion. Keep free of trash and debris.
- B. Repair and re-establish grades in settled, eroded, and rutted areas to specified tolerances.
- C. Reconditioning Compacted Areas:
 - 1. Where completed compacted areas are disturbed by subsequent construction operations or adverse weather, scarify surface, re-shape, and compact to required density prior to further construction.
- D. Grassed Areas:
 - 1. See Section 02210, "Grassing" for requirements of grassed areas.

3.07 DISPOSAL OF EXCESS AND WASTE MATERIALS

CITY OF CALLAWAY CHERRY STREET DIRECTIONAL BORE

- A. Disposal of all spoil material resulting from construction shall be the responsibility of the CONTRACTOR.

END OF SECTION

**SECTION 02210
GRASSING**

PART 1 - GENERAL

1.01 RELATED DOCUMENTS

- A. Drawings and general provisions of Contract, including General and Special Conditions, apply to work of this section.

1.02 DESCRIPTION OF WORK

- A. Extent of grassing work is as specified or shown on the construction plans. All other areas disturbed during construction operations shall be seeded.

1.03 QUALITY ASSURANCE

- A. All seed used shall be labeled in accordance with U. S. Department of Agriculture Rules and Regulations under the Federal Seed Act in effect on the date of invitation for bids. All seed shall be furnished in sealed standard containers, unless exception is granted in writing by Owner. Seed which has become wet, moldy, or otherwise damaged in transit or in storage shall not be used. Fertilizer shall be delivered to the site in the original, unopened containers, each bearing the manufacturer's guaranteed analysis. Any fertilizer which becomes caked or otherwise damaged, making it unsuitable for use, shall not be used. Seed, fertilizer and other grassing materials shall be stored under cover and protected from damage which would make them unacceptable for use.

1.04 SUBMITTALS

- A. Approvals, except those required for field installations, field applications, and field tests shall be obtained before delivery of materials or equipment to the project. The results of laboratory tests performed on the topsoil material shall be submitted. The reports shall include the pH level, the amount of organic matter, and available phosphoric acid and potash of the soil intended for use in the work. Certificate of conformance will be required for the following:
 - 1. Grass seed shall be certified by registered, certified seed association or a registered testing laboratory not more than ten months prior to seeding.
 - 2. Sprigs
 - 3. Fertilizer
 - 4. Topsoil
 - 5. Lime
 - 6. Mulching

PART 2 - PRODUCTS

2.01 TOPSOIL

- A. If the quantity of existing stored or excavated topsoil is inadequate for planting, sufficient additional topsoil shall be furnished. Topsoil furnished shall be a natural, fertile, friable soil, possessing characteristics of representative productive soils in the vicinity. It shall be obtained from naturally well-drained areas. Topsoil shall be without admixture of subsoil and free from johnson grass (*Sorghum halepense*), nut grass (*Cyperus rotundus*) and objectionable weeds and toxic substances.

2.02 SOIL AMENDMENTS

- A. Lime: Ground Limestone (Dolomite) containing not less than 85 percent of total carbonates, and shall be ground to such a fineness that 50 percent will pass a 100-mesh sieve and 90 percent will pass a 20-mesh sieve.
- B. Fertilizer: 16-16-16 formulation of which 60 percent of the nitrogen is in the urea-formaldehyde form and shall conform to the applicable State Fertilizer laws. It shall be granulated so that 80 percent is held on a 16-mesh screen, uniform in composition, dry and free-flowing.
- C. Mulch: Clean hay or fresh straw.

2.03 GRASS MATERIALS

- A. Grass Seed: Federal Specifications JJJ-S-181 and shall satisfy the following requirements:

Seed	Min. % Pure Seed	Min.% Germination and Hard Seed	Max.% Weed Seed
Bermuda Grass, (Cynodon Dactylan)	80%	15%	.25%

- B. Seed failing to meet the purity or germination requirements by no more than twenty-five percent may be used, but the quantity shall be increased to yield the required rate of pure live seed. Seed failing to meet the weed seed requirements shall not be used.

PART 3 - EXECUTION

3.01 GRADING

- A. Areas to be grassed shall be graded to remove depressions, undulations, and irregularities in the surface before grassing.

3.02 PLACING TOPSOIL

- A. Areas to be grassed shall have a minimum topsoil cover of two inches. Topsoil shall not be placed when the subgrade is excessively wet, extremely dry or in a condition otherwise detrimental to the proposed planting or proper grading.

3.03 TILLAGE

- A. The area to be grassed shall be thoroughly tilled to a depth of four inches using a plow and disc harrow or rotary tilling machinery until a suitable bed has been prepared and no clods or clumps remain larger than 1-1/2 inches in diameter.

3.04 APPLICATION OF LIME

- A. The pH of the soil shall be determined. If the pH is below 5.0, sufficient lime shall be added to provide a pH between 5.5 and 6.5. The lime shall be thoroughly incorporated into the top three to four inches of the soil. Lime and fertilizer may be applied in one operation.

3.05 APPLICATION OF FERTILIZER

- A. Fertilizer shall be applied at the rate of 6 pounds per 1,000 square feet and shall be thoroughly incorporated into the top three to four inches of soil.

3.06 PLANTING SOIL

- A. All areas disturbed during construction shall be seeded as specified herein. Immediately before seeds are sown and after fertilizer and lime are applied, the ground shall be scarified as necessary and shall be raked until the surface is smooth, friable, and of uniformly fine texture. Areas to be grassed shall be seeded evenly with a mechanical spreader, raked lightly, rolled with a 200-pound roller, and watered with a fine spray.

- 1. Seed shall be applied at the following rate:

<u>Seed</u>	<u>Rate of Application</u>
Bermuda Grass, (Cynodon Dactylan)	6 lbs./1000 sq. ft. 260 lbs./acre

CITY OF CALLAWAY CHERRY STREET DIRECTIONAL BORE

2. Seeded areas shall be mulched at the rate of not less than 1-1/2" loose measurement over all seeded areas. Spread by hand, blower, or other suitable equipment. Mulch shall be cut into the soil with equipment capable of cutting the mulch uniformly into the soil. Mulching shall be done within 24 hours of the time seeding is completed. All seeded areas shall be mulched, no exceptions. Hydro-seed must also be mulched.

3.07 ROLLING

- A. After seeding and mulching, a cultipacker, traffic roller, or other suitable equipment shall be used for rolling the grassed areas. Areas shall then be watered with a fine spray.

3.08 WINTER COVER

- A. All areas to be grassed shall be protected against erosion at all times. For protection during winter months (November 1st through March 31st) Italian rye grass shall be planted at the rate of four pounds per 1,000 square feet on all areas which are not protected by permanent grass. This does not alleviate the contractor from the required seeding.

3.09 CLEAN-UP

- A. All excess soil, excess grass materials, stones, and other waste shall be removed from the site daily and not allowed to accumulate.

3.10 MAINTENANCE

- A. Maintenance shall begin immediately following the last operation of grassing and continue until final acceptance. Maintenance shall include watering, mowing, replanting, and all other work necessary to produce a uniform stand of grass. Grassing will be considered for final acceptance when the permanent grass is healthy and growing on 97 percent of the area with no bare areas wider than 12 inches.

3.11 ACCEPTANCE

- A. The Contractor shall submit to the Owner two copies of a written request for final acceptance of the grassing work. The request shall be submitted at least ten days prior to the anticipated date of acceptance. The condition of the grass will be noted, the Contractor will be notified if maintenance is to continue.

END OF SECTION

**SECTION 02211
SODDING**

PART 1 - GENERAL

1.01 WORK INCLUDED

- A. Sod Installation

1.02 REFERENCES

- A. ASPA - American Sod Producers Association - Guideline Specifications to Sodding.
- B. FS O-F-241 - Fertilizers, Mixed, Commercial.

1.03 DEFINITIONS

- A. Weeds: Dandelion, Jimsonweed, Quackgrass, Horsetail, Morning Glory, Rush Grass, Mustard, Lambsquarter, Chickweed, Cress, Crabgrass, Canadian Thistle, Nutgrass, Poison Oak, Blackberry, Tansy Ragwort, Bermuda Grass, Johnson Grass, Poison Ivy, Nut Sedge, Nimble Hill, Bindweed, Bent Grass, Wild Garlic, Perennial Sorrel, and Brome Grass.

1.04 DELIVERY, STORAGE, AND HANDLING

- A. Deliver sod on pallets. Protect exposed roots from dehydration.
- B. Do not deliver more sod that can be laid within 24 hours.

PART 2 - PRODUCTS

2.01 ACCEPTABLE SOD GROWERS

- A. Nurseries and Sod Growers in the surrounding area who have a five year record are acceptable.

2.02 MATERIALS

- A. Sod:
 - 1. ASPA approved, field grown grade; cultivated grass sod; for low maintenance and traffic durability, with strong fibrous root system, free of stone, burned or bare spots; containing no more than 5 weeds per 1000 square feet.

- B. Approved Sods:
 - 1. Bermuda, (Cynodon Dactylon).

2.03 HARVESTING SOD

- A. Machine cut sod and load on pallets in accordance with ASPA guidelines.
- B. Cut sod in area not exceeding one square yard, with minimum 1/2 inch and maximum one inch topsoil base.

PART 3 - EXECUTION

3.01 INSPECTION

- A. Verify that prepared soil base is ready to receive the work of this Section.
- B. Beginning of installation means acceptance of existing site conditions.

3.02 PREPARATION OF SUBSOIL

- A. Prepare subsoil to eliminate uneven areas and low spots. Maintain lines, levels, profiles and contours. Make changes in grade gradual. Blend slopes into level areas.
- B. Remove foreign materials and undesirable plants and their roots. Do not bury foreign material beneath areas to be sodded. Remove contaminated subsoil.

3.03 LAYING SOD

- A. Moisten prepared surface immediately prior to laying sod.
- B. Lay sod immediately on delivery to site and within 24 hours after harvesting to prevent deterioration.
- C. Lay sod tight with no open joints visible, and no overlapping; stagger end joints 12-inches overlapping; minimum. Do not stretch or overlap sod pieces.
- D. Lay smooth. Align with adjoining grass areas. Place top elevation of sod 1/2 inch below adjoining paving or curbs.
- E. On slopes 6 inches per foot and steeper, lay sod perpendicular to slope and secure every row with wooden pegs at maximum 2 feet on center. Drive pegs flush with soil portion of sod.
- F. Prior to placing sod, on slopes exceeding 8 inches per foot or where indicated, place wire mesh over topsoil. Securely anchor in place with wood pegs sunk firmly into the ground.

CITY OF CALLAWAY CHERRY STREET DIRECTIONAL BORE

- G. Water sodded areas immediately after installation. Saturate sod to 4 inches of soil.
- H. After sod and soil have dried, roll sodded areas to ensure good bond between sod and soil and to remove minor depressions and irregularities.
- I. Sod shall be laid in all ditch areas and slopes that are equal to or steeper than 1 vertical to 3 horizontal or in areas determined by the Engineer to "erosion problem" areas. Sod shall be pinned down for stabilization in these areas.

END OF SECTION

**SECTION 02222
TRENCHING, BACKFILLING AND COMPACTING**

PART 1 - GENERAL

1.01 DESCRIPTION OF WORK

- A. The extent of trenching, backfilling and compacting is shown on the drawings.
- B. This section includes furnishing equipment, labor and materials, and performing all operations necessary and incidental to perform the required work.

PART 2 – PRODUCTS NOT USED

PART 3 - EXECUTION

3.01 CLEARING THE SITE

- A. The site of the work shall be cleared of all trees, shrubs, paving and objectionable material which interfere with the prosecution of the proposed work. Trees and shrubs which will not interfere with construction shall be protected from damage. Clearing shall be considered as an incidental item of excavation.

3.02 EXCAVATION

- A. General:
 - 1. Perform excavation described of whatever substance encountered to the dimensions and depths specified or shown on the drawings.
 - 2. Undercutting will not be permitted, except when ordered by the ENGINEER. Material suitable for backfill shall be stockpiled near the site.
 - 3. Rock or other material undesirable for backfill shall be spoiled outside the area in a neat manner, as directed by the ENGINEER.
 - 4. Where it is necessary to cut roots projecting into an excavation or where it is necessary to trim branches for equipment clearance, all severed root ends or cuts to branches over 1/2-inch diameter shall be treated with an asphalt base pruning paint.
 - 5. Backfill over exposed roots as soon as possible.

B. Rock:

1. Where encountered in the trench bed, rock shall be excavated to a depth of 1/4 of the pipe diameter below the bottom of the pipe but in no case less than 4-inches.
2. All undercut trench excavation shall be backfilled and tamped with materials as specified in the following paragraphs under Unstable Subgrade.

C. Unstable Subgrade:

1. In the event that unsuitable material is encountered at or below the excavation depth specified or shown on the drawings, the ENGINEER shall be notified.
2. Such material shall be removed and replaced with suitable material. Methods and materials used for replacement shall be one of the following as directed by the ENGINEER in writing.
 - a. Suitable earth or sand, compacted in the trench. Materials shall be furnished as a part of the Bid Proposal item covering excavation and backfill.
 - b. Gravel or crushed limerock, compacted in the trench and paid for under the appropriate item.
 - c. Existing materials, stabilized after removal and then replaced and compacted in the trench at no additional cost to the OWNER.
2. The Engineer shall determine the methods and materials to be used, based upon the condition of the excavation, the pipe structure to be supported, and the availability and character of stabilizing materials.

D. Trenches:

1. Keep pipe laying operation as close to the excavation operation as possible during the prosecution of the work. The ENGINEER reserves the right to stop the excavation at any time when, in his opinion, the excavation is opened too far in advance of the pipe laying.
2. Pipe trenches shall be excavated to a depth that will insure a minimum of 36-inches of cover for ductile iron and PVC pipe and 54-inches of cover for polyethylene pipe, except service laterals.

CITY OF CALLAWAY CHERRY STREET DIRECTIONAL BORE

- a. Trenches shall be only of sufficient width to provide a free working space on each side of the pipe.
 - b. To prevent excess pressure on the pipe, the maximum width of trench at the top of the pipe and at the bottom of the trench shall not be greater than 2-feet more than the greatest exterior diameter of the pipe.
 - c. If this maximum width is exceeded, it shall be the CONTRACTOR's responsibility to provide, at no additional cost to the OWNER, such additional bedding or select backfill materials as the ENGINEER may require.
 - d. The excavation below the spring line shall be made to conform as near as possible to the shape of the lower third of the pipe.
 - e. To protect the pipe lines from unusual stresses, all work shall be done in open trenches.
 - f. Excavation shall be made for bells of all pipes and of sufficient depth to permit access to the joint for construction and inspections. In no case will the bells be used to support the body of the pipe.
3. In order to avoid existing utilities, at times it may be necessary for the pipe to be laid deeper than the minimum cover specified in the preceding paragraph. At such time the CONTRACTOR will not be allowed extra compensation for additional excavation involved.
 4. In case excavation has been made deeper than necessary, a layer of concrete, fine gravel or other material satisfactory to the ENGINEER shall be placed, at no extra cost, to secure a firm foundation for the lower third of each pipe.
 - a. Where possible, excavated material shall be placed so as not to interfere with public travel.
 - b. Bridging shall be provided to afford necessary access to public or private premises.
 - c. Bridging shall be considered as part of the excavation operation and shall be supplied at no additional cost to the OWNER.

E. Structural: (For inlets, manholes, valve pits and similar structures)

1. Remove sufficient material to allow proper space for erecting and removing forms. The elevations of the bottoms of footings, if shown on the drawings, shall be considered as approximate only, and the ENGINEER may order, in writing, such changes in dimensions or elevations of footings as may be deemed necessary to secure a satisfactory foundation. Excavation for structures shall be sufficient to leave at least 12-inches in the clear between their outer surfaces and the embankment of timber that may be used to protect them. Backfill of earth under structures will not be permitted. Excess excavation for structures shall be filled with thoroughly compacted sand, gravel, or concrete at the expense of the CONTRACTOR.
2. After excavation for a structure is completed, the CONTRACTOR shall notify the ENGINEER to that effect. No concrete or reinforcing steel shall be placed until the ENGINEER has approved the depth of the excavation and the character of the foundation material.

F. Sheeting and Shoring:

1. The CONTRACTOR shall provide all trench and structural bracing, sheeting or shoring necessary to construct and protect the excavation, existing utilities, structures and private property of all types and as required for the safety of the employees. Sheeting shall be removed or cut off by the CONTRACTOR during backfilling operations as directed by the ENGINEER. Sheeting which is left in place by order of the ENGINEER will be paid for under the item, Lumber left in Place. Removal of shoring for structures shall be done in such a manner as not to disturb or mar finished masonry or concrete surfaces.

3.03 DRAINAGE

- A. Grading shall be controlled in the vicinity of excavations so that the surface of the ground will be properly sloped to prevent water from running into trenches or other excavated areas. Any water which accumulates in the excavations shall be removed promptly by well point or by other means satisfactory to the ENGINEER in such a manner as to not create a nuisance to adjacent property or public thoroughfare. Trenches shall be kept dry while pipe is being laid. Bridging of dewatering pipe shall be provided where necessary. Pumps and engines for well point systems shall be operated with mufflers, and at a minimum noise level suitable to a residential area. The CONTRACTOR will not be allowed to discharge water into the OWNER's storm drainage system without the written approval of the ENGINEER. Approval will be subject to the condition that the storm sewer be returned to its original condition.

- B. The CONTRACTOR is responsible for carrying the water to the nearest ditch or body of water and for obtaining the necessary permission to use same. The CONTRACTOR shall be financially responsible for any nuisance created due to carrying off water from his drainage system.

3.04 BACKFILL

A. Trenches:

1. Trenches shall be backfilled immediately after the pipe is laid unless other protection for the pipeline is provided. Clean earth, sand, crushed limerock or other material approved by the ENGINEER shall be used for backfill. Backfill material shall be selected, deposited and compacted (simultaneously on both sides of the pipe) so as to eliminate the possibility of lateral displacement of the pipe. Backfill material shall solidly tamped around the pipes in layers to a level at least 1-foot above the top of the pipe. Each layer shall be compacted to a maximum thickness of 6-inches.
2. In unpaved areas, the remainder of the backfill shall be deposited and then compacted by puddling, water flooding or mechanical tampers. Mechanical tamping of layers in unpaved areas shall be to a maximum thickness of 12-inches. In areas to be paved or repaved, the entire depth of backfill shall be deposited in layers and compacted by hand or mechanical tampers to a maximum thickness of 6-inches. Compaction shall be carried out to achieve a density of at least 98% of the maximum density as determined by AASHTO, Method T-180. Under areas to be paved, puddling may be used for backfill consolidation after tamping to 1-foot over the pipe, as specified, provided the method is first approved by the ENGINEER and the density requirements are met.
3. In areas to be paved, density tests for determination of the specified compaction shall be made by a testing laboratory and spaced one in every 300-feet of trench cut. It is the intent of this specification to secure a condition where no further settlement of trenches will occur. When backfilling is completed, the roadway base for pavement replacement may be placed immediately. It will be the responsibility of the CONTRACTOR to restore the surface to the original grade wherever settlement occurs.

B. Wet Trenches (CONTRACTOR's Option):

1. Backfill for the pipe bed in wet trenches shall be crushed, graded limerock, compacted in the trench. After the pipe is laid, a graded limerock backfill shall be placed and worked in around the haunches to a point 6-inches above the pipe. The width of the limerock material around the pipe shall not be less than the outside diameter of the pipe plus 6-inches on each side of the pipe. Material shall be carefully distributed along the pipe so as to provide full and uniform support under and around the pipe. Six inches above the top of the pipe and up to the water level, material from the excavations with no rock or earth exceeding 4-inches in any one dimension shall then be lifted to the trench and released at the water level. Material shall be uniformly distributed for the full width of the trench. Backfill and compaction above the water level in the trench shall be as specified above. All costs for graded limerock placed in wet trenches shall be included in the cost of stage excavation and backfill for the various sizes of pipe.

C. Bedding and Backfill - Flexible Pipe:

1. For polyvinyl chloride pipe, the bedding and backfill materials shall be such as to limit the vertical ring deflection to 5% of the inside pipe diameter. A deflection greater than 5% of the inside diameter shall be cause for rejection of the pipe.
2. Class IV or Class V materials as defined in ASTM D2321-74 shall not be used for bedding, haunching or initial backfill for flexible pipes.
3. For polyvinyl chloride plastic pipe, bedding shall be in accordance with ASTM D2321-74, using Class I, II or III materials, except under wet conditions. In any area where the pipe will be installed below existing or future groundwater levels or where the trench could be subject to inundation, Class I material shall be placed to the springline of the pipe.
4. A minimum of effort is needed to compact the material. However, in the initial stage of placing this type of material, take care to ensure that sufficient material has been worked under the haunch of the pipe to provide adequate side support. Take precautions to prevent movement of the pipe during placing of the material under the pipe haunch. Except for the protection of the pipe from large particles of backfill material, little care need be taken and no compaction is necessary in placing backfill material in the balance of the initial backfill area above the pipe. Where unstable trench wall exist because of migratory materials, such as water-bearing silts or fine sand, take care to prevent the loss of side support through the migratory action.

5. All bedding requirements for flexible pipe specified in the preceding paragraphs shall be included in the price bid for the applicable pipe material and no additional compensation for bedding material will be allowed.

D. Structural:

1. After completion of foundation footings and walls and other construction below the elevation of the final grades, and prior to backfilling, forms shall be removed and the excavation shall be cleared of all trash and debris.
2. Material for backfilling shall consist of the excavation, borrow sand or other approved materials, and shall be free of trash, lumber or other debris.
3. Backfill shall be placed in horizontal layers not in excess of 9-inches in thickness, and have a moisture content such that a density may be obtained to prevent excessive settlement or shrinkage.
4. Each layer shall be compacted by hand or approved machine tampers with extreme care being exerted not to damage pipe or structures.
5. Backfill shall be placed and compacted evenly against the exposed surfaces to prevent undue stress on any surface.

3.05 RESTORATION OF SURFACE IMPROVEMENTS

- A. Roadways, including shoulders, alleys and driveways of shell, limerock, stabilized soil or gravel, grass plots, sod, shrubbery, ornamental trees, signs, fences, or other surface improvements on public or private property which have been damaged or removed in excavation, shall be restored to conditions equal to or better than conditions existing prior to beginning work.

1. Restoration of shoulders shall consist of seeding and mulching or stabilizing with limerock as selected by the ENGINEER.
2. The cost of doing this work shall be included in the cost of the various applicable items.
3. General Quality Control will be used as an aid in determining conditions prior to construction.

- B. Materials for unpaved roadways, road shoulders, alleys, or driveways, shall be compacted as described in the plans. The cost of this work and furnishing new materials shall be included in the cost of the applicable items of work as no

separate payment will be made, unless a separate bid item is provided.

3.06 FINE GRADING

- A. Finished areas around structures shall be graded smooth and hand raked and shall meet the elevations and contours shown on the drawings. Lumber, earth clods, rocks and other undesirable materials shall be removed from the site.

3.07 DISPOSAL OF MATERIALS

- A. Such portions of the excavated materials as needed and as suitable, shall be used for backfilling and grading about the completed work to the elevations as shown of the drawings or as directed. Excavated material in excess of the quantity required for this purpose shall be disposed of by the CONTRACTOR in those areas designated by the OWNER and as shown on the drawings. The CONTRACTOR shall leave the earth over the trenches or other excavations in a neat and uniform condition acceptable to the OWNER.

3.08 PAVEMENT REPLACEMENT

- A. Asphalt pavement shall be removed by saw cutting on a straight line with edges as vertical as possible. Concrete pavement or asphalt surfaced concrete shall be removed by cutting with a concrete saw in as straight a line and vertically as possible. Materials to replace State Highway paving shall conform to the specifications required by the Florida Department of Transportation Specifications for Type S-I asphaltic concrete surface course, or as specifically shown in the plans.
- B. Prior to replacing concrete or asphalt pavement replacement, a limerock base shall be laid. The base for concrete pavement shall be 6-inches of compacted thickness, and that for asphalt pavement shall be 8-inches of compacted thickness. The base course for each shall be compacted to a minimum of 98% of the maximum density as determined by AASHTO, Method T-180. The OWNER will have tests made by an independent testing laboratory to verify compaction results. One test will be made for each block of continuous trench cut.
- C. Non-asphalt pavement replacement shall be replaced of like material and thickness. Asphalt or built-up asphalt pavement shall be replaced with like material or concrete as directed by the ENGINEER. Where asphalt or built-up asphalt pavement is replaced by concrete, the concrete shall have a minimum of 6-inches in thickness and be reinforced with 6 by 6 no. 6 gage welded wire fabric. Concrete for paving shall be 3,000 psi design strength. Where the pavement replacement is of like material, it shall be replaced in thickness equal to or better than that existing at the time of removal.
- D. Unless the base is sealed or other temporary paving applied over areas to be repaved, pavement shall be replaced not later than 3-weeks after completion of

backfill.

3.09 TESTS

- A. The CONTRACTOR shall furnish facilities for making all density tests and make such restorations as may be necessary due to test operations. All density tests on backfill or base replacement will be made by a commercial testing laboratory employed by the CONTRACTOR and at such locations as may be recommended by the ENGINEER. If the densities as determined by the specified tests fall below the required minimums, the CONTRACTOR shall pay for all retests.

3.10 SIDEWALK, CURB AND GUTTER REMOVAL AND REPLACEMENT

- A. Sidewalk, curb and gutter removal and replacement required in the construction of this work shall be done by the CONTRACTOR. Reasonable care shall be exercised in removing sidewalk and curb and gutter, and the CONTRACTOR shall either stockpile or dispose of this material as directed by the ENGINEER. Brick, concrete or built-up asphalt sidewalk replacement and curb and gutter replacement shall be replaced of like material in a manner and condition equal to or better than that existing at the time of removal. Materials and methods of replacing State Highway sidewalks or curbs shall conform to the Department of Transportation specifications.

END OF SECTION

**SECTION 02960
RESTORATION**

PART 1 - GENERAL

1.01 DESCRIPTION OF WORK

- A. The work includes the restoration of driveways, lawn areas, trees and plants, roadways, sprinkler systems, walks and any other existing improvement affected by the proposed work.
- B. This section includes furnishing equipment, labor and materials, and performing all necessary and incidental operations to perform the required work.

PART 2 - PRODUCTS

2.01 SOD

- A. Any slope equal to or steeper than 1 vertical to 3 horizontal shall be sodded and the sod shall be pinned down for stabilization.
- B. The CONTRACTOR shall, at his expense, maintain the sodded areas in a satisfactory condition until final acceptance of the project. Such maintenance shall include watering, re-staking sod, filling, leveling and repairing of any washed or eroded areas, as may be necessary.

2.02 PLANTS AND TREES

- A. Existing damaged plants and trees shall be replaced by plants and trees of equal type, quality and size whenever possible. All new plants and trees shall be sound, healthy, vigorous and free from defects, decay, disfiguring, bark abrasions, plant diseases, insect pests, their eggs or larvae. The new plants shall be approved by the ENGINEER before placing.
- B. Existing plants may be removed, preserved, and replaced at the CONTRACTOR'S option. Plants shall be handled by an approved nursery.
- C. Plants shall be watered and cared for until new growth appears. Dead and dying plants shall be immediately replaced. Plants used shall be in accordance with the standards for Florida No. 1 or better as given in Grades and Standards for Nursery Plants Part 1.
- D. Plants shall conform to the sizes indicated by the OWNER.

- E. Trees shall be guaranteed for one year. If the replaced tree dies within one year of project completion it shall be replaced by the CONTRACTOR at no expense to the City.

2.03 MULCH

- A. Match existing mulch.

2.04 WATER

- A. The water used in the performance of this Contract shall be of drinking water quality, clean and free from injurious amounts of oil, acid, alkali, or organic matter. The CONTRACTOR shall purchase all testing water from the County.

2.05 PLANTING MIXTURE:

- A. The 18 inch planting mixture, when required, shall consist of a thorough mixture of 40% peat and 60% sand. The peat shall be Florihome peat or equivalent and the sand shall be clean and free from debris of any kind.

2.06 FERTILIZER

- A. Fertilizer shall be pelletized 13-13-13, or approved equal.

PART 3 - EXECUTION

3.01 LANDSCAPING RESTORATION

- A. Lawn Areas: Any lawn area affected by the required work shall be restored to a condition equal or better than the conditions existing before the commencement of work.
- B. Balled Plants: Plants where required shall be adequately balled with firm natural balls of soil, sized as set forth in "Horticultural Standards." Balls shall be firmly wrapped with burlap or equally approved strong cloth. No balled plant will be planted if the ball is cracked or broken before or during the process of planting.
- C. Preparation of Plant Pits: All plant pits shall be circular in outline and have vertical sides. Tree pits shall be two feet wider than the width of the ball and one foot deeper than the depth of the ball. Shrubs that are either B&B or 3 gallons + shall have pits that are two feet wider than the width of the plant ball and 6 inches deeper than the depth of the ball. Smaller shrubs shall have pits that are at least one foot wider than the width of the plant ball and 6 inches deeper than the ball depth.

- D. Setting Plants: All plants except as otherwise specified, shall be centered in pits. Deep planting shall be avoided and unless otherwise specified, plants shall be set at such a level that after settlement they will bear the same relation to the required grade as they have to the natural grade before being transplanted.
- E. Balled and burlapped plants and palm trees shall be placed on 6 inch to 12 inch of tamped planting mixture and adjusted so as to be at the proper level. The rope and burlap shall be cut away and the burlap folded down to the bottom of the pit. Very large B&B plants shall remain wrapped until fully backfilled and then just the upper portion of the burlap shall be removed. Backfill of planting mix shall be placed halfway up the pit and then water tamped. After this water has drained away, backfill around the ball to grade and water tamp again. Finally, form a ridge of soil around the edge of the pit to form a saucer and full area three times with water.
- F. Water: Water to be used initially during plant installation shall be furnished by the CONTRACTOR. The existing irrigation system, where damaged, shall be promptly repaired after the installation of the plants.
- G. Options as to Methods: Any plant may be furnished container grown instead of balled if all other requirements are met.
- H. Immediately before sod is placed, 8-8-8 fertilizer shall be applied at the rate of approximately 500 pounds per acre, by broadcasting and raking into the planting area.
- I. Sod shall be firmly embedded by light tamping. Wherever necessary to prevent an erosion condition caused by vertical edges at the outer limits of the sodded area, the sod shall be tamped so as to produce a featheredge at the outer limits. The sod shall be kept in a moist condition after it is planted. Water shall not be applied between the hours of 8 A.M., and 4 P.M., nor when there is danger of freezing.
- J. The CONTRACTOR shall, at his expense, maintain the planted areas in a satisfactory condition until final acceptance of the project. Such maintenance shall include watering, filling, leveling and repairing of any washed or eroded areas, as may be necessary.

3.02 PAVEMENT REPLACEMENT

- A. Asphalt pavement shall be removed by saw cutting on a straight line with edges as vertical as possible. Concrete pavement or asphalt surfaced concrete shall be removed by cutting with a concrete saw in as straight a line and vertically as possible.

- B. Non-asphalt pavement replacement shall be replaced of like material and thickness. Asphalt or built-up asphalt pavement replacement shall be replaced with like material or concrete as directed by the ENGINEER.

Where asphalt or built-up asphalt pavement is replaced by concrete, the concrete shall have a minimum of 6 inches in thickness and be reinforced with 6 by 6 No. 6 gage welded wire fabric. Where the pavement replacement is of like material, it shall be replaced in thickness equal to or better than that existing at the time of removal.

- C. Road cuts across City or County roads shall not be cut.
- D. Unless the base is sealed or other temporary paving applied over driveway areas to be repaved, pavement shall be replaced not later than three weeks after completion of backfill.

3.03 CURB REMOVAL AND REPLACEMENT

- A. Curb removal and replacement required in the construction of this work shall be done by the CONTRACTOR. Reasonable care shall be exercised in removing the curb, and the CONTRACTOR shall either stockpile or dispose of this material as directed by the ENGINEER. Curb shall be replaced of like material in a manner and condition equal to or better than that existing at the time of removal. Materials and methods of replacing State Highway sidewalks or curbs shall conform to the Department of Transportation specifications.

3.04 TESTS

- A. The CONTRACTOR shall furnish facilities for making all density tests and make such restorations as may be necessary due to test operations. All density tests on backfill or base replacement will be made by a commercial testing laboratory employed by the CONTRACTOR at such locations as may be recommended by the ENGINEER. If the densities as determined by the specified tests fall below the required minimums, the CONTRACTOR shall pay for all retests.

END OF SECTION

**SECTION 03310
CONCRETE WORK**

PART 1 - GENERAL

1.01 RELATED DOCUMENTS

- A. Drawings and general provisions of Contract, including General and Special Conditions, apply to work of this section.

1.02 DESCRIPTION OF WORK

- A. Extent of concrete work is shown on Drawings.

1.03 SUBMITTALS

A. Product Data:

- 1. Submit data proprietary materials and items, including reinforcement and forming accessories, admixtures, patching compounds, waterstops, joint systems, curing compounds, dry-shake finish materials, and others as requested by ENGINEER.

B. Shop Drawings, Reinforcement:

- 1. Submit original shop drawings for fabrication, bending, and placement of concrete reinforcement.
- 2. Comply with American Concrete Institute (ACI) 315 "Manual of Standard Practice for Detailing Reinforced Concrete Structures" showing bar schedules, stirrup spacing, diagrams of bent bars, and arrangement of concrete reinforcement.
- 3. Include special reinforcement required for openings through concrete structures.

- C. The ENGINEER's review is for general engineering applications and features only. Design of formwork for structural stability and efficiency is the CONTRACTOR's responsibility.

D. Laboratory Test Reports:

- 1. Submit laboratory test reports for concrete materials and mix design test.

1.04 QUALITY ASSURANCE

A. Codes and Standards:

1. Comply with provisions of following codes, specifications, and standards, except where more stringent requirements are shown or specified:
 - a) ACI 301 "Specifications for Structural Concrete for Buildings."
 - b) ACI 318 "Building Code Requirements for Reinforced Concrete."
 - c) Concrete Reinforcing Steel Institute (CRSI) "Manual of Standard Practice."

B. Concrete Testing Services:

1. A testing laboratory shall be engaged that is acceptable to the ENGINEER to perform material evaluation tests and to design concrete mixes.
2. Materials and installed work may require testing and retesting at anytime during progress of work.
3. Tests, including retesting of rejected materials for installed work, shall be done at the CONTRACTOR's expense.

1.05 PROJECT CONDITIONS

A. Protect Footings Against Freezing:

1. Cover completed work at footing level with sufficient temporary or permanent cover as required to protect footings and adjacent subgrade against the possibility of freezing.
2. Maintain cover for time period as necessary.

B. Protect adjacent finish materials against spatter during concrete placement.

PART 2 - PRODUCTS

2.01 FORM MATERIALS

A. Forms for Exposed Finish Concrete:

1. Plywood, metal, metal-framed plywood faced, or other acceptable panel-type materials, to provide continuous, straight, smooth, exposed surfaces.
2. Furnish in largest practicable sizes to minimize number of joints.

- B. Use plywood complying with U. S. Product Standard PS-1 "B-B (Concrete Form) Plywood," Class I, Exterior Grade or better, mill-oiled and edge-sealed, with each piece bearing legible inspection trademark.
- C. Forms for Unexposed Finish Concrete:
 - 1. Plywood, lumber, metal, or other acceptable material.
 - 2. Provide lumber dressed on at least two edges and one side for tight fit.
- D. Form Coatings:
 - 1. Provide commercial formulation form-coating compounds that will not bond with, stain, nor adversely affect concrete surfaces, and will not impair subsequent treatments of concrete surfaces.
- E. Form Ties:
 - 1. Factory-fabricated, adjustable-length, removable or snap-off metal form ties, designed to prevent form deflection and to prevent spalling concrete upon removal.
 - 2. Provide units which will leave no metal closer than 1 ½ inches to surface.
 - 3. Provide ties which, when removed, will leave holes not larger than 1 inch in diameter in concrete surface.

2.02 REINFORCING MATERIALS

- A. Reinforcing Bars:
 - 1. American Society of Testing and Materials (ASTM) A 615
 - 2. Grade 60.
 - 3. Deformed.
- B. Steel Wire:
 - 1. ASTM A 82
 - 2. Plain.
 - 3. Cold-drawn steel.

CITY OF CALLAWAY CHERRY STREET DIRECTIONAL BORE

- C. Welded Wire Fabric:
 - 1. ASTM A 185.
 - 2. Welded steel wire fabric.
- D. Welded Deformed Steel Wire Fabric:
 - 1. ASTM A 497.
- E. Supports for Reinforcement:
 - 1. Use bolsters, chairs, spacers, and other devices for spacing, supporting, and fastening reinforcing bars and welded wire fabric in place.
 - 2. Use wire bar type supports complying with CRSI specifications.
- F. For slabs-on-grade, use supports with sand plates or horizontal runners where base material will not support chair legs.

2.03 CONCRETE MATERIALS

- A. Portland Concrete:
 - 1. ASTM C 150, Type I.
 - 2. Use one brand of cement throughout project, unless otherwise acceptable to the ENGINEER.
- B. Normal Weight Aggregates:
 - 1. ASTM C 33, and as herein specified.
 - 2. Provide aggregates from a single source for exposed concrete.
 - 3. For exterior exposed surfaces, do not use fine or coarse aggregates containing spalling-causing deleterious substances.
- C. Water:
 - 1. Drinkable.

2.04 RELATED MATERIALS

- A. Polyvinyl Chloride (PVC) Waterstops:
 - 1. Corps of Engineers CRD-C 572.

2. Manufacturer: Subject to compliance with requirements, provide products of one of the following or equal:

- a. AFCO Products.
- b. The Burke Co.
- c. Edoco Technical Products.
- d. Greenstreet Plastic Products.
- e. Harbour Town Products.
- f. W. R. Meadows.
- g. Progress Unlimited.
- h. Schleigel Corp.
- i. Vinylex Corp.

B. Granular Base:

1. Use evenly graded mixture of fine and coarse aggregates to provide, when compacted, a smooth and even surface below slabs on grade.

C. Vapor Retarder:

1. Provide vapor retarder cover over prepared base material where indicated below slabs on grade.

2. Use only materials which are resistant to decay when tested in accordance with ASTM E 154, as follows:

- a. Polyethylene sheet not less than 8 mils thick.
- b. Non-Shrink Grout: CRD-C 621, factory pre-mixed grout.

3. Products: Subject to compliance with requirements, provide one of the following or equal:

a. Metallic:

- 1) "Vibrofoil," A. C. Horn, Inc.
- 2) "Metallic Spec. Grout," The Burke Co.
- 3) "Embeco 636," Master Builders.
- 4) "Ferrolith GDS," Sonneborn-Rexnord.
- 5) "Hi-Mod Grout," Euclid Chemical Co.
- 6) "Kemox G," Sika Chemical Co.
- 7) "Ferrogrout," L & M Const. Chemical Co.
- 8) "Supreme Plus," Gifford-Hill/American Admixtures.

b. Non-Metallic:

- 1) "Set Grout," Master Builders.
- 2) "Sonogrout," Sonneborn-Rexnord.
- 3) "Euco-NS," Euclid Chemical Co.
- 4) "Supreme," Gifford-Hill/American Admixtures.
- 5) "Crystex," L & M Const. Chemical Co.
- 6) "Sure-Grip Grout," Dayton Superior Corp.
- 7) "Horngrout," A. C. Horn, Inc.
- 8) "Five Star Grout," U. S. Grout Corp.

D. Liquid Membrane-Forming Curing Compound:

1. Liquid type membrane-forming curing compound complying with ASTM C 309, Type I, Class A.
2. Moisture loss not more than 0.055 grams per square centimeter (gr./sq. cm.) when applied at 200 square feet per gallon (sq. ft./gal).
3. Products: Subject to compliance with requirements, provide one of the following or equal:
 - a. "Masterseal," Master Builders.
 - b. "A-H 3 Way Sealer," Anti-Hydro Waterproofing Co.
 - c. "Ecocure," Euclid Chemical Co.
 - d. "Clear Seal," A. C. Horn, Inc.
 - e. "Sealco 309," Gifford-Hill/American Admixtures.
 - f. "J-20 Acrylic Cure," Dayton Superior.
 - g. "Spartan-Cote," The Burke Co.
 - h. "Sealkure," Toch Div. – Carboline.
 - i. "Kure-N-Seal," Sonneborn-Rexnord.
 - j. "Polyclear," Upco Chemical/USM Corp.
 - k. "L & M Cure," L & M Construction Chemicals.
 - l. "Klearseal," Setcon Industries.
 - m. "LR-152," Protex Industries.
 - n. "Hardtop," Gifford-Hill.

2.05 PROPORTIONING AND DESIGN OF MIXES

- A. Prepare design mixes for each type and strength of concrete by either laboratory trial batch or field experience methods as specified in ACI 301. If a trial batch method is used, use an independent testing facility acceptable to the ENGINEER for preparing and reporting proposed mix designs. The testing facility shall not be the same as used for field quality control testing.
- B. Submit written reports to Structural Engineer of each proposed mix for each class of concrete at least 15 days prior to start of work. Do not begin concrete production until mixes have been reviewed by the ENGINEER.
- C. Design mixes to provide normal weight concrete with the following properties, as indicated on drawings and schedules:
 - 1. 4,000 pounds per square inch (psi) 28-day compressive strength; W/C ratio, 0.44 maximum (non-air-entrained).
 - 2. 3,000 psi 28-day compressive strength; W/C ratio, 0.58 maximum (non-air-entrained).
 - 3. 2,500 psi 28-day compressive strength; W/C ratio, 0.67 maximum (non-air-entrained).
- D. Lightweight Concrete:
 - 1. Proportion mix as herein specified.
 - 2. Design mix to produce strength and modulus of elasticity as noted on Drawings, with a split-cylinder strength factor (Fct) of not less than 5.5 for 3,000 psi concrete and a dry weight of not less than 95 pounds (lbs) or more than 110 lbs. after 28 days.
 - 3. Limit shrinkage to 0.03 percent at 28 days.
- E. Adjustment to Concrete Mixes:
 - 1. Mix design adjustments may be requested by the CONTRACTOR when characteristics of materials, job conditions, weather, test results, or other circumstances warrant; at no additional cost to the OWNER and as accepted by the ENGINEER.
 - 2. Submit laboratory test data for revised mix design and strength results to the ENGINEER for acceptance before using in work.

- F. Use air-entraining admixture in exterior exposed concrete, unless otherwise indicated. Add air-entraining admixture at Manufacturer's prescribed rate to result in concrete at point of placement having total air content with a tolerance of plus-or-minus 1½ percent within the following limits:
- G. Slump Limits: Proportion and design mixes to result in concrete slump at point of placement as follows:
 - 1. Ramps, slabs, and sloping surfaces: Not more than 3 inches.
 - 2. Reinforced foundation systems: Not less than 1 inch and not more than 3 inches.
 - 3. Concrete containing HRWR admixture (super-plasticizer): Not more than 8 inches after addition of HRWR to site-verified 2 to 3 inches slump concrete.
 - 4. Other concrete: Not less than 1 inch and not more than 4 inches.

2.06 CONCRETE MIXING

- A. Ready-Mix Concrete: Comply with requirements of ASTM C 94, and as herein specified.
- B. During hot weather, or under conditions contributing to rapid setting of concrete, a shorter mixing time than specified in ASTM C 94 may be required.

PART 3 - EXECUTION

3.01 GENERAL

- A. Coordinate the installation of joint materials and vapor retarders with placement of forms and reinforcing steel.

3.02 FORM

- A. Design, erect, support, brace, and maintain formwork to support vertical and lateral, static, and dynamic loads that might be applied until such loads can be supported by concrete structure.
- B. Construct formwork so concrete members and structures are of correct size, shape, alignment, elevation, and position.
- C. Maintain formwork construction tolerances complying with ACI 347.

CITY OF CALLAWAY CHERRY STREET DIRECTIONAL BORE

- D. Design formwork to be readily removable without impact, shock, or damage to cast-in-place concrete surfaces and adjacent materials.
- E. Construct forms to sizes, shapes, lines, and dimensions shown, and to obtain accurate alignment, location, grades, level, and plumb work in finished structures.
- F. Provide for openings, offsets, sinkages, keyways, recesses, moldings, rustications, reglets, chamfers, blocking, screeds, bulkheads, anchorages and inserts, and other features required for this Work.
- G. Use selected materials to obtain required finishes. Solidly butt joints and provide back-up at joints to prevent leakage of cement paste.
- H. Fabricate forms for easy removal without hammering or prying against concrete surfaces.
- I. Provide crush plates or wrecking plates where stripping may damage cast concrete surfaces.
- J. Provide top forms for inclined surfaces where slope is too steep to place concrete with bottom forms only.
- K. Provide Kerf wood inserts for forming keyways, reglets, recesses, and the like, to prevent swelling and for easy removal.
- L. Provide temporary openings where interior area of formwork is inaccessible for cleanout, for inspection before concrete placement, and for placement of concrete.
 - 1. Securely brace temporary openings and set tightly to forms to prevent loss of concrete mortar.
 - 2. Locate temporary openings on forms at inconspicuous locations.
- M. Chamfer exposed corners and edges as indicated, using wood, metal, PVC, or rubber chamfer strips fabricated to produce uniform smooth lines and tight edge joints.
- N. Provisions for Other Trades:
 - 1. Provide openings in concrete formwork to accommodate work of other trades.
 - 2. Determine size and location of openings, recesses, and chases from trades providing such items.
 - 3. Accurately place and securely support items built into forms.
 - 4. Other trades shall provide location and size of openings. The forms for such openings shall be constructed and set in place under this section.

O. Cleaning and Tightening:

1. Thoroughly clean forms and adjacent surfaces to receive concrete.
2. Remove chips, wood, sawdust, dirt, or other debris just before concrete is placed.
3. Retighten forms and bracing after concrete placement is required to eliminate mortar leaks and maintain proper alignment.

3.03 VAPOR RETARDER INSTALLATION

- A. Place vapor retarder sheeting with longest dimension parallel with direction of pour following the completion of leveling and tamping of granular base for slabs on grade.
- B. Lap joints 6 inches and seal with appropriate tape.

3.04 PLACING REINFORCEMENT

- A. Comply with CRSI's recommended practice for "Placing Reinforcing Bars," for details and methods of reinforcement placement and supports, and as herein specified.
- B. Avoid cutting or puncturing vapor retarder during reinforcement placement and concreting operations.
- C. Clean reinforcement of loose rust and mill scale, earth, ice, and other materials which reduce or destroy bond with concrete.
- D. Accurately position, support, and secure reinforcement against displacement by formwork, construction, or concrete placement operations.
- E. Locate and support reinforcing by metal chairs, runners, bolsters, spacers, and hangers, as required.
- F. Place reinforcement to obtain at least minimum coverages for concrete protection.
 1. Arrange, space, and securely tie bars and bar supports to hold reinforcement in position during concrete placement operations.
 2. Set wire ties so ends are directed into concrete, not toward exposed concrete surfaces.
- G. Install welded wire fabric in as long lengths as practicable.
 1. Lap adjoining pieces at least one full mesh and lace splices with wire.
 2. Offset end laps in adjacent widths to prevent continuous laps in either direction.

3.05 JOINTS

A. Construction Joints:

1. Locate and install construction joints as indicated or, if not indicated, locate so as not to impair strength and appearance of the structure, as acceptable to the ENGINEER.
2. Place construction joints perpendicular to main reinforcement.
3. Continue reinforcement across construction joints, except as otherwise indicated.

B. Waterstops:

1. Provide waterstops in construction joints as indicated.
2. Install waterstops to form continuous diaphragm in each joint.
3. Make provisions to support and protect exposed waterstops during progress of work.
4. Fabricate field joints in waterstops in accordance with Manufacturer's printed instructions.

C. Isolation Joints in Slabs-on-Ground:

1. Construct isolation joints in slabs-on-ground at points of contact between slabs-on-ground and vertical surfaces, such as column pedestals, foundation walls, grade beams, and elsewhere as indicated.

3.06 INSTALLATION OF EMBEDDED ITEMS

A. General:

1. Set and build into work anchorage devices and other embedded items required for other work that is attached to, or supported by, cast-in-place concrete.
2. Use setting drawings, diagrams, instructions, and directions provided by suppliers of items to be attached thereto.

3.07 PREPARATION OF FORM SURFACES

- A. Clean re-used forms of concrete matrix residue, repair and patch as required returning forms to acceptable surface condition.

- B. Coat contact surfaces of forms with a form-coating compound before reinforcement is placed.
- C. Thin form-coating compounds only with thinning agent of type, amount, and under conditions of form-coating compound Manufacturer's directions.
- D. Do not allow excess form-coating material to accumulate in forms or to come into contact with in-place concrete surfaces against which fresh concrete will be placed.
- E. Apply in compliance with Manufacturer's instructions.

3.08 CONCRETE PLACEMENT

A. Pre-Placement Inspection:

- 1. Before placing concrete, inspect and complete formwork installation, reinforcing steel, and items to be embedded or cast-in.
- 2. Notify other crafts to permit installation of their work; cooperate with other trades in setting such work.
- 3. Moisten wood forms immediately before placing concrete where form coatings are not used.
- 4. Apply temporary protective covering to lower 2 feet of finished walls adjacent to poured floor slabs and similar conditions, and guard against spattering during placement.

B. General:

- 1. Comply with ACI 304 "Recommended Practice for Measuring, Mixing, Transporting, and Placing Concrete," and as herein specified.
- 2. Deposit concrete continuously or in layers of such thickness that no concrete will be placed on concrete which has sufficiently hardened to cause the formation of seams or planes of weakness. If a section cannot be placed continuously, provide construction joints as herein specified. Deposit concrete as nearly as practicable to its final location to avoid segregation.
- 3. Placing Concrete in Forms:
 - a Deposit concrete in forms in horizontal layers not deeper than 24 inches and in a manner to avoid inclined construction joints.
 - b Where placement consists of several layers, place each layer while the preceding layer is still plastic to avoid cold joints.

c Consolidation of Concrete:

- 1) Consolidate placed concrete by mechanical vibrating equipment supplemented by hand-spading, rodding, or tamping.
- 2) Use equipment and procedures for consolidation of concrete in accordance with ACI 309.
- 3) Do not use vibrators to transport concrete inside forms.
- 4) Insert and withdraw vibrators vertically at uniformly spaced locations not farther than visible effectiveness of machine.
- 5) Place vibrators to rapidly penetrate placed layer and at least 6 inches into preceding layer.
- 6) Do not insert vibrators into lower layers of concrete that have begun to set. At each insertion, limit duration of vibration to time necessary to consolidate concrete and complete embedment of reinforcement and other embedded items without causing segregation of mix.

4. Placing Concrete Slabs:

- a Deposit and consolidate concrete slabs in a continuous operation, within limits of construction joints, until the placing of a panel or section is completed.
- b Consolidate concrete during placing operations so that concrete is thoroughly worked around reinforcement and other embedded items and into corners.
- c Bring slab surfaces to correct level with straightedge and strike off. Use bull floats or darbies to smooth surface; free of humps or hollows.
- d Do not disturb slab surfaces prior to commencement of finishing operations.
- e Maintain reinforcing in proper position during concrete placement operations.

5. Cold Weather Placing:

- a Protect concrete work from physical damage or reduced strength which could be caused by frost, freezing actions, or low temperatures, in compliance with ACI 306 and as herein specified.
- b When air temperature has fallen to or is expected to fall below 40 degrees Fahrenheit (F)/4 degrees Celcius (C), uniformly heat water and aggregates before mixing to obtain a concrete mixture temperature of not less than 50 degrees F (10 degrees C), and not more than 80 Degrees F (27 degrees C) at point of placement.
- c Do not use frozen materials or materials containing ice or snow.
- d Do not place concrete on frozen subgrade or on subgrade containing frozen materials.
- e Do not use calcium chloride, salt, and other materials containing antifreeze agents or chemical accelerators, unless otherwise accepted in mix designs.

6. Hot Weather Placing:

- a When hot weather conditions exist that would seriously impair quality and strength of concrete, place concrete in compliance with ACI 305 and as herein specified.
- b Cool ingredients before mixing to maintain concrete temperature at time of placement below 90 degrees F (32 degrees C).
- c Mixing water may be chilled or chopped ice may be used to control temperature provided water equivalent of ice is calculated to total amount of mixing water.
- d Use of liquid nitrogen to cool concrete is the CONTRACTOR's option.
- e Cover reinforcing steel with water-soaked burlap if it becomes too hot, so that the temperature of the steel does not exceed the ambient air temperature immediately before embedment in concrete.
- f Fog spray forms, reinforcing steel, and subgrade just before concrete is placed.
- g Use water-reducing retarding admixture (Type D) when required by high temperatures, low humidity, or other adverse placing conditions.

3.09 FINISH OF FORMED SURFACES

A. Rough Form Finish:

1. For formed concrete surfaces not exposed-to-view in the finish work or by other construction, unless otherwise indicated.
2. This is the concrete surface having texture imparted by form facing material used, with tie holes and defective areas repaired and patched, and fins and other projections exceeding 1/4 inch in height rubbed down or chipped off.

B. Smooth Form Finish:

1. For formed concrete surfaces exposed-to-view, or that are to be covered with a coating material directly applied to the concrete, or a covering material directly applied to the concrete, such as waterproofing, dampproofing, veneer plaster, painting, or other similar system.
2. This is as-cast concrete surface obtained with selected form facing material, arranged orderly and symmetrically with a minimum of seams.
3. Repair and patch defective areas with fins or other projections completely removed and smoothed.

C. Grout Cleaned Finish:

1. Provide grout cleaned finish to scheduled concrete surfaces which have received smooth form finish treatment.
2. Combine one part Portland cement to 1½ parts fine sand by volume, and mix with water to consistency of thick paint.
3. Use proprietary additives at the CONTRACTOR's option.
4. Blend standard Portland cement and white Portland cement (amounts determined by trial patches) so that final color of dry grout will match adjacent surfaces.
5. Thoroughly wet concrete surfaces and apply grout to coat surfaces and fill small holes.
6. Remove excess grout by scraping and rubbing with clean burlap.
7. Keep damp by fog spray for at least 36 hours after rubbing.

D. Related Unformed Surfaces:

1. Strike-off smooth tops of walls, horizontal offsets, and similar unformed surfaces occurring adjacent to formed surfaces and finish with a texture matching adjacent formed surfaces.
2. Continue final surface treatment of formed surfaces uniformly across adjacent unformed surfaces, unless otherwise indicated.

3.10 MONOLITHIC SLAB FINISHES

A. ASTM E 1155, "Standard Test Method for Determining Floor Flatness and Levelness Using the "F Number System (inch-pound-units)," shall be used for these finishes as follows:

1. Scratch Finish:

- a. Apply scratch finish to monolithic slab surfaces that are to receive concrete floor topping or mortar setting beds for tile, Portland cement terrazzo, and other bonded applied cementitious finish flooring material, and as otherwise indicated.
- b. After placing slabs, plane surface to tolerances for floor flatness (FF) of 15 and floor levelness (FL) of 13.
- c. Slope surfaces uniformly to drain where required.
- d. After leveling, roughen surface before final set, with stiff brushes, brooms, or rakes.

2. Float Finish:

- a. Apply float finish to monolithic slab surface to receive trowel finish and other finishes as hereinafter specified, and slab surfaces which are to be covered with membrane or elastic waterproofing membrane or elastic roofing, or sand-bed terrazzo, and as otherwise indicated.
- b. After screeding, consolidating, and leveling concrete slabs, do not work surface until ready for floating.
- c. Begin floating when surface water has disappeared or when concrete has sufficiently stiffened to permit operation of power-driven floats, or both.
- d. Consolidate surface with power-driven floats or by hand-floating if area is small or inaccessible to power units.

- e. Check and level surface plane to tolerances of FF 18 - FL 15.
 - f. Cut down high spots and fill low spots.
 - g. Uniformly slope surfaces to drains.
 - h. Immediately after leveling, refloat surface to a uniform, smooth, granular texture.
3. Trowel Finish:
- a. Apply trowel finish to monolithic slab surfaces to be exposed-to-view, and slab surfaces to be covered with resilient flooring, carpet, ceramic or quarry tile, paint, or other thin film finish coating system.
 - b. After floating, begin first trowel finish operation using a power-driven trowel.
 - c. Begin final troweling when surface produces a ringing sound as trowel is moved over surface.
 - d. Consolidate concrete surface by final hand-troweling operation, free of trowel marks, uniform in texture and appearance, and with surface leveled to tolerances of FF 20 - FL 17.
 - e. Grind smooth surface defects which would telegraph through applied floor covering system.
4. Trowel and Fine Broom Finish:
- a. Where ceramic or quarry tile is to be installed with thin-set mortar, apply trowel finish as specified, then immediately follow with slightly scarifying surface by fine brooming.
5. Non-Slip Broom Finish:
- a. Apply non-slip broom finish to exterior concrete platforms, steps, and ramps, and elsewhere as indicated.
 - b. Immediately after float finishing, slightly roughen concrete surface by brooming with fiber bristle broom perpendicular to main traffic route.
 - c. Coordinate required final finish with the ENGINEER before application.

3.11 CONCRETE CURING AND PROTECTION

A. General:

1. Protect freshly placed concrete from premature drying and excessive cold or hot temperatures.
2. Start initial curing as soon as free water has disappeared from concrete surface after placing and finishing.
3. Continuously keep concrete moist for not less than 7 days, weather permitting.
4. Begin final curing procedures immediately following initial curing and before concrete has dried.
5. Continue final curing for at least 7 days in accordance with ACI 301 procedures.
6. Avoid rapid drying at end of final curing period.

B. Curing Methods:

1. Perform curing of concrete by curing and sealing compound, by moist curing, by moisture-retaining cover curing, and by combinations thereof, as herein specified.
2. Provide moisture curing by the following methods:
 - a. Keep concrete surface continuously wet by covering with water.
 - b. Continuous water-fog spray.
 - c. Covering concrete surface with specified absorptive cover, thoroughly saturating cover with water and continuously keeping wet.
 - d. Place absorptive cover to provide coverage of concrete surfaces and edges, with 4-inch lap over adjacent absorptive covers.
3. Provide moisture-cover curing as follows:
 - a. Cover concrete surfaces with moisture-retaining cover for curing concrete, placed in widest practicable width with sides and ends lapped at least 3 inches and sealed by waterproof tape or adhesive.
 - b. Immediately repair any holes or tears during curing period using cover material and waterproof tape.

4. Provide curing slabs and sealing compounds to exposed interior slabs and to exterior slabs, walks, and curbs, as follows:
 - a. Apply specified curing and sealing compound to concrete slabs as soon as final finishing operations are complete (within 2 hours).
 - b. Uniformly apply in continuous operation by power-spray or roller in accordance with Manufacturer's directions.
 - c. Recoat areas subjected to heavy rainfall within 3 hours after initial application.
 - d. Maintain continuity of coating and repair damage during curing period.
5. Do not use membrane curing compounds on surfaces that are to be covered with coating material applied directly to concrete, liquid floor hardener, waterproofing, dampproofing, membrane roofing, flooring (such as ceramic or quarry tile and glue-down carpet), painting, and other coatings and finish materials, unless otherwise acceptable to the ENGINEER.
6. Curing Formed Surfaces:
 - a. Cure formed concrete surfaces, including undersides of beams, supported slabs, and other similar surfaces by moist curing with forms in place for full curing period or until forms are removed.
 - b. If forms are removed, continue curing by methods specified above, as applicable.
7. Curing Unformed Surfaces:
 - a. Cure unformed surfaces, such as slabs, floor topping, and other flat surfaces by application of appropriate curing method.
 - b. Final cure concrete surfaces to receive liquid floor hardener or finish flooring by use of moisture-retaining cover, unless otherwise directed.
8. Sealer and Dustproofers:
 - a. Apply a second coat of specified curing and sealing compound only to surfaces given a first coat.

3.12 SHORES AND SUPPORTS

- A. Remove shoring from ground to roof for structures four stories or less, unless otherwise permitted.
- B. Remove shores and re-shore in a planned sequence to avoid damage to partially cured concrete.
- C. Locate and provide adequate re-shoring to safely support work without excessive stress or deflection.
- D. Keep shores in place a minimum of 15 days after placing upper tier, and longer if required, until concrete has attained its required 28-day strength and heavy loads due to construction operations have been removed.

3.13 REMOVAL OF FORMS

- A. Formwork not supporting weight of concrete, such as sides of beams, walls, columns, and similar parts of the work, may be removed after cumulatively curing at no less than 50 degrees F (10 degrees C) for 24 hours after placing concrete, provided concrete is sufficiently hard to not be damaged by form removal operations, and provided curing and protection operations are maintained.
- B. Form facing material may be removed 4 days after placement, only if shores and other vertical supports have been arranged to permit removal of form facing material without loosening or disturbing shores and supports.

3.14 RE-USE OF FORMS

- A. Clean and repair surfaces of forms to be re-used in work. Split, frayed, delaminated, or otherwise damaged form facing material will not be acceptable for exposed surfaces.
- B. Apply new form coating compound as specified for new formwork.
- C. Thoroughly clean surfaces, remove fins and laitance, and tighten forms to close joints when forms are extended for successive concrete placement.
- D. Align and secure joint to avoid offsets. Do not use "patched" forms for exposed concrete surfaces, except as acceptable to the ENGINEER.

3.15 MISCELLANEOUS CONCRETE ITEMS

A. Filling-In:

1. Fill-in holes and openings left in concrete structures for passage of work by other trades, unless otherwise shown or directed, after work of other trades is in place.
2. Mix, place, and cure concrete as herein specified, to blend with in-place construction.
3. Provide other miscellaneous concrete filling shown or required to complete work.

B. Curbs:

1. Provide monolithic finish to interior curbs by stripping forms while concrete is still green and steel troweling surfaces to a hard, dense finish with corners, intersections, and terminations slightly rounded.

C. Equipment Bases and Foundations:

1. Provide machine and equipment bases and foundations, as shown on Drawings.
2. Set anchor bolts for machines and equipment to template at correct elevations, complying with certified diagrams or templates of Manufacturer furnishing machines and equipment.
3. Grout base plates and foundations as indicated, using specified non-shrink grout.
4. Use non-metallic grout for exposed conditions, unless otherwise indicated.

D. Reinforced Masonry:

1. Provide concrete grout for reinforced masonry lintels and bond beams where indicated on Drawings and as scheduled, including filling of concrete modular unit cavities where called for on plans.
2. Maintain accurate location of reinforcing steel during concrete placement.

3.16 CONCRETE SURFACE REPAIRS

A. Patching Defective Areas:

1. Repair and patch defective areas with cement mortar immediately after removal of forms, when acceptable to the ENGINEER.
2. Cut out honeycomb, rock pockets, voids over 1/4 inch in any dimension, and holes left by tie rods and bolts, down to solid concrete but, in no case to a depth of less than 1 inch.
3. Make edges of cuts perpendicular to the concrete surface.
4. Thoroughly clean, dampen with water, and brush-coat the area to be patched with specified bonding agent.
5. Place patching mortar after bonding compound has dried.

B. Repair of Formed Surfaces:

1. Remove and replace concrete having defective surfaces if defects cannot be repaired to the satisfaction of the ENGINEER. Surface defects, as such, include:
 - a. Color and texture irregularities, cracks, spalls, air bubbles, honeycomb, rock pockets.
 - b. Fins and other projections on surface.
 - c. Stains and other discolorations that cannot be removed by cleaning.
2. Flush out form tie holes, fill with dry pack mortar, or precast cement cone plugs secured in place with bonding agent.
3. Repair concealed formed surfaces, where possible, that contain defects that affect the durability of concrete. If defects cannot be repaired, remove and replace concrete.

C. Repair of Unformed Surfaces:

1. Test unformed surfaces, such as monolithic slabs, for smoothness and verify surface plane to tolerances specified for each surface and finish.
2. Correct low and high areas as herein specified.
3. Test unformed surfaces sloped to drain for trueness of slope, in addition to smoothness using a template having required slope.

- D. Repair finished unformed surfaces that contain defects which affect durability of concrete. Surface defects, as such, include crazing cracks in excess of 0.01 inch wide or which penetrate to reinforcement or completely through non-reinforced sections regardless of width, spalling, pop-outs, honeycomb, rock pockets, and other objectionable conditions.
 - 1. Correct high areas in unformed surfaces by grinding, after concrete has cured at least 14 days.
 - 2. Correct low areas in unformed surfaces during or immediately after completion of surface finishing operations by cutting out low areas and replacing with fresh concrete.
 - 3. Finish repaired areas to blend into adjacent concrete.
 - 4. Proprietary patching compounds may be used when acceptable to the ENGINEER.

- E. Repair Defective Areas:
 - 1. Cut out and replace with fresh concrete except random cracks and single holes not exceeding 1 inch in diameter.
 - 2. Remove defective areas to sound concrete with clean, square cuts and expose reinforcing steel with at least ¾-inch clearance all around.
 - 3. Dampen concrete surfaces in contact with patching concrete and apply bonding compound.
 - 4. Mix patching concrete of same materials to provide concrete of same type or class as original concrete.
 - 5. Place, compact, and finish to blend with adjacent finished concrete.
 - 6. Cure in same manner as adjacent concrete.

- F. Perform structural repairs with prior approval of Structural Engineer for method and procedure, using specified epoxy adhesive and mortar.

- G. Use repair methods not specified above, subject to acceptance of the ENGINEER.

3.17 QUALITY CONTROL TESTING DURING CONSTRUCTION

- A. The OWNER will employ a testing laboratory to perform tests and to submit test reports.
- B. Sampling and testing for quality control during placement of concrete may include the following, as directed by the ENGINEER.
 - 1. Sampling Fresh Concrete:
 - a. ASTM C 172, except modified for slump to comply with ASTM C 94.
 - 2. Slump:
 - a. ASTM C 143, one test at point of discharge for each day's pour of each type of concrete and additional tests when concrete consistency seems to have changed.
 - 3. Concrete Temperature:
 - a. Test hourly when air temperature is 40 degrees F (4 degrees C) and below, and when 80 degrees F (27 degrees C) and above, and each time a set of compression test specimens are made.
 - 4. Compression Test Specimen:
 - a. ASTM C 31, one set of four standard cylinders for each compressive strength test, unless otherwise directed.
 - b. Cylinders for laboratory cured test specimens shall be molded and stored except when field-cure test specimens are required.
 - 5. Compressive Strength Tests:
 - a. ASTM C 39, one set for each day's pour exceeding 5 cubic yards plus additional sets for each 50 cubic yards over and above the first 25 cubic yards of each concrete class placed in any 1 day:
 - 1) One specimen tested at 7 days.
 - 2) Two specimens tested at 28 days.
 - 3) One specimen retained in reserve for later testing if required.

CITY OF CALLAWAY CHERRY STREET DIRECTIONAL BORE

- b. When frequency of testing will provide less than five strength tests for a given class of concrete, conduct testing from at least five randomly selected batches or from each batch if fewer than five are used.
- C. Test results will be reported in writing to Structural Engineer and the CONTRACTOR within 24 hours after tests.
- D. Reports of compressive strength tests shall contain:
 1. The project identification name and number.
 2. Date of concrete placement.
 3. Name of concrete testing service.
 4. Concrete type and class.
 5. Location of concrete batch in structure.
 6. Design compressive strength at 28 days.
 7. Concrete mix proportions and materials.
 8. Compressive breaking strength.
 9. Type of break for both 7- and 28-day tests.
- E. Nondestructive Testing:
 1. Impact hammer, sonoscope, or other nondestructive device may be permitted but shall not be used as the sole basis for acceptance or rejection.
- F. Additional Tests:
 1. The testing service will make additional tests of in-place concrete when test results indicate specified concrete strengths and other characteristics have not been attained in the structure, as directed by the ENGINEER.
 2. Testing service may conduct tests to determine adequacy of concrete by cored cylinders complying with ASTM C 42, or by other methods as directed.
 3. The CONTRACTOR shall pay for such tests when unacceptable concrete is verified.

END OF SECTION

**SECTION 15010
BASIC MECHANICAL REQUIREMENTS**

PART 1 - GENERAL

1.01 RELATED DOCUMENTS

Drawings and general provisions of Contract, including General and Special Conditions, apply to work of this section.

1.02 SUMMARY

This section specifies the basic requirements for mechanical installations. It expands and supplements the requirements specified in sections under "General Requirements."

1.03 ACCESSIBILITY

- A. The CONTRACTOR shall install equipment and materials to provide required access for servicing and maintenance.
- B. The CONTRACTOR shall coordinate the final location of concealed equipment and devices requiring access with final location of required access panels and doors.
- C. The CONTRACTOR shall allow ample space for removal of all parts that require replacement or servicing.
- D. The CONTRACTOR shall extend all grease fittings to an accessible location.

1.04 MECHANICAL INSTALLATIONS

- A. The CONTRACTOR shall coordinate mechanical equipment and materials installation with other building components.
- B. The CONTRACTOR shall verify all dimensions by field measurements.
- C. The CONTRACTOR shall coordinate the installation of required supporting devices and sleeves to be set in poured in place concrete and other structural components, as they are constructed.
- D. The CONTRACTOR shall sequence, coordinate, and integrate installations of mechanical materials and equipment for efficient flow of the Work.
- E. The CONTRACTOR shall install mechanical equipment to facilitate maintenance and repair or replacement of equipment components. As much as practical, connect equipment for ease of disconnecting, with minimum of interference with other installations.

- F. The CONTRACTOR shall coordinate connection of mechanical systems with exterior underground and overhead utilities and services. Comply with requirements of governing regulations, franchised service companies, and controlling agencies. Provide required connection for each service.

1.05 MECHANICAL SUBMITTALS

- A. Submittal of shop drawings, product data, and samples will be accepted only when submitted by the CONTRACTOR.
- B. Data from subcontractors and material suppliers directly submitted to the Engineer will not be processed.
- C. Five complete sets of all shop drawings and product data shall be submitted by the CONTRACTOR.

1.06 NAMEPLATE DATA

- A. The CONTRACTOR shall provide permanent operational data nameplate on each item of power-operated mechanical equipment, indicating manufacturer, product name, model number, serial number, capacity, operating and power characteristics labels of tested compliances, and similar essential data.
- B. The CONTRACTOR shall locate nameplates in an accessible location.

PART 2 - PRODUCTS

2.01 DELIVERY, STORAGE, AND HANDLING

- A. The CONTRACTOR shall deliver products to the project site that are properly identified with names, model numbers, types, grades, compliance labels, and similar information needed for distinct identifications.
- B. The CONTRACTOR shall adequately package and protect products to prevent damage during shipment, storage, and handling.
- C. The CONTRACTOR shall store equipment and materials at the site, unless off-site storage is authorized in writing.
- D. The CONTRACTOR shall protect stored equipment and materials from damage.

PART 3 - EXECUTION

3.01 RECORD DOCUMENTS

The following paragraphs supplement the requirements in sections under "General Requirements."

- A. The CONTRACTOR shall mark Drawings to indicate revisions to:
 - 1. Piping, size and location both exterior and interior.
 - 2. Actual equipment locations, dimensioned for column lines.
 - 3. Actual inverts and locations of underground piping.
 - 4. Concealed equipment, dimensioned to column lines.
 - 5. Mains and branches of piping systems, with valves and control devices located and numbered
 - 6. Concealed unions located, and with items requiring maintenance located (i.e., traps, strainers, expansion compensators, tanks, etc.).
 - 7. Concealed control system devices.
- B. The CONTRACTOR shall mark Specifications to indicate approved substitutions, Change Orders, and actual equipment and materials used.

3.02 OPERATION AND MAINTENANCE DATA

Refer to Section 01705 (Project Closeout) for procedures and requirements for preparing and submitting operation and maintenance manuals.

- A. The CONTRACTOR shall Include the following information:
 - 1. Description of function, normal operating characteristics and limitations, performance curves, engineering data and tests, and complete nomenclature and commercial numbers of all replaceable parts.
 - 2. Manufacturer's printed operating procedures to include:
 - a. Start-up, break-in, routine and normal operating instructions.
 - b. Regulation, control, stopping, shut-down, and emergency instructions.
 - c. Summer and winter operating instructions.

3. Maintenance procedures for:
 - a. Troubleshooting and routine preventative maintenance.
 - b. Disassembly, repair, and reassembly.
 - c. Aligning and adjusting.
4. Servicing instructions and lubrication charts and schedules.

3.03 WARRANTIES

- A. The CONTRACTOR shall compile and assemble the warranties into a separated set of vinyl covered, three-ring binders, tabulated and indexed for easy reference.
- B. The CONTRACTOR shall provide for all products and equipment used on the project, complete warranty information including:
 1. Date of beginning of warranty or bond.
 2. Duration of warranty or bond.
 3. Contact information (e.g., names, addresses, and telephone numbers) and procedures for filing a claim and obtaining warranty services.

END OF SECTION

**SECTION 15051
MECHANICAL RELATED WORK**

PART 1 - GENERAL

1.01 RELATED DOCUMENTS

Drawings and general provisions of Contract, including General and Special Conditions, apply to Work of this section.

1.02 DESCRIPTION OF WORK

- A. Extent of mechanical related work and work required by this section is indicated on drawings and/or specified in other sections of these Specifications.
- B. The CONTRACTOR shall furnish all labor, material, and equipment, and the CONTRACTOR shall perform all operations required to satisfactorily and properly install, adjust, test and place into operation all equipment and system shown on the construction Drawings.
- C. The CONTRACTOR shall submit submittal data and as-built drawings for each piece of equipment or installation.

1.03 EQUIPMENT INSTALLATION

- A. The CONTRACTOR shall install all equipment and systems shown on the Drawings and/or specified herein in a workmanlike manner and in strict accordance with the Manufacturer's recommendations.
- B. The CONTRACTOR shall furnish and connect all required piping, electrical connections, and other necessary items to provide a complete operating facility.

1.04 EQUIPMENT TESTING AND ADJUSTING

- A. The CONTRACTOR shall demonstrate that all equipment is operating in a satisfactory manner after installation.
- B. The CONTRACTOR shall lubricate all equipment according to vendors' recommendations and shall make all adjustments to suit anticipated operating conditions.
- C. The CONTRACTOR shall test each piece of equipment to show that it operates quietly, without vibration, overheating, or signs of distress, at full specified capacity.
- D. The CONTRACTOR shall make adjustments as necessary.

CITY OF CALLAWAY CHERRY STREET DIRECTIONAL BORE

- E. The CONTRACTOR shall replace all defective parts of machinery, equipment, or materials.
- F. The CONTRACTOR shall secure and submit to the ENGINEER, vendor's certificates detailing that the installation of equipment is in accordance with the Manufacturer's recommendations.
- G. The CONTRACTOR shall submit to the ENGINEER five copies of all necessary manuals and instructions describing the proper operation and maintenance of each type of equipment furnished.

1.05 INSTALLATION SUPERVISION

- A. The CONTRACTOR shall install, initially start up, and operate all equipment shall under the supervision of a factory-trained technical representative of the Manufacturer.
- B. Manufacturer representative's services shall include instruction from the OWNER's operator in the operation, maintenance, and adjustment of the equipment.
- C. The CONTRACTOR shall give the ENGINEER and OWNER's operator 48 hours notice before start-up. Start-up shall not proceed without the presence of the ENGINEER.

1.06 EQUIPMENT REQUIREMENTS

The following requirements shall apply to equipment furnished in the Contracts:

- A. Each piece of mechanical equipment and motors shall be provided with a substantial nameplate of non-corrodible metal, securely fastened in place, clearly and permanently inscribed with the Manufacturer's name, model or type designation, serial number, rated capacity, electrical or other power characteristics, and other appropriate nameplate data.
- B. All equipment shall be delivered fully lubricated with oil and/or grease insofar as possible. If any point cannot be so serviced, it shall be clearly marked to the effect that it is not lubricated and requires servicing prior to operation. An adequate supply of the proper lubricant, with instructions for its application, shall be supplied with the equipment for each point not lubricated prior to shipment. The CONTRACTOR shall also provide the OWNER with a sufficient amount of proper lubricants for one complete change of lubricant for all equipment furnished.
- C. All factory-painted equipment shall be provided with 2 pints of touch up paint to match original finish along with instructions for application.

CITY OF CALLAWAY CHERRY STREET DIRECTIONAL BORE

PART 2 - PRODUCTS (Not Applicable)

PART 3 - EXECUTION (Not Applicable)

END OF SECTION

**SECTION 15065
PIPE AND FITTINGS FOR WASTEWATER**

PART 1 - GENERAL

1.01 SCOPE OF WORK:

- A. The CONTRACTOR will furnish all labor, materials, equipment, and incidentals required.
- B. The CONTRACTOR shall install the plastic piping, fittings, and appurtenances as specified in the locations as shown on the Drawings.
- C. The CONTRACTOR shall use American Water Works Association (AWWA) Standard C-900, Polyvinyl Chloride (PVC) pipe for all wastewater force mains with a diameter 4 through 12 inches, 14 inches and longer shall be C-905.
- D. The Extent of the AWWA Standard C-900, PVC pipe is shown on the Drawings.

1.02 DESCRIPTION OF SYSTEM:

Piping shall be installed in the locations as shown on the Drawings.

1.03 QUALIFICATIONS:

- A. All plastic pipe, fittings, and appurtenances shall be furnished by a single Manufacturer who is fully experienced, reputable, and qualified in the manufacture of the items to be furnished.
- B. The equipment shall be designed, constructed, and installed in accordance with the best practices and methods and shall comply with these specifications.

1.04 SUBMITTALS:

- A. The CONTRACTOR shall submit Shop Drawings to the ENGINEER and shall include dimensions and technical specifications for all piping.
- B. The CONTRACTOR shall submit samples of all materials specified herein to the ENGINEER.
- C. The CONTRACTOR shall submit and shall comply with pipe Manufacturer's recommendation for handling, storing, and installing pipe and fittings.
- D. The CONTRACTOR shall submit pipe Manufacturer's certification of compliance with these specifications.

1.05 TOOLS:

Special tools, solvents, lubricants, and caulking compounds required for normal installation shall be furnished with the pipe.

PART 2 - PRODUCTS

2.01 MATERIALS:

A. Class-Rated Polyvinyl Chloride (PVC) Pipe:

1. Class-rated PVC pipe and accessories 4 to 12 inches in diameter, where shown or as specified on the Drawings, shall meet the requirements of AWWA Specification C-900 "Polyvinyl Chloride (PVC) Pressure Pipe." Pipe shall be Class 150, meeting requirements of Dimension Ratio (DR) 18 and shall have the dimension of ductile iron outside diameters.
2. PVC pipe 14 through 36 inches shall meet the requirements of AWWA Standard C-905, Polyvinyl Chloride (PVC) wastewater forcemain pipe, nominal diameters 14 through 36 inches. Pipe shall be Class 150 and meet the requirements of dimension ratio (DR) 18 and shall have the dimension of ductile iron outside diameters.
3. Pipe shall be listed by Underwriters Laboratories.
4. Provisions shall be made for expansion and contraction at each joint with an elastomeric ring, and shall have an integral thickened bell as part of each joint.
5. PVC Class pipe shall be installed as recommended by the Manufacturer.
6. Pipe shall be furnished in nominal lengths of approximately 20 feet, unless otherwise directed by the ENGINEER.
7. Pipe and accessories shall bear the NSF mark indicating pipe size, Manufacturer's names, AWWA and/or American Society for Testing and Materials (ASTM) specification number, working pressure, and production code.
8. Pipe shall be green for sewage force mains.

B. Joints:

1. The PVC joints for pipe shall be of the push-on type unless otherwise directed by the ENGINEER so that the pipe and fittings may be connected on the job without the use of solvent cement or any special equipment.
2. The push-on joint shall be a single rubber gasket joint designed to be

assembled by the positioning of a continuous, molded rubber ring gasket in annular recess in the pipe or fitting socket and the forcing of the plain end of the entering pipe into the socket; thereby, compressing the gasket radially to the pipe to form a positive seal.

3. The gasket and annular recess shall be designed and shaped so that the gasket is locked in place against displacement as the joint is assembled. The rubber ring joint shall be designed for thermal expansion or contraction with a total temperature change of at least 750 degrees Fahrenheit in each joint per length of pipe.
4. The bell shall consist of an integral wall section with a solid cross section elastomeric ring which shall meet requirements of ASTM F-477. The thickened bell section shall be designed to be at least as strong as the pipe wall. Lubricant furnished for lubricating joints shall be nontoxic, shall not support the growth of bacteria, shall not have deteriorating effects on the gasket or pipe material, and shall not impart color, taste, or odor to the water.
5. PVC joints for pipe less than 3 inches in diameter shall either be threaded, push-on type, SCH. 80 PVC. Teflon thread tape or liquid teflon thread lubricant shall be used on all threaded joints to serve as both a sealer and lubricant. Threaded joints should be made hand tight (hard). When the joint is hand tight, a strap wrench should be used to make up one to two additional full turns past the hand right point. Do not use pipe wrenches or pump pliers on plastic pipe or fittings.

C. Fittings:

All fittings for PVC pipe shall be cast iron/ductile iron with mechanical joints and shall conform to the specifications for cast iron/ductile iron fittings, unless otherwise directed. PVC C-900 fittings are allowable upon approval by the ENGINEER and required for sewage force main applications. DR ratio shall be the same as the pipe.

1. Fittings for Schedule 80 PVC pipe less than 3 inches in diameter shall be threaded and be PVC as shown on the Drawings, or as directed by the ENGINEER. Threaded PVC fittings shall conform to ASTM Specification D2464-69).
2. The Manufacturer of the pipe shall supply all PVC accessories as well as any adaptors and/or specials required to perform the work as shown on the Drawings and specified herein. Standard double bell couplings will not be accepted where the pipe will slip completely through the coupling.

PART 3 - EXECUTION

3.01 STORAGE/INSTALLATION:

- A. The CONTRACTOR shall store and install plastic pipe strictly in accordance with Manufacturer's technical data and printed instruction.
- B. The CONTRACTOR shall properly cover all plastic pipe to prevent fading.
- C. The OWNER reserves the right to reject any pipe not properly stored or pipe that has faded.

3.02 INSPECTION AND TESTING:

- A. The CONTRACTOR shall not disturb all pipelines for 24 hours to develop complete strength at all joints.
- B. General:
 - 1. Provide temporary equipment for testing, including pump and gauges.
 - 2. Test piping system before insulation is installed (wherever feasible) and remove control devices before testing.
 - 3. Expel air from the pipe before applying the specified test pressure.
 - 4. Make taps (if necessary) at points of highest elevation, and afterwards tightly plugged.
 - 5. Test each natural section of each piping system independently but do not use piping system valves to isolate sections where test pressure exceeds valve pressure rating.
 - 6. Fill each section with water and subject to a hydrostatic pressure equal to the pressure rating of the pipe being tested.
- A. The CONTRACTOR shall test for the required 2 hour period or until the line has been completely inspected for visual leaks.
- B. The CONTRACTOR shall test pipe at 150 psi, except where fittings are lower class or pressure rating.
- C. The CONTRACTOR shall repair piping systems sections which fail required piping tests, by disassembly and re-installation using new materials to the extent required to overcome leakage. Do not use chemicals, stop-leak compounds, mastics, or other temporary repair methods.
- D. The CONTRACTOR shall, at his own expense, locate and repair the defective

joints should any test of combined sections of pipe laid disclose leakage greater than the specified limit, until the leakage is within the specified allowance.

- E. The CONTRACTOR shall provide water for testing.
- F. The CONTRACTOR may subject pipe to hydrostatic pressure, inspect and test for leakage at any convenient time after partial completion of backfill.
- G. The CONTRACTOR may test the system with joints exposed or backfilling complete at his/her option.
- H. The ENGINEER shall be notified at least 48 hours before beginning testing.
- I. The CONTRACTOR shall drain test water from piping systems after testing and repair work has been completed.

3.03 CLEANING, FLUSHING, AND INSPECTING:

- A. General:
 - 1. Clean exterior surfaces of installed piping systems of superfluous materials, prepare for application of specified coatings (if any).
 - 2. Flush out piping systems with clean water before proceeding with required tests.
 - 3. Inspect each run of each system for completion of joints, supports and accessory items.
- B. The CONTRACTOR shall inspect pressure piping in accordance with procedures of American Society of Mechanical Engineers (ASME) B31.

END OF SECTION

**SECTION 15070
HDPE PIPE**

PART 1 - GENERAL

1.01 SCOPE OF WORK

- A. This section includes material and installation requirements necessary for furnishing and installing high-density polyethylene (HDPE) pipe, fittings, and specials in the locations and quantities as shown on the drawings.
- B. Quantities shown on the plans may not be the exact length needed for directional bores.
- C. The CONTRACTOR shall investigate this before the Bid and shall inform the ENGINEER prior to the Bid if additional HDPE pipe will be needed.
- D. The CONTRACTOR will be responsible for any additional HDPE pipe needed after the Bid and additional costs incurred for the pipe shall not be required from the OWNER.

1.02 QUALITY CRITERIA

- A. Reference to industry standards as contained herein shall be construed as to be in reference to the latest revision or edition. All HDPE pipe shall meet all American Water Works Association (AWWA) Standards.
- B. The pipe fittings and specials shall be made by a Manufacturer experienced in producing pipe, fittings, and specials of the type, size, configuration, and quality specified herein. The manufacturer shall have produced pipe, fittings and specials having a record of at least 5 years successful performance.

1.03 SUBMITTALS

- A. The CONTRACTOR shall submit Shop Drawings showing the pipe lengths, design details, joint details, specials, etc., for the ENGINEER's approval. Pipe shall be fabricated in accordance with these plans.
- B. The CONTRACTOR shall submit a notarized statement of certification from the pipe Manufacturer as to conformance with the specified American National Standards Institute (ANSI)/AWWA Specifications listed herein, and modifications thereto, at the time of submitting Shop Drawing data on the pipe and fittings.

1.04 DELIVERY, STORAGE AND HANDLING

- A. The CONTRACTOR shall be responsible for the acceptability of all material furnished by him/her and shall assume responsibility for the replacement of all such material found damaged in shipping or defective in manufacture. This shall include furnishing all material and labor required for the replacement of installed material discovered to be defective prior to the final acceptance of the Work.
- B. The CONTRACTOR shall keep the interior and all sealing surfaces of all pipe, fittings, and other accessories free from dirt and foreign matter. Consult the Manufacturer for specific storage recommendations.
- C. The CONTRACTOR shall properly handle materials at all times to prevent damage in accordance with Manufacturer's recommendations. Pipe and fittings shall not be thrown, dropped, or dragged.

PART 2 - PRODUCTS

2.01 HDPE PIPE

- A. The HDPE pipe shall be manufactured in accordance with American Society for Testing and Materials (ASTM) F714. All HDPE pipe used for force mains shall have an embedded green stripe on each side symbolizing wastewater and all HDPE pipe used for water mains shall have an embedded blue stripe on each side symbolizing water.
- B. The HDPE pipe shall be rated for use with water at 73.4 degrees Fahrenheit (F) at a hydrostatic design stress of 800 psi and a minimum working pressure of 160 psi.
- C. Dimension Ratio (DR) shall be DR11 for the HDPE pipe shown on the drawings. All HDPE pipe shall be ductile iron pipe size (DIPS).
- D. Polyethylene extrusion compound from which the HDPE pipe is extruded shall comply with application requirements for PE-3408 high molecular weight polyethylene plastic material. Material shall be as described in ASTM D1248 and shall comply with the following:
 - 1. Pipe resin shall have a minimum inherent viscosity of 2.5 when run according to ASTM D1601.
 - 2. Exceed 5,000 hours on ESC as determined by ASTM D-1248-345434C.
 - 3. Have a specific gravity of between 0.9141 and 0.955.
 - 4. Contain a minimum of 2% and a maximum of 3% of carbon black and shall produce a finish product that is uniformly black.

- E. Marking on the HDPE pipe shall include:
1. The nominal pipe or tubing size.
 2. The type of plastic material (i.e., PE-3408).
 3. The standard thermoplastic pipe dimension ratio or the pressure rating in psi for water at 73.4°F. (160 psi).
 4. The ASTM designation with which the pipe complies.
 5. The Manufacturer's name or trade mark and code.

2.02 FITTINGS AND JOINTS

- A. Fittings shall be fabricated to the same standards as the pipe from the same raw materials by thermal fusion.
- B. Jointing shall be by the thermal butt fusion method as recommended by the Manufacturer.
- C. Fittings and joints shall have a pressure rating equal to the pipe and shall have machined fusion ends matched to pipe wall.
- D. The CONTRACTOR shall use mechanical joint fusion welded adapters with ductile iron mechanical joint sleeves for transition connections as shown on the plans.

PART 3 - EXECUTION

3.01 GENERAL REQUIREMENTS

- A. The CONTRACTOR shall install of all HDPE pipe, fittings, specials, and appurtenances in accordance with the Manufacturer's instructions.
- B. The CONTRACTOR shall securely close openings such as stubs, tees and other services along the lines with an approved stopper that fits into the pipe and is recommended by the pipe Manufacturer. This stopper shall be jointed in such a manner that it may be removed at some future time without injury to the pipe itself.
- C. The CONTRACTOR shall temporarily close the end of the pipe with a close-fitting stopper at the close of each day's work and at other times when the pipe is not being laid.

- D. Cleaning:
1. All necessary precautions shall be taken to prevent the entrance of mud, sand or other obstructing material into the pipelines.
 2. As the work progresses, the interior of the main shall be cleaned of all dirt, jointing material, and superfluous materials of every description.
- E. Experienced fusion technicians with a minimum of 5 years or more experience in field application involving large diameter (over 12 inches) HDPE pipe shall join piping. Experience record shall be submitted for review 15 days prior to directional boring activities.
- F. If the CONTRACTOR feels that the length of HDPE pipe shown on the plans is not adequate, then the CONTRACTOR shall notify the ENGINEER prior to the Bid. The CONTRACTOR shall not ask for additional directional boring cost after the Bid.
- G. Handling:
1. Pipe must be handled in a way to ensure that it is not gouged or scratched to a depth of more than 10% of the wall thickness.
 2. Pipe shall not be bent to a radius of less than the Manufacturer's recommendation at any time during installation.
 3. Pipe shall be handled at all times with strapping that a combined width at each load area of at least half the pipe diameter to prevent point damage to the pipe. No wire rope slings shall be used.

PART 4 – TESTING

4.01 TESTING IN THE TRENCH

- A. The CONTRACTOR shall fill the pipeline with water after it has been laid; bleed off any trapped air.
- B. The CONTRACTOR shall subject the lowest element in the system to a test pressure that is 1.5 times the design pressure and check for any leakage.
- C. The CONTRACTOR shall apply the pressure test after backfilling has been completed but not sooner than a time which will allow sufficient curing of any concrete that may have been used, when in the opinion of the ENGINEER, local conditions require that the trenches be backfilled immediately after the pipe has been laid. Typical minimum concrete curing times are 36 hours for early strengths and 7 days for normal strengths.

CITY OF CALLAWAY CHERRY STREET DIRETIONAL BORE

1. The test procedures consist of two steps: the initial expansion and the test phase.
2. When test pressure is applied to a water-filled pipe, the pipe expands. During the initial expansion of the pipe under test sufficient make-up water must be added to the system at hourly intervals for 3 hours to maintain the test pressure.
3. After about 4 hours, initial expansion should be complete and the actual test can start.
4. When the test is to begin, the pipe is full of water and is subjected to a constant test pressure of 1.5 times the system design pressure.
5. The test phase should not exceed 3 hours, after which time any water deficiency must be replaced and measured. Add and measure the amount of make-up water required to return to the test pressure and compare this to the maximum allowance in **Figure 4.1**.
6. An alternate leakage test consists of maintaining the test pressure (described above) over a period of 4 hours, and then dropping the pressure by 10 psi (0.069 Mpa). If the pressure that remains is within 5% of the target value for 1 hour, then that is an indication that there is no leakage in the system.

NOTE: *Under no circumstances shall the total time under test exceed 8 hours at 1 ½ times the system pressure rating. If the test is not complete within this time limit (due to leakage, equipment failure, etc.), the test section shall be permitted to “relax” for 8 hours prior to the next test sequence. Air testing is not recommended. Additional safety precautions may be required.*

FIGURE 4.1
ALLOWANCE FOR EXPANSION UNDER TEST PRESSURE

Nominal Pipe Size Inches (1)	U.S. Gals/100 feet of Pipe (2)			Nominal Pipe Size Inches (1)	U.S. Gals/100 feet of Pipe (2)		
	1-Hour	2-Hour	3-Hour		1-Hour	2-Hour	3-Hour
2	0.08	0.12	0.15	20	2.80	5.50	8.00
3	0.10	0.15	0.25	22	3.50	7.00	10.50
4	0.13	0.25	0.40	24	4.50	8.90	13.30
5	0.21	0.41	0.63	28	5.50	11.10	16.80
6	0.30	0.60	0.90	30	6.20	12.60	19.10
8	0.50	1.00	1.50	32	7.00	14.30	21.50
10	0.75	1.30	2.10	36	9.00	18.00	27.00
12	1.10	2.30	3.40	42	12.00	24.00	36.00
14	1.40	2.80	4.20	48	15.00	27.00	43.00
16	1.70	3.30	5.00	54	18.00	30.00	50.00
18	2.20	4.30	6.50				

(1) mm* 0.03937

(2) multiply by 11.53 to convert to liter/100 meters of pipe

END OF SECTION

**SECTION 15090
SPECIFICATIONS FOR DUCTILE IRON PIPE & FITTINGS**

PART 1 – GENERAL:

1.01 REQUIREMENT:

A. General:

The CONTRACTOR shall furnish and install Ductile Iron Pipe and all appurtenances, complete in place, all in accordance with the requirements of the Contract Documents. Where standards, specifications or methods are cited without dates, the reference shall be construed to apply to the latest revision in effect at the time of contract.

B. Manufacturer:

The term “Manufacturer” shall mean the party that manufactures, fabricates, or produces materials or products.

1.02 REFERENCE SPECIFICATIONS, CODES, AND STANDARDS:

A. Commercial Standards:

ANSI/AWWA C104/A21.4	Cement-Mortar Lining for Ductile-Iron Pipe and Fittings for Water
ANSI/AWWA C105/A21.5	Polyethylene Encasement for Ductile-Iron Pipe Systems
ANSI/AWWA C110/A21.10	Ductile-Iron and Gray-Iron Fittings, 3-in through 48-in for Water and Other Liquids
ANSI/AWWA C111/A21.11	Rubber-Gasket Joints for Ductile-Iron Pressure Pipe and Fittings
ANSI/AWWA C115/A21.15	Flanged Ductile-Iron Pipe with Ductile-Iron or Gray-Iron Threaded Flanges
ANSI/AWWA C150/A21.50	Thickness Design of Ductile-Iron Pipe
ANSI/AWWA C151/A21.51	Ductile-Iron Pipe, Centrifugally Cast for Water
ANSI/AWWA C153/A21.53	Ductile-Iron Compact Fittings, 3-in through 24-in and 54-in through 64-in for Water Service
ANSI/AWWA C600	Installation of Ductile-Iron Water Mains and their Appurtenances
ANSI/AWWA C606	Grooved and Shouldered Joints
ANSI/AWS D11.2	Guide for Welding Iron Casting

Note: Hereafter in this specification the specific referenced American National Standards Institute (ANSI)/American Water Works Association (AWWA) standards are referred to either by their full description as in the first column of the above standards list, or only by their abbreviated AWWA "C" designation (e.g., AWWA C151 is meant to refer to ANSI/AWWA C151/A21.51, etc.).

1.03 CONTRACTOR SUBMITTALS:

A. Shop Drawings/Lay Schedules:

The CONTRACTOR upon request shall submit catalog cuts of pipe and fittings in accordance with the requirements of this section.

1. Certified dimensional drawings of all valves, fittings, and appurtenances.
2. Certified dimensional drawings of joints, showing the Manufacturer's allowable deflections.
3. Copies of the Manufacturer's approved installation instructions for the types of joints being used.

B. Certifications:

Upon request, the CONTRACTOR shall furnish a certified affidavit of compliance for all pipe and other products or materials furnished under this section, as specified in the referenced standards and as specified in Section 1.04 – Quality Assurance.

C. Sample Costs:

All expenses incurred in making samples for certification of specified tests shall be borne by the MANUFACTURER.

1.04 QUALITY ASSURANCE

A. Inspection:

All pipe shall be subject to inspection at the place of manufacture, in accordance with the provisions of the referenced standards, as supplemented by the requirements herein.

B. Plant Access:

During the manufacture of the pipe, the ENGINEER shall be given access to all areas where manufacturing and testing is in process and shall be permitted to make all inspections necessary to confirm compliance with the Specifications.

CITY OF CALLAWAY CHERRY STREET DIRECTIONAL BORE

C. Tests:

Except as modified herein, all materials used in the manufacture of the pipe shall be tested in accordance with requirements as applicable.

D. Test Costs:

The MANUFACTURER shall perform said material tests at no additional cost to the OWNER. The ENGINEER shall have the right to witness all testing conducted by the MANUFACTURER, provided that the MANUFACTURER's and CONTRACTOR's schedule is not delayed for the convenience of the ENGINEER.

E. ISO/Third Party Inspection:

1. All pipe material suppliers shall be ISO 9001 or 9002 registered or provide the services of an Independent Inspection Agency. ISO 9001 or 9002 registration shall have been certified by a qualified ISO registrar. Prior to the start of manufacturing, any manufacturer not meeting the ISO registration requirements shall submit to the OWNER or OWNER's ENGINEER, for approval, a list of qualifications for a minimum of three independent inspection agencies. These qualifications shall include but are not limited to the following:

- a. List of project references for projects of similar type and size
- b. Resumes for inspection and testing personnel
- c. Capacities for chemical and physical testing of material specimens
- d. Frequencies for all instrument and testing equipment certifications

2. The independent testing agency will be responsible for observing, verifying, and documenting all quality assurance testing for the production of pipe material produced for this project. Independent inspection agency shall ensure that all pipe sections produced for this project have traceability such that each individual pipe section can be referenced to the following chemical, physical, and performance tests:

- a. Chemistry
 - 1) Ladle Number
 - 2) Ladle Chemistry
- b. Mold Number
 - 1) Mold Production History
- c. Bracketed Physical Testing

CITY OF CALLAWAY CHERRY STREET DIRECTIONAL BORE

- 1) Tensile Yield
 - 2) Elongation
 - 3) Charpy Test
 - d. Hydrostatic Proof Test
 - 1) Chart Recorder Graph
 - 2) Proof Test Pressure
 - e. Annealing
 - 1) Annealing Furnace Number
 - 2) Horizontal Continuous Annealing Ovens, Record Pipe Flow Through Speeds
 - 3) Horizontal Annealing Ovens, Record Pipe Rotation Speeds
 - 4) Vertical Stationary Annealing Ovens, Record Position of Pipe in Oven
 - 5) Chart Recorder Graph of Time and Temperatures During Annealing Process
 - f. Pipe Weight
 - g. Lining/Coating/Finishing
 - 1) Cement Analysis
 - 2) Sand Cement Ratio
 - 3) Curing Temperature and Humidity Records
3. Prior to the start of pipe manufacture, the independent testing agency shall review all calibration certifications for all measuring instruments (e.g., weight scales, tape measures, dial gauge indicators, tensile tester load cells, etc.) used to ensure the quality of the pipe and if necessary perform certification tests in accordance with the National Institute of Standards and Technology. The independent testing agency shall verify that written procedures and job training records are available for operations personnel for each production operation, including but not limited to raw material processing, melting, pipe casting, annealing, testing and inspection, lining, coating, etc. At all times the independent inspection agency shall verify compliance with these written procedures and these specifications.
4. During pipe manufacture the independent inspection agency shall provide adequate qualified personnel to facilitate a thorough and complete observation of the pipe's production from raw materials through final shipment. The independent inspection agency shall observe, review, and document all tests required by these specifications and AWWA/ANSI C151/A21.51 as performed by the manufacturer. The independent

CITY OF CALLAWAY CHERRY STREET DIRECTIONAL BORE

inspection agency shall also be responsible for performing verification tests on materials and samples to support the results of manufacturer-performed testing. The table below indicates the required tests to be performed by the MANUFACTURER and frequency of observations and re-testing for the independent testing agency.

Table No. 1

Operation Area	Required Tests	Frequency
Raw Materials	Analysis of chemical content of metallics, coke, fluxes, silicon	Review daily
Cupola	Analysis of chemical content of molten stream	Observed tests: every 30 minutes Verification tests: retest one (1) each day
	Analysis of chemical content after inoculation	Observed tests: every ladle Verification tests: retest one (1) sample out of every five (5)
Post Annealing	Visual inspection	Observed tests: every pipe
	Dimensional verification	Observed tests: every pipe Verification tests: retest one (1) pipe out of every ten (10)
	Mechanical properties verification (tensile, impact, hardness)	Observed tests: each test Verification tests: retest one (1) sample out of every ten (10)
	Microstructure	Observed tests: each test
Hydrotesting	Hydrostatic proof test	Observed tests: each pipe
Lining	Visual inspection Lining thickness testing	Observed tests: each pipe
Final Inspection	Visual inspection	Verification Tests: each pipe shall be visually inspected and stamped with the inspector stamp

The independent inspection agency shall verify that all test results of the manufacturer and those re-tests performed by the independent testing agency are

referenced to each individual pipe section for traceability in the future. This information shall be in a suitable format that, at the request of the owner or owner's engineer, may be downloaded into a spreadsheet format.

F. Factory Hydrostatic Test:

All pipe shall be subject to a factory hydrostatic test of at least 500 psi for a period of not less than 10 seconds; for 30 inches and larger the pressure will then be elevated to a peak pressure that induces a stress in the pipe wall equivalent to 75% of the minimum specified yield strength of ductile iron (42,000 psi) as calculated by the following formula:

$$p = 2f_s t$$

$$D$$

Where: p = peak hydrostatic pressure

f_s = 31,500 psi, stress in pipe wall during hydrostatic test, which shall be 0.75 times the minimum yield strength of the ductile iron in tension (42,000 psi)

t = nominal wall thickness, in.

D = outside diameter, in.

G. Affidavits:

Upon request the CONTRACTOR shall submit affidavits of compliance from the MANUFACTURER for the following:

1. Ductile iron pipe in accordance with the requirements of AWWA C151 and these specifications.
2. Cement-mortar lining of ductile iron pipe, specials and fittings in accordance with the requirements of AWWA C104 and these specifications.
3. Polyethylene encasement for ductile iron piping in accordance with AWWA C105 (if specified).
4. Rubber gasket joints for ductile iron pressure pipe and fittings in accordance with the requirements of AWWA C111 and these specifications.

5. Charpy impact testing of ductile iron used in the manufacture of pipe shall be performed in accordance with AWWA C151. The minimum corrected absorbed energy (ft.-lb.) shall be as follows:

7 ft.-lb. at 70° F + 10° F

6. Low-temperature impact tests shall be made from at least 10% of the test pipe to assure compliance.

The minimum corrected absorbed energy (ft.-lb.) shall be as follows:

3 ft-lb at -40° F(° C)

7. The affidavits of compliance shall be certified by a registered professional engineer.

PART 2 – PRODUCTS:

2.01 GENERAL:

- A. Standards: Ductile iron pipe shall conform to AWWA C151, subject to the following supplemental requirements. The pipe shall be of the diameter and class shown, shall be furnished complete with rubber gaskets as indicated in the Contract Documents, and all specials and fittings shall be provided as required under the Contract Documents. The ductile iron pipe, specials, and fittings shall be manufactured or supplied by American Ductile Iron Pipe (a division of American Cast Iron Pipe Company, Birmingham, Alabama) or pre-approved equal.
- B. Markings: Upon request, the CONTRACTOR shall require the MANUFACTURER to legibly mark specials in accordance with the laying schedule and marking diagram.
- C. Laying Lengths: Pipe laying lengths shall be provided in 20-foot nominal lengths with allowable trim pipe lengths in accordance with AWWA C151 and special shorter lengths provided as required by the Drawings.

2.02 PIPE DESIGN:

A. Design Parameters:

All ductile iron pipe shall be designed and manufactured in accordance with AWWA C150 and AWWA C151, respectively, for the following minimum operating conditions:

1. The minimum internal design pressure shall be 150 psi with a 100-psi surge allowance, with a safety factor of 2, for a total internal design pressure of 500 psi. No reduction of safety factor for transient pressures

shall be allowed.

Commentary: Higher working pressures and/or transient pressures must be specified (substituted) in the above paragraph when applicable to a specific project.

2. The external loads design criteria shall be a minimum of 4' depth of cover at 120 lbs. per cubic feet soil weight and live load based on one AASHTO H-20 truck load. The thickness design of ductile iron pipe shall be in accordance with AWWA C150.

Commentary: Minimum depth of soil cover as stated in the above paragraph may be revised for specific project requirements and local practices.

3. The horizontal deflection of cement-mortar lined ductile iron pipe resulting from external load conditions shall not exceed 3% of the pipe diameter.

4. The pipe trench, per AWWA C150, for design purposes shall be:

Option A: Laying condition Type 1 – Flat-bottom trench. Loose backfill. Commentary: For 14" and larger pipe, consideration should be given to the use of laying conditions other than Type 1 (Option A).

Option B: Laying condition Type 2 – Flat-bottom trench. Backfill lightly consolidated to centerline of pipe.

Option C: Laying condition Type 3 - Pipe bedded in 4" minimum loose soil. Backfill lightly consolidated to top of pipe.

Option D: Laying condition Type 4 – Pipe bedded in sand, gravel or crushed stone to depth of 1/8 pipe diameter, 4" minimum. Backfill compacted to top of pipe. (Approximately 80% Standard Proctor, AASHTO T-99.)

Option E: Laying condition Type 5 – Pipe bedded to its centerline in compacted granular material, 4" minimum under pipe. Compacted granular or select material to top of pipe. (Approximately 90% Standard Proctor, AASHTO T-99.)

5. For purposes of restrained joint calculations per the Ductile Iron Pipe Research Association (DIPRA) method, the soil classification* for both the native trench soil and also the backfill soil to surround the pipe shall be defined with one or more of the following options:

CITY OF CALLAWAY CHERRY STREET DIRECTIONAL BORE

Option A	Option B	Option C	Option D	Option E	Option F	Option G
Clay 1	Silt 1	Clay 2	Silt 2	Coh-gran	Sand Silt	Good Sand

* As described in DIPRA’s “Thrust Restraint Design for Ductile Iron Pipe,” latest edition.

B. Minimum Pipe Class:

Ductile iron pipe shall conform to AWWA C151. All pipe shall have a minimum pressure rating as indicated below, or higher ratings as indicated in the contract documents:

Table No. 3

Pipe Sizes (inch)	Pressure Class (psi)
4-12	350

Commentary: Table No. 3 should be revised to reflect any increase in working pressures and/or transient pressures provided in 2.2.A.1 above.

2.03 JOINT DESIGN:

A. General:

Ductile Iron Pipe and fittings shall be furnished with push-on joints, push-on restrained joints, mechanical joints, flanged joints, and grooved joints as required.

B. Push-on Joints:

Push-on joints shall conform to AWWA C111. Unless otherwise specified gasket material shall be standard styrene butadiene copolymer (SBR). Push-on joints shall be Fastite, as manufactured by American Ductile Iron Pipe, or pre-approved equal. The pressure rating for push-on joints shall be a minimum of 350 psi or the specified pressure rating of the pipe, whichever is less. Standard allowable joint deflection for 4”–30” Fastite pipe shall be 5°, for 36” Fastite pipe shall be 4°, and for 42”–64” Fastite pipe shall be 3°. Allowable deflection of American’s Fastite joint “Special Deflection Bells” for 36”–42” shall be 5° and for 48”–64” shall be 4°.

C. Restrained Joints:

Restrained joints shall be “Flex-Ring” or “Lok-Ring” restrained joints as manufactured by American Ductile Iron Pipe or pre-approved equal. Field-adaptable restraint shall be provided through the use of “Fast-Grip” or “Field Flex-Ring” as manufactured by American Ductile Iron Pipe, or other pre-approved and bolt-less, push-on restrained devices. When restrained joints require factory welding, the MANUFACTURER shall qualify all welding procedures and welders used to produce the product per the requirements of a documented quality assurance system based on ANSI/AWS D11.2. Unless otherwise specified, gasket material shall be standard styrene butadiene copolymer (SBR). Restrained joints and restrained joint pipe shall be rated for the minimum pressure shown in Table No. 4 or the specified pressure rating of the pipe, whichever is less. The MANUFACTURER shall furnish test results showing that restrained joints in the sizes specified have been successfully tested to at least twice the specified pressure rating of the joint without leakage or failure. Tests shall be performed on pipe with nominal metal thickness less than or equal to that specified for the project. Torque-activated restrained joint devices that rely on threaded bolts or set-screws for joint restraint shall not be used.

Table No. 4

RESTRAINED JOINT PRESSURE RATINGS, (psi) & ALLOWABLE JOINT DEFLECTIONS (Limited to the pressure rating of the pipe)				
JOINT SIZE	FAST-GRIP	FIELD FLEX-RING	FLEX-RING	LOK-RING
4"	350 / 5°		350 / 5°	
6"	350 / 5°		350 / 5°	
8"	350 / 5°		350 / 5°	

D. Flanged Joints – Pipe:

Candidate pipe for 4"- 54" flanged pipe thread-fabrication shall be Special Thickness Class 53 and for 60" – 64" flanged thread-fabrication shall be Pressure Class 350 ductile iron pipes, all in accordance with AWWA C115. Threaded

companion flanges for ductile iron pipe shall be ductile iron in accordance with AWWA C115, not ANSI B16.1. Bolt circle and bolt holes match those of ANSI B16.1 class 125 and ANSI B16.5 class 150 flanges. The flanges shall be rated for at least 250 psi working pressure. The threaded flanges shall be individually fitted and machine tightened on the pipe ends. Bolts, gaskets and installation shall be in accordance with AWWA C115, Appendix A requirements, and flanged gaskets shall be NSF 61 certified Toruseal® gaskets as manufactured by American Ductile Iron Pipe, with a special seal design. NSF 61 certified Toruseal® gaskets must be used for all 54" – 64" flanged piping, for all glass-lined piping, and for all buried flanged joints. Gaskets shall be full face NSF 61 certified Toruseal® design for all service installations. Gaskets for flanged ductile iron pipe must not have the larger inside diameters provided by the requirements of ANSI B16.21. Flange facing shall be smooth or with shallow serrations per AWWA C115.

Commentary: As noted in the appendices of various ANSI/AWWA standards and AWWA Manual M41, the use of flanged joints underground is generally not recommended because of the rigidity of the joint.

E. (Additional Paragraph): To ensure accountability, all flanged pipe shall be fabricated at the factory by the pipe manufacturer.

F. Flanged Joints – Fittings:

Flange fittings shall be ductile iron in accordance with AWWA C110 or AWWA C153, not ANSI B16.1. Bolt circle and bolt holes match those of ANSI B16.1 class 125 and ANSI B16.5 class 150 flanges. The flanges shall be rated for at least 250 psi working pressure. Bolts, gaskets and installation shall be in accordance with AWWA C110 or AWWA C115, Appendix A requirements, and flanged gaskets shall be NSF 61 certified Toruseal® gaskets as manufactured by American Ductile Iron Pipe, with a special seal design. NSF 61 certified Toruseal® gaskets must be used for all 54" – 64" flanged piping, for all glass-lined piping, and for all buried flanged joints. Gaskets shall be full face NSF 61 certified Toruseal® design for all service installations. Gaskets for flanged ductile iron pipe must not have the larger inside diameters provided by the requirements of ANSI B16.21. Flange facing shall be smooth or with shallow serrations per AWWA C110 or AWWA C153.

Commentary: As noted in the appendices of various ANSI/AWWA standards and AWWA Manual M41, the use of flanged joints underground is generally not recommended because of the rigidity of the joint.

G. Welded-on Thrust Collars:

Welded-on thrust collars, for wall pipe and pipe thrust restraint, shall be welded steel collars designed for the thrust generated by 250 psi working pressure with a

safety factor of at least two (2.0) against failure. Welded-on thrust collars shall be as manufactured by American Ductile Iron Pipe or pre-approved equal. The manufacturer shall qualify all welding procedures and welders per the requirements of a documented quality assurance system based on ANSI/AWS D11.2.

H. Mechanical Joints:

Mechanical joints shall conform to AWWA C111. Bolts shall be high-strength, low-alloy steel per AWWA C111. Unless otherwise specified, gasket material shall be standard styrene butadiene copolymer (SBR) per this standard.

I. Option Grooved Joints:

Unless specifically otherwise called for on the contract drawings, grooved joints shall be an approved substitute for flanged joints. Grooved pipe and groove joints shall be in accordance with AWWA C606. Rigid radius groove dimensions shall be utilized. Flexible grooves shall be provided as necessary for settlement or expansion as determined and approved by the ENGINEER and as specifically shown on the contract drawings. Gasket material shall be Grade "M" halogenated butyl. Bolts shall be heat-treated plated carbon steel, track head, conforming to the physical properties of ASTM A-183, minimum tensile strength 110,000 psi. Grooved ductile iron pipe shall be Special Thickness Class 53 for 4" – 16", Class 54 for 18", Class 55 for 20", and Class 56 for 24" – 36".

Commentary – The following table of available push-on and mechanical joint gaskets and services is to be used for selecting various gasket compounds for push-on and mechanical joints. The maximum service temperatures are based on lowest temperature rated mechanical joint applications, but shall also be suitable for push-on joint applications. The manufacturer should be consulted for higher temperature rating requirements that will generally be met by superior performance of push-on joint design.

Common Name Or Trade Name	Chemical Name	Temperature Capability	Common Uses
Plain Rubber	Styrene Butadiene (SBR)	120° F	Fresh Water, Salt Water, Sanitary Sewage
Neoprene	Polychloroprene (CR)	200° F	Fresh Water, Sewage, Outdoor Exposure

CITY OF CALLAWAY CHERRY STREET DIRECTIONAL BORE

Fluoroelastomer Fluorel Viton®	FKM	225° F	Aromatic Hydrocarbons, Gasoline, Refined Petroleum Products, most Chemicals and Solvents, High Temperature, Air
Buna-N Nitrile	Acrylonitrile Butadiene	120° F	Non-Aromatic Hydrocarbons, Petroleum Oil, Hydraulic Fluids, Fuel Oil, Fats, Oil, Grease
EPDM	Ethylene Propylene Diene Monomer	225° F	Water, Sewage, Ketones, Dilute Acids and Alkalies, Vegetable Oil, Alcohols, Outdoor Exposures, Air

2.04 FITTINGS:

A. General:

Fittings shall be ductile iron in accordance with AWWA C110, AWWA C153, or AWWA C606, latest revisions.

B. Cement Lining:

Fittings shall be internally lined with cement mortar in accordance with AWWA C104. The lining thicknesses shall be equal to or greater than those for comparable size pipe.

C. Buried Service Fittings:

Fittings, sizes 4" – 24", with push-on, restrained push-on, or mechanical joints shall be rated for 350 psi working pressure. Fittings, sizes 30" – 64", with push-on, restrained push-on, or mechanical joints shall be rated for 250 psi working pressure.

D. Aboveground Service Fittings:

Fittings, sizes 4" – 64", with flanged joints shall be rated for 250 psi working pressure. Fittings, sizes 4" – 36", with grooved joints shall be rated for 250 psi working pressure. Grooved couplings shall be rated for 250 psi working pressure for 4" – 18" and 150 psi working pressure for 20" – 36".

Commentary: Flanged joints for 12” and smaller sizes may be rated for 350 psi when used with AMERICAN NSF 61 certified Toruseal® gaskets.

2.05 WELDED-ON OUTLETS:

A. Outlet Size and Parent Pipe Size:

Welded-on outlets shall be limited to branch outlets having a nominal diameter not greater than 70% of the nominal diameter of the main line pipe or 36-inch, whichever is smaller (see Table No. 1), with all fabrications subject to further requirements of the following specification with regard to design and manufacture. The MANUFACTURER shall have the capability to furnish welded-on outlets as a radial (tee) outlet, tangential outlet, or lateral outlet fabricated at a specific angle to the main line pipe (in 15° increments between 45° and 90° from the axis of the main line pipe), as indicated on the drawings. Welded-on outlets shall be fabricated by the pipe manufacture at the same facility where the pipe is produced. The pipe manufacturer shall have a minimum of 5 years experience in the fabrication and testing of outlets of similar size and configuration.

Table No. 5

Main Line Nominal Diameter Versus Maximum Nominal Branch Outlet Diameter				
Main Line Nominal Dia.	Branch Outlet Nominal Dia.		Main Line Nominal Dia.	Branch Outlet Nominal Dia.
10”	6”		30”	20”
12”	8”		36”	24”

B. Outlet Joint Types:

The joints on welded-on branch outlets shall meet, where applicable, the requirements of AWWA C111 and/or AWWA C115.

C. Design:

1. The pipe wall thickness and weld reinforcement design for welded-on outlet fabrications shall be based on a method similar to that which is described in Section 13 of AWWA Manual M11 for similar welded outlets on steel pipe (which in turn refers to Section VIII of the ASME Unfired Pressure Vessel Code for design method details). Reinforcing welds shall be placed using Ni-Rod FC 55® cored wire, Stooddy Castweld Ni 55-0 cored wire, or Ni-Rod 55® electrodes manufactured by INCO Alloys (or an electrode with equivalent performance properties). Carbon steel electrodes are not acceptable. Upon request, the MANUFACTURER shall provide test results indicating typical physical properties of the utilized weld material (an all-weld sample), as well as typical physical properties from transverse tensile and impact specimens machined from butt-weld joined ductile iron pipe coupons to show the suitability or equivalence of the electrodes used.
2. Parent pipe and branch outlet candidate pipe shall be centrifugally cast ductile iron pipe designed in accordance with AWWA C150 and manufactured in accordance with AWWA C151. Minimum classes for parent and outlet pipe shall be: for sizes 4- through 54-inch, Special Thickness Class 53; for sizes 60- through 64-inch, Pressure Class 350.
3. All welded-on outlets 6- through 30-inch shall be rated for a working pressure of 250 psi. Welded-on outlets 36-inches and larger shall be rated for 200 psi. Welded-on outlets of all diameters and configurations must have a minimum safety factor of 2.5 based on proof of design hydrostatic test results. The MANUFACTURER shall, at the request of the OWNER or OWNER's ENGINEER, provide representative proof test data confirming the design, hydrostatic test results, and safety factors.
4. Prior to the application of any coating or lining in the outlet area, all weldments for branch outlets to be supplied on this project shall be subjected to an air pressure test of at least 15 psi. Air leakage is not acceptable. Any leakage shall be detected by applying an appropriate foaming solution to the entire exterior surface of the weldment and adjoining pipe edges or by immersing the entire area in a vessel of water and visually inspecting the weld surface for the presence of air bubbles. Any weldment that shows any signs of leakage shall be repaired and re-tested in accordance with the MANUFACTURERS' written procedures.

D. Quality Assurance:

1. The MANUFACTURER shall have a fully documented welding quality assurance system and maintain resident quality assurance records based on ANSI/AWS D11.2, the Guide for Welding Iron Castings.

The MANUFACTURER shall maintain appropriate welding procedure specification (WPS), procedure qualification (PQR), and welder performance qualification test (WPQR) records as well as appropriate air test logs documenting air leakage tests on all welded on outlet pipes furnished to the project. The MANUFACTURER shall have ISO 9001 or 9002 registration.

2. Prior to the start of manufacturing, any proposed MANUFACTURER not meeting ISO 9001 or 9002 registration requirements shall submit to the OWNER or OWNER's ENGINEER the name of an Independent Inspection Agency and the agency's qualifications. Submitted qualifications shall include but are not limited to the following:
 - a. List of project references for projects of similar type and size
 - b. Resumes for inspection and testing personnel
 - c. Capacities for chemical and mechanical testing of material specimens
 - d. Frequencies for all instrument and testing equipment certifications
3. The independent inspection agency shall be responsible for all of the following:
 - a. Verify compliance to written welding procedures, specification (WPS), and procedure qualification (PQR).
 - b. Verify qualification of all welders (WPQR) per ANSI/AWS D11.2 criteria.
 - c. Document use of Ni-Rod FC 55 cored wire or Ni-Rod 55 electrodes manufactured by INCO Alloys, Stoodly Cast-Weld 55-0 cored wire, or an electrode with equivalent performance properties. The independent testing agency shall provide test results indicating typical physical properties of the utilized weld material (an all-weld sample), as well as typical physical properties from transverse tensile and impact specimens machined from butt-weld joined ductile iron pipe coupons to show the suitability or equivalence of the electrodes used.
 - d. Witness and document all air testing of outlet welds.

2.06 CEMENT-MORTAR LINING

A. Cement-Mortar Lining for Shop Application:

Except otherwise provided herein, interior surfaces of all ductile iron pipe, fittings, and specials shall be cleaned and lined in the shop with a standard thickness cement-mortar lining applied in conformity with AWWA C104, Portland cement mortar. Every precaution shall be taken to prevent damage to the lining. If lining is damaged or found faulty at delivery site, the damaged or unsatisfactory portions shall be repaired or replaced with lining conforming to these Specifications.

B. Lining Thickness:

The minimum lining thickness shall be as follows:

Table No. 6

Nominal Diameter (in)	Pipe	Minimum Thickness (in)	Lining
3-12		1/16	

C. Seal Coat or Non-Seal Coat Cement-Mortar Lining:

General:

Ductile iron pipe shall be internally lined with cement-mortar lining in accordance with AWWA C104, by a high speed, centrifugal process. The quality system of the manufacturer shall be registered to an ISO 9000 quality standard by an accredited registrar. Grinding of linings shall not be allowed. The finished cement lining shall be uniformly smooth. In addition to complying with AWWA C104, the linings shall also comply with the following additional requirements:

Material:

The cement used shall be a Portland Cement. Sand shall consist of inert, hard, strong, and durable silica grains. The water used in the cement mortar shall be potable, and free from injurious quantities of organic matter, alkali, salt or other impurities that might reduce the strength, durability, or other desirable qualities of the lining. All material in contact with water shall be certified to meet the requirements of ANSI/NSF Standard 61. The cement mortar shall contain not less than one part of cement to two parts of sand, by volume. The Epoxy Liner to be used for all fittings shall be Protecto 401 by Vulcan Painters Birmingham,

Alabama or Permite 9043, Type II Glass Filled Epoxy by Permite Corporation, Atlanta, Georgia.

Lining Thickness:

Cement lining thicknesses shall be per AWWA C104 either single or double thickness and as shown in Table No. 6.

Commentary: For special service conditions, greater lining thicknesses may be furnished. Consult ACIPCO for specific capabilities.

Surface Preparation:

All surfaces to be mortar lined shall be cleaned as necessary to remove foreign matter that could interfere with the adherence of the cement mortar or protrude through the lining.

Lining Equipment and Process:

Linings shall be manufactured using centrifugal pipe rotational equipment capable of sufficient rotation speed to sustain 60 G to 100 G of compaction force. Simultaneous controlled vibration shall be applied to the pipe during high-speed rotation to produce a lining of such high density and firm compaction that the laitance can be washed from the surface of the lining immediately after consolidation. Upon request, the MANUFACTURER shall submit an affidavit of compliance certified by a registered professional engineer that the linings have been applied according to these specifications. The mortar shall be mixed in batches. The amount of cement and sand entering into each batch shall be measured by weight. The quantity of mixing water entering into each batch shall be measured automatically by an adjustable device, or it shall be otherwise measured to ensure that the correct quantity of water is being added.

Washing and Finish:

After the mortar has been distributed, the rotational speed and vibration shall be increased to produce a mortar lining with a uniformly smooth, firm surface. Immediately after lining, the surface of the lining shall be flushed with a large volume of water to remove excess laitance.

Curing:

Cement-mortar linings shall be lined and stored in a building with controlled atmosphere for a minimum of 18 hours. Linings shall be furnished standard without seal coat.

Repairs: All repairs of handling or other damage shall be made in accordance with the recommendations of the MANUFACTURER and shall be reasonably smooth and may not project into the waterway.

2.07 OPTION SEWER OR SPECIAL SERVICE - INTERIOR LINING:

Commentary:

In cases where the sewer application is non-acid forming, and the water pH is not below 6, a standard cement-mortar lining is commonly chosen as an appropriate lining. If the system is determined to be potentially acid-producing, or if the system is otherwise determined to be corrosive to cement-mortar lining, there are special service linings available from AMERICAN.

2.08 EXTERIOR COATING:

Buried Ductile Iron Pipe: The exterior of ductile iron pipe, special, and fittings shall be coated with a 1-mil asphaltic coating in accordance with AWWA C151, Section 51-9. When specified, loose polyethylene encasement shall be supplied in accordance with AWWA C105.

PART 3 – EXECUTION (NOT USED)

END OF SECTION

**SECTION 15100
VALVES AND GATES**

PART 1 - GENERAL

RELATED DOCUMENTS:

Drawings and general provisions of Contract apply to work of this section.

DESCRIPTION OF WORK:

Extent of valves and gates required by this section is indicated on drawings.

Types of valves and gates specified in this section include the following:

- Gate Valves
- Plug Valves
- Check Valves
- Tapping Valves
- Telescoping Valves
- Mud Valves
- Aluminum Slide Gates
- Stop Gates

Valves furnished as part of factory-fabricated equipment, are specified as part of equipment assembly in other.

QUALITY ASSURANCE:

Manufacturer's Qualifications: Firms regularly engaged in manufacture of valves, of types and sizes required, whose products have been in satisfactory use in similar service for not less than 3 years.

Valve Types: Provide valves of same type by same manufacturer.

Valve Identification: Provide valves with manufacturer's name (or trademark) and pressure rating clearly marked on valve body.

Codes and Standards:

ANSI Compliance: For face-to-face and end-to-end dimensions of flanged or welded-end valve bodies, comply with ANSI B16.10 "Face to Face and End-to-End Dimensions of Ferrous Valves".

UL and FM Compliance: Provide valves used in fire protection piping, which are UL-listed and FM approved.

SUBMITTALS:

Product Data: Submit manufacturer's technical product data, including installation instructions for each type of valve. Include pressure drop curve or chart for each type and size of valve. Submit valve schedule showing manufacturer's figure number, size, location, and valve features for each required valve.

Shop Drawings: Submit manufacturer's assembly-type (exploded view) shop drawings for each type of valve, indicating dimensions, weights, materials, and methods of assembly of components.

Maintenance Data: Submit maintenance data and spare parts lists for each type of valve. Include this data, product data, and shop drawings in Maintenance Manual.

PART 2 - PRODUCTS

VALVES:

General: Provide factory-fabricated valves recommended by manufacturer for use in service indicated. Provide valves of types and pressure ratings indicated. Provide proper selection as determined by Installer to comply with installation requirements. Provide end connections which properly mate with pipe, tube, and equipment connections. Where more than one type is indicated, selection is Installer's option.

Pressure sewer shutoff valves are to be full diameter opening and are to be rated for 250 pounds per square inch (psi) minimum.

Buried Valves: Provide 2" square nut operator. For quarter-turn valves 8" and larger, provide gear operator also. Provide one (1) valve key fabricated of carbon steel of suitable length for each four (4) valves of suitable strength.

Exposed Valves: Provide handwheels for all valves except quarter-turn valves, 6" and smaller. Provide lever handle for quarter-turn valves 6" and smaller. Provide one (1) lever handle for each valve pit.

GATE VALVES:

Three Inches and Smaller: Bronze construction with threaded ends or fanged ends.

Over Three Inches: All gate over three inches shall be of the iron body, non-rising bronze stem resilient seat wedge type with fanged, mechanical joint or spigot ends, depending on installation,

furnished with all necessary joint materials. Flanged gate valves shall be provided with 125 lb. American Standard flanges. Valves shall conform to AWWA Specifications C509-80.

Gate valves shall be M & H Valve Co., AWWA C 509, resilient seated gate valve or approved equal.

PLUG VALVES:

Valves shall be of the non-lubricated eccentric type with resilient seat seal unless otherwise specified and shall be furnished with end connections as shown on the plans. Flanged valves shall have flanges in full compliance to ANSI B16.1 Class 125 Standards, including facing, drilling and thickness. Face to face dimensions of flanged valves through 12" size shall be that of standard gate valves. Mechanical joint ends shall be in full conformance to ANSI Standard A21.11.

Port areas for all valves shall be at least 80% of full pipe area.

Valve bodies shall be of ASTM A-126 Class B, cast iron. All exposed nuts, bolts, springs, washers, etc., shall be zinc plated. Resilient seat seals shall be of Buna-N or Neoprene, suitable for use in sewage service.

Seats shall be non-metallic with seat coating thermally bonded and in full conformance to AWWA Standard C550. Valves shall be furnished with permanent corrosion resistant bearing surfaces in the upper and lower journals design to withstand full rated bearing loads and provide long life in sewage service. Valves furnished shall have their internal wetted surfaces protected by nonmetallic coatings factory applied, thermally bonded and in full conformance to AWWA Standard C550.

Nominal valve pressure ratings, body flanges and wall thicknesses shall be in full conformance to ANSI B16.1-1975. Valves shall seal leak-tight against full rated pressure in both directions. Valve seats shall be tested and provide leak-tight shut-off to 175 psi for valves 14" and larger, with pressure in each direction. A hydrostatic test at twice rating shall be performed with plug open to demonstrate overall pressure envelope integrity.

Manual valves shall have lever or gear actuators and tee wrenches, extension stems, floorstands, etc., as indicated on the plans. All manual valves 8" and larger shall be equipped with handwheel actuators. All gearing shall be fully enclosed in a suitable housing and be suitable for running in a lubricant with seals provided on all shafts to prevent entry of dirt and water into the actuator. Actuators shall provide clear indication of valve position. A suitable stop shall be set to provide water tight shut off in the closed position at full rated pressure. All exposed nuts, bolts and washers shall be zinc plated.

Valve actuators for buried or submerged service shall have seals on all shafts and gaskets on the valve and actuator covers to prevent the entry of water. Actuator mounting brackets for buried or submerged service shall be totally enclosed and shall have gasket seals. All exposed nuts, bolts, springs and washers used in buried service shall be electro plated steel.

CITY OF CALLAWAY CHERRY STREET DIRECTIONAL BORE

Valves and actuators shall be as manufactured by DeZurik, Valmatic, M & H, or approved equal.

CHECK VALVES:

Over Three Inches: The check valve over three inches shall be iron-body, bronze-mounted, spring and lever with flanged ends, except as specified herein. All working parts shall be spring-loaded to prevent slamming. The check valves shall be M & H 259 - lever/spring or approved equal.

Under Three Inches: Check valves under three inches shall be screwed or flanged ends, bronze-body, silent check valves as manufactured by Crane Co., No. 37, or approved equal.

FLUSHING HYDRANTS:

Flushing hydrants shall be 2" post-type with one hose nozzle, Aquarius One-O-Two HH 2" as manufactured by Gill Industries, Pensacola, Florida, or approved equal.

TAPPING VALVE AND SLEEVE:

Tapping valves and sleeves shall be ductile iron and used for tie-ins at the locations and of the size shown on the construction plans. The tapping sleeve shall be a full bolt around and shall have a flanged outlet. The tapping valve shall be a flanged mechanical joint valve. Valves shall be M & H Style 3751 or approved equal. The installation of the tapping sleeve shall be on a clean surface and shall have a minimum of 12 pipe diameters to the nearest existing joint. The tapping valve and sleeve shall be mounted and the wet tap made in accordance with the manufacturer's recommendation. The tapping sleeve shall be as manufactured by Ford (FTS coated) or approved equal.

TELESCOPING VALVES:

Telescoping Valve(s) shall be as manufactured by Vulcan Industries, Waterman Industries, or other prior approved supplier of such equipment.

The telescoping valves described in this specification shall be manufactured with new components of the highest quality available. The following codes and standards shall apply wherever applicable.

NEMA - NATIONAL ELECTRICAL MANUFACTURERS ASSOCIATION
CEMA - CANADIAN ELECTRICAL MANUFACTURERS ASSOCIATION
ASTM - AMERICAN SOCIETY FOR TESTING AND MATERIALS
AGMA - AMERICAN GEAR MANUFACTURER ASSOCIATION
ANSI - AMERICAN NATIONAL STANDARD INSTITUTE

CITY OF CALLAWAY CHERRY STREET DIRECTIONAL BORE

Valves shall consist of type (RS-rising stem)(NRS-non-rising stem)(RP-rack and pinion) floorstands. Valves shall have travel as shown on drawings. For greater than 4'0" travel on NRS valves, indicator shall be reduced to ½ of travel. On type RS or NRS, valve stem and nut shall be made of brass and shall have Acme thread (4" through 8" shall be 1" diameter), (10" through 16" shall be 1" diameter), (18" through 24" shall be 1-1/4" diameter). All assembly bolts shall be stainless steel.

Floorstands shall be fabricated from 304 Stainless Steel. Handwheels shall be (Cast Alum). All extension stems shall be Schedule 40 stainless steel pipe and terminate at the tube bracket with 6" of thread for field adjustment and be fastened to bracket with double stainless steel nuts and lock washers.

Telescoping tube shall be manufactured from stainless steel and shall be rolled and smooth seam weld 12 gauge stainless steel. Tubes shall be at least 6" longer than travel. Tube bail shall be fabricated stainless steel channel.

Indicator shall be furnished on all units and shall be as follows:

(RS) Clear plastic stem covers with rule scale.

A galvanized steel mating flange not more than ½" larger diameter than the O.D. of slip tube shall be furnished with 3/8" thick neoprene gasket (receiving pipe and flange by others).

Options:

- a. V-notch weirs shall be furnished on opposite sides of tube and shall be (2-1/2" 90 degree).
- b. Scum baffle shall be furnished on tube and shall be 10" high and have 4" clearance between tube and baffle. Baffle shall be 16 gauge stainless steel and held in place by 1/4" x 2" stainless steel bail.

MUD VALVE:

Mud valve shall be of the heavy duty flange type with rising stems. Frame, cover, yoke and stem extension connection shall be cast iron. Stems shall be brass or stainless steel. Lift nuts shall be bronze.

Seating surfaces are to be bronze and flat configuration. Flange drilling on frame will be suitable for mounting to flange per ASA-B-16.1 (125 lbs. drilling).

Gate will be operated by a Tee handle on a standard AWWA 2" valve nut or with stainless steel stem extension to the height required.

When shown, pedestal lifts, stem guides, and wall brackets will be furnished by the manufacturer of the mud valve to make a complete and operable unit.

On rising stem valves, stem guides shall be provided such that the L/r ratio of the unsupported part of the stem shall not exceed 200.

Paint will be as shown under painting specifications.

Valves and accessories shall be Waterman Model MV-11 or approved equal.

ALUMINUM SLIDE GATES:

Aluminum Slide Gates, where shown on the plans or indicated in the specifications shall be Model AC-31 Aluminum Slide Gates with resilient seal as manufactured by Waterman Industries, Inc. or equal.

The gates will be self-contained, rising stem of the flange design with drilling suitable for attachment to 25 or 125 lb. ASI companion flange.

Guide frames shall be of extruded aluminum shape, of sufficient section to carry the operating forces of the gate, and shall have UHMW polyethylene inserts on which the slide assembly travels to minimize friction. A spigot ring will be welded to the guides and have a seating surface at minimum 1-1/2 degree angle to which a resilient bulb seal shall be attached or held in place by a substantial section ring.

Dual Headrails (Yokes) shall be welded to the guide rails and so positioned that the slide is removable from the gate. The slide shall be aluminum plate suitable reinforced with extruded structural shapes for the head requirements specified and will not deflect more than 1/360 of the gate width under the design head. Suitable side guides will be welded to the slide, which will travel within the guides, and place the cover in an angle corresponding to the seat surface of the guide frame assembly. A rising stainless steel stem having modified acme type threads shall attach to the slide with a clevis and pin arrangement.

The stem will be designed to have a L/r of 200 or less and to withstand in compression at least twice the rated output of the lift at 40 lb. pull. A suitable handwheel or gear type operator should be mounted on the headrails (yoke) of the gate and will require a maximum 40 lb. pull on the handwheel rim or crank handle to operate the gate.

Flatback gates shall be attached to headwalls with anchor bolts or expansion anchors. Gates shall be installed on the anchors with nuts both behind and on the flange face so as to position the gate without stress or distortion. See manufacturer's installation instructions. Sealing between headwall and gate flange will be by dry-pack non-shrink grout or other suitable mastic sealant.

Spigotback gates will be attached to corrugated metal pipe by field drilling the pipe with 7/16" holes and secured with 3/8" stainless steel bolts, maximum spacing to be 8" on circumference of pipe. Sealing between pipe and gate will be made with suitable mastic sealing material to assure water tightness at this joint.

The gate, when installed, shall have no more than 0.05 gpm leakage per foot of sealing periphery for seating or unseating heads up to 15 feet.

Aluminum and stainless steel will be mill finish. Paint for lifts will be manufacturer's standard (or prime paint as specified elsewhere).

Material:

- Aluminum Plate and Shapes - ASTM-B211 Alloy 6061-T6
- J-Bulb Seal - Neoprene ASTM-CB610-625, D-2000
- Fasteners - ASTM F593 & F594 Type 304 or 316
- Stem - ASTM A-276 Type 304 and 316
- Handwheel Lift - Cast iron ASTM A-126 CL B W/manganese bronze lift nut per ASTM B-584 alloy 865
- Enclosed Gear Lift - Cast iron ASTM A-126 CL B W/manganese bronze lift nut per ASTM B-584 alloy 865

STOP GATES:

The fabricated aluminum stop gates, where shown on the drawings or indicated in the specifications, shall be furnished with aluminum frames with the guides designed to embed in the concrete or to mount to the face of the concrete. The gates shall be manufactured by Armtec, or Engineer approved equal.

The stop gates shall be the product of a manufacturer having at least ten years experience in the design and manufacture of low leakage stop gates under similar design conditions. Stop gates that are the product of a metals fabricator will not be acceptable. All welds shall be performed by qualified, experienced welders.

Maximum allowable leakage for the stop gates shall be as per AWWA (American Water Works Association) standards.

In addition to submittal information required by other sections of these specifications, the stop gate manufacturer may be required to submit design calculations and supporting data for all gates showing stresses, loads and deflection of critical parts under the design head conditions.

The frame shall consist of 1/4" minimum thickness extruded aluminum, alloy 6061-T6. The embedded members of the extruded frame shall be at least 1/8" thickness. The guides and invert

shall be arranged for concrete embedment. An aluminum member shall be welded or bolted to the top of each frame to prevent distortion during shipment and installation. The member shall be removed by the contractor after installation. A soft closed cell neoprene gasket shall be supplied by the manufacturer for installation between the aluminum frame and the concrete wall.

The frame guides shall incorporate black UV treated low density extruded poly side seals press fitted into the extruded frame and fastened with #8 stainless steel self tapping flat head screws on both the upstream and downstream sides of the slide. Each seat/seal will be shaped to provide two bearing surfaces and two sealing edges. Neoprene seals shall be attached to the guides, if necessary, to meet leakage criteria. A removable neoprene seal shall be contained in the invert member.

The slide shall be a minimum thickness of 1/4" aluminum plate, alloy 5083 or 6061-T6. The slide shall be reinforced with stiffeners as required so that under the maximum head, the slide will not deflect more than 1/16" of its width and stress is limited to 7,000 psi. The slide shall be provided with two slotted handles for operating the stop plate from the frame.

All aluminum in contact with concrete will have a heavy shop coat of bitumastic paint.

VALVE BOXES:

Cast-iron boxes shall be provided for all underground valve installations. They shall consist of a base covering the operating nut and head of the valve, vertical shaft, at least 5-1/4 inches in diameter, and a top section extending to a point even with the finished ground surface. Provide a cast-iron cover marked "WATER" or "SEWER" as appropriate and placed concentrically over the operating nut. The valve boxes shall be Clow F-2454 screw-type valve box USF 7500 or approved equal.

VALVE FEATURES:

General: Provide valves with features indicated and, where not otherwise indicated, provide proper valve features as determined by Installer for installation requirements. Comply with ASME B31.9 for building services piping, and ASME B31.1 for power piping.

Flanged: Valve flanges complying with ANSI B16.1 (cast iron), ANSI B16.5 (steel), or ANSI B16.24 (bronze).

Threaded: Valve ends complying with ANSI B2.1.

PART 3 - EXECUTION

INSTALLATION:

General: Except as otherwise indicated, comply with the following requirements:

CITY OF CALLAWAY CHERRY STREET DIRECTIONAL BORE

Install valves where required for proper operation of piping and equipment, including valves in branch lines where necessary to isolate sections of piping. Locate valves so as to be accessible and so that separate support can be provided when necessary.

Install valves with stems pointed up, in vertical position where possible, but in no case with stems pointed downward from horizontal plane unless unavoidable. Install valve drains with hose-end adapter for each valve that must be installed with stem below horizontal plane.

Insulation: Where insulation is indicated, install extended-stem valves, arranged in proper manner to receive insulation.

ADJUSTING AND CLEANING:

Valve Adjustment: After piping systems have been tested and put into service, but before final testing, adjusting, and balancing, inspect each valve for possible leaks. Adjust or replace packing to stop leaks, replace valve if leak persists.

Cleaning: Clean factory-finished surfaces. Repair any marred or scratched surfaces with manufacturer's touch-up paint.

END OF SECTION

**SECTION 15101
VALVES AND ACCESSORIES**

PART 1 - GENERAL

1.01 SCOPE OF WORK

The CONTRACTOR shall furnish all labor, materials, equipment and incidentals required and install complete and ready for operation and test all buried and non-buried valves as shown on the Drawings and as specified herein.

1.02 SUBMITTALS

- A. Submit materials required to establish compliance with these Specifications in accordance with Section 01300. Submittals shall include the following:
 - 1. Certified drawings showing all important details of construction and dimensions.
 - 2. Descriptive literature, bulletins and/or catalogs of the equipment.
 - 3. The total weight of each item.
 - 4. A complete bill of materials.
 - 5. Additional submittal data, where noted with individual pieces of equipment.
- B. Test Reports: Provide certified hydrostatic test data, per MANUFACTURERS standard procedure or MSS-SP-61 for all valves.
- C. Certificates: For each valve specified to be manufactured, tested and/or installed in accordance with AWWA and other standards, submit an affidavit of compliance with the appropriate standards, including certified results of required tests and certification of proper installation.
- D. MANUFACTURER's Installation and Application Data
- E. Operating and Maintenance Data: Operating and maintenance instructions shall be furnished to the ENGINEER as provided in Section 01730. The instructions shall be prepared specifically for this installation and shall include all required cuts, drawings, equipment lists, descriptions and other information required to instruct operating and maintenance personnel unfamiliar with such equipment.

1.03 REFERENCE STANDARDS

A. American Society for Testing and Materials (ASTM):

1. ASTM A48 - Specification for Gray Iron Castings.
2. ASTM A126 - Specification for Gray Iron Castings for Valves, Flanges and Pipe Fittings.
3. ASTM A159 - Specification for Automotive Gray Iron Castings.
4. ASTM A240 - Standard Specification for Heat-Resisting Chromium and Chromium-Nickel Stainless Steel Plate, Sheet and Strip for Pressure Vessels.
5. ASTM A276 - Standard Specification for Stainless and Heat-Resisting Steel Bars and Shapes.
6. ASTM A436 - Specification for Austenitic Gray Iron Castings.
7. ASTM A536 - Specification for Ductile Iron Castings.
8. ASTM B30 - Specification for Copper-Base Alloys in Ingot Form.
9. ASTM B62 - Standard Specification for Composition Bronze or Ounce Metal Castings

B. American Water Works Association (AWWA):

1. AWWA C111 - Rubber-Gasket Joints for Ductile-Iron and Gray-Iron Pressure Pipe and Fittings.
2. AWWA C500 - Gate Valves, 3-in Through 48-in NPS, for Water and Sewage Systems
3. AWWA C504 - Rubber-Seated Butterfly Valves
4. AWWA C507 - Ball Valves 6-in Through 48-in
5. AWWA C508 - Swing-Check Valves for Waterworks Service, 2-in Through 24-in NPS
6. AWWA C509 - Resilient-Seated Gate Valves, 3-in Through 12-in NPS, for Water and Sewage Systems
7. AWWA C511 - Reduced Pressure Principle Backflow Prevention Assembly

CITY OF CALLAWAY CHERRY STREET DIRECTIONAL BORE

8. AWWA C540 - Power-Actuating Devices for Valves and Sluice Gates
 9. AWWA C550 - Protective Interior Coatings for Valves and Hydrants
 10. AWWA C800 - Underground Service Line Valves and Fittings
 11. AWWA C515 – Resilient Seated Valves for 14” and Larger
- C. American National Standards Institute (ANSI):
1. ANSI B2.1 - Specifications, Dimensions, Gauging for Taper and Straight Pipe Threads (except dry seals).
 2. ANSI B16.1 - Cast Iron Pipe Flange and Flanged Fittings Class 25, 125, 250 and 800
 3. ANSI B16.10 - Face-to-Face and End-to-End Dimensions of Valves
 4. ANSI B16.104 - Butterfly Valves
- D. American Iron and Steel Institute (AISI).
- E. Manufacturer’s Standardization Society of the Valve and Fittings Industry (MSS):
1. MSS-SP-61 - Pressure Testing of Steel Valves.
 2. MSS-SP-67 - Butterfly Valves.
 3. MSS-SP-70 - Cast Iron Gate Valves, Flanged and Threaded Ends.
 4. MSS-SP-71 - Cast Iron Swing Check Valves, Flanged and Threaded Ends.
 5. MSS-SP-72 - Ball Valves with Flanged or Butt-Welding Ends for General Services.
 6. MSS-SP-78 - Cast Iron Plug Valves, Flanged and Threaded Ends.
 7. MSS-SP-80 - Bronze Gate, Globe, Angle and Check Valves.
 8. MSS-SP-82 - Valve Pressure Testing Methods
 9. MSS-SP-98 - Protective Epoxy Coatings for Interior of Valves and Hydrants.
- F. National Electrical Manufacturers Association (NEMA).
- G. Underwriters Laboratories (UL).

- H. Factory Mutual Insurance (FM).
- I. Where reference is made to one of the above standards, the revision in effect at the time of bid opening shall apply.

1.04 QUALITY ASSURANCE

A. Qualifications:

- 1. Valves and appurtenances shall be products of well established firms who are fully experienced, minimum 10 years, reputable and qualified in the manufacture of the particular equipment to be furnished.
- 2. The equipment shall be designed, constructed and installed in accordance with the best practices and methods and shall comply with these Specifications as applicable.
- 3. All units of the same type shall be the product of one MANUFACTURER.

B. Certifications:

- 1. The MANUFACTURER'S shall furnish an affidavit of compliance with Standards referred to herein as specified in paragraph 1.03C.
- 2. Refer to Part 3 for testing required for certain items in addition to that required by referenced standards.

C. Provide the services of a qualified and factory-trained service representative of the MANUFACTURER to provide operational and maintenance instruction, for a one-day, eight hour period for:

- 1. Valve motor operators.
- 2. Valve hydraulic operators.
- 3. Valve pneumatic operators.
- 4. Pressure regulating valves.
- 5. Air release, air and vacuum valves.

D. Inspection of the units may also be made by the ENGINEER or other representative of the OWNER after delivery. The equipment shall be subject to rejection at any due to failure to meet any of the Specification requirements, even though submittal data may have been accepted previously. Equipment rejected after delivery shall be marked for identification and shall be removed from the job site at once.

1.05 SYSTEM DESCRIPTION

- A. All of the equipment and materials specified herein is intended to be standard for use in controlling the flow of wastewater, sludges, reclaimed water, potable water, air or chemicals, depending on the individual systems, as noted on the Drawings.
- B. Valves, appurtenances and miscellaneous items shall be installed as shown on the Drawings and as specified, so as to form complete workable systems.
- C. Unless otherwise noted all powered valve operators shall have:
 - 1. Valves smaller than 8 inches: electric operators 120V, single phase, 60 Hz.
 - 2. Valves larger than 8 inches: electric operators 480 volt, 3 phase, 60 Hz.
 - 3. Solenoid valves: 120 volt, single phase, 60 hz, NEMA 4 enclosure, continuous duty Class F coils and manual operator.
 - 4. See other paragraphs for additional requirements.
- D. Packing and Shipping:
 - 1. Care shall be taken in loading, transporting and unloading to prevent injury to the valves, appurtenances, or coatings. Equipment shall not be dropped. All valves and appurtenances shall be examined before installation and no piece shall be installed which is found to be defective. Any damage to the coatings shall be repaired as acceptable to the ENGINEER.
 - 2. Prior to shipping, the ends of all valves shall be acceptably covered to prevent entry of foreign material. Covers shall remain in place until after installation and connecting piping is completed.
 - a. All valves 3-in and larger shall be shipped and stored on site until time of use with wood or plywood covers on each valve end.
 - b. Valves smaller than 3-in shall be shipped and stored as above except that heavy cardboard covers may be used on the openings.
 - c. Rising stems and exposed stem valves shall be coated with a protective oil film which shall be maintained until the valve is installed and put into use.
 - d. Any corrosion in evidence at the time of acceptance by the OWNER shall be removed, or the valve shall be removed and replaced.

E. Storage and Protection:

Special care shall be taken to prevent plastic and similar brittle items from being directly exposed to the sun, or exposed to extremes in temperature, to prevent deformation. See the individual piping specifications and MANUFACTURER's information for further requirements.

1.06 MAINTENANCE

- A. Special tools and the MANUFACTURER's standard spare parts, if required for normal operation and maintenance, shall be supplied with equipment.
- B. Provide all special tools required for normal maintenance.
- C. Tools shall be packaged in a steel case, clearly and indelibly marked on the exterior to indicate equipment for which tools are intended.
- D. Provide to the OWNER a list of all spare and replacement parts with individual prices and location where they are available.
- E. Prices shall remain in effect for a period of not less than one year after start-up and final acceptance.

PART 2 - PRODUCTS

2.01 MATERIALS AND EQUIPMENT - GENERAL

- A. Reference is made to Division 1 for additional requirements, including nameplates, provisions for temporary pressure gages, protection against electrolysis and anchor bolts.
- B. The use of a MANUFACTURER's name and/or model or catalog number is for the purpose of establishing the standard of quality and general configuration desired.
- C. Valves and appurtenances shall be of the size shown on the Drawings or as noted and as far as possible equipment of the same type shall be identical and from one MANUFACTURER.
- D. Valves and appurtenances shall have the name of the maker, nominal size, flow directional arrows, working pressure for which they are designed and standard referenced, cast in raised letters or indelibly marked upon some appropriate part of the body.

- E. Unless otherwise noted, items shall have a minimum working pressure of 150 psi or be of the same working pressure as the pipe they connect to, whichever is higher and suitable for the pressures noted where they are installed.
- F. Joints, size and material - unless otherwise noted or required by the ENGINEER:
 - 1. Except where noted, all joints referred to herein shall be of the same type, nominal diameter, material and with a minimum rating equal to the pipe or fittings they are connected to.
 - 2. Valves and appurtenances shall be of the same nominal diameter as the pipe or fittings they are connected to.
 - 3. All valves exposed to view, or in vaults.
 - a. 3-in and smaller - threaded ends
 - b. 4-in and larger flanged ends.
- G. Provide all special adaptors as required to ensure compatibility between valves, appurtenances and adjacent pipe.
- H. Valves and actuators located outdoors but not within a building; within maximum 2-ft above liquid; in vaults; or where otherwise noted shall be especially designed for submerged service where water may completely submerge the valve and operator. All other units shall be as a minimum weather tight.

2.02 VALVE ACTUATORS - GENERAL

- A. The valve MANUFACTURER shall supply and integrally, rigidly mount all actuators, including any type of manual or powered actuators, on valves at the factory. The valves and their individual actuators shall be shipped as a unit.
- B. Unless otherwise noted, valves shall be manually actuated; nonburied valves shall have an operating wheel, handle or lever mounted on the operator; buried valves and those with operating nuts shall have a non-rising stem with an AWWA 2-in nut. At least two tee handles shall be provided for all operating nuts.
- C. Except as otherwise shown on the Drawings or specified herein, all valves 3-in diameter or larger, with the valve center line located 7-ft or more above the operating floor, shall be provided with chain wheel operators complete with chain guides and hot dipped galvanized steel chain, which loop within 4-ft of the operating floor.

- D. All actuators shall be capable of moving the valve from the full open to full close position and in reverse and holding the valve at any position part way between full open or closed.
- E. Each operating device shall have cast on it the word "OPEN" and an arrow indicating the direction of operation.
- F. Floor boxes for operating nuts recessed in concrete shall be standard cast iron type, cast-in-place, with fastening top by Clow or equal.
- G. Stem guides shall be of the adjustable wall bracket type, bronze bushed, with maximum spacing of 10-ft as manufactured by Clow; Rodney Hunt or equal. Extended operating nuts and/or stems shall have universal joints and pin couplings, if longer than 10-ft and a rating of at least five times the maximum operating torque. Stem adaptors shall be provided.
- H. Where required by the installation, or as specified, provide the following: extended stem; floor stand and handwheel; position indicator and etched or cast arrow to show direction of rotation to open the valve; resilient seal around stem penetration of slab.

2.03 BUTTERFLY VALVES FOR FLUID SERVICE (METAL BODY)

- A. Butterfly valves and operators up to 72 inches diameter shall conform to AWWA C504, Class 150B, except as hereinafter specified. The MANUFACTURER shall submit an affidavit of compliance stating that the valves have been manufactured and tested in accordance with AWWA C504 and specifically listing all exceptions. Valves shall have a minimum 150 psi pressure rating or higher as noted on the Drawings or in the Specifications and be manufactured by Val-Matic Pratt, Dezurik or equal.
- B. Butterfly valves for above grade shall be flanged end with face to face dimensions in accordance with Table 2 of AWWA C504 Standard for short-body valve. All valves for dead end shut off service shall be flanged type. Butterfly valves for buried service shall be mechanical joint ends conforming to ANSI/AWWA C111/A21.11 and shall be mechanically restrained with Megalug Series 1100 or ENGINEER approved equal.
- C. Valve seats shall be full resilient seats retained in the body or on the disc edge in accordance with AWWA C504. Valve discs shall be constructed of cast iron, ASTM A48, Class 40; Ni-resist, ASTM A126, Class B; or ductile iron, ASTM A536, Grade 65-45-12.
 - 1. For valves 24-inch in diameter and larger, when the resilient seats are attached to the body, discs shall have Type 316 stainless steel seating edges. When the resilient seat is attached to the disc, it shall be fastened with a one piece Type 316 stainless steel retaining ring, Type 316 stainless

steel Nylock set screws and a mating Type 316 stainless steel ring shall be installed in the valve body.

2. Resilient seats shall be Hycar or equal. Seats shall be fully adjustable and replaceable with the valves in place for all valves.
- D. The valve body shall be constructed of close grain cast iron per ASTM A126, Class B with integrally cast hubs for shaft bearing housings of the through boss-type. Permanently self-lubricating body bushings shall be provided and shall be sized to withstand bearing loads. Stuffing box of liberal dimensions shall be provided at the operator end of the vane shaft.
1. Packing shall be of the self compensating v-type. A sealing element utilizing O-rings shall also be acceptable for up to and including 24-in valves. Over 24-in, pull down seals using a square braid of graphited asbestos is an acceptable alternate.
 2. Packing shall be held in place by a bolted corrosion resistant retainer plate or gland; retainer clips are not acceptable. For 30-in or larger, use a stuffing box with follower gland.
 3. Replacement of seals, for all size butterfly valves, shall not require removal of the valve from the line. In addition adjustment or replacement of seals on valves of 30-in or larger shall not require disturbing any part of the valve or operator assembly, except any packing follower gland.
- E. The valve shaft shall be of Type 316 stainless steel and designed for both torsional and shearing stresses when the valve is operated under its greatest dynamic or seating torque. No reductions of shaft diameter will be allowed except at the operator connection. Any reduction shall have a full radius fillet.
- F. In general, the butterfly valve actuator shall conform to the requirements of AWWA C504, insofar as applicable and as herein specified.
- G. Gearing for the actuators where required shall be totally enclosed in a gear case in accordance with AWWA C504.
- H. The manual actuators shall conform to AWWA C504, insofar as applicable. Actuators shall have permanent indicators with raised or engraved marks to show position of the valve disc.

2.04 GATE VALVES (2-1/2-IN AND SMALLER)

- A. Gate valves 2-1/2-in diameter and smaller shall have flanged, screwed, or solder ends as required and shall be brass, or bronze, or Type 304 stainless steel solid wedge, union bonnet, rising-stem gate valves such as Figures 47 and 48 as manufactured by Jenkins Brothers or equal products as manufactured by Crane; Fairbanks; Lukenhiemer or equal.
- B. All water valves 2-1/2-in and 3-in unless noted otherwise, shall be brass body gates and shall be Jenkins No. 1240, or Hammond 1B-647.

2.05 GATE VALVES (3-IN AND LARGER)

A. General Requirements:

- 1. Unless otherwise specified below, these requirements shall apply to all gate valves.
- 2. Gate valves shall meet the requirements of AWWA C500 and AWWA C509 as applicable to the type of valve specified.
- 3. Buried and submerged valves shall be furnished with mechanical joints and stainless steel hardware; non-rising stem design.
- 4. Exposed valves shall be furnished with Class 125 flanged ends and hand wheel; provide valves with outside screw and yoke.
- 5. All-metal valves shall be manufactured of ASTM A536, Ductile Iron, with bronze mounting design.
- 6. Rising stem valves shall be sealed with adjustable and replaceable packing; valve design must permit packing replacement under operating system pressures with only moderate leakage.
- 7. Non-rising stem valves shall use a double O-ring stem seal, except that packing shall be used where geared operators are required.
- 8. Except as otherwise specified, valves shall be rated for the following working water pressures:

<u>Valve Size</u>	<u>Pressure (psig)</u>
3-in to 12-in	250
14-in to 20-in	250
24-in and greater	250

All valve bodies shall be hydrostatically tested to at least twice the rated working water pressure. In addition, valves shall be seat-tested, bi-directional at the rated working pressure, with seat leakage not to exceed one fluid ounce per inch of valve diameter per hour. Provide certificates of testing.

9. Flanged valves to have face-to-face dimensions per ANSI B16.1 and flanges per ANAI B16.10.
10. Exposed valves 16-in and larger to have valve by-pass.
11. All bonnet and packing gland bolts shall be zinc or cadmium electroplated steel; packing gland bolts shall have bronze nuts.
12. Exposed valves 16-in and greater indicated for horizontal stem installation shall be furnished with rollers, tracks and scrapers and enclosed bevel gear grease case.
13. Provide geared operator and chainwheel, chain and chain guides for valves with handwheel centerline more than 7-ft above operating level.
14. All valves shall be marked per AWWA Standards, including name of MANUFACTURER, valve size and working pressure and year of manufacture.
15. Unless otherwise indicated, valves 12-in and smaller shall be capable of installation in the vertical or horizontal position, sealing in both directions at the rated pressure.
16. Valve operation shall be counterclockwise for potable water; clockwise for wastewater and other non-potable waters. Provide permanent label showing "OPEN" and arrows.
17. Metal-seated valves shall be coated internally and externally with an asphaltic varnish, per AWWA C500. Resilient seated valves shall be coated, interior and exterior, with fusion bonded epoxy per AWWA C550.

B. Valve Applications:

1. Valves for Non-Potable Water Service:
 - a. Resilient seat gate valves shall be ductile iron bodied, bronze mounted, with wedge type disk, hand wheel and rubber seat. Valves shall be manufactured in accordance with AWWA C509. Valves shall be suitable for above ground service, be designed for 150 psi working pressure, shall be of O-ring type, with non-rising

stem, and opening counterclockwise. Valves shall have flanged ends. Valves shall be coated in accordance with AWWA C550.

- b. Resilient seated design manufactured by American R-B Clow, Mueller, M&H Valve Company or equal.

2. Valves for Wastewater Service (NOT USED)

3. At the CONTRACTOR's option and unless otherwise indicated, any of the listed valve styles may be used, at no additional cost to the OWNER.

C. Valve Requirements:

1. Double Disc (NOT USED)

2. Double Revolving Disc (NOT USED)

3. Solid Wedge (NOT USED)

4. Resilient Seated:

- a. Conform to AWWA C509. Also UL and FM approved.

- b. Internal and external epoxy coating of valve body, including bonnet, per AWWA C550.

- c. Gate shall be encapsulated with synthetic rubber. It shall be bonded and vulcanized in accordance with ASTM B429 Method B.

- d. No recesses in valve body.

D. Buried Valves:

1. Conform to the requirements above, except mechanical joint bell ends per AWWA C111. The valve shall be mechanically restrained with Megalug Series 1100 or ENGINEER approved equal. All exposed valve hardware (nuts, bolts, washers, etc.) including bonnet, bonnet cover, stuffing box, gear adaptor and joints shall be Type 304 stainless steel.

2. Non-rising stem design, double o-ring seals for non-gear valves and shall incorporate packing for geared valves.

3. Provide valve box, 2-in operating nut and extension stem and stem cover.

E. Tapping Valves and Sleeves:

1. Tapping valves shall comply with the same requirements as resilient seated gate valves or double revolving disc gate valves except they shall have the flanged end and port opening modified for tapping service. Valves shall be capable of passing a full nominal sized cutter without damage to the valve. The tapping sleeve shall be gray cast iron or ductile iron mechanical joint type with the outlet flange conforming to MSS-SP-60.
2. All water valves, 4-in and larger, shall be iron body gates, bronze trim, flanged ends, O.S. & Y. pattern, solid wedge, rising spindle, Jenkins No. 651, or Hammond 1R-1140.

2.06 PLUG VALVES

- A. Plug valves shall be of the offset disc type, ¼ turn, non-lubricated, serviceable (able to be repacked) under full line pressure and capable of sealing in both directions at the rated pressure. The disc shall be completely out of the flow path when open. Plug valves specified herein shall be by DeZurik, Clow, M&H, Val-Matic, or equal. All Manufacturers, named or otherwise, must comply completely with the specification.
1. For clean liquid or screened sewage, all size plug valves shall have a minimum port area of 80 percent.
 2. On sludge and scum lines, all valves 24-in and larger shall have a minimum 100 percent open port area; for all other valves, a minimum port area shall be 80 percent when measured by the percent cross-sectional area of equivalent size (nominal same diameter) pipe.
 3. All plug valves for what ever service, shall be capable of passing "pigging" cleaning equipment (using a Girard or similar cleaning pig of full nominal pipeline diameter) in either direction and MANUFACTURER shall so certify that this may be done without the use of special equipment.
- B. Valves shall be rated at minimum 175 psi W.O.G. (Water, Oil, and Gas) working pressure for sizes 4-in to 12-in inclusive and at minimum 150 psi W.O.G. working pressure for sizes 14-in and larger.
1. All plug valves under this paragraph shall be performance, leakage and hydrostatically tested in accordance with AWW A C504, except as herein modified.

2. At the above rated minimum working pressures, the valves shall be certified by the MANUFACTURER as permitting zero leakage for a period of at least one-half hour with pressure applied to the seating face.
 3. At the request of the ENGINEER, the valve MANUFACTURER may have to perform a valve seat leakage test, witnessed by the ENGINEER to prove compliance with these Specifications.
- C. Valve bodies shall be of cast iron, 30,000 psi tensile strength, ASTM A 126, Grade B, or of ductile iron, ASTM A536 and of the top entry, bolted bonnet design, cast with integral flanges conforming to the connecting piping. All exposed bolts, nuts and washers shall be zinc or cadmium-plated, except for buried or submerged valves, which shall have Type 316 stainless steel hardware.

The valve disc shall:

1. Be cast iron ASTM A 126, Grade B, or ductile iron, ASTM A536, Grade 65-45-12.
 2. Be removable without removing the valve from the line.
 3. Have an integral upper and lower shaft which shall have seals on the upper and lower journals to prevent entrance of solids into the journals.
 4. Be one piece for valves up to 14-in and maximum two piece for larger valves.
- D. Shaft bearings shall be permanently lubricated, rigidly backed TFE, stainless steel or bronze at both upper and lower stem journals. The operator shaft shall have easily replaceable seals, which shall be externally adjustable and repackable without removing the bonnet from the valve, or shall have self adjusting packing.
- E. The valve seating surface shall provide full 360 degree seating by contact of a resilient seating material on the disc mating with welded-in high nickel content overlay seating surface in the body.
1. The seating design shall be resilient and of the continuous interface type having consistent opening and closing torques and shall be non-jamming in the closed position. Screw-in seats shall not be acceptable.
 2. Discs shall have a full resilient facing of neoprene or Buna-N.
- F. The methods of mounting the actuator to the valve shall provide an air gap between the two. Actuator shall clearly indicate valve position and an adjustable stop shall be provided. Construction of actuator housing shall be semi-steel. Hardware on actuators shall be of the same materials as the valves.

- G. Unless otherwise required, due to location or operation, each valve 6-in and smaller shall be provided with its own securely attached lever. Provide adjustable limit stops for both opening and closing and a clearly marked position indicator.
- H. Plug valves shall be installed so that the direction of flow through the valve and the shaft orientation is in accordance with the MANUFACTURER's recommendations. Unless otherwise noted, shaft shall be horizontal, with plug opening up.

2.07 BALL VALVES

A. Ferrous Ball Valves:

- 1. Ball valves for mainline or water service shall be either ductile iron or carbon steel body, full bore, fire-safe, rated for a line pressure of 150 psig. Except as noted, ball valves shall comply with AWWA C507.
- 2. The design of the valve shall be such that it shall provide suitable seating in both directions. In order to determine the position of the ball within the valve (open or closed), there shall be an easily visible, permanent, indicator located conspicuously on the valve. Ball valves shall have Type 316 stainless steel seating surfaces. Seats shall be Type 304 stainless steel. The fully open port area shall be approximately 100 percent of the nominal pipe area.
- 3. Valve shafts shall be ground and polished and shall be Type 304 stainless steel. Teflon-lined bearings shall be supplied in both trunnions of the valve body.
- 4. The valves shall be constructed so that the seals, seats and balls are accessible for replacement without dismantling the piping. The valves shall not require lubrication but shall have stuffing boxes which can be packed with the valve in service without undue leakage. Ball valves shall be as manufactured by Henry Pratt Co., Aurora, IL; Williamette, Portland, or equal.
- 5. Valve actuators shall conform to AWWA C507 and as specified herein.

- B. Ball valves for water piping shall be manual or electric actuated (as shown on the Drawings), bronze, resilient seated, regular port, threaded two piece bolted body type valves. The body and cap shall be of brass, ASTM B30, the ball and stem of Type 316 stainless steel and the seats and seals of TFE. The valves shall have full floating ball and shall be non lubricated. Valve seats shall be easily accessible and replaceable. Valves shall be rated to 250 psi and shall be as manufactured by Neles-Jamesbury; WKM or equal.

2.08 CHECK VALVES

- A. Swing check valves, sizes 2-1/2 inches through 12 inches shall be spring and lever operated with bronze disc facing and flanged ends with a maximum working pressure of 175 psig and test pressure of 350 psig.
- B. Swing check valves, sizes 14 inches through 24 inches shall be spring and lever operated with bronze disc facing and flanged ends with a maximum working pressure of 150 psig and test pressure of 300 psig.
- C. Swing check valves, sizes 4 inches and smaller shall use bronze disc ASTM B584.
- D. Valves shall meet all applicable parts of ANSI/AWWA C508 Standard.
- E. Valves for above grade shall be flanged end. Flanged end dimensions and drilling shall comply with ANSI B16.1, Class 125. Swing check valves for buried service shall be mechanical joint ends.
- F. The valve body shall be constructed of ductile or cast iron per ASTM A126, Class B, or ASTM A536, bronze mounted (IBBM).
- G. Valves shall be located above grade unless otherwise noted in the Drawings and Specifications.
- H. Valves shall have an O-ring sealed stuffing box.
- I. Valves shall have adjustable spring tension to control opening and closing of the clapper.
- J. Valves shall be installed so that the direction of flow through the valve and the shaft orientation is in accordance with the MANUFACTURER'S recommendations.
- K. Swing check valves specified herein shall be by Mueller Company, Model No. 2600 for above grade installations, or ENGINEER approved equal. All Manufacturers, named or otherwise, must comply completely with the specification.

2.09 AIR RELEASE VALVES

- A. Air release valve assembly shall be furnished and installed on the reuse water transmission main as shown on the drawings.

CITY OF CALLAWAY CHERRY STREET DIRECTIONAL BORE

- B. Air release or valve assembly shall consist of a combination short body, air release-vacuum breaker valves, installed in a manhole with vented manhole cover, gate valve, fittings, tapping saddle and connecting piping to the main.
- C. Air release valves shall be installed to release any small accumulations of air, which may collect while pipe is in operation and under pressure.
- D. Air release valves on a HDPE pipe shall utilize an electrofusion corp saddle with stainless steel outlet as manufactured by Central Plastics or equal.
- E. The air release valves shall be Val-Matic Model 42 or engineer approved equal.
- F. The small orifice assembly air release valve shall automatically release air accumulations from the pipe while under positive pressure.
- G. When the valve body fills with air, the float ball shall fall to open the small orifice and exhaust the air to atmosphere.
- H. When the air has been exhausted, the float ball shall be buoyed up and tightly close the small orifice.
- I. The small orifice assembly shall be furnished with cast iron body and cover (ASTM A126-B).
- J. The float ball shall be constructed of stainless steel and attached to a stainless steel lever mechanism.
- K. A resilient, Buna-N seat shall be attached to the lever mechanism for drop-tight closure.
- L. Valves shall be corrosion resistant, suitable for reuse water transmission main application, and shall automatically function to release to the atmosphere both large and small amounts of air that accumulate in the pipeline.
- M. Once the air has been exhausted, both valves shall seal tightly to prevent liquid leakage.
- N. The valve shall also function to admit air into a line, tank, or chamber under emergency conditions or when it is being drained.
- O. The capacity and pressure rating of the valve is dependent on the diameter of the precision orifice in the cover.
- P. The Orifice Size shall be 5/32-inch. A large inlet connection is required for proper air and water exchange.
- Q. The reuse water air release valves inlet size shall be 2-inch NPT for reuse water mains.

CITY OF CALLAWAY CHERRY STREET DIRECTIONAL BORE

- R. The reuse water air release valves outlet size shall be 1/2-inch NPT for reuse water mains.
- S. The Air Release Valves shall be automatic float operated valves designed to release accumulated air from a piping system while the system is in operation and under pressure and installed in a concrete box as shown on the drawings.
- T. Box and like shall be of the necessary size to the valve.
- U. To connect the air valve, a corporation stop shall be tapped into the main using the procedures as recommended by the ductile iron pipe manufacturer.
- V. The corporation stop shall be Mueller H-10045 or approved equal.
- W. The valve body shall be threaded with NPT inlets and outlets.
- X. The body inlet connection shall be hexagonal for a wrench connection.
- Y. The valve shall have two additional NPT connections for the addition of gauges, testing and draining.
- Z. The valve body and cover shall be constructed of ASTM A126 Class B cast iron working pressures of 300 psig, with resilient seats, rubber covered floats and no levers.
- AA. The cover shall be bolted to the valve body and sealed with a flat gasket.
- BB. Resilient seats shall be replaceable and provide drop tight shut off to the full valve pressure rating.
- CC. Floats shall be unconditionally guaranteed against failure including pressure surges.
- DD. Mechanical linkage shall provide sufficient mechanical advantage so that the valve will open under full operating pressure.
- EE. The orifice, float and linkage mechanisms shall be constructed of Type 304 stainless steel.
- FF. Non-metallic floats or linkage mechanisms are not acceptable.
- GG. The manufacturer shall demonstrate a minimum of five (5) years experience in the manufacture of air valves.
- HH. The valves shall be manufactured and tested in accordance with American Water Works Association Standard (AWWA) C512.

- II. The manufacturer shall provide test certificates, dimensional drawings; parts list drawings, and operation and maintenance manuals.
- JJ. The exterior of the valve shall be coated with a universal alkyd primer.
- KK. Air Release Valves shall be as manufactured by Val-Matic Valve & Mfg. Corporation Model No. 38.6, Elmhurst, IL. USA or approved equal.

2.10 AIR/VACUUM VALVES (NORMAL OPERATION)

- A. The large orifice assembly air and vacuum valve shall automatically exhaust air from a pipeline during the initial filling of the pipeline.
- B. The large orifice assembly shall not blow shut while exhausting air, even while venting air at sonic velocity.
- C. When all air has been exhausted from the pipeline, the large orifice float ball shall be buoyed up to seat tightly against a resilient seat ring.
- D. The large orifice float ball shall remain tightly closed while the pipeline is under positive pressure.
- E. Should the pipeline pressure fall below atmospheric pressure (such as during draining or a line break), the large orifice float ball shall automatically fall away from the seat ring and permit air to enter the pipeline.
- F. The large orifice assembly shall be furnished with cast iron body and cover (ASTM A126-B).
- G. A resilient, Buna-N seat ring shall be affixed to the valve cover.
- H. The float ball shall be constructed of stainless steel with a minimum pressure rating of 1,000 psi. [The float ball shall be free floating within the valve body; guide stems, linkages or levers attached to the float are not acceptable.]
- I. Unit shall be manufactured by GA; APCO; Val-Matic or equal. Special type for use with non-clean fluids shall be provided.

2.11 COMBINATION AIR AND AIR/VACUUM OR VACUUM RELIEF VALVES

- A. Valves shall be corrosion resistant, suitable for reuse water application. Combination air valve assembly shall be furnished and installed on the reuse water transmission main as shown on the drawings.
- B. Combination air valve assembly shall consist of a single body, combination air release and air/vacuum valves, installed in a manhole with vented manhole cover, gate valve, fittings, tapping saddle and connecting piping to the reuse water main. Manhole and like shall be of the necessary size to the valve.

CITY OF CALLAWAY CHERRY STREET DIRECTIONAL BORE

- C. Combination air valves shall be automatic float operated valves and installed to release large accumulations of air during the filling of the piping system and close upon liquid entry.
- D. The valve shall open during draining or if a negative pressure occurs.
- E. The valve shall also release accumulated from a piping system while the system is in operation and under pressure.
- F. The capacity and pressure rating of the valve is dependent on the diameter of the precision orifice in the cover.
- G. The large orifice diameter shall be 2-inch and the air release orifice shall be 3/32.”
- H. A large inlet connection is required for proper air and water exchange.
- I. The reuse water combination air valves inlet and outlet size shall be 2-inch NPT.
- J. To connect the air valve, a corporation stop shall be tapped into the main using the procedures as recommended by the ductile iron pipe manufacturer.
- K. The corporation stop shall be Mueller H-10045 or approved equal.
- L. The single body valve shall be threaded with NPT inlets and outlets. The NPT inlets and outlets shall be equal to the nominal valve size.
- M. The body inlet connection shall be hexagonal for a wrench connection.
- N. The valve shall have two additional NPT connections for the addition of gauges, testing and draining.
- O. The combination air valve shall be furnished with cast iron body and cover (ASTM A126-B).
- P. The float ball, guide shafts, and bushings shall be constructed of type 304 stainless steel and attached to a stainless steel lever mechanism.
- Q. A resilient, Buna-N seat shall be attached to the lever mechanism for drop-tight closure. Non-metallic floats or linkage mechanisms are not acceptable.
- R. Single body combination valves shall have an expanded outlet to provide full are around the guide mechanism.
- S. The valve shall have a double guided plug and an adjustable threaded orifice.
- T. The plug shall be protected against direct water impact by an internal baffle.
- U. The plug shall have a precision orifice drilled through the center stem.

- V. The cover shall be bolted to the valve body and sealed with a flat gasket.
- W. Resilient seats shall be replaceable and provide drop tight shut off to the full valve pressure rating.
- X. Floats shall be unconditionally guaranteed against failure including pressure surges.
- Y. Mechanical linkage shall provide sufficient mechanical advantage so that the valve will open under full operating pressure.
- Z. The exterior of the valve shall be coated with a universal alkyd primer.
- AA. The manufacturer shall demonstrate a minimum of five- (5) years experience in the manufacture of air valves.
- BB. The valves shall be manufactured and tested in accordance with American Water Works Association Standard (AWWA) C512.
- CC. The manufacturer shall provide test certificates, dimensional drawings; parts list drawings, and operation and maintenance manuals.
- DD. Air Valves shall be as manufactured by Val-Matic Valve & Mfg. Corporation engineer approved equal.

2.12 PRESSURE RELIEF VALVES FOR AIR

- A. Pressure relief valves shall be designed for air and built to ASME standards and shall be National Board Certified.
- B. The Valve shall have a one-piece brass body, chrome steel ball on brass seat, silicone rubber seal, and stainless steel spring.
- C. The Preset pressure limit of 100 psi shall be tested and sealed by the manufacturer.
- D. The pressure relief valve shall have a bubble tight seal within 10% of set pressure.
- E. The pressure relief valve shall be manufactured by Control Devices, Inc. or ENGINEERED approved equal.

2.13 INSULATING FITTINGS

Fittings shall be of type to provide control of electrolysis and equal to "Dielectric" as manufactured by Watts Regulator Co., or equal.

2.14 SURFACE PREPARATION AND SHOP COATINGS

- A. Notwithstanding any of these Specifications, all coatings and lubricants in contact with non-potable water shall be certified as acceptable for use with that fluid.
- B. In case of a conflict, the requirements of this Section govern.
- C. If the MANUFACTURER's requirement is not to require finished coating on any interior surfaces, then MANUFACTURER shall so state and no interior finish coating will be required, if acceptable to the ENGINEER.
- D. The exterior surface of various parts of valves, operators, floor-stands and miscellaneous piping shall be thoroughly cleaned of all scale, dirt, grease or other foreign matter and thereafter one shop coat of an approved rust-inhibitive primer such as Inertol Primer No. 621 shall be applied in accordance with the instructions of the paint MANUFACTURER or other primer compatible with the finish coat provided.
- E. Unless otherwise noted, interior ferrous surfaces of all valves shall be given a shop finish of an asphalt varnish conforming to AWWA C509, (except mounting faces/surfaces) or epoxy AWWA C550 with a minimum thickness of 4 mil.
- F. Ferrous surfaces obviously not to be painted shall be given a shop coat of grease or other suitable rust-resistant coating.
- G. Mounting surfaces shall be especially coated with a rust preventative.
- H. Special care shall be taken to protect uncoated items and plastic items, especially from environmental damage.

2.15 FACTORY INSPECTION, TESTING AND CORRECTION OF DEFICIENCIES

- A. Factory inspection, testing and correction of deficiencies shall be done in accordance with the referenced Standards and as noted herein.
- B. See Division 1 for additional requirements. Also refer to Part 1 of this Section, especially for required submission of test data to the ENGINEER.
- C. In addition to all tests required by the referenced Standards, the following shall also be factory tested:
 - 1. Pressure regulating valves shall be factory tested at the specified pressures and flows.
 - 2. The non-cavitating butterfly valves, to demonstrate its non-cavitating capabilities.
 - 3. All types of air and vacuum valves.

2.16 VALVE BOXES

- A. Valve boxes shall be provided for all buried valves.
- B. Valve boxes shall consist of cast iron base and adjustable top section with cover, which shall be marked "Water, Sewer, or Reuse."
- C. Cast iron extensions shall be provided as required to meet grade.

PART 3 - EXECUTION

3.01 INSTALLATION - GENERAL

- A. All valves and appurtenances shall be installed per the MANUFACTURER's instructions in the locations shown, true to alignment and rigidly supported.
- B. Any damage to the above items shall be repaired to the satisfaction of the ENGINEER before they are installed.
- C. Install all brackets, extension rods, guides, the various types of operators and appurtenances as shown on the Drawings, or otherwise required.
- D. Before setting these items, the CONTRACTOR shall check all Drawings and figures which have a direct bearing on their location.
- E. The CONTRACTOR shall be responsible for the proper location of valves and appurtenances during the construction of the Work.
- F. All materials shall be carefully inspected for defects in construction and materials. All debris and foreign material shall be cleaned out of openings, etc.
- G. All valve flange covers shall remain in place until connected piping is in place.
- H. All operating mechanisms shall be operated to check their proper functioning and all nuts and bolts checked for tightness.
- I. Valves and other equipment which do not operate easily, or are otherwise defective, shall be repaired or replaced at no additional cost to the OWNER.
- J. Where installation is covered by a Referenced Standard, installation shall be in accordance with that Standard, except as herein modified, and the CONTRACTOR shall certify such. Also note additional requirements in other parts of this Specification.
- K. Unless otherwise noted, joints for valves and appurtenances shall be made up utilizing the same procedures as specified under the applicable type connecting pipe joint and all valves and other items shall be installed in the proper position as recommended by the MANUFACTURER.

- L. CONTRACTOR shall be responsible for verifying MANUFACTURER'S torquing requirements for all valves.

3.02 INSTALLATION OF MANUAL OPERATIONAL DEVICES

- A. Unless otherwise noted, all operational devices shall be installed with the units of the factory, as shown on the Drawings or as acceptable to the ENGINEER to allow accessibility to operate and maintain the item and to prevent interference with other piping, valves and appurtenances.
- B. For manually operated valves 3-inch in diameter and smaller, valve operators and indicators shall be rotated to display toward normal operation locations.
- C. Floor boxes, valve boxes, extension stems and low floor stands shall be installed vertically centered over the operating nut, with couplings as required and the elevation of the box top shall be adjusted to conform with the elevation of the finished floor surface or grade at the completion of the Contract.
- D. Boxes and stem guides shall be adequately supported during concrete pouring to maintain vertical alignment.

3.03 INSPECTION, TESTING AND CORRECTION OF DEFICIENCIES

- A. See also Division 1. Take care not to over pressure valves or appurtenances during pipe testing.
- B. If any unit proves to be defective, it shall be replaced or repaired to the satisfaction of the ENGINEER.
- C. Functional Test:
 - 1. Prior to plant start-up, all items shall be inspected for proper alignment, quite operation, proper connection and satisfactory performance.
 - 2. All units shall be operated continuously while connected to the attached piping for at least 8 hours, without vibration, jamming, leakage, or overheating and perform the specified function.
- D. The various pipe lines in which the valves and appurtenances are to be installed are specified to be field tested.
- E. During these tests any defective valve or appurtenance shall be adjusted, removed and replaced, or otherwise made acceptable to the ENGINEER.
- F. Various regulating valves, strainers, or other appurtenances shall be tested to demonstrate their conformance with the specified operational capabilities and any deficiencies shall be corrected or the device replaced or otherwise made

acceptable to the ENGINEER.

3.04 IDENTIFICATION OF VALVES

- A. All valves shall be designated by distinguishing numbers and/or letters on required chart(s) and/or diagram(s).
- B. The CONTRACTOR shall install approved brass tags for all designated items with numbers and/or letters on the tags corresponding to those on the chart(s) and/or diagram(s).
- C. Each valve identification tag to be minimum 19 gauge polished brass: 2-inch diameter.
- D. Each tag to designate appropriate service (1/4 inch stamped black-filled letters) and appropriate valve number (1/2 inch stamped black-filled number).
- E. Tags shall be securely fastened to valves with approved stainless steel screws or rivets, or brass jack chain, in a manner to permit easy reading.
- F. CONTRACTOR shall prepare piping flow diagrams (or re-use those on the contract plans) indicating valve numbers, service, normal position, etc., of each valve.
- G. Diagrams shall be mounted on an ornamental iron frame with hinged plexiglass face for wall mounting. Four (4) frames with plexiglass are required.
- H. The requirements for valve identification specified above applies equally to all valves installed under this and under other sections of these specifications.

3.05 CLEANING

All items (including valve interiors) shall be cleaned prior to installation, testing, disinfection and final acceptance.

3.06 DISINFECTION

Disinfection of valves and appurtenances shall be in accordance with AWWA Requirements.

3.07 SETTING VALVES AND BOXES

- A. Valves and valve boxes as specified in the preceding paragraphs shall be installed where shown on the drawings unless otherwise directed.
- B. Valves shall be set plumb with the base of the valve box centered over the valve and resting on compacted backfill.

CITY OF CALLAWAY CHERRY STREET DIRECTIONAL BORE

- C. The top section of the box shall be set to allow equal movement above and below finished grade.
- D. After being correctly positioned, fill shall be carefully tamped around the valve box for a distance of 4-feet on all sides of the box.
- E. In paved areas, top of the cover shall be flush with the finished paving.
- F. In off-street areas, the cover shall be set 1-inch above existing grade unless otherwise directed by the ENGINEER and a concrete pad shall be poured around the top of the box as shown in the standard details.

END OF SECTION

CONSTRUCTION PLANS FOR THE CHERRY STREET DIRECTIONAL BORE

PREPARED FOR:

CITY OF CALLAWAY BAY COUNTY, FLORIDA

PREPARED BY:



203 ABERDEEN PKWY, PANAMA CITY, FL 32405
(850) 522-0644

PROJECT NUMBER - 50093562

APRIL 2018

BID SET
NOT FOR CONSTRUCTION



CITY OFFICIALS:

Mayor Pam Henderson

Ward I Commissioner - Scott Davis

Ward II Commissioner - David Griggs

Ward III Commissioner - Ron Fairbanks

Ward IV Commissioner - Joseph R. Townsend

City Manager - Eddie Cook

Public Works Director - Oscar Martinez

VICINITY MAP

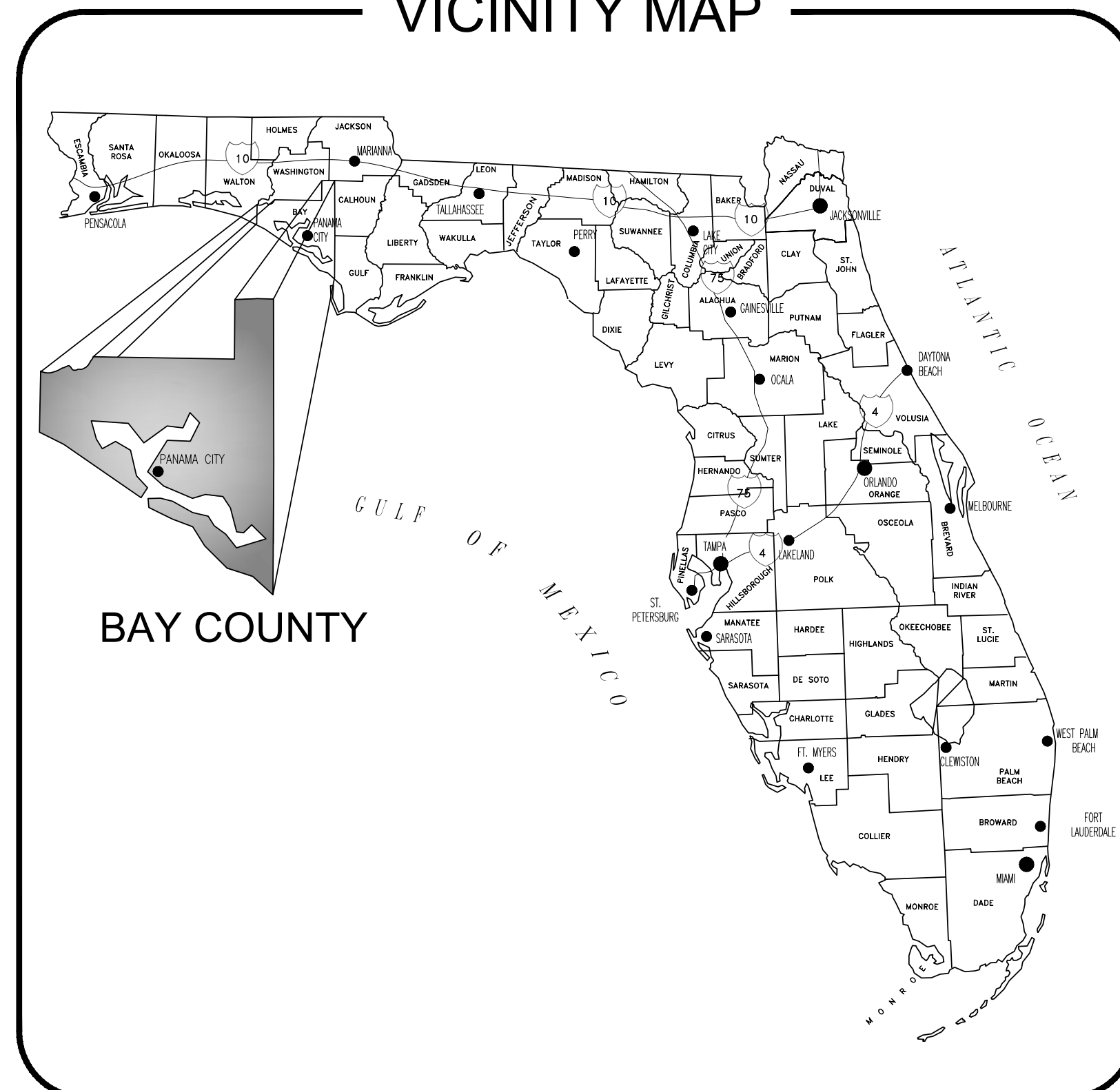

LOCATION MAP

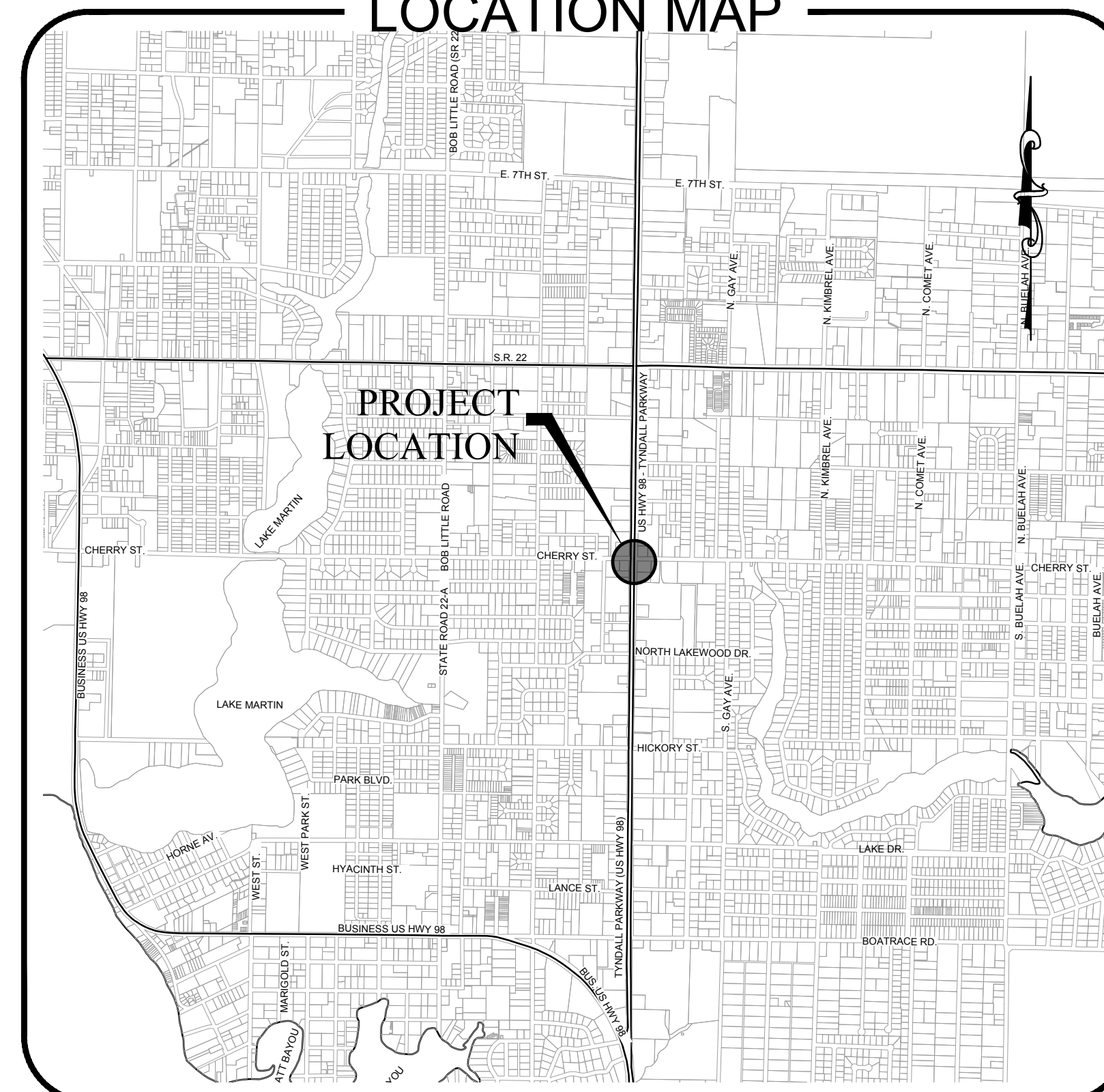

DRAWING INDEX

TITLE	NO.
TOPOGRAPHIC SURVEY	S1
SITE PLAN & PROFILE	C1
DETAILS	D1

April 27, 2018 (08:47:18 EST)
 DRAWING NAME: M:\50093562\CALLAWAY_CHERRY ST. DIRECTIONAL BORE SURVEY.DWG\50093562 CHERRY ST.DWG - S(1) BY: BROCHER

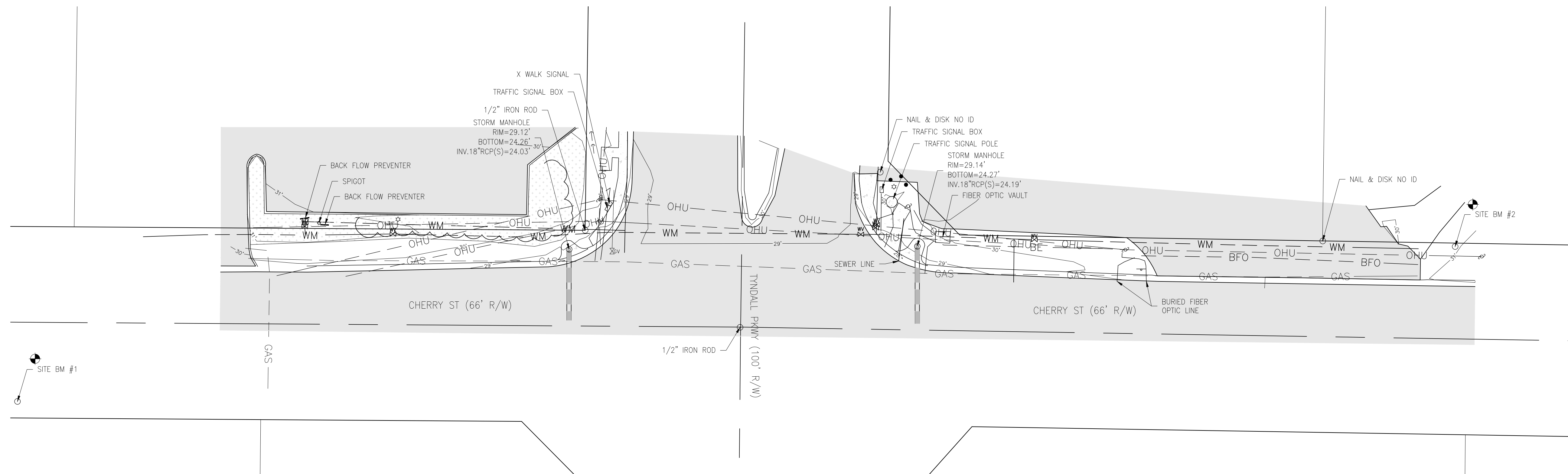

SYMBOLS & ABBREVIATIONS:

- # = NUMBER
- L.B. = LICENSED BUSINESS
- P.S.M. = PROFESSIONAL SURVEYOR AND MAPPER
- INV. = INVERT
- RCP = REINFORCED CONCRETE PIPE
- TS = TRAFFIC SIGN
- WV = WATER VALVE
- SSM = STORM SEWER MANHOLE
- GV = GAS VALVE
- CWB = CONCRETE/WOOD BOLLARD
- GA = GUY ANCHOR
- UP = UTILITY POLE
- SB = SITE BENCHMARK
- 10' = CONTOUR ELEVATION AT 1' INTERVALS
- BFO = BURIED FIBER OPTIC CABLE LINE
- BE = BURIED ELECTRIC LINE
- GAS = BURIED GAS LINE
- SS = BURIED SANITARY SEWER GRAVITY LINE
- WM = BURIED WATER MAIN
- OHU = OVERHEAD UTILITY LINE
- [Hatched Box] = EXISTING ASPHALT PAVEMENT
- [Dotted Box] = EXISTING CONCRETE
- [Stippled Box] = EXISTING LANDSCAPE

SITE BENCHMARKS:

1. SET 5/8" CAPPED IRON ROD L.B. 8011 - ELEVATION = 29.78'
2. SET 5/8" CAPPED IRON ROD L.B. 8011 - ELEVATION = 31.06'

SURVEYOR'S NOTES:

1. SURVEY SHOWN HEREON IS REFERENCED TO FLORIDA STATE PLANE COORDINATES, NORTH ZONE, NAD 1983/90, U.S. SURVEY FEET, ESTABLISHED WITH SPECTRA PRECISION EPOCH 80 GNSS RTK-GPS SYSTEM, TOGETHER WITH THE FLORIDA DEPARTMENT OF TRANSPORTATION PERMANENT REFERENCE NETWORK (FPRN).
2. VERTICAL DATUM SHOWN HEREON IS REFERENCED TO NAVD 1988.
3. THIS SURVEY, MAP, AND REPORT IS NOT VALID WITHOUT THE SIGNATURE AND ORIGINAL RAISED SEAL OF A FLORIDA LICENSED SURVEYOR AND MAPPER. ADDITIONS OR DELETIONS TO SURVEY MAPS OR REPORTS BY OTHER THAN THE SIGNING PARTY OR PARTIES IS PROHIBITED WITHOUT WRITTEN CONSENT OF THE SIGNING PARTY OR PARTIES.
4. NO UNDERGROUND UTILITIES, UTILITY LINES, FOUNDATIONS, OR OTHER UNDERGROUND STRUCTURES HAVE BEEN LOCATED BY DEWBERRY/PREBLE-RISH, EXCEPT AS SHOWN.
5. DATE OF FIELD SURVEY: APRIL 16, 2018.

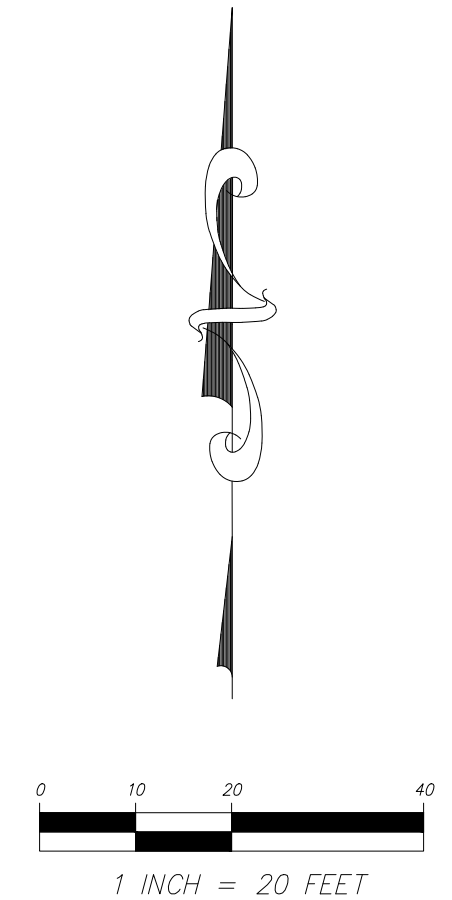

NO.	DATE	REVISION

Dewberry
 DEWBERRY ENGINEERS, INC.
 1000 W. GARDNER STREET
 PANAMA CITY, FLORIDA 32405
 PHONE: 850.522.0644 FAX: 850.522.1011
 WWW.DEWBERRY.COM
 CERTIFICATE OF AUTHORIZATION NO. LB 8011

DAVID JON BARRETT, P.S.M.
 PROFESSIONAL SURVEYOR & MAPPER NO. 139018
 DATE SIGNED

TOPOGRAPHIC SURVEY
 CITY OF CALLAWAY
 BAY COUNTY, FLORIDA

FB/PG
 258/59-60
 FIELD DATE
 4/16/2018
 DRAWING DATE
 4/17/2018
 BY
 AF
 APPROVED
 DJB

PROJECT NO.
 50093562
 SCALE
 1" = 20'

S1

WARNING: GAS MAIN IN AREA OF CONSTRUCTION

- SITE BENCHMARKS:**
- SET 5/8" CAPPED IRON ROD L.B. 8011 - ELEVATION = 29.78'
 - SET 5/8" CAPPED IRON ROD L.B. 8011 - ELEVATION = 31.06'



203 Aberdeen Parkway
Panama City, FL 32405
850.522.0644

CHERRY STREET DIRECTIONAL BORE
CITY OF CALLAWAY
BAY COUNTY
FLORIDA

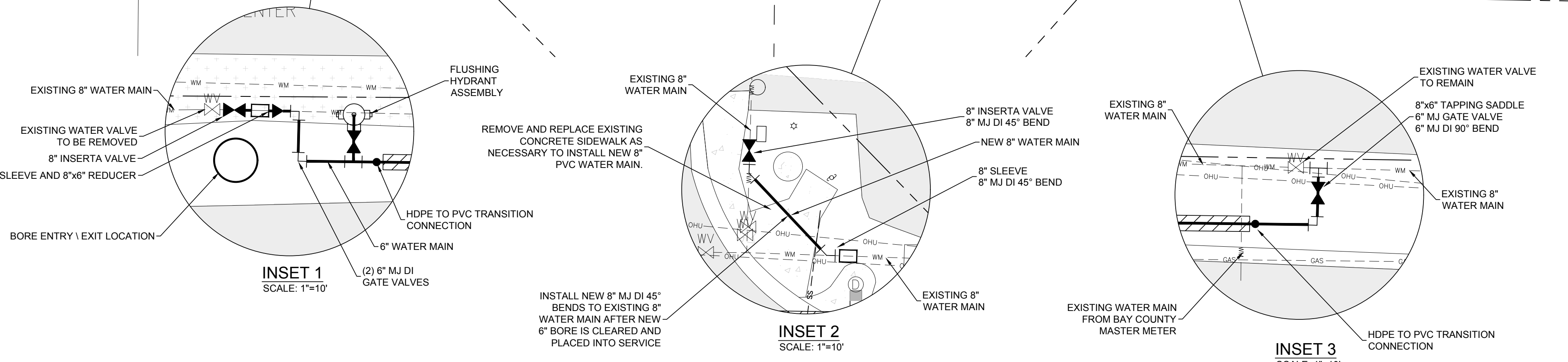
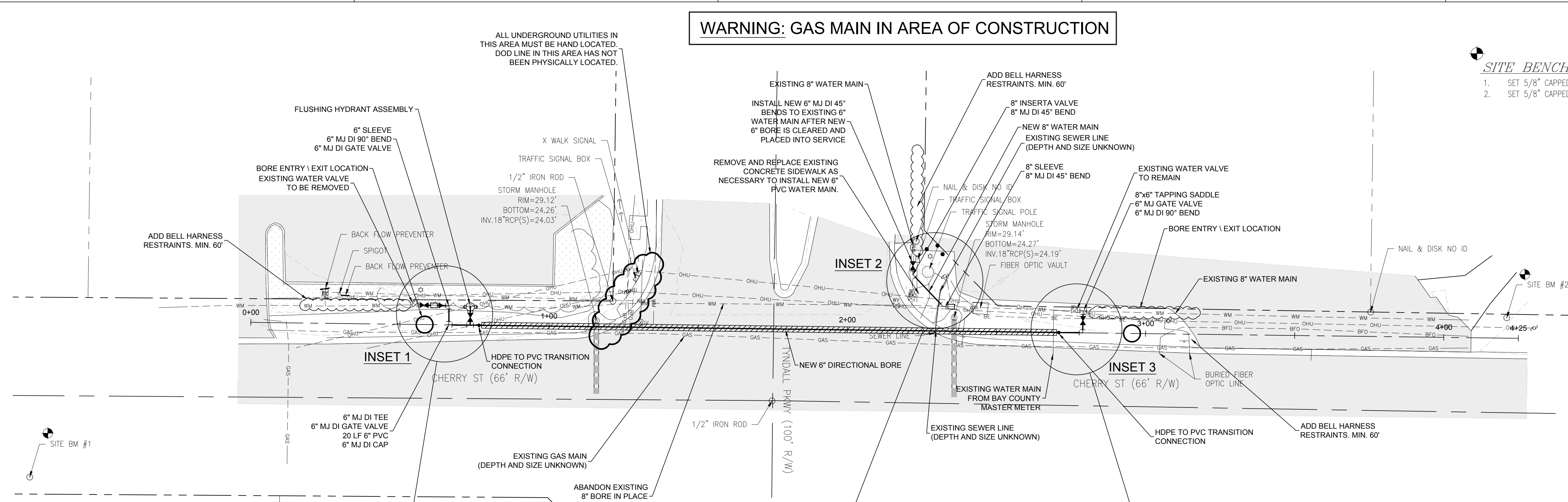

- SYMBOLS & ABBREVIATIONS:**
- # = NUMBER
 - L.B. = LICENSED BUSINESS
 - P.S.M. = PROFESSIONAL SURVEYOR AND MAPPER
 - INV. = INVERT
 - RCP = REINFORCED CONCRETE PIPE
 - TS = TRAFFIC SIGN
 - WV = WATER VALVE
 - SM = STORM SEWER MANHOLE
 - GV = GAS VALVE
 - CB = CONCRETE/WOOD BOLLARD
 - GA = GUY ANCHOR
 - UP = UTILITY POLE
 - SB = SITE BENCHMARK
 - 10' = CONTOUR ELEVATION AT 1' INTERVALS
 - BFO = BURIED FIBER OPTIC CABLE LINE
 - BE = BURIED ELECTRIC LINE
 - GAS = BURIED GAS LINE
 - SS = BURIED SANITARY SEWER GRAVITY LINE
 - WM = BURIED WATER MAIN
 - OHU = OVERHEAD UTILITY LINE
 - [Pattern] = EXISTING ASPHALT PAVEMENT
 - [Pattern] = EXISTING CONCRETE
 - [Pattern] = EXISTING LANDSCAPE

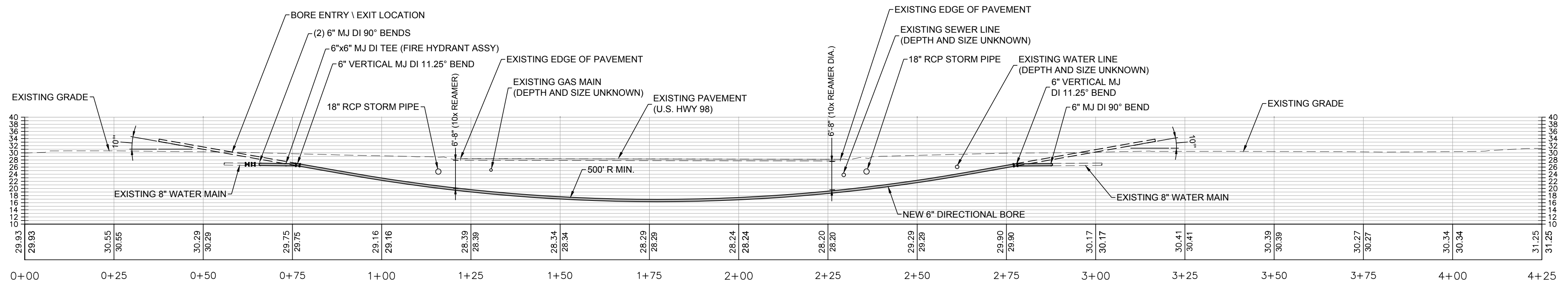

SCALE: 1"=20' HORIZ.
1"=20' VERT.

SEAL

JONATHAN SKLARSKI, P.E. 67361
EB 0008794

BID SET
NOT FOR CONSTRUCTION

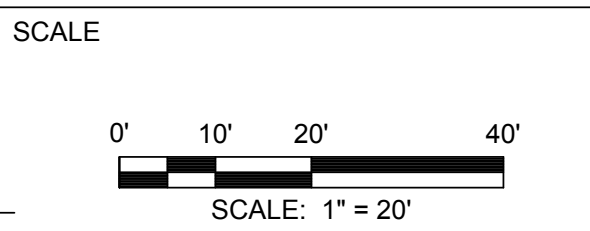

REVISIONS

NO.	DESCRIPTION	DATE

DRAWN BY: BWR
APPROVED BY: JMS
CHECKED BY: EP
DATE: APRIL 2018

TITLE: **PLAN VIEW**

PROJECT NO. 50093562

C-1

SHEET NO.

May 11, 2018 (08:32:50 EST) K:\50093562_CALLAWAY_CHERRY STREET DIRECTIONAL BORE\DWG\REFERENCE\50093562_DSD\DWG C-1 PLAN VIEW BY: BROCHER

REVISIONS

NO.	DESCRIPTION	DATE

DRAWN BY _____ BWR
APPROVED BY _____ JMS
CHECKED BY _____ EHP
DATE _____ NOVEMBER 2017

TITLE
**MISCELLANEOUS
DETAILS**

PROJECT NO. 5008994

D1

SHEET NO.

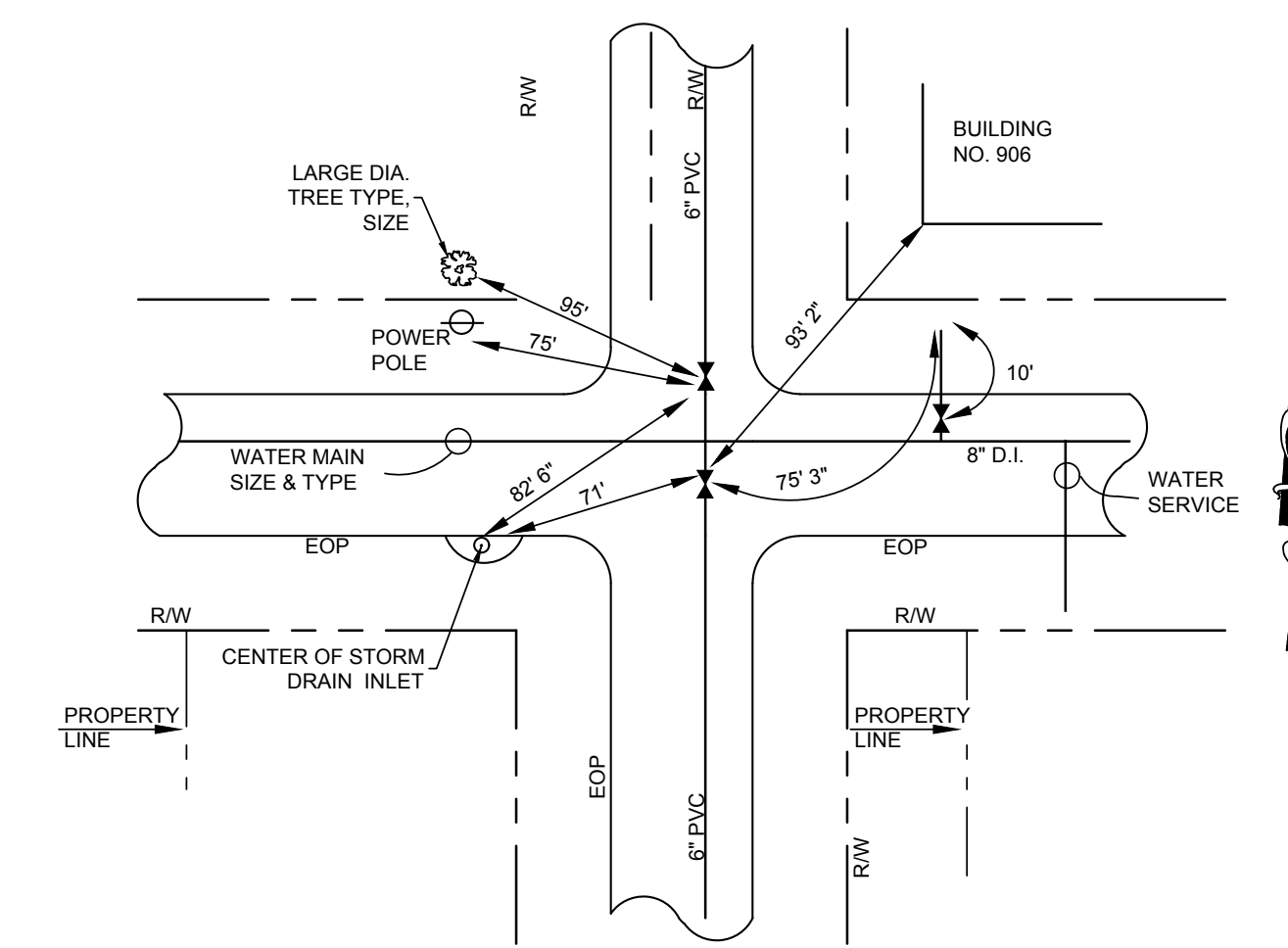

EXAMPLE FOR AS BUILT DRAWINGS OF WATER LINES AND VALVES

NOTES:
1. AS BUILT DRAWINGS WILL BE PREPARED INDICATING LOCATIONS OF ALL SERVICES, LOCATIONS AND TYPES OF ALL FITTINGS, WITH RESPECT TO LOT CORNERS. LOCATIONS OF ALL VALVE AND DEAD END RUNS WITH THREE (3) TIES TO PHYSICAL FEATURES (BUILDING CORNERS, MAN HOLES, EXISTING STRUCTURES, POWER POLES, STORM DRAIN INLETS, CENTER OF FIRE HYDRANTS, FACE OF LARGE DIAMETER TREES >18").
2. AS BUILT DRAWINGS MUST BE SUBMITTED TO THE ENGINEER FOR REVIEW AND APPROVAL BEFORE A LETTER OF ACCEPTANCE WILL BE ISSUED.
3. CONTRACTOR SHALL ALSO PROVIDE CERTIFIED AS-BUILTS BY A P.S.M. REGISTERED IN THE STATE OF FLORIDA IN DIGITAL AND HARD COPY SIGNED AND SEALED. THE AS-BUILTS SHALL BE IN STATE PLANE COORDINATES.

DETAIL AS-BUILT REQUIREMENTS
SCALE: N.T.S.

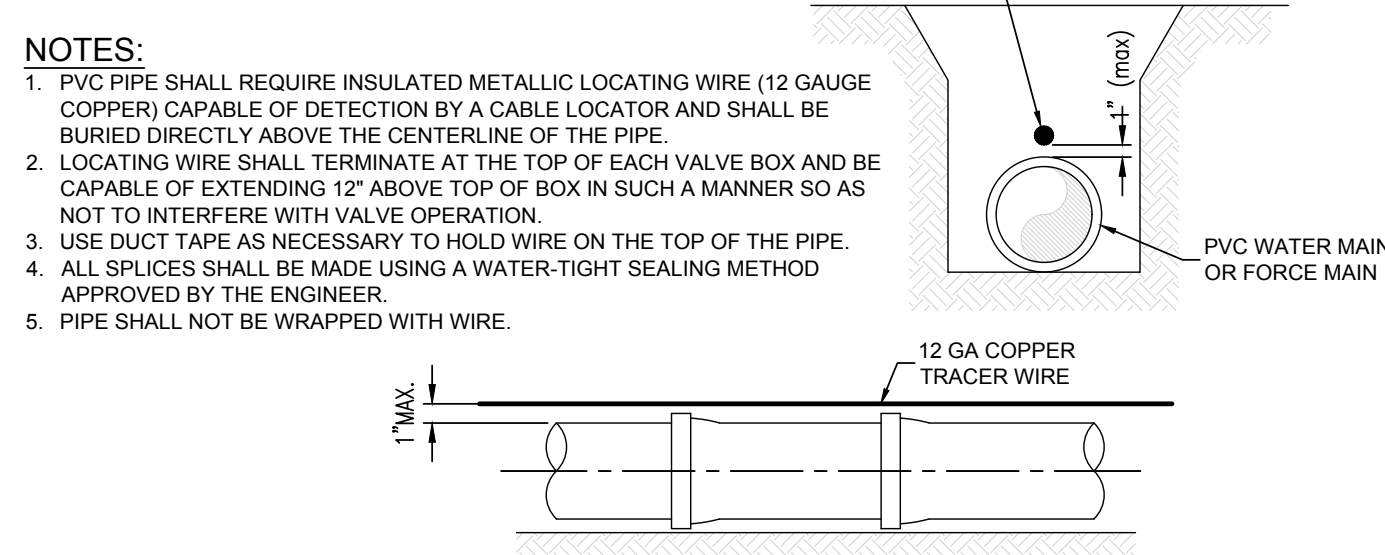

DETAIL PVC PIPE LOCATING WIRE DETAIL
SCALE: N.T.S.

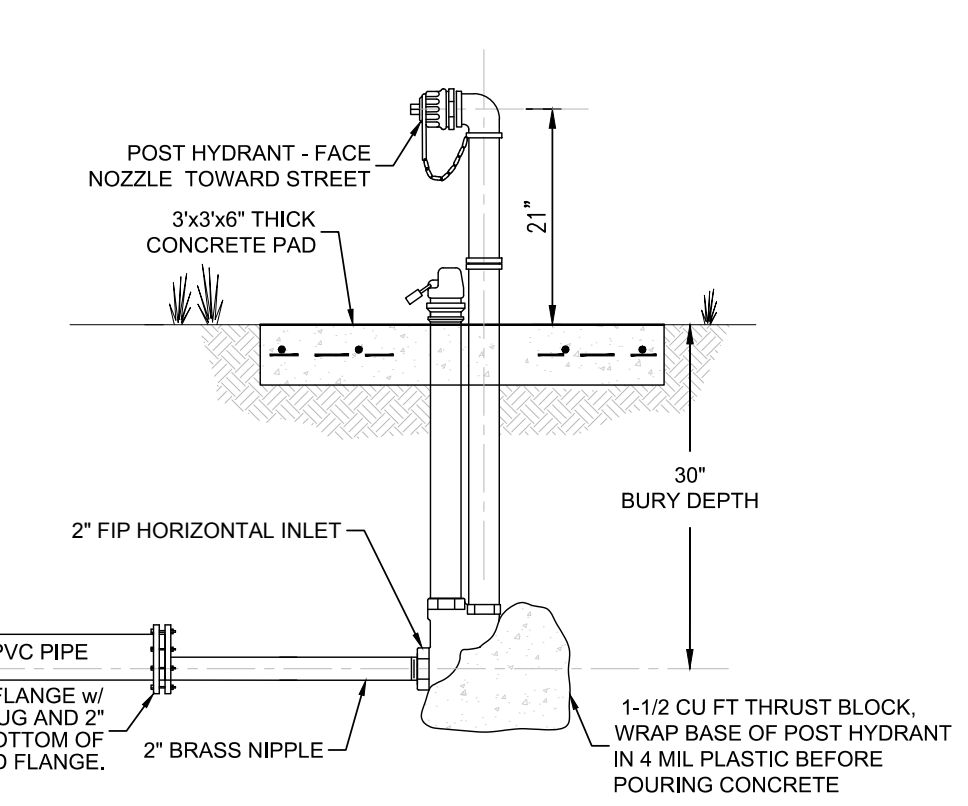

NOTE:
POST HYDRANTS SHALL BE NON-FREEZING, SELF DRAINING TYPE WITH A 30" BURY. HYDRANTS SHALL BE FURNISHED WITH A 2" FIP HORIZONTAL INLET, A NON-TURNING OPERATING ROD, AND SHALL OPEN LEFT. BRONZE OPERATING MECHANISM AND ALUMINUM PLUNGER DESIGN, AND BE SERVICABLE FROM ABOVE GRADE WITH NO DIGGING. THE OUTLET SHALL ALSO BE BRONZE AND BE 2-1/2" NST. HYDRANTS SHALL BE LOCKABLE TO PREVENT UNAUTHORIZED USE. MAINS AUSTRIAN NO. 77 AS MANUFACTURED BY KUPFERLE FOUNDRY CO., ST. LOUIS, MO, OR CITY APPROVED EQUAL.

DETAIL FLUSHING POST HYDRANT ASSEMBLY
SCALE: N.T.S.

MAIN PIPE SIZE	HORIZ. BENDS			TEES								REDUCERS				PLUGS
	90°	45°	22.5°	SIZE		LENGTH		SIZE		LENGTH		SIZE		LENGTH		
48	128	53	26	X48	X42	X36	X30	X24	X42	X36	X30	X24	X42	X36	X30	321
42	117	49	24	X42	X36	X30	X24	X18	X42	X36	X30	X24	X42	X36	X30	289
36	106	44	21	X36	X30	X24	X18	X12	X36	X30	X24	X18	X36	X30	X24	257
30	93	39	19	X30	X24	X18	X12	X6	X30	X24	X18	X12	X30	X24	X18	222
24	79	33	16	X24	X18	X12	X6	X3	X24	X18	X12	X6	X24	X18	X12	185
20	68	29	14	X20	X16	X12	X10	X8	X20	X16	X12	X10	X20	X16	X12	159
16	57	24	12	X16	X12	X10	X8	X6	X16	X12	X10	X8	X16	X12	X10	131
12	45	19	9	X12	X10	X8	X6	X4	X12	X10	X8	X6	X12	X10	X8	102
10	39	16	8	X10	X8	X6	X4	X3	X10	X8	X6	X4	X10	X8	X6	87
8	33	14	7	X8	X6	X4	X3	X2	X8	X6	X4	X3	X8	X6	X4	72
6	25	11	5	X6	X4	X3	X2	X1	X6	X4	X3	X2	X6	X4	X3	55
4	18	8	4	X4	X3	X2	X1	X1	X4	X3	X2	X1	X4	X3	X2	39

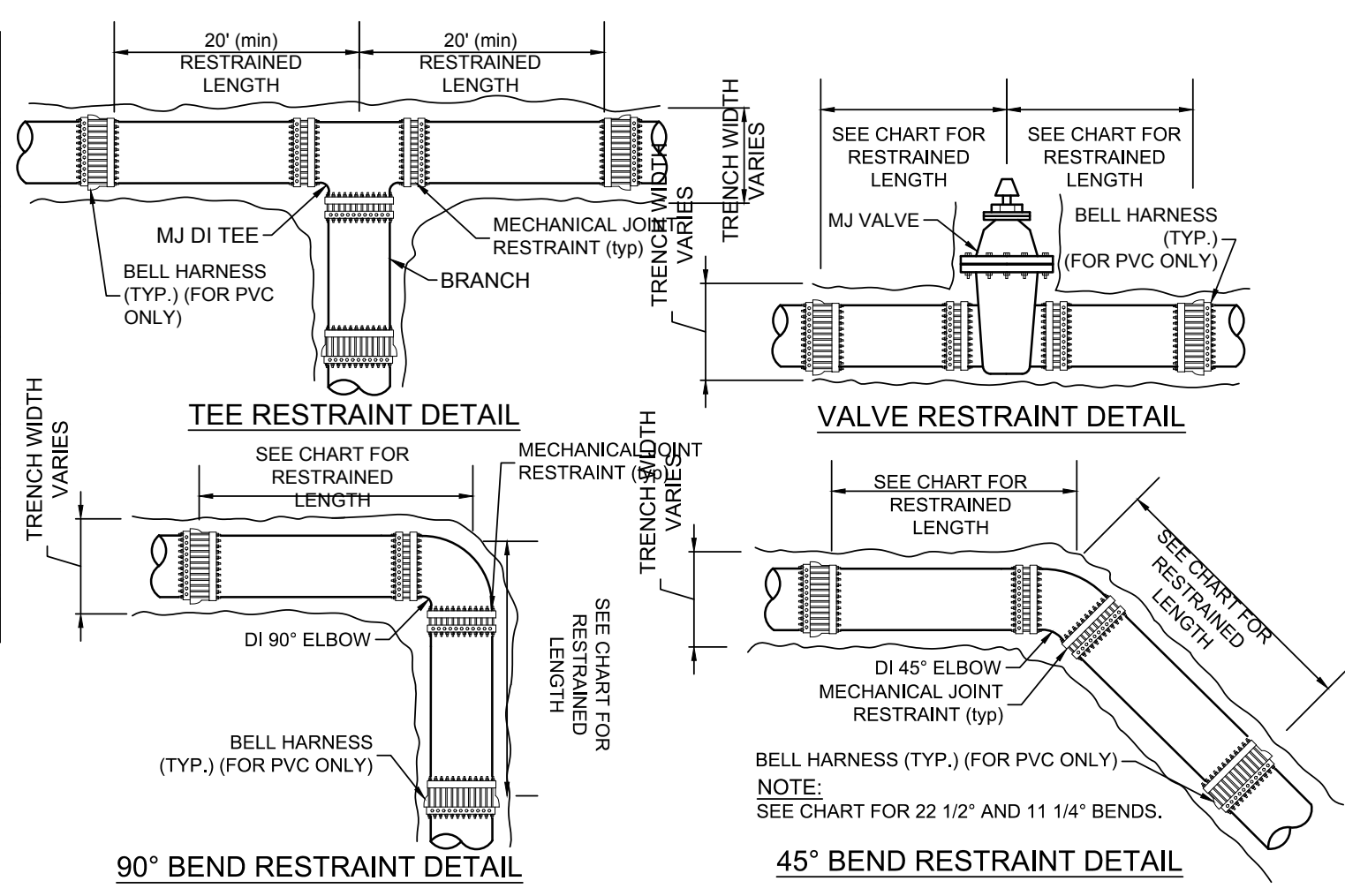

NOTES:
1. RESTRAIN TO NEXT FULL JOINT BEYOND GIVEN LENGTH.
2. RESTRAIN 11.25° BENDS 50% OF LENGTH FOR 22.5° BENDS.
3. ALL VALVES AND FITTINGS SHALL BE RESTRAINED TO THE CONNECTING SECTIONS OF PIPE.
4. ALL VALVES MUST BE PROPERLY ANCHORED OR RESTRAINED TO RESIST A 150 PSI TEST PRESSURE IN EITHER DIRECTION.
5. PIPE SIZES ARE GIVEN IN INCHES.
6. PIPE LENGTHS ARE GIVEN IN FEET.
7. LENGTHS SHOWN ARE FOR A TEST PRESSURE OF 150 PSI.
8. RESTRAIN LENGTHS ARE TO BE USED FOR WATER.
9. THE RESTRAINED LENGTHS SHOWN IN THESE TABLES ARE BASED ON THE USE OF LIGHTLY COMPACTED CLEAN SAND WITH AT LEAST A 95% COARSE PARTICLE CONTENT. ACTUAL SOIL CONDITIONS MUST BE DETERMINED BY THE ENGINEER OF RECORD AND THE RESTRAINED LENGTHS MODIFIED ACCORDINGLY. SAFETY FACTOR OF 1.5:1 TO BE CALCULATED WITH A "SM" SOIL TYPE AND "TRENCH TYPE 3".

DETAIL THRUST RESTRAINTS
SCALE: N.T.S.

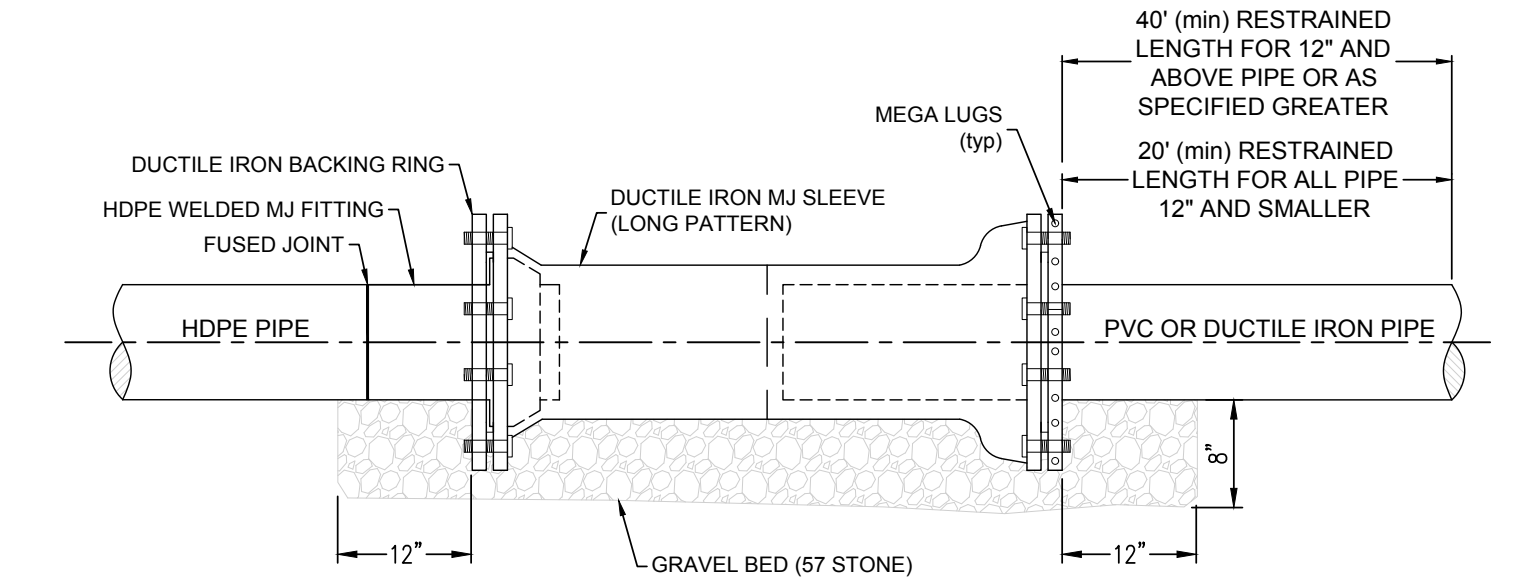

DETAIL HDPE TRANSITION CONNECTION
SCALE: N.T.S.

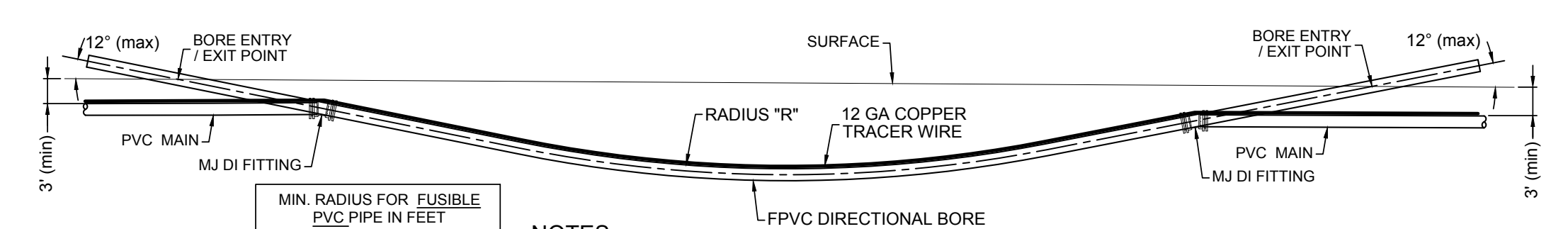

PIPE DIAMETER "D" (in)	MIN. RADIUS "R" FOR DR-18 (ft)
3	73
4	100
6	144
8	189
10	231
12	275
16	363
18	408
20	450

NOTES:
1. ALL POLYETHYLENE PIPING SHALL MEET OWNER STANDARDS AND SPECIFICATIONS.
2. SDR-11, CLASS 160 FOR POTABLE WATER & RECLAIMED WATER SDR-11, CLASS 160 FOR SANITARY FORCE MAINS COLOR CODED BLUE FOR POTABLE WATER COLOR CODED PURPLE FOR RECLAIMED WATER COLOR CODED GREEN FOR SANITARY FORCE MAIN.
3. THE COLOR CODING SHALL MEETING REQUIREMENTS IN ACCORDANCE WITH SUBPARAGRAPH 62-555.320 (2)(1)(B) 3 F.A.C. AND SHALL BE CO-EXTRUDED DURING PIPE MANUFACTURING.
4. ALL BORES SHALL BE A MIN. OF 10 TIMES REAMER DIAMETER BELOW EOP OF ROADWAY AND START AND TERMINATE A MIN. OF 6 FEET FROM EOP.
5. CONTRACTOR SHALL PROVIDE A DETAILED "AS-BUILT" PROFILE OF ALL DIRECTIONAL BORE AND JACK AND BORE LOCATION OF ACTUAL PIPE ELEVATIONS AT 10 FOOT INTERVALS ON AS-BUILT PLAN SHEETS.

DETAIL FUSIBLE PVC DIRECTIONAL BORE
SCALE: N.T.S.

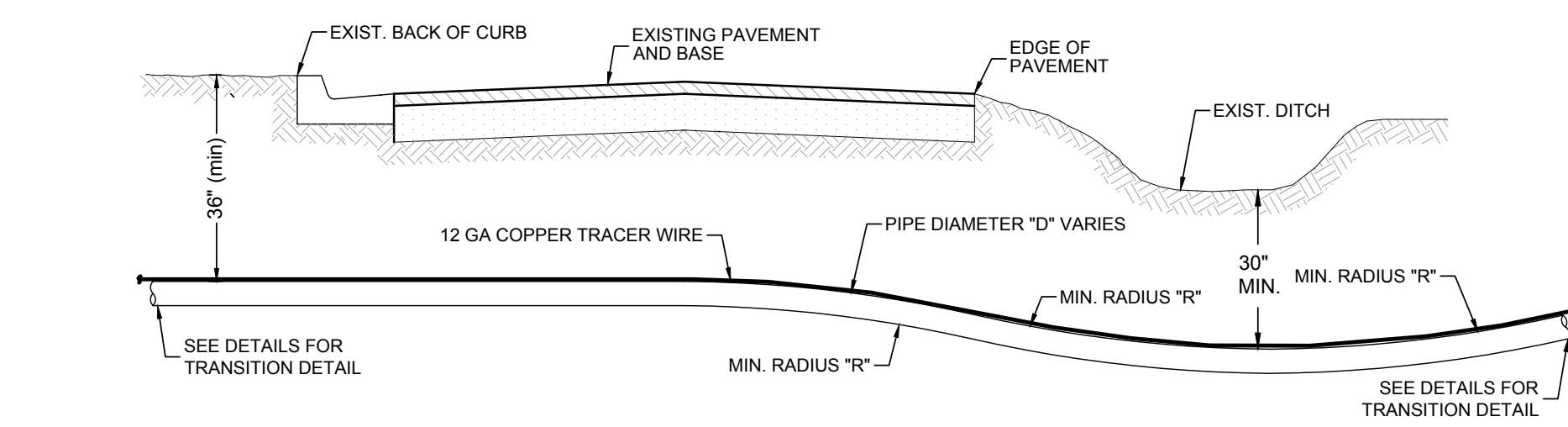

PIPE DIAMETER "D" IN INCHES	MIN. RADIUS FOR HDPE AND FUSIBLE PVC PIPE IN FEET	
	MIN. RADIUS "R" HDPE FOR SDR-11	MIN. RADIUS "R" FUSIBLE PVC FOR DR-18
2	4	XX
3	6	73
4	8	100
6	12	144
8	16	189
10	20	231
12	24	275
16	32	363
18	36	408
20	40	450

DETAIL DIRECTIONAL BORE ROADWAY CROSSING
SCALE: N.T.S.

NOTES:
1. ALL POLYETHYLENE PIPING SHALL MEET CITY STANDARDS AND SPECIFICATIONS.
2. SDR-11, CLASS 160 FOR POTABLE WATER & RECLAIMED WATER SDR-11, CLASS 160 FOR SANITARY FORCE MAINS COLOR CODED BLUE FOR POTABLE WATER COLOR CODED PURPLE FOR RECLAIMED WATER COLOR CODED GREEN FOR SANITARY FORCE MAIN.
3. THE COLOR CODING SHALL MEETING REQUIREMENTS IN ACCORDANCE WITH SUBPARAGRAPH 62-555.320 (2)(1)(B) 3 F.A.C. AND SHALL BE CO-EXTRUDED DURING PIPE MANUFACTURING.
4. ALL HDPE PIPE MUST BE IPS, NO CTS IS ALLOWED.
5. ALL DIRECTIONAL BORES SHALL BE A MINIMUM OF 36 INCHES UNDER ALL ROADWAYS AND START AND TERMINATE A MINIMUM OF 6 FEET OFF THE EDGE OF PAVEMENT.
6. CONTRACTOR SHALL PROVIDE A DETAILED "AS-BUILT" PROFILE OF ALL DIRECTIONAL BORE AND JACK AND BORE LOCATION OF ACTUAL PIPE ELEVATIONS AT 10 FOOT INTERVALS ON AS-BUILT PLAN SHEETS.

April 25, 2018 (16:40:37 EST)
K:\5008994_CALLAWAY_CHERRY STREET DIRECTIONAL BORE_CIVILDRAWING_FOLDER_PRODUCTION\5008994_CALLAWAY_CHERRY STREET DIRECTIONAL BORE_CIVILDWG_BROCHER