

SOLICITATION  
21-61221-001

PUTNAM COUNTY RECREATION  
RESTROOM RENOVATIONS



Putnam County Board of Commissioners  
117 Putnam Drive, Suite A  
Eatonton, GA 31024

AUGUST 27, 2021

3:00 P.M.

# PUTNAM COUNTY BOARD OF COMMISSIONERS



---

117 Putnam Drive, Suite A ♦ Eatonton, GA 31024  
Tel: 706-485-5826 ♦ Fax: 706-923-2345 ♦ [www.putnamcountyga.us](http://www.putnamcountyga.us)

## **PUTNAM COUNTY SOLICITATION # 21-61221-001 Recreation Restroom Renovations**

The Putnam County Board of Commissioners requests sealed bids, good for 60 business days, for a Gymnasium Restroom/Hallway Renovation at the Poole Recreation Center.

**Prospective bidders must obtain a bid package from the Putnam County Board of Commissioners via one of the following methods:**

- on the county website: [www.putnamcountyga.us](http://www.putnamcountyga.us)
- in person at 117 Putnam Drive, Suite A, Eatonton, GA 31024
- by email at [putnamboc@putnamcountyga.us](mailto:putnamboc@putnamcountyga.us)
- by fax at 706-923-2345
- by telephone at 706-485-5826

**Proposals must be submitted on the proposal form issued by Putnam County and contained in the bid package.**

Proposals must be received by **Friday, August 27, 2021 at 3:00 p.m.** The proposals will be read at that time.

LOCAL AND MINORITY OWNED/OPERATED AND/OR WOMEN OWNED/OPERATED BUSINESSES ARE ENCOURAGED TO SUBMIT PROPOSALS.

PUTNAM COUNTY RESERVES THE RIGHT TO REJECT ANY AND ALL BIDS, TO WAIVE ANY AND ALL TECHNICALITIES AND TO AWARD THE BID BASED ON THE LOWEST AND/OR BEST INTEREST OF PUTNAM COUNTY.

08/12/2021; 08/19/2021

# PUTNAM COUNTY BOARD OF COMMISSIONERS



---

117 Putnam Drive, Suite A ♦ Eatonton, GA 31024  
Tel: 706-485-5826 ♦ Fax: 706-923-2345 ♦ [www.putnamcountyga.us](http://www.putnamcountyga.us)

**INSTRUCTIONS AND SPECIFICATIONS FOR BIDDERS:  
SOLICITATION # 21-61221-001  
RECREATION RESTROOM RENOVATIONS  
PUTNAM COUNTY, GEORGIA**

---

## SECTION 1 – GENERAL NOTICE

Sealed proposals for GYMNASIUM RESTROOM/HALLWAY RENOVATIONS AT THE POOLE RECREATION CENTER (SOLICITATION: 21-61221-001) will be received by the office of the Board of Commissioners of Putnam County, Georgia, up to the hour of 3:00 P.M. local time, on Friday, August 27, 2021, at which time and place they will be publicly opened and read aloud. Bidders are invited to be present.

## SECTION 2 – BID DOCUMENTS

Copies of the Proposal, Specifications, Plans (if required) and other document forms may be obtained from the office of the County Commissioners. Bidders are required to examine the same and satisfy themselves that all requirements are fully understood. **It is highly recommended that bidders also personally inspect the location of the project upon which they are bidding.**

## SECTION 3 – BIDDING PROCEDURE

Bids shall be presented in a sealed envelope with the bid number (21-61221-001) and the name of the company or firm submitting clearly marked on the outside of the envelope. **ONE (1) ORIGINAL (PAPER) AND ONE (1) COPY (PAPER) AND A PDF COPY OF THE BID ON A CD OR FLASH DRIVE MUST BE SUBMITTED.** Bids will not be accepted verbally, by fax or email. All appropriate blanks shall be completed. Any interlineations, alteration, or erasure on the specification document shall be initialed by the signer of the bid. Bidder shall not change the proposal form nor make additional stipulations on the specification document. Any amplified or qualifying information shall be on the bidder's letterhead and firmly attached to the bid document. **Items in RED are requirements for bid consideration.**

**Bid prices shall be submitted on the Proposal Form included in the bid document.**

Each bid must be legibly printed in ink or by printer, include the full name, business address, and telephone number of the bidder and be signed in ink by the bidder.

A bid by a firm or organization other than a corporation must include the name and address of each member.

A bid by a corporation must be signed in the name of such corporation by a duly authorized official thereof.

No bidder shall submit more than one proposal nor submit two or more proposals under different names.

**In order to be considered, the outside of the sealed envelope must be clearly marked with the offeror's name, address and phone number, the project number, name of the project for which the proposal is being submitted, and the bid opening date and time of Friday, August 27, 2021 at 3:00 p.m. All proposals shall be delivered by a delivery service or in person to Putnam County Board of Commissioners, 117 Putnam Drive, Suite A, Attn: County Manager, Eatonton, GA 31024, on or before the time and date prescribed above.**

**For your convenience, please use the label on the enclosed "Submittal Requirement" page.**

**Bids received after the time and date established for receiving bids will be rejected.**

#### SECTION 4 – QUALIFICATION OF BIDDERS

**All bidders shall provide a Work Resume and file it with their bid. The resume shall include projects which are similar to the type of work being bid for which the bidder had direct control over and was charged with full responsibility of the outcome.**

#### SECTION 5 – ADDENDA

Addenda are written instruments issued by the County prior to the date for receipt of bids which modify or interpret the specification document by addition, deletion, clarification, or correction.

Addenda will be mailed or delivered to all who are known by the County to have received a complete set of specification documents. Potential bidders may return the "Potential Bidder Form" to ensure they are notified of any addenda issued.

Copies of addenda will be posted on the county website and will also be available for inspection at the office of the County Manager.

No addendum will be issued later than forty-eight (48) hours prior to the date and time for receipt of bids, except an addendum withdrawing the invitation to bid or an addendum which includes postponement of the bid.

**Bidders shall ascertain prior to submitting their bid that they have received all addenda issued and they shall acknowledge receipt of addenda on the proposal form.**

#### SECTION 6 – BIDDER'S REPRESENTATION

Each bidder by signing and submitting a bid, represents that the bidder has read and understands the specification documents and the bid has been made in accordance therewith.

Each bidder for services further represents that the bidder is familiar with the local conditions under which the work is to be done and has correlated the observations with the requirements of the bid documents.

**NON-COLLUSION AFFIDAVIT:** By submitting a proposal, the bidder represents and warrants that such bid is genuine and not a sham or collusion or made in the interest or in behalf of any person not therein named, and that the bidder has not directly or indirectly induced or solicited any other bidder to put in a sham bid, or any other firm, person or corporation to refrain from bidding and that the bidder has not in any manner sought by collusion to secure to that bidder any advantage over any other bidder.

**INTEREST OF:** By submitting a proposal, the bidder represents and warrants that neither a commissioner, administrator, manager, employee, nor any other person employed by PUTNAM COUNTY or in any other way connected with the county has, in any manner, an interest, either directly or indirectly, in the bid or in the contract which may be made under it, or in any expected profits to arise therefrom.

CERTIFICATE OF INDEPENDENT PRICE DETERMINATION: By signing and submitting this bid, the bidder certifies that the prices in this bid have been arrived at independently, without consultation, communication, or agreement, for the purpose of restricting competition, as to any matter relating to such prices with any other bidder or with any competitor; unless otherwise required by law, the prices which have been quoted in this bid have not been knowingly disclosed by the bidder prior to bid opening directly or indirectly to any other bidder or to any competitor; no attempt has been made, or will be made, by the bidder to induce any person or firm to submit, or not to submit, a bid for the purpose of restricting competition.

Various professions within the building industry are required by state law to be licensed. These professions include electricians, plumbers, conditioned air contractors, low voltage contractors, utility contractors, and certain residential and general contractors. Putnam County will be complying with state laws and board rules regarding licensure. **No bid or proposal for projects that require a licensed professional will be accepted from unlicensed persons.** In addition, the licensed contractor must be the prime contractor on the project. It is not permissible for an unlicensed individual/firm to subcontract with a licensed contractor. The validity of all licenses will be checked.

#### SECTION 7 – BIDDER’S SECURITY

BID BOND: not required.

PERFORMANCE BOND: not required.

#### SECTION 8 – EQUAL OPPORTUNITY

Each bidder agrees that it shall not discriminate against any employee or applicant for employment because of race, color, religion, sex, disability, national origin, age, or marital status. In the employment of persons, bidder shall take affirmative action to ensure that applicants are employed and that employees are treated during employment without regard to race, color, religion, sex, disability, national origin, age, or marital status.

#### SECTION 9 – CLARIFICATION OF SPECIFICATION DOCUMENTS

Bidders shall promptly notify the County Manager of any ambiguity, inconsistency, or error which they may discover upon examination of the specification documents.

Bidders desiring clarification or interpretation of the Specification documents shall make a written request which must reach the County Manager at least seven (7) calendar days prior to the date and time for receipt of bids.

Interpretations, corrections, and changes made to the Specification Documents will be made by written addenda. Oral interpretations or changes to the Specification Documents made in any other manner, will not be binding on the County; and bidders shall not rely upon such interpretations or changes.

#### SECTION 10 – SCHEDULE

The project shall be Substantially Complete within 120 calendar days from the date of issuance of Notice to Proceed. Liquidated damaged of \$500 per day will be assessed if work is not completed within 120 calendar days (excluding weather delays) from the date of the Notice to Proceed. Poole Recreation Center is located at 140 Recreation Road SW, Eatonton, GA 31024.

## SECTION 11 – BID EVALUATION AND AWARD

The signed bid proposal shall be considered an offer on the part of the bidder. Such offer shall be deemed accepted upon issuance, by the County, of purchase orders, contract award notifications, or other contract documents appropriate to the work.

No bid shall be modified or withdrawn for a period of sixty (60) calendar days after the time and date established for receiving bids and each bidder so agrees in submitting the bid.

Award will be made to the vendor submitting the lowest responsive and responsible bid. The Putnam County Board of Commissioners reserves the right to reject any or all bids, to waive technicalities and to re-advertise or make an award as deemed in its best interest. The written bid documents supersede any verbal or written prior communication between the parties.

## SECTION 12 – CONTRACT AND BOND

After the acceptance of the bid, the successful bidder must execute a written Contract between the bidder and the County; such contract will incorporate the County's contract documents and be on forms provided by the County.

## SECTION 13 – INSURANCE

**All bidders shall take special note of the attached insurance sheet titled "Insurance Clause for all County Contracts."**

**The successful bidder must provide proof of insurance in accordance with the contract documents.**

## SECTION 14 – INDEMNIFICATION

The bidder shall indemnify and hold harmless the County, its members, its officers, and employees from and against all claims, damages, losses, and expenses, including, but not limited to attorney's fees arising out of or resulting from the performance of the contract, provided that any such claim, damage, loss, or expense is attributable to bodily injury, sickness, disease, or death, or to injury to or destruction of tangible property other than goods, materials, and equipment furnished under this contract, including the loss of use resulting therefrom; is caused in whole or part by any negligent act or omission of the bidder, any subcontractor, or anyone directly or indirectly employed by any one of them or anyone for whose acts made by any of them may be liable, regardless of whether or not it is caused by a party indemnified hereunder.

In any and all claims against the County or its members, officers or employees by an employee of the bidder, any subcontractor, anyone directly or indirectly employed by any of them or by anyone for whose acts made by any of them may be liable, the indemnification obligation listed above shall not be limited in anyway by any limitation of the amount or type of damages, compensation, or benefits payable by or for the bidder or any subcontractor under worker's or workmen's compensation acts, disability benefit acts, or other employee benefit acts.

## SECTION 15 – LAWS

The Laws of the State of Georgia shall govern the rights, obligations, and remedies of the Parties under this proposal and any agreement reached as a result of this process.

## SECTION 16 – INDEPENDENT CONTRACTOR

It is the express intent of the parties that this Contract shall not create an employer-employee relationship, and the Contractor, or any employee or other person acting on behalf of Contractor in the performance of this Contract, shall be deemed to be independent contractor(s) during the entire term of this Contract or any renewals thereof. Contractor shall be responsible for all compensation and benefits payable to Contractor's employee(s) under this Contract and Contractor's employees shall not be entitled to any compensation from County or to any benefits made to their employees, including, but not limited to, overtime, vacation, retirement benefits, workers' compensation, sick leave, or injury leave. Contractor shall also be responsible for maintaining workers' compensation insurance, unemployment insurance, and for payment of all federal, state, local and any other payroll taxes with respect to the employee's compensation.

## SECTION 17 – CERTIFICATION

By signing and submitting a proposal, the bidder certifies that they have carefully examined the plans for this project and the applicable federal, state, and local regulations and the special provisions included in and made a part of this proposal and have also personally examined the site of the work. If awarded, the bidder further proposes to execute the contract agreement described in the specifications as soon as the work is awarded.

## SECTION 18 - DRUG-FREE WORK PLACE CERTIFICATION

By signing and submitting a proposal, the bidder certifies that the provisions of Code Sections 50-24-1 through 50-24-6 of the Official Code of Georgia Annotated, relating to the "Drug-free Work Place Act", have been complied with in full. The bidder further certifies that:

(1) A drug-free work place will be provided for the contractor's employees during the performance of the contract; and

(2) Each contractor who hires a subcontractor to work in a drug-free work place shall secure from that subcontractor a written certification that a drug free work place will be provided for the subcontractor's employees during the performance of this contract pursuant to paragraph (7) of subsection (b) of Code Section 50-24-3.

Also, they further certify that they will not engage in the unlawful manufacture, sale, distribution, dispensation, possession, or use of a controlled substance or marijuana during the performance of the contract.

## SECTION 19 – SECURITY AND IMMIGRATION COMPLIANCE

It is further certified that pursuant to O.C.G.A. §13-10-91 I and all contractors and sub-contractors performing work under this Agreement are in compliance with the Federal Work Authorization Program. Prime contractors and sub-contractors may participate in any of the electronic verification of work authorization programs operated by the United States Department of Homeland Security or any equivalent federal work authorization program operated by the United States Department of Homeland Security to verify information of newly hired employees, pursuant to the Immigration Reform and Control Act of 1986 ("IRCA"). **Contractor Affidavit, Subcontractor Affidavit (if applicable), and Sub-subcontractor Affidavit (if applicable) must be completed and turned in with your bid.**

It is further certified that pursuant to O.C.G.A. §50-36-1 I am a United States citizen, a legal permanent resident of the United States, or a qualified alien or non-immigrant under the Federal Immigration and Nationality Act with an alien number issued by the Department of Homeland Security or other federal immigration agency. **Affidavit must be completed and turned in with your bid, along with a copy of your driver's license.**

## SECTION 20 – PAYMENTS

Contractor shall be paid by and in accordance with Putnam County payment regulations. Putnam County will strive to take advantage of all discounts offered for prompt payment, therefore, indicate all discounts on monthly invoices. Invoices shall not be submitted more frequently than once a month.

## SECTION 21 – SPECIFICATIONS

### Gym Bathroom/Hallway Renovation.

Putnam County is desiring a total renovation of the current restroom facilities, including, new paint, new flooring, new ceiling tiles, new interior and exterior doors, all new fixtures, water fountains, etc. The flooring needs to be durable enough to withstand a lot of traffic.

The hallway is also included in the bathroom project. The two bathroom doors will be replaced along with the door leading into our gymnasium and the door leading to the outside. The entire hallway will need to be painted along with new flooring and base trim. The new water fountain will be added in the hallway. The ceiling frame, tiles and light fixtures will need to be replaced in the bathrooms and hallway.

See attached photos of the existing restroom facilities, existing hallway, existing ceiling tiles, Fixture and Equipment Schedule, and Specs.

For additional information, please contact Recreation Director Scott Haley at 706-485-8565 or onsite at 140 Recreation Road SW, Eatonton, GA 31024.

# PUTNAM COUNTY BOARD OF COMMISSIONERS



---

117 Putnam Drive, Suite A ♦ Eatonton, GA 31024  
Tel: 706-485-5826 ♦ Fax: 706-923-2345 ♦ [www.putnamcountyga.us](http://www.putnamcountyga.us)

**POTENTIAL BIDDER FORM  
SOLICITATION 21-61221-001  
RECREATION RESTROOM RENOVATIONS**

**To: The Putnam County Board of Commissioners**

I have received a copy of the bid documents for the above-mentioned project. Please include me on the list of potential bidders and send me any addendum that may be issued and any other pertinent information.

---

COMPANY NAME

---

STREET ADDRESS or P. O. BOX

---

CITY, STATE, ZIP CODE

---

NAME

---

TITLE

---

EMAIL

---

TELEPHONE #

---

DATE

# IMPORTANT SUBMITTAL REQUIREMENT

Submittals must be properly labeled to ensure they are not inadvertently opened before the designated time. Affix the label below to the outside of the sealed submittal envelope or delivery package.

If this label is not used (i.e. in case of some delivery services), it is the bidder's responsibility to ensure that all required information (offeror's name, address and phone number, the project number, name of the project for which the proposal is being submitted, and the bid opening date and time) is on the OUTSIDE of the delivery package. Submissions that do not comply may be rejected.



FROM:  
Company Name \_\_\_\_\_  
Address: \_\_\_\_\_  
\_\_\_\_\_  
Phone: \_\_\_\_\_

Bid/Proposal #: 21-61221-001  
Bid/Proposal Name: Recreation Restroom Renovations  
Bid Opening Date/Time: Friday, August 27, 2021, 3:00 PM

TO:  
PUTNAM COUNTY BOARD OF COMMISSIONERS  
ATTN: COUNTY MANAGER  
117 PUTNAM DRIVE  
SUITE A  
EATONTON, GA 31024

# PUTNAM COUNTY BOARD OF COMMISSIONERS



117 Putnam Drive, Suite A ♦ Eatonton, GA 31024  
Tel: 706-485-5826 ♦ Fax: 706-923-2345 ♦ [www.putnamcountyga.us](http://www.putnamcountyga.us)

## PROPOSAL FORM SOLICITATION 21-61221-001 RECREATION RESTROOM RENOVATIONS

**To: The Putnam County Board of Commissioners**

Pursuant to the invitation to bid and the instructions to Bidders and according to the specifications attached, the below stated bidder proposes the following prices for Recreation Restroom Renovations at Poole Recreation Center:

\_\_\_\_\_ **does hereby propose the following:**  
**(Name of Bidder)**

\$ \_\_\_\_\_ **(Base Bid)**

**OPTIONS:**

- a) \_\_\_\_\_ \$ \_\_\_\_\_  
b) \_\_\_\_\_ \$ \_\_\_\_\_  
c) \_\_\_\_\_ \$ \_\_\_\_\_

**Grand Total: \$** \_\_\_\_\_

**Additional sheet may be attached for detailed breakdown.**

**MARK OUTSIDE OF BID ENVELOPE AS FOLLOWS:**

**The offeror's name, address, telephone number, the Solicitation # and name, the date Friday, August 27, 2021 at 3:00 p.m. and addressed as follows:**

**Recreation Restroom Renovations  
Attn: Paul Van Haute, County Manager**

I hereby acknowledge receipt of the following checked amendments of the Proposal, Plans and/or Specifications, etc.:

Amendment No's: 1\_\_\_\_, 2\_\_\_\_, 3\_\_\_\_, 4\_\_\_\_, 5\_\_\_\_, I understand that failure to confirm the receipt of amendments is cause for rejection of bids.

Signatures on the following page

The undersigned signatory for the bidder represents and warrants that he has full and complete authority to submit this proposal to the County and to enter into contract with Putnam County.

\_\_\_\_\_  
COMPANY NAME

\_\_\_\_\_  
BY (SIGNATURE)

\_\_\_\_\_  
STREET ADDRESS or P. O. BOX

\_\_\_\_\_  
(PRINT NAME)

\_\_\_\_\_  
CITY, STATE

\_\_\_\_\_  
ZIP CODE

\_\_\_\_\_  
(TITLE)

\_\_\_\_\_  
TELEPHONE NO.

\_\_\_\_\_  
FAX NO.

\_\_\_\_\_  
(DATE)

\_\_\_\_\_  
EMPLOYERS FEDERAL I.D. NO or  
SOCIAL SECURITY NUMBER

\_\_\_\_\_  
Email

The Bidder(s) whose signature(s) appears on this document, having personally appeared before me, and being duly sworn, deposes and says that the above statements are true and correct.

Sworn to and subscribed before me this \_\_\_\_\_ day of \_\_\_\_\_, 20\_\_\_\_\_.

Notary signature: \_\_\_\_\_

My commission expires: \_\_\_\_\_ (seal)

# PUTNAM COUNTY BOARD OF COMMISSIONERS



117 Putnam Drive, Suite A ♦ Eatonton, GA 31024  
Tel: 706-485-5826 ♦ Fax: 706-923-2345 ♦ [www.putnamcountyga.us](http://www.putnamcountyga.us)

## INSURANCE CLAUSE FOR ALL COUNTY CONTRACTS

The Contractor shall indemnify and hold harmless, to the fullest extent allowed by law, Putnam County, Georgia, its members, its officers and employees from and against all losses, claims, damages and expenses, including court-ordered attorney's fees, arising out of or resulting from the performance of the contract that results in bodily injury, sickness, disease, death or injury to or destruction of tangible property, including the loss of use resulting therefrom and is caused in whole or in part by the Contractor, any subcontractor, anyone directly or indirectly employed by any of them or anyone for whose acts any of them may be liable.

Contractor shall not commence work under this contract until he has obtained all insurance required under this Section and such insurance has been approved by PUTNAM COUNTY, nor shall the Contractor allow any subcontractor to commence work on his subcontract until all similar insurance required of the subcontractor has been so obtained and approved.

A. Workers' Compensation Insurance and Employer's Liability Insurance:

The Contractor shall take out and maintain during the life of this contract the applicable statutory Worker's Compensation Insurance, and in the case of any work sublet, the Contractor shall require the subcontractor similarly to provide statutory Worker's Compensation Insurance for the latter's employees. Coverage shall be provided by an insurance company authorized to write such insurance in all states where the Contractor will have employees located in the performance of this contract, and the Contractor shall require each of his subcontractors similarly to maintain Employer's Liability Insurance similarly to the Contractor.

Worker's Compensation – Required limits:

Coverage A – Coverage will include Statutory requirements

Coverage B – Employers Liability

\$100,000 Each Person

\$100,000 Each Person by Disease

\$500,000 Policy Limit – Disease

B. General Liability Insurance

1. The Contractor shall maintain during the life of this contract, Commercial General Liability Insurance, naming and protecting him and Putnam County against claims for damages resulting from (a) bodily injury, including wrongful death, and (b) property damage which may arise from operations under this contract whether such operations be by himself or by any subcontractor or anyone directly or indirectly employed by either of them. The insurance requirements are:

Commercial General Liability with limits of:  
\$1,000,000 Each Occurrence  
\$1,000,000 Personal Injury  
\$2,000,000 Products/Completed Operations  
\$2,000,000 General Aggregate

2. Coverage shall include Contractual Liability coverage insuring the contractual exposure as addressed in this contract.
  3. There shall be no exclusion or limitation for the Explosion (X), Collapse (C) and Underground (U) hazards.
  4. **Putnam County shall be named as Additional Insured.**
  5. The Commercial General Liability coverage shall be endorsed with the Designated Construction Project(s) General Aggregate Limit endorsement.
- C. Automobile Liability Insurance: The Contractor shall take out and maintain during the life of the contract such Automobile Liability Insurance as shall protect him against claims for damages resulting from (a) bodily injury, including wrongful death, and (b) property damage which may arise from the operations of any owned, hired, or non-owned automobiles used by or for him in any capacity in connection with the carrying out of this contract. The minimum acceptable limits of liability to be provided by such Automobile Liability Insurance shall be as follows:

Bodily Injury and Property Damage \$1,000,000 Combined Single Limit

- D. Builder's Risk Insurance: ***(For Building Construction Contracts Only)*** Unless otherwise specified where buildings are to be constructed under this contract, the Contractor shall provide coverage for all direct physical loss (also known as "Special Causes of Loss"). Such insurance shall be written on a Replacement Cost basis covering such building in the amount equal to one-hundred percent (100%) of the contract amount (minimum) as specified herein. Losses, if any, shall be made payable to PUTNAM COUNTY and Contractor as their interest may appear. A certificate of insurance evidencing such insurance coverage shall be filed with PUTNAM COUNTY by the time work on the building begins and such insurance shall be subjected to the approval of PUTNAM COUNTY.
- E. Minimum Scope of Insurance: All Liability Insurance policies shall be written on an "Occurrence" basis only. All insurance coverage is to be placed with insurers authorized to do business in the State of Georgia.
- F. Certificate of Insurance: All Certificates of Insurance shall be filed with PUTNAM COUNTY on the standard ACCORD CERTIFICATE OF INSURANCE form showing the specific limits of insurance, coverage modifications and endorsements required by the preceding Sections A, B, C, D and showing PUTNAM COUNTY as an additional insured where required. Such certificate shall specifically state that insurance policies are to be endorsed to require the insurer to provide PUTNAM COUNTY thirty days notice of cancellation, non-renewal or any material reduction of insurance coverage.

***The original certificate shall be provided to the Putnam County Board of Commissioners as designated and mailed to: 117 Putnam Drive, Suite A, Eatonton, GA 31024.***

# PUTNAM COUNTY BOARD OF COMMISSIONERS



117 Putnam Drive, Suite A ♦ Eatonton, GA 31024  
706-485-5826 ♦ 706-923-2345 fax  
[www.putnamcountyga.us](http://www.putnamcountyga.us)

## SAVE Affidavit

**(U.S. Citizens are only required to provide this affidavit one time)**

By executing this affidavit under oath, as bidder to Putnam County Georgia as referenced in O.C.G.A. § 50-36-1, the undersigned applicant verifies one of the following with respect to my application for a public benefit:

**Please check one box only**

- 1)  I am a United States citizen
- 2)  I am a legal permanent resident of the United States
- 3)  I am a qualified alien or non-immigrant under the Federal Immigration and Nationality Act with an alien number issued by the Department of Homeland Security or other federal immigration agency

My alien number issued by the Department of Homeland Security or other federal immigration agency is:

\_\_\_\_\_

The undersigned applicant also hereby verifies that he or she is 18 years of age or older and has provided at least one secure and verifiable document, as required by O.C.G.A. § 50-36-1(e)(1), with this affidavit.

The secure and verifiable document provided with this affidavit can best be classified as:

\_\_\_\_\_.

In making the above representation under oath, I understand that any person who knowingly and willfully makes a false, fictitious, or fraudulent statement or representation in an affidavit shall be guilty of a violation of O.C.G.A. § 16-10-20, and face criminal penalties as allowed by such criminal statute.

Executed in \_\_\_\_\_ (city), \_\_\_\_\_ (state).

Signature of Applicant: \_\_\_\_\_

Printed Name: \_\_\_\_\_

Date \_\_\_\_\_

SUBSCRIBED AND SWORN BEFORE ME ON THIS THE  
\_\_\_\_\_ DAY OF \_\_\_\_\_, 20\_\_\_\_\_

Notary Public Signature: \_\_\_\_\_

Affix Notary stamp/seal here

My Commission Expires: \_\_\_\_\_

# PUTNAM COUNTY BOARD OF COMMISSIONERS



117 Putnam Drive, Suite A ♦ Eatonton, GA 31024  
706-485-5826 ♦ 706-923-2345 fax ♦ www.putnamcountyga.us

## Contractor Affidavit Under O.C.G.A. § 13-10-91(b)(1)

By executing this affidavit, the undersigned contractor verifies its compliance with O.C.G.A. § 13-10-91, stating affirmatively that the individual, firm or corporation which is engaged in the physical performance of services on behalf of the Putnam County Board of Commissioners has registered with, is authorized to use and uses the federal work authorization program commonly known as E-Verify, or any subsequent replacement program, in accordance with the applicable provisions and deadlines established in O.C.G.A. § 13-10-91. Furthermore, the undersigned contractor will continue to use the federal work authorization program throughout the contract period and the undersigned contractor will contract for physical performance of services in satisfaction of such contract only with subcontractors who present an affidavit to the contractor with the information required by O.C.G.A. § 13-10-91(b). Contractor hereby attests that its federal work authorization user identification number and date of authorization are as follows:

\_\_\_\_\_

Federal Work Authorization User Identification Number

\_\_\_\_\_

Date of Authorization

\_\_\_\_\_

Name of Contractor

\_\_\_\_\_

Name of Project

Putnam County Board of Commissioners

Name of Public Employer

I hereby declare under penalty of perjury that the foregoing is true and correct.

Executed on the \_\_\_\_\_ day of \_\_\_\_\_, 20\_\_\_\_ in

\_\_\_\_\_ (city), \_\_\_\_\_ (state).

\_\_\_\_\_

Signature of Authorized Officer or Agent

\_\_\_\_\_

Printed Name and Title of Authorized Officer or Agent

SUBSCRIBED AND SWORN BEFORE ME ON THIS THE

\_\_\_\_\_ DAY OF \_\_\_\_\_, 20\_\_\_\_\_

\_\_\_\_\_

Notary Public Signature

My Commission Expires:

# PUTNAM COUNTY BOARD OF COMMISSIONERS



117 Putnam Drive, Suite A ♦ Eatonton, GA 31024  
706-485-5826 ♦ 706-923-2345 fax ♦ www.putnamcountyga.us

## Subcontractor Affidavit Under O.C.G.A. § 13-10-91(b)(3)

By executing this affidavit, the undersigned subcontractor verifies its compliance with O.C.G.A. § 13-10-91, stating affirmatively that the individual, firm or corporation which is engaged in the physical performance of services under a contract with \_\_\_\_\_ (name of contractor) on behalf of the Putnam County Board of Commissioners has registered with, is authorized to use and uses the federal work authorization program commonly known as E-Verify, or any subsequent replacement program, in accordance with the applicable provisions and deadlines established in O.C.G.A. § 13-10-91. Furthermore, the undersigned subcontractor will continue to use the federal work authorization program throughout the contract period and the undersigned subcontractor will contract for physical performance of services in satisfaction of such contract only with sub-subcontractors who present an affidavit to the subcontractor with the information required by O.C.G.A. § 13-10-91(b). Additionally, the undersigned subcontractor will forward notice of the receipt of an affidavit from a sub-subcontractor to the contractor within five business days of receipt. If the undersigned subcontractor receives notice of receipt of an affidavit from any sub-subcontractor that has contracted with a sub-subcontractor to forward, within five business days of receipt, a copy of such notice to the contractor. Subcontractor hereby attests that its federal work authorization user identification number and date of authorization are as follows:

\_\_\_\_\_  
Federal Work Authorization User Identification Number

\_\_\_\_\_  
Date of Authorization

\_\_\_\_\_  
Name of Subcontractor

\_\_\_\_\_  
Name of Project

Putnam County Board of Commissioners

Name of Public Employer

I hereby declare under penalty of perjury that the foregoing is true and correct.

Executed on the \_\_\_\_\_ day of \_\_\_\_\_, 20\_\_\_\_ in

\_\_\_\_\_ (city), \_\_\_\_\_ (state).

\_\_\_\_\_  
Signature of Authorized Officer or Agent

\_\_\_\_\_  
Printed Name and Title of Authorized Officer or Agent

SUBSCRIBED AND SWORN BEFORE ME ON THIS THE

\_\_\_\_\_ DAY OF \_\_\_\_\_, 20\_\_\_\_\_

\_\_\_\_\_  
Notary Public Signature

My Commission Expires:

# PUTNAM COUNTY BOARD OF COMMISSIONERS



117 Putnam Drive, Suite A ♦ Eatonton, GA 31024  
706-485-5826 ♦ 706-923-2345 fax ♦ www.putnamcountyga.us

## Sub-subcontractor Affidavit Under O.C.G.A. § 13-10-91(b)(4)

By executing this affidavit, the undersigned sub-subcontractor verifies its compliance with O.C.G.A. § 13-10-91, stating affirmatively that the individual, firm or corporation which is engaged in the physical performance of services under a contract with \_\_\_\_\_ (name of subcontractor or sub-subcontractor with whom such sub-subcontractor has privity of contract) and \_\_\_\_\_ (name of contractor) on behalf of the Putnam County Board of Commissioners has registered with, is authorized to use and uses the federal work authorization program commonly known as E-Verify, or any subsequent replacement program, in accordance with the applicable provisions and deadlines established in O.C.G.A. § 13-10-91. Furthermore, the undersigned sub-subcontractor will continue to use the federal work authorization program throughout the contract period and the undersigned sub-subcontractor will contract for the physical performance of services in satisfaction of such contract only with sub-subcontractors who present an affidavit to the sub-subcontractor with the information required by O.C.G.A. § 13-10-91(b). The undersigned sub-subcontractor shall submit, at the time of such contract, this affidavit to \_\_\_\_\_ (name of subcontractor or sub-subcontractor with whom such sub-subcontractor has privity of contract). Additionally, the undersigned sub-subcontractor will forward notice of the receipt of an affidavit from a sub-subcontractor to \_\_\_\_\_ (name of subcontractor or sub-subcontractor with whom such sub-subcontractor has privity of contract). Sub-subcontractor hereby attests that its federal work authorization user identification number and date of authorization are as follows:

\_\_\_\_\_  
Federal Work Authorization User Identification Number

\_\_\_\_\_  
Date of Authorization

\_\_\_\_\_  
Name of Sub-subcontractor

\_\_\_\_\_  
Name of Project

\_\_\_\_\_  
Putnam County Board of Commissioners

\_\_\_\_\_  
Name of Public Employer

I hereby declare under penalty of perjury that the foregoing is true and correct.

Executed on the \_\_\_\_\_ day of \_\_\_\_\_, 20\_\_\_\_ in

\_\_\_\_\_ (city), \_\_\_\_\_ (state).

\_\_\_\_\_  
Signature of Authorized Officer or Agent

\_\_\_\_\_  
Printed Name and Title of Authorized Officer or Agent

SUBSCRIBED AND SWORN BEFORE ME ON THIS THE  
\_\_\_\_\_ DAY OF \_\_\_\_\_, 20\_\_\_\_\_

\_\_\_\_\_  
Notary Public Signature

\_\_\_\_\_  
My Commission Expires:

**FIXTURE AND EQUIPMENT SCHEDULE**

#	FIXTURE TYPE	MODEL NUMBER	FLOW
WC1	STAINLESS STEEL FLOOR MOUNTED FLUSH VALVE WATER CLOSET	WILLOUGHBY INDUSTRIES ETF-1490-OW-TS-1.28 GPF-TW4-HS WATER CLOSET. AMERICAN STANDARD 6147121.002 FLUSH VALVE. BEMIS 1655SSCT SEAT.	1.28 GPF
WC2	ADA STAINLESS STEEL FLOOR MOUNTED FLUSH VALVE WATER CLOSET	WILLOUGHBY INDUSTRIES ETF-1490-OW-TS-HC-1.28 GPF-TW4-HS WATER CLOSET. AMERICAN STANDARD 6147121.002 FLUSH VALVE. BEMIS 1655SSCT SEAT.	1.28 GPF
UR1	STAINLESS STEEL WALL-HUNG URINAL	WILLOUGHBY INDUSTRIES UW-1317-HEU-FA-TS-0.125 GPF URINAL. AMERICAN STANDARD 6145013.002 FLUSH VALVE.	0.125 GPF
UR2	ADA STAINLESS STEEL WALL-HUNG URINAL	WILLOUGHBY INDUSTRIES UW-1317-HEU-FA-TS-0.125 GPF URINAL. AMERICAN STANDARD 6145013.002 FLUSH VALVE.	0.125 GPF
LAV	ADA STAINLESS STEEL WALL-HUNG LAVATORY WITH METERING FAUCET	WILLOUGHBY INDUSTRIES ES-1015-HC-NV-4CC LAVATORY & AMERICAN STANDARD 1340.227 FAUCET.	0.5 GPM
EWC	ADA VANDAL-RESISTANT ELECTRIC WATER COOLER	ELKAY VRCGRNTL8WSK.	

ALL HOLLOW METAL DOORS AND FRAMES SHALL BE 16 GA. EQUAL TO STEELCRAFT. ALL WOOD DOORS SHALL BE PLAIN SLICED RED OAK, 7 PLY CONSTRUCTION WITH FACTORY FINISH EQUAL TO MARSHFIELD

**TOILET ACCESSORY SCHEDULE**

PROVIDE SUBMITTALS WITH CUT SHEETS TO THE OWNER FOR APPROVAL

EACH TOILET SHALL HAVE TWO (2) STAINLESS STEEL SURFACE MOUNTED PAPER TOWEL DISPENSERS AMERICAN SPECIALTIES MDL. NO.0210

EACH TOILET AT EACH SINK LOCATION SHALL BE ONE (1) SURFACE MOUNTED STAINLESS STEEL LIQUID SOAP DISPENSER AMERICAN SPECIALTIES MDL. NO. 0343

AT EACH TOILET IN EACH TOILET STALL SHALL BE ONE (1) SURFACE MOUNTED DOUBLE ROLL TOILET TISSUE HOLDER AMERICAN SPECIALTIES MDL. NO. 0715

AT WOMEN'S TOILETS IN EACH TOILET STALL SHALL BE ONE SURFACE MOUNTED SANITARY NAPKIN DISPOSAL AMERICAN SPECIALTIES MDL. NO. 0852

AT EACH TOILET IN EACH HANDICAPPED TOILET STALL SHALL BE TWO (2) 1 1/2" DIA. GRAB BARS AMERICAN SPECIALTIES SERIES NO. 3800

ABOVE EACH SINK LOCATION IN EACH TOILET PROVIDE ONE (1) 18" WIDE X 50" HIGH ALLUM. FRAMED MIRROR AMERICAN SPECIALTIES NO. 0620

AT EACH MEN'S AND WOMEN'S TOILET PROVIDE ONE (1) FREE STANDING WASTE RECEPTACLE AMERICAN STANDARD NO. 0813

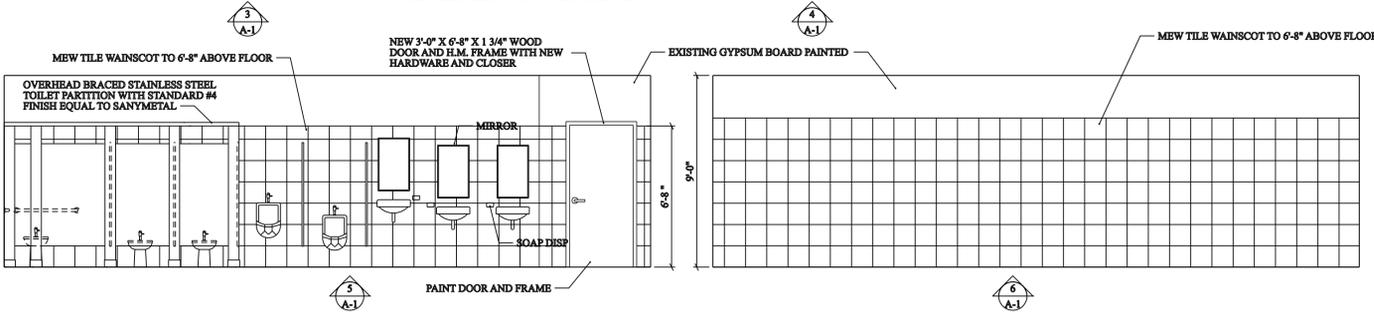
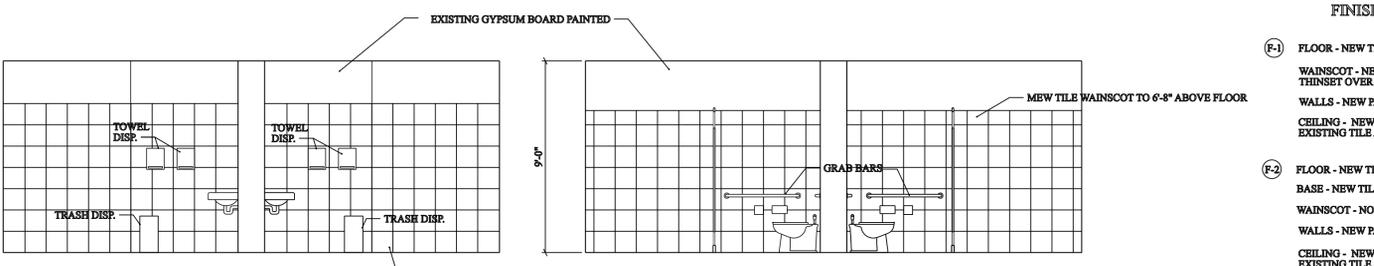
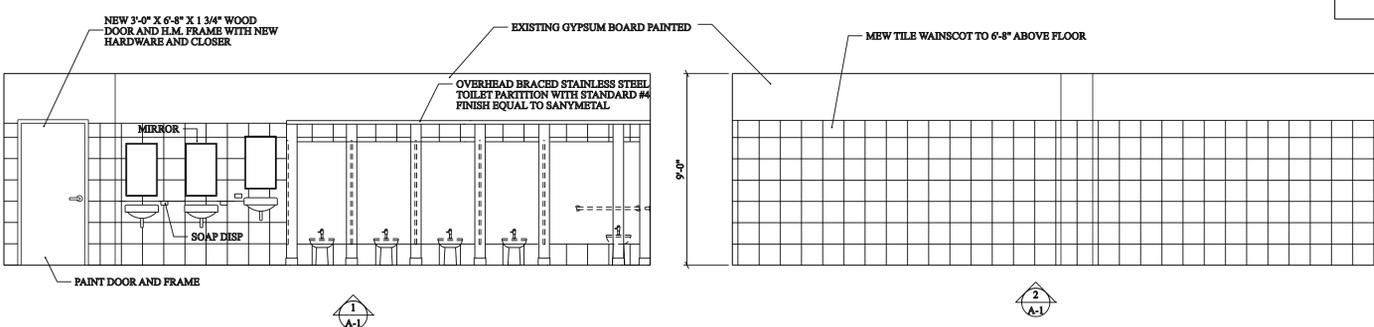

**INTERIOR ELEVATIONS**

SCALE 1/4" = 1'-0"

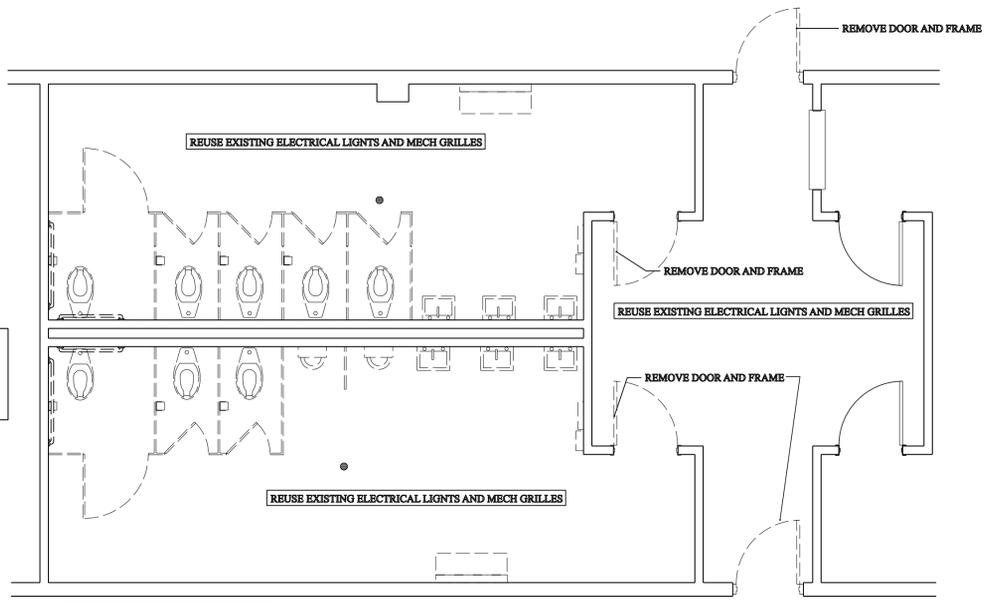

**DEMOLITION FLOOR PLAN**

SCALE 1/4" = 1'-0"

**ITEMS TO BE REMOVED:**  
FLOOR TILE (VCT) AND BASE  
CEILING TILE AND GRID  
PLUMBING FIXTURES  
TOILET PARTITIONS  
TOILET ACCESSORIES  
DESIGNATED DOORS AND FRAMES

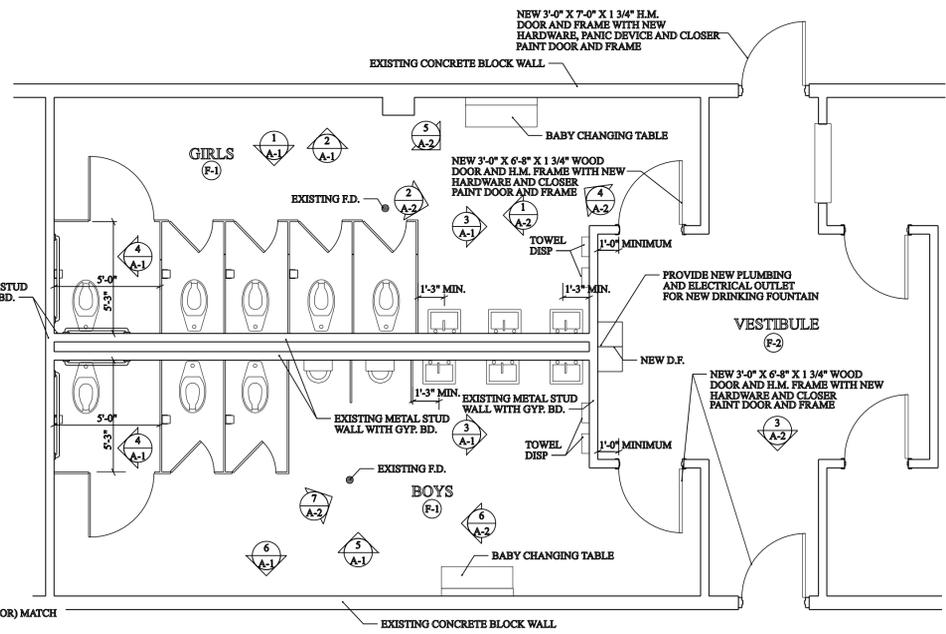

**FLOOR PLAN**

SCALE 1/4" = 1'-0"

**FINISH SCHEDULE**

- (F-1) FLOOR - NEW TILE (ALLOW \$12 PER S.F. INSTALLED)  
WAINSCOT - NEW TILE (ALLOW \$12 PER S.F. INSTALLED)  
THINSET OVER EXISTING GYPSUM BOARD  
WALLS - NEW PAINT ON EXISTING GYP. BD.  
CEILING - NEW 2 X 2 ACOUSTICAL TILE AND GRID (9'-0" ABOVE FLOOR) MATCH EXISTING TILE AND GRID
- (F-2) FLOOR - NEW TILE (ALLOW \$12 PER S.F. INSTALLED)  
BASE - NEW TILE (6" HIGH)  
WAINSCOT - NONE  
WALLS - NEW PAINT ON EXISTING GYP. BD.  
CEILING - NEW 2 X 2 ACOUSTICAL TILE AND GRID (9'-0" ABOVE FLOOR) MATCH EXISTING TILE AND GRID

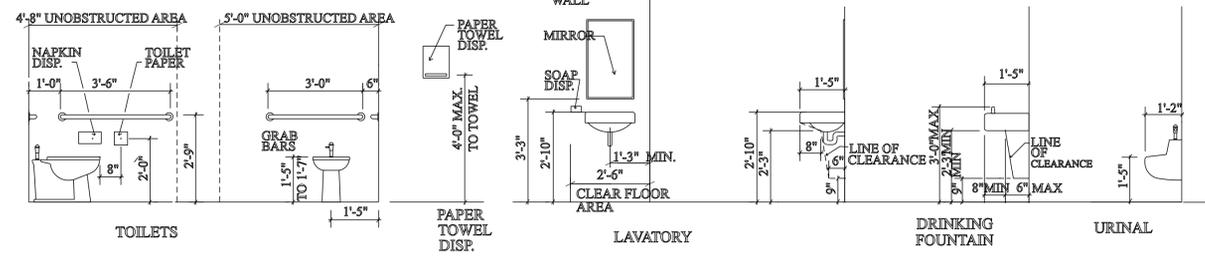

**TYPICAL ADA MOUNTING HEIGHTS**

SCALE 3/8" = 1'-0"



1  
A-2



2  
A-2

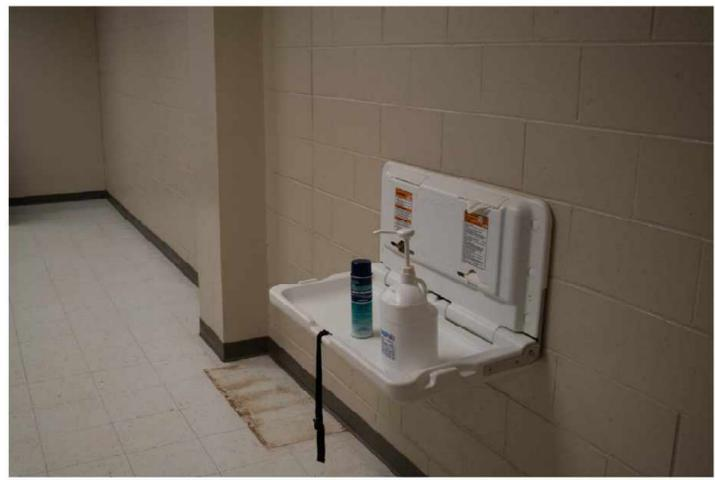

4  
A-2



5  
A-2



6  
A-2



7  
A-2

PHOTOS OF EXISTING CONDITIONS

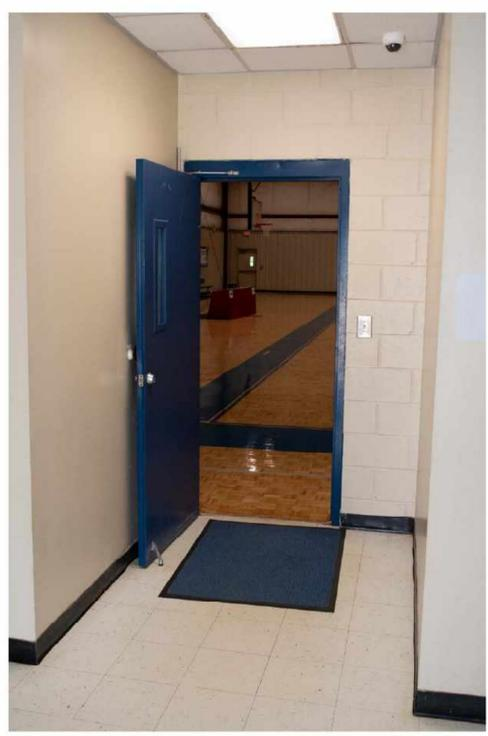

3  
A-2

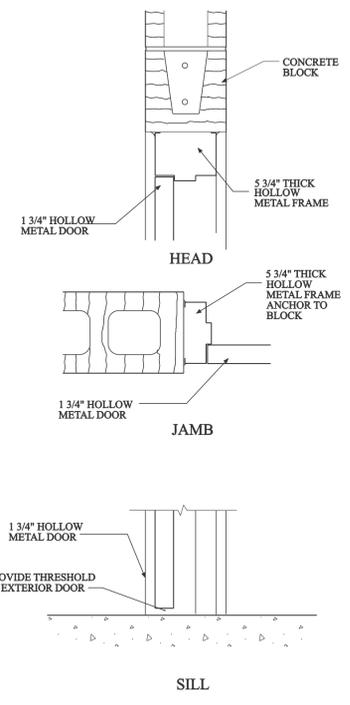

TYP. SECT. AT H.M. DOOR AND FRAME  
SCALE 1 1/2" = 1'-0"

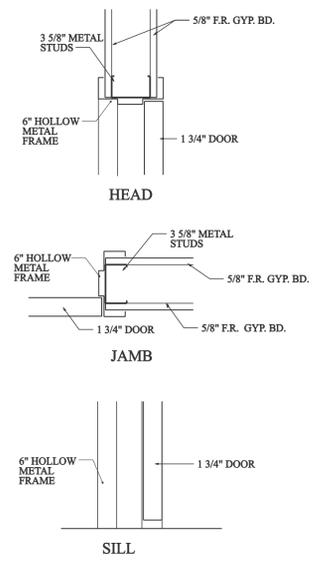

TYP. SECT. AT WOOD DOOR AND H.M. FRAME  
SCALE 1 1/2" = 1'-0"



Photos of existing hallway



Photos of existing ceiling

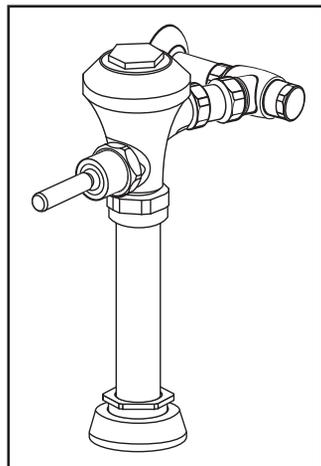

**GENERAL DESCRIPTION:**

Manual Diaphragm-Type Water Closet Flush Valve for floor-mounted or wall-hung 1-1/2" top spud bowls.

**PRODUCT FEATURES:**

- Patent-pending DynaClean™ wiper spring technology significantly reduces maintenance and downtime.
- Self-cleaning wiper spring cleans the refill orifice with every flush; prevents valve run-on from clogging
- Prevents costly excess water usage and potential flooding
- Premium EvoLast™ material is chlorine and chloramine resistant to prevent premature deterioration and failure
- Delivers consistent flushing performance and water savings over time
- Dezincification-resistant brass alloy withstands the most severe water conditions
- Non-hold open handle provides automatic shut-off
- High back pressure vacuum breaker prevents dripping
- Adjustable tailpiece for rough-in flexibility
- Can be installed left or right handed
- No external volume adjustment
- ADA compliant

**MODEL NUMBER:**



☐ **6147121.002** Flush Valve for 1-1/2" top spud bowl, 11-1/2" Supply C\L to top of bowl, 1.28 gpf/4.8 Lpf



☐ **6147122.002** Flush Valve for 1-1/2" top spud bowl, 27" Supply C\L to top of bowl, 1.28 gpf/4.8 Lpf

**OPERATING PRESSURE:**

25 psi (flowing)-80 psi (static)

**FLOW REQUIREMENT:**

25gpm (94.6 L/min.)

**INCLUDES:**

- 1" I.P.S. angle stop with back-flow prevention and vandal-resistant cap
- Sweat solder kit including cover tube and wall flange
- High back pressure vacuum breaker with down tube
- Spud coupling & flange for 1-1/2" top spud

**ACCESSORIES:**

- Split ring pipe supports (2-1/2" & 6" C-E)

**TYPICAL WATER CLOSET INSTALLATION:  
AFWALL™ TOILET SHOWN**

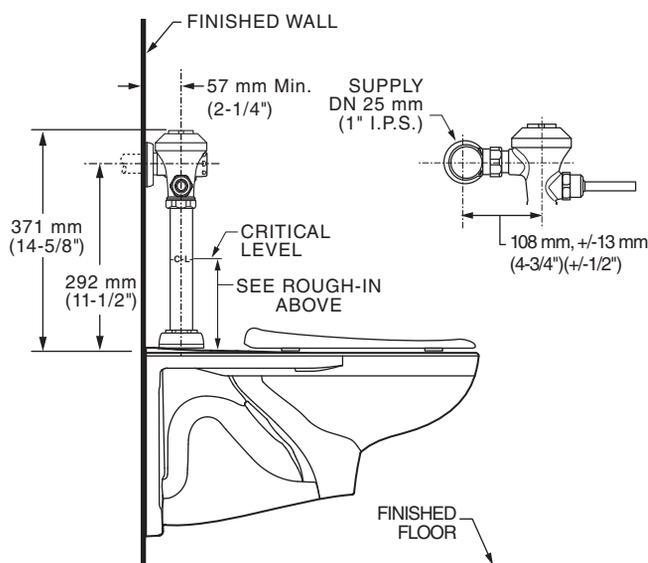

**RECOMMENDED SPECIFICATION:**

Manual toilet flush valve shall feature self-cleaning diaphragm valve with integral DynaClean wiper spring in bypass orifice to prevent clogging. Advanced EvoLast diaphragm provides superior chlorine-resistance. Includes dezincification-resistant cast brass valve body with chrome finish. Includes sweat solder kit with wall flange and cover tube. Angle stop with back-flow protection and vandal-resistant stop cap. High back pressure vacuum breaker included. 1.28 gpf / 4.8 Lpf Flush valve shall be American Standard Model # 6147.12 .002.

**LISTINGS:**

- ASSE 1037
- ANSI/ASME A112.19.2
- ADA Compliant

WC1 & WC2

**Roughing-in Dimensions**

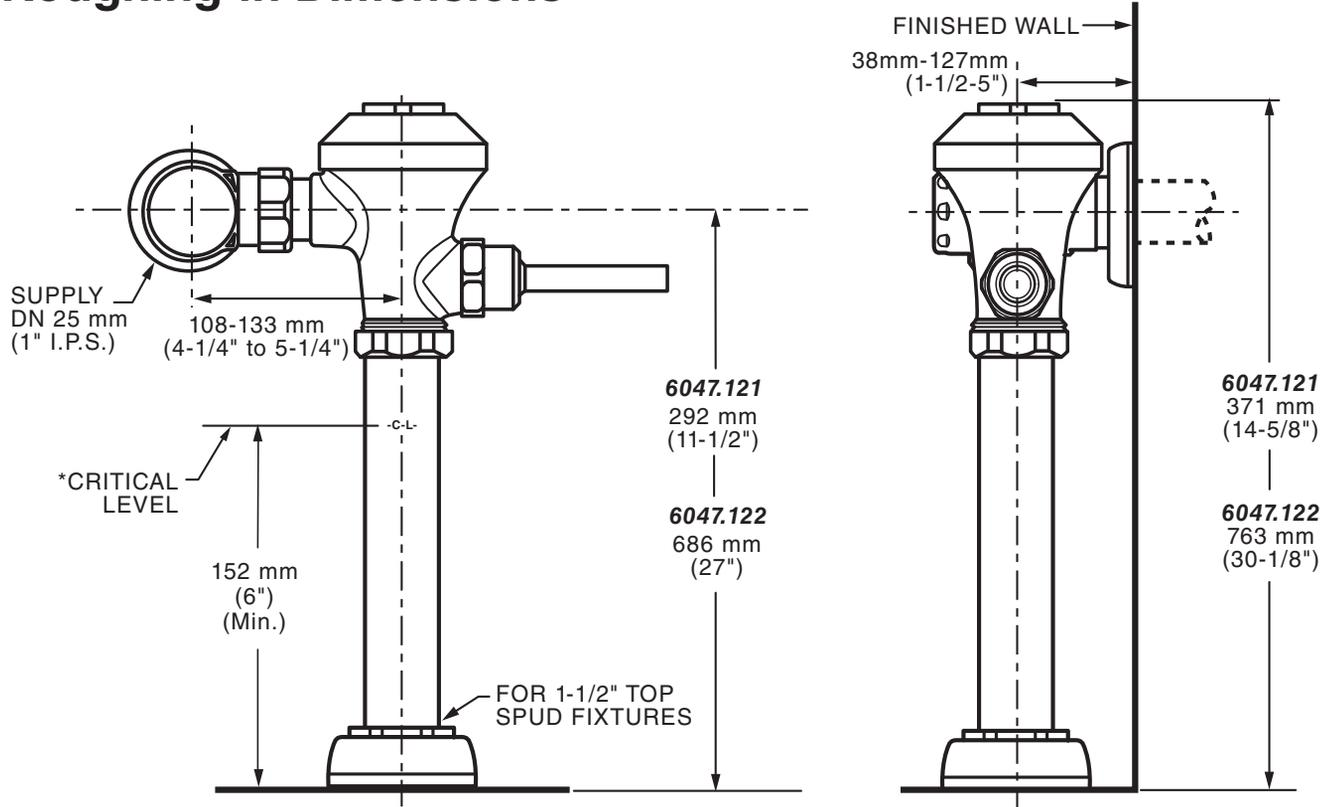

\*Note: The Critical Line (-C-L-) on Vacuum Breaker must typically be a minimum of 6" (152 mm) above fixture. Consult Codes for details.

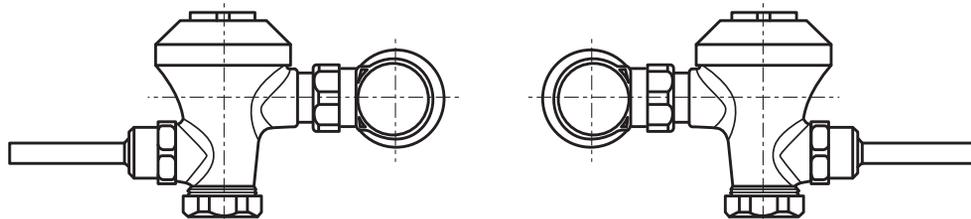

**Left or Right Hand Installation**

# 1655CT / 1655SSCT

COMMERCIAL EXTRA HEAVY-DUTY  
PLASTIC TOILET SEAT

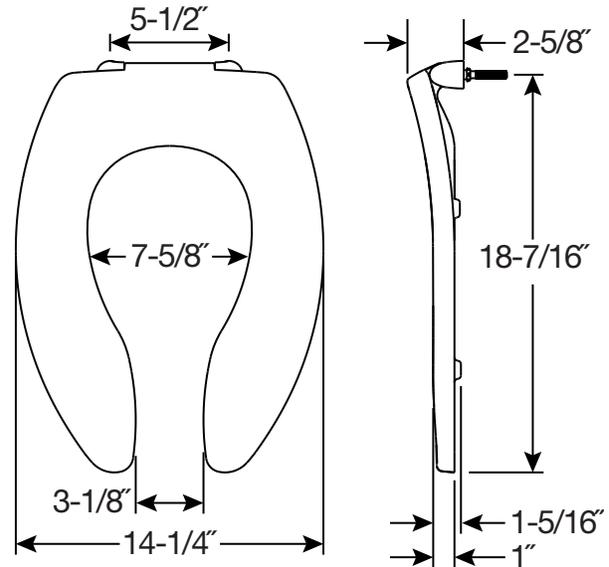

## FEATURES:

- **STA-TITE® Commercial Fastening System™**  
Eliminates callbacks for loosened seats

## SPECIFICATIONS:

**Size:** Elongated

**Material:** Plastic

**Style:** Open Front less Cover

**Ring Bumpers:** Four

**Hinges:** Plastic Non Self-Sustaining Check Hinges (1655CT) or Self-Sustaining Check Hinges (1655SSCT) with Non-Corroding 300 Series Stainless Steel Posts and Pintles

**Hardware:** STA-TITE® Commercial Fastening System™

**Codes & Standards:**



Complies with  
IAPMO/ANSI Z124.5  
Performance Standards  
Heavy-Duty Commercial



Proudly Made in the USA

Eco-Friendly



# Willoughby Industries - Security Products



## ETF-1490-OW Stainless Steel Floor Outlet Off-Wall Mounted Siphon Jet Series Toilet



**IN COMPLIANCE  
WITH A.D.A. 2010**

**\*\* USE "HC" SUFFIX FOR  
18" A.F.F. SEAT HEIGHT**

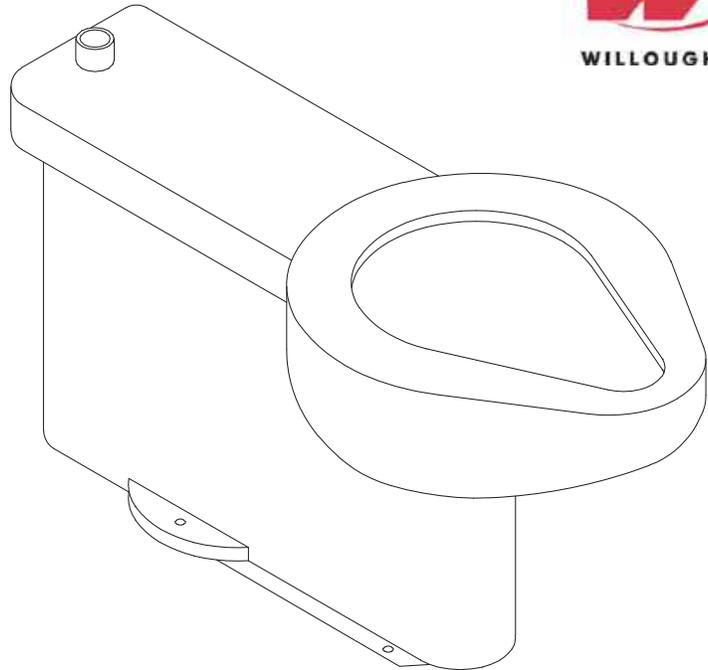

**(1.6 GPF UNIT W/ 15" A.F.F.  
SEAT HEIGHT\* SHOWN)**  
*(Unit may be shown with optional features)*

To specify fixture and accessories, use the Model Number and Options page.

Example: To specify a Floor Outlet, Off Wall Mounted, Siphon Jet Series Toilet with top spud, standard 15" seat height, 1.6 GPF, floor outlet waste connection, high polish seat, and toilet shipping cover

Use the following Willoughby Model Number:  
**ETF-1490-OW-TS-1.6-TW4-HPS-TSC**

## Recommended Specifications

Stainless Steel, Floor Outlet, Off-Wall Mounted, Siphon Jet Series Toilet shall be: Willoughby Model No. **ETF-1490-OW**  
(Select from model number and options list on next page)

Fixture shall be fabricated from 14 gauge, type 304 stainless steel. The construction shall be all welded, with exposed stainless surfaces polished to a #4 satin finish.

Standard toilet shall include:

- Elongated toilet bowl with contoured seat
- Integral crevice-free self-draining flushing rim with positive afterfill
- Fully enclosed 2-3/8" O.D. trap which shall maintain a minimum 2" seal and pass a 2" ball
- Bead blast finish bowl interior

Toilet shall be siphon jet type, requiring 35 PSI minimum flushing pressure. Model shall meet the requirements of ASME A112.19.3/CSA B45.4.

Fixture shall withstand loadings of 5,000 lbs. without permanent damage.

Anchoring shall be through the floor (anchoring hardware provided by others).

Unit requires no chase area for installation and maintenance.

**Note:** Unit will pass a 2" ball.

**Note:** Fixture should only be used with a listed high-efficiency flushometer to ensure the complete system meets the requirements of WaterSense.



**WARNING:** Cancer and Reproductive Harm

- [www.P65Warnings.ca.gov](http://www.P65Warnings.ca.gov)



MADE IN THE U.S.A.

visit our website at [www.willoughby-ind.com](http://www.willoughby-ind.com)  
5105 West 78th Street • Indianapolis, IN. 46268  
(317) 875-0830 • Fax: (317) 875-0837 • (800) 428-4065

# MODEL NUMBER AND OPTIONS:

**1.) Base Model Number:**

- ETF-1490-OW Stainless Steel, Floor Outlet, Off-Wall Mounted, Siphon Jet Series Toilet

**2.) Inlet Location:**

- TS Top Spud

**3.) Toilet Seat Height:**

- 15" Seat Height (Standard) **WC1**
- HC 18" Seat Height, Handicap-ADA Compliant **WC2**

**4.) Flush Valve GPF (Must Specify):**

- 1.28 GPF HET (4.8 Lpf) (WaterSense Labeled)
- 1.6 GPF ULF (6.0 Lpf)
- 3.5 GPF (13.2 Lpf)

**5.) Toilet Waste:**

- GWC Gasketed Waste Connection (Standard)
- TW4 Floor Outlet Waste Connection

**6.) Other Options:**

- HS Hinged White Plastic Seat (No Cover, not recommended for Maximum Security/Ligature-resistant use)
- DC Decorator Color (Fixture exterior only - White)
- HPS High Polish Seat
- TSC Toilet Shipping Cover
- RTH1 Wall Mounted Recessed Tissue Holder (Rear Mounted, Requires Accessible Chase)
- RTH2 Wall Mounted Recessed Tissue Holder (Front Mounted, 4-1/2" Depth)
- Other \_\_\_\_\_
- Other \_\_\_\_\_

Approved For Manufacturing By: \_\_\_\_\_ Date: \_\_\_\_\_ Company: \_\_\_\_\_  
 Wall Thickness: \_\_\_\_\_ Wall Type: \_\_\_\_\_

**VERIFY ALL DIMENSIONS WITH FACTORY PRIOR TO ROUGH-IN**  
 WILLOUGHBY RESERVES THE RIGHT TO MAKE CHANGES IN DESIGN AND DIMENSIONS WITHOUT FORMAL NOTICE AND WITHOUT INCURRING OBLIGATION.

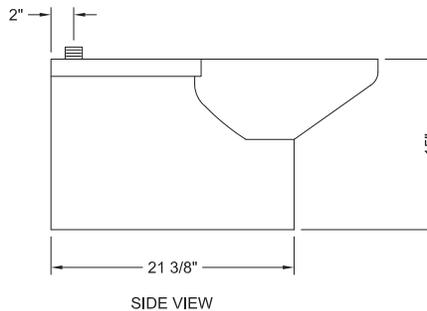
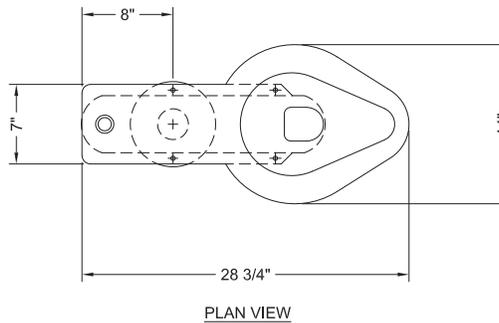

**visit our website at [www.willoughby-ind.com](http://www.willoughby-ind.com)**  
 5105 West 78th Street • Indianapolis, IN. 46268  
 (317) 875-0830 • Fax: (317) 875-0837 • (800) 428-4065



MADE IN THE U.S.A.



**GENERAL DESCRIPTION:**

Metering centerset conventional spout faucet. Vandal-resistant solid brass construction. Easy-push handles. Water conserving, pressure compensating 0.5 GPM vandal-resistant non-aerated spray. Factory set for a maximum of 0.083 gallon flow per activation. Replaceable valve cartridge. Adjustable flow cycle.

**MODEL NUMBER:**

- ❑ **1340.227** Cast centerset, 0.5 GPM pressure compensating, vandal-resistant non-aerated spray.

**PRODUCT FEATURES:**

- **Meets CALGreen:** Delivers 0.083 gallons per cycle which is a 59% water savings from CALGreen baseline.
- **Pressure Compensating Non-Aerated Spray:** Provides a constant water flow of 0.5 gpm throughout the pressure range.
- **Vandal-Resistant Brass Construction and Spray:** Durable - Excellent in high use applications.
- **Automatic Shut-off:** Stops water and energy waste. Ideal for public restrooms where uncontrolled water usage is costly.
- **Meets ADA Standard:** Requires less than 5 lbs. of operating force to initiate flow per ANSI A117.1.
- **Adjustable Flow Cycle**
- **Replaceable Valve Cartridge:** Facilitates simple replacement.
- **Hot/Cold Button Indicators**
- **Lead Free:** Faucet contains ≤ 0.25% total lead content by weighted average.
- **Minimum Operating Pressure:** 20 psi

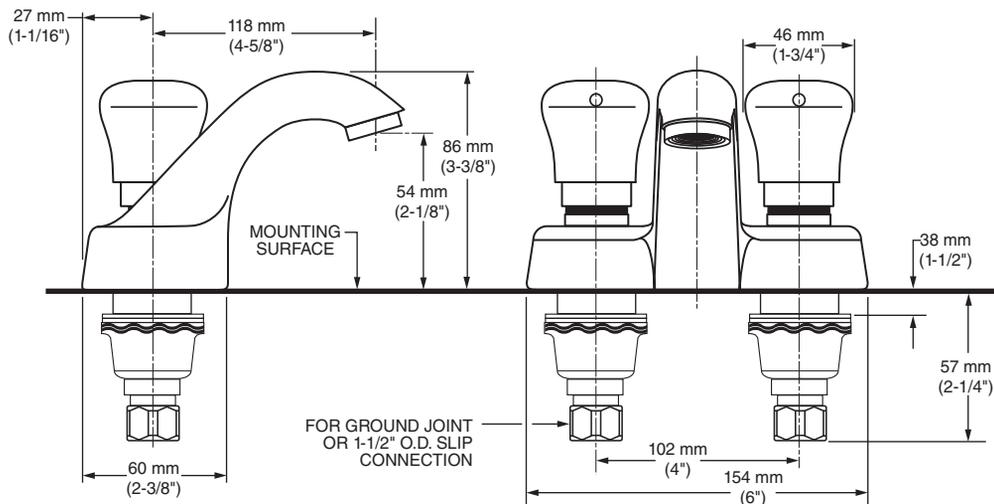

**SUGGESTED SPECIFICATION**

Metering faucet shall feature a vandal-resistant brass construction with a replaceable valve cartridge and an adjustable flow cycle. Shall also feature a water-conserving, pressure compensating 0.5 gpm/1.9 L/min vandal-resistant non-aerated spray. Factory set to deliver 0.083 gallons per cycle to meet CALGreen. Push button activator shall meet ANSI A117.1 Standard. Fitting shall be American Standard Model # 1340.227.002.

**CODES AND STANDARDS**

These products meet or exceed the following codes and standards:

- ANSI A117.1**
- ASME A112.18.1**
- CSA B 125**
- NSF 61/Section 9 and Annex G**
- CALGreen**

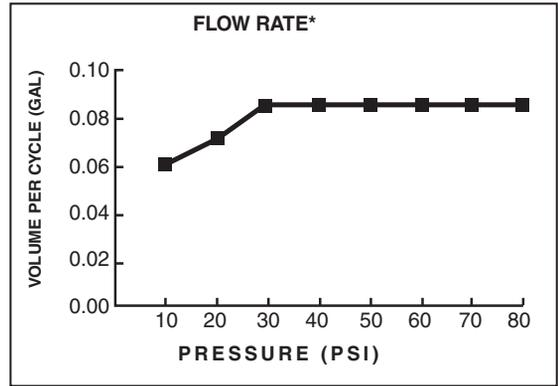

 Meets the American Disabilities Act Guidelines  
**ANSI A117.1** Requirements for the accessible  
and usable building facilities - check local codes.



# ES-1015-HC

## Handicap

## Stainless Steel

## Commercial Lavatory

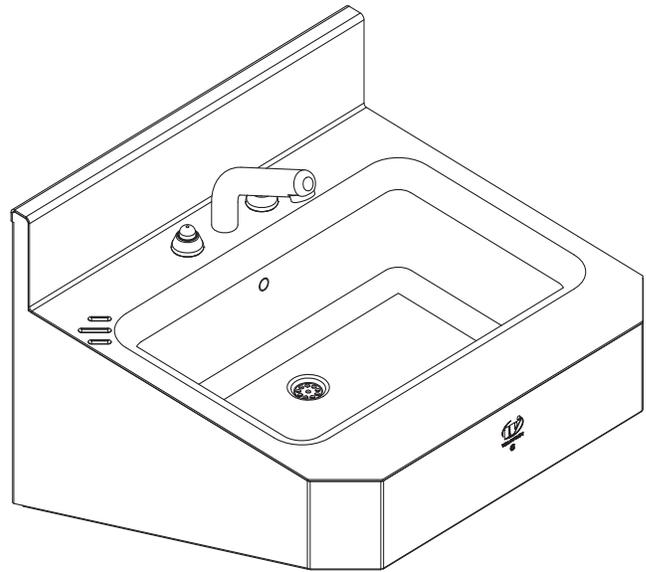

*(Unit may be shown with optional features)*

To specify fixture and accessories, use the Model Number and Options page.

Example: To specify a Handicap Stainless Steel Commercial Lavatory with deck mounted spout, dual temp. pneumatic metering valves, standard ligature-resistant pneumatic push buttons, standard lav. overflow vent, and chrome plated removable P-trap

Use the following Willoughby Model Number:  
**ES-1015-HC-DMS-PML2-PBH-OV-TT**

## Recommended Specifications

Handicap Stainless Steel Commercial Lavatory shall be:  
Willoughby Model No. **ES-1015-HC**  
(select from model number and options list on next page)

Fixture shall be fabricated from 16 gauge, Type 304 stainless steel. The construction is all-welded with exposed stainless surfaces polished to a #3 satin finish.

Standard lavatory shall include:

- Rectangular-shaped bowl, 14-1/2" x 9-1/2" x 4-3/8" deep
- Fast drain with overflow vent
- 4" long, Ø1-1/2" tailpiece
- Self-draining soap dish
- 0.5 GPM flow rate

### Mounting:

Anchoring shall be from the front with Z-clip and anchoring holes provided. Anchoring hardware by others. Wall requires adequate backing to support lavatory. Unit requires no chase area for installation and maintenance.

### ADA, TAS, and ANSI Compliant:

When the lavatory is mounted at the standard 34" adult rim height, it complies with applicable ADA, TAS, and ANSI Z124.3 and Z124.6 accessibility guidelines.

*Note:* Plug-in transformer must be used with a ground fault interrupter (GFCI) receptacle to prevent possible electrical shock.



**WARNING:** Cancer and Reproductive Harm

- [www.P65Warnings.ca.gov](http://www.P65Warnings.ca.gov)



MADE IN THE U.S.A.

visit our website at [www.willoughby-ind.com](http://www.willoughby-ind.com)  
5105 West 78th Street • Indianapolis, IN. 46268  
(317) 875-0830 • Fax: (317) 875-0837 • (800) 428-4065

## 1.) Lavatory Model:

- ES-1015-HC** 18" Handicap Stainless Steel Commercial Lavatory

## 2.) Spout/Bubbler Selection:

- DMS Deck Mounted Spout  
 DMBH Deck Mounted Hemispherical Bubbler

## 3.) Valve Selection:

- NV** No Valve, No Spout / Bubbler- Faucet by Others (Select Hole Punching if needed)  
 PSL1 Single Temp. Pneumatic Non-metering  
 PSL2 Dual Temp. Pneumatic Non-metering  
 PML1 Single Temp. Pneumatic Metering  
 PML2 Dual Temp. Pneumatic Metering  
 E1L1 Single Temp. Electronic (w/ Pneutronic Control)\*  
 E1L2 Dual Temp. Electronic (w/ Pneutronic Control)\*

## 4.) Valve Actuation:

- PBH Ligature-resistant Pneumatic Push Buttons  
 PZPB Ligature-resistant Piezo Electronic Push Buttons\*

## 5.) Hole Punching Selection (Faucet by Others):

- 4CC** 4" Centerset, Ø1-1/4" Holes (3 Holes)  
 8CC 8" Centerset, Ø1-1/4" Holes (3 Holes)  
 1CC Center Shank, (1) Ø1-1/4" Hole (1 Hole)

## 6.) Lavatory Waste Options:

- TT Chrome Plated Removable P-Trap  
 TE Trap Enclosure  
 OV Overflow Vent (Standard)

## 7.) Other Options:

- TMV In-line Thermostatic Mixing Valve  
 DC Decorator Color (Fixture exterior only - White)  
 TF24H Hard-wired Transformer, 110VAC to 24VAC\* (Standard)  
 TF24P Plug-in Transformer, 110VAC to 24VAC\*  
 Other \_\_\_\_\_  
 Other \_\_\_\_\_

## 8.) Electronic Controls\* (Must Use Electronic Push Button):

- WUCC-3010  Pneutronic  
 (The WUCC-3010 Control can be used to pair a Lavatory with a Toilet)  
 \*(Req. 110V power through ground fault interrupter (GFCI) receptacle)

Approved For Manufacturing By: \_\_\_\_\_ Date: \_\_\_\_\_ Company: \_\_\_\_\_  
 Wall Thickness: \_\_\_\_\_ Wall Type: \_\_\_\_\_

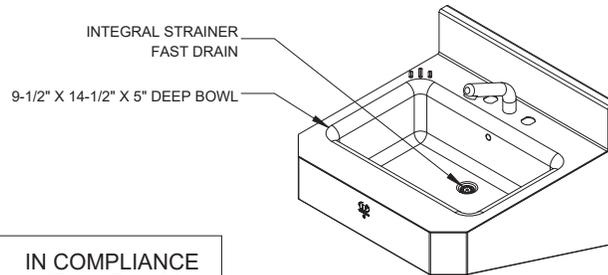
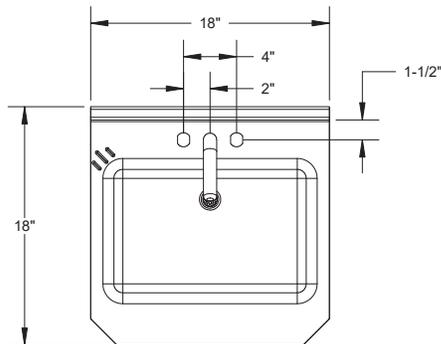

VERIFY ALL DIMENSIONS WITH FACTORY PRIOR TO ROUGH-IN  
 WILLOUGHBY RESERVES THE RIGHT TO MAKE CHANGES IN DESIGN AND DIMENSIONS WITHOUT FORMAL NOTICE AND WITHOUT INCURRING OBLIGATION.

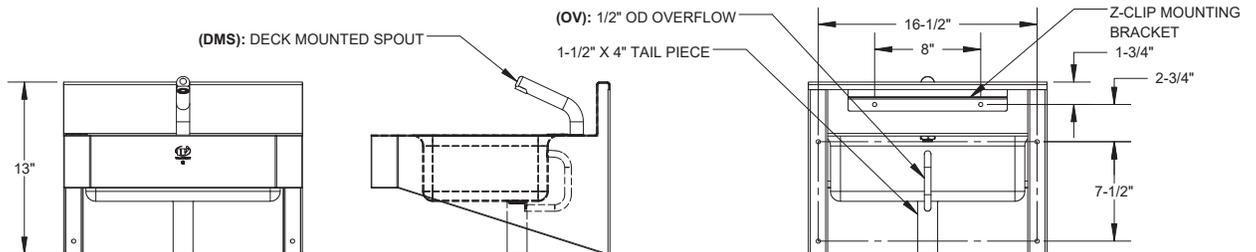

visit our website at [www.willoughby-ind.com](http://www.willoughby-ind.com)  
 5105 West 78th Street • Indianapolis, IN. 46268  
 (317) 875-0830 • Fax: (317) 875-0837 • (800) 428-4065



MADE IN THE U.S.A.

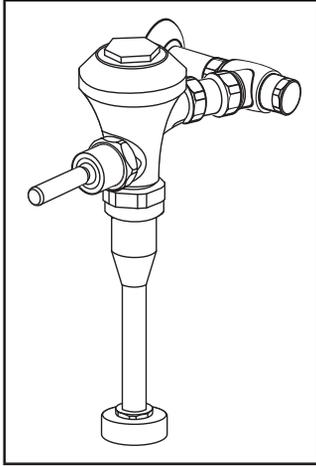

**GENERAL DESCRIPTION:**  
Manual Diaphragm-Type Urinal Flush Valve for 3/4" top spud urinals.

**PRODUCT FEATURES:**

- Patent-pending DynaClean™ wiper spring technology significantly reduces maintenance and downtime.
- Self-cleaning wiper spring cleans the refill orifice with every flush; prevents valve run-on from clogging
- Prevents costly excess water usage and potential flooding
- Premium EvoLast™ material is chlorine and chloramine resistant to prevent premature deterioration and failure
- Delivers consistent flushing performance and water savings over time
- Dezincification-resistant brass alloy withstands the most severe water conditions
- Non-hold open handle provides automatic shut-off
- High back pressure vacuum breaker prevents dripping
- Adjustable tailpiece for rough-in flexibility
- Can be installed left or right handed
- No external volume adjustment
- ADA compliant

**MODEL NUMBER:**



❑ **6145013.002** Flush Valve for 3/4" top spud urinal, 11-1/2" rough-in, 0.125 gpf/0.5 Lpf



❑ **6145051.002** Flush Valve for 3/4" top spud urinal, 11-1/2" rough-in, 0.5 gpf/0.9 Lpf

❑ **6145101.002** Flush Valve for 3/4" top spud urinal, 11-1/2" rough-in, 1.0 gpf/3.8 Lpf

**OPERATING PRESSURE:**  
20 psi (flowing)-80 psi (static)

**FLOW REQUIREMENT:**  
10 gpm (37.9 L/min.)

**INCLUDES:**

- 3/4" I.P.S. angle stop with back-flow prevention and vandal-resistant cap
- Sweat solder kit including cover tube and wall flange
- High back pressure vacuum breaker with down tube
- Spud coupling & flange for 3/4" top spud

**TYPICAL URINAL INSTALLATION:  
WASHBROOK URINAL SHOWN**

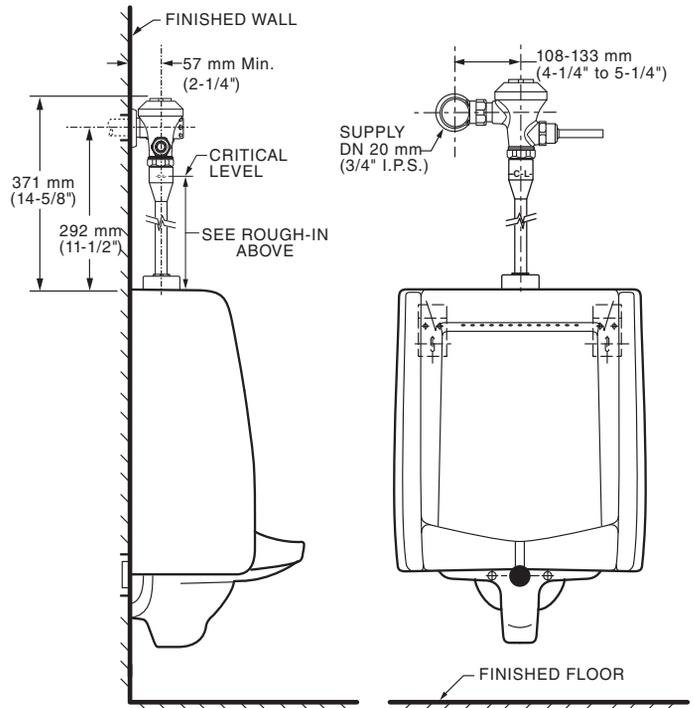

**RECOMMENDED SPECIFICATION:**

Manual urinal flush valve shall feature self-cleaning diaphragm valve with integral DynaClean wiper spring in bypass orifice to prevent clogging. Advanced EvoLast diaphragm provides superior chlorine-resistance. Includes dezincification-resistant cast brass valve body with chrome finish. Includes sweat solder kit with wall flange and cover tube. Angle stop with back-flow protection and vandal-resistant stop cap. High back pressure vacuum breaker included.

**LISTINGS:**

- ASSE 1037
- ANSI/ASME A112.19.2
- ADA Compliant

**Roughing-in Dimensions**

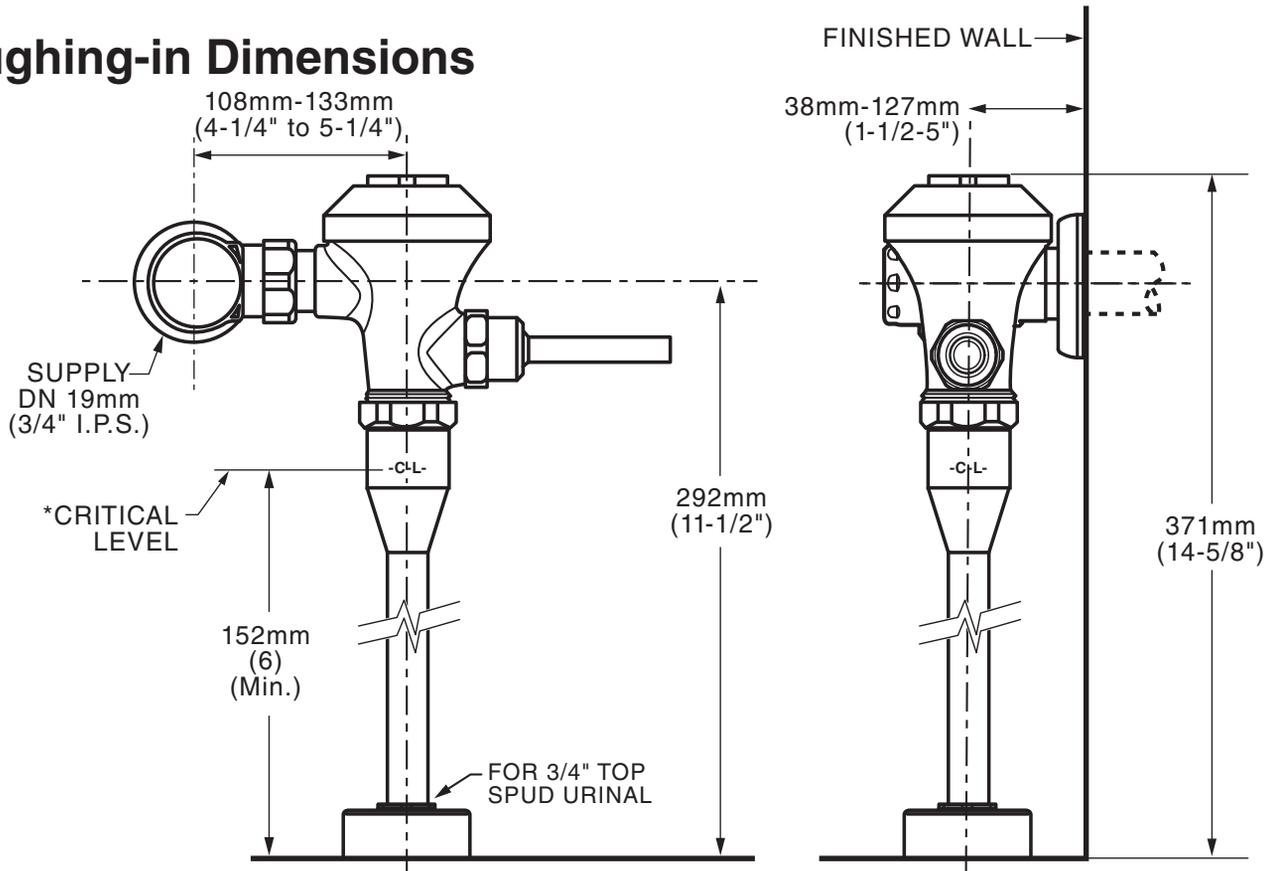

\*Note: The Critical Line (-C-L-) on Vacuum Breaker must typically be a minimum of 6" (152 mm) above fixture. Consult Codes for details.

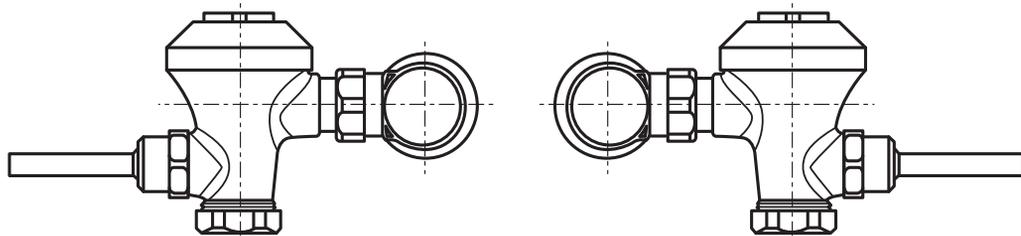

**Left or Right Hand Installation**



## UW-1317-HEU-FA Stainless Steel Single Person Front Mounted ADA-Compliant Contoured Washout Flush High Efficiency Urinal

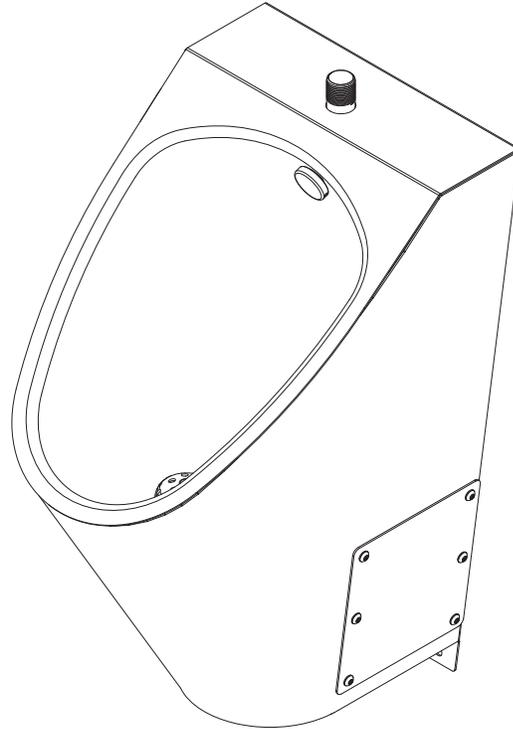

*(Unit may be shown with optional features)*



**IN COMPLIANCE  
WITH A.D.A. 2010**

To specify fixture and accessories, use the Model Number and Options page.

Example: To specify a Stainless Steel, Single Person, Front Mounted, ADA-Compliant, Contoured, Washout Flush, High Efficiency Urinal with top spud, 1/8 GPF, wall template, hydraulic flush valve, and ligature-resistant flush valve cover

Use the following Willoughby Model Number:  
**UW-1317-HEU-FA-TS-0.125-MT-FV-ASFVC**

### Recommended Specifications

Stainless Steel, Single Person, Front Mounted, ADA-Compliant, Contoured, Washout Flush, High Efficiency Urinal shall be: Willoughby Model No. **UW-1317-HEU-FA**  
(Select from model number and options list on next page)

Fixture is fabricated from all 16 GA., Type 304 stainless steel. The construction shall be all-welded with exposed stainless steel surfaces polished to a satin finish. Contoured interior and exterior surfaces for ease of cleaning.

Standard equipment shall include:

- Machined stainless steel flush nozzle
- Beehive strainer
- Removable P-trap with 1-1/2" F.I.P. waste connection
- 3/4" N.P.T. male inlet connection
- Removable access cover

High Efficiency Urinal shall be washout type requiring 1/8 to 1/2 GPF flush valve and 25 PSI minimum flushing pressure. Trap shall be fully enclosed and maintain a 3" seal.

Mounting hardware by others.

Unit requires no chase area for installation and maintenance unless specified with any options requiring an accessible chase.

Urinals mounted at 17" rim height to comply with ANSI, ADA and UFAS accessibility requirements. Please consult local code as compliance is subject to the interpretation and requirements of the local code authority.

**Note:** Fixture should only be used with a listed high-efficiency flushometer to ensure the complete system meets the requirements of WaterSense.



**WARNING:** Cancer and Reproductive Harm

- [www.P65Warnings.ca.gov](http://www.P65Warnings.ca.gov)



MADE IN THE U.S.A.

visit our website at [www.willoughby-ind.com](http://www.willoughby-ind.com)  
5105 West 78th Street • Indianapolis, IN. 46268  
(317) 875-0830 • Fax: (317) 875-0837 • (800) 428-4065

# MODEL NUMBER AND OPTIONS:

UR

**1.) Base Model Number:**

- UW-1317-HEU-FA      Stainless Steel, Single Person, Front Mounted, ADA-Compliant, Contoured, Washout Flush, High Efficiency Urinal

**2.) Inlet Location:**

- BS      Back Spud  
 TS      Top Spud

**3.) Flush Valve GPF (Must Specify):**

- 0.5      GPF (1.9 Lpf) High Efficiency (HEU) (WaterSense Labeled)  
 0.125      GPF (0.4 Lpf) High Efficiency (HEU)

**4.) Options:**

- MT      Wall Template  
 FV      Hydraulic Flush Valve (Includes Actuator)  
 EFV      Electronic Flush Valve (Pick Control)\*  
 EFVP      Electronic Flush Valve w/ (PZPB) Ligature-resistant Piezo Push Button (Pick Control)\*  
 ASUFVC      Ligature-resistant Urinal Flush Valve Cover (Top Spud Only)  
 AP      Flush Valve Access Panel (Allows access to chase mounted flush valve from fixture side)  
 TF24H      Hard-wired Transformer, 110VAC to 24VAC\*  
 TF24P      Plug-in Transformer, 110VAC to 24VAC\*  
 DC      Decorator Color (Fixture exterior only - White)  
 Other \_\_\_\_\_  
 Other \_\_\_\_\_

**5.) Electronic Controls\* (Must Use Electronic Flush Valve):**

- WUFC-4000       Pneumatic       WMSII  
 \*(Req. 110V power through ground fault interrupter (GFCI) receptacle)

Approved For Manufacturing By: \_\_\_\_\_ Date: \_\_\_\_\_ Company: \_\_\_\_\_  
 Wall Thickness: \_\_\_\_\_ Wall Type: \_\_\_\_\_

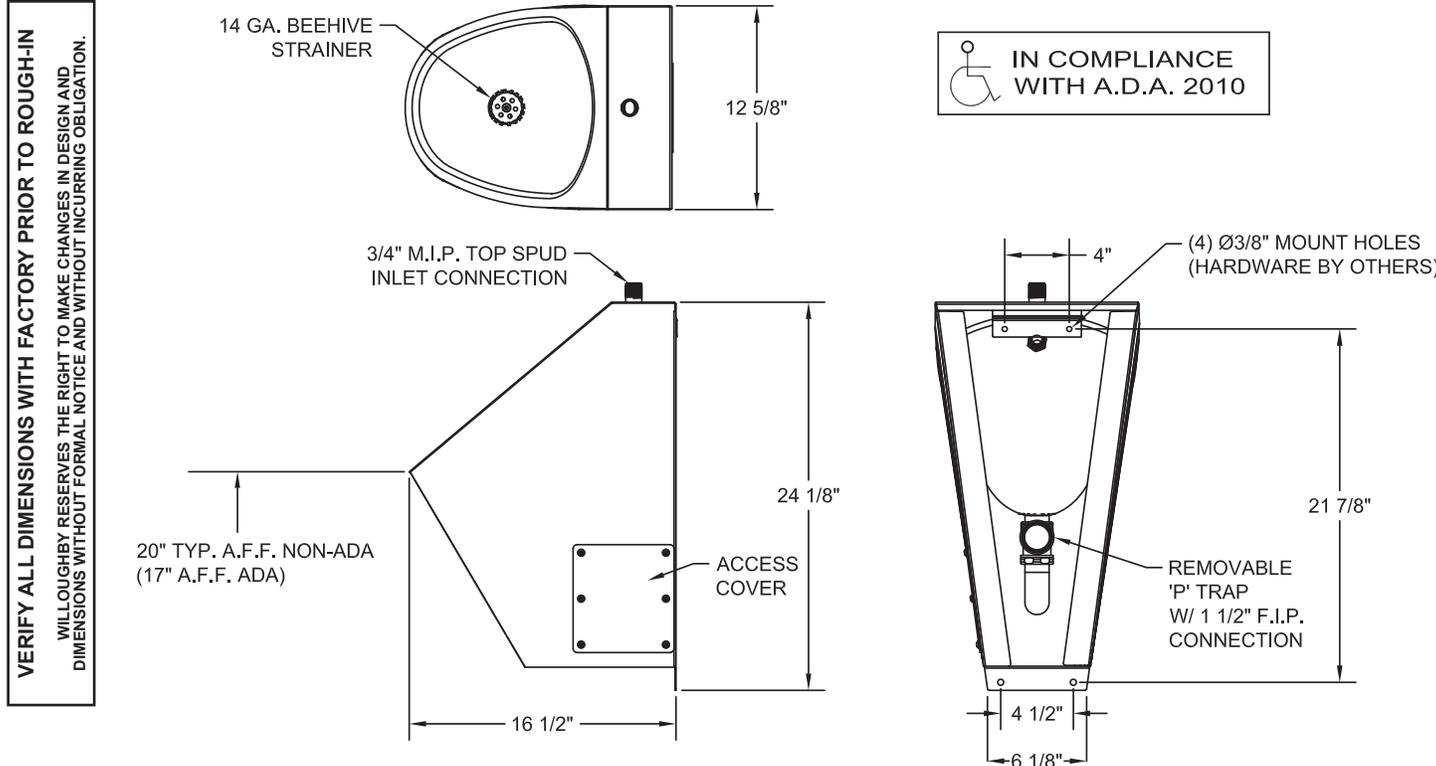

visit our website at [www.willoughby-ind.com](http://www.willoughby-ind.com)  
 5105 West 78th Street • Indianapolis, IN. 46268  
 (317) 875-0830 • Fax: (317) 875-0837 • (800) 428-4065



MADE IN THE U.S.A.

**PRODUCT SPECIFICATIONS**

Elkay ezH2O® Bottle Filling Station, & Bi-Level High Efficiency Vandal-Resistant Cooler, Non-Filtered Refrigerated Stainless. Chilling Capacity of 8.0 GPH (gallons per hour) of 50° F drinking water, based on 80° F inlet water and 90° F ambient, per ASHRAE 18 testing. Features shall include Antimicrobial, Green Ticker™, Hands Free, High Efficiency, Laminar Flow, Real Drain, Vandal Resistant. Furnished with Vandal Resistant StreamSaver™ bubbler. Electronic Bottle Filler Sensor with Mechanical Front Bubbler Button activation. Product shall be Wall Mount (On Wall), for Indoor applications, serving 2 station(s). Unit shall be certified to UL 399 and CAN/CSA C22.2 No. 120. Unit shall be lead-free design which is certified to NSF/ANSI 61 & 372 (lead free) and meets Federal and State low-lead requirements.



<b>Special Features:</b>	Antimicrobial, Green Ticker™, Hands Free, High Efficiency, Laminar Flow, Real Drain, Vandal Resistant
<b>Finish:</b>	Stainless Steel
<b>Power:</b>	115V/60Hz
<b>Bubbler Style:</b>	Vandal Resistant StreamSaver™
<b>Activation by:</b>	Electronic Bottle Filler Sensor with Mechanical Front Bubbler Button
<b>Mounting Type:</b>	Wall Mount (On Wall)
<b>Chilling Capacity*:</b>	8.0 GPH
<b>Full Load Amps</b>	1
<b>Rated Watts:</b>	260
<b>Dimensions (L x W x H):</b>	36-1/8" x 18-5/8" x 46-1/4"
<b>Approx. Shipping Weight:</b>	112 lbs.
<b>Installation Location:</b>	Indoor
<b>No. of Stations Served:</b>	2
*Based on 80° F inlet water & 90° F ambient air temp for 50° F chilled drinking water.	

- Mechanically-Activated bubbler continues to supply water in event of service disruptions.
- High-performance compressor and insulation greatly reduce energy consumption.
- Green Ticker: Informs user of number of 20 oz. plastic water bottles saved from waste.
- Laminar flow provides clean fill with minimal splash.
- Silver Ion Antimicrobial protection on key plastic components to inhibit the growth of mold and mildew.
- Real Drain System eliminates standing water.

**COOLING SYSTEM**

- Compressor: Hermetically-sealed, reciprocating type, single phase. Sealed-in lifetime lubrication.
- Condenser: Fan cooled, copper tube with aluminum fins. Fan motor is permanently lubricated.

PART: \_\_\_\_\_ QTY: \_\_\_\_\_  
 PROJECT: \_\_\_\_\_  
 CONTACT: \_\_\_\_\_  
 DATE: \_\_\_\_\_  
 NOTES: \_\_\_\_\_  
 APPROVAL: \_\_\_\_\_

AMERICAN PRIDE. A LIFETIME TRADITION. Like your family, the Elkay family has values and traditions that endure. For almost a century, Elkay has been a family-owned and operated company, providing thousands of jobs that support our families and communities.



**Included with Product:** Water Cooler (VRCGRNTL8WSC), Bottle Filler (EZWSR)

▼ Ships in multiple boxes.

**PRODUCT COMPLIANCE**

- ADA & ICC A117.1
- ASME A112.19.3/CSA B45.4
- Buy American Act
- CAN/CSA C22.2 No. 120
- GreenSpec®
- NSF/ANSI 61 & 372 (lead free)
- UL 399



Complies with ADA & ICC A117.1 accessibility requirements when installed according to the requirements outlined in these standards. Installation may require additional components and/or construction features to be fully compliant. Consult the local Authority Having Jurisdiction if necessary.

[Installation Instructions \(PDF\)](#)

**5 Year Limited Warranty** on the refrigeration system of the unit. Electrical components and water system are warranted for 12 months from date of installation. **Warranty pertains to drinking water applications only. Non-drinking water applications are not covered under warranty.**

[Warranty \(PDF\)](#)

**OPTIONAL ACCESSORIES**

EW3000 - Elkay WaterSentry Plus Filter System Kit (Bottle Fillers)
98324C - Accessory - Cane Apron for HAC, HVR, EMABF & VRC Models (Stainless)

*In keeping with our policy of continuing product improvement, Elkay reserves the right to change product specifications without notice. Please visit elkay.com for the most current version of Elkay product specification sheets. This specification describes an Elkay product with design, quality, and functional benefits to the user. When making a comparison of other producers' offerings, be certain these features are not overlooked.*

- Cooling Unit: Combination tube-tank type. Continuous copper tubing with is fully insulated with EPS foam that meets UL requirements for self-extinguishing material.
- Refrigerant Control: Refrigerant HFC-134a is controlled by accurately calibrated capillary tube for positively trouble-free operation.
- Temperature Control: Easily accessible enclosed adjustable thermostat is factory preset. Requires no adjustment other than for altitude requirements.

*In keeping with our policy of continuing product improvement, Elkay reserves the right to change product specifications without notice. Please visit [elkay.com](http://elkay.com) for the most current version of Elkay product specification sheets. This specification describes an Elkay product with design, quality, and functional benefits to the user. When making a comparison of other producers' offerings, be certain these features are not overlooked.*

### IMPORTANT! INSTALLER PLEASE NOTE :

This water cooler has been designed and built to provide water to the user which has not been altered by materials in the cooler waterways. The grounding of electrical equipment such as telephone, computer, etc. to water lines is a common procedure. The grounding may be in the building but may also occur away from the building. This grounding can cause electrical feedback into a water cooler creating an electrolysis which creates a metallic taste or causes an increase in the metal content of the water. This condition is avoidable by installing the cooler using the proper materials as shown below.

### NOTICE

This water cooler must be connected to the water supply using a dielectric coupling. The cooler is furnished with a non-metallic strainer which meets this requirement. The drain trap which is provided by the installer should also be plastic to completely isolate the cooler from the building plumbing system. Bottle filler unit on bracket attached to wall by 6 holes (as shown). Water and electrical will connect through pre-punched hole in basin. These products are designed to operate on 20 psi to 105 psi supply line pressure. Simultaneous operation of both bubblers on a bi-level unit may not be possible depending on water supply pressure. If simultaneous operation is desired, please ensure a minimum of 50 psi supply.

### OPERATION OF QUICK CONNECT FITTINGS

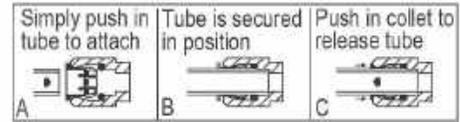

Pushing tube in before pulling it out helps to release tube

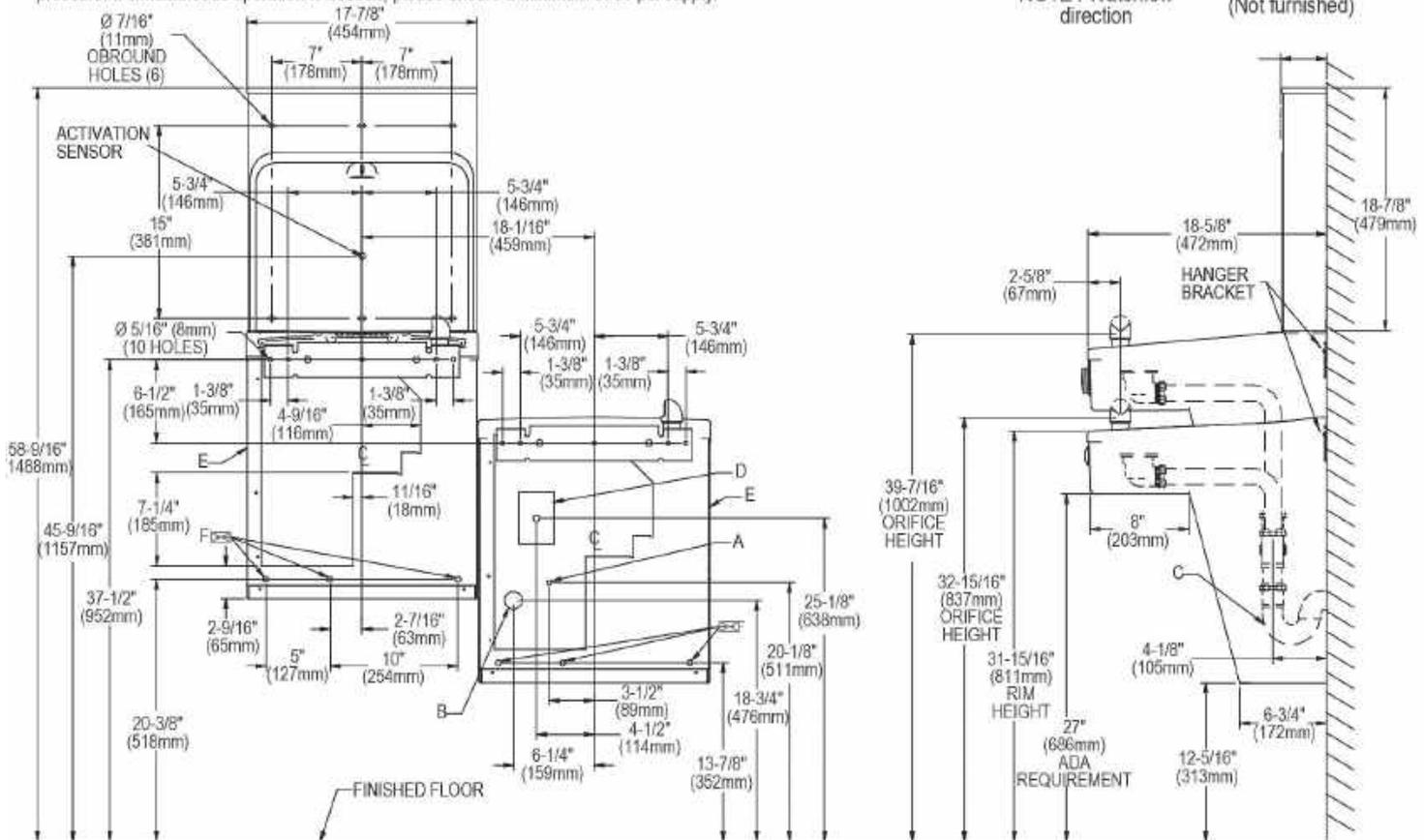
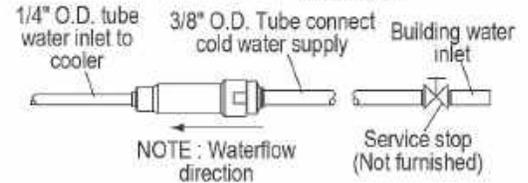

REDUCE HEIGHT BY 3 INCHES FOR INSTALLATION OF CHILDRENS ADA COOLER

### LEGEND:

- A = Recommended Water Supply location. Shut-off Valve (not furnished) to accept 3/8" O.D. unplated copper tube. Up to 3" (76mm) maximum out from wall.
- B = Recommended Waste Outlet location. To accommodate 1-1/2" nominal drain. Drain stub 2" (51mm) out from wall.
- C = 1-1/2" Trap (not furnished).
- D = Electrical Supply (3) Wire Recessed Box Duplex Outlet.
- E = Insure proper ventilation by maintaining 6" (152mm) minimum clearance from cabinet louvers to wall.
- F = 7/16" (11mm) Bolt Holes for fastening to wall.

Note: New Installations Must Use Ground Fault Circuit Interrupter (GFCI). It is highly recommended that the circuit be dedicated and the load protection be sized for 20 amps.

In keeping with our policy of continuing product improvement, Elkay reserves the right to change product specifications without notice. Please visit [elkay.com](http://elkay.com) for the most current version of Elkay product specification sheets. This specification describes an Elkay product with design, quality, and functional benefits to the user. When making a comparison of other producers' offerings, be certain these features are not overlooked.