



REQUEST FOR BID
ANNUAL CONTRACT FOR FENCE INSTALLATIONS
AND REPAIRS

Bid Number 2019-SW-15

July 2019

Bid Opening: Tuesday, September 3, 2019 at 3:00 p.m. (local time)
1600 Battle Creek Road, Morrow, Georgia 30260

Non-Mandatory Tuesday, August 20, 2019 at 3:00 p.m. (local time)
Pre-Bid Meeting 1600 Battle Creek Road, Morrow, Georgia 30260

This bid has a SLBE BID DISCOUNT

Table of Contents

Division 1	General Information	
Section 1	Request for Bids	1-1.1
Section 2	Project Overview	1-2.1
	2.1 Intent and Purpose	1-2.1
	2.2 Bid Evaluation	1-2.1
	2.3 Addendum	1-2.2
Division 2	Bid Requirements	
Section 1	Instructions to Bidders	2-1.1
Section 2	Risk Management Requirements	2-2.1
Section 3	Bid Submittals	2-3.1
Section 4	Bid Form	2-4.1
Section 5	Georgia Bid Bond (Not Required)	
Section 6	Bidder Qualification Information	2-6.1
Section 7	Contractor Affidavit & Agreement	2-7.1
Section 8	Small Local Business Enterprises General Information.....	2-8.1
Division 3	Contract Forms	
Section 1	Agreement Form.....	3-1.1
Section 2	Performance Bond (Not Required)	
Section 3	Payment Bond (Not Required)	
Section 4	Non-Collusion Certificate	3-4.1
Division 4	Specifications	
Section 1	Post Award Submittals	4-1.1
	1.1 General.....	4-1.1
	1.2 Submittal Requirements	4-1.1
Section 2	Work Assignment and Detail	4-2.1
	2.1 General.....	4-2.1
	2.2 Work Assignment and Detail	4-2.1
	2.3 Work Items and Measurement	4-2.2
Section 3	General Requirements	4-3.1
	3.1 General.....	4-3.1
	3.2 Site Work.....	4-3.1
	3.3 Material Specifications	4-3.2
	3.4 Acceptance.....	4-3.5

Table of Contents

Attachments

Waiver and Release Upon Final Payment

Details

Field Fence – Barbed Wire

Chain Link Fence – 4' and 5'

Chain Link Fence – 6' and 8'

Chain Link Fence – 6' and 8' with Barbed Wire

Wood Privacy Fence – Stockade

Wood Privacy Fence – Stockade Curved Top

Wood Privacy Fence – Shadow Box

Addendum(s) (None Issued at This Time)

END OF TABLE OF CONTENTS

Division 1

General Information

Section 1: Request for Bids

Clayton County Water Authority
1600 Battle Creek Road
Morrow, Georgia 30260

Name of Project: **Annual Contract for Fence Installations and Repairs.**

The Clayton County Water Authority will open sealed bids from qualified firms at its office located at 1600 Battle Creek Road, Morrow, Georgia 30260, on **Tuesday, September 10, 2019 at 3:00 p.m. (local time)** for Fence Installations and Repairs.

Any bids received after the specified time will not be considered.

A Non-Mandatory pre-bid meeting will be held on **Tuesday, August 20, at 3:00 p.m. (local time)** at 1600 Battle Creek Road, Morrow, Georgia, 30260.

CCWA encourages Small Local, Minority and Women-Owned businesses to participate and respond to this bid request.

In an effort to promote responsible environmental practices the bid package is available in electronic (Adobe PDF) format and can be requested by e-mail to **CCWA_Procurement@ccwa.us** or by calling **770-960-5223**, M-F, 8:00 am - 5:00 pm. Bidders will need to provide contact information and an email address and any file size transfer limits to insure email transmittals can be made. A hardcopy bid package can also be requested at a cost of \$25.

Clayton County Water Authority
By: John Chafin, Chairperson

END OF SECTION

Division 1

General Information

Section 2: Project Overview

2.1 Intent and Purpose

The Clayton County Water Authority (CCWA) intends to contract for the annual services of an experienced Contractor(s) to complete fence installations and repairs for the period **December 1, 2019 to November 30, 2020**. CCWA anticipates that the annual value of work to be completed through this contract will be in the range of \$60,000 to \$80,000.

The CCWA intends to award a Primary contract, as well as a Back-Up contract to ensure that CCWA's requests under this annual contract can be performed as needed. A Primary contract will be awarded to the lowest responsive responsible bidder whose bid conforms to the Request for Bids specifications and will be the most advantageous to the CCWA. A Back-Up contract may be awarded to the second lowest responsive responsible bidder whose bid conforms to the Request for Bids specifications and will be the most advantageous to the CCWA. Additionally, CCWA reserves the right to negotiate parity for any and all costs.

Work assignments under this contract will be initially offered to the Primary Contractor. Should productivity and/or quality of work of the Primary Contractor not meet contract specifications and/or CCWA's expectations, then work will be offered to the Back-Up Contractor.

The work to be performed under this contract will be determined and assigned by CCWA on an "as-needed", "when-needed" basis. CCWA does not guarantee any minimum or maximum work quantities under this contract and reserves the right to bid any similar type work of this contract as a separate procurement at its sole discretion.

The initial term of this contract will be for twelve (12) months. The contract may be extended for a second and third 12-month period by mutual written consent by both parties with no changes in the terms and conditions.

2.2 Bid Evaluation

To be considered responsive to this bid, bidders are required to bid on all work items listed in the Bid Form – Pay Item Schedule.

The total bid amount per bidder will be determined by taking the "unit cost" for each "work item" as shown on the "Bid Form - Pay Item Schedule" times an

Division 1

General Information

Section 2: Project Overview

estimated annual quantity for each “work item”. At the time of Bid Opening, CCWA will provide a list, to each bidder, of the “selected” work items and “estimated annual quantities” that CCWA has selected to use in determining the “total bid amount”.

Note that not all “work items” as shown on the Bid Form - Pay Item Schedule will be used in the bid evaluation process. Work items on the Bid Form – Pay Item Schedule not used in the award evaluation process will be examined by the CCWA to insure that the unit price is in line with comparable items contained in this bid and that any unit price that appear to be out of line may be used by the CCWA as a basis of denial/award of the particular bid and/or the unit price may be negotiated by CCWA. This determination will be at the sole discretion of CCWA.

This procurement has a Small Local Business Enterprise (SLBE) bid discount for evaluation purposes only, which will be given to CCWA certified SLBE primes only (regardless of their location). For more details, please refer to Division 2, Section 8 of this bid package.

2.3 Addendum

Bidders may submit questions regarding this bid prior to the bid opening. To be considered, all questions must be received by email at CCWA_Procurement@ccwa.us **by 3:00 pm EST, Thursday, August 22, 2019**. Any and all responses to bidder’s questions will be issued in the form of an Addendum by email. All addenda issued shall become part of the Bid Documents.

END OF SECTION

Division 2

Bid Requirements

Section 1: Instructions to Bidders

These instructions are to be followed by every entity bidding to provide the Clayton County Water Authority (CCWA) with goods and/or services. These instructions constitute an integral part of the Bid, and any Bidder agrees that tender of a Bid constitutes acknowledgment and acceptance of its obligation to adhere to these instructions, which are to be incorporated into and considered part of any contract the Bidder ultimately executes with the CCWA.

1. If there is any question whatsoever regarding any portion of the specifications, it shall be the Bidder's responsibility to seek clarification immediately from the CCWA, as early as possible prior to the bid opening. Regarding public works projects, requests for interpretations of specifications must be made in writing to the department proposing out the project not later than five (5) days prior to receipt of bids.
2. Unless it is otherwise stated in the bid documents, it shall be the responsibility of the bidder to inform itself as to all conditions of the work site and to make and take account thereof in calculating and submitting its bid. Documents may be made available by the CCWA during the bidding process; no warranty of accuracy is made in regard to these documents, and it is the responsibility of the bidder to make its own investigations as to the nature of the work and the conditions under which it shall be performed, and to make its own independent assumptions as to these matters. The burden of anticipating unforeseen circumstances, either hidden or latent, and the conditions of the work site and all related circumstances, and the cost of accommodating therefore should unanticipated circumstances be later encountered shall rest upon the bidder.
3. Pre-bid meeting or any other information session will be held at the location as indicated in the solicitation. Unless indicated otherwise, attendance is not mandatory; although vendors are strongly encouraged to attend. However, in the event the meeting is mandatory, then a representative of the vendor must attend the meeting in its entirety to be considered eligible for solicitation award. Late entry to the meeting will not be allowed.
4. In the event that, after the acceptance of a bid by the Board of Directors of the CCWA, any unsuccessful bidder wishes to contest such action, a written "Notice of Contest" must be filed with the General Manager no later than close of business on the 5th business day after the selection of successful bidder by the Board. Failure to timely file such notice shall forever preclude the filing of a contest of the award, or any civil action in the courts of the State of Georgia or of the United States.
5. Information submitted by the Bidder in the bid process shall be subject to disclosure after bid award in accordance with the Georgia Open Records Act. Proprietary

Division 2

Bid Requirements

Section 1: Instructions to Bidders

information must be identified and be accompanied by a signed affidavit outlining the redacted information. Entire bids may not be deemed proprietary.

6. Bids must be made on the enclosed Bid Form. Unless otherwise requested, one (1) original and at least two (2) copies of the Bid Form need to be submitted, and these copies must be **typewritten or printed in ink**. All copies of any Bid Forms must be signed in ink by the person or persons authorized to sign the Bid Form. The person signing the Bid Form must initial any changes or corrections.
7. The name of the person, firm, or corporation making the Bid must be printed in ink, along with the Bidder's signature, on all separate sheets of the Bid Form. If a Bid is made by an individual, his name and post office address must be shown. If made by a firm, or partnership, the name and the post office address of each member of the firm or partnership must be shown. If made by a Corporation, the person or persons signing the Bid must show the name of the State under the laws of which the Corporation is chartered and his, or their authority for signing same. The names, titles and addresses of the President, Secretary and the Treasurer and the corporate authority for doing business in this state shall be listed and returned with the Bid Form.
8. All Bids must be hand delivered, delivered by courier service, or mailed via the United States Postal Service. No facsimiles will be accepted. The person, firm, or corporation making the Bid shall submit it in a sealed envelope on or before the date and time specified in the Bid package. The envelope shall be marked "**Sealed Bid**" and carry the Bid title, and date and time of opening as set forth in the Bid package. The envelope shall also bear the name of the party making the Bid and the party's address. Address Bids to *Clayton County Water Authority, 1600 Battle Creek Road, Morrow, Georgia, 30260*. Even if a Bid is not submitted, the Bid Form should be returned signed and with an explanation, otherwise the result will be deletion from the mailing list.
9. If published price books are a part of your Bid, one price book must be included with your Bid Form, and the successful Bidder is required to furnish additional current price books after award of the Bid.
10. Alterations to the documents are strictly prohibited and shall result in automatic disqualification of the Bidder's bid. If there are "exceptions" to the specifications or comments to any of the solicitation requirements or other language, then the bidder may ask questions regarding those requirements or submit additional documentation as to the variation from the specifications, but may not alter any of the language contained in the solicitation.

Division 2

Bid Requirements

Section 1: Instructions to Bidders

11. In the case of goods, the person, firm or corporation making the Bid may Bid all items. All items may be considered separately, at the discretion of the CCWA.
12. Bids for public works whose price exceeds \$100,000.00 must be accompanied by a certified check, cashier's check, or acceptable bid bond in an amount not less than five percent (5%) of the amount bid.
13. Bidders for construction contracts where the laws of Georgia or the United States of America require a license in order to perform such construction must list the license number and class on the face of the bid envelope and must enclose copies of any required license with the bid.
14. When public work is let out for bid, no person shall prevent or attempt to prevent competition in such bid. Such bidders must make an oath filed with the officer who makes payments under the contract that they have not prevented or attempted to prevent competition in the bid process. Such oath must be signed by: if a partnership, all partners and any officer or agent or other person who acted on the partnership's behalf during the bid process; if a corporation, all officers, agents, or other persons who acted for the corporation in the bid process.
15. Bids shall not be withdrawn or cancelled by the bidder past the bid opening date and time. The bidder may make modifications/corrections to the bid by submitting a corrected seal bid but only if the change is prior to the bid opening. The corrected document should be clearly marked that it supersedes the bid originally submitted. No modification or corrections will be allowed subsequent to the bid opening.
16. By tendering a bid, a Bidder agrees to leave the bid open for acceptance by the CCWA for ninety (90) days after the date set for the opening thereof.
17. By tendering a bid, the bidder certifies that the bidder has carefully examined these instructions and the terms and specifications applicable to and made a part of the bid. The Bidder further certifies that the prices shown in any schedule of items on which the Bidder is proposing are in accordance with the conditions, terms and specifications of the bid and that they are aware that any exception taken thereto may disqualify the bid. Bidders are required to inform themselves fully as to the availability of materials and the conditions relating to construction and labor under which any work will be or is now being performed. No error or misjudgment nor any lack of information on local conditions, general laws or regulations on the part of the Bidder shall merit withdrawal of the bid.

Division 2

Bid Requirements

Section 1: Instructions to Bidders

18. Copies of all communication pertaining to bids must be sent to the Contracts, Compliance and Risk Management Section.
19. The purpose of this bid is to establish contract prices. Unit price extension and net total must be shown if applicable. Cash discounts should be indicated separately. The CCWA is exempt from federal or state sales taxes; do not include such amounts in the bid. Exemption certificates are furnished upon request.
20. Bidders are hereby notified and agree by submission of a Bid Form that if additional items not listed in the Bid Form become necessary and require unit prices not established by the Bid Form, the unit prices of such items shall be negotiated and shall be directly proportional to the established unit prices of similar items in the Bid Form.
21. All prices on goods shall be for delivery, our destination, f.o.b. freight prepaid Jonesboro, Georgia, and/or Morrow, Georgia, unless otherwise shown. Any deliveries shall be made as needed and requested throughout the contract period.
22. Quantities when shown are estimates only, based on anticipated needs. The CCWA reserves the right to purchase more or less based on actual need at contract price. If a Bidder intends to offer minimum or maximum shipment quantities, such intent and such quantities should be specified on the Bid Form. Otherwise, none will be assumed.
23. The time for completion of the work is stated in the Bid Form. Failure to complete the work within this period shall result in payment to the CCWA of liquidated damages in an amount provided for by contract for each calendar day in excess of the Contract time.
24. The Bidder must employ such methods and means in carrying out the work as will not cause any interruption of or interference with any other Contractor.
25. The successful Bidder must comply with the applicable Risk Management Requirements prior to beginning performance, and during the contract period.
26. The Contract between the CCWA and the Contractor shall be executed on a form provided by CCWA and will be subject to all requirements of the contract documents (which include but may not be limited to the Contract, these instructions, any Purchase Orders, and the Risk Management Requirements), and shall form a binding contract between the contracting parties.
27. Failure to execute the Contract, any required Surety Performance and Payment Bonds, or to furnish any required satisfactory proof of carriage of required insurance within ten (10) days from the date of notice of award of the Contract shall be just cause for the

Division 2

Bid Requirements

Section 1: Instructions to Bidders

annulment of the award and for forfeiture of the bid guaranty to the CCWA, not as a penalty, but in liquidation of damages sustained. At the discretion of the CCWA, the award may then be made to the next lowest responsible vendor, or the work may be re-advertised or constructed by the CCWA.

28. Any Contract and Contract Bonds shall be executed in duplicate.
29. Award of this bid shall be by action of the CCWA Board at its regular monthly meeting.
30. The CCWA reserves the right, with or without notice or cause, to accept any bid regardless of the amount thereof; to reject any bid, or any number of bids; to negotiate with any Bidder for a reduction of or alterations in its bid; to reject all bids and to call for additional bids upon the same or different invitations to bid, plans or specifications; to be sole judge, in its discretion, on all questions as to whether or not a bid complies with the invitation to Bid, the plans or the specifications, and as to the solvency and sufficiency of any and all sureties on all bonds.
31. The apparent low bid for goods shall be considered to be the lowest aggregate total price of specified products at their unit prices times the estimated required quantities of these specified products.
32. Bids received from two (2) or more vendors that are identical in price, delivery and meet the requirements of the bid specifications shall be awarded on the following basis:
 - a. The bid submitted by a vendor who does not have a documented negative vendor performance record.
 - b. The bid submitted by a vendor who is located within Clayton County.
 - c. The bid submitted by a vendor who is certified by our Small Local Business Enterprise Program.
 - d. If the tie bids meet all the above criteria, and it is not in the Authority's best interest (at its sole discretion) to split the award, the bid award is based on the toss of a coin by CCWA staff in a public session. The vendors involved will be invited to attend the coin toss at a stated date and time. One or more witnesses from both CCWA Procurement and the Requesting Department may be present. A simple coin toss (called by the vendor listed first in the alphabet) will break the tie and decide the award.
33. While price is the prime criteria, and the CCWA intends to purchase at the lowest responsible bid available, price shall not be the sole criteria utilized by the CCWA in

Division 2

Bid Requirements

Section 1: Instructions to Bidders

evaluating the bid package submitted. The following criteria shall also be utilized by the CCWA in determining the lowest responsible bid:

- a. Ability of Bidder to perform in the time frame needed by the CCWA.
 - b. Reputation of the Bidder in its industry.
 - c. Reasonableness of the bid in relation to anticipated costs.
 - d. Ongoing relationships with the CCWA based on above-average prior performance of work with the Authority.
34. Bidders are notified that the Authority reserves the right except in the case of public works contracts to include among the factors considered in awarding the contract the proximity of each Bidder's place of business to any affected Authority facility. The Authority further reserves the right to award the contract to a Bidder other than the Bidder offering the lowest price where: (a) the difference in price between the low Bidder and the preferred Bidder is nominal; and (b) the Authority's Board determines that the preferred bid provides the most cost effective option due to the closer proximity of the preferred Bidder's place of business to the affected Authority facility or facilities. In such a situation, by responding to this bid, the Bidder waives any cause of action against the Authority for frustration of bid or under any similar legal theory; furthermore, the Bidder agrees to pay all costs and expenses, including but not limited to attorney fees, incurred by the Authority in defending against any such claim.
35. It is the policy of the Clayton County Water Authority (CCWA) to promote award of sub-agreements for goods and/or services to qualified small local, minority and women-owned businesses. Bidders are encouraged to solicit small local, minority and women-owned businesses whenever they are potential sources.
36. Bidders are encouraged to utilize the services and assistance of the U.S. Small Business Administration (SBA), and the office of the Department of Commerce Minority Business Development Agency (MBDA). These agencies can provide assistance in securing the names of qualified minority and women-owned businesses. Additionally, it is encouraged that bidders access certified Small Local Business Enterprise (SLBE) vendors from Clayton County, DeKalb County, and City of Atlanta.

The Georgia Department of Transportation (DOT) has established a list of qualified Disadvantaged Business Enterprises. Information is available online under the tab for "Directories", link for "UCP Directory - Excel" at:

<http://www.dot.ga.gov/PS/Business/DBE>.

Division 2

Bid Requirements

Section 1: Instructions to Bidders

The successful Bidder will be asked to provide, along with his Request for Payment each month a list of qualified SLBE and MBE/WBE businesses utilized on this Project.

GEORGIA SECURITY AND IMMIGRATION COMPLIANCE ACT OF 2006

37. Pursuant to the Georgia Security and Immigration Compliance Act of 2006, the successful Contractor understands and agrees that compliance with the requirements of O.C.G.A. 13-10-91 and Georgia Department of Labor Rule 300-10-02 are conditions of this bid and contract document. The Contractor further agrees that such compliance shall be attested by the Contractor and any of his Subcontractors by execution of the appropriate Affidavit and Agreement included after the Agreement Form of these documents.

END OF SECTION

Division 2

Bid Requirements

Section 2: Risk Management Requirements

The Contractor will provide minimum insurance coverage and limits as per the following: The Contractor will file with the Authority Certificates of Insurance, certifying the required insurance coverages and stating that each policy has been endorsed to provide thirty (30) day notice to the Authority in the event that coverage is cancelled, non-renewed or the types of coverage or limits of liability are reduced below those required. All bonds and insurance coverage must be placed with an insurance company approved by Authority Management, admitted to do business in the State of Georgia, and rated Secure (“B+” or better) by A.M. Best Company in the latest edition of Property and Casualty Ratings, or rated by Standard & Poors Insurance Ratings, latest edition as Secure (“BBB” or better). Worker’s Compensation self-insurance for individual Contractors must be approved by the Worker’s Compensation Board, State of Georgia and/or Self-Insurance pools approved by the Insurance Commissioner, State of Georgia.

CONTRACTS FOR UP TO \$50,000

Worker’s Compensation – Worker’s Compensation coverage on a statutory basis for the State of Georgia with an Employer’s Liability limit of \$100,000 each Accident, Disease \$100,000 each employee, \$500,000 Disease policy limit.

Automobile Liability – Automobile liability coverage for owned, hired and non-owned vehicles in the amount of \$500,000 combined single limit.

Commercial General Liability – Coverage to be provided on “occurrence” not “claims made” basis. The coverage is to include Contractual liability, Per Project Limit of Liability, losses caused by Explosion, Collapse and Underground (“xcu”) perils, the “Clayton County Water Authority” is to be added as an Additional Insured and Products and Completed Operations coverage is to be maintained for three (3) years following completion of work.

CONTRACTS FOR MORE THAN \$50,000

Worker’s Compensation – Worker’s Compensation coverage on a statutory basis for the State of Georgia with an Employer’s Liability limit of \$1,000,000. The increased Employer’s Liability limit may be provided by an Umbrella or Excess Liability policy.

Automobile Liability - Automobile liability coverage for owned, hired and non-owned vehicles in the amount of \$1,000,000 combined single limit.

Commercial General Liability – Coverage to be provided on “occurrence” not “claims made” basis. The coverage is to include Contractual liability, Per Project Limit of Liability, losses caused by Explosion, Collapse and Underground (“xcu”) perils, the “Clayton County Water Authority” is to be added as an Additional Insured and Products and Completed Operations coverage is to be maintained for three (3) years following completion of work.

Division 2

Bid Requirements

Section 2: Risk Management Requirements

CONTRACTS FOR UP TO \$50,000

CONTRACTS FOR MORE THAN \$50,000

LIMITS OF LIABILITY:

\$1,000,000	Per Occurrence
\$1,000,000	Personal and Advertising
\$50,000	Fire Damage*
\$5,000	Medical Payments*
\$1,000,000	General Aggregate
\$1,000,000	Products/Completed Operations per Occurrence and Aggregate

**These are automatic minimums*

Owner's Protective Liability – The Authority's Management may, in its discretion, require Owner's Protective Liability in some situations.

Umbrella and/or Excess Liability – The umbrella or Excess Liability Policy may be used to combine with underlying policies to obtain the limits required. The Management of the Authority may elect to require higher limits.

Owner's Protective Liability – The Authority's Management may, in its discretion, require Owner's Protective Liability in some situations.

END OF SECTION

Division 2

Bid Requirements

Section 3: Bid Submittals

3.1 Required Bid Submittals:

The following items are required to be included as part of the bid submittal. Failure to include any of these items may result in the bid being deemed non-responsive:

- A. Bid Form, Division 2, Section 4.
- B. Bidder Qualification Information, including References. Failure to provide satisfactory references will result in the bid being deemed non-responsive.
- C. Georgia Security and Immigration Compliance Act of 2006 form.
- D. Contractor Affidavit and Agreement form.
- E. Subcontractor Affidavit form.

If a Contractor/Subcontractor will not be performing any services under this contract, the Contractor/company submitting the bid MUST also complete, sign, date, and have both Affidavit forms notarized and make proper notation of "N/A" - Not Applicable.

CCWA cannot consider any bid which does not include completed affidavits. It is not the intent of this notice to provide detailed information or legal advice concerning the Georgia Security & Immigration Compliance Act of 2006, as amended on May 11, 2009. All Bidders intending to do business with CCWA are responsible for independently apprising themselves and complying with the requirements of that law and its effect on CCWA procurements and their participation in those procurements.

- F. SLBE Forms – Bidders must submit their proof of SLBE Certification with CCWA if applicable
- G. Addenda (if any issued).

END OF SECTION

Division 2

Bid Requirements

Section 4: Bid Form

Bid of _____

(Hereinafter "Bidder"), organized and existing under the laws of the State of _____,

doing business as _____ (insert "a corporation," "a partnership," or "an individual" or such other business entity designation as is applicable).

To the Clayton County Water Authority (hereinafter "Owner").

In compliance with the Request for Bids, Bidder hereby proposes to perform all Work for **Annual Contract for Fence Installations and Repairs** in strict accordance with the Contract Documents as enumerated in the Request for Bids, within the time set forth therein, and at the prices stated below.

By submission of this bid, Bidder certifies, and in the case of joint bid each party thereto certifies as to the party's own organization that this bid has been arrived at independently, without consultation, communication, or agreement as to any matter relating to this bid with any other Bidder or with any competitor. Bidder also certifies compliance with the Instructions to Bidders.

In submitting this bid, Bidder certifies Bidder is qualified to do business in the state of Georgia as required by laws, rules, and regulations or, if allowed by statute, covenants to obtain such qualification prior to contract award.

CONTRACT EXECUTION:

The undersigned Bidder agrees, if this bid is accepted, to enter into an Agreement with OWNER on the form included in the Documents to perform and furnish Work as specified or indicated in the Documents for the Contract Price derived from the bid and within the times indicated herein and in accordance with the other terms and conditions of the Documents.

Bidder accepts the terms and conditions of the Documents.

INSURANCE:

Bidder further agrees that bid amount(s) stated herein includes specific consideration for the specified insurance coverages.

Division 2

Bid Requirements

Section 4: Bid Form

BID:

The undersigned proposes to complete, in all respects, sound, complete and conformable with this Contract Document the following work for the following amounts.

CCWA guarantees no minimum or maximum quantities, and additionally reserves the right to purchase more or less at the unit price, based on actual need.

ADDENDA:

Bidder acknowledges receipt of the following Addenda:

Division 2

Bid Requirements

Section 4: Bid Form – Pay Item Schedule

No.	Work Item	Detail	Unit	Unit Cost
1	Emergency Mobilization	N/A	EA	
2	Field Fence Posts	Install Corner / Brace Post	EA	
3		Install Horizontal Brace	EA	
4		Install Line Post - Wood	EA	
5		Install Line Post - Steel	EA	
6	Field Fence 3-Strand Barbed Wire	Install Fencing up to 12 feet	EA	
7		Install Fencing greater than 12 feet	LF	
8		Remove Existing Fencing	LF	
9	Field Fence 4-Strand Barbed Wire	Install Fencing up to 12 feet	EA	
10		Install Fencing greater than 12 feet	LF	
11		Remove Existing Fencing	LF	
12	Field Fence 5-Strand Barbed Wire	Install Fencing up to 12 feet	EA	
13		Install Fencing greater than 12 feet	LF	
14		Remove Existing Fencing	LF	
15	Chain-Link Fence 4-Foot Galvanized	Install Fencing up to 10 feet	EA	
16		Install Fencing greater than 10 feet	LF	
17		Install Corner / Pull Post	EA	
18		Install Walk Gate (3'-6" Wide)	EA	
19		Install Walk Gate (4' Wide)	EA	
20		Install Drive Gate (10' Wide)	EA	
21		Install Drive Gate (12' Wide)	EA	
22		Remove Existing Fencing	LF	
23	Chain-Link Fence 4-Foot Vinyl Coated	Install Fencing up to 10 feet	EA	
24		Install Fencing greater than 10 feet	LF	
25		Install Corner / Pull Post	EA	
26		Install Walk Gate (3'-6" Wide)	EA	
27		Install Walk Gate (4' Wide)	EA	
28		Install Drive Gate (10' Wide)	EA	
29		Install Drive Gate (12' Wide)	EA	
30		Remove Existing Fencing	LF	

Division 2

Bid Requirements

Section 4: Bid Form – Pay Item Schedule

No.	Work Item	Detail	Unit	Unit Cost
31	Chain-Link Fence 5-Foot Galvanized	Install Fencing up to 10 feet	EA	
32		Install Fencing greater than 10 feet	LF	
33		Install Corner / Pull Post	EA	
34		Install Walk Gate (3'-6" Wide)	EA	
35		Install Walk Gate (4' Wide)	EA	
36		Install Drive Gate (10' Wide)	EA	
37		Install Drive Gate (12' Wide)	EA	
38		Remove Existing Fencing	LF	
39	Chain-Link Fence 5-Foot Vinyl Coated	Install Fencing up to 10 feet	EA	
40		Install Fencing greater than 10 feet	LF	
41		Install Corner / Pull Post	EA	
42		Install Walk Gate (3'-6" Wide)	EA	
43		Install Walk Gate (4' Wide)	EA	
44		Install Drive Gate (10' Wide)	EA	
45		Install Drive Gate (12' Wide)	EA	
46		Remove Existing Fencing	LF	
47	Chain-Link Fence 6-Foot Galvanized	Install Fencing up to 10 feet	EA	
48		Install Fencing greater than 10 feet	LF	
49		Install Corner / Pull Post	EA	
50		Install Horizontal Brace	EA	
51		Install Walk Gate (4' Wide)	EA	
52		Install Drive Gate (12' Wide)	EA	
53		Install Drive Gate (16' Wide)	EA	
54		Remove Existing Fencing	LF	
55	Chain-Link Fence 6-Foot Galvanized with 3- Strands Barbed Wire	Install Fencing up to 10 feet	EA	
56		Install Fencing greater than 10 feet	LF	
57		Install Corner / Pull Post	EA	
58		Install Horizontal Brace	EA	
59		Install Walk Gate (4' Wide)	EA	
60		Install Drive Gate (12' Wide)	EA	
61		Install Drive Gate (16' Wide)	EA	
62		Remove Existing Fencing	LF	

Division 2

Bid Requirements

Section 4: Bid Form – Pay Item Schedule

No.	Work Item	Detail	Unit	Unit Cost
63	Chain-Link Fence 6-Foot Vinyl Coated	Install Fencing up to 10 feet	EA	
64		Install Fencing greater than 10 feet	LF	
65		Install Corner / Pull Post	EA	
66		Install Horizontal Brace	EA	
67		Install Walk Gate (4' Wide)	EA	
68		Install Drive Gate (12' Wide)	EA	
69		Install Drive Gate (16' Wide)	EA	
70		Remove Existing Fencing	LF	
71		Chain-Link Fence 6-Foot Vinyl Coated with 3- Strands Barbed Wire	Install Fencing up to 10 feet	EA
72	Install Fencing greater than 10 feet		LF	
73	Install Corner / Pull Post		EA	
74	Install Horizontal Brace		EA	
75	Install Walk Gate (4' Wide)		EA	
76	Install Drive Gate (12' Wide)		EA	
77	Install Drive Gate (16' Wide)		EA	
78	Remove Existing Fencing		LF	
79	Chain-Link Fence 8-Foot Galvanized		Install Fencing up to 10 feet	EA
80		Install Fencing greater than 10 feet	LF	
81		Install Corner / Pull Post	EA	
82		Install Horizontal Brace	EA	
83		Install Walk Gate (4' Wide)	EA	
84		Install Drive Gate (12' Wide)	EA	
85		Install Drive Gate (16' Wide)	EA	
86		Remove Existing Fencing	LF	
87		Chain-Link Fence 8-Foot Galvanized with 3- Strands Barbed Wire	Install Fencing up to 10 feet	EA
88	Install Fencing greater than 10 feet		LF	
89	Install Corner / Pull Post		EA	
90	Install Horizontal Brace		EA	
91	Install Walk Gate (4' Wide)		EA	
92	Install Drive Gate (12' Wide)		EA	
93	Install Drive Gate (16' Wide)		EA	
94	Remove Existing Fencing		LF	

Division 2

Bid Requirements

Section 4: Bid Form – Pay Item Schedule

No.	Work Item	Detail	Unit	Unit Cost
95	Chain-Link Fence 8-Foot Vinyl Coated	Install Fencing up to 10 feet	EA	
96		Install Fencing greater than 10 feet	LF	
97		Install Corner / Pull Post	EA	
98		Install Horizontal Brace	EA	
99		Install Walk Gate (4' Wide)	EA	
100		Install Drive Gate (12' Wide)	EA	
101		Install Drive Gate (16' Wide)	EA	
102		Remove Existing Fencing	LF	
103	Chain-Link Fence 8-Foot Vinyl Coated with 3- Strands Barbed Wire	Install Fencing up to 10 feet	EA	
104		Install Fencing greater than 10 feet	LF	
105		Install Corner / Pull Post	EA	
106		Install Horizontal Brace	EA	
107		Install Walk Gate (4' Wide)	EA	
108		Install Drive Gate (12' Wide)	EA	
109		Install Drive Gate (16' Wide)	EA	
110		Remove Existing Fencing	LF	
111	Chain-Link Fence (Temporary) Up to 6-Foot Galvanized	Install and Remove Fencing up to 50 feet	EA	
112		Install and Remove Fencing greater than 50 feet	LF	
113		Install Walk Gate (4' Wide)	EA	
114	Wood Privacy Fence 6-Foot Stockade / Dog-Eared	Install Fencing up to 8 feet	EA	
115		Install Fencing greater than 8 feet	LF	
116		Install Post	EA	
117		Install Walk Gate (4' Wide)	EA	
118		Install Drive Gate (10' Wide)	EA	
119		Remove Existing Fencing	LF	
120	Wood Privacy Fence 6-Foot Curved Top	Install Fencing up to 8 feet	EA	
121		Install Fencing greater than 8 feet	LF	
122		Install Post	EA	
123		Install Walk Gate	EA	
124		Remove Existing Fencing	LF	

Division 2

Bid Requirements

Section 4: Bid Form – Pay Item Schedule

No.	Work Item	Detail	Unit	Unit Cost
125	Wood Privacy Fence 6-Foot Shadow Box	Install Fencing up to 8 feet	EA	
126		Install Fencing greater than 8 feet	LF	
127		Install Post	EA	
128		Install Walk Gate	EA	
129		Remove Existing Fencing	LF	
130	Hourly Labor	1 Man Crew	HR	
131		2 Man Crew	HR	
132		3 Man Crew	HR	
133	Special Material	N/A	EA	10%

Submitted by:

(NAME OF BIDDER)

Division 2

Bid Requirements

Section 4: Bid Form

To be considered responsive to this bid, bidders are required to bid on all work items listed on the Bid Form - Pay Item Schedule.

Submitted by:

(NAME OF BIDDER)

By: _____
(SIGNATURE)

(TITLE)

(DATE)

_____ (SEAL)
(ATTEST)

(ADDRESS)

(PHONE NUMBER)

(LICENSE NUMBER) (If applicable)

(E-MAIL ADDRESS)

END OF SECTION

Division 2

Bid Requirements

Section 6: Bidder Qualification Information

COMPANY NAME OF BIDDER: _____

NUMBER OF YEARS IN BUSINESS _____

BUSINESS ADDRESS OF COMPANY: _____

TELEPHONE NUMBER: _____

POINT OF CONTACT NAME: _____

POINT OF CONTACT EMAIL ADDRESS: _____

COMPANY TAX ID NUMBER: _____

COMPANY WEBSITE: _____

- ENTITY TYPE: Individual/Sole Proprietor Employee Owned Company
 Privately Held Corporation/LLC Partnership
 Publicly Owned Company Attorney
 Other (specify): _____

NAME OF PRINCIPAL OFFICERS: _____

Division 2

Bid Requirements

Section 6: Bidder Qualification Information

REFERENCES

LIST AT LEAST 3 REFERENCES OF SIMILAR COMMERCIAL OR GOVERNMENT WORK COMPLETED IN THE PAST 5 YEARS:

COMPANY/GOV'T ENTITY NAME: _____

CONTACT NAME: _____

PHONE NUMBER: _____

ADDRESS: _____

COMPANY/GOV'T ENTITY NAME: _____

CONTACT NAME: _____

PHONE NUMBER: _____

ADDRESS: _____

COMPANY/GOV'T ENTITY NAME: _____

CONTACT NAME: _____

PHONE NUMBER: _____

ADDRESS: _____

END OF SECTION

Division 2

Bid Requirements

Section 7: Contractor Affidavit & Agreement

GEORGIA SECURITY AND IMMIGRATION COMPLIANCE ACT OF 2006

- A. Pursuant to the Georgia Security and Immigration Compliance Act of 2006, the Contractor understands and agrees that compliance with the requirements of O.C.G.A. § 13-10-91 and Georgia Department of Labor Rule 300-10-.02 are conditions of this Agreement. The Contractor further agrees that such compliance shall be attested by the Contractor through execution of the contractor affidavit required by Georgia Department of Labor Rule 300-10-1-.07, or a substantially similar contractor affidavit. The Contractor's fully executed affidavit is attached hereto as Exhibit ____ and is incorporated into this Agreement by reference herein.

- B. By initialing in the appropriate line below, the Contractor certifies that the following employee-number category as identified in O.C.G.A. § 13-10-91 is applicable to the Contractor:
 - 1. _____ 500 or more employees;
 - 2. _____ 100 or more employees;
 - 3. _____ Fewer than 100 employees.

- C. The Contractor understands and agrees that, in the event the Contractor employs or contracts with any subcontractor or subcontractors in connection with this Agreement, the Contractor shall:
 - 1. Secure from each such subcontractor an indication of the employee-number category as identified in O.C.G.A. § 13-10-91 that is applicable to the subcontractor;
 - 2. Secure from each such subcontractor an attestation of the subcontractor's compliance with O.C.G.A. § 13-10-91 and Georgia Department of Labor Rule 300-10-1-.02 by causing each such subcontractor to execute the subcontractor affidavit required by Georgia Department of Labor Rule 300-10-1-.08, or a substantially similar subcontractor affidavit. The Contractor further understands and agrees that the Contractor shall require the executed subcontractor affidavit to become a part of the agreement between the Contractor and each such subcontractor. The Contractor agrees to maintain records of each subcontractor attestation required hereunder for inspection by the Clayton County Water Authority at any time."

Contractor _____

Authorized Signature: _____

Name: _____

Title: _____

Date: _____

Division 2

Bid Requirements

Section 7: Contractor Affidavit & Agreement

CONTRACTOR AFFIDAVIT AND AGREEMENT

By executing this affidavit, the undersigned contractor verifies its compliance with [O.C.G.A. 13-10-91](#), stating affirmatively that the individual, firm, or corporation which is contracting with the Clayton County Water Authority has registered with, is participating in, uses, and will continue to use for the duration of the contract, the federal work authorization program - EEV/Basic Pilot Program operated by the U. S. Citizenship and Immigration Services Bureau of the U.S. Department of Homeland Security, in conjunction with the Social Security Administration (SSA), commonly known as E-Verify, in accordance with the applicability provisions established in [O.C.G.A. 13-10-91](#).

The undersigned further agrees that, in connection with the physical performance of services pursuant to this contract with the Clayton County Water Authority, the contractor will only employ or contract with subcontractor(s), who can present a similar affidavit verifying the subcontractor's compliance with [O.C.G.A. 13-10-91](#). Contractor further agrees to maintain records of such compliance and provide a copy of each such verification to the Clayton County Water Authority within five days of the subcontractor(s) presenting such affidavit(s) to the contractor.

EEV / Basic Pilot Program* User Identification Number
Enter four to seven-digit numbers

Name of Contractor (Printed)

BY: Authorized Officer or Agent
(Contractor Name)

Date

Title of Authorized Officer or Agent of Contractor

Printed Name of Authorized Officer or Agent

SUBSCRIBED AND SWORN BEFORE ME ON THIS

THE _____ DAY OF _____ 20____.

Notary Public

My Commission Expires

Division 2

Bid Requirements

Section 7: Contractor Affidavit & Agreement

SUBCONTRACTOR AFFIDAVIT AND AGREEMENT

By executing this affidavit, the undersigned subcontractor verifies its compliance with [O.C.G.A. 13-10-91](#), stating affirmatively that the individual, firm or corporation which is engaged in the physical performance of services under a contract with _____

_____ on behalf of the Clayton County Water Authority has registered with, is participating in, uses, and will continue to use for the duration of the contract the federal work authorization program - EEV/Basic Pilot Program operated by the U. S. Citizenship and Immigration Services Bureau of the U.S. Department of Homeland Security, in conjunction with the Social Security Administration (SSA), commonly known as E-Verify, in accordance with the applicability provisions and deadlines established in [O.C.G.A. 13-10-91](#).

The undersigned further agrees that, in connection with the physical performance of services pursuant to this contract with _____

_____ on behalf of the Clayton County Water Authority, the subcontractor will only employ or contract with sub-subcontractor(s), who can present a similar affidavit verifying the sub-subcontractor's compliance with [O.C.G.A. 13-10-91](#). The undersigned further agrees that the Subcontractor will maintain records of such compliance and provide a copy of each such verification to the Contractor within five days of the sub-subcontractor(s) presenting such affidavit(s) to the Sub-contractor.

EEV / Basic Pilot Program* User Identification Number
Enter four to seven-digit numbers

Name of Sub-Contractor (Printed)

BY: Authorized Officer or Agent
(Subcontractor Name)

Date

Title of Authorized Officer or Agent of Subcontractor

Printed Name of Authorized Officer or Agent

Subscribed and sworn before me on this the _____ day of _____ 20____.

Notary Public

My Commission Expires

Division 2

Bid Requirements

Section 8: Small Local Business Enterprise General Information

8.1 Program Overview

Clayton County Water Authority (CCWA) has implemented a Small Local Business Enterprise Program to promote full and open competition in all government procurement and purchasing. Bid discounts for the use of Small Local Business Enterprises (SLBE's) are set on a contract by contract basis for each specific prime contract with subcontracting possibilities. CCWA wants to ensure that Bidders are non-discriminatory in their process of selecting subcontractors. CCWA also wants to encourage Bidders to utilize small, minority or woman-owned businesses whenever possible. All forms included in this solicitation must be completed for Bidder to be considered responsive.

SLBE means a locally-based small business operating inside or outside of Clayton County, which meets the following criteria:

- A) Independently owned and operated business concern whose average annual gross receipts for the previous three years must not exceed (1) Construction Firms – \$18,250,000; (2) Professional Services Firms – \$5,500,000; Architectural Firms – \$3,750,000; Engineering Firms – \$7,500,000, and Goods and Services – less than 250 employees.
- B) Locally based, meaning located and operating in Clayton County or the ten (10) counties of Cherokee, Cobb, DeKalb, Douglas, Fayette, Fulton, Gwinnett, Henry, Rockdale and Spalding for at least one year prior to submitting application for certification.

If a firm is locally-based in one of the counties mentioned above and is currently certified as a small business through Clayton County, the City of Atlanta, DeKalb County, or the Georgia Department of Transportation, and can provide evidence of its certification, the firm will be provisionally accepted as a CCWA SLBE, provided that they complete the official certification application for CCWA. If a firm meets these qualifications, but is not currently certified as a CCWA small business, then the firm must complete an application for certification with CCWA no later than seven (7) business days following the deadline for bid submission.

SLBE's must perform a commercially useful function, which means performance of provision of real and actual services under the contract or subcontract with CCWA. Factors such as the nature and amount of the work subcontracted; whether the SLBE has the skill and expertise to perform the work for which it has been certified; whether the SLBE actually performs, manages or supervises the work; and whether the SLBE intends to purchase commodities and/or services

Division 2

Bid Requirements

Section 8: Small Local Business Enterprise General Information

from a non-SLBE and simply resell them will be considered in determining if the SLBE is performing a commercially useful function.

Participation in the SLBE program is not a requirement to participate in contracting with CCWA. The use of an SLBE is a requirement when bid discounts are to be sought. The Bidder will be required to complete the required forms as outlined in the following section.

8.2 Overview of Bid Discount

Bid discounts are incentives that allow an original bid amount to be discounted for evaluation purposes in determining the lowest responsive, responsible bidder, while the original bid amount will be the basis for contract award.

Example: A \$100,000 bid with a 7.5% bid discount would be evaluated at \$92,500. However, \$100,000 would be paid to the successful bidder.

Bid Discounts will be applied to CCWA certified SLBE prime bidders only. *The use of certified SLBE sub-contractors will not establish eligibility to receive Bid Discounts.* Depending on the bidder's location, Bid Discounts will range between 7.5% and 10%.

The calculation of SLBE bid discounts shall be as follows:

There will be an applied tiered discount to bids based on what county the SLBE business is located.

- 10 percent for SLBE's in Clayton County.
 - 7.5 percent for SLBE's within the next surrounding 10 counties (Cherokee, Cobb, DeKalb, Douglas, Fayette, Fulton, Gwinnett, Henry, Rockdale and Spalding).
- (1) Discounts are given to Bidders who are SLBE prime bidders only.
 - (2) In the event of a tie bid between a discounted bidder and a non-discounted bidder, the discounted bidder (SLBE) will be recommended for the contract.

By signing the bid, the bidder is certifying that he/she has complied with the requirements of this program. Please contact Contracts, Compliance and Risk Management at ccwa_slbe_program@ccwa.us for more information on CCWA's SLBE Program or visit our website at www.ccwa.us.

END OF SECTION

Division 3

Contract Forms

Section 1: Agreement Form

**STATE OF GEORGIA
COUNTY OF CLAYTON**

**AGREEMENT FOR ONGOING PROVISION
OF GOODS AND SERVICES**

This Agreement made and entered into this _____ day of _____, 2019, for **Annual Contract for Fence Installations and Repairs**, between the **CLAYTON COUNTY WATER AUTHORITY** (hereinafter "the Authority") and _____ (hereinafter "the Contractor"), witnesseth:

WHEREAS, the Authority is contracting with the Contractor for the provision of certain goods and services described below for the term specified herein;

NOW THEREFORE, the parties agree as follows:

1. **DESCRIPTION OF GOODS AND SERVICES**: The Contractor shall provide the goods and services to the Authority in such quantities as the Authority requires for **Annual Contract for Fence Installations and Repairs**, as described in the Request for Bid dated July 2019.
2. **COSTS**: The Authority shall pay the Contractor the prices as stipulated in the Bid Form hereto attached as full compensation relative to the Bid dated _____, 2019, and above described goods and services. The Authority will not guarantee any minimum or maximum quantities during the contract term. Work under this contract will be authorized on an "as needed – when needed basis", and will be paid per the bid unit prices as submitted and approved. Payment for work completed will be processed upon submission of an Invoice and Affidavit of Completion by the Contractor. The invoice will be verified by the Authority representative, and any changes/corrections to the invoice will require the contractor to correct and re-submit the invoice. The Authority will accept invoices on a once per week basis. The Authority shall pay the Contractor net 30 days upon receipt of the invoice, and upon acceptance of the work in accordance with the specifications. Payments will be made via regular US Mail.
3. **TERM OF AGREEMENT**: The term of this Agreement shall commence on the **1st day of December, 2019**. The Agreement shall remain in effect until **November 30, 2020**.

Division 3

Contract Forms

Section 1: Agreement Form

4. **RENEWAL PROVISIONS:** The contract may be extended for a second and third 12 month period by mutual written consent by both parties with no changes in terms, conditions, and bid prices.

5. **WARRANTY ON SERVICES RENDERED:** The Contractor warrants its workmanship to be free from defects for a period of two (2) years from the date of final acceptance. The Contractor further warrants that its workmanship will conform to all specifications and will perform as specified. Upon receipt of written notice of a defect in workmanship, the Contractor shall repair the defect in a timely manner at no expense to the Authority.

6. **WARRANTY ON GOODS PROVIDED:** The Contractor warrants its goods for a period of two (2) years from the date of final acceptance. Furthermore, the Contractor warrants that goods ordered to specifications will conform thereto and to any drawings, samples, or other description furnished or adopted by the Authority, and will be fit and sufficient for the purpose intended; and that all goods are merchantable, of good material and workmanship, and free from defect. Such warranties, together with the Contractor's service warranties and guarantees, if any shall survive inspection, test, acceptance of, and payment for the goods and shall run to the Authority, its successors, assigns, customers at any tier, and ultimate user and joint users. Notices of any defect or nonconformity shall be given by the Authority to the Contractor within fifteen (15) months after acceptance by ultimate user; provided however that in the event the goods are designed by the Contractor, notice must be given within three (3) years after acceptance by ultimate user. The rights and remedies of the Authority concerning latent defects shall exist indefinitely, and shall not be affected in clause. The Authority may, at its option, and in addition to other remedies available at law, either (i) return for credit, (ii) require prompt correction or replacement of the defective or nonconforming goods, or (iii) have the defective items corrected or replaced at the Contractor's expense and deduct the cost thereof from any monies due the Contractor. The return to the Contractor of any defective or nonconforming goods and delivery to the Authority of any corrected or replaced goods shall be at the Contractor's expense. Goods required to be corrected or replaced shall be at the Contractor's expense. Goods required to be corrected or replaced shall be subject to the provision of this paragraph and the paragraph of this Agreement entitled "inspection" on the same manner and to the same extent as goods originally delivered under this Agreement. In addition to correcting or replacing any defective or

Division 3

Contract Forms

Section 1: Agreement Form

nonconforming goods, the Contractor shall also reimburse the Authority for all costs and expenses incurred by the Authority in connection with inspection and discovery of the defects, identifying and correcting the cause of such defects and all other activities reasonably undertaken by the Authority to obtain conforming goods or attempting to obtain from the ultimate user a waiver to permit the defective goods to be used with all or part of the defective conditions.

7. **INSPECTION**: The Authority shall have the right to inspect the goods supplied hereunder at any time during the manufacture or fabrication thereof at the Contractor's facilities or elsewhere. Such inspection may include, without limitation, raw materials, components, work in process, and completed products as well as drawings, specifications, and released data. Final inspection and acceptance shall be after delivery to the delivery point designated by the Authority. If any inspection or test is made by the Authority at the Contractor's facility or elsewhere, the Contractor shall provide reasonable facilities and assistance for the inspection personnel. The Authority may reject all goods supplied hereunder, which are found to be defective. Goods so rejected may be returned to the Contractor at the Contractor's expense. No inspection, examination or test, regardless of extensiveness or type, and no approval give in connection with any such inspection, examination or test, whether under this Agreement or another contract for the same or similar goods, shall relieve it, of any obligation to comply fully with all requirements of this Agreement, including the obligation to produce goods that conform to all requirements of the drawings, specifications and any other Contract Documents. At the Authority's request, the Contractor shall repair or replace defective goods at the Contractor's expense. Failure to inspect goods, failure to discover defects in goods or payment for goods shall not constitute acceptance or limit any of the Authority's rights, including without limitation those under the WARRANTY provisions of this Agreement. In the event inspection reveals a defect or defects and schedule urgency requires that the defect or defects be corrected by the Authority to support production, all cost of such correction, including without limitation installation and removal, will be charged to the Contractor; such charges will also include time and material and appropriate indirect and overhead expenses. The Contractor shall maintain in inspection system acceptable to the Authority covering the goods furnished hereunder.

Division 3

Contract Forms

Section 1: Agreement Form

8. **CONTRACTOR'S AFFIDAVITS:** The Contractor shall issue a "Standard Contractor's Affidavit Interim Waiver and Release Upon Payment" and a "Standard Contractor's Affidavit Unconditional Waiver and Release upon Final Payment" provided by the Authority before receiving any interim or final payment for any services performed.
9. **ASSIGNMENT AND SUBCONTRACTING:** The Contractor shall not assign this Agreement or any portion of this Agreement, nor shall the Contractor sub contract for goods or completed or substantially completed services purchased hereunder without the prior express written consent of the Authority. No assignment or subcontract by the Contractor, including any assignment or subcontract to which the Authority consents, shall in any way relieve the Contractor from complete and punctual performance of this Agreement, including without limitation all of the Contractor's obligations under the WARRANTY provisions of this Agreement.
10. **THE AUTHORITY'S ASSISTANCE AND COOPERATION:** During the Contractor's performance of this Agreement, the Authority may, but has no obligation to, provide assistance to, or cooperate with, the Contractor in activities that facilitate the proper performance and completion of this Agreement by the Contractor. Such assistance and cooperation may include without limitation: (i) providing engineering or other analysis or advice on correcting problems; (ii) refraining from strict enforcement of time schedule requirements under this Agreement; (iii) permitting use of test materials or documentation not performed or produced under this Agreement. Such assistance or cooperation by the Authority shall not be construed, and the Contractor agrees that it will not claim that any such assistance or cooperation operates, to relieve the Contractor from complete, proper and punctual performance of all the Contractor's obligations under this Agreement.
11. **WORK ON THE AUTHORITY'S DESIGNATED PREMISES:** In the event that the Contractor, the Contractor's employees or agents or the Contractor's subcontractors enter the Authority's designated premises for any reason in connection with this Agreement, the Contractor and such other parties shall observe all security requirements and all plant safety, plant protection, and traffic regulations. The Contractor shall defend, indemnify, and hold the Authority harmless from all claims, actions, demands, loss, and causes of action, arising from injury, including death, to any person, or damage to any

Division 3

Contract Forms

Section 1: Agreement Form

property, when such injury or damage results in whole or in part from the acts or omissions of the Contractor, the Contractor's employees or agents or the Contractor's subcontractor, save and except damage caused by the sole negligence of the Authority. The Contractor, and any subcontractor's used by the Contractor in connection with this Agreement, shall carry Workmen's Compensation and Employees' Liability Insurance to cover the Contractor's and any subcontractor's legal liability on account of accidents to their employees. The Contractor and any subcontractor shall carry adequate Comprehensive General Liability and adequate Comprehensive Automobile Liability Insurance covering accidents to their employees. The Contractor and any subcontractor shall carry adequate Comprehensive General Liability and adequate Comprehensive Automobile Liability Insurance covering legal liability of the Contractor and any subcontractor on account of accidents arising out of the operations of the Contractor or any subcontractor and resulting in bodily injury, including death, being sustained by any person or persons, or in any damage to property. At the Authority's request, the Contractor shall furnish to the Authority certificates from the Contractor's insurers showing such coverage in effect and agreeing to give the Authority thirty (30) days prior written notice of cancellation of the coverage.

12. **RISK MANAGEMENT REQUIREMENTS:** The Contractor shall abide by the Authority's applicable Risk Management Requirements, attached to this Agreement as Exhibit A and hereby incorporated into this Agreement.
13. **TERMINATION FOR DEFAULT:**
 - (a) The Authority may, subject to the provisions of subparagraph (c) below, by written notice of default to the Contractor, terminate the whole or any part of this Agreement in any one of the following circumstances; (i) if the Contractor fails to perform this Agreement within the time specified herein or any extension thereof; or (ii) if the Contractor fails to perform any of the other provisions of this Agreement, or so fails to make progress as to endanger performance of this Agreement in accordance with its terms, and does not cure such failure within a period of ten (10) days or longer period (as the Authority may authorize in writing) after receipt of notice from the Authority specifying such failure.
 - (b) In the event the Authority terminates this Agreement in whole or in part as provided in subparagraph (a) above, the Authority may procure, upon such terms and in such manner as the Authority may deem appropriate, services, similar to those so terminated, and the Contractor

Division 3

Contract Forms

Section 1: Agreement Form

shall be liable to the Authority for any Excess costs for the same, including without limitation all cost and expenses of the type specified in the "WARRANTY" paragraph of this Agreement; provided, that the Contractor shall continue the performance of this Agreement to the extent not terminated hereunder.

- (c) Except with regard to defaults of subcontractors, the Contractor shall not be liable for any excess costs if the failure to perform this Agreement arises out of causes beyond the control and without the fault of negligence of the Contractor such causes may include, but are not limited to, acts of God, or of the public enemy, acts of the Government in either its sovereign or contractual capacity, fires, flood, epidemics, quarantine restrictions, strikes, freight embargoes, and unusually severe weather, but in every case the failure to perform must be beyond the control and without the fault or negligence of the Contractor. If the failure to perform is caused by the default of a subcontractor, and if such default arises out of causes beyond the control of both the Contractor and the subcontractor, and without the fault of negligence of either of them, the Contractor shall not be liable for any excess costs for failure to perform, unless the services to be furnished by the subcontractor were obtainable from other sources in sufficient time to permit the Contractor to meet the required delivery schedule. The term "subcontractor" shall mean subcontractor at any tier.
- (d) If, after notice of termination of this Agreement under the provisions of this paragraph, it is determined for any reason that the Contractor was not in default under the provisions above or that the default was excusable under the provisions of this paragraph, the rights and obligations of the parties shall be the same as if the notice of termination has been issued pursuant to the "Termination for Convenience" paragraph of this Agreement.
- (e) The rights and remedies of the Authority provided in this paragraph shall not be exclusive and are in addition to any other rights and remedies provided by law or under this Agreement.

14. **TERMINATION FOR CONVENIENCE:** The Authority may at any time by written notice terminate all or any part of this Agreement for the Authority's convenience. If this Agreement is terminated, in whole or in part, for the Authority's convenience, the Contractor shall be paid an amount, to be mutually agreed upon, which shall be adequate to cover the actual and

Division 3

Contract Forms

Section 1: Agreement Form

reasonable cost paid by the Contractor for the actual goods and labor reasonably used by the Contractor to perform the work under this Agreement to the effective date of termination, plus a reasonable profit thereon; provided that no amount shall be paid to the Contractor for (i) any anticipatory profits related to work under this Agreement not yet performed, or (ii) costs incurred due to the Contractor's failure to terminate work as ordered on the effective date of termination. In no event shall the total amount paid under the provisions of this paragraph exceed the prices set forth in this Agreement for the work terminated.

15. **DISPUTES:** Pending resolution of any dispute hereunder, the Contractor shall proceed diligently with the performance of work in accordance with the Authority's direction.
16. **NOTICES:** All notices required or permitted to be given hereunder shall be deemed to be properly given if delivered in writing personally or sent by United States certified or registered mail addressed to the Contractor or the Authority, as the case may be, with postage thereon fully prepaid. The effective time shall be at the time of mailing.
17. **ATTORNEYS' FEES:** The Contractor shall pay reasonable attorneys' fees to the Authority should the Authority be required to incur attorneys' fees in enforcing the provisions of this Agreement or in the collection of any monies herein required to be paid by the Contractor to the Authority.

SIGNATURES ON NEXT PAGE

Division 3

Contract Forms

Section 1: Agreement Form

IN WITNESS WHEREOF this _____ day of _____,
20_____, said parties have hereunto set their seals the day and year above first written.
Executed on behalf of:

CLAYTON COUNTY WATER AUTHORITY

BY: _____

TITLE:

[Corporate Seal]

ATTEST: _____

DATE: _____

CONTRACTOR

BY: _____

TITLE:

[Corporate Seal]

ATTEST: _____
Corporate Secretary

DATE: _____

Division 3

Contract Forms

Section 1: Agreement Form

RISK MANAGEMENT REQUIREMENTS

The Contractor will provide minimum insurance coverage and limits as per the following: The Contractor will file with the Authority Certificates of Insurance, certifying the required insurance coverage and stating that each policy has been endorsed to provide thirty (30) day notice to the Authority in the event that coverage is cancelled, non-renewed or the types of coverage or limits of liability are reduced below those required. All bonds and insurance coverage must be placed with an insurance company approved by Authority Management, admitted to do business in the State of Georgia, and rated Secure (“B+” or better) by A.M. Best Company in the latest edition of Property and Casualty Ratings, or rated by Standard & Poors Insurance Ratings, latest edition as Secure (“BBB” or better). Worker’s Compensation self-insurance for individual Contractors must be approved by the Worker’s Compensation Board, State of Georgia and/or Self-Insurance pools approved by the Insurance Commissioner, State of Georgia.

CONTRACTS FOR UP TO \$50,000

Worker’s Compensation – Worker’s Compensation coverage on a statutory basis for the State of Georgia with an Employer’s Liability limit of \$100,000 each Accident, Disease \$100,000 each employee, \$500,000 Disease policy limit.

Automobile Liability – Automobile liability coverage for owned, hired and non-owned vehicles in the amount of \$500,000 combined single limit.

Commercial General Liability – Coverage to be provided on “occurrence” not “claims made” basis. The coverage is to include Contractual liability, Per Project Limit of Liability, losses caused by Explosion, Collapse and Underground (“xcu”) perils, the “Clayton County Water Authority” is to be added as an Additional Insured and Products and Completed Operations coverage is to be maintained for three (3) years following completion of work.

CONTRACTS FOR MORE THAN \$50,000

Worker’s Compensation – Worker’s Compensation coverage on a statutory basis for the State of Georgia with an Employer’s Liability limit of \$1,000,000. The increased Employer’s Liability limit may be provided by an Umbrella or Excess Liability policy.

Automobile Liability - Automobile liability coverage for owned, hired and non-owned vehicles in the amount of \$1,000,000 combined single limit.

Commercial General Liability – Coverage to be provided on “occurrence” not “claims made” basis. The coverage is to include Contractual liability, Per Project Limit of Liability, losses caused by Explosion, Collapse and Underground (“xcu”) perils, the “Clayton County Water Authority” is to be added as an Additional Insured and Products and Completed Operations coverage is to be maintained for three (3) years following completion of work.

Division 3

Contract Forms

Section 1: Agreement Form

RISK MANAGEMENT REQUIREMENTS (Cont'd)

CONTRACTS FOR UP TO \$50,000

CONTRACTS FOR MORE THAN \$50,000

LIMITS OF LIABILITY:

\$1,000,000	Per Occurrence
\$1,000,000	Personal and Advertising
\$50,000	Fire Damage*
\$5,000	Medical Payments*
\$1,000,000	General Aggregate
\$1,000,000	Products/Completed Operations per Occurrence and Aggregate

**These are automatic minimums*

Owner's Protective Liability – The Authority's Management may, in its discretion, require Owner's Protective Liability in some situations.

Umbrella and/or Excess Liability – The umbrella or Excess Liability Policy may be used to combine with underlying policies to obtain the limits required. The Management of the Authority may elect to require higher limits.

Owner's Protective Liability – The Authority's Management may, in its discretion, require Owner's Protective Liability in some situations.

END OF SECTION

Division 3

Contract Forms

Section 4: Non-Collusion Certificate

STATE OF _____, COUNTY OF _____

Personally appeared before the undersigned officer duly authorized by law to administer oaths

_____ who, after being first duly sworn, depose and say that they are all the officers, agents, persons or employees who have acted for or represented _____

_____ in procuring the Contract with the Clayton County Water Authority on the following Project: **Annual Contract for Fence Installations and Repairs** and that said _____ has not by (himself, themselves) or through any persons, officers, agents or employees prevented or attempted to prevent by any means whatsoever competition in such bidding; or by any means whatsoever prevented or endeavored to prevent anyone from making a proposal therefore, or induced or attempted to induce another to withdraw a bid for said work.

ATTEST:

By: _____
Bidder

By: _____
Name

By: _____
Name

Title: _____

Title: _____

Sworn to and subscribed before me this _____ day of _____, 20____

Notary Public: _____

My Commission expires: _____

END OF SECTION

Division 4 **Specifications**

Section 1: Post Award Submittals

1.1 General

- A. This section describes the information that is required to be provided by the Contractor to facilitate work.
- B. Contractor shall submit, to the CCWA for approval to use, product information on all materials required to be provided by the Contractor unless noted otherwise.
 - 1. Where a material manufacturer is not specified, Contractor shall submit for use domestically manufactured materials.
 - 2. Materials provided by the Contractor not approved by the CCWA shall be subject to rejection without further justification.
- C. The Contractor shall schedule and make submissions as to cause no delay in work.
- D. Upon receipt of a submittal, the CCWA shall complete its review and return CCWA comments to Contractor within 10 business days.

1.2 Submittal Requirements

- A. Submittals to be provided with each individual Project Work Order.
 - 1. Specifications of materials being supplied (as necessary).

END OF SECTION

Division 4 **Specifications**

Section 2: Work Assignment and Detail

2.1 General

- A. This Section describes how work is to be assigned and the basis that will be used for processing applications for payment. These provisions will apply to all work of the Contract Documents in addition to specific instructions provided within the individual specification sections.
- B. The basis for payment will be the bid unit cost amounts included in the Pay Item Schedule and the actual quantities of work completed by the Contractor and approved by the CCWA. The CCWA reserves the right to adjust the quantities up or down as necessary to address needs.
- C. Nothing in this Section shall be construed as providing for additional payment beyond the Work Items. No payment will be made for partially completed Work Items. No payment will be made for the completion of excessive quantities of a Work Item as determined by the CCWA.

2.2 Work Assignment and Detail

- A. Work to be performed under this annual contract will be assigned on an as needed when needed basis as determined by the CCWA in the form of a Project Work Order.

Project Set-Up for Non-Emergency Work

- 1. CCWA shall prepare draft work items and quantities for Contractor review.
- 2. Contractor shall provide comments on the draft work items and quantities to CCWA within 7 calendar days of issuance by CCWA in order that a Project Work Order can be issued.
- 3. Contractor shall commence work on-site within 7 calendar days of receipt of a Project Work Order.

Project Set-Up for Emergency Work

- 1. CCWA shall prepare draft work items and quantities for Contractor review.
- 2. Contractor shall provide comments on the draft work items and quantities to CCWA within 24 hours of notice of emergency mobilization by CCWA in order that a Project Work Order can be issued.
- 3. Contractor shall commence work on-site within 24 hours of notice of emergency mobilization by CCWA. CCWA shall issue Project Work Order prior to or concurrently with the start of work.

Division 4

Specifications

Section 2: Work Assignment and Detail

- B. A Project Work Order will be for work items that are at a single location (particular address).
- C. Work of a Project Work Order shall be completed within the number of consecutive work days mutually agreed to by the Contractor and the CCWA prior to the start of the work. Unless approved by the CCWA in advance, the Contractor shall not leave the work site to complete work for others.

2.3 Work Items and Measurement

The following descriptions explain the work that is to be completed as part of each Work Item. The Contractor shall provide all labor, equipment, tools and materials to complete the Work Items in accordance with the Contract Documents. The following Work Items correspond to the Work Items and Details listed on the "Pay Item Schedule" of the Bid Form.

- A. **Work Item #1 "Emergency Mobilization".**
Defined as the Contractor's administrative and preparatory operations which are necessary to arrive on-site and initiate work within 24 hours of a notice of an Emergency Mobilization request. The Work Item will be paid on a per "each" unit cost in accordance with the Pay Item Schedule when applicable as authorized/approved by CCWA. The costs for demobilization, and re-mobilizations due to shut downs or suspensions of the work caused by the Contractor shall not be compensated.
- B. **Work Items #2 - #14 "Field Fence": Install Corner / Brace Post and Horizontal Brace.**
Defined as installing a corner/brace post or a horizontal brace in accordance with the appropriate material specifications and details and removing from the work site and disposing any remaining soil and/or other construction related materials/debris. The Work Items will be paid on a per "each" (EA) unit cost in accordance with the Pay Item Schedule and applicable Detail as authorized/approved by CCWA.
- C. **Work Items #2 - #14 "Field Fence": Install Fencing.**
Defined as installing barbed wire, line posts and fasteners in accordance with the appropriate material specifications and details and removing from the work site and disposing any remaining soil and/or other construction related materials/debris. The Work Items will be paid on a per "each" (EA) unit cost for up to the first 12 feet installed and on a per "linear foot" (LF) unit

Division 4

Specifications

Section 2: Work Assignment and Detail

cost for footage installed beyond 12 feet in accordance with the Pay Item Schedule and applicable Detail as authorized/approved by CCWA.

- D. **Work Items #2 - #14 “Field Fence”: Remove Existing Fencing.**
Defined as removing from the work site and disposing all existing posts, braces, barbed wire, fasteners and/or other construction related materials/debris. Any holes remaining from post removal shall be filled with dry sand. The Work Items will be paid on a per “linear foot” (LF) unit cost in accordance with the Pay Item Schedule and applicable Detail as authorized/approved by CCWA.
- E. **Work Items #15 - #110 “Chain-Link Fence”: Install Fencing.**
Defined as installing wire mesh, tension wire, barbed wire where requested, line post, top rail, accessories and fasteners in accordance with the appropriate material specifications and details and removing from the work site and disposing any remaining soil and/or other construction related materials/debris. The Work Items will be paid on a per “each” (EA) unit cost for up to the first 10 feet installed and on a per “linear foot” (LF) unit cost for footage installed beyond 10 feet in accordance with the Pay Item Schedule and applicable Detail as authorized/approved by CCWA.
- F. **Work Items #15 - #110 “Chain-Link Fence”: Install Corner/Pull Post.**
Defined as installing a corner/pull post, corner/pull post for barbed wire where requested, accessories and fasteners in accordance with the appropriate material specifications and details and removing from the work site and disposing any remaining soil and/or other construction related materials/debris. The Work Items will be paid on a per “each” (EA) unit cost in accordance with the Pay Item Schedule and applicable Detail as authorized/approved by CCWA.
- G. **Work Items #15 - #110 “Chain-Link Fence”: Install Walk Gate.**
Defined as installing a single-swing walk gate, single walk gate with barbed wire where requested, accessories and fasteners in accordance with the appropriate material specifications and details and removing from the work site and disposing any remaining soil and/or other construction related materials/debris. The Work Items will be paid on a per “each” (EA) unit cost in accordance with the Pay Item Schedule and applicable Detail as authorized/approved by CCWA.

Division 4

Specifications

Section 2: Work Assignment and Detail

- H. **Work Items #15 - #110 “Chain-Link Fence”: Install Drive Gate.**
Defined as installing a double-swing drive gate, double-swing drive gate with barbed wire where requested, accessories and fasteners in accordance with the appropriate material specifications and details and removing from the work site and disposing any remaining soil and/or other construction related materials/debris. The Work Items will be paid on a per “each” (EA) unit cost in accordance with the Pay Item Schedule and applicable Detail as authorized/approved by CCWA.
- I. **Work Items #15 - #110 “Chain-Link Fence”: Remove Existing Fencing.**
Defined as removing from the work site and disposing all existing posts, braces, top rails, wire mesh, barbed wire where requested, single-swing walk gates, double-swing drive gates, accessories, fasteners and/or other construction related materials/debris. Any holes remaining from post removal shall be filled with dry sand. The Work Items will be paid on a per “linear foot” (LF) unit cost in accordance with the Pay Item Schedule and applicable Detail as authorized/approved by CCWA.
- J. **Work Items #15 - #110 “Chain-Link Fence”: Install Horizontal Brace.**
Defined as installing a horizontal brace, truss rod, accessories and fasteners in accordance with the appropriate material specifications and details and removing from the work site and disposing any remaining soil and/or other construction related materials/debris. The Work Items will be paid on a per “each” (EA) unit cost in accordance with the Pay Item Schedule and applicable Detail as authorized/approved by CCWA.
- K. **Work Items #111 - #113 “Chain-Link Fence (Temporary)”: Install / Remove Fencing.**
Defined as installing temporary galvanized mesh fencing up to a height of 6 feet, corner posts, line posts, top rail, tension wire, accessories and fasteners and subsequently removing all fencing materials from the work site and disposing any remaining soil and/or other construction related materials/debris. Any holes remaining from post removal shall be filled with dry sand. The Work Items will be paid on a per “linear foot” (LF) unit cost in accordance with the Pay Item Schedule and applicable Detail as authorized/approved by CCWA.

Division 4

Specifications

Section 2: Work Assignment and Detail

- L. **Work Items #114 - #129 “Wood Privacy Fence”: Install Fencing.**
Defined as installing wood runners, wood slats and fasteners in accordance with the appropriate material specifications and details and removing from the work site and disposing any remaining soil and/or other construction related materials/debris. The Work Items will be paid on a per “each” (EA) unit cost for up to the first 8 feet installed and on a per “linear foot” (LF) unit cost for footage installed beyond 8 feet in accordance with the Pay Item Schedule and applicable Detail as authorized/approved by CCWA.
- M. **Work Items #114 - #129 “Wood Privacy Fence”: Install Post.**
Defined as installing a post in accordance with the appropriate material specifications and details and removing from the work site and disposing any remaining soil and/or other construction related materials/debris. The Work Items will be paid on a per “each” (EA) unit cost in accordance with the Pay Item Schedule and applicable Detail as authorized/approved by CCWA.
- N. **Work Items #114 - #129 “Wood Privacy Fence”: Install Walk Gate.**
Defined as installing a single-swing walk gate, accessories and fasteners in accordance with the appropriate material specifications and details and removing from the work site and disposing any remaining soil and/or other construction related materials/debris. The Work Items will be paid on a per “each” (EA) unit cost in accordance with the Pay Item Schedule and applicable Detail as authorized/approved by CCWA.
- O. **Work Item #114 - #129 “Wood Privacy Fence”: Install Drive Gate.**
Defined as installing a double-swing drive gate, accessories and fasteners in accordance with the appropriate material specifications and details and removing from the work site and disposing any remaining soil and/or other construction related materials/debris. The Work Item will be paid on a per “each” (EA) unit cost in accordance with the Pay Item Schedule and applicable Detail as authorized/approved by CCWA.
- P. **Work Items #114 - #129 “Wood Privacy Fence”: Remove Existing Fencing.**
Defined as removing from the work site and disposing all existing posts, slats, runners, single-swing walk gates, accessories, fasteners and/or other construction related materials/debris. Any holes remaining from post removal shall be filled with dry sand. The Work Items will be paid on a per

Division 4

Specifications

Section 2: Work Assignment and Detail

“linear foot” (LF) unit cost in accordance with the Pay Item Schedule and applicable Detail as authorized/approved by CCWA.

Q. Work Items #130 - #132 “Hourly Labor”: 1,2,3 Man Crew.

Work Items shall be utilized on a case-by-case basis. Defined as the Contractor providing and utilizing the indicated number of labor positions to complete work as requested for a certain amount of time. Work Items may only be used when work cannot be completed through other existing Work Items. Only the time the labor position is on the work site and working will be considered for payment. The hourly rate shall be the Contractor’s total expense per hour for the indicated number of labor positions. The Work Items will be paid on a per “hour” unit cost in accordance with the Pay Item Schedule and applicable Detail as authorized/approved by CCWA.

R. Work Item #133 “Special Material”.

Work Item shall be utilized on a case-by-case basis. Defined as the Contractor furnishing material, not included as part of other Work Items, needed to complete the work. The Work Item will be paid at invoice cost plus a Contractor’s 10% percent markup in accordance with the Pay Item Schedule as authorized/approved by CCWA.

END OF SECTION

Division 4

Specifications

Section 3: General Requirements

3.1 General

- A. This section describes general requirements of the Contract.
- B. The Contractor shall provide all staff with photo identification and use vehicles with permanent company logos/markings/identification that are prominently displayed and clearly visible at all times.
- C. The Contractor shall provide an experienced supervisor in charge of field operations and subcontractors. The field supervisor shall be responsible for the safety of all site workers and site conditions, as well as ensuring that all work is conducted in conformance with these Specifications and to the level of quality specified. The field supervisor shall be responsible for reporting any safety or regulatory issue of concern immediately to CCWA.
- D. The Contractor shall use special care in work methods and take all necessary precautions against improper use of equipment to avoid damaging CCWA, public and private property. If, in CCWA's opinion, the Contractor's work has caused damage, the Contractor shall repair the damage timely and to the complete satisfaction of CCWA at no additional cost. In the event that funds are expended by CCWA related to these activities the Contractor shall reimburse CCWA for any and all such costs.
- E. The CCWA shall not be responsible or compensate the Contractor for the damage to and/or loss of Contractor's equipment as result of the work.

3.2 Site Work

- A. Work on a site shall be allowed Monday through Friday from 7:30 am to 6:00 pm; other times may be allowed by CCWA permission only.
- B. The Contractor shall be responsible for locating existing utilities in accordance with state and local regulations.
- C. The Contractor shall be responsible for providing and maintaining a safe work site as necessary to protect the workers and the public at all times.
- D. The work may require access to private property. The CCWA shall be responsible for coordinating and providing access to the area(s) of work. The Contractor shall contain work within area designated by CCWA.
- E. The work may be accessed on paved surfaces or non-paved surfaces. Contractor shall provide equipment capable of maneuvering all surfaces.

Division 4

Specifications

Section 3: General Requirements

CCWA shall not be responsible for Contractor's equipment that becomes un-manueverable due to site conditions.

- F. The Contractor shall maintain the work site in a neat and orderly condition throughout the construction period. Remove and dispose of all construction related debris in accordance with local and state regulations. The burning of materials is not permitted on the work site or other CCWA property. At completion of work, remove temporary facilities, debris and equipment.

3.3 Material Specifications

A. Field Fence

1. Wood Post: Corner, brace and line post shall be pressure treated southern yellow pine. Preservative shall be waterborne and suitable for ground contact in accordance with the American Wood Protection Association (AWPA). Sized as follows:
 - a. Corner / Brace Post: 6-inch diameter at small end by 7-foot length.
 - b. Horizontal Brace: 4-inch diameter at small end by 7-foot length.
 - c. Line Post: 3-inch diameter at small end by 6.5-foot length.
2. Steel Post: Line post shall be Standard T-post Non-Certified 1.25 pound/foot, studded with anchor plate. Steel shall be coated with baked-on enamel.
3. Barbed Wire Strand: Strand shall consist of two 12.5 gauge carbon-steel wires galvanized zinc-coated (Class 1). Strand shall have barbs (4-point) spaced at 5 inches on-center, galvanized zinc-coated.
4. Fasteners:
 - a. Staple shall be 8 gauge carbon-steel wire double-barbed galvanized zinc-coated, 1.5 inches long.
 - b. Horizontal brace pin shall be 3/8-inch diameter carbon-steel galvanized zinc-coated, 5 inches long minimum.
 - c. Wire clip for T-post shall be minimum 8 gauge carbon-steel wire galvanized zinc-coated.
5. See "Field Fence – Barbed Wire" Detail for dimensional requirements.

Division 4

Specifications

Section 3: General Requirements

B. Chain-Link Fence (4-Foot and 5-foot Heights)

1. Post: Corner post, pull post, line post and top rail shall be 16 gauge steel tubing galvanized zinc coated. Plastic coating shall be extruded vinyl; color as requested. Sized as follows:
 - a. Corner / Pull Post: 2-3/8 inch diameter.
 - b. Line Post: 1-5/8 inch diameter.
 - c. Top Rail: 1-5/8 inch diameter.
2. Chain-Link: Size shall be 11.5 gauge galvanized zinc coated with 2-inch openings or match existing. Finish size with plastic coating shall be 9 gauge. Plastic coating shall be extruded vinyl, color as requested.
3. Tension Wire: Wire size shall be 7 gauge galvanized zinc coated. Finish size with plastic coating shall be 4 gauge. Plastic coating shall be extruded vinyl, color as requested.
4. Accessories and Fasteners: Caps, clips, bands, pull bars, latches, canes, hinge pins and fasteners shall be galvanized zinc coated. Where used with plastic coated chain-link, caps, clips, bands, pull bars, latches shall be coated with extruded vinyl. Where used with plastic coated chain-link, canes, hinge pins and fasteners shall be finished with a coating compatible with galvanization, color as requested.
5. See "Chain Link Fence – 4' and 5'" Detail for dimensional requirements.

C. Chain-Link Fence (6-Foot and 8-foot Heights)

1. Post: Corner post, pull post, line post, top rail and horizontal brace shall be schedule 40 steel tubing galvanized zinc coated. Plastic coating shall be extruded vinyl; color as requested. Sized as follows:
 - a. Corner / Pull Post: 3 inch diameter.
 - b. Line Post: 2-1/2 inch diameter.
 - c. Horizontal Brace: 2-1/2 inch diameter.
 - d. Top Rail: 1-5/8 inch diameter.
2. Chain-Link: Size shall be 9 gauge galvanized zinc coated with 2-inch openings or match existing. Finish size with plastic coating shall be 6 gauge. Plastic coating shall be extruded vinyl, color as requested.

Division 4

Specifications

Section 3: General Requirements

3. Truss Rod: Rod size shall be 3/8-inch diameter galvanized zinc coated. Where required, plastic coating shall be extruded vinyl, color as requested.
 4. Tension Wire: Wire size shall be 7 gauge galvanized zinc coated. Finish size with plastic coating shall be 4 gauge. Plastic coating shall be extruded vinyl, color as requested.
 5. Barbed Wire Strand: Strand shall consist of two 12.5 gauge carbon-steel wires galvanized zinc-coated (Class 1). Strand shall have barbs (4-point) spaced at 5 inches on-center, galvanized zinc-coated. Where used with plastic coated chain-link, finish with coating compatible with galvanization, color as requested.
 6. Accessories and Fasteners: Caps, barbed wire arm, clips, bands, pull bars, latches, canes, hinge pins and fasteners shall be galvanized zinc coated. Where used with plastic coated chain-link, caps, clips, bands, pull bars, latches shall be coated with extruded vinyl. Where used with plastic coated chain-link, barbed wire arms, canes, hinge pins and fasteners shall be finished with a coating compatible with galvanization, color as requested.
 7. See "Chain Link Fence – 6' and 8'" and "Chain Link Fence – 6' and 8' with Barbed Wire" Details for dimensional requirements.
- D. Wood Privacy Fence
1. Wood: Posts, runners and slats shall be pressure treated southern yellow pine. Preservative shall be waterborne and suitable for ground contact in accordance with the American Wood Protection Association (AWPA). Sized as follows:
 - a. Post: 4-inch by 4-inch (nominal).
 - b. Runner: 2-inch by 4-inch (nominal).
 - c. Slat: 1-inch by 6-inch (nominal).
 2. Accessories and Fasteners:
 - a. Latches, hinges, canes, bolts, nails and fasteners shall be galvanized coated.

Division 4

Specifications

Section 3: General Requirements

3. See “Wood Privacy Fence – Stockade”, “Wood Privacy Fence – Stockade Curved Top” and “Wood Privacy Fence – Shadow Box” Details for dimensional requirements.

E. Concrete

1. Fast-setting commercial grade having minimum 3,000 psi compressive strength. Premixed sack-type mixture is acceptable.

3.4 Acceptance

- A. A CCWA Inspector shall inspect all components of work for compliance with the Contract. The Contractor shall, at all times, permit and facilitate inspection of work by the CCWA. The presence of a CCWA Inspector or other CCWA staff on the site of work shall not be construed to, in any manner, relieve the Contractor of their responsibility for strict compliance with the Contract. The CCWA Inspector shall inform the Contractor when work is deficient from the Contract. Deficiencies shall be addressed in a timely manner as determined by the CCWA Inspector.
- B. Final Acceptance of the work by the CCWA shall be when the Contractor has met all terms and conditions as set forth by the Contract. The date of Final Acceptance shall be no later than the date the CCWA approves the Contractor’s final request for payment. Where applicable, Final Acceptance shall be written, signed and dated by the CCWA.

END OF SECTION

ATTACHMENTS

**STATE OF GEORGIA
COUNTY OF CLAYTON**

WAIVER AND RELEASE UPON FINAL PAYMENT

The undersigned mechanic and/or materialman has been employed by the Clayton County Water Authority to furnish:

_____ [describe materials
and/or labor];

for the construction of improvements known as:

_____ [title of the project or building];

which is owned by the Clayton County Water Authority at the following address:

and more particularly described by the following metes and bounds description, land lot district, or block and lot number:

See Attachment: yes no

Upon the receipt of the sum of: \$ _____ ;

the mechanic and/or materialman waives and releases any and all liens or claims of liens or any right against any labor and/or material bond it has upon the foregoing described property.

THE MECHANIC AND/OR MATERIALMAN WAIVES AND RELEASES ANY AND ALL LIENS OR CLAIMS OF LIENS IT HAS UPON THE FOREGOING DESCRIBED

PROPERTY OR ANY RIGHTS AGAINST ANY LABOR AND/OR MATERIAL BOND ON ACCOUNT OF LABOR OR MATERIALS, OR BOTH, FURNISHED BY THE UNDERSIGNED TO OR ON ACCOUNT OF SAID CONTRACTOR FOR SAID PROPERTY.

NOTICE: WHEN YOU EXECUTE AND SUBMIT THIS DOCUMENT, YOU SHALL BE CONCLUSIVELY DEEMED TO HAVE BEEN PAID IN FULL THE AMOUNT STATED ABOVE, EVEN IF YOU HAVE NOT ACTUALLY RECEIVED SUCH PAYMENT, 60 DAYS AFTER THE DATE STATED ABOVE UNLESS YOU FILE EITHER AN AFFIDAVIT OF NONPAYMENT OR A CLAIM OF LIEN PRIOR TO THE EXPIRATION OF SUCH 60 DAY PERIOD.

PERSONALLY APPEARED BEFORE ME, the undersigned attesting officer, duly authorized by law to administer oaths (the "Deponent"), who being duly sworn according to law, deposes and says on oath:

1. That Deponent is the duly authorized agent and duly elected and acting officer of _____ (the "Contractor"), and is duly authorized to execute this Final Contractor's Affidavit, Lien Waiver and Indemnification (this "Affidavit") in a representative capacity on behalf of Contractor, as well as in Deponent's individual capacity, and Deponent has made diligent inquiry into and is personally familiar with and has full knowledge of all facts set forth herein.

2. That Contractor acted as the sole general contractor in charge of and directly responsible for the building and construction of all improvements (the "Work") located as reflected above (the "Property"), all of which Work was performed pursuant to the terms of that certain agreement dated _____ (the "Agreement") by and between Contractor and the Clayton County Water Authority as the owner or agent of the owner of the Property (the "Owner"). The Work includes, without limitation, all Work under or related to the Agreement and all change orders to the Agreement, and all supplemental contracts and subcontracts, whether oral or written, for any extra, additional or replacement labor or materials. Contractor is, and performed the Work as, an independent general contractor and Contractor is not an agent of Owner, and all of the Work was furnished and performed at the instance of Contractor as general contractor.

3. That the Work has been fully and finally completed in strict accordance with the terms of the Agreement, and Contractor has at all times since the commencement of the Work been in direct charge of all aspects of the Work, and Contractor has obtained a current valid permanent certificate of occupancy for the Property and the Work, and the Work has been completed within the boundary lines of the Property.

4. Upon receipt of the sum reflected above, Contractor acknowledges that Owner has paid in full to Contractor the full contract price under the Agreement (the "Contract Price"), which Contract Price includes, without limitation, all amounts and bills for all labor, materials, fixtures and supplies of any type whatsoever used in the Work. Upon receipt of these monies, all contractors, subcontractors, subcontractors of subcontractors, materialmen, suppliers and laborers will be paid in full the agreed price or reasonable value for all materials and supplies ordered, used or furnished and services and labor rendered in connection with or as a part of the Work, and none of such parties have or will have any claim, demand or lien against the Property, and all of the amounts paid by Owner to Contractor under the Agreement have been and will be used to pay for labor or materials used in the Work when no liens or claims of lien were filed or outstanding. There are no disputes regarding the Agreement or any other contracts or subcontracts with respect to the Work or the Property, and, except for bills associated with these final monies, there are no amounts due or unpaid bills of any nature, either for labor or services related to the Work or the Property or any materials which have been or may have been placed upon, or applied or delivered to the Property, and Contractor does hereby unconditionally agree to hold harmless and indemnify Owner from and against all claims for mechanic's or materialman's liens or claims of lien, including, without limitation, any attempted foreclosure thereof, which in any way arise out of or are related to the Work or the Property, including, without limitation, any attorney's fees incurred in connection therewith.

5. That Contractor does hereby for itself, and its employees, suppliers, subcontractors, mechanics and materialmen and all other persons acting for, through, or under Contractor, waive, remise, relinquish and release all right to file or to have filed or to maintain any materialman's or mechanic's lien or liens or claim or claims against the Property or arising out of or related to the Work. This Affidavit is executed and given in favor of and for the benefit of, and may be relied upon by, Owner and each and every party legally or equitably, now or hereafter, owning or holding any interest in the Property.

6. That this Affidavit is a sworn statement made under the provisions of Official Code of Georgia Annotated Section 44-14-361.2 and is made for the purpose of inducing Owner to pay to Contractor the balance of the Contract Price pursuant to the terms of the Agreement.

_____(L.S.)
(Signature of Deponent)

(Printed/Typed Name and Title)

Deponent, individually, and as duly authorized agent and duly elected and acting officer of Contractor

(Company Name)

PERSONALLY APPEARED BEFORE ME, a Notary Public in and for said State and County, the Deponent, who, being personally known to the undersigned and being duly sworn and on oath deposed and said that the within and foregoing statements are true and correct this _____ day of _____, 20_____.

Notary Public _____

Commission Expiration Date: _____

(NOTARY SEAL)

(Witness)

(Address)

DETAILS

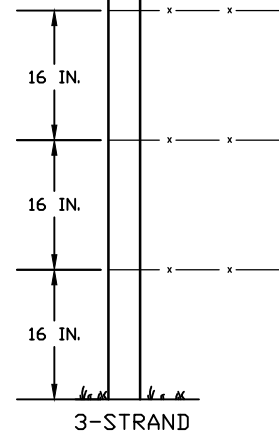
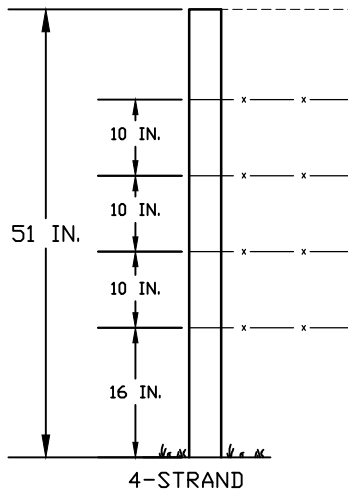
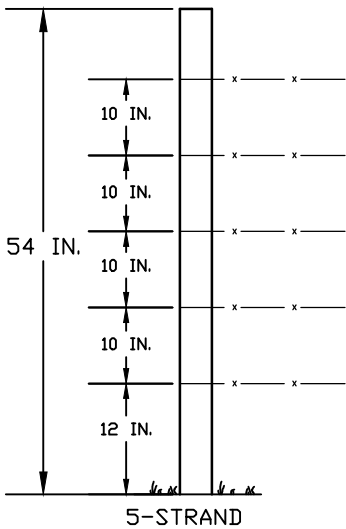
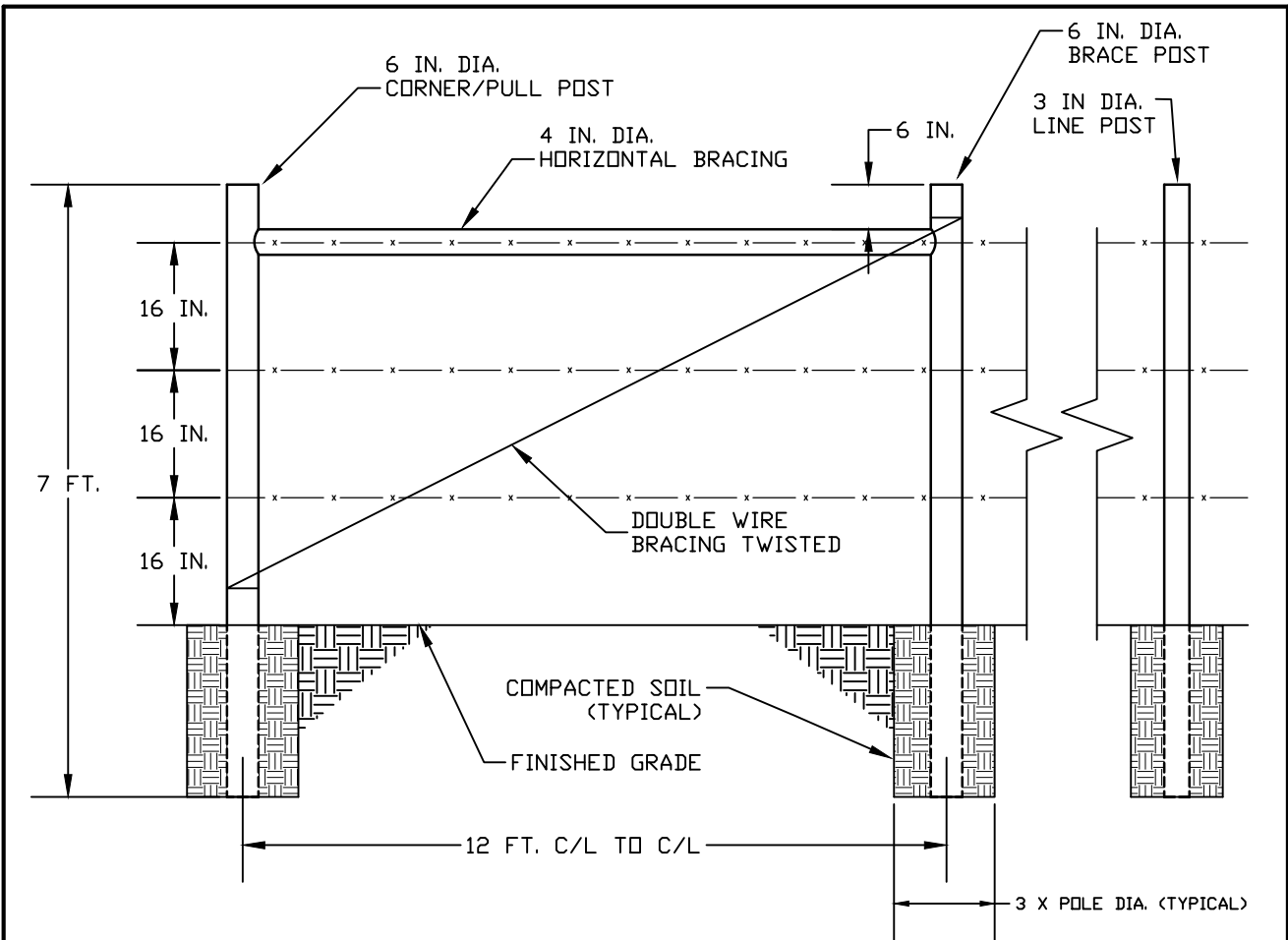

CLAYTON COUNTY WATER AUTHORITY

DATE:	12 AUGUST 2013
SCALE:	N.T.S.
DRAWN BY:	WWB

DETAIL TITLE:
FIELD FENCE BARBED WIRE

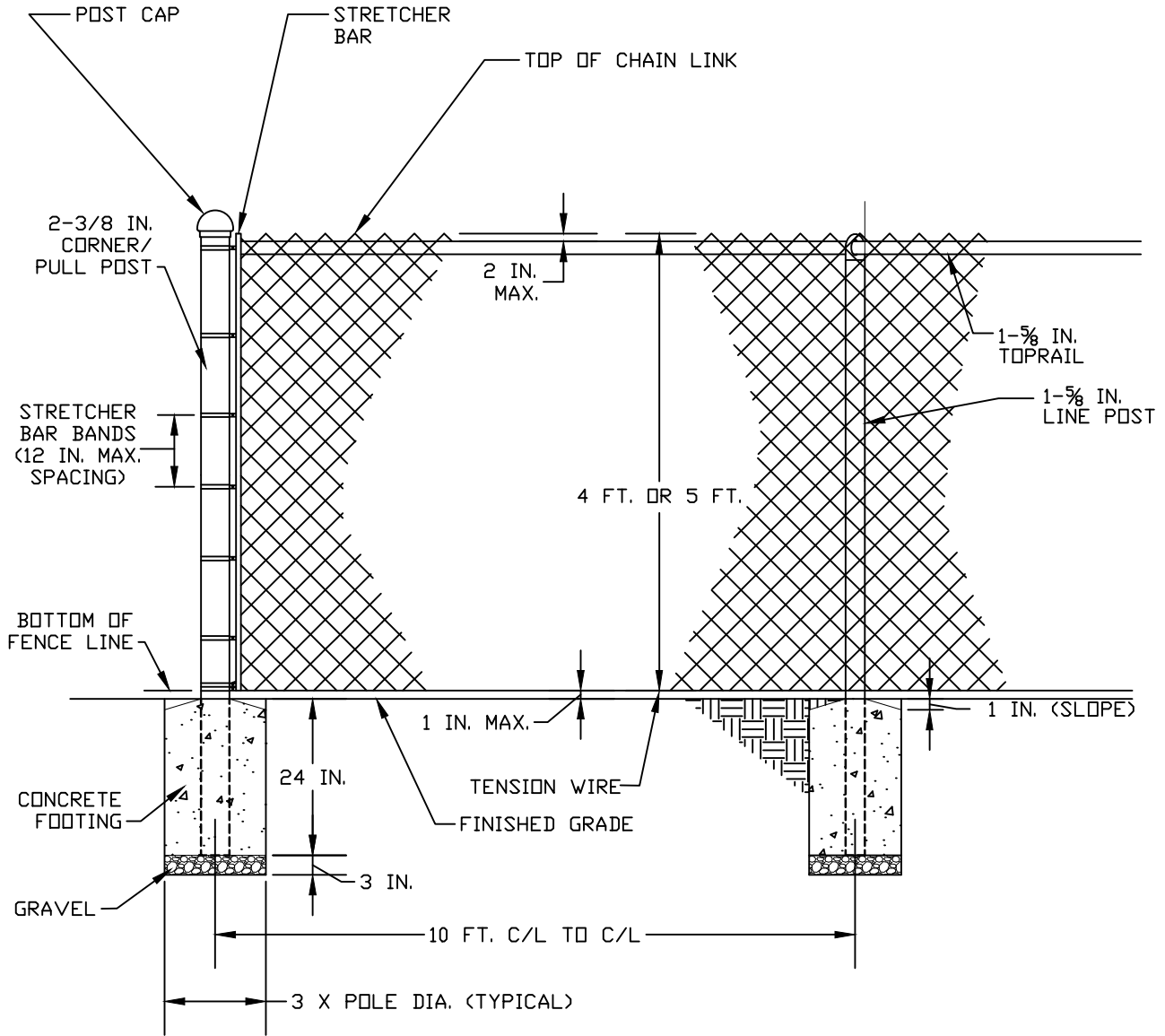

CLAYTON COUNTY WATER AUTHORITY

DATE:	12 AUGUST 2013
SCALE:	N.T.S.
DRAWN BY:	WWB

DETAIL TITLE:
CHAIN LINK FENCE 4' AND 5'

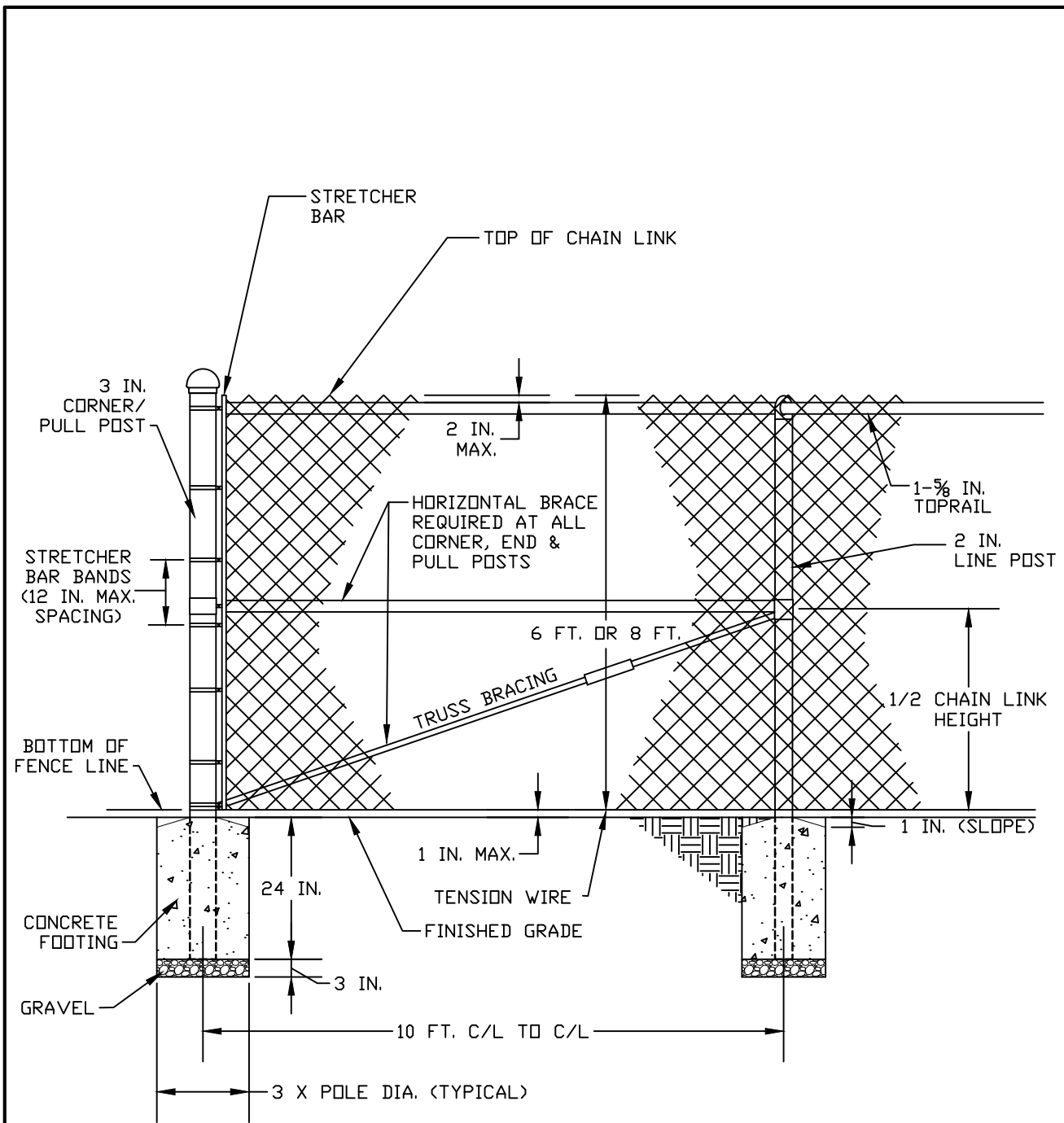

CLAYTON COUNTY WATER AUTHORITY

DATE:	12 AUGUST 2013	DETAIL TITLE:
SCALE:	N.T.S.	CHAIN LINK FENCE 6' AND 8'
DRAWN BY:	WWB	

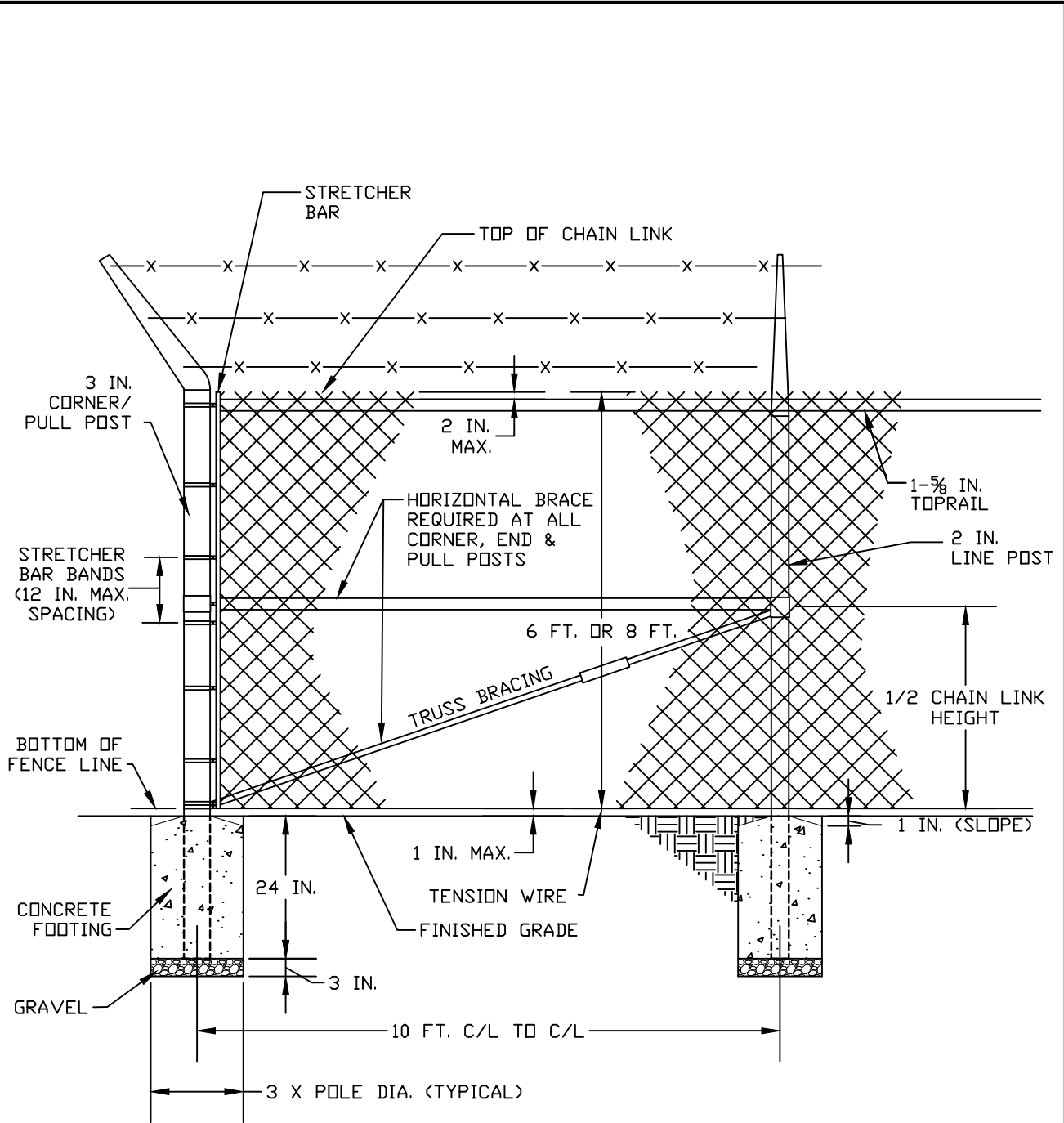

CLAYTON COUNTY WATER AUTHORITY

DATE:	12 AUGUST 2013	DETAIL TITLE:
SCALE:	N.T.S.	CHAIN LINK FENCE 6' AND 8' WITH BARBED WIRE
DRAWN BY:	WWB	

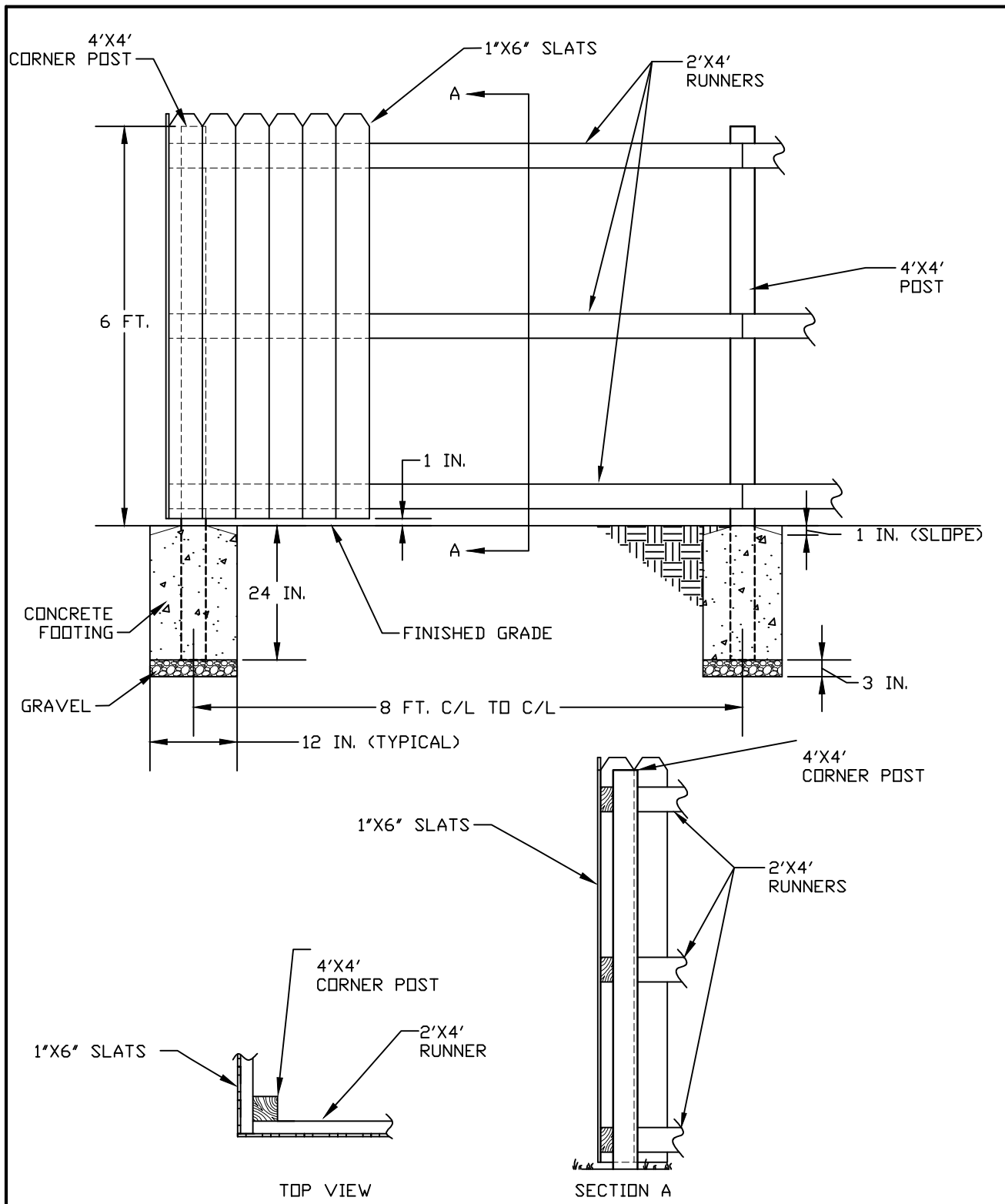

CLAYTON COUNTY WATER AUTHORITY

DATE:	12 AUGUST 2013	DETAIL TITLE:
SCALE:	N.T.S.	WOOD PRIVACY FENCE STOCKADE
DRAWN BY:	WWB	

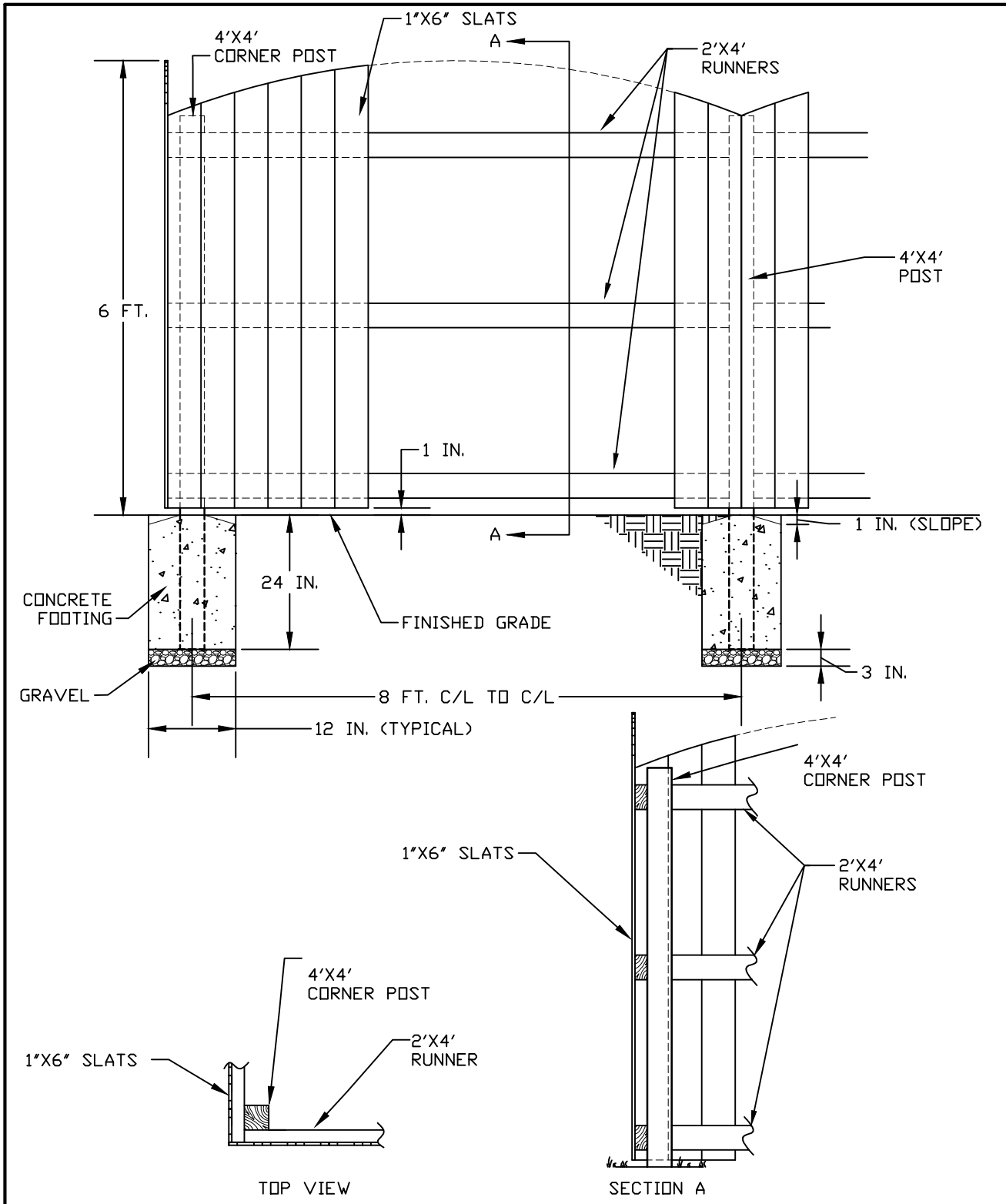

CLAYTON COUNTY WATER AUTHORITY

DATE:	12 AUGUST 2013	DETAIL TITLE:
SCALE:	N.T.S.	WOOD PRIVACY FENCE STOCKADE CURVED TOP
DRAWN BY:	WWB	

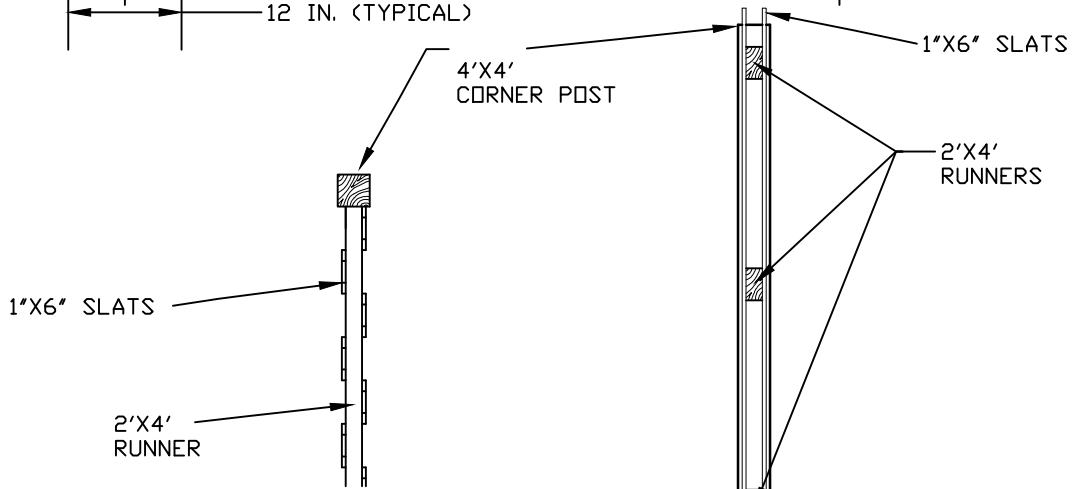
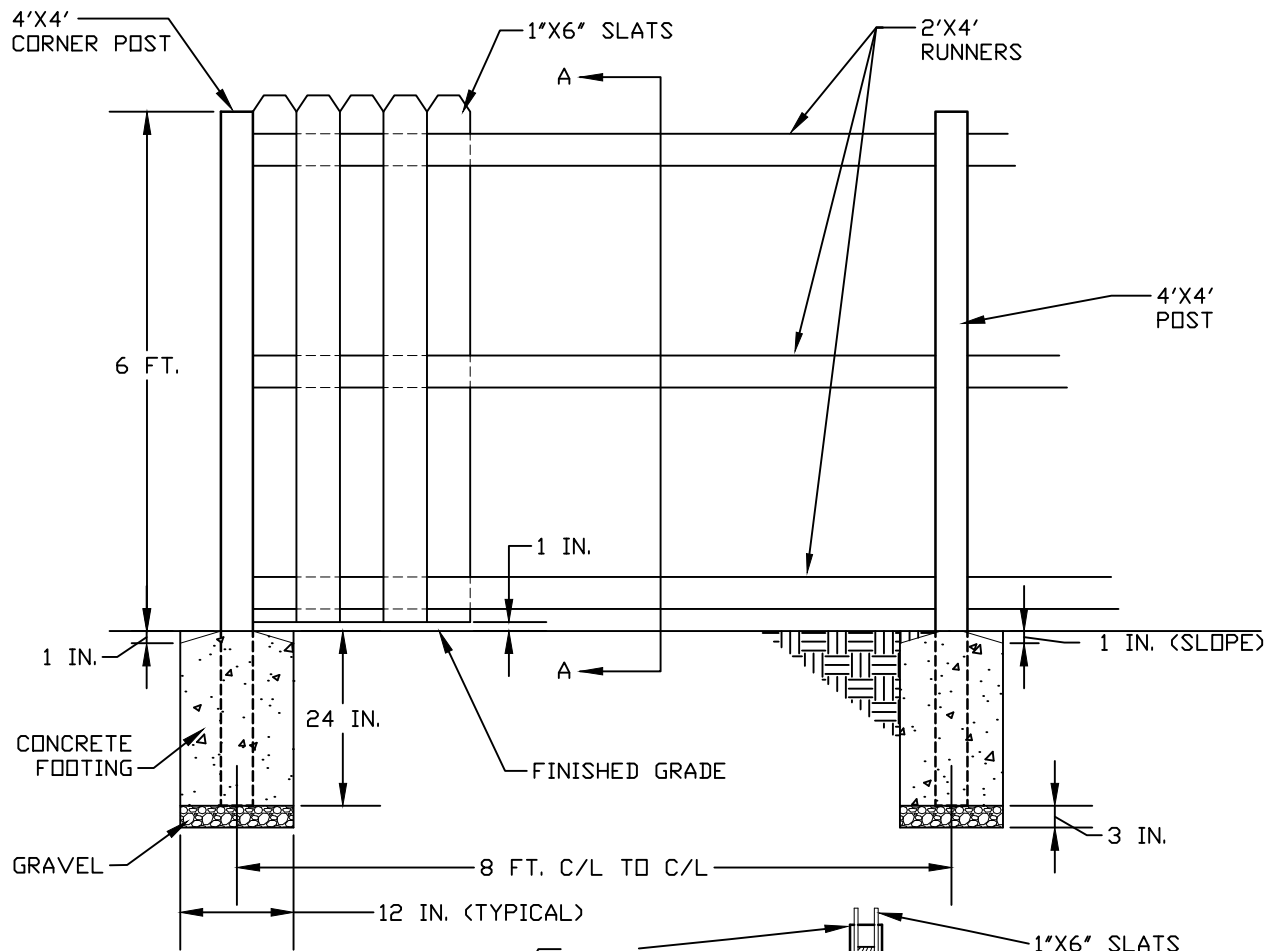

TOP VIEW

SECTION A

CLAYTON COUNTY WATER AUTHORITY

DATE:	12 AUGUST 2013
SCALE:	N.T.S.
DRAWN BY:	WWB

DETAIL TITLE:
WOOD PRIVACY FENCE SHADOW BOX