



INVITATION TO BID

GRAPPLE TRUCK WITH DUMP BODY

Issue Date: Wednesday, May 15, 2019

JONES COUNTY BOARD OF COMMISSIONERS

166 INDUSTRIAL BLVD./P.O. BOX 1359

GRAY, GA 31032

PHONE: (478) 986-6405

ATTN: JASON RIZNER, COUNTY ADMINISTRATOR

Jason.rizner@jonescountyga.org

PROPOSALS WILL BE RECEIVED UNTIL JUNE 12, 2019 AT 3:00 P.M.

BIDS ARE TO BE SEALED AND MAILED VIA USPS, FEDEX OR UPS TO THE ABOVE ADDRESS OR HAND DELIVERED TO THE COUNTY ADMINISTRATOR'S OFFICE LOCATED IN THE JONES COUNTY GOVERNMENT CENTER AT 166 INDUSTRIAL BLVD., GRAY, GA 31032. BIDS SHOULD BE SENT TO THE ATTENTION OF JASON RIZNER, COUNTY ADMINISTRATOR AND MARKED "BID - GRAPPLE TRUCK"



JONES COUNTY, GEORGIA
REQUEST FOR BIDS FOR THE PURCHASE OF ONE GRAPPLE TRUCK WITH A DUMP BODY

Jones County is requesting and will accept sealed bids for the purchase of one (1) new grapple truck with a dump body until Wednesday, June 12, 2019, at 3:00 p.m. local time, by Jason Rizner, County Administrator, at the Jones County Government Center, 166 Industrial Boulevard, Gray, GA 31032 at which time they shall be opened and read aloud. The bids submitted shall not be subject to public inspection until the contract is awarded.

Notwithstanding the foregoing, Jones County reserves the right to reject any or all bids and to waive technicalities and to select the bid that is in the best interest of Jones County.

MAILING INSTRUCTIONS

1. Bidder submit a complete, fully executed bid document.
2. If mailed, proposal should be forwarded by certified U.S. Postal Service. Please address and mark your bid as shown below.

JONES COUNTY BOARD OF COMMISSIONERS
ATTN: JASON RIZNER
P.O. BOX 1359
166 INDUSTRIAL BLVD.
GRAY, GA 31032
“BID – GRAPPLE TRUCK”

3. If forwarded other than by U.S. Postal Service, delivery must be made directly to Jones County Administrator Jason Rizner, Jones County Government Center, 166 Industrial Blvd., Gray, GA 31032.

NOTE: IF MAIL OR DELIVERY BY ANY OTHER MEANS IS DELAYED BEYOND THE DATE AND HOUR SET FOR BID OPENING, THE BID THUS DELAYED WILL NOT BE CONSIDERED.



General Information

The Jones County Board of Commissioners is accepting bids for the purchase of one new grapple truck with a dump body. This truck will be used by the Jones County Public Works Department, and its primary uses will be removing trash from county convenience centers and hauling trash to the landfill. This bid is requesting quotes for trucks equipped with a grapple arm. The grapple arm shall be long enough to reach over into – and to the bottom of – a roll-off canister that the truck would be parked alongside.

The truck proposed by vendors shall be new and from the most current model year.

Specifications

Trucks quoted by prospective vendors should meet the following minimum specifications:

- Mack Granite Tandem Axle Truck
 - MP7-355A, 1280 lb. ft. Automatic
 - Automatic Allison RDS Transmission
 - Swept Back Bumper, Two Tow Hooks with Radiator Guard
 - Single Left and Right Horns
 - Mack Camelback Suspension
 - Double Frame Chassis
 - Outriggers
 - Standard Interior Trim
 - Vinyl Seats
 - Vinyl Flooring
 - AM/FM Radio
 - Dust Cover for Driver's Seat
 - Air Conditioning
 - Power Steering
 - Power Windows
 - Power Door Locks
 - Exterior Color – White
 - Power Divider Lockout with Buzzer and Light
 - Front Axle – 20,000#
 - Front Axle Brakes – “S” Cam Type
 - Tandem Rear Axles – 46,000#
 - Rear Axle Ratio – 4.50
 - Rear Suspension – Mack AL-461 AIR 46,000#
 - Heated Exterior Mirrors with Integral Convex Mirror
 - Exterior Sun Visor
 - Front Tires – 425/65R22.5
 - Rear Tires – 11R22.5
 - Roof Marker Lights (5)

- 60 Yard Heavy Duty Dump Body
 - Single Door – Swing Open Passenger Side



- Paint Color – Black
- Side Material: 3/16” AR400
- Floor Material: 3/16” AR400

- Grapple Arm/Loader (see attached illustration) – (Rotobec 910 or similar)
 - Spread should be no less than 80”
 - Claws should be a minimum of 60” in width
 - Telescopic Boom
 - Operator Railing
 - Mounted Back of Cab

- Accessories/Other
 - Outrigger Pad Holder
 - Safety Cone Holder
 - Wheel Chock Holder
 - Aluminum Hydraulic Tank
 - 1 Tool Box Under Bed – Driver’s Side
 - 2 Tool Boxes Under Bed – Passenger Side

Vendors should submit complete specifications on the vehicle that are proposing covering both the items listed above and any other features that the vehicle may have.

We understand that dimensions and the like vary from one manufacturer to another. If your company does not offer a grapple arm with the exact dimensions specified in this document, we encourage you to submit a bid with a comparable grapple.

Please include any delivery charges and other dealer charges in the total price on the bid form. The total price should be an “out the door” price.

Vendors should also submit detailed warranty information on the vehicle and the grapple arm.

Vendors must provide affidavit verifying status for County Public Benefits and Contractors E-Verify Affidavit with the submittal of the bid as applicable (see attached).

Terms and Conditions

- The County reserves the right to reject and or all bids or proposals, to waive technicalities, and to make a selection and final award as deemed to be in the best interest of the County.

- Provider selection will be based on the information contained in the bids, and incomplete or inaccurate information may result in disqualification of a proposal or a bidder.

- The Jones County Board of Commissioners reserves the right to accept or reject any or all bids, to solicit additional bids, or to amend or revise bid documents.



- The proposal submitted by each proposed service provider will be treated as best and final. There will be no opportunity to negotiate fees during the selection process.
- The County does not guarantee the purchase of any/all equipment.
- The County reserves the right to terminate any contract for this equipment and/or services for any of the following reasons:
 - a. If the equipment/service is not delivered/completed on an agreed-upon schedule.
 - b. If the equipment/services delivered is not the same equipment/services bid.
 - c. Receipt of substandard product/service.
 - d. Poor workmanship.



Bid Form

Checklist

- Vehicle complies with specifications in this document**
- Warranty information included**
- E-Verify Affidavit attached**
- Application for Public Benefit attached**

I further understand that I will be required to submit the attached Prime and Subcontractor's Work Authorization Certification and affidavit verifying status for County Public Benefit Application (copy attached), prior to beginning work.

I certify that the bid(s) below meets all specifications outlined in the bid documents:

Company: _____

Address: _____

Contact: _____ E-mail Address: _____

Phone: _____ Fax: _____

Signature of Company Official: _____

(The remainder of this page intentionally left blank . . . Bid Form continued on next two pages)



Bid Form (Continued)

Specification	Specification Met?	Notations if Necessary
Mack Granite Tandem Axle Truck		
MP7-355A, 1280 lb. ft. Automatic		
Automatic Allison RDS Transmission		
Swept Back Bumper, Two Tow Hooks with Radiator Guard		
Single Left and Right Horns		
Mack Camelback Suspension		
Double Frame Chassis		
Outriggers		
Standard Interior Trim		
Vinyl Seats		
Vinyl Flooring		
AM/FM Radio		
Dust Cover for Driver's Seat		
Air Conditioning		
Power Steering		
Power Windows		
Power Door Locks		
Exterior Color – White		
Power Divider Lockout with Buzzer and Light		
Front Axle – 20,000#		
Front Axle Brakes – “S” Cam Type		
Tandem Rear Axles – 46,000#		
Rear Axle Ratio – 4.50		
Rear Suspension – Mack AL-461 AIR 46,000#		
Heated Exterior Mirrors with Integral Convex Mirror		
Exterior Sun Visor		
Front Tires – 425/65R22.5		
Rear Tires – 11R22.5		
Roof Marker Lights (5)		
60 Yard Heavy Duty Dump Body		
Single Door – Swing Open Passenger Side		
Paint Color – Black		
Side Material: 3/16” AR400		
Floor Material: 3/16” AR400		



Specification	Specification Met?	Notations if Necessary
Grapple Arm/Loader (see attached illustration) – (Rotobec 910 or similar)		
Spread should be no less than 80”		
Claws should be a minimum of 60” in width		
Telescopic Boom		
Operator Railing		
Mounted Back of Cab		
Accessories/Other		
Outrigger Pad Holder		
Safety Cone Holder		
Wheel Chock Holder		
Aluminum Hydraulic Tank		
1 Tool Box Under Bed – Driver’s Side		
2 Tool Boxes Under Bed – Passenger Side		

Vehicle Year: _____

Vehicle Make: _____

Vehicle Model: _____

Grapple Year: _____

Grapple Make: _____

Grapple Model: _____

Notes: _____

Total Price: _____



Affidavit Verifying Status County Public Benefit Application Jones County Board of Commissioners

By executing this affidavit under oath, as an applicant for a Jones County Georgia Business Occupation Tax Certificate, Alcohol License, Taxi Permit or other public benefit as referenced in O.C.G.A. Section 50-36-1, I am stating the following with respect to my application for a Jones County Business Occupation Tax Certificate, Alcohol License, Taxi Permit or other public benefit for _____. [Name of natural person applying on behalf of individual, business, corporation, partnership, or other private entity]

1) _____ I am a United States citizen

OR

2) _____ I am a legal permanent resident 18 years of age or older or I am an otherwise qualified alien or non-immigrant under the Federal Immigration and Nationality Act 18 years of age or older and lawfully present in the United States.*

In making the above representation under oath, I understand that any person who knowingly and willfully makes a false, fictitious, or fraudulent statement or representation in an affidavit shall be guilty of a violation of Code Section 16-10-20 of the Official Code of Georgia.

Signature of Applicant: _____

Date _____

Printed Name: _____

SUBSCRIBED AND SWORN
BEFORE ME ON THIS THE

____ DAY OF _____, 20__

*

_____ Alien Registration number for non-citizens

Notary Public _____

My Commission Expires: _____

***Note:** O.C.G.A. § 50-36-1(e)(2) requires that aliens under the federal Immigration and Nationality Act, Title 8 U.S.C., as amended, provide their alien registration number. Because legal permanent residents are included in the federal definition of "alien", legal permanent residents must also provide their alien registration number. Qualified aliens that do not have an alien registration number may supply another identifying number below:



Exhibit 1

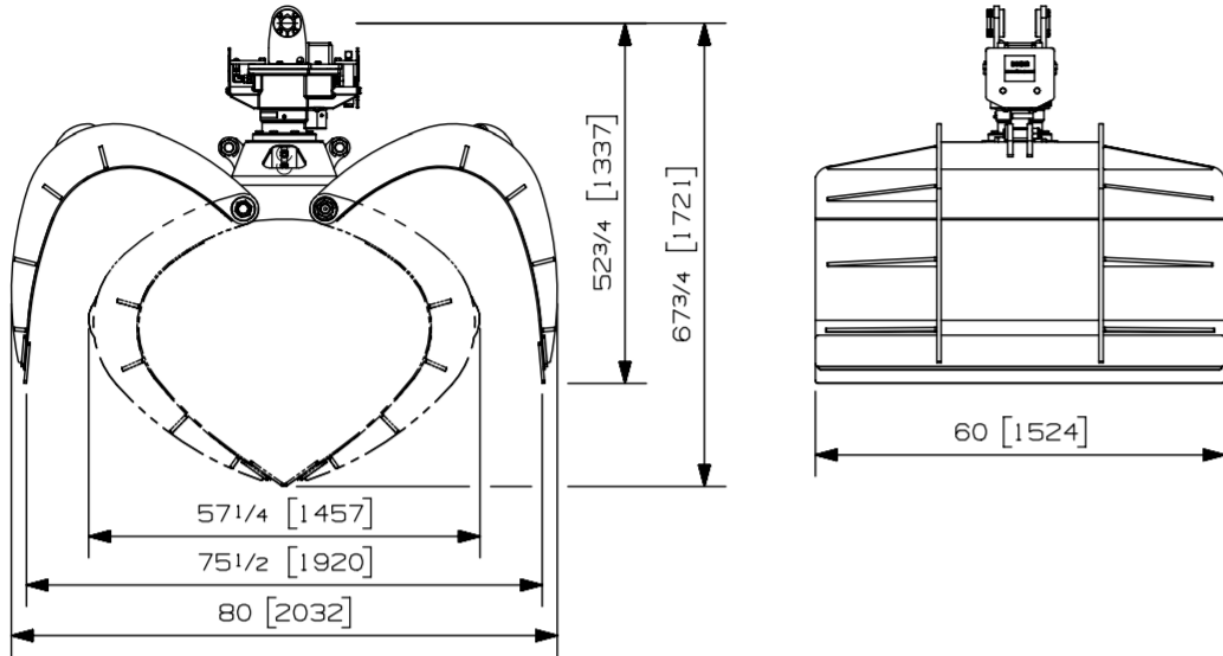

- Grapple dimensions should be similar to those depicted in the images above. In the event that a prospective bidder does not have a grapple of similar dimensions, they are encouraged to submit a bid with equipment similar to that depicted above.



OPTIONAL — FOR NON-BIDDERS ONLY

**JONES COUNTY BOARD OF COMMISSIONERS – PURCHASING DEPARTMENT
NO BID STATEMENT**

In an effort to make the procurement of goods and services for the County as competitive as possible, we are soliciting information from contractors and/or vendors who cannot bid. Your responsiveness and constructive comments will be appreciated. Completion of this form will assist us in evaluating factors which relate to the competitiveness of our bids. Please check any of the boxes below which may apply. Please explain any issues that you feel needs to be addressed.

- Specifications - Restrictive, too light", unclear, specialty item, geared toward one (1) brand or manufacturer only. *(Please explain in detail below).*
- Manufacturing - Unique item, production time for model has expired, etc.
- Bid Time - Insufficient time to properly respond to bid or proposal.
- Delivery Time - Specified delivery time cannot be met.
- Payment - Payment terms unacceptable. *(Please be specific)*
- Bonding - We are unable to meet bonding requirements.
- Insurance - We are unable to meet insurance requirements.
- Removal - Remove our firm from your bidders list for the particular commodity or service.
- Keep - Please keep our company on your bidders list for future reference.
- Project is: _____ / Too Large _____ / Too Small _____ / Site or Location is Too Distant
- Miscellaneous - Do not wish to bid, do not handle this type of item(s) or services, unable to compete, Contract clauses are unacceptable, etc. *(Please be specific)*
- Our company would only be interested in this project as a subcontractor or supplier.

VENDOR STATEMENT:

Bid #: _____

Bid Description: _____

Company Name: _____

Company Official Name: _____

Company Official Signature: _____

Telephone Number: _____

Email Address: _____

**JONES COUNTY BOARD OF COMMISSIONERS – PURCHASING DEPARTMENT
(478) 986-6405 x 161
leslie.faulk@jonescountyga.org**