

Discharge Flange Kit - For Floor Elbow

Includes - Flange, Gasket and Hardware
Weil = 2 bolt oval configuration

Order Number	Pipe Type	Flange Type
2613K204	Plain End	Weil
2613K104	Threaded	Weil
2613K106	Threaded	ANSI

Intermediate Guide Pipe Bracket:

205.666.001	Intermediate Guide Pipe Bracket
-------------	---------------------------------

System Includes:

- Discharge Floor Elbow - one
- Sliding Bracket - one
- Iron or Bronze for use with Explosion Proof Motor
- Guide Pipe Bracket - one
 - Ⓐ - Flat (cover mount) - bolts to wet well cover or
 - Ⓑ - Angle 90° (side mount) - bolts to vertical side wall or
 - Ⓒ - BCB Bracket - Duplex or Simplex mounts to discharge pipe(s) - see pg 2 diagrams

Not Included:

- Discharge Pipe, Guide Pipe - 2 inch schedule 40 & Flange Kit

Options:

- Discharge Flange Kit for Floor Elbow
- Intermediate Guide Pipe Bracket
- Sub Base for Floor Elbow
- Level Control Lifting Assembly for BCB Duplex Bracket

Removal System:

Simplex				
Order Number	Sliding Bracket	Guide Pipe Bracket	Mount Type	Wt Lbs
2613K1023	Iron	Flat	Cover	138
2613K5011	Iron	Angle	Side	138
2613K2023	Bronze	Flat	Cover	138
2613K6034	Bronze	Angle	Side	138
2613K3023	Iron	BCB	Pipe	138
2613K4023	Bronze	BCB	Pipe	138
Duplex - BCB System				
Order Number	Sliding Bracket	Guide Pipe Bracket	Mount Type	Wt Lbs
2613K7023	Iron	BCB	Pipe	276
2613K7033	Bronze	BCB	Pipe	276

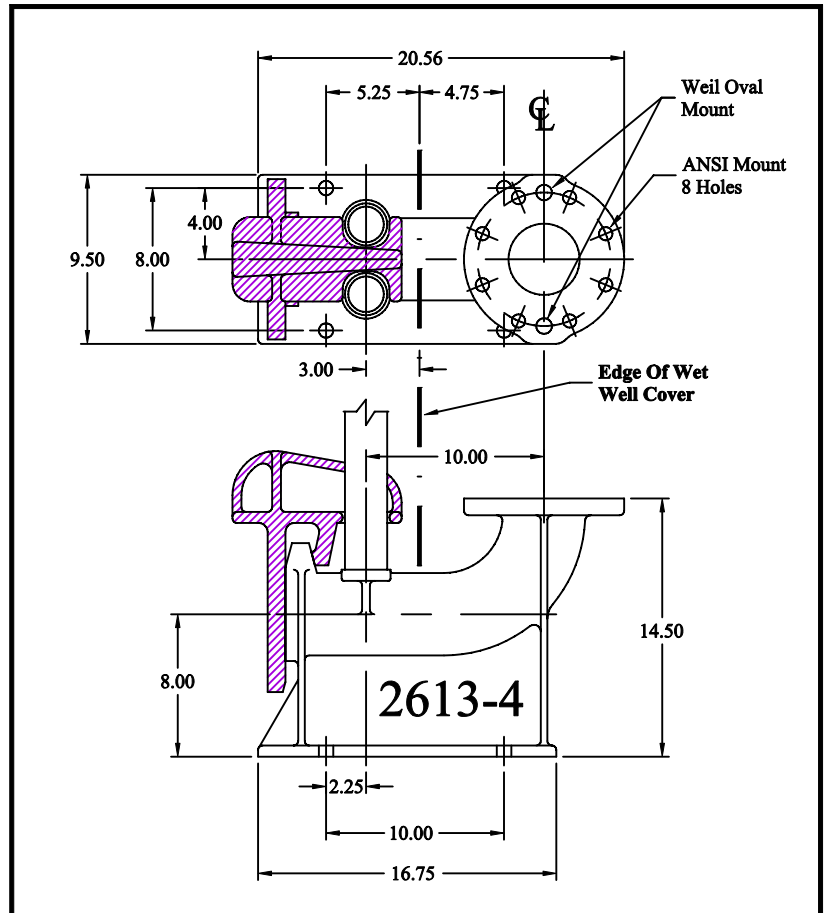

BCB - Simplex

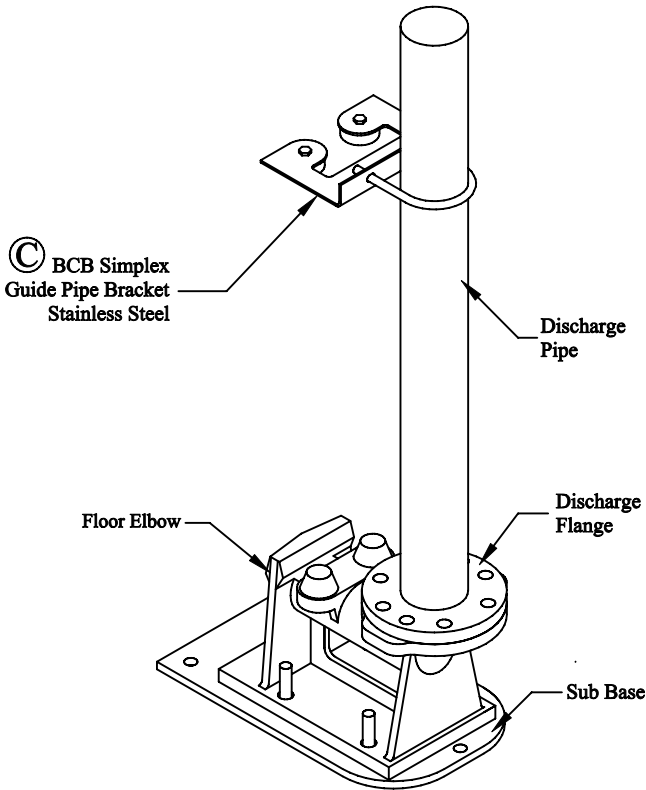

BCB - Duplex

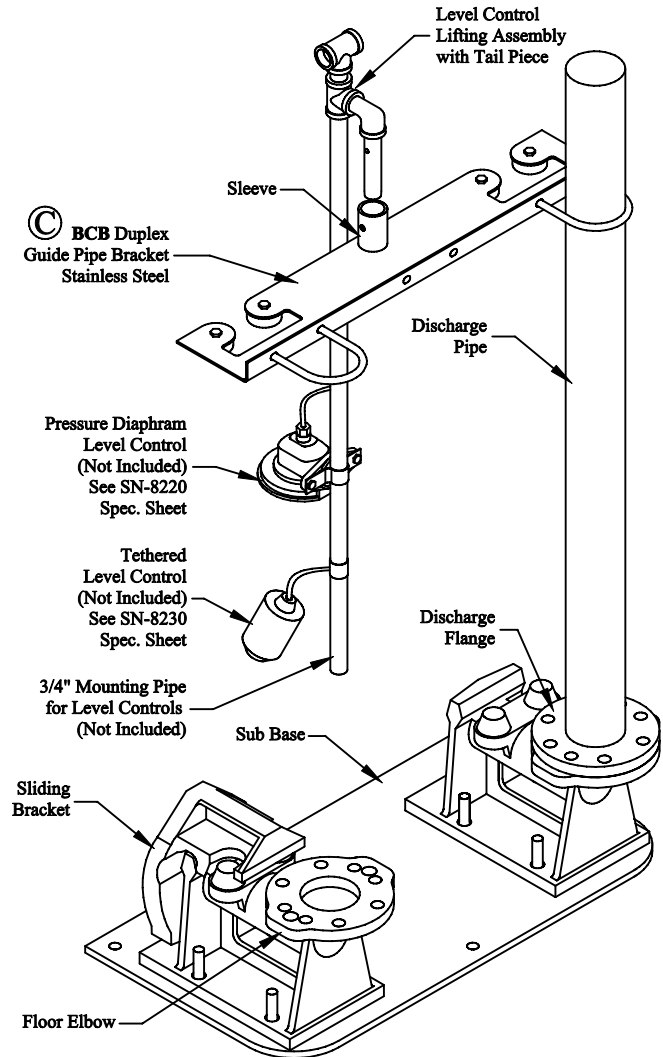

Sub-Base - SIMPLEX

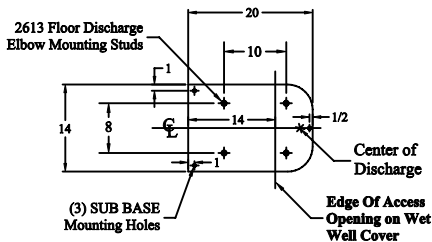

Sub-Base - DUPLEX

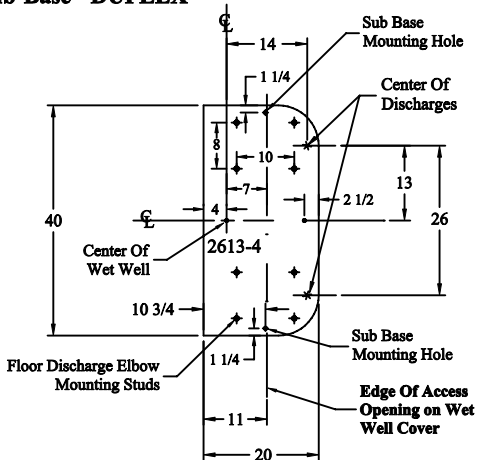

Sub Base for Simplex/Duplex Installations

Steel galvanized sub base with stainless steel studs is used to locate and install the 2613 discharge floor elbows in a wet well. Mounting locations match standard Weil 8804/8815 wet well covers. Three 9/16 holes for bolting to the wet well floor. Waterproof adhesive 3M Marine 5200 could be used instead of bolting.

Order Number	Style	Stud Size	Pump Size	Min. Wet Well Diameter
2613K604	Simplex	5/8"	7" case	30"
			9" case	42"
			12" case	48"
2613K503	Duplex	5/8"	7" case	48"
			9" case	54"
			12" case	60"

Level Control Lifting Assembly

(Duplex BCB systems only)

Does not include level control switches or mounting pipe. See SN-8220 and SN-8230

Order Number	Description
2613K801	Level Control Lifting Assembly with Tailpiece

The 8234 switch is required when intrinsically safe relays are used for pump control or high water alarm circuits. Switches are rated 1 amp.

An intrinsically safe circuit operates at a low DC voltage and current - typically 9-volts, 10 milliamps. A small amount of oxidation on the switch contacts can cause unreliable circuit operation.

The contacts in the hermetically sealed mercury switch compartment or the gold plated contacts of the 8234 float switch remain corrosion free. This insures trouble free operation.

Each tethered switch includes a cord grip and strap mount for mounting to a 3/4 inch or 1 inch diameter pipe.

8234 Single Pole

Gold Plated Contact Mechanical Switch

Order Number	Cord Length (Ft.)	Approx. Wt. (Lbs.)
8234K1004G	20	4
8234K1006G	40	6
8234K1008G	60	8
8234K1010G	80	10

2 wire cord - Black/White

8234 Single Pole

Mercury Switch

Order Number	Cord Length (Ft.)	Approx. Wt. (Lbs.)
8234K1004M	20	4
8234K1006M	40	6
8234K1008M	60	8

2 wire cord - Black/White

8234 Double Pole

Mercury Switch

Order Number	Cord Length (Ft.)	Approx. Wt. (Lbs.)
8234K2002	20	4
8234K2004	40	6

4 wire cord - Black/White and Red/Blue

Mounting Bracket

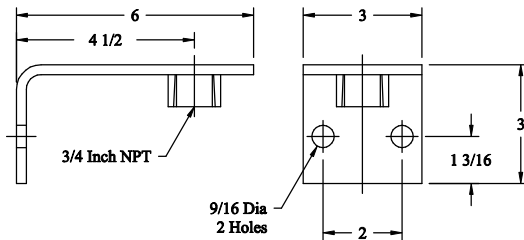

Mounting Plate

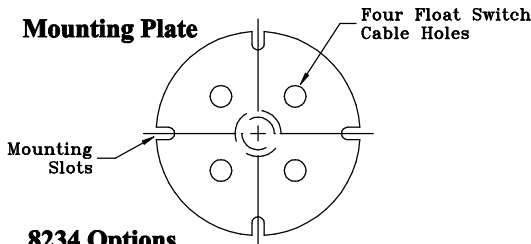

8234 Options

Option	Description
314.399.000	Mounting Bracket - For sidewall, suspends 3/4 inch pipe from wet well wall. Pipe Not included.
315.445.001	Mounting Plate - Round 8-inch diameter with four holes for level control cable cord grips. Suspends 3/4 or 1 inch pipe from mounting plate. Pipe not included. Fastens to wet well cover with fasteners.
304.331.096	Mounting Pipe - 3/4 inch schedule 40, 10 feet long. Threaded on one end. For mechanical switches.
303.935.103	Mounting Pipe - 1 inch schedule 40, 10 feet long. Threaded on one end. For mercury switches.

Simplex Configuration

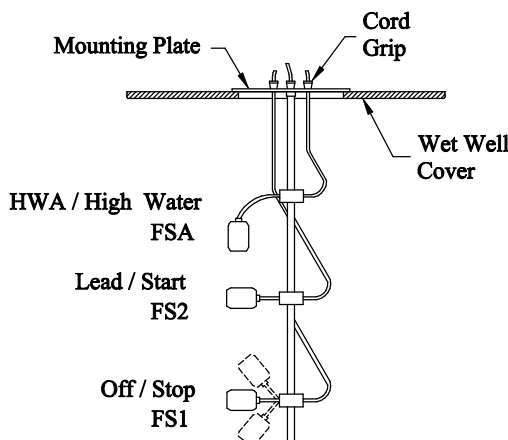

Duplex Configuration

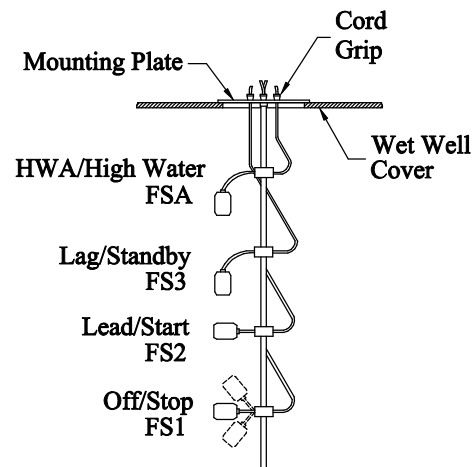

How to order: Specify Order Number, Wet Well Depth and Options.
F. O. B. Cedarburg (Milwaukee), Wisconsin

WEIL Duplex Alternating Pump Control Panel

8165

Duplex

Intrinsically Safe Relay Meets U/L 698A
Type 4 Double Door Dead Front Enclosure

- The 8165 is a full featured duplex panel that controls two pumps with U/L explosion-proof motors.
- Panel can be operated on 50 or 60 Hertz power.
- Requires model 8234 single-pole level switches - three for level control and one for high water alarm.
- Type 4 enclosure for indoor or outdoor use. Provides a degree of protection against falling rain, splashing water and hose-directed water; undamaged by the formation of ice on the enclosure.
- Exceeds Type 1, 3R and 12 requirements.

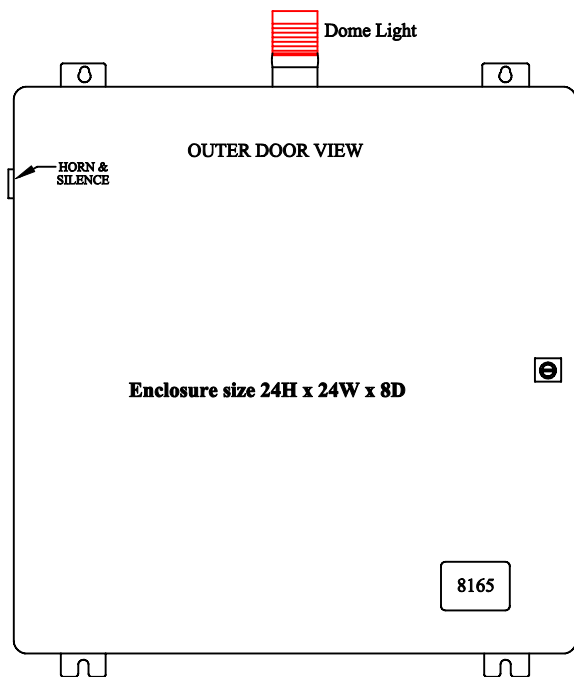

Control Panel Selection Guide

- Determine Phase and Voltage
- Determine maximum run current in amps required by the pump motor.

Panel Includes

- U/L Listed Label - meets U/L 698A
- LED Lights, hour meter, switches, and test buttons are mounted on inner door.
- One lockable panel disconnect; through-the-door with door interlock on inner door. The mechanical interlock prevents the door from being opened when the disconnect is in the ON position. Lock is not provided.
- Padlocking hasp - on outer door, padlock not included.
- Two lockable pump disconnects, on motor overload protectors. Lock is not provided.
- Electric ISR Alternator with three position pump selector switch.
- Two Contactors-Industrial Duty.
- Two Overloads - one per pump. Ambient compensated bi-metallic (Class 10) motor overload circuit protector. instantaneous magnetic trip for short circuit protection. Single-phase protection for three-phase motors. Field adjustable within the Amp range.
- Control transformer with fused primary and secondary, for three-phase and single-phase 208 and 230-volt supply. Single-phase 115-volt has a fused control circuit.
- Pump run switches - one per pump. Three position TOA (test-off-automatic) with spring return to off from test.
- Green lights (2) indicates power to pump motors.
- White light indicates control power on.
- Red overload lights (2) indicates motor overload condition and pump is off. Light remains on and pump remains off until reset.
- Hour meters (2). Non resetting meter indicates total pump run time.
- Moisture sensor relay and pump shut down circuit mounted inside enclosure. Yellow lights indicate moisture in pump motor. Includes moisture sensor test button.
- Temperature limiter circuit shuts down pump motor when motor over temperature is sensed. The temperature limiter circuit automatically resets when the motor temperature falls to a normal operating range. Blue light indicates there is a motor over temperature.
- Intrinsically safe relay and intrinsically safe circuit for 4 level control switches.
- General Alarm Fault and Pump Run Status isolated contacts.
- High Water Alarm System Type 4x. Hold finger over hole of horn for 1-2 seconds and remove to silence horn (95 dB).
 - Red HWA light and alarm test button on inner door.
 - Two isolated contacts for remote monitoring and/or to use as a connection to a phone dialer.
- Alarm LED Dome Light - Lexan, red flashing on top of enclosure. Light indicates a general fault condition; overload, high water, moisture sensor or over temp condition. Light remains on until condition is corrected.
- Control Terminal board, numbered and wired.
- Layout and schematic CAD diagrams are provided. Installer connections at terminal board are clearly marked.

Motor Protector Amp Range	Order Number			Approx. Weight Lbs.
	Single-Phase 115 Volts	Single-phase 208 or 230 Volts	Three-Phase 208, 230,460 Volts	
1.0 - 1.6	8165-L-016	8165-D-016	8165-T-016	80
1.6 - 2.5	8165-L-025	8165-D-025	8165-T-025	80
2.5 - 4.0	8165-L-040	8165-D-040	8165-T-040	80
4.0 - 6.3	8165-L-063	8165-D-063	8165-T-063	80
6.3 - 10.0	8165-L-100	8165-D-100	8165-T-100	80
10.0 - 16.0	8165-L-160	8165-D-160	8165-T-160	81
16.0 - 20.0	8165-L-200	8165-D-200	8165-T-200	83
20.0 - 25.0	8165-L-250	8165-D-250	8165-T-250	83
*25.0 - 32.0	8165-L-320	8165-D-320	8165-T-320	96
*32.0 - 40.0	8165-L-400	8165-D-400	8165-T-400	96
*40.0 - 50.0	8165-L-500	8165-D-500	8165-T-500	106

*Includes 2nd disconnect switch and larger enclosure

OPTIONS:

8100K7079 Type 4X 304 Stainless Steel outer enclosure

How to Order: Specify the Order Number, System Phase and Voltage, and Pump Motor HP.

F.O.B. Cedarburg (Milwaukee), Wisconsin

X

Replaces SN-8165, July 1, 2008

SN-8165

MARCH 1, 2017

8165

Intrinsically Safe Relay Meets U/L 698A
Type 4 Double Door Dead Front Enclosure

Duplex

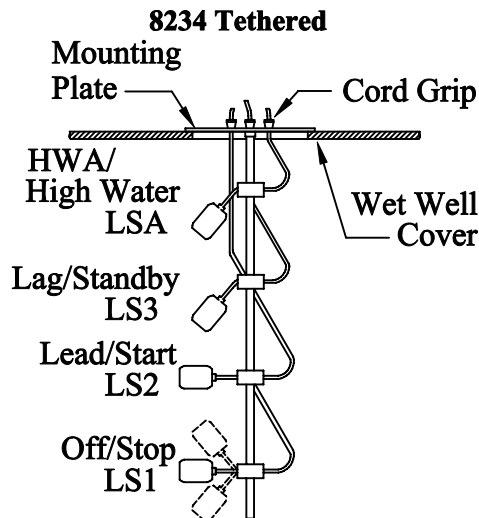
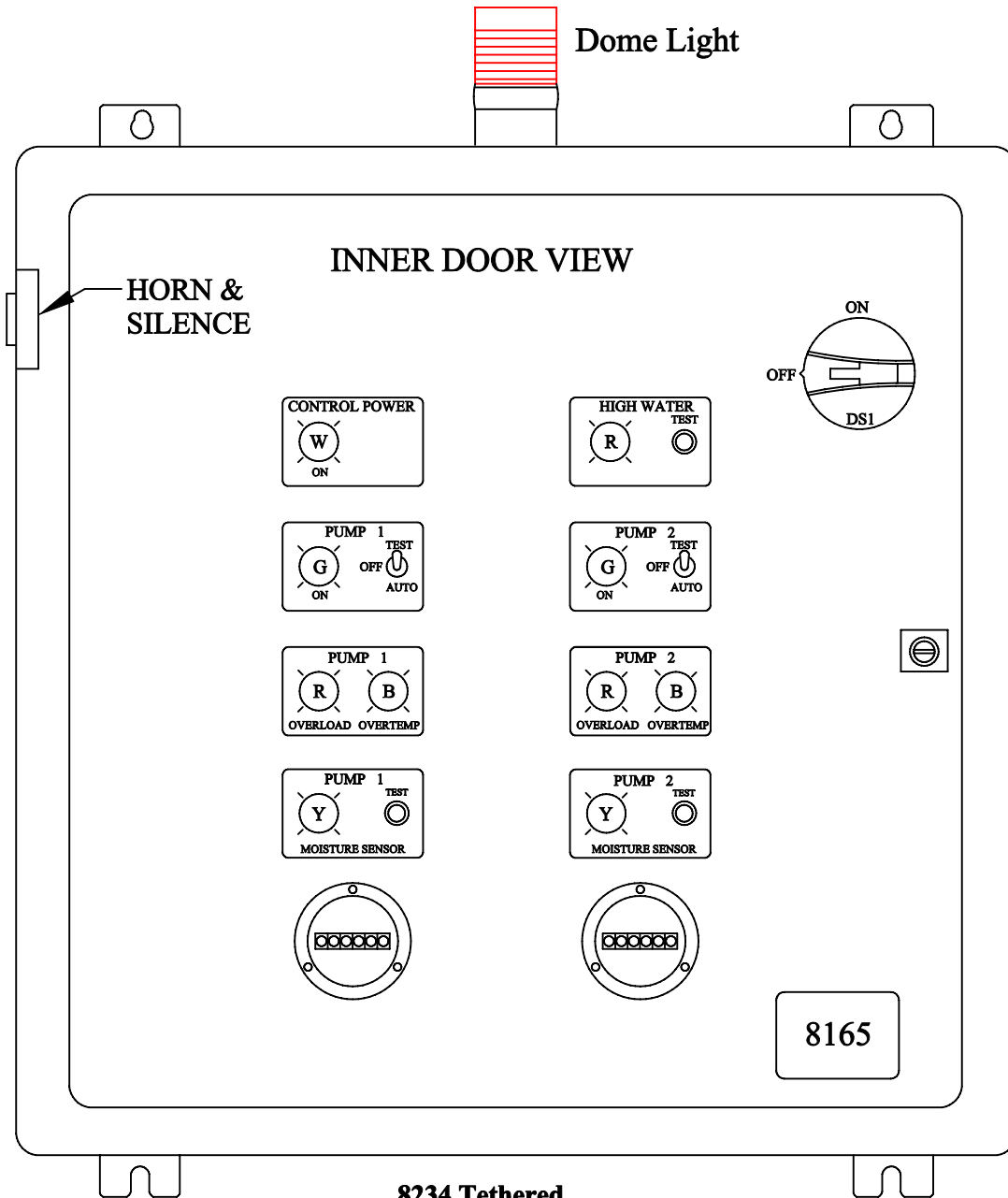



Heavy duty pump for commercial and industrial applications.
Pump clear water, gray water, effluent and wastewater with solids up to 3-inch diameter.

Disch. Size 4 Inch
Disch. Type ANSI
Solids Max. 3 Inch
Mounting Style 2613 Removal

Pump

- Case - Cast Iron
- Impeller - Cast Iron
- Stainless Steel Hardware

Motor

- Double Seal - Tandem**
 - Upper - Carbon against Ceramic
 - Lower - Silicon Carbide against Silicon Carbide
- Air-Filled Hermetically Sealed Shaft - Stainless Steel Series 300**
- Motor Shell - Cast Iron
- Insulation - Class F
- Ball Bearings - 2 - Double Sealed
- Power Cable Length - 25 ft
- Three-phase motor
 - 1150 and 1750 RPM
 - 60 Hz, 208-230 or 460 volts

Options

- Bronze Impeller
- CUL/UL Explosion Proof Motor
- 575 Volt 60 Hz 3 Phase Motor
- Moisture Sensor and Temperature Limiter
- Additional Power Cable Lengths
- Stainless Steel Lifting Cable

Capacities - Wet Wells		
Dia or Side Inches	Gallons per Foot of Depth	
	Round	Square
48	94	120
60	147	187
72	212	269

Flow - To prevent solids from settling out	
Discharge Pipe Size Dia Inches	Minimum Flow GPM
3	50
4	90
6	200

Good wet well design
Maximum 10 starts per hour.
Minimum run time - 1 1/2 minutes.

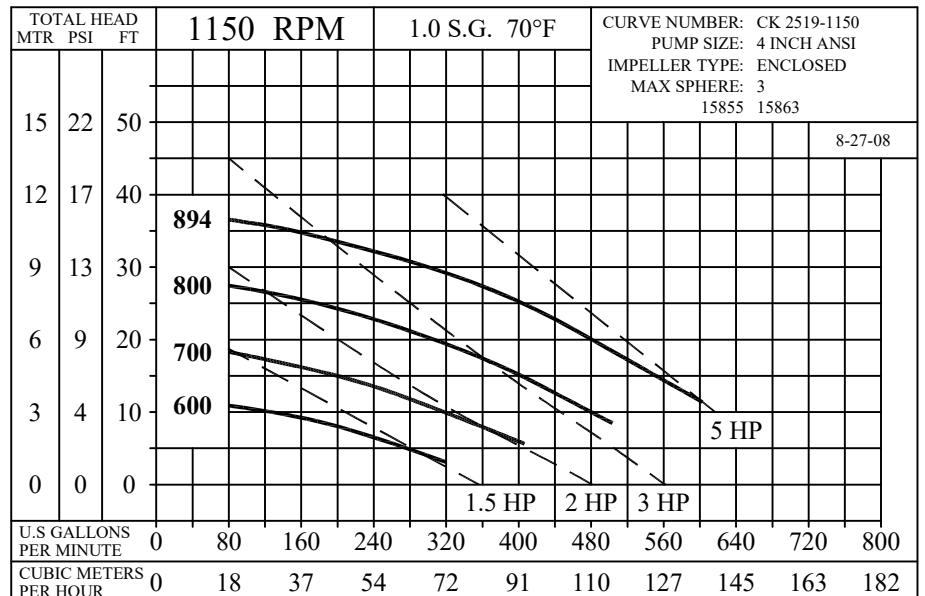
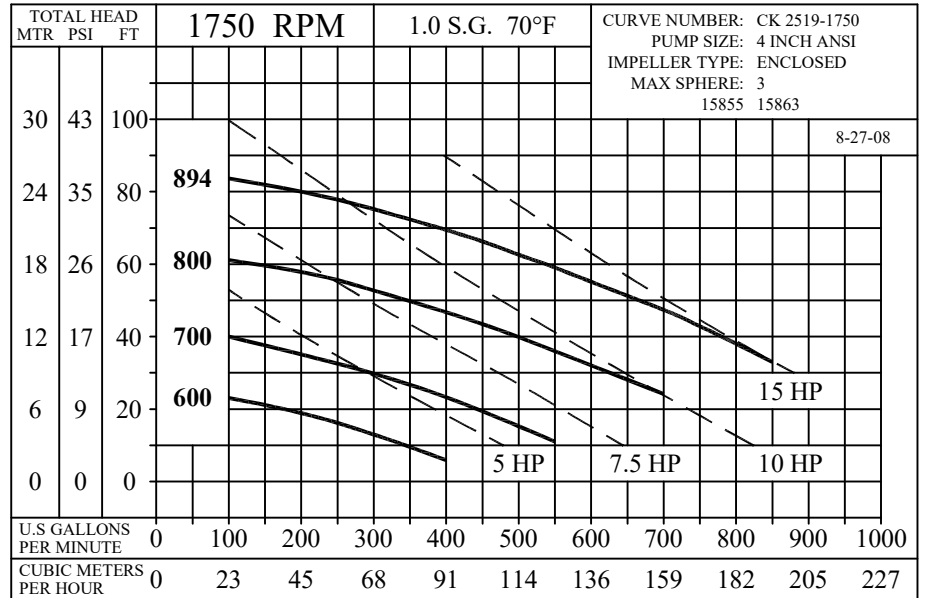
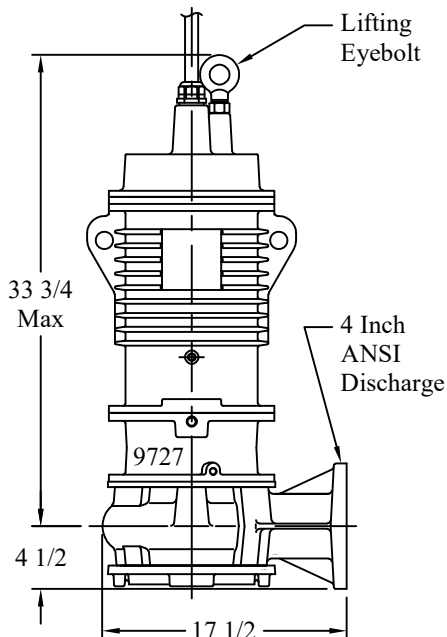
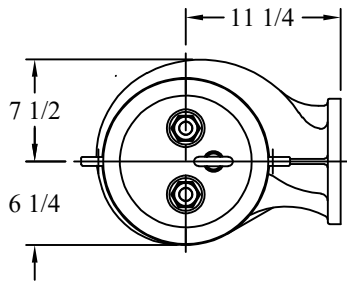

SN-2519-A-2



Replaces SN-2519, July 1, 2015

SN-2519

JANUARY 1, 2019