



THIS FORM MUST BE COMPLETED, SIGNED AND NOTARIZED TO BE CONSIDERED VALID.

Address To: Kristinia Davis
 Sullivan County Purchasing Department
 3411 Hwy 126, Ste 201
 Blountville, TN 37617-0569

Phone: (423)323-6400 FAX: (423)323-7249
 Email: kris.davis@sullivancountyttn.gov

Date Issued: 02/28/2022

Bid/Quote Number:
022422(KD)

F.O.B.: Blountville

Total Number of Pages: 88

This Invitation to Bid/Quote, subject in the original copy, subject to the terms and conditions on the attachment, will be received by the Purchasing Agent until **2:00 P.M., EST on Thursday, March 31, 2022.**

In the lower left corner of your envelope addressed to the above, mark your envelope **“Four (4) Type I (4x4) Ambulances”**

Bid/Quote Documentation can be found on-line at:

<https://vrapp.vendorregistry.com/Bids/View/BidsList?BuyerID=37b55d57-2b40-462f-bd8e-5b80ab095ddd>

****Funding for this bid is provided by the American Rescue Plan Act (ARPA). All entities submitting a bid must be registered in the SAM.gov website to be considered for award.** This Bid Form, Terms & Conditions (Section 28) and all ambulance specifications must be completed and signed.**

Format Accepted: () Online Bid/Quote Only () Hard Copy Bid/Quote Only () Online or Hard Copy

READ THE TERMS AND CONDITIONS BEFORE COMPLETING THIS FORM

Item	Qty	U/l	Description	Unit Price	Total Price
1	4	ea.	<p>This Invitation to Bid is for four (4), Type I (4 x 4) Ambulances, as per the attached, for the Sullivan County EMS Department to be bid as specified.</p> <p>***See Additional Equipment requested on pages 9-13. A separate cost sheet may be included if needed.</p> <p>Delivery Terms: 1.Per the ARPA Grant Delivery must be made no later than 12/31/2024. Please state estimated delivery time: _____</p>		

In compliance with this invitation and subject to all conditions thereof, the undersigned agrees, if this Bid/Quote is accepted within 30 days from the date of the opening, to furnish all of the materials/services upon which prices are proposed, delivered at the designated point(s) within the time specified.

Sullivan County reserves the right to award on a "line item" basis or "all or none" basis, whichever is most advantageous. Sullivan County also reserves the right to award contracts or portions thereof exclusively or to multiple vendors to achieve the best value. Sullivan County reserves the right to reject any and/or all bids.

Terms: NET 30

Signature of Authorized Representative

Printed Name of Authorized Representative

Name of Firm

Date

Email Address

Subscribed and sworn to before me this
_____ day of _____, 20____,

Notary Public

My Commission Expires: _____

THIS FORM MUST BE SIGNED AND NOTARIZED TO BE CONSIDERED COMPLETE

GENERAL TERMS AND CONDITIONS

1. SUBMITTAL REQUIREMENTS

Submittals for consideration must be submitted on the form provided and bear the handwritten signature of an authorized representative of the firm and notarized to be considered valid. If submitting multiple bids/ proposals in paper form, each must be placed in a separate envelope. Be sure the envelope is completely and properly identified and sealed. Bids/ RFP's/ RFQ's will be read aloud at the specific date and time as stated in the invitation. RFP/RFQs respondent's names only will be read aloud.

All openings are public meetings. Bidders/ proposers and interested persons are invited to attend. The County reserves the right to postpone any solicitation opening under circumstances warranting such action, including but not limited to instances when the County receives fewer than two responses.

Unless otherwise stated by the County, no bidder may withdraw a bid within a period of sixty (60) days after the date set for the opening of bids. Bids and modifications or corrections thereof received after the closing time specified will not be considered. The County is not responsible for delays in delivery by mail, courier, etc.

Any exceptions to these terms and conditions or deviations from written specifications will be shown in writing and attached to the bid form. Any alteration, erasure, addition to or omission of requested information, change of the specifications, or bidding schedule, is made at the risk of the bidder and may result in the rejection of the bid, unless such changes are authorized by the specifications.

2. QUESTIONS / ADDENDA

Failure to examine any drawings, specifications, and instructions will be a bidder's risk. If bidder is in doubt as to the true meaning of any part of the drawings, specifications and instructions or other documents, he should submit a written request for an interpretation to the Purchasing Agent. An interpretation of the documents will be made only by addendum and issued by the Purchasing Agent. The County will not be responsible for explanation or interpretations of bid documents except as issued in accordance herewith.

Where a brand or trade name appears in the specifications, it is understood that the brand or trade name referred to, or its approved equivalent, shall be furnished. If no mention is made of any exceptions, it is assumed that he is bidding on the article mentioned and not an approved equivalent. The bidder is requested to attach brochure-type information on the supplies furnished. All guaranteed and warranties should be clearly stated.

3. DISCREPANCIES

All pricing must appear in the spaces provided by the County's form (if applicable) and be in ink or typed. Changes or corrections by the bidder/proposer must be initialed in ink by the person signing. No corrections may be made in pencil. In case of error or discrepancy in the mathematics of the bid price, the unit prices shall prevail. The County will correct math computation errors (Unit Price & Totals). No bid may be altered or amended after bid opening time. Obvious mistakes will be given special consideration upon receipt of written request and full disclosure or evidence regarding pricing error.

4. SUBMITTAL OF SEALED BIDS/RFP/RFQ/ITQ

Any forms furnished by the County must be completed and returned as specified in the solicitation, otherwise response will be considered as non-responsive. TELEPHONE, FACSIMILE OR EMAIL RESPONSES WILL NOT BE ACCEPTED UNLESS OTHERWISE INDICATED. Electronic receipt of bids/proposals/quotes is acceptable for those **eligible for online submittal** at:

<https://vrapp.vendorregistry.com/Bids/View/BidsList?BuyerID=37b55d57-2b40-462f-bd8e-5b80ab095ddd>. **Paper Bid/RFP/RFQ submittals shall be sealed in an envelope.** No solicitation received after closing time shall be considered. The official time for paper submittals will be that of the date and time in the Purchasing Department. For electronic bids the official time is that posted on the website. Late submittals will not be accepted. Sullivan County shall not be responsible for technical difficulties experienced by vendors trying to register or submit their Bid/RFP response electronically less than one hour prior to the Bid/RFP/RFQ opening time.

5. TABULATIONS: BIDS/RFP/RFQ/ITQ

Tabulations for Bids/RFP/RFQ/ITQ will be posted on Vendor Registry, which is accessible through the County Purchasing website.

6. AWARD

An award, if made, shall be to the lowest responsible, responsive bidder(s) or best solicitation meeting quality and performance standards as described in the solicitation documents and whose Bid/RFP/Quote is determined to be the best interest of the County. The County also reserves the right to award this product/service based on other contracts in-place (state or cooperative contracts) as may be in our best interest. All contracts or purchase orders issued for this award will be governed by the laws of the State of Tennessee.

7. NO CONTACT POLICY

From the period beginning on the date of the issuance of this ITB any contact initiated by a proposer with any Sullivan County Representative concerning this proposal is strictly prohibited, unless such contact is made with the Purchasing Department Representative listed herein or with said Representative's authorization. Any unauthorized contact may cause the disqualification of the proposer from this Purchasing transaction. The Solicitation form must include an authorized signature and must be notarized for the bid to be accepted.

8. PROPRIETARY/CONFIDENTIAL INFORMATION

Vendors are hereby notified of all information submitted as part of, or in support of, bids/ proposals will be available for public inspection after award, in compliance with Tennessee Statutes unless the vendor additionally identifies a specific area or scope of data or other materials to be protected and details the reasons protection is necessary.

9. PAYMENT TERMS AND DISCOUNTS

Payment Terms are Net 30 following receipt of the material or service and a correct invoice unless otherwise stated in the solicitation document. Discounts for prompt payment will not be considered in the bid evaluation for award. In the event cash discounts are offered by the bidder, the discount date shall begin with the date of the invoice or the date of the receipt of all material covered by the order/contract, whichever is the later date.

10. CONDITION STANDARDS

It is understood and agreed that any item offered or shipped as a result of this solicitation shall be new and unused and the manufacturer's latest model unless otherwise called for in the solicitation.

11. DEFAULT

Default in promised delivery and failure to comply with specifications authorizes the County to purchase supplies elsewhere and charge the difference to the defaulting vendor.

12. TERM OF CONTRACT

The contract will be awarded for a period of one (1) year with a renewal option on an annual basis in one (1) year increments providing all terms, conditions and cost are acceptable to both parties. The County reserves the right to re-bid at the end of any contract period. The County may cancel any contract for cause, or non-appropriation of funds, following written notification of intent.

13. BREACH OF CONTRACT

A party shall be deemed to have breached the contract if any of the following occurs:

- Failure to provide products or services that conform to the contract requirements.
- Failure to maintain/ submit any report required hereunder.
- Failure to perform in full or in part any of the other conditions of the contract.
- Violation of any warranty.

14. CONTRACT TERMINATION FOR CAUSE

If the Contractor or Vendor fails to properly perform its obligations under this contract or purchase order in a timely or proper manner, or if the contractor violates any terms of this contract, the County shall have the right to terminate the contract and withhold payments in excess of fair compensation for completed services. In the event the contract is terminated for due cause by the County, the County shall have the option of awarding the contract to the next proposer or proposing again.

15. CONTRACT TERMINATION FOR CONVENIENCE

The County may, by written notice to the Contractor or Vendor to terminate this contract without cause for any reason. Said termination shall not be deemed a Breach of Contract by the County. The County must give notice termination to the vendor at least (30) days prior to the effective date of the termination. The Contractor or Vendor shall be entitled to receive compensation for satisfactory, authorized service completed as of the termination date, but in no event shall the County be liable to the Contractor for compensation for any service which has not been rendered. Upon such termination, the vendor shall have no rights to any actual general, special, incidental, consequential, or any other damages whatsoever of any description or amount.

16. ADDITIONAL PURCHASE OPTION

This Bid includes an option to allow Sullivan County, Tennessee the right to purchase additional vehicles/equipment. The County's use of this option will be dependent upon the price offered by the vendor and the availability of funding. The County may exercise this option clause for a period of twelve (12) months after the award of the Bid.

17. DELIVERY

Delivery/completion schedule must be clearly identified and realistically stated, as this may be a determining factor in the award.

18. FOB (FREE-ON-BOARD) POINT

All prices quoted shall be FOB destination, freight prepaid and allowed unless otherwise stated in the solicitation document. The seller pays and bears the freight charges and owns the goods while they are in transit. Title passes at the designated County location.

19. TAXES

The County is exempted from Federal excise taxes and state and local sales taxes and bidders must quote prices which do not include such taxes. An exemption certificate will be furnished upon request.

20. INDEMNIFICATION

The vendor shall guarantee and certify by submitting a response to this solicitation that if successful, they shall indemnify and defend the county against any and all claims or legal actions arising as a result of their performance of the contract, whether or not such claims relate to damages or alleged damages sustained by physical injury to contractors personnel, subcontractors, County employees or other persons, or against any lawsuits arising from alleged or actual patent infringements, and shall hold the County, its various departments, employees, and any and all persons or entities acting on its behalf harmless from the same.

21. INSPECTION

All supplies or materials purchased as a result of this solicitation are subject to inspection and rejection by the County. Rejected materials will be returned at the vendor's expense.

22. INSURANCE

The contractor shall maintain, at their expense, such insurance as required by the solicitation. Such insurance shall protect the County for claims of damages which may arise during operations under this contract whether such operations be by the Contractor or by any Subcontractor or anyone directly or indirectly employed by either of them. Any required insurance shall be maintained for the term of the contract and beyond the term of the contract when so required in the solicitation.

23. FORCE MAJEURE

In the event that the performance of any obligation under this contract, by either party, is prevented due to acts of God, exchange controls, export or import controls, government restriction, wars, hostilities, blockades, civil disturbances, revolutions, strikes, terrorist attacks, lockouts, pandemics, epidemics, plague, outbreaks of infectious disease, including but not limited to COVID-19, any other public health crisis, including stay at home orders, group size restrictions, travel restrictions, or employee restrictions, issued by the Governor or a public health authority, such as Sullivan County Regional Health Department, or recommendation of the Center for Disease Control or the National Institutes of Health to limit the spread of COVID-19, or any other cause beyond the reasonable control of a party, such party will not be responsible to the other party for failure or delay in performance of its obligations under this Contract. Each party will promptly notify the other party of such Force Majeure condition and make good faith efforts to ensure goods or services are provided as per the contract. However, if Force Majeure conditions occur and both parties mutually agree, this contract may be cancelled. If cancelled, neither party will be considered in breach of contract. If funds have been paid for products or services that have not been received, the vendor will send the County a refund within thirty (30) days of the cancellation.

24. WARRANTY

Unless otherwise specified by the County, all items shall be guaranteed for a minimum period of one (1) year against defects in material and workmanship.

25. EQUAL OPPORTUNITY

It is the policy of Sullivan County to ensure compliance with Title VI of the Civil Rights Act of 1964; 49 CFR, Part 21; related statutes and regulations to that end that no person shall be excluded from participation in or be denied benefits or be subjected to discrimination under any program or activity receiving Federal financial assistance or any other funding source on the grounds of race, color, sex, national origin, or ancestry. By virtue of submitting a response to this solicitation, vendors agree to comply with the same non-discrimination policy.

26. IRAN DIVESTMENT

Pursuant to the Iran Divestment Act Tenn. Code Ann. § 12-12-106 requires the State of Tennessee Chief Purchasing Officer to publish, using credible information freely available to the public, a list of persons it determines engage in investment activities in Iran, as described in §12-12-106. Inclusion on this list makes a person ineligible to contract with Sullivan County; if a person ceases its engagement in investment activities in Iran, it may be removed from the list. The State of Tennessee list is available here: <http://tennessee.gov/generalservices/article/Public-Information-Library> Submission of this bid/quote/proposal, each vendor and each person signing on behalf of any vendor certifies, and in the case of a joint bid/quote/proposal, each party thereto certifies as to its own organization, under penalty of perjury, that to the best of its knowledge and belief that each vendor is not on the list created pursuant to § 12-12-106

27. NON-COLLUSION AGREEMENT

By submitting this solicitation, the agent representing all officers, partners, owners, representatives, employees or interested parties of the vendor's firm certifies to the best of his/her knowledge and belief this bid/proposal submitted to Sullivan County, Tennessee has not been prepared in collusion with any other seller, proprietor, or manufacturer of similar products or services. The agent also certifies that the prices, terms, and conditions of said bid/proposal have been arrived at independently and have not been communicated by the submitter, nor by any of the aforementioned firm associate to any other seller, proprietor, or manufacturer of similar products or services and will not be communicated prior to the official opening of said solicitation. The agent further states that no official or employee of Sullivan County, Tennessee has promised any personal, financial, or other beneficial interest, either directly or indirectly, in order to influence award of this solicitation.

28. CONFLICT OF INTEREST

a) No Board Member or officer of the County or other person whose duty it is to vote for, oversee or in any manner superintend any of the work for the County has a direct interest in the award of the vendor providing goods or services.

b) No employee, officer or agent of the grantee or sub-grantee will participate in selection, or in the award or administration of an award supported by Local, State or Federal funds if a conflict of interest, real or apparent, would be involved. Such a conflict would arise when the employee, officer or agent, any member of their immediate family, his or her partner, or an organization, which employs, or is about to employ, any of the above, has a financial or other interest in the firm selected for award.

c) The grantees or sub-grantees officers, employees or agents will neither solicit nor accept gratuities, favors or anything of monetary value from vendors, potential vendors, or parties to sub-agreements.

d) Do you or any officers/part-owners/stakeholders/employees of this company have any relative(s) (relatives include spouse, children, stepchildren, or any to whom you are related by blood or marriage) that are currently employed by Sullivan County, Tennessee, including the Sullivan County School System or serve on the Sullivan County Commission or the Sullivan County Board of Education? _____ Yes _____ No
If you answered yes, please state the name and relationship of the employee or member of Sullivan County Commission or Sullivan County Board of Education member _____

e) Are you or any officers/part-owners/stakeholders/employees of this company also employees of Sullivan County, including the Sullivan County School System or serve on the Sullivan County Commission or Sullivan County Board of Education? _____ Yes _____ No

If you answered yes, please state the name of the employee or Commission member or Board member

f) By submission of this bid, the vendor is certifying that no conflicts of interest exist.

29. DRUG FREE WORKPLACE REQUIREMENTS

Private employers with five or more employees desiring to contract for construction services attest that they have a drug free workplace program in effect in accordance with TCA 50-9-112.

30. ELIGIBILITY

The vendor is eligible for employment on public contracts because no convictions or guilty pleas or pleas of nolo contendere to violations of the Sherman Anti-Trust Act, mail fraud or state criminal violations with an award from the State of Tennessee or any political subdivision thereof have occurred.

31. PROTEST POLICY

Any protest to a bid award by Sullivan County shall be submitted in writing to the Purchasing Agent with a copy to the Sullivan County Mayor and delivered not later than seven (7) calendar days from the date of the county's award decision. Such protest must include a protest bond in the amount of \$350 (Cashier's Check payable to the Sullivan County Trustee or Cash) submitted to the Purchasing Agent before the County will consider the protest. This protest bond will serve as a guarantee by the protester of the validity and accuracy of the protest. If the protest is denied by the County Mayor, the bond will be retained to cover costs associated with the protest. The steps for dispute resolution may include:

- A meeting with the Purchasing Agent, the requisitioning Department Manager, and representatives from the disputing party to discuss and resolve the complaint.
- Information from the aforementioned meeting will be forwarded to the County Attorney for review.
- A written decision letter stating the reasons for the decision will be prepared by the Purchasing Agent and submitted in writing to the protester and all parties involved.
- Purchases will not be allowed under this procurement until a final decision is rendered.
- In the event that purchases must be made before a final decision is rendered, the emergency purchase procedure will be used.

32. GOVERNING LAW

All contracts or purchase orders issued for this award will be governed by the laws of the State of Tennessee. Arbitration is not permitted and if disputes arise between the parties concerning any aspect of the contract and /or purchase order and it cannot be resolved by mutual agreement, any party may resort to resolution of the dispute by litigation in the state or federal courts for Sullivan County, Tennessee. The parties waive their right to jury trial. Mandatory and exclusive venue and jurisdiction for any disputes shall be in state or federal courts for Sullivan County, Tennessee.

33. BACKGROUND CHECK REQUIREMENT FOR SCHOOL SYSTEM SUPPLIERS

a) In submitting this bid/quote/proposal, you are certifying that you are aware of the requirements imposed by TCA § 49-5-413 (d) to conduct criminal background checks through the Tennessee Bureau of Investigation and the Federal Bureau of Investigation on yourself and any of your employees who may come in direct contact with students or who may come on or about school property anytime students are present. You are further certifying that at no time will you ever permit any individual who has committed a sexual offense or who is a registered sex offender to come in direct contact with children or to come on or about school property while students are present.

34. BUY AMERICA REQUIREMENTS

Vendor agrees to comply with 49 C.F.R. part 661 and 2 CFR § 200.322 Domestic Preferences for procurements, which provide that Federal Funds may not be obligated unless all steel, iron and manufactured products used in federally funded projects are produced in the United States, unless a waiver has been granted or the products is subject to a general waiver. General Waivers are listed in 49 C.F.R. § 661.7. By submission of this bid/quote/proposal, each vendor and each person signing on behalf of any vendor certifies compliance with the Buy America Requirement.

35. CLEAN AIR ACT

Vendor agrees to comply with all applicable standards, orders, or regulations issued pursuant to the Clean Air Act (42 U.S.C. § 7401-7671q.)

36. FEDERAL WATER POLLUTION CONTROL ACT

(1) Vendor agrees to comply with all applicable standards, orders, or regulations issued pursuant to the Federal Water Pollution Control Act, as amended, 33 U.S.C. 1251 et Seq.

(2) Vendor agrees to report each violation to the Agency and understands and agrees that the Agency will, in turn, report each violation as required to assure notification to the Federal Emergency Management Agency, and the appropriate Environmental Protection Agency Regional Office.

(3) Vendor agrees to include these requirements in each subcontract exceeding \$150,000 financed in whole or in part with Federal Assistance.

37. SUSPENSION AND DEBARMENT

Federally Funded procurements must not be awarded to parties that are listed on the governmentwide exclusions in the System for Award Management (SAM.gov), in accordance with the OMB guidance at 2 C.F.R. 180 that implement Executive Orders 12549 (3 C.F.R. part 1986 Comp., p. 189) and 12689 (3 C.F.R. part 1989 Comp., P.235). "Debarment and Suspension" Sam exclusions contain the names of the parties debarred, suspended, or otherwise excluded by agencies, as well as parties declared ineligible under statutory or regulatory authority other than Executive Order 12549. Entities must be registered in the SAM.gov website to be considered for award.

(1) Any agreement or award resulting from this bid is a covered transaction for purposes of 2 C.F.R. pt. 180 and 2 C.F.R. pt. 3000. As such, the vendor is required to verify that none of the vendor's principals (defined at 2 C.F.R. § 180.995) or its affiliates (defined at 2 C.F.R. § 180.905) are excluded (defined at 2 C.F.R. § 180.940) or disqualified (defined at 2 C.F.R. § 180.935).

(2) The vendor must comply with 2 C.F.R. pt. 180, subpart C and 2 C.F.R. pt. 3000, subpart C, and must include a requirement to comply with these regulations in any lower tier covered transaction it enters into.

(3) By Submission of this bid, vendor is certifying compliance with the requirements of 2 C.F.R. pt. 180, subpart C and 2 C.F.R. pt. 3000, subpart C while this offer is valid and throughout the period of any contract or award that may arise from this offer.

38. BYRD ANTI-LOBBYING AMENDMENT

Vendors who bid for award of \$100,000 or more shall provide the required certification. Each tier certifies to the tier above that it will not and has not used federal appropriated funds to pay any person or organization for influencing or attempting to influence an office or employee of a member of any agency, a member of Congress, officer or employee of Congress, or an employee of a member of Congress in connection with obtaining any Federal contract, grant or any other award covered by 31 U.S.C. § 1352. Each tier shall also disclose any lobbying with non-federal funds that takes place in connection with obtaining any Federal award. Such disclosures are forwarded from tier to tier up to the Agency. By submission of this bid, vendor is certifying compliance with these requirements.

39. PROCUREMENT OF RECOVERED MATERIALS

A non-Federal entity that is a state agency or agency of a political subdivision of a state and its contractors must comply with section 6002 of the Solid Waste Disposal Act, as amended by the Resource Conservation and Recovery Act. The requirements of Section 6002 include procuring only items designated in guidelines of the Environmental Protection Agency (EPA) at 40 C.F.R. part 247 that contain the highest percentage of recovered materials practicable, consistent with maintaining a satisfactory level of competition, where the purchase price of the item exceeds \$10,000 or the value of the quantity acquired during the preceding fiscal year exceeded \$10,000; procuring solid waste management services in a manner that maximizes energy and resource recovery; and establishing an affirmative procurement program for procurement of recovered materials identified in the EPA guidelines.

(1) In the performance of this contract, the vendor shall make maximum use of products containing recovered materials that are EPA-designated items unless the product cannot be acquired-

- i. Competitively within a timeframe providing for compliance with the contract performance schedule;
- ii. Meeting contract performance requirements; or
- iii. At a reasonable price.

(2) Information about this requirement, along with the list of EPA-designate items, is available at EPA's Comprehensive Procurement Guidelines website, <https://www.epa.gov/smm/comprehensive-procurement-guideline-cpg-program>.

40. ACCESS TO RECORDS AND REPORTS

(1) Record Retention. The vendor will retain and will require any subcontractors of all tiers to retain, complete and readily accessible records related in whole or in part to the contract, including, but not limited to, data, documents, reports, statistics, sub-Contracts, leases, subcontracts, arrangements, other third-party Contracts of any type, and supporting materials related to those records.

(2) Retention Period. The vendor agrees to comply with the record retention requirements in accordance with 2 C.F.R. § 200.333. The vendor shall maintain all books, records, accounts, and reports required under this Contract for a period of at not less than three (3) years after the date of termination or expiration of this Contract, except in the event of litigation or settlement of claims arising from the performance of this Contract, in which case records shall be maintained until the disposition of all such litigation, appeals, claims or exceptions related thereto.

(3) Access to Records. The vendor agrees to provide sufficient access to the Federal and State Government and its contractors to inspect and audit records and information related to performance of this contract as reasonably may be required.

(4) Access to the Sites of Performance. The vendor agrees to permit Federal and State Government and its contractor's access to the sites of performance under this contract as reasonably may be required.

41. COMPLIANCE WITH FEDERAL LAW, REGULATIONS AND EXECUTIVE ORDERS

Vendor acknowledges that Federal Grant Funds will be used to fund all or a portion of this bid. The Vendor agrees to comply with all applicable Federal law, regulations, executive orders, policies, procedures, and directives.

42. NO OBLIGATION BY FEDERAL GOVERNMENT

The Agency and Vendor acknowledge and agree that, notwithstanding any concurrence by the Federal Government in or approval of the solicitation or award of the underlying Contract, absent the express written consent by the Federal Government, the Federal Government is not a party to this Contract and shall not be subject to any obligations or liabilities to the Agency, Vendor, Contractor, or any other party (whether or not a party to that contract) pertaining to any matter resulting from the underlying Contract.

43. PROGRAM FRAUD AND FALSE OR FRAUDULENT STATEMENTS AND RELATED ACTS

The Vendor acknowledges that 31 U.S.C. Chap. 38 (Administrative Remedies for False Claims and Statements) applies to the vendor's actions pertaining to any contract resulting from this bid.

44. SIGNATURE REQUIREMENTS

All submittals must contain the full name of the company, must be signed by a person authorized to bind that company to a contract and notarized. Submission response to the solicitation constitutes acceptance of all terms and conditions included herein. Unsigned forms will not be considered, read, or tabulated. Bid forms may not be signed during or after the bid opening, even if a representative is present.

GENERAL PROVISIONS

1. The unit(s) and associated equipment shall be furnished complete and in readiness for use.
2. Special Awarding Criteria. While the purpose of the bid document is to indicate certain minimum requirements, its use is not intended to relieve Sullivan County of all responsibility in making a selection which is the most suitable for the Sullivan County EMS Department. Although proposals may be received based on the minimum requirements indicated, it is not intended that this alone shall limit the award, but other factors will be considered, including the experience of Sullivan County and others.
3. Trade-in. N/A
4. Optional Equipment. Selection of Optional Equipment will be at the discretion of the Sullivan County EMS Department. A separate cost sheet may be included if needed for optional equipment.
5. Specifications: See Vehicle Specifications – pages 9 - 88.
6. Bidder is requested to fill out the Bid Form, General Terms and Conditions (Page 5, Section 28) and attach a completed copy of the Vehicle Specifications (Pages 9 - 88).
7. Any additions, deletions, variations from attached specifications must be noted. Any items appearing in manufacturer's regular published specifications furnished by bidder are assumed to be included in the "Bidder's Proposal".
8. At time of delivery to Sullivan County Central Receiving, vehicle must meet or exceed all federal, state, and local health, safety, lighting, and noise standards.
9. At time of delivery to the Sullivan County Central Receiving, vehicle must meet or exceed all the latest revision to Federal Specification KKK-A-1822, Federal Motor Vehicle Safety Standards (FMVSS), national truck equipment association (NTEA) Ambulance Manufacturer's Division (AMD) Standards and Ford Qualified Vehicle Modifier (QVM) Program Truck Guidelines.

SULLIVAN COUNTY EMS

In addition to build specs, the following are requested.

Ambulance to be built on a 2022 Ford F-450 4x4 XLT or higher trim, 6.7 power-stroke diesel with a 169.3" WB and 84" CA. The module is confirmed to be 154"L x 95"W x 72"H.

1. The ambulance shall be priced FOB Blountville, but the vendor shall provide funds for pickup and inspection of the ambulance by Sullivan Co. EMS personnel at the vendor's factory.
2. Module exterior compartments and interior cabinetry shall match provided drawings.
3. The cab floor console will be **customized** to include pockets at the rear to hold manuals and glove boxes. The console will also have to siren installed and allow room for 2 radio heads. Drawing provided.
4. There shall be a quick disconnect plug system in rear or bottom of the cab which allows for cab removal from the chassis and separation of the module wiring harness. **NO EXCEPTIONS!**
5. Phoenix stainless steel full wheel covers shall be shipped loose in the unit.
6. Cmpt M2 will have a fixed vertical divider for long boards. Two buckle straps shall be provided for backboard restraint.
7. Cmpt M7 shall have two adjustable aluminum shelves.
8. Cmpt, M2, and M6 shall each have one adjustable aluminum shelf each.
9. Cmpt "M3" shall have two adjustable shelves.
10. Compartment M1 shall have Ziamatic QR-GH tank holder mounted in corner of walls 2 and 3 to allow ease of loading according to current KKK standards.
11. Upper windows in all three module doors are to be sliding glass with screens. Lower windows shall be provided in both rear doors. All are to be "Privacy" tint.
12. Electrically switched locks shall be installed on the C/S and Rear entry doors, and also on Cmpt's "M3" and "M7". These shall be switched with the OEM cab door locks. Wiring connection shall be via coil type wiring thru the inside panel of door.
13. A "Stealth" switch shall be installed in the passenger side front tow hook area for the door locks.
14. Aluminum diamond plate running boards shall be installed on the cab. These running boards will extend from the rear of the front wheel well opening to the rear of the cab. The boards will be narrower at the wheel well, and flare wider to have their outer edge align with the width of the front of the module body at their rear. At the forward edge of the running board will be installed vertical stone/mud guards 11" tall and arched from the outer edge of the running boards inward to the wheel well edge. The running boards shall be attached only to the cab and NOT to the module. They shall be adequately reinforced to support attachment and driver entry/exit weight. Boards shall include "grip strut" inserts, or some other aluminum "non-slip" installation.

15. The lower edge (Sill) of all compartments shall be covered with polished stainless steel (sill protectors), to prevent damage to paint when equipment is removed.
16. Ambulance shall be white in color and shall be striped and lettered using 3M reflective material to match existing fleet. Pictures will be provided by customer upon request. **NO EXCEPTIONS!**
17. There shall be at least one visible flashing red LED light on the inside of the curbside door to be activated when the door is open to warn motorists
18. Roof decals to be installed by factory and includes a 32-inch star of life and 14-inch M-(?); both in reflective blue.
19. Coax shall be prewired for our radio system. Additionally prewires shall be installed (positive and negative) for radio power, 20 amps, ignition hot.
20. Rear Back-up Camera: Install rear back-up camera above rear doors (or as high as possible with OEM camera) which is to be hard wired to the factory screen when placed into reverse. Chassis will be ordered to allow connection to OEM system.
21. Outlets for 110-volt shall be installed as follows: one in the A/A; one duplex outlet will be installed in the telemetry area, one above the bench seat on foot end, one installed under the pass-thru window (on the bulkhead), one in the passenger sidewall of front console and one outlet in cmpt. "M7" left side wall.
22. An inverter / battery charger, see specifications attached below. It shall be installed in the bottom of compartment M2 and wired to power on with ignition and have remote panel installed in the action area switch panel.
23. Shoreline shall be 20 Amp Kussmaul Super Auto-eject With Interrupter.
24. A quick connect plug assembly and jumper cables (to jump start the vehicle) shall be provided: a female plug shall be installed on top of the bumper, a male mating plug and 25' extra heavy duty jumper cables shall be shipped loose in the ambulance.
25. The siren amp shall be a Whelen 295 HFSC9 mounted in the console per drawing.
26. Two Siren speakers shall be installed in the front bumper via Cast Products speakers. If chassis is delivered with factory fog lights and removal should be required, install (2) 100-watt Whelen speakers behind grill.
27. There shall be Whelen M7 LED red flash/clear lens on either side of module above each rear fender well. These shall be on a separate switch.
28. A switch shall be provided on the console to activate the low power option for LED's.
29. (2) Whelen M9 rear load lights shall be installed per attached drawing.
30. In the center of the rear of module between the load lights shall be (2) Whelen M7 LED's. One over top of the other per attached drawing. The top M7 shall be red bulbs/clear lens and wired as a brake light. The bottom M7 shall be amber flash/clear lens and be wired per KKK with all warning lights.
31. The center light on front of module shall be a Whelen M9C LED as per attached drawing.
32. The grill flashers shall be a total of (4) Whelen M2 LED's. Red flash/clear lens.

33. The OEM Grill will be used, and the grill lights will be housed in Whelen flanges.
34. The intersection lights shall be Whelen M2 split red/clear flash. They shall be housed in Whelen chrome flanges in a horizontal plane.
35. All LED warning lights are to be sequenced by a Whelen AFM-560 flasher in KKK pattern. Default flash pattern shall be "comet flash".
36. Each side of the module shall have (2) Whelen M9L2C LED load / scene lights.
37. Integrated flush into each upper corner of the mod roof (corner caps) will be a combination DOT marker light/high intensity LED flashers. These shall be on a separate switch. **NO EXCEPTION!**
38. The rear brake / taillights shall be Whelen M6 Maximum Output LED's. The turn signals shall be Whelen M6 Amber maximum output LED turn arrows. The lower backup lights shall be Whelen #M6 LED. These shall be mounted in a protective polished mounting housing as In pictures provided. These will not be mounted in the rear diamond plate kick panel. **NO EXCEPTIONS!**
39. All DOT running lights and bumper lights shall be LED.
40. Lights shall be installed to illuminate the running boards, and switched with the cab door light switches. These shall be four-inch round LED's.
41. The lights installed in the exterior compartments shall be LED light strips providing light from top to bottom of compartment.
42. Dome lights (7) in patient area shall be LED by Whelen. Minimum light output shall be 950 Lumens each.
43. In addition to the dome lights, three fluorescent lights shall be installed, and switched separately in the patient area dome.
44. An "inventory timer" switch shall be installed beside the C/S entry door, this shall be wired constant hot, and connected to the fluorescent lights.
45. An additional rocker switch shall be installed on the front console for the patient area "Left High Domes", and so labeled.
46. Reflective insulation shall be installed, (with all seams taped and sealed) instead of the standard batting insulation.
47. The oxygen system shall include two outlets in the A/A, one on the C/S wall, one in the ceiling above the pt head end of the cot (recessed) and a suction outlet in the A/A.
48. For the safety of the Medic; a heavy-duty net constructed of sewn seat belt material shall be installed at the head of the squad bench. This net shall be mounted with quick release brackets which are bolted into the aluminum structure of the ceiling, wall, and floor. Simply screwing into the mounting brackets into the cabinetry shall not be acceptable.
49. The cot mount anchors in the floor Shall be positioned so that the foot of the cot is no closer to the rear doors than 14 inches.
50. A Stryker floor plate assembly for Power Load with inductive charging will be installed for a center mount.

51. Stainless steel "cot plates" shall be installed under the cot wheels running from rear to front.
52. The rear attendant seat shall be an "EVS" brand and include a fold down infant's seat and three-point restraints for the medic.
53. A diamond plate aluminum door shall be installed in the EVS seat base.
54. Cabinetry shall match our attached drawings, (to conform to the rest of our fleet).
55. In addition to a keyed lock on narc cabinet, an electronic combination lock shall also be installed. The lock shall be a CompX eLock 300 series cabinet style wired with 12-volt from the vehicle.
56. Installed into the Lower portion of the curbside door shall be a removable trash container.
57. Gas struts, (60 lbs.) shall be used to as hold open devise on the bench lid.
58. Installation of EVS Ltd 2160WMB BackPack Belting System in place of standard 5point restraints for bench seats and CPR seat locations. Back rests only in matching color.
59. All cabinetry windows shall be Lexan. No Plexi glass will be accepted.
60. All interior cabinets, shall have hinged "**Restocking**" type doors.
61. Cabinet B shall have horizontal and vertical dividers installed to divide the cabinet into six equal "pigeon holes" for storage of IV bags. Pictures provided if needed.
62. Stainless Steel kick panels shall be installed to bottom of bench and side wall cabinets. Also, at the head of the bench.
63. All module entry doors to be equipped with oversized "L" shaped interior grab handles, painted safety yellow.
64. Two Ohio flow meters, and two "H" gauge and oxygen regulator shall be shipped loose in the ambulance.
65. Two, five lb. Fire extinguishers with marine mounting brackets shall be shipped loose.
66. The spare tire shall be shipped loose.
67. There shall be two chrome tow eyes recessed in rear kick panel of module which are attached to the frame and not the kick panel.
68. There shall be four Cast Products (grabbers) installed for hold open devices for rear entry doors.
69. Hold open devices for all other compartments and side entry door shall be gas struts.
70. The module floor covering shall be Lon Plate gun powder in color.
71. Installation of composite sub-floor ILOS.
72. Compartment M3 is to be equipped to hold an additional "H" O2 cylinder Per current KKK standards. Ziamatic QR-GH tank holder mounted in corner of walls 1 and 2 to allow ease of loading. The cylinder will be plumbed into the main O2 system with a switch / valve (located in the action area) to select front or rear O2 tank. There will be a vertical divider installed to separate and seal off the oxygen cylinder from the

remainder of the compartment. The remaining section of the compartment shall have two adjustable shelves installed.

73. Cradlepoint installation to include Router IBR900-600-NPS, Transportation 5 in 1 antenna mounted on the module and Verizon setup.
74. LED underbody lighting to provide coverage from the cab door rearward.
75. Medi-cool Dual temp H/Saline Depth to be installed above interior M7. This shall be locked with a key.
76. All exterior compartment to have LED lighting along the interior vertical jamb from top to bottom of interior opening. These shall be illuminated when compartment door is opened.
77. ALS cabinet shall have 1 solid interior door in place of webbing.
78. To the left of curbside stepwell, beneath head of the bench, should be mounted two Zico QR-D-2
79. USB and Mini USB outlets will be provided in the front console and rear action area.
80. Curbside forward of the rear tire will be a 6inch drop to add an additional entrance step.
81. A handheld spotlight will be installed and hard wired in the cab of unit.
82. Install of an external A/C condenser mounted to front of module just below the guttering utilizing a molded / formed integral appearing cover which can accept 5 M9 series Whelen LED's with the outer 2 being at a near 45 degree angle to the module for additional warning light coverage. The covering will be aesthetically pleasing, match the color of the module and provide proper ventilation. The condenser must be easily accessible for maintenance and inspection. If this option is chosen, there shall be one additional M9 at each side of the cover to provide 7 total on the front of the module.
83. All external Whelen LED's will have Whelen chrome surround flange installed.
84. Install reinforced rear bumper with skid rails and flip up center.

Each of these shall be priced separately unless part of standard package.

All Bids must include detailed computer drawings that accurately reflect the finished product.

Any and all exemptions will be noted by bidder.

Invitation to Bid
For
Ambulance(s) and Equipment

The Sullivan County Purchasing Department on behalf of the Sullivan County EMS Department is soliciting competitive, sealed bids from qualified vendors for the purchase of four (4), Type I (4 x 4) ambulances.

The attached specification defines a commercial emergency medical vehicle, built to withstand adverse driving conditions. The vehicle shall meet or exceed the latest revision to Federal Specification KKK-A-1822, Federal Motor Vehicle Safety Standards (FMVSS), national truck equipment association (NTEA) Ambulance Manufacturer's Division (AMD) Standards and Ford Qualified Vehicle Modifier (QVM) Program Truck Guidelines.

GENERAL CONDITIONS:

PARTY IDENTIFICATION:

AGENCY: "Agency" is hereinafter defined as the customer. The customer is an individual or a group of individuals who represent the interest of the city, borough, county, parish, state or private enterprise and has been charged with the responsibility of purchasing one or more emergency medical vehicle(s).

Bidder Complies YES_____ NO_____

BIDDER: "Bidder" is hereinafter defined as the vehicle manufacturer and/or its authorized representative. The bidder is an assigned representative who is authorized to commit to a contract with the "Agency".

Bidder Complies YES_____ NO_____

VENDOR: "Vendor" Is Synonymous with "Bidder".

Bidder Complies YES_____ NO_____

NOTICE TO BIDDERS: Bidders shall thoroughly examine any drawings, specifications, schedule, instructions, and any other documents supplied as part of this invitation to bid.

Bidders shall make all investigations necessary to thoroughly inform themselves regarding the content of the written specifications, drawings and instructions supplied herein. No pleas of ignorance by the bidder pertaining to the content of the specifications, drawings, schedule or instructions will be considered by the agency once the deadline for bid submission has occurred. Failure or omission on the part of the bidder to make the necessary examinations and investigations into the content of the specifications shall not be accepted as a basis for making variations to the spec. Failure or omission by the bidder to make all clarifications or explanations of exceptions and conditions that exist or that may exist hereafter shall not be accepted as a basis for making variations to the requirements of the agency or compensation to the bidder.

Bidder Complies YES_____ NO_____

DEFINITIONS:

CLARIFICATIONS: Clarifications shall be written correspondence between the bidder, the agency and all other qualified bidders. A clarification shall include the paragraph number, page number, the text with unclear content (as written in the specification) and the definition of the clarification

requested. Verbal clarifications shall be documented in writing and distributed to all other qualified bidders at least two business days prior to the deadline for bid submission.

EXPLANATION OF EXCEPTIONS: Bidders may take exceptions to any part of the bid contained herein with a written itemized schedule. The schedule shall include the paragraph number(s), the text that the bidder feels he can not comply within an explanation why the bidder feels that the requirement is not in the best interest of the agency and/or an alternate bidder solution. Alternate bidder solutions may be considered by the agency, if the bidder can show the agency that the alternate solution is, in quality and quantity, equal to or better than the specified item. This agency will share the exception/alternate solution with all other qualified bidders. Explanation of exceptions shall be documented in writing at least two business days prior to the deadline for bid submission.

Bidder Complies YES_____ NO_____

CORE DESIGN INTENT: The core design intent of the specifications supplied herein is to purchase an ambulance with the highest level of engineering excellence. The "core design" intent of this vehicle shall be centered on the patient's need for pre-hospital care, in conjunction with a safe working environment for the emergency medical personnel.

Bidder Complies YES_____ NO_____

BID PACKAGES SHALL NOT TAKE TOTAL EXCEPTIONS: Bidders are required under this bid invitation to give, for the consideration of the agency, a proposal that will comply with the written specifications, drawings and schedules supplied herein. The specifications supplied represent a compilation of input from all disciplines of users, patients, maintenance and management personnel who are directly affected by the vehicle's performance.

Careful consideration pertaining to safety, configuration, construction, and workmanship are based on working experiences by all the personnel who have direct, working contact with the subject vehicle specified herein. The "core design" of this ambulance was created as a result of resolving issues and improvement suggestions that have originated from the personnel most QUALIFIED to make such input.

Bid Opening Date.

Caution:

A bidder who submits a bid that takes "total exception" and makes an offering of some "standard" or "stock" unit will be viewed by the agency as a bidder who did not make, and is not prepared to make, a valid bid, and is not qualified to manufacture the ambulance as specified herein. Alternate bids will not be considered.

Bidder Complies YES_____ NO_____

VEHICLE QUANTITY: THIS AGENCY is currently seeking to purchase one vehicle per the specifications set forth in this solicitation for bid. This agency and/or other government or private agencies that qualify to purchase under this contract will reserve the right to increase the number of vehicles purchased without incurring an obligation to obtain bids from other vendors for a period of two years. A contract extension may be provided to the successful, qualified vendor who has performed satisfactorily to the original contract.

Bidder Complies YES_____ NO_____

VENDOR QUALIFICATIONS:

FORD QVM: All bidders shall be members in good standing of the Ford Motor Company's qualified vehicle modifier program (QVM). Each bidder shall supply a copy of their valid QVM certification with their bid package. If for any reason the QVM certification has been withdrawn or suspended by Ford Motor Company within the past five years, the bidder shall supply a full written explanation as to why it was withdrawn. The written explanation shall include any corrective actions taken to regain the QVM certification.

Bidder Complies YES_____ NO_____

PRODUCT LIABILITY INSURANCE: Proof of current liability insurance shall be supplied. The proof of insurance shall bear the insurance carrier's name, address and phone number. The proof shall also bear the name and address of the insured. This document shall contain the coverage schedule, explaining the type of insurance, the policy number, the effective date of coverage, the policy expiration date and the individual limits. The minimum amount of coverage shall be as follows in USD:

Commercial General Liability - As Follows:

Each Occurrence: \$1,000,000

Damage to Rented Premises, Each Occurrence: \$300,000

Personal and Adv Injury: \$1,000,000

General Aggregate: \$4,000,000

Products - Comp/OP Agg: \$4,000,000

Automotive Liability - Combined Single Limit: \$2,000,000

Garage keepers - Limit \$1,000,000.

Excess Liability - Occur

Each Occurrence: \$5,000,000

Limit-Quota Share: \$10,000,000

Workers Compensation and Employers' Liability

E.L. Each Accident: \$1,000,000

E.L. Disease Policy - Each Employee: \$1,000,000

E.L. Disease - Policy Limit: \$1,000,000

Bidder Complies YES_____ NO_____

NON-DISCRIMINATION AND EQUAL OPPORTUNITY: The bidder/contractor agrees to comply with all federal statutes relating to non-discrimination. These include but are not limited to:

(a) title vi of the civil rights act of 1964 (p.l. 88-352) which prohibits discrimination on the basis of race, color or national origin:

(b) title ix of the education amendments of 1972, as amended (20 U.S.C. 16811683, and 1685-1686), which prohibits discrimination on the basis of sex:

(c) section 504 of the rehabilitation act of 1973, as amended (29 U.S.C 794), which prohibits discrimination on the basis of handicaps and the Americans with disabilities act of 1990:

(d) the age discrimination act of 1974, as amended (42 U.S.C. 6101-6107), which prohibits discrimination on the basis of age:

(e) the drug abuse office and treatment act of 1972 (p.l. 92-255), as amended, relating to nondiscrimination on the basis of drug abuse:

(f) the comprehensive alcohol abuse and alcoholism prevention, treatment and rehabilitation act of 1970 (p.l. 91-616), as amended, relating to nondiscrimination on the basis of alcohol abuse or alcoholism:

(g) 523 and 527 of the public health service act of 1912 (U.S.C. 290 dd-3 and 290 ee-3), as amended, relating to confidentiality of alcohol and drug abuse patient records:

(h) title viii of the civil rights act of 1968 (42 U.S.C. 3601 et seq.), as amended, relating to nondiscrimination in the sale, rental or financing of housing:

(i) any other nondiscrimination provisions in any specific statute(s) applicable to any federal funding for this agreement:

(j) the requirements of any other nondiscrimination statute(s) which may apply to this agreement.

Bidder Complies YES_____ NO_____

DRUG FREE WORKPLACE: The bidder shall conduct business as a drug free workplace. The bidder/manufacturer and all of its sub-contractors shall provide notice to their employees and sub-contractors as required under the drug-free workplace act of 1988. A copy of bidder's drug-free workplace policy shall be furnished to this agency upon request.

Bidder Complies YES_____ NO_____

QUALITY MANAGEMENT SYSTEM REGISTERED: The manufacturer shall have a certificate of registration for iso 9001(tm) 2015 for their quality management system (QMS). The QMS provides establishment, documentation, implementation, maintenance and improvement of management systems that impact the final quality of the product. Registration of the vendor's QMS demonstrates an enduring commitment to quality, a sharp focus on the customer, and robust communication throughout the product process chain to the customer. This registration provides for oversight with routine inspection of the QMS to maintain certification status. Proof of certification shall be readily available upon demand. Proof of certification shall be provided with bid during initial bid process.

Bidder Complies YES_____ NO_____

NATIONAL TRUCK EQUIPMENT ASSOCIATION TESTING

AMD 001 AMBULANCE BODY STRUCTURE STATIC LOAD TEST: The ambulance described herein shall be type tested to the national truck equipment association's ambulance manufacturing division, standard 001 ambulance body structure static load test except the test weight shall be a minimum of two and a half (2-1/2) times the curb weight of the built vehicle.

AMD 003 OXYGEN TANK RETENTION SYSTEM STATIC TEST: The ambulance described herein shall be type tested to the national truck equipment association ambulance manufacturing division, standard 003 - oxygen tank retention system static test. The test shall be conducted by an independent testing laboratory.

Safety is this agency's first concern. Main cylinder control is extremely important and is crucial to the safety of the patient, public passengers and crew. If the bidder has experienced a cylinder rack separation from the oxygen compartment wall, or if the cylinder has come loose from the cylinder restraining device, then the bidder shall supply this agency with a report containing the date, a full explanation of the incident and corrective actions taken to prevent future failures. Main oxygen/air cylinders that come loose during a collision indicate mechanical defects in the design of the restraining device or the mounting method. Any AMD standard 003 testing prior to the incident is deemed invalid, regardless of the expiration date of the original test.

AMD 004 LITTER RETENTION SYSTEM STATIC TEST: The cot/litter retention system described herein shall be tested to the national truck equipment association, ambulance manufacturing division standard 004 - litter retention system static test. The cot mount hardware, mounting method and floor reinforcement areas shall exceed the test as described in AMD 004. This test shall be conducted by an independent testing laboratory.

Safety is this agency's first concern. Main cot/litter retention is critical to patient care. If the bidder has experienced a litter ejection due to a hardware defect or a defect in the mounting method, then the bidder shall supply the agency with a report containing the date, a full explanation of the incident and corrective actions taken to prevent future ejections. Main cot/litter ejection's that occur during a collision indicates mechanical defects in the design of the restraining device or the

mounting method. Therefore, all bidder AMD standard 004 testing dated prior to the incident is deemed invalid, regardless of the expiration date of the original test.

AMD 005 - 12-VOLT DC ELECTRICAL SYSTEMS TEST: The 12-volt dc electrical system described herein shall be tested to the national truck equipment association, ambulance manufacturing division standard 005 - 12-volt dc electrical system s test. This test is valid for the test article vehicle only. The test shall be conducted on each ambulance. The results of the test shall be recorded on an electrical system performance sheet and shall be included with the delivery documents. This test shall be conducted by a qualified quality control electrician at the ambulance manufacturing plant.

Reliability and safety is this agency's first concern. The 12-volt electrical system must be function under all normal or adverse driving and operating conditions. Each electrical device, electrical component, wire, wire route and connection quality shall be tested for reliability as a "system" on each vehicle sold. If the bidder has experienced an electrical fire or an electrical failure resulting in a disabled ambulance going to an emergency call or during transportation, shall supply this agency with a report containing the date, a full explanation of the incident and corrective actions taken to prevent future electrical failures.

AMD 006 - PATIENT COMPARTMENT SOUND LEVEL TEST: The ambulance described herein shall meet or exceed the national truck equipment association ambulance manufacturing division standard 006 - patient compartment sound level test. The sound level in the driver or patient cabin shall be eighty decibels or less under the conditions described in AMD standard 006.

AMD 007 - PATIENT COMPARTMENT CARBON MONOXIDE LEVEL TEST: The ambulance described herein shall meet or exceed the national truck equipment association, ambulance manufacturing division standard 007 - patient compartment carbon monoxide level test. The patient and driver cabin shall be environmentally sealed from carbon monoxide gases that are emitted from internal combustion engines. The ambulance specified herein shall have safe carbon monoxide levels of ten parts per million or less while the vehicle is exposed to the conditions described in AMD standard 007.

AMD 008 - PATIENT COMPARTMENT GRAB RAIL STATIC LOAD TEST: The patient cabin grab rails shall be tested to the national truck equipment association, ambulance manufacturing division standard 008 - patient compartment grab rail static load test. The ceiling mounted grab rails shall be subject to a three-axis load of three hundred pounds. The ceiling mounted grab rail shall not come loose from the ceiling or permanently deform. All mounting fasteners shall be threaded into metal structure not less than .125 inches thick.

AMD 009 - 125-VOLT AC ELECTRICAL SYSTEMS TEST: The patient cabin shall be wired per the national truck equipment association, ambulance manufacturing division standard 009 - 125 -volt ac electrical systems test. The ambulance wiring shall comply with the national electric code in effect at the time of manufacture of the ambulance. The system specified herein shall be a 2-wire system with a ground. All outlets and 120-volt hard wired devices, on the ambulance, shall have ground fault interrupter protection.

AMD 010 - WATER SPRAY TEST: the ambulance specified herein shall be water spray tested for water leakage into the patient's and driver's cabins. The door to jamb seal, window installation and seals shall be tested against leakage per the national truck equipment association, ambulance manufacturing division standard 010 - water spray test. This test shall be conducted on each ambulance by the quality assurance department.

AMD 011 - EQUIPMENT TEMPERATURE TEST: The ambulance and equipment specified herein shall operate satisfactorily operate between 30 degrees and 125 degrees Fahrenheit per the national truck equipment association, ambulance manufacturing division standard 011 - equipment temperature test. This standard must be type certified by an independent testing laboratory on a like test model.

AMD 012 - INTERIOR CLIMATE CONTROL TEST: The ambulance and equipment specified herein shall be equipped with a HVAC (heating, ventilation, and air conditioning) system that will meet or exceed the performance criteria set forth in the national truck equipment association, ambulance manufacturing division standard 012 - interior climate control test. This standard must be type certified by an independent testing laboratory on a like test model.

AMD 013 - WEIGHT DISTRIBUTION GUIDELINES: The ambulance specified herein shall be weighed at the end of the ambulance manufacturer's production cycle to assure compliance with the national truck equipment association, ambulance manufacturing division standard 013 - weight distribution guidelines.

The vehicle specified herein must be weighed on a four-point scale that measures the weight imposed on each wheel. The side to side weight difference tolerance shall not exceed five percent (5%). The total weight imposed on the front axle shall not exceed the chassis manufacturer's gross axle weight rating minus three hundred pounds. The total weight imposed on the rear axle shall not exceed the chassis manufacturer's gross axle weight rating minus one thousand pounds. The aggregate total of all four points shall not exceed the gross vehicle weight rating minus eleven hundred pounds regardless of customer specified equipment.

AMD 014 - ENGINE COOLING SYSTEM TEST: The cooling system in the ambulance specified herein shall be tested to assure compliance with the national truck equipment association, ambulance manufacturing division standard 014 engine cooling system test. The vehicle specified herein must be tested at the end of the ambulance manufacturers manufacturing cycle to determine if the cooling system capacity is adequate to maintain safe engine operating temperature at ninety-five degrees, ambient temperature for one hour. Each ambulance shall be checked to assure a leak and trouble-free cooling system performance.

AMD 015 - AMBULANCE MAIN OXYGEN SYSTEM TEST: Each ambulance's main oxygen system shall be tested to assure compliance with the national truck equipment association, ambulance manufacturing division standard 015 ambulance main oxygen system test. The subject vehicle specified herein must be equipped with an oxygen system that can withstand a 150-psi charge of dry air or nitrogen for a period of four hours without a loss exceeding five pounds per square inch of pressure. The results of this test shall be posted inside the oxygen tank stowage compartment. A certificate shall be supplied, describing the test conditions, the initial test pressure, the final pressure (after four hours) and the name of the inspector who performed the test.

AMD 016 - PATIENT COMPARTMENT LIGHTING LEVEL TEST: The ambulance and equipment specified herein shall be equipped with patient compartment lighting that will meet or exceed the performance criteria set forth in the national truck equipment association, ambulance manufacturing division standard 016 - patient compartment lighting level test. This standard must be type certified by an independent testing laboratory on a like test model.

AMD 017 - ROAD TEST: The ambulance and equipment specified herein will meet or exceed the performance criteria set forth in the national truck equipment association, ambulance manufacturing division standard 017 - road test. This standard must be type certified by an independent testing laboratory on a like test model.

AMD 018 - REAR STEP AND BUMPER STATIC LOAD TEST: The rear step and bumper shall be type tested to the national truck equipment association, ambulance manufacturing division standard 018 - rear step and bumper static load test. This standard must be type certified by an independent testing laboratory on a like test model.

AMD 019 - MEASURING GUIDELINES: COMPARTMENTS AND CABINETS, The ambulance specified herein shall be in compliance with the national truck equipment association, ambulance manufacturing division standard 019 - measuring guidelines: compartments and cabinets.

AMD 020 - FLOOR DISTRIBUTED LOAD TEST: The ambulance specified herein shall be type tested to the national truck equipment association, ambulance manufacturing division standard 020 - floor distributed load test. This standard must be type certified by an independent testing laboratory on a like test model.

AMD 021 - ASPIRATOR SYSTEM TEST, PRIMARY PATIENT: Each ambulance's primary patient aspirator system shall be tested to assure compliance with the national truck equipment association, ambulance manufacturing division standard 021 - aspirator system test, primary patient.

AMD 022 - COLD ENGINE START TEST: The ambulance specified herein shall be type tested to the national truck equipment association, ambulance manufacturing division standard 022 - cold engine start test.

AMD 023 - SIREN PERFORMANCE TEST: The ambulance siren system shall be type tested to the national truck equipment association, ambulance manufacturing division standard 023 - siren performance test.

AMD 024 - PERIMETER ILLUMINATION TEST: The ambulance and equipment specified herein shall be equipped with perimeter lighting that will meet or exceed the performance criteria set forth in the national truck equipment association, ambulance manufacturing division standard 016 - perimeter illumination test. This standard must be type certified by an independent testing laboratory on a like test model.

AMD 025 - MEASURING GUIDELINES: OCCUPANT HEAD CLEARANCE ZONES: The ambulance specified herein shall be in compliance with the national truck equipment association, ambulance manufacturing division standard 025 - measuring guidelines: occupant head clearance zones.

Bidder Complies YES_____ NO_____

CRASHWORTHINESS: Safety is a primary objective for modular ambulance vehicles produced under this specification. In addition to compliance with design criteria incorporated herein, manufacturer shall also provide certified documentation to provide proof of crash worthiness of vehicle(s) proposed.

Crash worthiness of vehicle shall be demonstrated through a minimum of two actual crash tests of modular body ambulance under laboratory conditions. These crash tests will be similar in scope to testing performed by the national highway traffic safety administration and the Insurance Institute for Automobile Safety to verify the crash worthiness of passenger vehicles. An independent test laboratory accepted and utilized by The National Highway Traffic Safety Administration for their crash tests shall perform this testing and provide certification. Testing shall be performed and verified by SAE member engineers.

Test criteria shall be defined as a minimum of two actual high-speed impact crash tests between an ambulance and mid-size passenger vehicles. Collisions shall be into each side of manufacturer's

standard production modular ambulance body mounted on a chassis, struck by an actual bullet vehicle. Crash energy at impact shall be a minimum of 3,000 pounds at 42 miles per hour.

Reports from crash testing shall be certified by testing lab, and shall include the following minimum results:

- 1) The required six-point medic restraint system shall hold all attendants in their seats. there shall be no head contact with anything except head rests. There shall be no excessive excursion of the attendants in their seats regardless of which way they were facing.
- 2) The ambulance body structure shall remain intact after both impacts. Bending of body shall be localized to point of impact, and doors adjacent to the actual crash point shall continue to operate. There shall be no intrusion into the patient compartment.
- 3) The body mount and pucks shall remain intact as a result of the impacts. There shall be no visual damage to body mounts or floor structure.
- 4) All interior cabinetry and fixtures shall remain in place and undamaged.

This provision requires actual crash testing ff an ambulance by high-speed moving vehicles to validate safety and crash worthiness. Crash simulations, acceleration Testing, sled testing: Barrier testing or other theoretical tests are not sufficient to meet this requirement. Certified documentation from a qualified independent testing laboratory shall be provided with the bid in-order to validate compliance with this requirement.

Bidder Complies YES_____ NO_____

SPECIFICATION COMPLIANCE: The vendor shall inspect and test all systems, electrical loads, per current federal specification kkk-a-1822 section 4. Testing results shall be documented and displayed in the oxygen compartment and/or supplied with the delivery handbook.

QUALITY/COMPLIANCE ASSURANCE: A thorough quality/compliance inspection by this agency's employees or this agency's hired representative shall compare the ambulance to the specifications within 10 calendar days of written notice of vehicle completion by the successful bidder. The notice may be faxed, followed by phone contact. The customer reserves the right the bidder's dealer to conduct the inspection provided the dealer is authorized and qualified to correct quality/compliance issues at the dealer site.

Bidder Complies YES_____ NO_____

NON-COLLUSIVE BID CERTIFICATION: By submission of this bid response, the bidder and/or the bidder's authorized representatives, certify under penalty of perjury, that to the best of their knowledge and belief the following:

- A) The prices in the bid response have been arrived at independently without collusion, consultation, communication, or agreement for the purpose of restricting competition, as to any matter relating to such prices with any other bidder or with any competitor, and:
- B) Unless otherwise required by law, the prices which have been quoted in the bid response have not knowingly been disclosed by the bidder and will not knowingly be disclosed by the bidder, prior to the public bid opening, either directly or indirectly to any competitor, and:
- C) No attempt has been made or will be made by the bidder, for the purpose of restricting competition, to induce any person, partnership or corporation not to submit a bid response.

Bidder Complies YES_____ NO_____

DEBARMENT STATUS: By submission of this bid response, the bidder and/or its authorized representative, certify under penalty of perjury, that to the best of their knowledge and belief they are not currently debarred from submitting bids or bid on contracts by any agency within the home state of this agency, nor are they an agent of any person or entity that is currently debarred from submitting bids on contracts by any agency within the home state of this agency.

WARNING: this agency will not tolerate vendors who state compliance to specifications but deliver an incomplete product and/or sub-standard materials and workmanship. Vendors who have made delivery of such an ambulance without making every reasonable effort to remedy the defects found at the time of delivery or within the warranty period will be notified that they are debarred from submitting bids to this agency in the future. This agency will not waste valuable time (more than once) trying to recover legal costs and deal with lost in-service time of new apparatus, working with vendors who are unresponsive to the needs of this agency.

Bidder Complies YES_____ NO_____

CHASSIS

TYPE I AMBULANCE: The apparatus shall be a configuration a, 2-door, conventional cab and chassis with a transferable, modular, ambulance body.

Bidder Complies YES_____ NO_____

CHASSIS MAKE: The apparatus shall be mounted on a commercially available cab and chassis manufactured by Ford Motor Company. The chassis manufacturer shall be the vehicle's point of origin. The chassis shall be supplied by Ford as an incomplete vehicle to the successful ambulance manufacturer. The chassis supplied shall conform to all applicable Federal Motor Vehicle Safety Standards in force at the time of manufacture. A statement of conformity shall be supplied with the chassis in an "Incomplete Vehicle Manual".

CHASSIS MODEL: The apparatus shall be mounted on a 2022 or newer F-450, Regular cab, dual rear wheel, four-wheel drive chassis equipped as follows below.

Bidder Complies YES_____ NO_____

WHEELBASE: The wheelbase shall be 169.3 inches with a cab to axle dimension of 84". The wheelbase shall be factory supplied by the OEM Modified wheelbases made from chassis with shorter or longer wheelbases are not acceptable.

Bidder Complies YES_____ NO_____

OEM: The acronym OEM is Original Equipment Manufacturer. The OEM is the chassis manufacturer and the vehicles Maker and Origin.

TRIM LEVEL: The cab shall be equipped with an "XLT" Trim level with tilt steering wheel, cruise control, power windows and door locks. The front bumper and grill shall be accented with chrome. The OEM grille work shall remain OEM Aftermarket vacuum formed, proprietary grille work made by the ambulance manufacturer is not acceptable due to replacement part cost and lack of immediate availability.

Bidder Complies YES_____ NO_____

STANDARD SAFETY EQUIPMENT: The chassis shall be equipped with the following standard safety equipment.

- safety belt minder for front chassis cab seat belt passengers

- Advance Trac with RSC Roll Stability Control
- Driver and Passenger frontal and side airbag/curtain
- passenger side airbag deactivation switch
- SecuriLock Passive Anti-Theft System, Includes MyKey owner controls feature
- SOS Post-Crash Alert system
-

76Z Secure lock immobilizer. The correct and corresponding transponder coded key must be used to allow the engine to run. Absence of the correct key will prevent the engine from running.

Bidder Complies YES_____ NO_____

ENGINE: A V-8, turbo-charged diesel engine shall be provided with a minimum displacement of 6.7 liters (402 cu in). The engine output shall be 390 horsepower at 2,800 revolutions per minute and deliver 735-foot pounds of torque at 1,600 revolutions per minute. The compression ratio of the engine is 16.2:1 with a high-pressure common rail fuel injection system. Engine performance shall comply with or exceed the most current revision of KKK-A-1822.

Bidder Complies YES_____ NO_____

CHASSIS UNDERHOOD INSULATION: The XLT chassis model does not include under-hood insulation contoured to the chassis hood.

Bidder Complies YES_____ NO_____

TRANSMISSION: There shall be a ford, heavy duty torque shift, 10-speed, automatic transmission with overdrive provided. The transmission shall have selectable drive modes normal, tow/haul, eco and deep sand/snow.

Bidder Complies YES_____ NO_____

EXHAUST FILTER REGENERATION INHIBIT: The chassis shall be ordered with ford option 98r for operator commanded exhaust filter regeneration with active regeneration inhibit on the diesel engine power train. The purchasing agency should familiarize themselves with the owner's manual of the chassis prior to using this manual feature.

Bidder Complies YES_____ NO_____

CAB INTERIOR COLOR: The color of the cab interior shall be gray.

Bidder Complies YES_____ NO_____

TURN DIAMETER: The f-series chassis shall have 169.3-inch wheelbase.

Bidder Complies YES_____ NO_____

CAB SEATS: OEM high back, velour covered bucket type seats shall be provided in the cab. The seats shall manually adjust forward and aft. Seat base must be OEM. After market seats and/or bases are not acceptable due to violations regarding SRS (air bag) deployment geometry and ford QVM guidelines.

Bidder Complies YES_____ NO_____

OCCUPANT RESTRAINT SYSTEM: The front, forward facing cab seats shall be equipped with OEM installed three-point seat belts. The seat belt assemblies shall meet or exceed FMVSS. 208 and 209. The inside conversion panels shall not interfere with the swivel arc of the shoulder rings.

Bidder Complies YES_____ NO_____

SUPPLEMENTAL RESTRAINT SYSTEM: An OEM air bag shall be installed on the driver and passenger side. Permanent or quick release ambulance conversion components shall not interfere with air bag

deployment. The air bags must be completely operational. Modifications by the secondary manufacturer are not acceptable.

Bidder Complies YES_____ NO_____

GROSS VEHICLE WEIGHT RATING (GVWR): The GVWR of the chassis supplied shall be at least 16,500 pounds.

Bidder Complies YES_____ NO_____

FRONT AXLE WEIGHT RATING (FAWR): The FAWR shall be rated no less than 7,000 pounds.

Bidder Complies YES_____ NO_____

REAR AXLE WEIGHT RATING (RAWR): The RAWR shall be rated no less than 12,000 pounds.

Bidder Complies YES_____ NO_____

ALTERNATOR: There shall be dual OEM installed engine driven alternators with a gross output of 397-amp rating.

Bidder Complies YES_____ NO_____

BATTERIES: The chassis shall be fitted with Dual batteries OEM installed 750 cold cranking amp, 78-amp hour battery under the chassis hood.

Bidder Complies YES_____ NO_____

TRANSFER CASE: There shall be an aluminum closed coupled, part-time, 2-speed transfer case provided by the OEM. The case shall feature 3 modes of operation: 2-wheel drive high, 4-wheel drive high, 4-wheel drive low. The high range two wheel and four-wheel drive ratio shall be 1.00:1 and the low range shall be 2.72:1. The drive mode shall be manually selected by a rotary type electronic switch on the OEM dash. A 4 x 4 shift indicator shall illuminate on the dash when the transfer case is engaged in 4 x 4. After market or a divorced style transfer case is not acceptable.

Bidder Complies YES_____ NO_____

SPARE TIRE: One (1) spare tire and wheel assembly shall be supplied. When the tire is to be carried on the unit, the tire hold down shall meet current KKK-A-1822.

Bidder Complies YES_____ NO_____

SPARE TIRE STOWAGE LOCATION: The spare tire and wheel assembly will not be carried on the unit. The spare tire and all the related tools, if supplied by the OEM, shall be shipped loose with the completed vehicle.

Bidder Complies YES_____ NO_____

JACK AND SPARE TIRE TOOLS: The vehicle jack and tools associated with the spare tire and jack shall be installed behind the passenger's seat.

Bidder Complies YES_____ NO_____

WHEEL/RIM APPEARANCE: All four outside chassis wheels shall be covered in polished stainless steel wheel simulators. The wheel simulator design shall not effect tire and wheel balance when the vehicle is driven between zero and eighty miles per hour. The lugs shall be capped off with bright stainless steel, snap-on caps designed to cover wrench marks, normally remaining on the lug nuts.

Bidder Complies YES_____ NO_____

BRAKES: 4-wheel anti-lock, power assisted hydraulic brakes shall be supplied by the OEM The brakes shall be 4-wheel Disc type with Dual piston, Pin slider calipers. The front disc diameter shall be 14.53 inches in diameter and the rear disc shall be 15.55 inches in diameter. The parking brake shall be a foot operated, hand release independent mechanical brake, provided by the OEM.

Bidder Complies YES_____ NO_____

BRAKE BOOSTER / ANTI LOCK SYSTEM: The brake pedal effort shall be reduced by a hydro-boost power assist unit. The booster shall be installed on the fire wall and linked directly to the foot pedal. Hydraulic brake pressure shall route through a 3-channel, 4-Wheel anti-lock brake system that prevents wheel lock-up.

Bidder Complies YES_____ NO_____

INTERIOR UPGRADE PACKAGE: Ford interior upgrade package shall be ordered and supplied on the chassis. This package shall include:

- Cloth Headliner
- High trim door panels
- Ford option code 21A high back bucket seats
- Cloth sun visors
- Power Door locks
- Power Windows
- Insulation package

Bidder Complies YES_____ NO_____

FLOOR PEDALS: The chassis shall have OEM adjustable floor pedals, option 62M.

Bidder Complies YES_____ NO_____

DAYTIME RUNNING LIGHTS: Daytime running light option No 942 shall be supplied and installed by the OEM Both headlights shall come on with the ignition switch.

Bidder Complies YES_____ NO_____

CHASSIS CAB BRAKE LIGHT: There shall be a back of chassis cab high mount brake and courtesy light installed.

Bidder Complies YES_____ NO_____

SHOCK ABSORBERS: The chassis supplied shall be equipped with one shock absorber for each side of each axle. An OEM selected one and three eighth (1-3/8") inch gas type shock shall control vehicle spring oscillation and dampen road related jounce and harshness. Ambulance related shields, floor members or other devices shall not interfere with shock replacement.

Bidder Complies YES_____ NO_____

FRONT STABILIZER BAR: A computer selected; one inch diameter anti-sway bar shall be supplied. The bar shall regulate body shift and enhance drivability, handling and control. The solid torsion spring steel bar shall be attached to the vehicle frame utilizing natural rubber bushings and removable steel bushing housings. The ends of the bar shall be inserted into natural rubber bushings, located near the front wheels. Both axle attachment points shall be cast into the forged steel, I-beam front axle.

Bidder Complies YES_____ NO_____

FUEL TANK: The fuel capacity shall be at least 40 US gallons. The fuel range shall be at least 250 miles per KKK-A-1822.

Bidder Complies YES_____ NO_____

TIRES: All mounted, active tires shall be identical make, tread type, size and load range. For aforementioned GVWR the tires shall be LT225/70R19.5 load range F. A label with the recommended tire pressure shall be located above each wheel opening, unless specified otherwise by the purchaser. All tires shall be balanced per KKK-A-1822 3.6.12.

Bidder Complies YES_____ NO_____

AMBULANCE PREPARATON PACKAGE: The chassis provided shall be equipped with an ambulance preparation package designed and installed by the OEM The 47L allows operator commanded regeneration down to 30% DPF capacity. The 47A had to have at least 70% DPF capacity to do a manual regeneration. The low-DEF fluid will not cause the vehicles speed limiting or forced idle. It will still give you the warning lights, chimes and message. The 47L is a Federal Emissions compliant package. It is not certified in California or the Green States. California has declared to NTEA/AMD that they do not regulate emergency vehicles. The package shall be designed to hold up to the demands and duty cycles inherent with Emergency Medical Vehicles.

Bidder Complies YES_____ NO_____

ALTERNATOR - CHARGING SYSTEM: Two alternators shall be supplied and installed by the OEM The alternators shall be as supplied by Ford under the 47L/A Ford Ambulance Prep option. Both alternators shall be controlled by the vehicle's on-board computer. The combined output of the alternators shall be 377 amps at ideal conditions. The ambulance manufacturer shall not modify the OEM computer's functional control of the alternators. The alternators' output cable, originally connected directly to the positive post of the under-hood battery, shall be rerouted to a 3/8" diameter, solid brass junction post. A 2/O positive battery cable shall reconnect the alternators to the batteries from the junction post. The ambulance load cable shall connect under the hood to the aforementioned junction post.

Bidder Complies YES_____ NO_____

THROTTLE CONTROL: There shall be a set of diodes and resistors connected to OEM provided wiring to activate the High Idle function when conditions are met. When the vehicle is in Park, parking brake engaged, and the coolant has reached 140 degrees Fahrenheit the high idle system shall activate during a low power indication.

Bidder Complies YES_____ NO_____

CAB STEREO: An OEM Ford AM/FM/MP3 in dash radio and four cab mounted speakers shall be included with the chassis. The radio shall feature an eight-inch digital capacitive display with swipe capable technology. The radio and entertainment system shall feature a built in modem per FORD OEM design with up to 10 user connectivity per compatible devices. The radio shall provide for a clock time display, Bluetooth connectivity smart device mirror integration and retained accessory power. The steering wheel shall have radio controls integrated and easily usable.

Bidder Complies YES_____ NO_____

CHASSIS VOICE CONTROL SYNCH3 (FORD ONLY): The chassis manufacturer shall include a FORD SYNCH3 option which will allow for greater safety of the vehicle driver. The driver shall be able to voice control connect to multiple wireless systems. The driver of the vehicle shall refer to the owner's manual for details of operation. The chassis radio and information system shall feature an eight-inch center stack touch screen with audio control and compass, and eight inch productivity screen in the instrument cluster. Two USB charging ports shall be OEM included. Bluetooth connectivity to the available applications are available for a connected compatible device. An information cluster screen is located in the chassis to assist the driver.

Bidder Complies YES_____ NO_____

MIRRORS: The chassis shall be outfitted with dual OEM, power adjusted mirror glass, manually telescoping trailer tow black mirrors. The mirrors shall connect to the chassis cab doors at the forward, lower corner of the cab door window. Both mirrors shall feature a bi-directional break-away function to permit folding the mirror heads against body in close quarters. The mirrors shall be seven inches wide by eight inches high and flat on both right and left sides. The mirror shall feature heated surfaces for the main mirror and the convex spotter mirror. The mirror heads shall

incorporate forward facing integrated clearance lamps on the outer edge with minimal halo turn signal functions.

Bidder Complies YES_____ NO_____

REAR KNEELING SUSPENSION: A Liquid Spring rear hydraulic strut suspension shall be installed in lieu of the standard rear OEM single stage leaf springs. The suspension company shall be QS 9000 and ISO 9001 certified for excellence. The liquid suspension shall be rated at 12,000 pounds GAWR and installed per Liquid Spring Directions. Suspension Installation instructions and drawings shall be followed. All guidelines regarding chassis and axle capacity ratings as published by Ford Motor Corporation shall be adhered to.

MECHANICAL SUSPENSION COMPONENTS: The control arms shall be connected to a replacement front hanger that features upper and lower control arm pivot points and a connection point for a heavy duty sway bar. Both Liquid Spring struts shall be positioned directly aft of the axle and outboard of frame rails. The designed ride height shall maintain original suspension's drive-line geometry.

TRACKING BAR: The suspension shall utilize a lateral control rod (tracking bar) to maintain side to side axle position related to the chassis frame. Wear shoes, mounted to the sides of the frame rails are not acceptable.

HYDRAULIC SYSTEM: All hydraulic lines, fittings, reservoirs and valves shall be protected against "stone pecking". Abrasion covers, such as nylon convolute loom over the lines are required. The entire assembled system shall be tested for leaks at every fitting connection point.

MECHANICAL QUALITY ASSURANCE: All fasteners related to the suspension assembly are considered critical. All fasteners shall be tightened to the manufacturer's recommended torque by the primary installation mechanic. A secondary mechanic shall "put a wrench" and re-torque ALL of the fasteners and then spray a contrasting color of paint onto the heads and nuts of each fastener.

SUSPENSION JOUNCE STUDY: A suspension jounce clearance study shall be performed throughout the full range of suspension travel to ensure adequate clearance of suspension, frame and brake components. Test results shall be documented and supplied in the owner's manual.

Bidder Complies YES_____ NO_____

KNEELING FEATURE ENABLE: The rear suspension shall kneel when the triggering device is activated AND an enable switch, located in the cab console is activated.

Bidder Complies YES_____ NO_____

KNEELING FEATURE ACTIVATION: The kneeling feature shall activate in PARK position only. The kneeling feature shall NOT activate in any forward or reverse gear. The above rear suspension shall kneel when the trailing rear access door is opened.

Bidder Complies YES_____ NO_____

VEHICLE EXHAUST TERMINATION POINT: The exhaust system routing shall remain unmodified, and the termination point shall remain after the rear axle on the right side.

Bidder Complies YES_____ NO_____

REAR STABILIZER BAR: The rear sway bar shall remain OEM.

Bidder Complies YES_____ NO_____

TIRE VALVE EXTENDERS: One pair of tire valve extenders shall be supplied and installed for each inside rear wheel. The tire valve extenders shall permit the user to check tire pressure and fill the

inside rear tires without removing the outer tire. The extenders shall have a braided stainless steel outer jacket to resist abrasions and cuts. The filler end shall be supported by a valve bracket.

Bidder Complies YES_____ NO_____

MODULE CONSTRUCTION - GENERAL

SERVICE INTENT: The ambulance body shall be all aluminum. The body sheet shall be reinforced with structural members designed to resist deflection and hold up to extreme ambulance service per the latest revision of federal specification KKK-A-1822F.

BODY MEMBER ALLOY: The side, front and rear sheet shall be derived from .125", 5052-H32 aluminum sheet. The roof sheet shall be one (1) piece, .090", from roof rail to roof rail. The side structure and structural shapes shall be extruded of 6105-T6 aluminum.

STRUCTURAL INTEGRITY: The body shall be capable of providing impact, deformation and penetration resistance in the event of a collision. The body structure shall be capable of passing a standalone static load test on a type-tested body. The test shall be conducted in accordance to AMD-001 except the test weight shall be a minimum of 55,000 pounds. The same unit shall be subjected to the same test with the body turned on its side. A complete copy of the testing documents with photos must be supplied upon bid review if requested by this agency. Non-compliant bids will be rejected.

WELD QUALITY: All welds within the modular body shall meet American Welding Society codes for structural and sheet welding.

CREVICE PREPARATION: All skin and extrusion surfaces destined to be mated together, shall be primed with epoxy, etching primer prior to assembly. All overlapping extrusion to skin surfaces shall be bedded with a two-part acrylic high strength bonding adhesive.

SIDE STRUCTURAL MEMBERS: The sheet edges will be fit into slots designed within a proprietary, double hollow, corner post extrusion in addition to the two-part acrylic bonding agent. The sheet will be MIG welded and structurally bonded to the extrusion. Double-hollow designed corner post extrusions shall be used to weld side and end assemblies together. Horizontally oriented, adjoining structural box tubes shall be welded to the corner post with a minimum 50% surface weld. The intermediate structural members of the side grid shall be two by two inch 6105-T6 aluminum, architectural box tubing. All entry and compartment door adjacent members shall be one quarter inch, two by two-inch proprietary extruded shape. The main structure shall surround the compartment openings and provide intermediate skin support. The intermediate structure spacing shall have a nominal dimension of twelve inches. All grid structure shall be welded together with a minimum of 75% of available mating surface. The side skin shall be bonded to the structural grid using 1.75 inch wide, VHB (Very High Bond) adhesive tape. The edges of the tube that touch the skin will be sealed with Bostik Brand, Simson ISR 70-03 Construction Adhesive.

SIDE IMPACT RAILS: There shall be four side impact rails, located in the upper and lower sections of the side walls. They shall consist of 6105-T6 aluminum, that is a solid one-half inch thick by four-inch plate on the curbside and one-half by four-inch plates on the street side that are continuously MIG welded or Huck structurally fastened to the structural grid. Since this is a safety item, no exceptions will be accepted.

Bidder Complies YES_____ NO_____

SEAT BELT ANCHORAGE: Occupant seat belts shall be drilled and tapped through one-half by four inch plate on the curbside and one-half by four-inch plates on the street side that are continuously

MIG welded to the structural grid. Since this is a safety item, no exceptions will be accepted.

Bidder Complies YES_____ NO_____

SIDE SHEET: The side sheet shall be .125 thick, 5052-H32 aluminum. The side sheet compartment opening cut outs shall be cut with CNC controlled, gantry mounted plasma or high-speed routing equipment. The door opening shall be cut to allow for the skin to be molded into the jamb opening to create a crevice free jamb with a smooth paint finish. The machine formed skin shall return into the body at least 3/4" to meet the jamb extrusion. This method will encourage square openings to receive the door assemblies and maintain critical structural locations. The door jamb shall have a full structure frame behind the jamb skin return. It shall not rely strictly on the skin for the compartment jamb. Pre-determined ventilation louvers shall be formed into the body sheet, where specified. Bodies that do not incorporate formed louvers have the potential for additional corrosion points and are not preferred by this agency.

Bidder Complies YES_____ NO_____

SEAMLESS DOOR JAMBS: The door jambs of the module shall be seamless. A seamless door jamb exterior is required to minimize corrosion. Extruded type exposed door jambs do not meet this specification. The skin shall completely conceal the door-jamb from view. The only visible seams on the body sheet shall be at the corner posts. The skin shall extend .688 inch below the skirt rail extrusion to a drip edge to keep moisture from collecting underneath where the skin meets the skirt rail extrusion.

Bidder Complies YES_____ NO_____

CORNER POST EXTRUSION: The corners of the modular body shall be made from an extruded aluminum structure that has an alloy of 6105-T6. The corner post extrusion shall be 3.25 x 3.25-inch with a 2-inch- radius on the outer corner. The corner post extrusion shall have an internal web member that runs on a 45-degree angle to the front and side of the modular body. Where the internal web meets the exterior extrusion wall the internal web shall flair into a .125-inch radius giving a .25-inch wall thickness at the exterior wall of the extrusion. There shall be a .75-inch flange on each side of the corner post extrusion that is a side skin receiver. The side skin receiver shall be funnel shaped to allow the exterior side skin to fully seat into the corner post extrusion. The interior walls of the corner post extrusion shall be .125-inch thick, and they shall incorporate a 45-degree weld bevel on the interior corners.

Bidder Complies YES_____ NO_____

REAR SILL EXTRUSIONS: The rear body and floor substructure shall be constructed of a dual proprietary aluminum extrusion with mating joints. The lower floor extrusion is a combination continuous extrusion with an incorporated L mating surface. The lower door extrusion is a multi-chamber construction with matching radius corner and surfaces to the floor sill. This combination of extrusion and joint structure provides for strong joint strengths, and continuous contact surface between the floor sill and the outer-body door extrusion.

Bidder Complies YES_____ NO_____

FRONT AND SIDE WALL GUSSET PLATES: The front wall and side wall structural members shall have additional support with a fully welded gusset system that shall be made of 5052-H32 aluminum plate, .25-inch-thick by four by four-inch.

Bidder Complies YES_____ NO_____

REAR AND SIDE WALL GUSSET PLATES: The rear wall and side wall structural members shall have additional support with a fully welded gusset system that shall be made of 5052-H32 aluminum plate, one quarter inch thick by four by four inch.

Bidder Complies YES_____ NO_____

ROOF RAIL EXTRUSIONS: The roof corners of the modular body shall be made from an extruded aluminum structure that has an alloy of 6105-T6. The roof rail extrusion shall be 4.55 x 3.5 inch with a 2-inch radius on the outer corner. A full-length drip rail shall be incorporated into the roof rail corner post extrusion, drip rails at the top of the modular body that are not inclusive of the roof rail extrusion do not meet the intent of the specification and are deemed non-compliant to this specification. The roof rail extrusion shall have an internal web member that runs on a 45-degree angle to the front and side of the modular body. Where the internal web meets the exterior extrusion wall the internal web shall flair into a .125-inch radius giving a .25-inch wall thickness at the exterior wall of the extrusion. There shall be a .75-inch-flange on the lower side of the roof rail extrusion that is a side skin receiver. The side skin receiver shall be funnel shaped to allow the exterior side skin to fully seat into the roof rail extrusion. There shall be a .75 x .125-inch recess into the roof side of the extrusion for locating the roof sheeting. This recess shall have a 45-degree weld bevel. The interior wall of the roof rail extrusion that is in-board of the side skin funnel shall be 2-inch-wide so that they line up with the exterior side wall. The interior wall of the roof rail extrusion that is in-board of the roof sheeting recess shall be 2.25-inch-wide so that they line up with the 2.25-inch roof bows. The interior walls of the roof rail extrusion shall be .125-inch-thick, and they shall incorporate a 45-degree weld bevel on the interior corners.

Bidder Complies YES_____ NO_____

ROOF SHEET: The four (4) edges of the sheet shall be continuously welded to the roof rail extrusion to prevent leaks. All perimeter welds shall be ground smooth and worked smooth prior to the overall body paint and finish. Non-fully welded roof sheets to the roof rail extrusions do not meet the intent of this specification and are deemed non-compliance to this specification.

Bidder Complies YES_____ NO_____

ROOF BOWS: The roof sheet shall be supported by full width .125-inch-thick x 2 x 2.25-inch architectural box tubing. The roof bows shall be located on twelve-inch centers. The roof bows shall be MIG welded to the roof rail extrusions with no less than four and one-half inches of continuous weld per end. The roof sheet shall be bonded to the roof bows with VHB (Very High Bond) adhesive tape.

Bidder Complies YES_____ NO_____

LATERAL ROOF SUPPORTS: If this agency requires ducted ceiling HVAC, additional structural support will be added as a result of the 2 inch ducted heat and A/C delivery system .2 x 2-inch three-sided extruded channel with two sides being .125-inch-thick and the bottom surface for fastener acceptance to be .160-inch shall be full length of the body.

Bidder Complies YES_____ NO_____

ROOF CORNERS: The roof rail extrusions shall be welded together along the roof bow mating walls at the corners. In addition, the outer surfaces of the roof rail extrusions shall be 100% continuously TIG welded to cast aluminum corner castings. The castings shall have internal mating flanges that extend horizontally inside the upper roof rail extrusion and vertically down the corner post extrusions. The corner roof castings shall have accommodations for number six nylon inserts to retain corner cap marker combination warning lights when they are specified. The nylon inserts shall provide isolation of the retaining screw of the light from the casting materials.

Bidder Complies YES_____ NO_____

FLOOR MEMBERS: Floor structures shall be 6105-T6 aluminum, 2.000 by 2.500-inch proprietary hollow section architectural box tubing aluminum. This proprietary shape tubing

allows for half-inch plate to be recess to which floor mounted items can be securely connected. Each member shall have a defined bevel built into the extrusion die to allow for full weld penetration on the edge of the extrusions.

Bidder Complies YES_____ NO_____

FLOOR HORIZONTAL GUSSET PLATES: The floor member to side wall fully welded horizontal gusset system shall be made of 5052-H32 aluminum plate, four (4) by four (4) inch triangles. A minimum of 12 gussets shall be located horizontally connecting cross members to longitudinal main center members at each main cross member site.

Bidder Complies YES_____ NO_____

FULL WIDTH CROSS MEMBERS: The module floor shall provide core support for the side assemblies and shall incorporate a minimum of four (4) full body width floor members. The full width floor members shall connect to and support the side wall assemblies. Each member shall be made of 6105-T6 aluminum. The front floor tube is to be a minimum of 3.000 x 2.000 x .250 inch-thick 6105-T6 aluminum tube which is fully MIG welded into the front corner post at each side of the vehicle. On top of the tube is to be a minimum .188 thick 5052 aluminum front sill running full width of the body. One of the members located just forward and/or rear of the rear wheel housing shall be 2.000 by 2.500-inch proprietary hollow section architectural box tubing. The last floor cross-member shall be a 2.375 x 3.188 6105-T6 aluminum proprietary shape proof tube on the rear wall which is fully MIG welded into the rear corner posts at each side of the vehicle. This tube is butted up and welded to a 2.000 x 1.000 x .125 inch-thick 6105-T6 tube which is also fully MIG welded to the rear corner post. A minimum of eight (8) total 6-inch vertical gussets, (1/4) inch thick will be installed to reinforce two (2) at each cross member and sidewall tubes directly fore and aft of the axle.

Bidder Complies YES_____ NO_____

FLOOR SYSTEM CANTILEVER BEAMS: There shall be cantilever floor beams used at intermittent body points running from the opposite main interior wall beam to the opposite exterior wall at the location between exterior compartments. The use of cantilever beams increases the strength of the overall floor system and support to the compartments.

Bidder Complies YES_____ NO_____

WHEELWELLS: There shall be formed wheel well housings installed into the module body to provide sufficient clearance for the rear axle movement based on the chassis jounce study and suspension choice selected. The wheel well shall be formed of smooth aluminum and secured to the floor tube structure system. The wheel well shape shall be multi-angular with vertical riser and flat top to provide the most efficient use of space inside of the module, while providing the required jounce clearance underneath for the chassis tire movement. Wheel wells that are radius shaped are not acceptable to this agency, as they are unnecessarily tall and inefficient in space usage.

Bidder Complies YES_____ NO_____

WATERTIGHT PATIENT CABIN: The sub floor shall be shielded from moisture. An aluminum sub sheet shall be sealed to the floor structure with silicone sealant. Additional aluminum plates shall be intermittent welded between compartments, wheel well liners, step wells and fuel filler housings. All of the areas shall be thoroughly sealed from one to the other, creating a sealed patient cabin from the outside. Extrusion hollows shall be filled with expandable foam sealant to prevent fumes and moisture from entering.

Bidder Complies YES_____ NO_____

DOOR CONSTRUCTION

DOOR SKIN: No welded seams are allowed, only one piece formed corners. The door skin shall be .090 inch-thick, 5052-H32 aluminum sheet formed on all four sides utilizing an ACF Multi-flex Corner Former Model MF 25 to create a crevice free surface for best paint adhesion and corrosion resistance. The formed edges shall not have elongation cracks due to forming and shall maintain material thickness uniformly over the entire sheet. The formed edges uniformly round off seamless for better paint adhesion and aesthetic appeal that does not require cutting and welding in the corners.

Bidder Complies YES_____ NO_____

DOOR FRAMING: The door frame shall reinforce the perimeter of the skin pan. The extrusion shall incorporate a T-slot to receive an extruded, hollow, dual durometer closed cell UV protected TPV gaskets with relief holes for even compression for a proper and complete seal from the door to the door jamb. The gasket corners shall be welded without using adhesives for bonding. The door frame extrusion shall also add torsion resistance to the door assembly. The door jamb extrusion and frame extrusion shall be cut 45 degree on each corner. Each of the four corners shall incorporate a keyway and spline that is designed to drive into each corner and maintain a perfect 90-degree angle prior to welding. The door castings shall include gusset plates for additional support for the door construction. The door frame shall also incorporate a clearance way for UNF threaded blind fasteners for the door panels. The door panel shall not rest on the body of the blind fasteners.

Bidder Complies YES_____ NO_____

FINAL DOOR ASSEMBLY: The door skin shall be bonded to the frame assembly with an adhesive sealant in addition to intermittent welding. For entry door's additional horizontal structure shall be added to maintain door skin flatness as well as penetration resistance in the event of a collision. The horizontal members are extruded J-channel, 0.150 inch-thick. A minimum of two horizontal members shall be welded in. A vertically oriented 0.150-inch-thick formed hat-channel shall be welded to the webs of both horizontal channels for additional buckling resistance. Compartment doors shall have a reinforcement system of horizontal or horizontal/vertical structure added to maintain skin flatness and impact resistance.

ENTRY DOOR WINDOW(S) OPENINGS: The entry door(s) shall incorporate recessed areas that are stamped into the outer door skin to allow for a flush window appearance and shall not protrude with a lip on the outer door skin of the modular body.

DOOR PANELS: The inside entry door panels shall be made of .080-inch-thick aluminum plate and shall be finished per these specifications later in this document. The center panel shall be removable for easy lock service/lubrication. The inside of the compartment door panels shall be made of .080-inch-thick polished aluminum diamond plate. The edges of the door panel shall be recessed into the door frame extrusion. The panels shall be fastened to the door frame with stainless steel, #10-32 UNF machine screws threaded into aircraft quality blind fasteners. Each fastener shall have an internal tooth lock washer to preclude loosening.

Bidder Complies YES_____ NO_____

DOOR JAMB: The door jamb shall accommodate rigid fastening of compartment door hinges. The jamb shall include a hollow cell that shall conceal wiring for the non-mechanical door switch. The door jamb frame shall be cut 45 degree on each corner from the door edge corner, each of the four corners shall consist of a keyway and spline that is designed to drive into each corner and maintain a perfect 90-degree angle prior to welding. Additionally, the jamb shall be continuously MIG welded on the inside and the outside corners. A seamless door jamb exterior is required to minimize corrosion - extruded type door jambs do not meet

this specification. The skin shall completely conceal the doorjamb from view. "No Exterior Door Extrusions Allowed".

Bidder Complies YES_____ NO_____

HINGE: All doors shall have stainless steel, continuous, piano hinge. The pin diameter shall be .250 and staked into place to prevent drifting out of the hinge leaf. The knuckle lengths shall be one inch.

DOOR HINGE BOLTS: The hinge attachment bolts shall be one quarter inch diameter by one-inch-long stainless-steel type TT (Thread Rolling Screws) hex head bolts with SermaGard protective coatings. Each bolt shall be treated with the aluminum filled basecoat/resin-bonded fluoropolymer topcoat system. The SermaGard 1105/1280 protective coated bolt system is designed to provide outstanding salt and dissimilar metal corrosion protection versus bolts treated with pastes and liquids. The SermaGard coating provides UV weathering resistance while protecting the aluminum tube structures and stainless-steel hinges from dissimilar metal contacts. The SermaGard provides a sacrificial corrosion protection. Body manufacturers that do not use bolts treated with SermaGard 1105/1280 are providing substandard protection from corrosion and are not acceptable. Thread cutting screws to attach exterior compartment doors or hinges to the body are not acceptable.

Bidder Complies YES_____ NO_____

LATCHES: The latches shall meet FMVSS 206. All latches shall be two-stage, rotary- type. The latches shall be through bolted to the door frame extrusion. All entry doors shall have two rotary latches per door. To assure uniform latch timing and functional door reliability, only straight, one-quarter (1/4) inch diameter rods shall connect the latches to the handle. All double hung compartment doors shall have two rotary latches per door.

Bidder Complies YES_____ NO_____

NADER PINS: All Nader pins shall be headed to prevent the door(s) from opening under impact. They shall be hex headed Grade-8 fully adjustable with a 5/16" thick knurled stainless-steel retainer plate to keep the Nader pin from moving out of setting after adjusted. The opening in the door jamb extrusion shall be large enough to allow full adjustment with the Nader pin washer covering the hole. Manufacturers that use Nader pins without knurled retainers are not acceptable to this agency as they will require more frequent readjustment.

Bidder Complies YES_____ NO_____

MOUNTING

MOUNTING SYSTEM: The body shall be 100% isolated from chassis vibrations. Welding and drilling additional holes in the flanges of the frame shall not be done anywhere between the axles and the outer most spring shackles. Twelve ¼ thick out-rigger mounts shall be through bolted through the web (vertical wall of the frame) of the frame rail. New Holes drilled in the frame shall leave at least 1 of steel from the edge of the new hole and the edge an existing hole. Each mount shall utilize three grade 8, 5/8 diameter, flanged head bolts with flanged, locking nuts. Each mount shall accommodate a natural rubber vibration isolator and support for the body's mounting sill. All mounting sills shall be made of one inch thick by three-inch-wide solid aluminum flat bar. A grade L-9 seven sixteenth inch diameter by four-inch-long hex-head bolt shall be used to bolt the sill down at each isolator site.

Bidder Complies YES_____ NO_____

MODULE CONFIGURATION

OVERALL LENGTH: The overall length of the vehicle shall not exceed twenty-four feet, five inches (293 inches) per current revision of Federal Specification KKK-A-1822. The departure angle shall meet or exceed current revision of Federal Specification KKK-A-1822.

Bidder Complies YES_____ NO_____

MODULE LENGTH: The module length shall be at least one hundred fifty-four inches.

Bidder Complies YES_____ NO_____

MODULE WIDTH: The module width shall comply with current revision of Federal Specification KKK-A-1822. The module shall be ninety-five inches wide, excluding lights and accessories.

Bidder Complies YES_____ NO_____

MODULE HEAD ROOM: The module shall not be less than seventy-two inches actual measured headroom. The measurement shall be taken from the patient compartment floor to the ceiling panels.

Bidder Complies YES_____ NO_____

MODULE EXTERIOR HINGES: There shall be installed stainless steel hinges with standard mill finish for all exterior compartments and entry doors on the module. These hinges shall feature slots for mounting and adjustment of the doors. The finished module paint and special mounting bolts with Serpa coatings shall assist in deterring the stainless-steel hinges from dissimilar metal corrosion.

Bidder Complies YES_____ NO_____

DOOR CHECK: The compartment door(s) in excess of 13" pass through width shall be equipped with a door check (hold open) device. All vertically hinged doors in excess of 13" pass through width shall have a gas operated bi-directional spring shock door check. Door check brackets shall be drilled and tapped through a minimum of 3/8" material to preclude coming loose.

Bidder Complies YES_____ NO_____

DOOR SWING: The compartment door checks shall be installed to allow the door to open ninety to 100 degrees (90 up to 100) from the fully closed position.

Bidder Complies YES_____ NO_____

COMPARTMENT CONSTRUCTION

MATERIALS: Unless specified otherwise, all exterior compartment walls and backs shall be constructed of .100 polished aluminum diamond plate. All compartment floors shall be formed of .125 aluminum sheet. Compartments for generators, oxygen, and backboards will have .250 compartment floors. All compartment ceilings shall be formed of .090 aluminum sheet. The ceilings and floors shall form around the sides and back to provide an overlapping joint. The floor and ceiling surfaces shall be double action (DA) sanded to 180 grit. The floors and ceilings are bonded to the walls and back and intermittent welded on six (6) inch centers.

Bidder Complies YES_____ NO_____

DRAIN HOLES: Drain holes shall be provided on the bottom of the compartments. Each hole shall be baffled to prevent splash water from entering the compartment.

Bidder Complies YES_____ NO_____

COMPARTMENT FLOOR CONFIGURATION: This compartment floor shall be a sweep out type floor. The compartment floor shall be flush with the lower door jamb to facilitate compartment floor cleaning. The edge of the compartment floor shall be continuously welded to the lower door jamb.

Heat generated from welding shall not distort the straightness or flatness of the jamb or compartment floor. The weld quality must be aesthetically uniform.

Bidder Complies YES_____ NO_____

COMPARTMENT FLOOR THICNESS: The compartment floor shall be .125-inch-thick aluminum of single layer.

Bidder Complies YES_____ NO_____

VENTILATION: There shall be a hole in the compartment below floor line approximately 5-3/8" wide x 2-9/32" tall that will accept a specially designed baffled vent. The baffles shall have a stainless-steel spring that allow for only one way operation. They allow air to escape out of the compartment when the door is closed, but not for air to come back into the compartment to keep dirt and dust out of the compartment interior. Engineering shall determine the amount of these vents required by the volume of space in the compartment.

Bidder Complies YES_____ NO_____

CURBSIDE ACCESS DOOR: The curbside side access door shall be at least 78-7/8" high by 31" wide measured at the door jamb opening.

JAMB PROTECTION: At the curbside side, module entry door, a full width, formed, stainless steel jamb protection plate shall be provided to prevent heavy traffic from chipping the paint.

Bidder Complies YES_____ NO_____

DOOR CHECK: The curbside entry door shall be equipped with a door check (hold open) device. All vertically hinged doors in excess of 13" pass through width shall have a gas operated bi-directional spring shock door check. Door check brackets shall be drilled and tapped through a minimum of 3/8" material to preclude coming loose.

Bidder Complies YES_____ NO_____

DOOR SWING: The compartment door checks shall be installed to allow the door to open ninety to 100 degrees (90 up to 100) from the fully closed position.

Bidder Complies YES_____ NO_____

CURB SIDE ACCESS DOOR LOCATION: The module side entry door shall be located on the curbside of the module, just rearward of the ALS cabinet to provide efficient egress into the module.

Bidder Complies YES_____ NO_____

STEP WELL: A curbside entry door shall feature a double step "step well" to assist in patient cabin egress. The step shall have a tread dimension of not less than 10 inches. The riser dimension shall not exceed nine and one-half inches, measured from the step tread to the floor of the patient cabin. A right-angled trim, made of bright aluminum diamond plate, shall be formed over the flooring material and wrap around the 3-sided perimeter of the step well. Step well material shall be 0.100 thick, Polished aluminum diamond plate. The step well shall be illuminated. The step well shall meet or exceed the current revision of Federal specification KKK-A-1822.

Bidder Complies YES_____ NO_____

STEP WELL ILLUMINATION: A 3" clear interior light shall illuminate the curbside step well per the current revision of Federal specification KKK-A-1822.

Bidder Complies YES_____ NO_____

LEFT FRONT COMPARTMENT (M-1): This compartment shall be located in the left front corner of the modular body. The minimum compartment dimensions shall be 82.8" high x 18.6" wide x 19.4" deep.

Bidder Complies YES_____ NO_____

COMPARTMENT CONSTRUCTION

MATERIALS: Unless specified otherwise, all exterior compartment walls and backs shall be constructed of .100 polished aluminum diamond plate. All compartment floors shall be formed of .125 aluminum sheet. Compartments for generators, oxygen, and backboards will have .250 compartment floors. All compartment ceilings shall be formed of .090 aluminum sheet. The ceilings and floors shall form around the sides and back to provide an overlapping joint. The floor and ceiling surfaces shall be double action (DA) sanded to 180 grit. The floors and ceilings are bonded to the walls and back and intermittent welded on six (6) inch centers.

Bidder Complies YES_____ NO_____

DRAIN HOLES: Drain holes shall be provided on the bottom of the compartments. Each hole shall be baffled to prevent splash water from entering the compartment.

Bidder Complies YES_____ NO_____

COMPARTMENT DOOR PANEL: The inside door panel of this compartment shall be diamond plate.

Bidder Complies YES_____ NO_____

COMPARTMENT FINISH: Unless specified otherwise, all exterior compartment walls and backs shall be constructed of .100 polished aluminum diamond plate.

Bidder Complies YES_____ NO_____

VENTILATION: There shall be three sets of six louver punches on the outside and inside door panel to properly ventilate the electrical components located in the above-mentioned compartment.

Bidder Complies YES_____ NO_____

COMPARTMENT FLOOR CONFIGURATION: This compartment floor shall be a sweep out type floor. The compartment floor shall be flush with the lower door jamb to facilitate compartment floor cleaning. The edge of the compartment floor shall be continuously welded to the lower door jamb. Heat generated from welding shall not distort the straightness or flatness of the jamb or compartment floor. The weld quality must be aesthetically uniform.

Bidder Complies YES_____ NO_____

COMPARTMENT FLOOR THICNESS: The compartment floor shall be .125-inch-thick aluminum of single layer.

Bidder Complies YES_____ NO_____

COMPARTMENT DOOR: A single, forward hinged, compartment door shall be set for this compartment. The door shall have a single handle and two rotary latches.

Bidder Complies YES_____ NO_____

DOOR CHECK: The compartment door(s) in excess of 13" pass through width shall be equipped with a door check (hold open) device. All vertically hinged doors in excess of 13" pass through width shall have a gas operated bi-directional spring shock door check. Door check brackets shall be drilled and tapped through a minimum of 3/8" material to preclude coming loose.

Bidder Complies YES_____ NO_____

DOOR SWING: The compartment door checks shall be installed to allow the door to open ninety to 100 degrees (90 up to 100) from the fully closed position.

Bidder Complies YES_____ NO_____

COMPARTMENT LIGHT: (1) One light shall be mounted in the ceiling of the "M-1" compartment. The light shall be surface mount.

Bidder Complies YES_____ NO_____

COMPARTMENT LIGHT BRACKET: Where applicable a 45-degree bracket shall be used to mount the compartment light for beneficial illumination.

Bidder Complies YES_____ NO_____

LEFT FRONT MIDDLE COMPARTMENT (M-2): This compartment is located adjacent and rearward to the left front compartment. The minimum compartment dimensions shall be 34.5" High x 29.875" Wide x 19.4" Deep.

Bidder Complies YES_____ NO_____

COMPARTMENT CONSTRUCTION

MATERIALS: Unless specified otherwise, all exterior compartment walls and backs shall be constructed of .100 polished aluminum diamond plate. All compartment floors shall be formed of .125 aluminum sheet. Compartments for generators, oxygen, and backboards will have .250 compartment floors. All compartment ceilings shall be formed of .090 aluminum sheet. The ceilings and floors shall form around the sides and back to provide an overlapping joint. The floor and ceiling surfaces shall be double action (DA) sanded to 180 grit. The floors and ceilings are bonded to the walls and back and intermittent welded on six (6) inch centers.

Bidder Complies YES_____ NO_____

DRAIN HOLES: Drain holes shall be provided on the bottom of the compartments. Each hole shall be baffled to prevent splash water from entering the compartment.

Bidder Complies YES_____ NO_____

COMPARTMENT DOOR PANEL: The inside door panel of this compartment shall be diamond plate.

Bidder Complies YES_____ NO_____

COMPARTMENT FINISH: Unless specified otherwise, all exterior compartment walls and backs shall be constructed of .100 polished aluminum diamond plate.

Bidder Complies YES_____ NO_____

VENTILATION: All compartments, made from aluminum sheet, shall have at least eight louvers of ventilation to the outside below floor line. The oxygen cylinder and backboard compartments shall also be louvered through the inner and outer door panel up high with at least nine (9) square inches of free-vented area.

Bidder Complies YES_____ NO_____

COMPARTMENT FLOOR CONFIGURATION: This compartment floor shall be a sweep out type floor. The compartment floor shall be flush with the lower door jamb to facilitate compartment floor cleaning. The edge of the compartment floor shall be continuously welded to the lower door jamb. Heat generated from welding shall not distort the straightness or flatness of the jamb or compartment floor. The weld quality must be aesthetically uniform.

Bidder Complies YES_____ NO_____

COMPARTMENT FLOOR THICNESS: The compartment floor shall be .125-inch-thick aluminum of single layer.

Bidder Complies YES_____ NO_____

ADJUSTABLE SHELF: A standard duty aluminum adjustable shelf shall be provided. The shelf shall be formed of .125 (1/8") thick aluminum, with 2 inches upward turned lips on all four sides. The shelf shall be mounted on Unistrut infinitely adjustable, aluminum extruded, heavy duty shelf track. Incrementally adjustable, non-aluminum shelf track is not acceptable.

Bidder Complies YES_____ NO_____

SHELF BRACKET: Each above exterior adjustable shelf shall include four (4) self gusseted .157" thick shelf brackets that will allow for easy adjustment up and down for each shelf. Each bracket shall be secured to the shelf by carriage head bolts on the top of the shelf and hex head bolts to secure them to the shelf tracking material in the compartments. This will guard against shelf deformation in the compartments when the shelves are secured in place.

Bidder Complies YES_____ NO_____

COMPARTMENT DOOR: A single, forward hinged, compartment door shall be set for this compartment. The door shall have a single handle and one rotary latch.

Bidder Complies YES_____ NO_____

DOOR CHECK: The compartment door(s) in excess of 13" pass through width shall be equipped with a door check (hold open) device. All vertically hinged doors in excess of 13" pass through width shall have a gas operated bi-directional spring shock door check. Door check brackets shall be drilled and tapped through a minimum of 3/8" material to preclude coming loose.

Bidder Complies YES_____ NO_____

DOOR SWING: The compartment door checks shall be installed to allow the door to open ninety to 100 degrees (90 up to 100) from the fully closed position.

Bidder Complies YES_____ NO_____

ADJUSTABLE SHELF: A standard duty aluminum adjustable shelf shall be provided. The shelf shall be formed of .125 (1/8") thick aluminum, with 2 inch upward turned lips on all four sides. The shelf shall be mounted on Unistrut infinitely adjustable, aluminum extruded, heavy duty shelf track. Incrementally adjustable, non-aluminum shelf track is not acceptable.

Bidder Complies YES_____ NO_____

SHELF BRACKET: Each above exterior adjustable shelf shall include four (4) self gusseted .157" thick shelf brackets that will allow for easy adjustment up and down for each shelf. Each bracket shall be secured to the shelf by carriage head bolts on the top of the shelf and hex head bolts to secure them to the shelf tracking material in the compartments. This will guard against shelf deformation in the compartments when the shelves are secured in place.

Bidder Complies YES_____ NO_____

COMPARTMENT LIGHT: (1) One light shall be mounted in the ceiling of the "M-1" compartment. The light shall be surface mount.

Bidder Complies YES_____ NO_____

COMPARTMENT LIGHT BRACKET: Where applicable a 45-degree bracket shall be used to mount the compartment light for beneficial illumination.

Bidder Complies YES_____ NO_____

CONDUIT No 1: An empty one- and one-half inch diameter conduit expressly designed to add wires after vehicle delivery by the end user or his/her authorized agent shall be supplied and installed. The conduit shall have semi-rigid, nonconductive liner that is free of inside ridges that can bind on the wire harness being pulled through the conduit. The outer jacket shall be a non-conductive, spiraled rigid coil designed to maintain the original shape of the liner, throughout the length of the

conduit run.

Bidder Complies YES_____ NO_____

ORINATION POINT: The aforementioned conduit shall originate in the left front middle (M-2), exterior compartment.

TERMINATION POINT: The aforementioned conduit shall terminate in the patient cabin behind the main action area control panel.

Bidder Complies YES_____ NO_____

CONDUIT No 2: An empty one- and one-half inch diameter conduit expressly designed to add wires after vehicle delivery by the end user or his/her authorized agent shall be supplied and installed. The conduit shall have semi-rigid, nonconductive liner that is free of inside ridges that can bind on the wire harness being pulled through the conduit. The outer jacket shall be a non-conductive, spiraled rigid coil designed to maintain the original shape of the liner, throughout the length of the conduit run. A pull wire shall be installed into the conduit to aid the purchasing agency in future installation of equipment.

Bidder Complies YES_____ NO_____

ORINATION POINT: The aforementioned conduit shall originate inside the main electrical cabinet.

TERMINATION POINT: The aforementioned coaxial cable shall terminate in the cab behind the driver's seat.

Bidder Complies YES_____ NO_____

LEFT REAR COMPARTMENT (M-3): This compartment shall be located in the left rear corner of the body. The minimum compartment dimensions shall be 61.5" High x 34" Wide x 19.4" deep.

Bidder Complies YES_____ NO_____

COMPARTMENT CONSTRUCTION

MATERIALS: Unless specified otherwise, all exterior compartment walls and backs shall be constructed of .100 polished aluminum diamond plate. All compartment floors shall be formed of .125 aluminum sheet. Compartments for generators, oxygen, and backboards will have .250 compartment floors. All compartment ceilings shall be formed of .090 aluminum sheet. The ceilings and floors shall form around the sides and back to provide an overlapping joint. The floor and ceiling surfaces shall be double action (DA) sanded to 180 grit. The floors and ceilings are bonded to the walls and back and intermittent welded on six (6) inch centers.

Bidder Complies YES_____ NO_____

DRAIN HOLES: Drain holes shall be provided on the bottom of the compartments. Each hole shall be baffled to prevent splash water from entering the compartment.

Bidder Complies YES_____ NO_____

COMPARTMENT DOOR PANEL: The inside door panel of this compartment shall be diamond plate.

Bidder Complies YES_____ NO_____

COMPARTMENT FINISH: Unless specified otherwise, all exterior compartment walls and backs shall be constructed of .100 polished aluminum diamond plate.

Bidder Complies YES_____ NO_____

COMPARTMENT FLOOR CONFIGURATION: This compartment floor shall be a sweep out type floor. The compartment floor shall be flush with the lower door jamb to facilitate compartment floor

cleaning. The edge of the compartment floor shall be continuously welded to the lower door jamb. Heat generated from welding shall not distort the straightness or flatness of the jamb or compartment floor. The weld quality must be aesthetically uniform.

Bidder Complies YES_____ NO_____

COMPARTMENT FLOOR THICNESS: The compartment floor shall be .125 inch thick aluminum of single layer.

Bidder Complies YES_____ NO_____

COMPARTMENT DOOR: A single, forward hinged, compartment door shall be set for this compartment. The door shall have a single handle and two rotary latches.

Bidder Complies YES_____ NO_____

DOOR CHECK: The compartment door(s) in excess of 13" pass through width shall be equipped with a door check (hold open) device. All vertically hinged doors in excess of 13" pass through width shall have a gas operated bi-directional spring shock door check. Door check brackets shall be drilled and tapped through a minimum of 3/8" material to preclude coming loose.

Bidder Complies YES_____ NO_____

DOOR SWING: The compartment door checks shall be installed to allow the door to open ninety to 100 degrees (90 up to 100) from the fully closed position.

Bidder Complies YES_____ NO_____

VERTICAL DIVIDER: Located in the "M_" compartment shall be semi-rigid fixed divider shall be formed of 5052-H32 aluminum sheet. The divider shall be full height of the compartment by fourteen inches (14") deep: measured from the back of the compartment. The exposed edge shall be covered with automotive edge trim.

Bidder Complies YES_____ NO_____

COMPARTMENT LIGHT: (1) One light shall be mounted in the ceiling of the "M-3" compartment. The light shall be surface mount and shall utilize 921 bulb.

Bidder Complies YES_____ NO_____

RIGHT REAR COMPARTMENT (M-5): This compartment shall be located in the right rear corner of the body. The minimum compartment dimensions shall be 82.8" High x 20" Wide x 21" Deep.

Bidder Complies YES_____ NO_____

COMPARTMENT CONSTRUCTION

MATERIALS: Unless specified otherwise, all exterior compartment walls and backs shall be constructed of .100 polished aluminum diamond plate. All compartment floors shall be formed of .125 aluminum sheet. Compartments for generators, oxygen, and backboards will have .250 compartment floors. All compartment ceilings shall be formed of .090 aluminum sheet. The ceilings and floors shall form around the sides and back to provide an overlapping joint. The floor and ceiling surfaces shall be double action (DA) sanded to 180 grit. The floors and ceilings are bonded to the walls and back and intermittent welded on six (6) inch centers.

Bidder Complies YES_____ NO_____

DRAIN HOLES: Drain holes shall be provided on the bottom of the compartments. Each hole shall be baffled to prevent splash water from entering the compartment.

Bidder Complies YES_____ NO_____

COMPARTMENT DOOR PANEL: The inside door panel of this compartment shall be diamond plate.

Bidder Complies YES_____ NO_____

COMPARTMENT FINISH: Unless specified otherwise, all exterior compartment walls and backs shall be constructed of .100 polished aluminum diamond plate.

Bidder Complies YES_____ NO_____

CEILING VENTILATION: Specified compartments shall have a hat channel at the ceiling level. The hat channel shall run to no closer than 1" from the compartment side walls to allow for air exchange. Hidden from view, shall be two to three, (4") holes above the hat channel to exhaust the compartment air when the door is closed to allow it to close with minimal effort.

Bidder Complies YES_____ NO_____

VENTILATION: There shall be three sets of six louver punches on the outside and inside door panel to properly ventilate the electrical components located in the above mentioned compartment.

Bidder Complies YES_____ NO_____

COMPARTMENT FLOOR CONFIGURATION: This compartment floor shall be a sweep out type floor. The compartment floor shall be flush with the lower door jamb to facilitate compartment floor cleaning. The edge of the compartment floor shall be continuously welded to the lower door jamb. Heat generated from welding shall not distort the straightness or flatness of the jamb or compartment floor. The weld quality must be aesthetically uniform.

Bidder Complies YES_____ NO_____

COMPARTMENT FLOOR THICNESS: The compartment floor shall be .125 inch thick aluminum of single layer.

Bidder Complies YES_____ NO_____

COMPARTMENT DOOR: A single, forward hinged, compartment door shall be set for this compartment. The door shall have a single handle and two rotary latches.

Bidder Complies YES_____ NO_____

DOOR CHECK: The compartment door(s) in excess of 13" pass through width shall be equipped with a door check (hold open) device. All vertically hinged doors in excess of 13" pass through width shall have a gas operated bi-directional spring shock door check. Door check brackets shall be drilled and tapped through a minimum of 3/8" material to preclude coming loose.

Bidder Complies YES_____ NO_____

DOOR SWING: The compartment door checks shall be installed to allow the door to open ninety to 100 degrees (90 up to 100) from the fully closed position.

Bidder Complies YES_____ NO_____

FIXED DIVIDERS: One semi-rigid fixed dividers shall be formed of 5052-H32 aluminum sheet. The divider shall be sixty inches (60") high by fourteen inches (14") deep: measured from the track: and have a two-inch return flange formed along the sixty-inch edge for mounting. All corners on the divider and shelf shall be rounded or chamfered. One fixed, horizontally oriented shelf shall be formed of 5052-H34 aluminum sheet. The shelf shall be fastened to the right wall of the compartment and to the divider. The shelf shall be eight inches (8") wide by fourteen inches (14") deep. The shelf shall not have a lip and shall be positioned 42" from the compartment floor. The exposed edges of the divider and shelf shall be covered with automotive edge trim. Two full width, horizontally oriented, Unistrut C-channel tracks shall be fastened to the back wall of the aforementioned compartment.

Bidder Complies YES_____ NO_____

DIVIDER MATERIAL: The aforementioned divider(s) shall be made of 0.125 thick 5052-H32 aluminum sheet.

Bidder Complies YES_____ NO_____

RETAINER STRAP: One two-inch-wide webbed restraint strap shall be supplied in the compartment. The strap shall employ a metal buckle system with a push button release. The strap is to be fastened to the compartment walls with a two-inch footman's loop. The fastener is not to be fastened through the webbing material.

Bidder Complies YES_____ NO_____

RETAINER STRAP: One two-inch-wide webbed restraint strap shall be supplied in the compartment. The strap shall employ a metal buckle system with a push button release. The strap is to be fastened to the compartment walls with a two-inch footman's loop. The fastener is not to be fastened through the webbing material.

Bidder Complies YES_____ NO_____

COMPARTMENT LIGHT: (1) One light shall be mounted in the ceiling of the "M-1" compartment. The light shall be surface mount.

Bidder Complies YES_____ NO_____

COMPARTMENT LIGHT BRACKET: Where applicable a 45 degree bracket shall be used to mount the compartment light for beneficial illumination.

Bidder Complies YES_____ NO_____

RIGHT REAR FORWARD COMPARTMENT (M-6): This compartment shall be located just forward of the right rear compartment aft of the rear wheel opening. The minimum compartment dimensions shall be 20.25" High x 17.25" Wide x 19.4" Deep.

Bidder Complies YES_____ NO_____

COMPARTMENT CONSTRUCTION

MATERIALS: Unless specified otherwise, all exterior compartment walls and backs shall be constructed of .100 polished aluminum diamond plate. All compartment floors shall be formed of .125 aluminum sheet. Compartments for generators, oxygen, and backboards will have .250 compartment floors. All compartment ceilings shall be formed of .090 aluminum sheet. The ceilings and floors shall form around the sides and back to provide an overlapping joint. The floor and ceiling surfaces shall be double action (DA) sanded to 180 grit. The floors and ceilings are bonded to the walls and back and intermittent welded on six (6) inch centers.

Bidder Complies YES_____ NO_____

DRAIN HOLES: Drain holes shall be provided on the bottom of the compartments. Each hole shall be baffled to prevent splash water from entering the compartment.

Bidder Complies YES_____ NO_____

COMPARTMENT DOOR PANEL: The inside door panel of this compartment shall be diamond plate.

Bidder Complies YES_____ NO_____

COMPARTMENT FINISH: Unless specified otherwise, all exterior compartment walls and backs shall be constructed of .100 polished aluminum diamond plate.

Bidder Complies YES_____ NO_____

COMPARTMENT FLOOR CONFIGURATION: This compartment floor shall be a sweep out type floor. The compartment floor shall be flush with the lower door jamb to facilitate compartment floor cleaning. The edge of the compartment floor shall be continuously welded to the lower door jamb. Heat generated from welding shall not distort the straightness or flatness of the jamb or compartment floor. The weld quality must be aesthetically uniform.

Bidder Complies YES_____ NO_____

COMPARTMENT FLOOR THICNESS: The compartment floor shall be .125-inch-thick aluminum of single layer.

Bidder Complies YES_____ NO_____

COMPARTMENT DOOR: A single, forward hinged, compartment door shall be set for this compartment. The door shall have a single handle and one rotary latch.

Bidder Complies YES_____ NO_____

DOOR CHECK: The compartment door(s) in excess of 13" pass through width shall be equipped with a door check (hold open) device. All vertically hinged doors in excess of 13" pass through width shall have a gas operated bi-directional spring shock door check. Door check brackets shall be drilled and tapped through a minimum of 3/8" material to preclude coming loose.

Bidder Complies YES_____ NO_____

DOOR SWING: The compartment door checks shall be installed to allow the door to open ninety to 100 degrees (90 up to 100) from the fully closed position.

Bidder Complies YES_____ NO_____

ADJUSTABLE SHELF: A standard duty aluminum adjustable shelf shall be provided. The shelf shall be formed of .125 (1/8") thick aluminum, with 2 inch upward turned lips on all four sides. The shelf shall be mounted on Unistrut tracking, infinitely adjustable, aluminum extruded, heavy duty shelf track. Incrementally adjustable, non-aluminum shelf track is not acceptable.

Bidder Complies YES_____ NO_____

SHELF BRACKET: Each above exterior adjustable shelf shall include four (4) self-gusseted .157" thick shelf brackets that will allow for easy adjustment up and down for each shelf. Each bracket shall be secured to the shelf by carriage head bolts on the top of the shelf and hex head bolts to secure them to the shelf tracking material in the compartments. This will guard against shelf deformation in the compartments when the shelves are secured in place.

Bidder Complies YES_____ NO_____

COMPARTMENT LIGHT: (1) One light shall be mounted in the ceiling of the "M-1" compartment. The light shall be surface mount.

Bidder Complies YES_____ NO_____

COMPARTMENT LIGHT BRACKET: Where applicable a 45-degree bracket shall be used to mount the compartment light for beneficial illumination.

Bidder Complies YES_____ NO_____

RIGHT FRONT COMPARTMENT (M-7): This compartment shall be located in the right front corner of the module body. The minimum compartment dimensions shall be 67.5" High by 15.3" Wide. The compartment door shall provide direct outside access into the right front advanced life support equipment storage area and a 12" high stowage area, under floor level. The under-floor compartment shall be 12" high by 19.4" Deep.

Bidder Complies YES_____ NO_____

COMPARTMENT DOOR: A single, forward hinged, compartment door shall be set for this compartment. The door shall have a single handle and two rotary latches.

Bidder Complies YES_____ NO_____

DOOR CHECK: The compartment door(s) in excess of 13" pass through width shall be equipped with a door check (hold open) device. All vertically hinged doors in excess of 13" pass through width shall have a gas operated bi-directional spring shock door check. Door check brackets shall be drilled and tapped through a minimum of 3/8" material to preclude coming loose.

Bidder Complies YES_____ NO_____

DOOR SWING: The compartment door checks shall be installed to allow the door to open ninety to 100 degrees (90 up to 100) from the fully closed position.

Bidder Complies YES_____ NO_____

COMPARTMENT LIGHT: (1) One light shall be mounted in the ceiling of the "M-1" compartment. The light shall be surface mount.

Bidder Complies YES_____ NO_____

COMPARTMENT LIGHT BRACKET: Where applicable a 45 degree bracket shall be used to mount the compartment light for beneficial illumination.

Bidder Complies YES_____ NO_____

REAR ACCESS DOORS: The rear of the module shall be equipped with double, hinged patient compartment access doors. The doors shall be centered on the body and align with the patient compartment aisle space. The doors shall measure 46 3/4 inches wide by 60 5/8" high, jamb to jamb.

REAR ACCESS DOOR JAMB: At the rear access doors, a full width, formed, stainless steel jamb protection plate shall be provided to prevent the cot frames from chipping the paint. The stainless-steel protection package shall start from under the kick plate and follow the contour of the jamb extrusion, cover the end of the sub-floor and cover the last four inches of the vinyl floor covering.

Bidder Complies YES_____ NO_____

TALK THROUGH CAB TO MODULE WINDOW: A 14" inch high by 19" inch wide access from the module to the cab shall be provided. Sliding polycarbonate doors shall close off the access window. The cab shall NOT be rigidly fastened to the modular body. A flexible, Accordion shaped, closed cell rubber bellows, custom made for the opening shall be provided to tie the cab to the module. One joint in the bellows is acceptable and shall be located on the bottom of the opening. The joint shall be completely vulcanized. The window provided shall meet or exceed current Federal specification KKK-A-1822.

Bidder Complies YES_____ NO_____

BODY DROP: The Curbside of the modular body ahead of the rear wheels skirt shall be 6" lower than the street side and behind the rear wheels. This body drop will allow the curbside entry step to be lower to ground level making it easier to enter the curbside entry door and meet the requirement of KKK-A-1822 latest revision.

Bidder Complies YES_____ NO_____

DOOR JAMB SILL PROTECTION: On the compartments specified below, the paint on the bottom horizontal portion of the door jamb shall be protected by a twenty (20) gauge minimum stainless steel protection plate. This plate shall originate at the toe of the door jamb lip (where it mates against the skin), then forms around the lower flat surface, then forms up across the gasket mating

surface and finally forms across the inner jamb surface and terminates where the compartment meets the jamb.

Bidder Complies YES_____ NO_____
Left Front Compartment Bottom Door Jamb.

Bidder Complies YES_____ NO_____
Left Front Middle Compartment Bottom Door Jamb.

Bidder Complies YES_____ NO_____
Left Rear Compartment Bottom Door Jamb.

Bidder Complies YES_____ NO_____
Right Rear Compartment Bottom Door Jamb.

Bidder Complies YES_____ NO_____
Right Rear Forward Compartment Bottom Door Jamb.

Bidder Complies YES_____ NO_____
Right Front "ALS" Compartment Bottom Door Jamb.

Bidder Complies YES_____ NO_____
Battery Compartment Bottom Door Jamb.

Bidder Complies YES_____ NO_____
FUEL FILLER AND HOUSING: The filler neck supplied by the OEM shall be used. The filler neck shall be vented and be diameter indexed to accommodate a FUEL pump nozzle. The fuel filler neck shall be bolted to a cast aluminum fill housing. The filler housing shall be an open design with a bright polished mounting flange. The housing configuration and filler installation shall comply with the OEM Body Builders Layout Book. The fuel filler neck shall be grounded directly to the frame rail to prevent static electric charges from igniting the fuel vapors during refueling. The fuel filler cap shall be supplied by the OEM. The cap shall be attached to the filler housing with a lanyard. The filler cap shall incorporate an over-tighten protection device that ratchets, when the preset cap torque is reached.

Bidder Complies YES_____ NO_____
UREA FILLER AND HOUSING: The filler neck shall be a Cast Products Inc. model FG5301-1. The filler neck shall be vented and be diameter indexed to accommodate the DEF nozzle. The fuel filler neck shall be bolted to the cast aluminum fill housing. The housing bezel shall be bright and polished. The housing configuration and filler installation shall comply with the OEM's Body Builders Layout Book. The filler cap shall be supplied by the OEM.

Bidder Complies YES_____ NO_____
BODY PROTECTION AND BRIGHT WORK

WIRE/HOSE COVER: The area between the back of the cab and the front of the module shall have a .100 aluminum diamond plate cover, attached to the frame rails, to protect any hoses and/ or wires routed in that location. The cover shall be mounted to close-off the area with a finished appearance.

Bidder Complies YES_____ NO_____

WIND DEFLECTOR: A short aluminum diamond plate wind deflector shall be installed directly above the pass thru cab connection. There shall be a small up turned lip on the backside of the part to assist in re-routing water runoff. The part shall have a gap between the outer edge and the module body.

Bidder Complies YES_____ NO_____

FRAMING: The rear step bumper shall exceed the current revision of KKK-A-1822. The bumper shall be framed in with ¼ x 2 x 4 aluminum 6063-T6 rectangular tubing. The bumper shall be bolted directly to the chassis frame. In addition, the top of the bumper shall be mounted below the body skirt-line, so that minor collisions do not damage the body. The bumper will collapse under the body. For the stated reasons, there shall be no exceptions to this feature.

OUTER PONTOONS: The outer bumper ends (pontoons) shall be covered in .100 polished aluminum diamond plate. The outer corners shall be angled 50 degrees. Each pontoon cover shall be through bolted to the bumper frame with stainless steel, pan-head, Phillips's head, ¼-20 bolts and Nylock nuts.

DEPTH OF BUMPER: The rear bumper shall protrude from the rear surface of the module body to the rearward most metal surface by at least nine- and one-half inches (9-1/2") and not more than ten inches (10").

Bidder Complies YES_____ NO_____

CENTER STEP: A flip up step shall be provided to allow closer access to the patient cabin floor. The step shall be as wide as the rear access door jamb. The step shall have aggressive traction. The step shall have a red/white reflexite reflective strip across the flip up step. A stainless-steel piano hinge shall have a staked in, ¼" diameter pin, one-inch knuckles and one Type-F ¼" through bolt every four inches.

Bidder Complies YES_____ NO_____

FENDERS: The rear fender shall be bright aluminum. The fender shall be isolated and mounted to the wheel opening with thin membrane, double side tape. In addition to the tape, 100% nylon bolt and nuts shall hold the fender to the body.

Bidder Complies YES_____ NO_____

SKIRT RAILS: The entire skirt-line of the body, forward and aft on the rear wheels shall have formed .188" diamond plate skirt rails to protect the body. Each skirt rail shall meet current Federal Specification KKK-A-1822. Each rail shall be chamfered 45 degrees at both ends. The rails shall be fastened through the bottom of the rail into the bottom of the modular body. The rails shall not cut into the paint. They shall be mounted through nylon isolators in such a manner that they are spaced off the body.

Bidder Complies YES_____ NO_____

REAR KICK PLATE: The rear kick plate shall be made of 0.100-inch-thick Polished aluminum diamond plate and run from corner post to corner post. The height shall be from the skirt-line of the body to the bottom door jamb under the rear access doors.

Bidder Complies YES_____ NO_____

RECOVERY EYES: Two vertically oriented, heavy duty chrome tow eyes with a one-inch threaded stud shall be through bolted to a one half inch thick steel plate that is continuously welded to the end of the OEM Frame. The recovery eyes shall be recessed into the kick panel so that the tangency of the eyes are co-planer with OR set back up to one inch. The recovery (Tow) eyes shall not be trip hazard to personnel entering and leaving the rear access doors.

Bidder Complies YES_____ NO_____

ACCESS HOLES: Access to the recovery eyes shall be made through a finished access hole through the Diamond plate "Kick panel" under the rear doors. The access holes shall be at least five inches in diameter and the edges of the holes shall be covered in automotive edge trim. The trim must be bonded to the kick plate in addition to the clamp on ribbing that shall be built into the trim.

Bidder Complies YES_____ NO_____

RECESSED TAG AREA: The kick plate shall feature a centered and illuminated recessed area to mount a standard U.S. six inch high by twelve-inch-wide license plate. The recessed area must be located as specified below and aesthetically TIG Welded around the perimeter of the opening. Threaded inserts and bolts to install the tag shall be installed and provided.

Bidder Complies YES_____ NO_____

RECESSED TAG AREA LOCATION: The tag area shall be centered in the kick plate.

Bidder Complies YES_____ NO_____

TAG LIGHT: The tag area shall be LED illuminated with the park light circuit.

Bidder Complies YES_____ NO_____

BODY CORNER POST PROTECTION: The lowest twenty-four inches (24") of the corner post extrusions shall be protected against stones and road debris. The corner post guards shall be formed of .080 thick polished aluminum diamond plate, contour fit to the corner post extrusions and riveted into place. A bead of silver colored, silicone sealant shall be applied across the top edge of the guards. The bottom of edge of the guard shall be left unsealed to promote moisture drainage.

Bidder Complies YES_____ NO_____

FRONT OF BODY: The front of the body shall have skirt-line protection plates made of .080 aluminum diamond plate. The corner posts shall have form fit diamond plate protection height matched to the frontal plates. The height of the protection is twenty-four inches up from the body skirt line.

Bidder Complies YES_____ NO_____

RUNNING BOARDS: **Custom Running Boards/Pre Build Meeting

Bidder Complies YES_____ NO_____

MUD DEFLECTION: The front chassis fender shall feature an ABS fender extension that shall assist in deflecting mud, snow and other debris, rendering a mud flap unnecessary.

Bidder Complies YES_____ NO_____

REAR MUD FLAPS: Mud flaps behind both sets of rear tires shall be supplied and installed. The mud flaps shall be 1/4" thick natural rubber material. Each mud flap shall be sandwiched between the wheel well liner and a torque distribution plate. The torque distribution plate shall be at least .100 thick aluminum plate. Each mud flap shall be through bolted to the wheel well liner with at least three (3) one-quarter inch (1/4") diameter stainless steel bolt.

Bidder Complies YES_____ NO_____

COURTESY STEP LIGHTS: There shall be a pair of courtesy step lights consisting of a Whelen style 20C0CDRCR 4" chrome flange mounted to the front of the modular body on the lower body diamond plate stone guards. The lights shall be illuminated with the door ajar circuit for the cab doors.

Bidder Complies YES_____ NO_____

REAR ACCESS DOOR CHECKS: Rear access doors shall open at least 150 degrees. The door checks shall be 2 piece, heavy duty, cast aluminum, grabber type. The door shall have a ½ round stock loop that plunges into a positive rubber/Cast socket. Each half of the door checks shall be insulated from the skin with a rubber gasket. Each door check half shall be rigidly mounted. Skin flex is not acceptable. One door check positioned at the top and bottom of each rear access door is required.

Bidder Complies YES_____ NO_____

CORROSION: The anti-electrolysis procedure for any holes that are drilled for application of materials is to be as follows, After the hole is drilled, the opening(s) are to be treated with Tactile 517 prior to installation of any fasteners to guard against any future corrosion.

EXTERIOR FASTENERS: All screw sites require a replaceable nylon insert for the fastener to thread into to isolate the dissimilar metals. Each hole shall be treated with an Electrolysis Corrosion Control compound (Tactile 517) prior to installation of the nylon inserts. All exterior screws shall be stainless steel.

Bidder Complies YES_____ NO_____

BODY CORNER CAPS: The front and rear upper body corners shall include a cavity built into the aluminum body that shall not sacrifice the body integrity.

Bidder Complies YES_____ NO_____

FRONT CORNER ICC LIGHTS: The front body corner caps shall include DOT approved compliant light fixtures with clear lenses. The lenses shall house ICC fixtures that include amber LED's to be mounted to the front and front corners. There shall also be additional LED lights that alternate red and clear within the light to act as additional warning lights.

Bidder Complies YES_____ NO_____

FRONT ICC LIGHTS: Clearance lights shall be provided per FMVSS 108. The lights shall illuminate the height of the vehicle, define the vehicle center line. Three (amber) lights shall be provided on the front of the module and be populated with at least two LED's.

Bidder Complies YES_____ NO_____

REAR CORNER ICC LIGHTS: The rear body corner caps shall include DOT approved compliant light fixtures with clear lenses. The lenses shall house ICC fixtures that include red LEDs to the rear and rear corners. There shall also be additional LED lights that alternate red and amber within the light to act as additional warning lights.

Bidder Complies YES_____ NO_____

REAR ICC LIGHTS: Clearance lights shall be provided per FMVSS 108. The lights shall illuminate the height of the vehicle and define the vehicle centerline. Three red lights shall be provided on the rear of the module and be populated with at least two LED's.

Bidder Complies YES_____ NO_____

CORNER CAP WARNING LIGHT SWITCHING: The above-mentioned corner cap LED lights shall be wired to activate in Primary Only.

Bidder Complies YES_____ NO_____

SIDE MARKER LIGHTS: Side marker lights shall be Kinequip Model 112401RD (Red) and shall flash alternately with the rear turn lights. All lights shall be LED.

Bidder Complies YES_____ NO_____

STOP/TAILLIGHT: The stop/taillight fixtures on the rear of the body shall be Whelen Brand series M6, Light Emitting Diode to operate as both tail and stop modes and shall be red when illuminated.

Bidder Complies YES_____ NO_____

TURN SIGNAL LIGHT: The turn signal light fixtures on the rear of the body shall be Whelen Brand series M6, Light Emitting Diode to operate as left and right turn signal lights and shall be amber arrow when illuminated.

Bidder Complies YES_____ NO_____

BACK UP SIGNAL LIGHT: The backup signal light fixtures on the rear of the body shall be Whelen Brand series M6, Light Emitting Diode to operate as left and right back up signal lights and shall be clear when illuminated.

Bidder Complies YES_____ NO_____

LIGHT HEAD FLANGE: Whelen bright, chrome (Flange), on the above "M" Series light head(s).

Bidder Complies YES_____ NO_____

UNDERBODY GROUND LIGHTING: Under the body of the ambulance shall be a total of six (6), bezel sealed lights mounted downward to shine on the ground to warn anything underneath the unit of vehicle movement. The lights shall be wired to activate with a switch in the console and only in Park/Neutral position.

Bidder Complies YES_____ NO_____

THIRD BRAKE LIGHT: A third brake light shall be located centered above the rear access doors. The light/lens shall measure at least 15 square inches. The light is to be a Whelen model M6 RED LED.

Bidder Complies YES_____ NO_____

THIRD BRAKE LIGHT: When the brake is applied the light will steady burn.

Bidder Complies YES_____ NO_____

EXTERIOR FLOOD and LOAD LIGHTING:

LEFT SCENE LIGHTS: Two scene lights shall be provided on the left side of the module. The lights shall be Whelen LED-M9 series. A chrome flange shall be provided with each light. The scene light group shall meet or exceed the present revision of the Federal specification KKK-A-1822.

Bidder Complies YES_____ NO_____

BRIGHT CHROME-LIKE FLANGES: The M9 scene light group shall each have bright chrome trim flanges.

Bidder Complies YES_____ NO_____

SCENE LIGHT SWITCHING: The scene lights shall come on with two separate rocker switches labeled Right Flood and Left Flood, located in the center cab console controlled by the master switch. The right (curb side) scene lights shall also come on when the side entry door is opened.

Bidder Complies YES_____ NO_____

RIGHT SCENE LIGHTS: Two scene lights shall be provided on the right side of the module. The lights shall be Whelen LED-M9 series. The lights shall include a chrome flange. The scene light group shall meet or exceed current revision of the Federal specification KKK-A-1822.

Bidder Complies YES_____ NO_____

BRIGHT CHROME-LIKE FLANGES: The M9 scene light group shall each have bright chrome trim flanges.

Bidder Complies YES_____ NO_____

REAR LOAD LIGHTS: Two rear load lights shall be provided on the rear of the module, above the rear access doors. The lights shall be Whelen LED-M9 series. The scene light group shall meet or exceed current Federal specification KKK-A-1822.

Bidder Complies YES_____ NO_____

BRIGHT CHROME-LIKE FLANGES: The M9 scene light group shall each have bright chrome trim flanges.

Bidder Complies YES_____ NO_____

REAR LOAD LIGHT SWITCHING: The rear load lights shall come on with a separate rocker switch located in the cab console controlled by a master switch. The switch shall be labeled "Rear Flood" and shall control both rear load lights on the rear of the body and above the rear access doors. The rear load lights will come on when rear doors are opened.

Bidder Complies YES_____ NO_____

A/C UNIT LOCATION: On the floor behind the attendant seat. A/C Unit will have a ducted delivery system in the ceiling with eight (8) adjustable vents. Two additional adjustable vents shall be located above and behind the attendant seat.

Bidder Complies YES_____ NO_____

WATER PUMP: There shall be an inline water pump to assist the water from the OEM chassis to the patient area heating system. This pump is to allow the vehicle to meet the KKK requirements for heating from a Cold Soak situation.

Bidder Complies YES_____ NO_____

REAR AIR CONDITIONING EVAPORATOR: The module shall have an additional, self contained A/C unit complete with an evaporator coil, heater core and a 12 volt blower. The fan shall be three speed and shall deliver 580 cubic feet of air per minute on high.

The unit shall be rated at least 32,000 British Thermal Units (BTU) in A/C Mode and 43,300 BTU in Heater Mode. The Vehicle A/C and Heat system must meet or exceed current Federal specification KKK-A-1822. The A/C and Heat unit will be located mounted horizontally over the ALS right front cabinet.

Bidder Complies YES_____ NO_____

CONDENSATION DRAIN PAN: A condensation pan shall be provided to collect water condensation from the evaporator coil. The drain pan shall be formed from 1/8 ABS plastic sheet and shall be listed (tilted) toward the drain fitting. The Evaporator unit shall be mounted so that the weight of the coil, case and blower assembly does not rest on the pan. Additionally, the entire evaporator shall list toward the condensation drain fitting to enhance water flow to the drain hose. The drain hose shall be ½ I. D., collapse resistant and fiber reinforced poly-tubing. The hose shall be routed from the condensation pan to the street.

Bidder Complies YES_____ NO_____

HEATER HOSES: Heater hoses for the cab shall remain OEM. 5/8 inside diameter, EPDM Nomex rubber hoses shall route from the OEM tie in point to the rear heater core.

Bidder Complies YES_____ NO_____

AIR CONDITIONING HOSES: All A/C Hoses shall meet Society of Automotive Engineers (SAE) J-2064. The discharge (High side) hoses shall not be less than 5/16 inside diameter (Size 6). The suction (Low side) hoses shall not be less than ½ inside diameter (Size 10). All hoses shall be A.S.T.M. Type D, with a thermoplastic inner liner (Nylon) that is protected by two textile reinforced braided electrometric outer jacket. The hose shall be qualified for use with R-134A, R-404 and R-407. The hose specified herein shall be subjected to a battery of tests per A.S.T.M. D-380. The results shall be supplied by the hose manufacturer. The flexible hoses shall connect to the metal end connections using the Burgaclip connection system and specialized tools, following the vendor's instructions.

Bidder Complies YES_____ NO_____

PRE-CARBON FILTER: The return air grille shall be supplied with a pre carbon filter that is designed to fit the slot within the grille. It shall be installed and shall not rattle. The filter shall be replaceable and/or cleanable by this department's fleet maintenance in the field.

Bidder Complies YES_____ NO_____

DUCTED AIR CONDITIONING DELIVERY: One duct shall route over the primary patient and attendant, and one shall run over the top area of the squad bench. Each duct shall contain four spherical and adjustable registers, evenly spaced. Two registers are located directly behind the attendant seat.

Bidder Complies YES_____ NO_____

REAR AC CONTROLS: An ON/OFF switch shall be located in the action area. The switch will not control fan speed. A separate three speed fan speed control switch shall be located in the action area control panel.

Bidder Complies YES_____ NO_____

LINER PANELS: The patient cabin head liner substrate material shall be one quarter inch thick, composite metal with powder coated finish laminated to center plastic material. An upholstered center panels shall provide access to ceiling wiring and be covered in the same upholstery type as the seat and back rest pads found on the squad bench and/or CPR seat.

Bidder Complies YES_____ NO_____

PATIENT CABIN DOME LIGHTS: The patient cabin shall have six dual intensity, Edge series LED dome lights in the ceiling. The dome lights feature new inner-edge LED placement to provide for full illumination with no hotspots while providing industry leading low-profile three-quarter inch recessed mounting depth. The lights are compatible with all previous industry eight inch in diameter lights with four mounting points. The lights centers shall be aligned along two, light banks. The left bank shall provide light directly over the patient: the right bank shall provide light directly over the aisle/squad bench. The lights shall feature an automatic function through the electrical system to automatically illuminate to a specified setting with the trailing rear or side entry door is opened and the conversion power is active. The dome lights and configuration shall meet current Federal Specifications KKK-A-1822.

Bidder Complies YES_____ NO_____

PATIENT CABIN FLUORESCENT LIGHTS: In addition to the base dome light package, three recess mounted fluorescent light shall be installed in the ceiling center pad, centered between the right and left bank of dome lights. The light(s) shall be 12 Volt Thinlite #716XL (18" long) or approved equal. A cutoff switch located in the action area panel will be installed in addition to the switch on the end of the fixture.

Bidder Complies YES_____ NO_____

FLUORESCENT LIGHT LOCATION: The aforementioned fluorescent light shall be located in the center panel of the patient cabin ceiling. The longitudinal light position shall emphasize light intensity on the patient.

Bidder Complies YES_____ NO_____

15 MINUTE TIMER: A variable 0 to 15 minute, spring wound, mechanical timer switch shall provide temporary illumination of the patient cabin for check out purposes. The switch input shall be wired directly to the vehicle batteries. The switch shall be located on the curbside wall, by the C/S access doors over the squad bench lid. The timer circuit shall comply with the latest revision of KKK-A-1822.

Bidder Complies YES_____ NO_____

LIGHTS POWERED BY TIMER: The aforementioned timer shall power all of the fluorescent lights, mounted in the ceiling panels. The duration of the light shall vary with the setting of the timer.

Bidder Complies YES_____ NO_____

IV HOOK No 1: One chrome plated, surface mounted IV hook, with a spring-loaded retention gate, shall be supplied in the ceiling of the patient cabin. The hook shall feature an anti-swing strap next to the hook.

Bidder Complies YES_____ NO_____

LOCATION: Located of the Primary patient, in the close proximity to the Head/Chest area of the patient.

Bidder Complies YES_____ NO_____

IV HOOK No 2: One chrome plated, surface mounted IV hook, with a spring-loaded retention gate, shall be supplied in the ceiling of the patient cabin. The hook shall feature an anti-swing strap next to the hook.

Bidder Complies YES_____ NO_____

LOCATION: Located of the Secondary patient, in the close proximity to the Head/Chest area of the patient.

Bidder Complies YES_____ NO_____

RECESSED CURB SIDE OVER HEAD ASSIST RAIL: The rail shall exceed the current revision of current Federal specification KKK-A-1822. The rail shall be 1 ¼ diameter, 100% stainless steel with gray anti-microbial coating and 72 inches long. All rail fittings shall be TIG welded to the main rail. The rail shall be recessed in an ABS pan 1.5", located curbside of center pad.

Bidder Complies YES_____ NO_____

MODULE INSULATION: The module insulation, except the under the floor shall consist of material having the following characteristics, 8mm thick nonabsorbent, reflective and shall have an air cell core. The air cell core shall consist of one layer of polyethylene bubble film that is sandwiched between one (1) layer of 99 percent pure aluminum foil and white colored polyethylene film. The insulation shall be installed with at least ½ air space from exterior skins, exposed to direct sun light. The insulation thermal rate testing shall be conducted in accordance with A.S.T.M. E84-89A, ANSI 2.5, NFPA 255, UBC 42-1, and U. L. 723. The insulation shall have a NFPA Class A and a UBC Class 1 fire rating with a flame spread index of 20 and a smoke developed index of 30. The application shall include a single layer of the insulation on all four walls, doors, compartments, and ceiling.

Bidder Complies YES_____ NO_____

SOUND BLOCK: There is to be Sound Block, sound deadening installed prior to the 1/2" subfloor. It shall be adhered directly to the vapor barrier and shall also include the interior of the body over the wheel well housings for a complete floor sound block. The material shall be less than 1/4" thick so as not to impede on the interior headroom. This sound deadening material has an additional insulation value of R-3 measured vertically. This DBMAX material in combination with other mounted substrates can produce a decibel reduction on average of 47 decibels for frequencies 250 - 5000 HZ.

Bidder Complies YES_____ NO_____

LED FLASHER: There shall be a Whelen universal LED for the sole purpose of flashing the additional LED front body lights in these specifications. The flash sequence shall be determined by the end user and put on the final build order sent to production.

Bidder Complies YES_____ NO_____

WARNING LIGHT: There shall be installed a Whelen M9 size Red LED light with Clear lens.

Bidder Complies YES_____ NO_____

LIGHT HEAD FLANGE: A Whelen bright chrome (Flange), on the above "M" Series light head(s) shall be installed.

Bidder Complies YES_____ NO_____

ALTERNATIVE LIGHTBAR SWITCHING: The switching of the lighting package that makes up the alternative light bar package shall be through the Primary/Secondary switching system. All red lights shall be through the primary side of the switch and any clear lighting (if optioned) shall be through the secondary side.

Bidder Complies YES_____ NO_____

PUBLIC ADDRESS (Visual) WARNING LIGHTS

WARNING LIGHT FLASHER: A Vanner Model 9860GCPE Heavy Duty, Duo-mode electronic flasher shall provide momentary power (Flash) the Halogen light heads at a rate of 75 to 80 flashes per minute (+-8%). The device shall have three output legs with maximum output current ratings of: Terminal A with sixty amperes, Terminal B with forty amperes and Terminal C with forty amperes. Primary mode is the standard running mode which flashes alternately between light heads powered off Leg A and those lights powered off Legs B and C. In secondary mode (used at the scene), all lights on Leg C will go out. The device shall function with an input voltage ranging from ten to sixteen volts, direct current (10V - 16V). The flasher shall operate in the most severe environments with an operating ambient air temperature range, around the device of negative forty to positive one hundred twenty-two degrees Fahrenheit. (-40 to 122 F) The input circuit shall be protected with overload protection. The flasher shall feature four flash patterns: Alternate Flash, Triple Burst Flash, Quad Burst Flash, and Dual Burst Flash. The flasher shall meet or exceed all GSA Triple K-1822 and AMD specifications.

Bidder Complies YES_____ NO_____

FLASH PATTERN: The warning lights shall flash in the sequence described in the present revision of the Federal specification KKK-A-1822.

Bidder Complies YES_____ NO_____

PRIMARY / SECONDARY SWITCH: The warning light system shall be controlled with a switch(es) located in the cab console. The switch(es) shall allow for "Off" position, "Primary" position, and "Secondary" position. Each output of the switch shall be indicated with a small red lamp, integrated in the switch legend area. The switch shall have an engraved, illuminated legend that clearly defines the function of the switch.

Bidder Complies YES_____ NO_____

GRILL WARNING LIGHTS: Warning lights shall be affixed to the chassis OEM grill as to not block air flow.

Bidder Complies YES_____ NO_____

FLANGES: The above lights shall have Whelen's optional bright trim bezel (Flange), to embellish the light head.

Bidder Complies YES_____ NO_____

WARNING LIGHT: There shall be a Whelen M2 warning light installed with Red Diodes. The light shall feature a built-in flasher that is programmable.

Bidder Complies YES_____ NO_____

WARNING LIGHT: There shall be installed Whelen M2 size Split RED/ White LED light with clear lens at the prescribed location. This light features a built-in programmable flasher.

Bidder Complies YES_____ NO_____

FLASH PATTERN: The programmable split color light shall have each independent color flasher programmed to a separate flash pattern by the up fitter. The flash pattern number shall be confirmed by the agency at the pre-construct meeting. The individual sections of the light are not synched to any other light portion.

Bidder Complies YES_____ NO_____

FLANGES: The above lights shall have Whelen's optional bright trim bezel (Flange), to embellish the light head.

Bidder Complies YES_____ NO_____

INTERSECTION LIGHTS:

LIGHT HEADS: A pair of Whelen Engineering, M4 Series LED Light heads shall be supplied in the aforementioned location. The light head shall feature Light Emitting Diodes. The light head shall comply with all photometric, chromaticity and physical requirements set forth in the current revision of Federal specification KKK. The lens shall feature a smooth outer surface designed to filter light frequency (Color) evenly over the area of the entire light head. A certificate of Compliance shall be made available to the agency upon request.

Bidder Complies YES_____ NO_____

LIGHT HEAD HOUSING: The intersection light shall have a contoured housing to fit the OEM fender.

WARNING LIGHT: There shall be a Whelen M2 warning light installed with Split colors Red and White Diodes. The light shall feature dual built-in flashers that are programmable.

Bidder Complies YES_____ NO_____

FLASH PATTERN: The programmable split color light shall have each independent color flasher programmed to a separate flash pattern by the up fitter. The flash pattern number shall be confirmed by the agency at the pre-construct meeting. The individual sections of the light are not synched to any other light portion.

Bidder Complies YES_____ NO_____

CENTER FRONT BODY LIGHT:

LIGHT HEADS: A Whelen Engineering, M9 Series LED Light head shall be supplied in the aforementioned location. The light head shall feature Light Emitting Diodes. The light head shall comply with all photometric, chromaticity and physical requirements set forth in the current revision of Federal specification KKK. The lens shall feature a smooth outer surface designed to filter light frequency (Color) evenly over the area of the entire light head. A certificate of Compliance shall be made available to the agency upon request.

Bidder Complies YES_____ NO_____

LIGHT HEAD FLANGE: A Whelen bright chrome (Flange), on the above "M" Series light head(s) shall be installed.

Bidder Complies YES_____ NO_____

WARNING LIGHT: There shall be installed a Whelen M9 size White LED light with Clear lens.

Bidder Complies YES_____ NO_____

OUTER FRONT BODY LIGHTS:

LIGHT HEAD: A pair of Whelen Engineering, M9 Series LED Light heads shall be supplied in the aforementioned location. The light head shall feature Light Emitting Diodes. The light head shall comply with all photometric, chromaticity and physical requirements set forth in the current

revision of Federal specification KKK. The lens shall feature a smooth outer surface designed to filter light frequency (Color) evenly over the area of the entire light head. A certificate of Compliance shall be made available to the agency upon request.

Bidder Complies YES_____ NO_____

LIGHT HEAD FLANGE: Whelen bright, chrome (Flange), on the above "M" Series light head(s).

Bidder Complies YES_____ NO_____

WARNING LIGHT: There shall be installed a Whelen M9 size Red LED light with Clear lens.

Bidder Complies YES_____ NO_____

UPPER SIDE BODY LIGHTS:

LIGHT HEADS: Two pair of Whelen Engineering, M9 Series LED Light heads shall be supplied in the aforementioned location. The light head shall feature Light Emitting Diodes. The light head shall comply with all photometric, chromaticity and physical requirements set forth in the current revision of Federal specification KKK. The lens shall feature a smooth outer surface designed to filter light frequency (Color) evenly over the area of the entire light head. A certificate of Compliance shall be made available to the agency upon request.

Bidder Complies YES_____ NO_____

LIGHT HEAD FLANGE: Whelen bright, chrome (Flange), on the above "M" Series light head(s).

Bidder Complies YES_____ NO_____

WARNING LIGHT: There shall be installed a Whelen M9 size Red LED light with Clear lens.

Bidder Complies YES_____ NO_____

REAR OUTER BODY LIGHTS:

LIGHT HEADS: A pair of Whelen Engineering, M9 Series LED Light heads shall be supplied in the aforementioned location. The light head shall feature Light Emitting Diodes. The light head shall comply with all photometric, chromaticity and physical requirements set forth in the current revision of Federal specification KKK. The lens shall feature a smooth outer surface designed to filter light frequency (Color) evenly over the area of the entire light head. A certificate of Compliance shall be made available to the agency upon request.

Bidder Complies YES_____ NO_____

LIGHT HEAD FLANGE: Whelen bright, chrome (Flange), on the above "M" Series light head(s).

Bidder Complies YES_____ NO_____

WARNING LIGHT: There shall be installed a Whelen M9 size Red LED light with Clear lens.

Bidder Complies YES_____ NO_____

CENTER REAR BODY LIGHTS:

LIGHT HEADS: A Whelen Engineering, M7 Series LED Light heads shall be supplied in the aforementioned location. The light head shall feature Light Emitting Diodes. The light head shall comply with all photometric, chromaticity and physical requirements set forth in the current revision of Federal specification KKK. The lens shall feature a smooth outer surface designed to filter light frequency (Color) evenly over the area of the entire light head. A certificate of Compliance shall be made available to the agency upon request.

Bidder Complies YES_____ NO_____

LIGHT HEAD FLANGE: Whelen bright, chrome (Flange), on the above "M" Series light head(s).

Bidder Complies YES_____ NO_____

WARNING LIGHT: There shall be installed a Whelen M7 size Amber LED light with clear lens.

Bidder Complies YES_____ NO_____

TWO BATTERY SYSTEM: The ambulance conversion and chassis shall run with two maintenance free twelve-volt batteries as specified below.

Bidder Complies YES_____ NO_____

BATTERY LOCATION: Both batteries shall be located under the OEM hood in the engine compartment.

Bidder Complies YES_____ NO_____

BATTERY BRAND: Both batteries shall be the OEM brand, same model and type. Each battery shall be rated at a minimum OEM rating. The batteries shall be warranted by the OEM manufacturer for at least three years (thirty-six months) from the date of delivery to the agency.

Bidder Complies YES_____ NO_____

BATTERY SWITCH: A conversion disconnect switch shall be supplied to remove positive polarity from the ambulance conversion circuits. Constant battery power shall be supplied for device memories. None of the chassis' functions shall be effected by this switch per Fords Qualified Vehicle Modifiers program, bulletin No 63. The switch shall be a Cole Hersee Model M2484-16 with a legend bezel that defines the ON and OFF position. An indicator light shall illuminate on the cab console panel.

Bidder Complies YES_____ NO_____

BATTERY JUMPSTART: There shall be a remote mounted Anderson style connector plug mounted on the exterior of ambulance chassis for hook up direct to batteries from an external source. The final location of this shall be determined by this agency for ease of operation. There shall be a set of cables built and shipped with the unit that consist of Anderson style connector on one end to match the end on the remote setup and jumper cable "Alligator" clamps on the other end. The cables shall be approximately 12' long.

Bidder Complies YES_____ NO_____

BATTERY JUMPSTART LOCATION: Front Bumper Area.

Bidder Complies YES_____ NO_____

POWER MODULE DOOR LOCKS: Each compartment and/or entry doors listed below shall Lock or Unlock with a single depression of a momentary switch. Each door shall be fitted with a bidirectional, momentary electric solenoid designed to operate a mechanical rod in a linear fashion. The rod shall mechanically interface with the door lock mechanism inside the door. All rod connections shall be designed for high cycle operation without mechanical disconnection. The battery compartment shall NOT have the power lock/unlock feature. This compartment shall remain key operated.

Bidder Complies YES_____ NO_____

DOOR LOCK SWITCH: The aforementioned door lock(s), shall be wired to activate with the OEM cab door locks and their switches in the cab.

Bidder Complies YES_____ NO_____

DOOR LOCK SWITCHES: Two momentary single pole, double throw rocker switches shall be supplied in a switch panel. One switch and panel shall be located near the side entry door and the rear access door. The panel shall include an engraved legend that describes the function of the switch. The legend shall illuminate with the battery switch.

Bidder Complies YES_____ NO_____

OEM KEY FOB OPTION: The aforementioned door lock(s), shall be wired to activate with the OEM cab door locks and their switches in the cab as well as the OEM remote key fob activator.

Bidder Complies YES_____ NO_____

DOOR LOCK SWITCHES: The module entry doors shall have internal integrated electric door lock activation switches.

Bidder Complies YES_____ NO_____

ONLY the following doors shall have power door locks:

POWER DOOR LOCK (M1): There shall be installed an electric solenoid powered actuator for the compartment door lock.

Bidder Complies YES_____ NO_____

POWER DOOR LOCK (M2): There shall be installed an electric solenoid powered actuator for the compartment door lock.

Bidder Complies YES_____ NO_____

POWER DOOR LOCK (M-3): There shall be installed an electric solenoid powered actuator for the compartment door lock.

Bidder Complies YES_____ NO_____

POWER DOOR LOCK (Rear Module Entry): There shall be installed an electric solenoid powered actuator for the module door lock.

Bidder Complies YES_____ NO_____

POWER DOOR LOCK (M-5): There shall be installed an electric solenoid powered actuator for the compartment door lock.

Bidder Complies YES_____ NO_____

POWER DOOR LOCK (M6): There shall be installed an electric solenoid powered actuator for the compartment door lock.

Bidder Complies YES_____ NO_____

POWER DOOR LOCK (Curbside Entry Door): There shall be installed an electric solenoid powered actuator for the module entry door lock.

Bidder Complies YES_____ NO_____

POWER DOOR LOCK (M7): There shall be installed an electric solenoid powered actuator for the compartment door lock.

Bidder Complies YES_____ NO_____

HIDDEN DOOR LOCK SWITCH: A weatherproof momentary switch shall be installed, concealed from view. Installation of Remote Door Lock Switch feature may increase likelihood of unauthorized entry into vehicle. By checking this option, purchaser further agrees to hold manufacturer or chassis manufacturer harmless for any loss of vehicle or contents caused by unlawful access.

Bidder Complies YES_____ NO_____

LOCATION: The switch shall be located in the OEM grille area.

Bidder Complies YES_____ NO_____
Ford OEM backup Camera installed, Cable, Displays into OEM Radio

Bidder Complies YES_____ NO_____
ELECTRICAL SYSTEM 12 Volt General

MODULE GROUNDING: A minimum of (2) two braided ground straps shall be through bolted to the chassis frame and the floor structure of the modular body. The bolts shall be at least 3/8 diameter. A flat washer shall be provided under the head of the bolt, over the strap lug. Additionally, an internal tooth lock washer shall preclude loosening. Conventional stranded copper cables are not acceptable because they do not suppress RFI and does not meet SAE J551.

Bidder Complies YES_____ NO_____
GENERAL GROUNDS: To comply with current Federal specification KKK-A-1822 plus enhance ground quality and reduce trouble shooting time, all devices wired within the ambulance conversion shall be centrally grounded. Each device shall have a separate ground wire routed to a central buss bar then grounded via fine strand cable to the module body. Local grounds are acceptable only when the device is drawing at or less than 100 milliamps (0.1 amps).

Bidder Complies YES_____ NO_____
12 VOLT WIRE: All wires within the ambulance harnesses shall meet current Federal specification KKK-A-1822. All wire insulation shall be GXL cross-linked polyethylene. Permanent wire identification and wire function shall be printed on 4 centers along the full length of the wire. Wire conductors shall be stranded copper.

Bidder Complies YES_____ NO_____
WIRE PROTECTION: All wire within the conversion shall be protected and run in split convoluted loom with a melting temperature of 300 degrees, Fahrenheit. All wire harnesses shall be clamped and routed to eliminate possibility of damage due to cut/chaffed wire. Grommets made of rubber or plastic shall be used where harnesses pass through metal or wood. Large holes and irregular shaped wire passages shall use automotive edge trim to protect the wire conduit/loom. Wire harnesses shall be neatly clamped into protective routing areas away from heat sources, unfriendly edges or moving devices.

Bidder Complies YES_____ NO_____
CIRCUIT BOARD: The single relay control board is a fully integrated relay control board designed and built to IPC Class 3* guidelines. The VF4 style socket relay is rated at 20A at 24 VDC with built-in on-board diode suppression. Three status indicators for Blown Fuse, Coil Power and Load allow for intuitive operation and troubleshooting. Also included is a medium sized ATO blade style fuse / circuit breaker holder that is rated for 20A. Wiring connections are made via a WAGO Cage Clamp removable lockable connector, which provides a secure, vibration proof and corrosion resistant wire termination. Installation time is reduced by as much as 75%. All of these features are mounted in a 2"x2" DIN Rail mountable package. Clearly, the Single Relay Control Board is a best-in-class solution for Emergency Vehicle relay applications.

Bidder Complies YES_____ NO_____
CIRCUIT BREAKERS: All conversion related circuits shall be protected with manual reset blade breakers. The value of the breaker for each circuit shall not exceed 75% of the rated capacity of the weakest component in the circuit.

Bidder Complies YES_____ NO_____
CAB CONSOLE: An ergonomically designed console with a A-A plywood substrate shall be contour matched to the cab floor. The console shall be a parallel wall design with a twelve- and one-half inch

over all width. End panels and center console bulkhead panels shall add rigidity and square to the console. The substrate shall be laminated per the following finish specification.

Bidder Complies YES_____ NO_____

SWITCH PANEL, CAB CONSOLE: A switch panel made from 3/16 thick, translucent, acrylic sheet. The acrylic material shall evenly disperse label, indicator illumination. The Sheet shall be coated with a black colored, rigid plastic film. A CNC router shall engrave, permanent switch legends, switch holes, meter holes, and indicator legends. The switches shall be organized in two rows. The top row shall start with an Emergency Master, followed by all of the emergency related switches. The bottom row shall start with a Master Switch, followed by all of the non-emergency related switches. The switch panel features an auto-dimming capability as related to a light sensor in the voltmeter. Each switch features a reinforced hub as part of the integral sealed housing. The Sealed rocker switches are LED illuminated. Each switch meets or exceeds IP66 ratings for contamination.

Bidder Complies YES_____ NO_____

REAR SWITCH PANEL, ACTION AREA: A switch panel made from 3/16 thick, translucent, acrylic sheet. The acrylic material shall evenly disperse label, indicator illumination. The Sheet shall be coated with a black colored, rigid plastic film. A CNC router shall engrave, permanent switch legends, switch holes, meter holes, and indicator legends. The sealed switches shall be organized in one row and control all patient compartment functions, dome lights, action area light, exhaust vent, inverter (if equipped), HVAC, suction pump and any added features.

Bidder Complies YES_____ NO_____

MASTER SWITCH: The patient area master switch shall be located in the cab switch console.

Bidder Complies YES_____ NO_____

VOLTMETER: The charging system voltage condition shall be indicated through a conventional two inch diameter, analog type gauge. The voltmeter shall be wired through the ignition switch and indicate system voltage ranging from eight to sixteen volts, direct current.

Bidder Complies YES_____ NO_____

COMPARTMENT AJAR INDICATOR LIGHT: A back lighted "Compt Open" light shall be engraved in the cab console's main switch panel. This light color shall be AMBER. The light shall meet current Federal Specification KKK-A-1822.

Bidder Complies YES_____ NO_____

INDICATOR LIGHT FUNCTION: The door ajar indicator light shall flash when two conditions are met:

- 1) The main conversion power switch is turned to the ON position.
- 2) Any compartment or entry door is opened.

The door ajar light shall come ON with a door that is not COMPLETELY latched.

Bidder Complies YES_____ NO_____

CONVERSION POWER "ON" INDICATOR LIGHT: An indicator light, labeled "Amb Pwr", referring to "Ambulance Power" shall be engraved in the cab console's main switch panel. The light color shall be GREEN. The light shall meet current Federal Specification KKK-A-1822.

Bidder Complies YES_____ NO_____

INDICATOR LIGHT FUNCTION: The "Amb Pwr" indicator light shall burn steady when the main conversion power switch is turned to the ON position.

Bidder Complies YES_____ NO_____

DOOR AJAR INDICATOR LIGHT: A back lighted "Door Ajar" light shall be engraved in the cab console's main switch panel. This light color shall be RED. The light shall meet current Federal Specification KKK-A-1822.

Bidder Complies YES_____ NO_____

SWITCHPANEL ILLUMINATION: Illumination of the switch panels shall be provided by LED strips attached to the underside of the switch panels. The strips shall be powered by 12volt DC.

Bidder Complies YES_____ NO_____

CAB CONSOLE FINISH: The console body shall be finished with a 20 mil Easy Grip film. The Easy Grip shall be a self-adhesive as well as bonded to the substrate with high bond contact adhesive. All joints shall be inconspicuous and bonded along the edges.

Bidder Complies YES_____ NO_____

AUXILIARY CAB CONSOLE: A ergonomically designed extension console shall be contour matched to the Main ambulance conversion console. The console shall be a tapered design with a fourteen- and one-half inch width at the front of the console and a twelve inch width at the rear of the console. The height shall not exceed the height of the engine cover console measured at the rear. The length of the console, measured at the center, shall be at least twenty-one inches.

Bidder Complies YES_____ NO_____

DRINK HOLDERS: The aforementioned extension console shall feature two drink holders, each with inside diameter of three inches. The drink holders shall be recessed into the console with one piece, self-rimming trim rings. The console finish and the drink hole recessed areas shall be waterproof, due to cup condensation.

Bidder Complies YES_____ NO_____

The Drink Holder shall be located at the Front of the Add On Console.

Bidder Complies YES_____ NO_____

NOTEBOOK SLOT: The aforementioned extension console shall feature a four inch by full width slot specifically designed to hold notebooks and/or clipboards. The inside finish of the slot shall be of the same material as the outside laminate. The slot shall be located in the rearward most end of the extension console.

Bidder Complies YES_____ NO_____

The aforementioned "notebook slot" shall feature two removable dividers that are evenly spaced in the slot. Extruded C-channels fastened to the sides shall be employed to secure the dividers into place.

Bidder Complies YES_____ NO_____

GLOVE STORAGE: There shall be glove storage at the rear of the add on console as part of the add on console. It shall be designed to hold (4) four boxes of gloves standing on end for easy access.

Bidder Complies YES_____ NO_____

CAB CONSOLE FINISH: The console body shall be finished with a 20 mil Easy Grip film. The Easy Grip shall be a self-adhesive as well as bonded to the substrate with high bond contact adhesive. All joints shall be inconspicuous and bonded along the edges.

Bidder Complies YES_____ NO_____

BACK UP ALARM: The apparatus shall include a 97 to 107 decibel back up alarm, activated by shifting into reverse.

Bidder Complies YES_____ NO_____

The apparatus back up alarm shall not include any type cut off device.

Bidder Complies YES_____ NO_____

GROUND STRAPS: Four (4) 7/8" wide by 1/8" thick, fine strand, woven straps shall provide a ground path from the module body to the chassis frame. Woven straps filter out RFI noise originating from alternators, strobe power supplies and other devices, that may find their way into intercom, stereo and two-way communication radios. Each end of the ground straps shall be through bolted with 3/8" diameter, grade 5 or 8, hex head bolts and lock nuts. Each connection site shall be cleaned to the bare metal prior to fastening the strap. The connections shall have a di-electric anti corrosion spray applied.

Bidder Complies YES_____ NO_____

12 VOLT POWER INVERTERS: A highly reliable inverter shall be supplied, installed and wired to the 125-volt outlets specified herein. The inverter shall produce 2,600 watts (7,800 watts surge) of RMS regulated, CONTINUOUS 125 Volt, AC power with a frequency ranging from 59.9 to 60.1 Hertz. The modified sine wave AC output shall be produced by a unique "power brick" that utilizes MOSFET power semiconductors.

The system logic functions shall be performed by a powerful microprocessor controller. The controller shall provide protection interlocks over the temperature, AC load and LOW BATTERY shutdowns. The output AC frequency is precisely controlled by a highly accurate crystal circuit.

The inverter enclosure shall be painted aluminum. All fasteners on the device shall be made non-corrosive material. All internal circuit board shall be comfortably coated to resist moisture in damp operating environments and vehicle vibration. A thermostatically controlled fan shall cool the unit.

The inverter control panel shall be located on the enclosure front. The inverter shall have an internal transfer switch, specifically designed to transfer the inverter load from "inverter" power to "shoreline" power when the shoreline is plugged in. The transfer switch shall make the transfer within 30 milliseconds.

BATTERY CHARGER: The aforementioned battery charger shall feature an internal 120-amp battery charger. This Built-in battery charger shall automatically charge either "Gel" or wet (Flooded) cell lead acid batteries in three stages: Bulk Charge Mode (constant current), Absorption Charge Mode (constant voltage), and Float Charge Mode (maintenance).

Bidder Complies YES_____ NO_____

POWER SOURCE FOR PORTABLE EQUIPMENT No 1: Positive and Negative polarity fourteen-gauge wires shall be supplied and installed for subsequent storage of portable equipment. The wires shall have 36" tails and be barreled off and protected by a ten (10) ampere automatic reset circuit breaker.

Bidder Complies YES_____ NO_____

LOCATIONS: The power sources shall be located with one in the chassis cab console and one behind the patient action area panel.

Bidder Complies YES_____ NO_____

POWER SOURCE: The aforementioned power provision shall be fed off of the output of the ignition switch or when the battery charger/conditioner is connected to the shoreline.

Bidder Complies YES_____ NO_____

125 VAC to 12 VDC CONVERTER/BATTERY CHARGER No 1: A IOTA Engineering, LLC, Model DLS-15 Converter with a 15 ampere output capacity shall be supplied and installed. The device shall convert a 125 Volt, 60 Hertz Alternating current input into 13.4 to 13.6 Volt Direct current. The device shall provide clean, constant D.C. Power. When specified below this device shall be capable of serving as a battery charger that charges up to its full output capacity and tapers back the output to a maintenance mode depending upon the need of the batteries

This DLS series battery charger/power supply shall be designed with high quality components that have life span ratings of up to ten years of continuous use. This device shall feature self protection features including:

1) AC Input Protection: This protects against damaging spikes (up to 190 Volts) AC that may come from the line or generator.

2) Reverse Battery Polarity Protection: This protects against incorrect wiring hook up through fuses that can be easily replaced.

3) Brown Out Input Protection: Protects against input spikes created by temporary or intermittent loss of input power.

4) Over Current Protection: Protects against supplying too much output current.

5) Over Temperature Protection: Protects against thermal damage with a unique proportional fan control circuit that turns on a whisper quiet when the unit reaches 35 degrees Fahrenheit (35 degrees Celsius).

Warranty: The device shall be covered by the manufacturer for a period of two years against defects in materials or workmanship from the date of retail delivery. An alternate charger / Converter may be supplied provided the alternate is equal in function, warranty and the alternate device has been approved by the agency prior to production.

Bidder Complies YES_____ NO_____

IV WARMER LOCATION: TBD

Bidder Complies YES_____ NO_____

CONVERTER TO POWER: The aforementioned converter/charger shall power the Portable Equipment Pre-wire within these specifications when the shoreline is connected, and the aforementioned converter/charger has 110vac power.

Bidder Complies YES_____ NO_____

BUILT-IN BATTERY CHARGER: The aforementioned built-in battery charger shall be wired to the vehicle batteries to allow charging/conditioning when the shoreline is energized.

Bidder Complies YES_____ NO_____

The power inverter shall reside in the left front middle compartment.

Bidder Complies YES_____ NO_____

COVER: There shall be a Lexan Cover over the inverter for protection.

Bidder Complies YES_____ NO_____

CRADLEPOINT: IBR900-600-NPS router shall be installed per customer specifications.

Bidder Complies YES_____ NO_____

RADIO POWER

POWER SOURCE FOR COMMUNICATION RADIO(S) No 1: Positive and Negative polarity ten gauge wires shall be supplied and installed for subsequent installation of communications radio(s). The wires shall be barreled off and protected by a thirty (30) ampere automatic reset circuit breaker.

Bidder Complies YES_____ NO_____

POWER SOURCE: The power provision shall be fed off of the output of the conversion main power (Battery) switch.

Bidder Complies YES_____ NO_____

LOCATION: The power source shall be located behind the passenger's seat, in the cab.

Bidder Complies YES_____ NO_____

POWER SOURCE FOR COMMUNICATION RADIO(S) No 2: Positive and Negative polarity ten-gauge wires shall be supplied and installed for subsequent installation of communications radio(s). The wires shall be barreled off and protected by a thirty (30) ampere automatic reset circuit breaker.

Bidder Complies YES_____ NO_____

POWER SOURCE: The power provision shall be fed off of the output of the conversion main power (Battery) switch.

Bidder Complies YES_____ NO_____

LOCATION: The power source shall be located behind the Action area control panel in the patient cabin.

Bidder Complies YES_____ NO_____

ANTENNA LEADS

COMMUNICATIONS RADIO ANTENNA PRE-COAX No 1: This coaxial cable shall be RG58-U type. There shall be an 18-inch service loop at the mod roof and a 36-inch tail at the interior termination point. A tag shall specify the other termination point for each coax provided.

Bidder Complies YES_____ NO_____

ORINATION POINT: The Coaxial cable shall originate on the module roof. The port location shall be centered side to side and approximately 36" back from the front edge of the module roof.

TERMINATION POINT: The Coaxial cable shall terminate in the cab / drivers' cabin behind the passenger seat.

Bidder Complies YES_____ NO_____

125V SHORE LINE AND OUTLETS

SHORE LINE INLET No 1: The primary 125 Volt shoreline inlet, rated at 20 Amperes shall be supplied. The plug style shall be a straight blade (NEMA 5-20P) style with a U-shaped ground. The inlet shall automatically eject the shoreline connector when the vehicle ignition switch is placed in the START position. The shoreline inlet shall employ a novel internal switch that closes and opens the 125 Volt circuit after the mating connector is inserted and before the connector is removed to eliminate arcing at the connector contacts. This will prolong the life of the inlet and the shoreline connector. The inlet shall be protected with a weatherproof cover.

Bidder Complies YES_____ NO_____

SHORE LINE COVER: The shoreline inlet shall be protected with a Yellow weatherproof cover.

Bidder Complies YES_____ NO_____

SHORELINE EJECT TIMER: The shoreline timer shall be an Inpower VCM-05-01SF to allow the auto eject to be wired to the ignition switch ILO splicing into the OEM starter circuit

Bidder Complies YES_____ NO_____
125 VAC OUTLETS

125 VAC OUTLET No. 1: The following outlets shall be UL listed, 125 Volt, Hospital grade, Straight blade NEMA 5-15R outlets. Each outlet shall be installed in a UL listed, recessed, fiberglass back box with a minimum of one- and three-quarter inch of box depth. The outlet cover shall be stainless steel. The outlet must be grounded and protected by a GFI (Ground Fault Interrupted) Breaker. Each outlet body must illuminate when power is applied to the outlet. Each outlet shall be clearly labeled with a permanent RED colored decal defining the outlet voltage.

Bidder Complies YES_____ NO_____
OUTLET LOCATION: This 125 Volt outlet shall be located in the patient cabin's, main "Action Area", with location as shown on the approval drawings.

Bidder Complies YES_____ NO_____
125 VAC OUTLET No. 2:

OUTLET LOCATION: This 125 Volt outlet shall be located inside of the right front ALS Cabinet. The outlet shall be mounted on the back wall of the cabinet (related to inside access) in the upper right corner. The location of the outlet shall be defined on the proposal drawings.

Bidder Complies YES_____ NO_____
125 VAC OUTLET No. 3:

OUTLET LOCATION: This 125 Volt outlet shall be located in the patient cabin's, telemetry area that is located just aft of the street side CPR side seat. The outlet shall be mounted on the back wall so that the depth of the back box does not protrude into adjacent cabinets. The location of the outlet shall be defined on the proposal drawings.

Bidder Complies YES_____ NO_____
125 VAC OUTLET No. 4:

OUTLET LOCATION: The outlet's location shall be defined at a pre-construction meeting and noted to the manufacturer.

Bidder Complies YES_____ NO_____
INTERIOR 12 Volt Direct Current (DC) OUTLETS:

12 VOLT OUTLET No 1: This outlet shall be a, 12 volt, direct current, 20 Ampere, automotive "cigar" lighter size commercial outlet. This outlet shall be located and wired as specified below. The outlet shall be separately protected and shall be electrically isolated from other electrical functions on the vehicle. This outlet shall be wired per current Federal specification KKK-A-1822.

Bidder Complies YES_____ NO_____
OUTLET LOCATION: This 12 Volt outlet shall be located in the patient cabin's, main "Action Area", on the back wall.

POWER SOURCE: The input for the outlet shall be wired to the output of the battery switch.

Bidder Complies YES_____ NO_____
ELECTRONIC SIREN: The Whelen 295HFSC9 siren hardware shall consist of a combination control head with integrated amplifier. The mono or dual sound output shall include 8-programmable operating profiles and include a removable microphone. The siren control head shall feature a

rocker type power switch, rotary function/Mode switch, a Manual momentary button switch and a microphone volume control potentiometer.

Bidder Complies YES_____ NO_____

SIREN SPEAKERS: Cast Products model No SA4327-1-AEV siren speakers shall be supplied and installed through the front bumper. Each speaker shall have a 100-watt driver and shall emit from the front OEM bumper. The horn shall feature a bumper contour matched bezel that provides a mounting rim large enough for four counter sink fastener holes. The ambulance manufacture shall use four (4) stainless steel, #2 Phillips oval head 1/4-20 x 2" machine screws with stainless steel nylon type locking nuts, stainless steel split lock washer and flat washers to fasten each speaker to the bumper. The siren and speakers shall meet or exceed all performance criteria set forth in Federal specification KKK-A-1822D 3.14.6. For any non-similar metal surfaces a corrosion inhibitor compound prior to final installation of the speakers.

Bidder Complies YES_____ NO_____

SIREN OR HORN SELECTOR SWITCH: The OEM horn ring shall control the OEM electric horn and the siren's manual momentary input controls. A switch shall connect the horn ring to either the OEM HORN or to the SIREN. The switch shall be located in the cab console's switch panel. The switch legend, that clearly defines the switch function shall be engraved in the switch panel. The legend shall be illuminated when the head light switch is on.

Bidder Complies YES_____ NO_____

GENERAL CABINET CONSTRUCTION

SUBSTRATES: The interior cabinets and components shall be constructed of exterior water boil proof resin (WBP). The glue line between layers shall be of similar chemical makeup as the phenolic resin used in marine Grade plywood, as designated by the APA (American Plywood Association). Phenolic resins are designed to eliminate formaldehyde off gassing often associated with most hardwood plywood. The exposed layers of the substrate shall be hard wood on both sides of the sheet, these layers shall be 99% void free. Cabinet cases are to be made from at least 12mm thick, minimum 5 ply. Bench Lids and Doors shall be made from at least 18 mm thick, minimum 7 ply.

CABINET INTERIOR FINISH: Cabinet interior shall be laminated with white colored, high impact, abrasion resistant laminate. The contact adhesive shall be a high bond contact adhesive, specifically designed to bond plywood to laminate. The laminate shall be at least 28 mills thick.

LAMINATE: A high impact, phenolic backed, high impact, and abrasion resistant laminate shall be used. The laminate shall be at least 45 mills thick. This material as well as all interior components shall meet or exceed FMVSS #302 (Burn rate of interior components). Color selection shall be specified at the pre-build conference.

CABINET ASSEMBLY: To maximize fastener bite, cabinet substrate parts shall be stapled with pneumatic fired equipment. The length of the fastener shall be at least 2.25 times the thickness of the material being pierced through. In addition to staples, the entire cabinet assembly must be screwed together with a minimum #8 screw size and a length not less than 2.25 times the thickness of the pierced substrate. Screw heads shall be countersink type and driven flush. Reinforcement cleats shall be bonded to the inside corners where the backside of the face of the cabinet meets the case of the cabinet. The glue used shall be, yellow colored waterproof resin type.

CABINET TRIM: All trim throughout the interior conversion shall be anodized aluminum or formed stainless steel. All exposed corners within the patient compartment shall have padded or rounded corners. Rounded corners shall be at least .250-inch radius. Rounded corners shall not compromise maximum cabinet assembly strength. The trim shall be bonded with a high strength adhesive.

FIT AND FINISH: Mitered joints throughout the interior conversion shall have a gap-less, hairline fit. Sliding polycarbonate door assemblies shall be scratch free and all edges shall be smooth and free of saw marks and sharp edges. Cabinet to cabinet joints shall not require more than 7/32 diameter welting to create a finished/well-fit look. Cabinets shall fit tightly against the ceiling as well.

FUNCTION: Doors and drawers shall fit the opening. When specified, flush fitting doors shall have even door to opening gaps. All doors shall open and close bind free. Drawers shall slide in and out freely, without drag. All drawers shall be mounted on side mounted, full extension drawer slides, rated no less than 75 pounds per pair. All hinged wood core doors shall have positive latches. High traffic, high cycle doors shall have adjustable tension, brass bodied catches. All hinged polycarbonate doors shall have adjustable tension, brass bodied catches.

CABINET DOORS

SLIDING POLYCARBONATE DOORS: Polycarbonate shall hereinafter be identified as Lexan. Unless specified otherwise, all cabinets along the street and curb side of the vehicle shall have a mitered framed, sliding transparent Lexan door assembly. The polycarbonate shall be at least 3/16 inch thick. Each door shall be fitted with a full length, extruded aluminum door handle. The door pull extrusion shall also add bend resistance to the door. The door track/Frame extrusion shall incorporate a flocked natural rubber track insert to prevent the doors from sliding free during transit. The corners of the assembly shall have drive-in corner spline. Each spline shall be riveted into place. All extrusions shall be anodized.

HINGED POLYCARBONATE DOORS: Polycarbonate shall hereinafter be identified as Lexan. The polycarbonate shall be at least 3/16 inch thick. The desired thickness shall be noted within this specification at each door location. The door orientation, hinge style and latch shall also be noted at each door location as well. The door edges shall be rounded and smooth since it will be the finished edge that will be visible.

SOLID HINGED DOOR: When a solid door is specified, a 3/4" (19mm) thick door shall be supplied on the cabinet. The substrate shall be 7-ply, A-A (Cabinet grade), hardwood plywood. The door shall be flush fitted to the opening and have uniform gap spacing around the perimeter of the door. The door shall be hung on a continuous, stainless steel piano hinge with mounting screws, spaced every two inches along the full length of the pre-punched hinge. The door shall be finished on both sides with white cabinet liner laminate on the inside and the same-colored mica as the cabinet fascia on the outside.

Bidder Complies YES_____ NO_____

MICA COLOR: The mica color selection shall be Light Gray with a Glossy finish. A sample of the subject mica color shall be supplied at the post award conference.

Bidder Complies YES_____ NO_____

LEXANTM COLOR: The LEXANTM throughout the vehicle shall be transparent with a gray medium tint. All doors shall be at least three sixteenths of one inch thick (3/16"), shatter proof and scratch resistant. The edges of the door shall be worked and burned smooth. The material shall be flexible enough to be cold formed (Bent) at ninety degrees, without fracturing the material.

Bidder Complies YES_____ NO_____

HANDLES, LEXAN WINDOW DOORS: Full height, anodized aluminum, extruded drive on handles shall be supplied on each 3/16" door. The handle shall wrap around the leading edge of each door and mount with one-way angular, blind mounting teeth designed to be driven on.

Bidder Complies YES_____ NO_____

ATTENDANT SEAT: There shall be a high back captain's seat mounted in the patient area with a Per4Max 4-point black seat restraint. The seat shall have enhanced foam bolsters at the tech sides and headrest portion, exclusive to the AEV brand. The seat shall have an integrated child safety seat with a pull down backrest and concealed 4-point child restraint. The seat shall be mounted per the requirements in the latest revision of KKK-A-1822. The seatbelt on the main part of the seat shall be an integrated, Per4max belt system that is supplied and tested by the seat manufacturer as a complete package. The seat color shall be Gunmetal.

Bidder Complies YES_____ NO_____

SEAT BASE: There shall be a powder coated metal seat that is tested to be utilized with the mounted EVS seat. The metal base shall be concealed behind a substrate with mica laminate to be color keyed to the patient area interior. There shall be a flush mounted solid door on a stainless-steel hinge with a spring loaded lever latch.

Bidder Complies YES_____ NO_____

SOLID HINGED DOOR: A 3/4" (19mm) thick door shall be supplied on the aforementioned cabinet. The door shall be flush fitted to the opening and have uniform gap spacing around the perimeter of the door. The door shall be hung on a continuous, stainless steel piano hinge with mounting screws, spaced every two inches along the full length of the pre-punched hinge. The door shall be finished with diamond plate.

Bidder Complies YES_____ NO_____

DOOR EDGE FINISH: The edges of the aforementioned door(s) shall be covered with anodized aluminum, U-shaped trim. The trim shall be miter cut and wrapped around the perimeter of the door (On ALL four sides), including the hinged side. The trim shall be bonded to the door edge and clamped. No screws or other mechanical fastener shall be used to fasten the trim work to the door(s). The corners of the doors shall be broken (rounded) after application. Vinyl "Iron on" or mica edge banding is not acceptable.

Bidder Complies YES_____ NO_____

HINGE ORIENTATION: The aforementioned door shall be hinged along the bottom edge of the door.

Bidder Complies YES_____ NO_____

NON-LOCKING LATCH: A black positive latch shall be supplied and installed on the cabinet door. A small "preload" on the latch shall be imposed to prevent the door from rattling.

Bidder Complies YES_____ NO_____

STOWAGE LABEL: A label shall be applied for any door, drawer, or other stowage area secured by a black lever latch, indicating its ability to restrain 8 pounds of contents within the stowage area. This latch has been tested and is compliant within the requirements of SAE J3058 as required under Federal specification KKK-A-1822F section 3.11.3.

Bidder Complies YES_____ NO_____

ARM RESTS: The aforementioned captains' chair attendant seat shall have an arm rest for both arms of the seated attendant. The arm rests shall swivel upward to facilitate easy egress.

Bidder Complies YES_____ NO_____

AIR CONDITIONING EVAPORATOR CABINET: The patient cabin shall be equipped with a rear air conditioning and heat unit. It will have a ducted heat and A/C delivery system. The system will have (10) spherical adjustable vents. There will be (8) vents will be located in ceiling panel, (2) vents on the heat/ac panel. A cabinet specifically designed to fit, form and function to the constrains set forth in the surrounding cabinet design and air exchange for cooling/heating performance

requirements, shall be installed in the upper right front corner of the patient cabin. The cabinet design shall include enhanced condensation water drainage by angling the entire evaporator unit toward the drain hose. The design shall provide adequate air return to meet or exceed current Federal specification KKK-A-1822. There will be an air return plenum extending full length in ALS cabinet for sufficient air return.

Bidder Complies YES_____ NO_____

BULKHEAD UPPER AND CIRCUIT BOARD CABINET: This cabinet shall be located behind and over the seated attendant. Access to the main circuit board shall be provided through the cabinet back. Screw on panels over the main circuit board is not acceptable. The door shall feature a detachable cable door check. When the cable check is attached to the door the door shall be supported at ninety to one-hundred degrees from the closed position. When the cable check is disconnected, the door shall be capable of opening up to one-hundred and eighty degrees. The cable shall be detachable by a spring loaded clip so that there are no parts that are lost when the cable is disconnected.

Bidder Complies YES_____ NO_____

SOLID HINGED DOOR: A solid door shall be supplied on the cabinet. The door shall be flush fitted to the opening and have uniform gap spacing around the perimeter of the door. The door shall be hung on a continuous, pre-punched stainless steel piano hinge with mounting screws. The door shall be finished sides with white cabinet liner on the inside and with the same colored mica as the cabinet face on the outside of the door. The door will have two vents.

Bidder Complies YES_____ NO_____

DOOR EDGE FINISH: The edges of the aforementioned door(s) shall be covered with anodized aluminum, U-shaped trim. The trim shall be miter cut and wrapped around the perimeter of the door (On ALL four sides), including the hinged side. The trim shall be bonded to the door edge and clamped. No screws or other mechanical fastener shall be used to fasten the trim work to the door(s). The corners of the doors shall be broken (rounded) after application. Vinyl "Iron on" or mica edge banding is not acceptable.

Bidder Complies YES_____ NO_____

HINGE ORIENTATION: The aforementioned door shall be hinged along the top edge of the door.

Bidder Complies YES_____ NO_____

NON-LOCKING LATCH: A black positive latch shall be supplied and installed on the cabinet door. A small "preload" on the latch shall be imposed to prevent the door from rattling.

Bidder Complies YES_____ NO_____

RIGHT FRONT CABINET (I): The right front cabinet is hereinafter known as ALS cabinet. All fixed and adjustable shelf surfaces shall be covered in Easy Grip material. All fixed and adjustable shelf lips shall be covered with anodized aluminum trim. All shelves shall have a ¾ lip. The ALS cabinet shall be configured as follows.

Bidder Complies YES_____ NO_____

ALS CABINET WEBBING: There shall be a removable cover over the right front ALS cabinet opening. The cover shall consist of 2" seat belt webbing material. The 2" webbing shall be constructed so that the openings are no larger than about 7" squares. The ends shall be sewn in loops to allow installation through a metal footman style loop that will be fastened to the edge of the ALS cabinet. The netting shall be quick released for access to the secured equipment through automotive style metal buckles. The design shall be so that the stored medical equipment is not able to come through the holes in the net and is secured when the net is in place.

Bidder Complies YES_____ NO_____

STOWAGE LABEL: A label shall be applied for the entire area covered by a single cargo net indicating its ability to restrain 80 pounds of contents within the stowage area. This net as built by the manufacturer has been tested to SAE J3058 and found to have a safe working capacity of 80 pounds of stowage capacity restraint. This item is compliant to section 3.11.3 of KKK-A-128F dated July 1, 2017.

Bidder Complies YES_____ NO_____

CABINET I-1: The upper section shall be approximately 25% of the overall height.

Bidder Complies YES_____ NO_____

OPEN CABINET - NO DOOR(S): The cabinet shall have full open access to all levels within the cabinet. The perimeter of the opening shall be protected with anodized aluminum trim. The trim shall be set with an adhesive in addition to counter sink screws.

Bidder Complies YES_____ NO_____

CABINET TRIM TYPE: The aforementioned cabinet opening shall be finish trimmed with three quarter inch by one quarter inch chamfered trim. The anodized trim shall be designed to be applied to an unrounded corner to maximize bonding area surface between the cabinet and the trim. The trim shall yield a chamfered outer corner and provide 3/4" material protection on one leg and 3/16" on the other leg. The frontal surface shall angle close (to within 1/32") of the cabinet fascia to minimize snagging clothing, equipment or other items while passing by the trimmed opening. The trim shall be thick enough to protect the access opening and withstand normal working abrasions of equipment coming out of and being placed into the cabinet.

Bidder Complies YES_____ NO_____

INTERIOR COLOR: The above cabinet interior surfaces shall be lined with Laminate that is color Keyed to the Vehicle interior laminate color.

Bidder Complies YES_____ NO_____

RIGHT REAR CABINET: The right rear exterior compartment specified herein shall be completely concealed from interior view by a right rear cabinet. All exposed surfaces of this cabinet shall be fully laminated over substrate matching main cabinet structures. The vertical outer corner shall feature a radius anodized aluminum trim. The trim shall originate from the top of the mated squad bench and terminate into the ceiling.

UPHOLSTERY PAD: An upholstered pad covering the entire forward-facing wall, over the squad bench shall be provided. The pad shall include at least 1/2" thick foam padding covered in the same heavy-duty vinyl covering specified for the squad bench cushions and the remaining upholstery package.

Bidder Complies YES_____ NO_____

SQUAD BENCH: A squad bench shall be installed on the curbside of the patient compartment. The number of seating locations shall be installed as described in the options following this general heading specification. All seat belts and anchorage shall comply with FMVSS. 209 and 210. The Squad Bench shall comply with current KKK-A-1822. A back and head rest shall be supplied for all seated personnel along the squad bench.

Bidder Complies YES_____ NO_____

BIO-WASTE RECEPTACLE No 2: A second biological waste receptacle shall be supplied and installed in the squad bench. The receptacle shall accommodate a sharps container and a solid waste container per the following paragraphs. Both the sharps and the solid waste containers shall be enclosed and secured in a molded enclosure, free of crevices. The molded enclosure shall be

covered with a red Lexan hinged door, inset a molded in perimeter rim. The door pull shall be a full length, ergonomically designed extruded aluminum pull, free of sharp edges. A white colored "Bio-waste" symbol and legend shall be applied to the aforementioned door.

Bidder Complies YES_____ NO_____

SHARPS CONTAINER: A puncture proof, disposable sharps container located at the head of the squad bench with a 3-quart capacity shall be supplied for safe disposal of used/contaminated syringes. The unit shall include a spring-loaded clip in the mounting to allow for secure mounting in the case of an accident.

Bidder Complies YES_____ NO_____

WASTE CONTAINER: One six quart (346 cubic inch), rimmed plastic waste container shall be supplied and fitted into the "Bio-waste" enclosure.

Bidder Complies YES_____ NO_____

UNDER LID STOWAGE: The squad bench shall provide storage under the access lids. This multipurpose storage area shall be finished in high impact, white colored laminate. Must meet current Federal specification current KKK-A-1822.

Bidder Complies YES_____ NO_____

SQUAD BENCH LIDS: Two (Split) squad bench lids shall be supplied over the squad bench storage area.

Bidder Complies YES_____ NO_____

HINGE, SQUAD BENCH LID(S): All squad bench lids shall be installed with butt style, hinges. The hinges shall be through bolted for longevity of the vehicle. There shall be a minimum of two hinges per lid.

Bidder Complies YES_____ NO_____

LID CHECKS: Each squad bench lid shall have a bi-directional gas spring lid check (Hold open). The force value selected and ball stud locations shall provide lift assistance after twenty degrees of bench lid lift angle. The ball stud mounts shall be at least 10 millimeter.

Bidder Complies YES_____ NO_____

LID LATCH: One latch to hold each lid down shall be supplied. The lid latch shall be stamped stainless steel construction and latches automatically by simply closing the bench lid. There shall be a slot milled into the underside of the bench lid to accept an manufactured keeper that will prevent the lid from pulling away from the latch. The paddle latch will be through bolted to the keeper with the retaining nuts on the backside of the keeper as a complete assembly. This assembly has been tested to SAE J3058 standards and passed with the ability to contain 80 pounds in the entire area of the squad bench. A label shall be affixed to the squad bench area.

Bidder Complies YES_____ NO_____

STOWAGE LABEL: A label shall be applied near the squad bench exterior indicating the lids to the squad bench are restrained with a compliant latch. The latch assembly of the squad bench were tested to SAE J3058 standards to 80 pounds and found passing. The operator should not exceed the 80 pound weight rating for the entire squad bench storage area. This item is compliant to section 3.11.3 of KKK-A-128F dated July 1, 2017.

Bidder Complies YES_____ NO_____

EDGE TRIM: The edge of the squad bench lid shall be finished with aluminum anodized "J" trim. The trim is to be supplied with countersunk holes to allow for screws to be installed flush so the screw head does not catch anything.

Bidder Complies YES_____ NO_____

RESTRAINT NET: A detachable net shall be installed at the head of the squad bench. In the event of sudden stop or frontal accident, the design intent of the net is to minimize injuries to unbelted personnel seated on the squad bench. The net is a safety barrier between the occupant/personnel and the bulkhead cabinetry. The net shall be a grid of 2 wide safety web, spaced on maximum centers of 8 inches.

The net shall be secured at six points. The net shall be tightly stretched and attached at two points on each of the following surfaces:

The floor at head of squad bench

The curb side wall

The ceiling.

All Restraint Net attachment devices shall be aviation quality and pull strength tested. A 2,000 pound force applied in shear (Horizontally). Detachment of the net shall be done without the need for a removal or installation tool(s). Each device shall feature a cadmium plated steel attachment ring that is forged in one continuous ring, without a split or seam. Each device shall be sewn onto the net webbing with a 1 3/4 inch square shaped thread path and diagonal X-shaped thread path to assure web to ring security.

Bidder Complies YES_____ NO_____

CABINET "A": An upper, interior cabinet shall be provided directly over the rearward section of the Base wall cabinet. This cabinet shall accommodate a power air exhaust blower with a removable service panel. This multipurpose cabinet interior shall be finished in high impact, white colored laminate. Must meet current Federal specification KKK-A-1822.

Bidder Complies YES_____ NO_____

SINGLE FLIP UP POLYCARBONATE DOOR: A Single 3/8" (0.375 in) thick, overlay flip up door shall be supplied on the cabinet.

Bidder Complies YES_____ NO_____

HINGES: The hinges to hold up the access door shall be powder coated zinc Reel Torque style with a 30-pound torque setting each. Each hinge has a built-in friction action to provide a holding force of present amount to cause the hinge to resist movement in either direction. This hinge is intended to act as a hold open for a cabinet light door while the vehicle is not in motion.

Bidder Complies YES_____ NO_____

NON-LOCKING LATCH: A black positive latch shall be supplied and installed on the cabinet door. A small "preload" on the latch shall be imposed to prevent the door from rattling.

Bidder Complies YES_____ NO_____

STOWAGE LABEL: A label shall be applied for any door, drawer, or other stowage area secured by a black lever latch, indicating its ability to restrain 8 pounds of contents within the stowage area. This latch has been tested and is compliant within the requirements of SAE J3058 as required under Federal specification KKK-A-1822F section 3.11.3.

Bidder Complies YES_____ NO_____

CABINET "B": An upper, interior cabinet shall be provided directly over the "Action Area". This multipurpose cabinet interior shall be finished in high impact, white colored laminate. The cabinet shall be ergonomically angled toward the CPR seat. Must meet current Federal specification KKK-A-1822.

Bidder Complies YES_____ NO_____

SLIDING SECURE LATCH RESTOCKING WINDOW: There shall be a restocking sliding SECURE LATCH window installed at the location indicated. This window features several advanced safety features allowing it to meet the new SAE J3058 safety standard. This slider window features a full-length spring-loaded low-profile bar latch at both ends of the slider window that lock into an aluminum extrusion when the window is closed. The center of the window has aluminum inter-locking stiffeners of panel to distribute outward impact loads across both panels. The window shall be able to be opened with one motion and with one hand. To close the user can push the window and slam latch to closing. This window also features a lower release bar that allows the window to be opened to a restocking position for a majority clear access to the contents of the cabinets without accessing through the sliding window. The restocking feature is to be used when the vehicle is not in motion. This window has been tested to SAEJ3058 testing methods in a third-party testing facility and found to safely restrain 30 (thirty) pounds of contents. Windows that do not meet the SAEJ3058 safety requirements are not acceptable to this agency.

Bidder Complies YES_____ NO_____

Single Cabinet Multi-Pocket Aluminum Fixed divider and shelf system -

STOWAGE LABEL: A label shall be applied for any Secure Latch Restocking Sliding Window system indicating its ability to restrain 30 pounds of contents within the stowage area. This secure latch sliding window system has been tested and is compliant within the requirements of SAE J3058 as required under Federal specification KKK-A-1822F section 3.11.3.

Bidder Complies YES_____ NO_____

BASE WALL CABINET: The base wall cabinet is located on the Street side (Left side) of the patient cabin. The overall height of the Base Wall Cabinet shall be approximately 75% of the overall head room. This cabinet shall be built in ONE piece. The laminate along the fascia shall be ONE piece on single color laminate selections. A CPR Side Seat shall be provided on the street side aligned with the primary patient abdomen.

Bidder Complies YES_____ NO_____

ACTION AREA: The action area is a work surface located on the forward end of the Base Wall Cabinet and adjacent to the attendant seat. The work surface shall be at least 5.5 square feet. The work area height shall be 24 inches to 29 inches. The work surface shall have a three-quarter inch (3/4") high lip.

Bidder Complies YES_____ NO_____

A/A TRAY: There shall be a countertop action area forward at the wall cabinet. The countertop shall be color keyed high-pressure laminate to match the remainder of the high-pressure laminate in the patient area.

Bidder Complies YES_____ NO_____

SHARPS AND TRASH: There shall be a bio waste receptacle at the rear of the action area. It shall consist of an ABS tray within the mica countertop. The ABS tray shall allow for biological waste with separate needle disposal. The sharps and waste shall be molded into an ABS plastic tray. Access the bio-waste container and needle collection jar shall be done from the top of the action area in the patient compartment. The sharps container shall be a 3-Quart Bemis container with a spring located clip to hold it in place in the event of an accident.

Bidder Complies YES_____ NO_____

ACTION AREA BOARD: There shall be a single board containing the basic electrical and oxygen control systems of the patient area. This board shall be covered in black secure grip material. Proper spacing shall be maintained between electrical and oxygen connections. The board shall be

hinged by dual action concealed hinges and secured by quarter turn captive head bolts. The use of hinges and bolts allows for inspection of the connections during routine maintenance procedures.

Bidder Complies YES_____ NO_____

CABINET "C": An interior cabinet shall be provided at the rearward end of the base cabinet on the street side. This multipurpose cabinet interior shall be finished in high impact, white colored laminate. Must meet current Federal specification KKK-A-1822.

Bidder Complies YES_____ NO_____

SLIDING SECURE LATCH RESTOCKING WINDOW: There shall be a restocking sliding SECURE LATCH window installed at the location indicated. This window features several advanced safety features allowing it to meet the new SAE J3058 safety standard. This slider window features a full-length spring loaded low-profile bar latch at both ends of the slider window that lock into an aluminum extrusion when the window is closed. The center of the window has aluminum inter-locking stiffeners of panel to distribute outward impact loads across both panels. The window shall be able to be opened with one motion and with one hand. To close the user can push the window and slam -latch to closing. This window also features a upper release bar that allows the window to be opened to a restocking position for a majority clear access to the contents of the cabinets without accessing through the sliding window. The restocking feature is to be used when the vehicle is not in motion. This window has been tested to SAEJ3058 testing methods in a third-party testing facility and found to safely restrain 30 (thirty) pounds of contents. Windows that do not meet the SAEJ3058 safety requirements are not acceptable to this agency.

Bidder Complies YES_____ NO_____

STOWAGE LABEL: A label shall be applied for any Secure Latch Restocking Sliding Window system indicating its ability to restrain 30 pounds of contents within the stowage area. This secure latch sliding window system has been tested and is compliant within the requirements of SAE J3058 as required under Federal specification KKK-A-1822F section 3.11.3.

Bidder Complies YES_____ NO_____

COMPARTMENT INTERIOR ACCESS: The compartment shall not be accessible through the INSIDE of the module.

Bidder Complies YES_____ NO_____

SHELF STANDARDS: The aforementioned cabinet shall be equipped with non-incremental, aluminum, C-shaped shelf standards.

Bidder Complies YES_____ NO_____

ADJUSTABLE SHELF: A shelf shall be supplied in the cabinet. The shelf shall be finished in white colored laminate. Upper, lower and aisle side surfaces of the shelf shall be laminated. The shelf shall be secured to four shelf clips with Phillips's head wood screws, from the bottom of the shelf. An anodized aluminum angle shall be securely fastened to the front edge of the shelf. The vertical leg of the angle shall provide a lip along the front edge.

Bidder Complies YES_____ NO_____

CABINET "D": An interior cabinet shall be provided directly over the rearward "Telemetry Area just aft of the CPR side seat within the base cabinet on the street side. This multipurpose cabinet interior shall be finished in high impact, white colored laminate. The cabinet shall be ergonomically angled toward the CPR seat. Must meet current Federal specification KKK-A-1822.

Bidder Complies YES_____ NO_____

SLIDING SECURE LATCH RESTOCKING WINDOW: There shall be a restocking sliding SECURE LATCH window installed at the location indicated. This window features several advanced safety features

allowing it to meet the new SAE J3058 safety standard. This slider window features a full-length spring-loaded low-profile bar latch at both ends of the slider window that lock into an aluminum extrusion when the window is closed. The center of the window has aluminum inter-locking stiffeners of panel to distribute outward impact loads across both panels. The window shall be able to be opened with one motion and with one hand. To close the user can push the window and slam -latch to closing. This window also features a lower release bar that allows the window to be opened to a restocking position for a majority clear access to the contents of the cabinets without accessing through the sliding window. The restocking feature is to be used when the vehicle is not in motion. This window has been tested to SAEJ3058 testing methods in a third-party testing facility and found to safely restrain 30 (thirty) pounds of contents. Windows that do not meet the SAEJ3058 safety requirements are not acceptable to this agency.

Bidder Complies YES_____ NO_____

STOWAGE LABEL: A label shall be applied for any Secure Latch Restocking Sliding Window system indicating its ability to restrain 30 pounds of contents within the stowage area. This secure latch sliding window system has been tested and is compliant within the requirements of SAE J3058 as required under Federal specification KKK-A-1822F section 3.11.3.

Bidder Complies YES_____ NO_____

ADJUSTABLE SHELF: A shelf shall be supplied in the cabinet. The shelf shall be finished in white colored laminate. Upper, lower and aisle side surfaces of the shelf shall be laminated. The shelf shall be secured to four shelf clips with Phillips's head wood screws, from the bottom of the shelf. An anodized aluminum angle shall be securely fastened to the front edge of the shelf. The vertical leg of the angle shall provide a lip along the front edge.

Bidder Complies YES_____ NO_____

CABINET "F": An interior cabinet shall be provided directly below the rearward "Telemetry" Area just aft of the CPR side seat within the base cabinet on the street side. This multipurpose cabinet interior shall be finished in high impact, white colored laminate. Must meet current Federal specification KKK-A-1822.

Bidder Complies YES_____ NO_____

SOLID HINGED DOOR: A 3/4" (19mm) thick door shall be supplied on the aforementioned cabinet. The door shall be flush fitted to the opening and have uniform gap spacing around the perimeter of the door. The door shall be hung on a continuous, stainless steel piano hinge with mounting screws, spaced every two inches along the full length of the pre-punched hinge. The door shall be finished with white cabinet liner laminate on the inside and the same colored mica as the cabinet face on the outside.

Bidder Complies YES_____ NO_____

DOOR EDGE FINISH: The edges of the aforementioned door(s) shall be covered with anodized aluminum, U-shaped trim. The trim shall be miter cut and wrapped around the perimeter of the door (On ALL four sides), including the hinged side. The trim shall be bonded to the door edge and clamped. No screws or other mechanical fastener shall be used to fasten the trim work to the door(s). The corners of the doors shall be broken (rounded) after application. Vinyl "Iron on" or mica edge banding is not acceptable.

Bidder Complies YES_____ NO_____

HINGE ORIENTATION: The aforementioned door shall be hinged along the bottom edge of the door.

Bidder Complies YES_____ NO_____

NON-LOCKING LATCH: A black positive latch shall be supplied and installed on the cabinet door. A small "preload" on the latch shall be imposed to prevent the door from rattling.

Bidder Complies YES_____ NO_____

STOWAGE LABEL: A label shall be applied for any door, drawer, or other stowage area secured by a black lever latch, indicating its ability to restrain 8 pounds of contents within the stowage area. This latch has been tested and is compliant within the requirements of SAE J3058 as required under Federal specification KKK-A-1822F section 3.11.3.

Bidder Complies YES_____ NO_____

CPR SEAT: A left side "CPR" side seat shall be provided on the street side and aligned with the primary patient's abdomen. The seat shall be at least twenty-four (24") inches wide and normal squad bench seat height. Upholstered seat pads shall be located within the seat area for the seat, back, both arms and hips. The CPR seat area shall have rounded corners.

Bidder Complies YES_____ NO_____

BACK REST: The CPR side seat shall feature a padded, fixed back rest with chamfered upper corners.

Bidder Complies YES_____ NO_____

TELEMETRY AREA: A four-inch-wide upholstery covered and padded arm rest shall be installed. The arm rest shall create a 3/4" to 1" lip on the leading edge of the telemetry area.

Bidder Complies YES_____ NO_____

TELEMETRY AREA SURFACE TYPE: The "Telemetry area" shall be finished with the primary color laminate.

Bidder Complies YES_____ NO_____

RESTRAINT SYSTEM(S): There shall be installed a REV Per4Max restraint system harness at each seating location declared. This seating harness system shall incorporate a four point harness of two shoulder belts with retractors and two stationary lap belts that intersect to a single high function ergonomic latch. The harness shoulder belts shall incorporate innovative technology through patent pending controlled deceleration technology which softens the impact of a crash on the EMSP user. The seat belt harness also incorporates an indicator that alerts the operator when it requires replacement. The color of the seat belt system shall be black. This seat belt system shall meet current FMVSS safety standards.

Bidder Complies YES_____ NO_____

The REV Per4MaxOY Seat Belt System(s) shall be in the following locations:

RESTRAINT SYSTEM(S): The rear seating locations shall consist of the Per4Max 4-Point restraint system. The Per4Max Advanced Restraint System is a "Vehicle mounted" 4-Point restraint system dispersing loads to 4 points of reinforced structure within the vehicle as opposed to concentrating loads on the seat frame. It promotes a seated position with a wide range of mobility. The seated position in conjunction with the seat system, has been proven to be safer than isolated standing positions in a moving vehicle. As well it is easy to use encouraging greater use in the field than more cumbersome systems involving additional latches, levers, and cables. The seatbelt harness shall incorporate an indicator of contrasting color when the seatbelt has been involved in a high impact condition to indicate need for replacement. These seatbelts are FMVSS applicable tested and approved to AEV configurations.

There shall be two Per4Max restraints on the Squad Bench and one Per4Max restraints on the CPR Side Seat.

Bidder Complies YES_____ NO_____

SECONDARY PATIENT RESTRAINT SYSTEM: There shall be a location for a secondary patient on top of the squad bench located on the curbside interior of the patient area of the ambulance. To secure the patient there shall be three inertia style retractable straps that match up to three 9" sleeved

buckles on the face of the squad bench and 5" sleeved retractors by the squad bench lid hinge. The straps and buckles shall be mounted to comply with the pull test requirements in the present revision of KKK-A-1822.

Bidder Complies YES_____ NO_____

FLOOR AND SUBSTRATE: The underlayment shall be Thermo-Lite Board Tough, made with a medium weight woven fiberglass lay-up, this product is acceptable for standard structural load applications. The material density shall be 40 lbs per cubic feet for the 3/4" thickness material used for underlayment application. The material is a unique closed cell, lightweight composite product, manufactured with cross-linked polymer foam and fiberglass, that offers high specific strength and toughness. The non-absorbent material is extremely durable, provides an excellent bonding surface, has good impact strength, sound and thermal insulation, and is resistant to contamination.

Bidder Complies YES_____ NO_____

FLOOR COVERING: The flooring material shall be commercial grade sheet floor. No substrate seams are allowed in high foot traffic areas. This means NO SEAMS are permitted within 132" of the rear access doors or near the side access door. The core of the flooring shall be the same color as the surface. The flooring material shall be commercial grade sheet floor with diamond plate like impression on the surface. The floor covering shall be Lonseal Lonplate II No 424TX "Gun Metal" (Dark Gray). The main field of the flooring around the diamonds, shall be textured to minimize the appearance of minor scratches and imperfections brought on by wear.

Bidder Complies YES_____ NO_____

FLOORING MAIN EDGE: The one-piece patient cabin floor covering material shall run the full width of the aisle space plus roll up (3") three inches along the Base wall cabinet, squad bench and the right rear cabinet (when applicable). Both roll-up areas shall be recessed approximately 1/2" into the face of the cabinets.

Bidder Complies YES_____ NO_____

REAR THRESHOLD: The rear threshold shall be made of 16 gauge brushed stainless steel sheet. The threshold shall conceal the end of the vapor sheet, sub floor, and flooring. The threshold shall mate to the top of the rear access door jamb and cover at least six inches of flooring. Installed over the stainless steel threshold shall be two 2.5" wide "nonskid" tape, strips applied. The color of the tape shall be safety yellow with black diagonal stripes.

Bidder Complies YES_____ NO_____

C/S THRESHOLD: The C/S threshold shall be made of .100 polished aluminum diamond plate.

Bidder Complies YES_____ NO_____

COT MOUNT HARDWARE

COT PLATES: Full length cot plates made of 16-gauge stainless steel, with a brushed finish shall be supplied and laid out to fit the aforementioned cot. Each full-length cot plate shall originate at the full width threshold, run continuous and terminate just forward of the installed antler bar. The plate edges shall be rounded and positioned such that ALL cot wheels rest on the plates. The plates shall be affixed with high-grade double-sided adhesive, and the outer edges of the plates caulked with silicone. The intent here is to eliminate wheel dents in the vinyl floor covering.

Bidder Complies YES_____ NO_____

PRIMARY COT MOUNT: Prep for main cot mount, install support plate in floor, Cot mount shall be Customer/Dealer Supplied Stryker model No 6390 Power Load System.

COT FASTENER MOUNTING METHOD: All mounting bolts shall be 3/8" diameter, socket head cap screws with at least 16 threads per inch. All mounting blocks shall be supplied and manufactured by the cot mount manufacturer. The mounting blocks may protrude above the flooring surface by up to 3/16", as long as all of the edges are chamfered. The aforementioned cap screws shall not protrude above the upper surface of the mounting block.

Bidders shall meet or exceed mechanical strength described in the aforementioned minimum fastening method. Material thickness and/or through bolt criteria is mandatory even if the vendor has current certification to A.M.D. Standard 004 utilizing lesser materials.

Bidder Complies YES_____ NO_____

12v power feed location FRONT for Stryker power load 6390

COT POSITION No 1: This cot position shall be set up for a primary wheeled cot set centered laterally (side to side) in the aisle. The longitudinal location shall be set 30 inches measured from the backrest of the attendant's seat (set all the way toward the front of the patient cabin) to the head of the primary cot frame, per current KKK-A-1822.

Bidder Complies YES_____ NO_____

PRIMARY COT POSITION REINFORCEMENT: There shall be a singular piece of aluminum reinforcement installed running the length of the primary cot position in the modular ambulance. It shall be secured to the modular tubes by welding or Huck fasteners.

Bidder Complies YES_____ NO_____

PRIMARY COT: The aforementioned cot fastener shall be set up to use a Stryker Model No. Power-Pro Cot.

Bidder Complies YES_____ NO_____

COT HOOK: A Stryker Cot hook for the power load system of solid aluminum shall be through bolted to the power load system near the rear access doors. The design intent is to prevent accidental cot roll off during loading and unloading a one man cot. The hook shall snag a tubular drag bar that is built in to the cot frame. The cot hook shall be placed in a position where the under carriage of the cot can be erected and locked into place before release of the drag bar.

Bidder Complies YES_____ NO_____

OXYGEN, AIR and VACUUM SYSTEMS

OXYGEN HOSES: All oxygen system service hoses, fittings and devices shall be made of nonferrous materials. Hoses used to pipe Medical Oxygen shall be electrically non-conductive, ¼ inside diameter with an abrasion resistant, green colored outer jacket. The hose manufacturers name, part number, inside dimension and working pressure rating shall be permanently marked along the entire length of the hose. All hoses shall have a working pressure rating of at least 250 pounds per square inch, withstand a system test pressure of 150 PSI / 1033 kPa test prescribed in current Federal specification KKK-A-1822. Each ambulance shall be tested.

Bidder Complies YES_____ NO_____

OXYGEN OUTLETS - GENERAL: Each outlet shall be comprised of an "Inlet Box" and a "Latch Plate" as defined herein. The "inlet box" shall be a universal inlet service box with a 165 mm type "K" (3/8") OD Copper inlet pipe stub which is silver brazed to a brass, one piece, (1 5/16") inlet body. The "inlet box" shall be designed specifically for positive pressure gas service and feature a primary and secondary check valve. Each check valve shall be rated at 1,379 kPa (200psi).

The "Latch Plate" shall insert into the universal "Inlet Box". The "Latch Plate" is comprised of the outer cover plate and latching mechanism that will define the adapter type/Brand that will ultimately connect the patient to the oxygen system. The outlet cover shall be color coded GREEN in addition to having a clear permanent legend that identifies the gas type. Dual gas specific safety pins shall be integrated in the face of the outlet "Latch Plate" for safety.

Outlet adapter types shall be easily changed by simply removing the "Latch plate" specifically designed for brand "A" to brand "B" without any further plumbing changes.

As with all medical gas outlets specified herein, all outlets shall be hydrostatically tested and cleaned for oxygen service. All medical gas outlets specified herein shall be UL (Underwriters Laboratory) listed and CSA approved. All outlets will be subject to a line pressure of 50 PSI And shall be leak tested at 150 PSI Per Federal specification KKK-A-1822. Pressure drop across the outlet shall be less than 2.0 PSI At normal working pressure.

Bidder Complies YES_____ NO_____

OXYGEN OUTLET No 1: This outlet latch shall be designed to accept (Ohio) style, quarter turn / quick release adapters. This Oxygen outlet shall be provided where specified below.

Bidder Complies YES_____ NO_____

LOCATION: The Oxygen outlet shall be located in the primary action area switch and outlet console.

Bidder Complies YES_____ NO_____

OXYGEN OUTLET No 2: This outlet latch shall be designed to accept (Ohio) style, quarter turn / quick release adapters. This Oxygen outlet shall be provided where specified below.

Bidder Complies YES_____ NO_____

LOCATION: The Oxygen outlet shall be located in the primary action area switch and outlet console.

Bidder Complies YES_____ NO_____

OXYGEN OUTLET No 3: This outlet latch shall be designed to accept (Ohio) style, quarter turn / quick release adapters. This Oxygen outlet shall be provided where specified below.

Bidder Complies YES_____ NO_____

LOCATION: The Oxygen outlet shall be located in curb side wall, over the squad bench and near the curbside entry door.

Bidder Complies YES_____ NO_____

OXYGEN OUTLET No 4: This outlet latch shall be designed to accept (Ohio) style, quarter turn / quick release adapters. This Oxygen outlet shall be provided where specified below.

Bidder Complies YES_____ NO_____

LOCATION: The aforementioned Oxygen outlet shall be located in ceiling panel over the primary patients' head/chest area. Access to the outlet shall be free of obstructions created by surrounding appliances.

Bidder Complies YES_____ NO_____

MAIN OXYGEN CYLINDER RESTRAINT No 1: One user supplied H-size compressed, medical gas cylinder shall be carried and secured, vertically inside the left Rear exterior compartment. A rust free cylinder rack with (2) heavy duty steel rings and locking bolts shall be installed and shall be type tested to AMD Test 003 Oxygen Tank Retention system Test. The cylinder valve shall also be visible and accessible from the inside through a clear polycarbonate door.

Bidder Complies YES_____ NO_____

CYLINDER TYPE: This rack shall be for a MEDICAL OXYGEN cylinder. The oxygen system input hose shall be suspended over this rack. This input hose shall feature a nonferrous 9/16-18 RH bottle nut and regulator barb. This connection shall comply with the diameter index safety system (DISS) set forth by the Compressed Gas Association (CGA) for safety.

Bidder Complies YES_____ NO_____

CYLINDER RACK LOCATION: The main oxygen cylinder shall be stored in the left front compartment. The cylinder rack shall be through bolted on the back wall, near the right-hand wall of the compartment. The cylinder neck shall be visible and accessible through the viewing window.

Bidder Complies YES_____ NO_____

H SETUP: The oxygen retention bracket shall be set for an "H" size steel or aluminum cylinder.

Bidder Complies YES_____ NO_____

REGULATOR WRENCH: There shall be a cast aluminum main oxygen cylinder wrench installed in the compartment with the main oxygen cylinder rack. The wrench shall include a cable lanyard that secures the wrench to the compartment wall allowing enough length of cable to loosen and tighten the regulator fitting on the customer installed main oxygen cylinder. The wrench shall be stored in place with either a hat channel bracket or Velcro to keep it secured while the vehicle is in motion.

Bidder Complies YES_____ NO_____

MAIN OXYGEN CYLINDER RESTRAINT No 2: One user supplied H-size compressed, medical gas cylinder shall be carried and secured, vertically inside the left Rear exterior compartment. A rust free cylinder rack with (2) heavy duty steel rings and locking bolts shall be installed and shall be type tested to AMD Test 003 Oxygen Tank Retention system Test. The cylinder valve shall also be visible and accessible from the inside through a clear polycarbonate door.

Bidder Complies YES_____ NO_____

CYLINDER TYPE: This rack shall be for a MEDICAL OXYGEN cylinder. The oxygen system input hose shall be suspended over this rack. This input hose shall feature a nonferrous 9/16-18 RH bottle nut and regulator barb. This connection shall comply with the diameter index safety system (DISS) set forth by the Compressed Gas Association (CGA) for safety.

Bidder Complies YES_____ NO_____

CYLINDER RACK LOCATION: The main oxygen cylinder shall be stored in the left rear compartment. The cylinder rack shall be through bolted to the back wall and near the left wall. The cylinder neck shall be visible and accessible through the viewing window.

Bidder Complies YES_____ NO_____

H SETUP: The oxygen retention bracket shall be set for an "H" size steel or aluminum cylinder.

Bidder Complies YES_____ NO_____

Cylinder Wrench: There shall be a cast aluminum main oxygen cylinder wrench installed in the compartment with the main oxygen cylinder rack. The wrench shall include a cable lanyard that secures the wrench to the compartment wall allowing enough length of cable to loosen and tighten the regulator fitting on the customer installed main oxygen cylinder. The wrench shall be stored in place with either a hat channel bracket or Velcro to keep it secured while the vehicle is in motion.

Bidder Complies YES_____ NO_____

ELECTRONIC OXYGEN SYSTEM SHUT-OFF: An oxygen shut off valve shall be supplied and installed on the "Low pressure" side of the oxygen system. The design intent is to shut off the flow of oxygen

to the oxygen outlets when the outlets are not in service. This shall eliminate oxygen loss at the Outlets, even if the user does not shut off the main valve located on the tank. The oxygen outlets shall be supplied with oxygen when a 12-volt switch labeled "Electric O2" is switched into the ON position. The switch shall send voltage to a solenoid valve with a 100% duty cycle rating. The valve body shall be made of a nonferrous metal and shall be cleaned for medical oxygen use. Oxygen shall flow through an orifice with a minimum diameter of 0.156 (5/32) inch. If the valve design is sensitive to flow direction, then the input and output ports shall be clearly and permanently marked by the solenoid valve manufacturer.

MANUAL BY-PASS: A manual fail safe bypass circuit, built into the solenoid valve body. Access to this circuit shall be made with a control knob that is clearly marked on the attendant control panel. The manual bypass control knob shall turn one half turns or less to open the valve completely.

Bidder Complies YES_____ NO_____

VACUUM (SUCTION) PANEL: A variable vacuum regulator and gauge panel shall be installed in the action area control panel. The vacuum regulator shall vary vacuum delivered to a 1200 cubic-centimeter collection jar specified below. The Vacuum gauge shall not be mounted on the collection jar itself.

Bidder Complies YES_____ NO_____

COLLECTION JAR: The suction system shall be equipped with a shatter proof, graduated, 1200cc, transparent collection container. The container shall be regulated through the Sscor panel and installed per manufacturers recommendations. The collection jar shall be retained by a SSCOR retention clip. The retention bracket when installed per directions is SAE J3043 retention testing compliant.

Bidder Complies YES_____ NO_____

COLLECTION JAR PLUMBING: The collection jar shall be connected directly to the regulator panel in the action area console.

Bidder Complies YES_____ NO_____

SUCTION PUMP: The suction pump shall be installed in the left middle compartment, adjacent to the action area panel. The exhaust tube shall be routed to the outside of the vehicle. The pump shall be mounted on rubber vibration isolators to minimize any vibration noise emitted into the patient cabin. The pump shall provide a free air flow of at least 20 liters per minute and achieve a minimum of (11.81 in) Hg vacuum within four seconds after the suction tube is closed. This 49-state pump shall meet or exceed current Federal specification KKK-A-1822.

Bidder Complies YES_____ NO_____

SUCTION PUMP LOCATION: The suction pump shall be installed in the left front middle compartment. The pump shall be mounted to the ceiling of this compartment on rubber vibration isolators.

Bidder Complies YES_____ NO_____

OXYGEN TANK CONTENTS GAUGE: An electronic cylinder pressure gauge with a low-level alarm shall display the main cylinder content.

Bidder Complies YES_____ NO_____

EXTERIOR ENTRY AND COMPARTMENT DOOR HANDLES: Large chrome plated, die cast paddle handles shall be provided to open all module doors. Blind fasteners shall be used to fasten the handles to the door from the backside. Blind Stabilizer pins shall be incorporated on the backside of the handle for alignment purposes. Every paddle handle shall have an isolation gasket between the paddle body and the door skin. All door skin surfaces shall be painted prior to installation of

the handle hardware. All paddles, on single hung and leading double doors shall be locking type and keyed the same (unless specified otherwise). Trailing doors shall: have non-locking paddle handles, mounted on the outside of the door. The Handle shall have a bright chrome like finish mounted into the bright chrome dish. When the door is in the locked position, the handle shall extend when pulled like an automotive handle (free floating) to show the operator that the door is locked and needs to be unlocked to be opened. Systems that utilize a handle that does not free float shall not be accepted as it could bind up the inner hardware and shorten the life of the door operation and timing.

INTERIOR ENTRY AND COMPARTMENT DOOR HANDLES: The interior handle shall be lever type. A Lock/Unlock lever shall be installed below the inside lever handle and be clearly marked Lock/Unlock. The inner chrome plated handle shall have a black powder coated cast aluminum bezel for strength.

Bidder Complies YES_____ NO_____

EMERGENCY INTERIOR LATCH RELEASE: There shall be a red tipped lever to activate a rotary latch at both the top and bottom interior of each patient access door. These shall be used should the door rods become unattached from either the handle or latch assembly. The mechanisms shall be at the point of latching to the Nader pin. An inserted rubber bezel shall be installed into the door panel around the release lever to provide an aesthetic trim to the opening.

Bidder Complies YES_____ NO_____

ASSIST RAIL: This rail shall be naturally accessible to assist persons entering the rear of the module in maintaining their balance. The rail shall be 1 ¼ diameter, 100% stainless steel with gray anti-microbial coating and 18" long. All rail fittings shall be TIG welded to the main rail. The rail shall be located prior to order confirmation. Grab rails that utilize separate, setscrew rail fittings are not reliable and not acceptable.

Bidder Complies YES_____ NO_____

ENTRY DOOR PANELS / WINDOWS / HARDWARE

INTERIOR GRAB HANDLE COLOR: The interior grab handles listed below will be powder coated with anti-microbial, yellow in color.

Bidder Complies YES_____ NO_____

CURB SIDE ENTRY DOOR GRAB HANDLES: The curbside side entry door shall be equipped with a three point, "L" Shaped 1 ¼ diameter, stainless steel with Yellow anti-microbial coating, handicap style grab handles to aid in door closure and entry assistance.

The grab handle shall run horizontally, directly above the inside door latch and bend Ninety-five degrees downward to create a banister (handrail) to aid in vehicle egress. The door handle shall be fastened directly to the horizontal door structure that is welded to the door assembly.

Bidder Complies YES_____ NO_____

REAR ENTRY DOOR GRAB HANDLES: The rear entry doors shall be equipped with a three point, "L" Shaped 1 ¼ diameter, stainless steel with gray anti-microbial coating, handicap style grab handles to aid in door closure and entry assistance.

The grab handle shall run horizontally, directly above the inside door latch and bend Ninety degrees downward to create a banister (handrail) to aid in vehicle egress. The door handle shall be fastened directly to the horizontal door structure that is welded to the door assembly.

Bidder Complies YES_____ NO_____

DOOR PANELS: The inside UPPER door panels shall be made of .080 aluminum diamond plate. The edges of the diamond plate shall be recessed into the door frame extrusion. The center panel shall be upholstery over a smooth aluminum substrate.

Bidder Complies YES_____ NO_____

CURBSIDE LOWER DOOR PANEL: The inside door panel shall be made of .080 aluminum diamond plate. The edges of the diamond plate shall be recessed into the door frame extrusion. The panels shall be fastened to the door frame with stainless steel, #10-32 UNF machine screws threaded into aircraft quality blind fasteners. Each screw shall have an neoprene lock washer.

Bidder Complies YES_____ NO_____

REAR ENTRY DOOR WINDOWS: The rear entry doors shall be equipped with upper windows. The rear entry doors shall have Fold Out windows with a nominal area of 320 square inches. The windows shall have an anodized frame and blind inner mounting ring screws, fastened from the inside. The exterior portion of the frame shall have a full perimeter seal mated against the door skin. All glass shall be tinted safety glass.

Bidder Complies YES_____ NO_____

SIDE ENTRY DOOR WINDOW: The curb side (Right) entry door shall be equipped with an automotive style window. The window will be recessed in a factory stamped opening. The window will be near flush. Window will fold out at bottom for ventilation. All glass shall be tinted safety glass.

Bidder Complies YES_____ NO_____

DAY NIGHT SHADE: There shall be an adjustable from day to night light filtering pleated surface mounted fabric window shade installed on the interior of the module at a selected window. This window shade is adjustable in light filtration. It shall be securely installed to the original manufacturer's instructions. This item is not guaranteed to be compliant to disinfectant requirements for patient treatment areas.

Bidder Complies YES_____ NO_____

TALK THROUGH WINDOW: The Cab to Module communications window shall be provided.

Bidder Complies YES_____ NO_____

LOCKING PIN: The sliding cab to patient area window shall have a locking pin consisting of metal 1/4" pin with a lanyard retainer to keep from losing the pin when not latched. The pin shall be from the driver's side of the window. The pin shall meet or exceed current Federal specification KKK-A-1822.

Bidder Complies YES_____ NO_____

TEMPERATURE CONTROLLED CABINET: A stainless steel enclosure unit shall be supplied and wired 12v to work off chassis batteries. There shall be a computer interface unit to allow the end user to change the preset temperature setting. It shall include a medical key lock for operation. The unit features two individual spaces with separate temperature control capability. The internal dimensions shall for each bay are 10" wide x 9.75" deep x 6.75" high.

Bidder Complies YES_____ NO_____

ACCESSORY LOAD MANAGER: There shall be a Kussmaul 091-96-12 single input load manager installed specifically to control a single device. This shall be for either a temperature-controlled cabinet or a refrigerator (if optioned). The function of this device will allow constant power to be applied to the component and if the chassis batteries fall below 10.7 volts and would put the starting of the chassis engine in jeopardy, power would be discontinued to the above-mentioned device to allow chassis starting to override the component.

Bidder Complies YES_____ NO_____

ACTION AREA LIGHTING: A 12-volt LED light shall be provided directly over the forward, street side work surface. A 12-inch swivel fixture shall be provided. The light shall have an on/off rocker switch on the body of the light housing.

Bidder Complies YES_____ NO_____

LOCATION: The light shall be mounted above the action area.

Bidder Complies YES_____ NO_____

UPHOLSTERY MATERIALS: All padding and upholstered seating shall be covered in 56-ounce vacuum form ready vinyl. Sewn seams in the seat covers and cushions shall be minimized. Upon request, the manufacturer shall be capable of supplying vacuum formed, seamless vinyl covered upholstery. The color shall be color keyed to the laminate color selections made.

SEAT / BACKREST CORE MATERIAL: The vinyl covered foam shall meet current Federal Specification KKK-A-1822. Seat cushions shall be ergonomically contoured. All core material shall be open cell, high resilience foam.

Bidder Complies YES_____ NO_____

UPHOLSTERY JOINERY TYPE: All padding and upholstered seating shall feature upholstery covered foam that eliminates sewn, visible seams. All cushion corners shall be vinyl wrapped. NO sewn seams are permitted, even at the corners. Seat cushion vinyl shall be pre-formed to the cushion shape to eliminate ALL visible seams. Seat cushions with welting/piping and sewn corner seams are not acceptable since blood and other liquid form biological discharge can penetrate the seam holes and reside in the foam. All vinyl surfaces shall be pulled tight against the foam, utilizing a hard density substrate backing board. Loose fitting vinyl coverings are not acceptable.

Bidder Complies YES_____ NO_____

FULL CUSHIONS: The post and wheel cups normally placed on the squad bench for secondary stretchers shall be DELETED in favor of full seat cushions without cutouts. The seat cushions shall be the same size as the squad bench lid and WITHOUT cutouts. The user chooses to use a backboard in lieu of a stretcher for a secondary patient.

Bidder Complies YES_____ NO_____

HEAD PROTECTION - CURB SIDE ACCESS DOOR: A seamless pad specifically designed to protect the head during egress is required. The pad shall consist of a two-inch thick foam sheet over a high-density substrate backing board and covered in seamless vinyl upholstery.

Bidder Complies YES_____ NO_____

HEAD PROTECTION - REAR ACCESS DOORS: A seamless pad specifically designed to protect the head during egress is required and shall comply with current Federal Specification KKK-A-1822. The pad shall consist of a two-inch thick foam sheet over a high-density substrate backing board and covered in seamless vinyl upholstery.

Bidder Complies YES_____ NO_____

PAINT

100% PAINT FILM COVERAGE: All stages of primer and paint shall cover all surfaces. Hinge mating surfaces on the doors and jambs shall be painted. Bare aluminum and primer only preparation is not acceptable under door hinges. Doors shall be painted without actuation handles installed and doors removed from body. Paint film thickness to be no less than 4.1 mil thickness.

PAINT SYSTEM TYPE: The paint shall be Poly-Urethane type electrostatic application process without exception.

An electrostatic paint spray system is a highly efficient technology for the application of paint to specific work pieces. Negatively charged atomized paint particles and a grounded work piece create an electrostatic field that draws the paint particle to the work piece, minimizing over spray.

For this technology, an ionizing electrode, typically located at the paint gun atomizer tip, causes paint particles to pick up additional electrons and become negatively charged. As the coating is deposited on the work piece, the charge dissipates through the ground and returns to the power supply, completing the circuit. The electrostatic field influences the path of the paint particles. Because the charged particles are attracted to the grounded work piece, over spray is significantly reduced. Paint particles that pass a work piece can be attracted to and deposited on the back of the piece. This phenomenon is known as "wrap."

MECHANICAL ADHESION PROMOTER: The entire module shall be degreased. Degreaser shall be applied to manufacturers recommendations. The module body is to be inspected for flaws and imperfections, and to assure built to order specifications. All surfaces shall be initial sanded with 180 grit paper and all imperfections repaired.

CHEMICAL ADHESION PROMOTER: The module shall be hot-water washed at (140 degrees or greater). Then the aluminum Body shall be treated with Alumiprep 33 acid etching followed by a complete De-ionized body rinse. To ensure all surfaces are cleaned, this step shall be repeated a second time. The entire unit shall be wet coated with Alodine 5700 conversion coating and de ionized water mixed. The module body is baked at 160 degrees to dry.

PRIMER: The module shall then have 2 coats of epoxy primer. The unit is then baked at 140-degree metal temperature for one hour. The module body will then undergo any bodywork or filler that is required at transition(s). A third coat of epoxy primer is applied and cured. The module body will then be final sanded prior to Paint color application. Primer shall be sanded with 320 grit paper to assure flat, orange peel free surface.

TOP-COAT (PAINT): Entire module shall be degreased. Degreaser shall be applied to manufactures recommendations. Two coats of BTLV High Solids color shall be applied.

CLEAR COAT: The clear coat shall be manufactured by the same company as the primer and base coat. Two coats of "clear coat" polyurethane shall be applied per the manufacturer's instructions.

3M POLISHING SYSTEM: Prior to 100% paint cure, the paint on the ambulance body shall be sanded to 1200 grit and polished flat per 3Ms Perfect-It product program for smooth finish.

Bidder Complies YES_____ NO_____

CORROSION: Anti-electrolysis procedures include but are not limited to the following.

- 1) Ensure all bare substrate is dry and free from contamination.
- 2) If bare substrate is showing signs of corrosion/oxidation, sand and remove. Use 180 grit until area is removed.
- 3) Thoroughly blow off areas to remove sand dust and metal shavings.
- 4) Thoroughly degrease to be pre-primed using the wipe-on, wipe-off method with clean white rags. (Use good quality automotive Degreaser)
- 5) Apply Wash primer CR using a brush to all mated surfaces. Allow to flash for 15 minutes at 70 deg F. Mix wash primer CR 1:1 with wash-hardener.
- 6) Apply Urethane caulk to all mated surfaces before assembly to reduce the possibility of corrosion.

EXTERIOR FASTENERS: All screw sites require a replaceable nylon insert for the fastener to thread into. This will isolate the dissimilar metals. Each hole shall be treated with an Electrolysis

Corrosion Control compound prior to installation of the nylon inserts. All exterior screws shall be stainless steel.

PAINT WARRANTY: The conversion paint shall be warranted to the original owner for a period of 7 years, 70,000 miles. The color shift shall be no greater than Delta E of 4.0 with minimum gloss retention of 60 gloss units at twenty-degree angle. Warranty to include a 36-month Corrosion coverage with no exclusions.

Bidder Complies YES_____ NO_____

UNDERCOATING: The bottoms side of the module shall be undercoated, with an exception to any area affected by exhaust system direct heat. Application standards for the undercoating shall be achieved or exceeded as directed by QVM or governing standards.

Bidder Complies YES_____ NO_____

REFLECTIVE TAPE: The module door frames shall have a three-quarter inch (3/4") wide white reflective tape applied to the door frame interior. The tape shall reflect direct light at night to illuminate the outline shape of the door when the door is opened.

Bidder Complies YES_____ NO_____

MAIN BODY COLOR: The main body color shall be oxford white (Ford YZ). The paint finish shall be laid onto the body in a flat, orange peel free, mirror like shine on all four sides.

Bidder Complies YES_____ NO_____

REFLECTIVE / PRISMATIC TAPE: The aforementioned center step shall have a bright, conspicuous prismatic, reflective tape strip applied the rearward facing edge of the step. The tape shall have alternating colors (Red and White). The tape color shall begin and end in Red, and each segment shall measure between seven and nine inches.

Bidder Complies YES_____ NO_____

MAIN BODY COLOR: The main body color shall be determined at a post-award, pre-build conference. The paint finish shall be laid onto the body in a flat, orange peel free, mirror like shine on all four sides.

Bidder Complies YES_____ NO_____

REFLECTIVE TAPE: 88 10" Orange Reflective shall be installed per TN Specs

Bidder Complies YES_____ NO_____

ROOF PAINT: Color match to sides, top finish to exceed industry standard of 5 plus mill thickness.

Bidder Complies YES_____ NO_____

PINSTRIPES: There shall be 1/2 " Reflective Blue pinstripe installed.

Bidder Complies YES_____ NO_____

ROOF PAINT: Color match to sides, top finish to exceed industry standard of 5 plus mill thickness.

Bidder Complies YES_____ NO_____

DRIP RAILS: A bright drip rail shall be provided over each compartment. Full height compartments are exempt because the perimeter roof rail drip rails will cover these compartments.

Bidder Complies YES_____ NO_____

OWNER'S MANUAL: There shall be shipped loose with each completed unit a card with USB flash data file with pertinent information from the build of the vehicle.

Bidder Complies YES_____ NO_____
FLOWMETER

AMBULANCE MARKING PACKAGE: The vehicle shall be supplied with a lettering and "star of life" symbol decal package as described in current Federal specification KKK-A-1822. The "ambulance marking package" is to be shipped loose with the vehicle. The "star of life" symbols shall meet Figure 4 required by KKK-A-1822.

Bidder Complies YES_____ NO_____
FLOWMETER

ROOF STAR OF LIFE: There shall be installed on the module roof a reflective star of life symbol large sized.

Bidder Complies YES_____ NO_____
FLOWMETER

SAFETY PLACARDS: There shall be installed in the chassis cab and patient area descriptive placards in durable materials to remind occupants to fasten seatbelts and to refrain from smoking.

Bidder Complies YES_____ NO_____
FLOWMETER

MANUFACTURER LOGOS: There shall be self-adhesive logos provided and installed for the unit.

Bidder Complies YES_____ NO_____
FLOWMETER

FIRE EXTINGUISHER: Two (5) five-pound A-B-C type fire extinguisher shall be supplied loose with the vehicle on delivery.

Bidder Complies YES_____ NO_____
FLOWMETER

REFLECTOR PACKAGE: Six reflectors shall be supplied on the outside of the module body. The reflectors shall be located at skirt line level and the area size shall be at least 3.75 square inches. Each side shall have one AMBER forward reflector and one RED rearward reflector. The rear of the body shall have one RED reflector per side, located just above the diamond plate kick plate.

Bidder Complies YES_____ NO_____
FLOWMETER

CONVERSION WARRANTY

7 Year, 70,000 mile Mechanical & Electrical including Workmanship.

Bidder Complies YES_____ NO_____
FLOWMETER

7 Year, 70,000-mile Standard Paint Warranty.

Bidder Complies YES_____ NO_____
FLOWMETER

36 Month Paint Coatings Corrosion Warranty.

Bidder Complies YES_____ NO_____
FLOWMETER

20 Year Body Structure Warranty.

Bidder Complies YES_____ NO_____
FLOWMETER

CONCEPTUAL DRAWINGS ONLY: DRAWINGS ARE NOT TO SCALE, ALL MEASURES ARE APPROXIMATE & SUBJECT TO ENGINEERING CHANGE

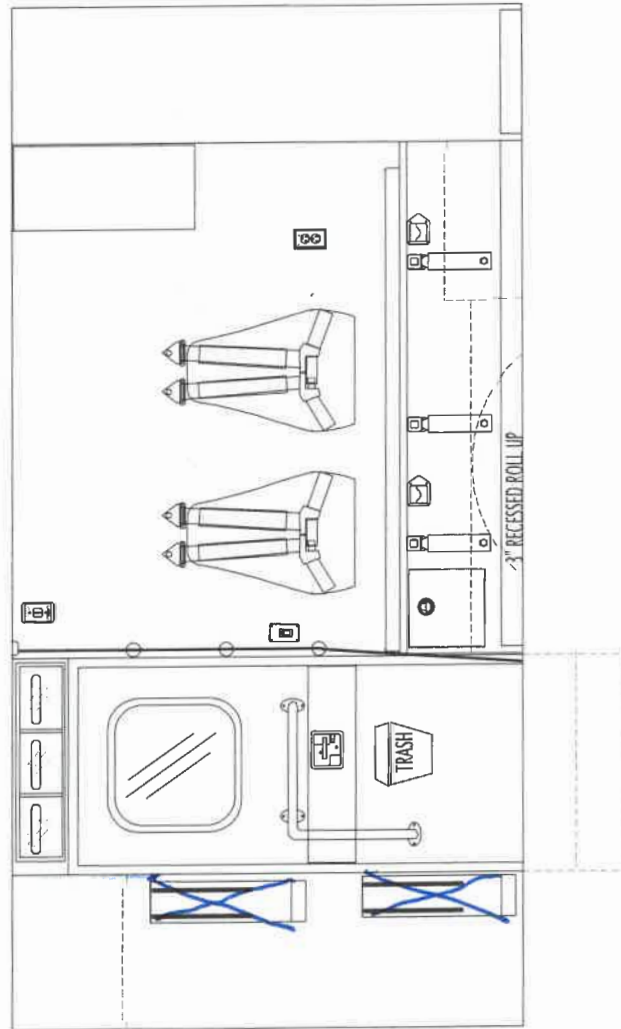
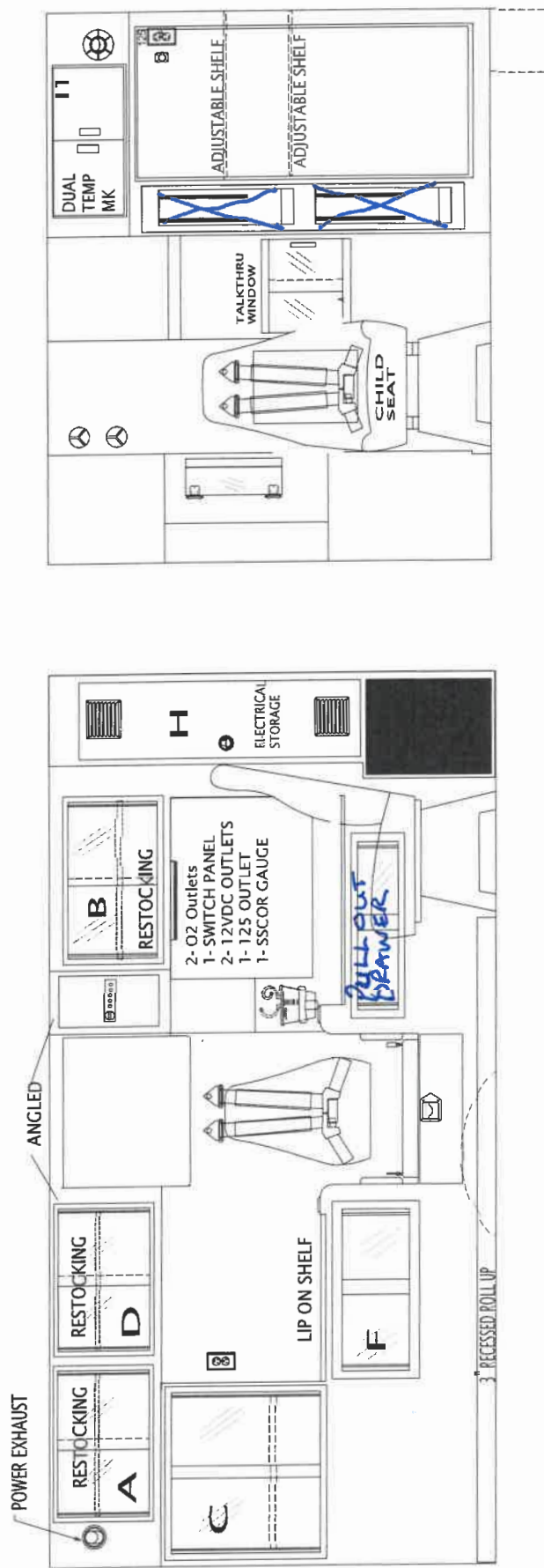

SULLIVAN COUNTY EMS

TITLE Type I, 154", Interior
 DWG.# _____ REV.#0
 Truck# _____

*CONCEPTUAL DRAWINGS
 • Some shown are optional

CONCEPTUAL DRAWINGS ONLY: DRAWINGS ARE NOT TO SCALE, ALL MEASURES ARE APPROXIMATE & SUBJECT TO ENGINEERING CHANGE

154"

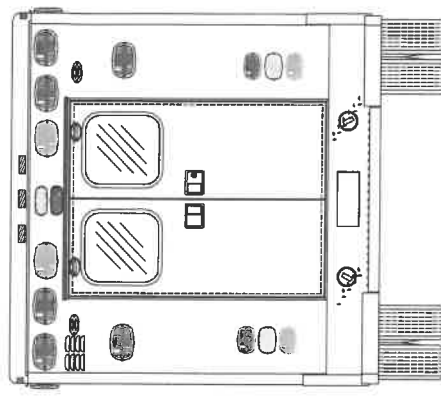
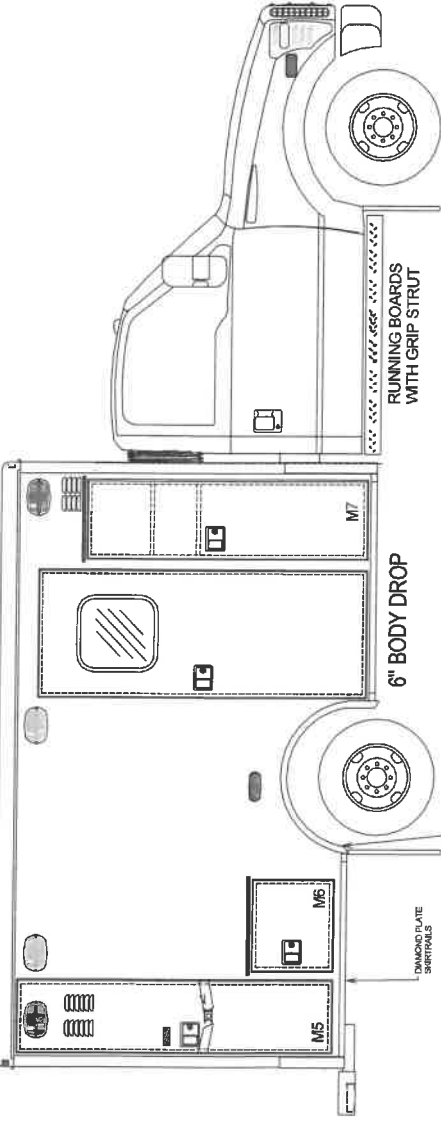
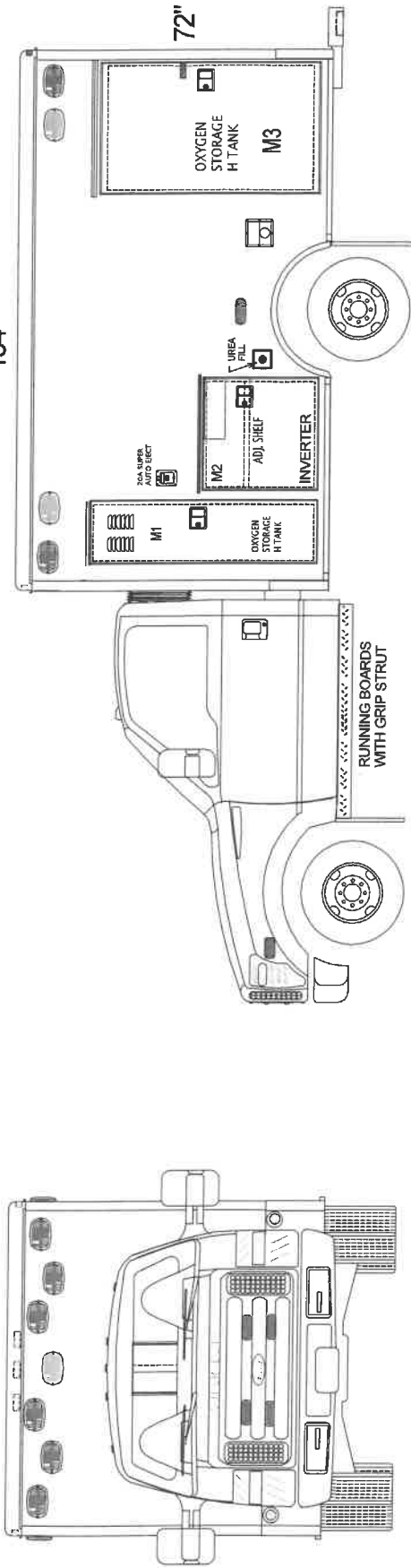

Compartment Dimensions

Comp	Height	Width	Depth
M1	7.4"	22"	19.4"
M2	34.5"	26"	19.4"
M3	74"	34"	19.4"
M5	FULL HEIGHT	20.5"	21"
M6	20.2"	21.5"	19.4"
M7	67.5"	14.3"	N/A
C/S Access	76.8"	31"	N/A
Rear Access	60.5/6"	46.3/4"	N/A

..... DIMENSIONS

..... can change.

SULLIVAN COUNTY EMS

Type 1, 154, Exterior	REV#0
DWG.#	TRUCK#
BY: TLM	BODY #: