 <p>LANCASTER COUNTY SCHOOL DISTRICT Putting our children first</p>	<p>Lancaster County School District</p> <p><i>Invitation for Bid</i></p>	<p>Solicitation Number Solicitation Issue Date Procurement Officer Phone E-Mail Address</p>	<p>202412 1/17/2024 Trevor Hammond, NIGP-CPP, CPPB (803) 416-8828 procurement@lcsd.k12.sc.us</p>
--	---	---	--

DESCRIPTION: **Cafeteria Equipment for Multiple School Locations**

The Term "Offer" Means Your "Bid" or "Proposal".

SUBMIT OFFER BY (Opening Date/Time): **2/8/2024 at 10:00 AM – EST**

See "Deadline for Submission of Offer" provision

QUESTIONS MUST BE RECEIVED BY: **1/24/2024 at 10:00 AM - EST**

See "Questions from Offerors" provision

NUMBER OF COPIES TO BE SUBMITTED: **One (1) original**

Offers must be submitted in a SEALED PACKAGE. Solicitation Number & Opening Date must appear on package exterior.

SUBMIT YOUR OFFER TO THE FOLLOWING ADDRESS:

<p>PHYSICAL & MAILING ADDRESS:</p> <p>Lancaster County School District Attn: Cara Cox 300 South Catawba Street Lancaster, SC 29720 See "Submitting Your Offer" provision</p>

<p>CONFERENCE TYPE: N/A DATE & TIME: LOCATION:</p> <p><small>(As appropriate, see "Conferences - Pre-Bid/Proposal" & "Site Visit" provisions)</small></p>	
<p>AWARD & AMENDMENTS</p>	<p>Award will be posted at the physical address stated above on or about 2/9/2024. The award will be posted at the following web address: https://sites.google.com/lcsd.k12.sc.us/lcsd-procurement/solicitations-awards</p>
<p>You must submit a signed copy of this form with your offer. By submitting a bid or proposal, you agree to be bound by the terms of the solicitation. You agree to hold your offer open for a minimum of sixty (60) calendar days after the opening date.</p>	
<p>NAME OF OFFEROR <small>(Full legal name of business submitting the offer)</small></p>	<p>OFFEROR'S TYPE OF ENTITY: (Check one)</p> <p><input type="checkbox"/> Sole Proprietorship <input type="checkbox"/> Partnership <input type="checkbox"/> Corporate entity (not tax-exempt) <input type="checkbox"/> Tax exempt corporate entity <input type="checkbox"/> Government entity (federal, state, or local) <input type="checkbox"/> Other _____</p> <p><small>(See "Signing your Offer" provision)</small></p>
<p>AUTHORIZED SIGNATURE <small>(Person signing must be authorized to submit binding offer to enter contract on behalf of Offeror named above.)</small></p>	
<p>TITLE <small>(Business title of person signing above)</small></p>	
<p>PRINTED NAME <small>(Printed name of person signing above)</small></p>	
<p>DATE SIGNED</p>	
<p>Instructions regarding Offeror's name: Any award issued will be issued to, and the contract will be formed with, the entity identified as the offeror above. An offer may be submitted by only one legal entity. The entity named as the offeror must be a single and distinct legal entity. Do not use the name of a branch office or a division of a larger entity if the branch or division is not a separate legal entity, <i>i.e.</i>, a separate corporation, partnership, sole proprietorship, etc.</p>	
<p>STATE OF INCORPORATION <small>(If offeror is a corporation, identify the State of Incorporation.)</small></p>	
<p>TAXPAYER IDENTIFICATION NO. <small>(See "Taxpayer Identification Number" provision)</small></p>	

PAGE TWO

(Return Page Two with Your Offer)

HOME OFFICE ADDRESS (Address for offeror's home office / principal place of business)	NOTICE ADDRESS (Address to which all procurement and contract related notices should be sent.) (See "Notice" clause)
	Area Code - Number - Extension Facsimile
	E-mail Address

PAYMENT ADDRESS (Address to which payments will be sent.) (See "Payment" clause)	ORDER ADDRESS (Address to which purchase orders will be sent) (See "Purchase Orders and "Contract Documents" clauses)
___ Payment Address same as Home Office Address ___ Payment Address same as Notice Address (check only one)	___ Order Address same as Home Office Address ___ Order Address same as Notice Address (check only one)

ACKNOWLEDGMENT OF AMENDMENTS
 Offeror acknowledges receipt of amendments by indicating amendment number and its date of issue. (See "Amendments to Solicitation" Provision)

Amendment No.	Amendment Issue Date	Amendment No.	Amendment Issue Date	Amendment No.	Amendment Issue Date	Amendment No.	Amendment Issue Date

DISCOUNT FOR PROMPT PAYMENT (See "Discount for Prompt Payment" clause)	10 Calendar Days (%)	20 Calendar Days (%)	30 Calendar Days (%)	___ Calendar Days (%)
---	----------------------	----------------------	----------------------	-----------------------

Minority Participation: Are you a SC Certified Minority Vendor: Yes No ; If yes, SC Certification # _____
 Are you a Non SC Certified Minority Vendor - Yes No

PREFERENCES - A NOTICE TO VENDORS: On June 16, 2009, the South Carolina General Assembly rewrote the law governing preferences available to in-state vendors, vendors using in-state subcontractors, and vendors selling in-state or US end products. This law appears in Section 11-35-1524 of the South Carolina Code of Laws. A summary of the new preferences is available at www.procurement.sc.gov/preferences. **ALL THE PREFERENCES MUST BE CLAIMED AND ARE APPLIED BY LINE ITEM, REGARDLESS OF WHETHER AWARD IS MADE BY ITEM OR LOT. VENDORS ARE CAUTIONED TO CAREFULLY REVIEW THE STATUTE BEFORE CLAIMING ANY PREFERENCES. THE REQUIREMENTS TO QUALIFY HAVE CHANGED. IF YOU REQUEST A PREFERENCE, YOU ARE CERTIFYING THAT YOUR OFFER QUALIFIES FOR THE PREFERENCE YOU'VE CLAIMED. IMPROPERLY REQUESTING A PREFERENCE CAN HAVE SERIOUS CONSEQUENCES.**

PREFERENCES - ADDRESS AND PHONE OF IN-STATE OFFICE: Please provide the address and phone number for your in-state office in the space provided below. An in-state office is necessary to claim either the Resident Vendor Preference (11-35-1524(C)(1)(i)&(ii)) or the Resident Contractor Preference (11-35-1524(C)(1)(iii)). Accordingly, you must provide this information to qualify for the preference. An in-state office is not required, but can be beneficial, if you are claiming the Resident Subcontractor Preference (11-35-1524(D)).

___ In-State Office Address same as Home Office Address
 ___ In-State Office Address same as Notice Address

Solicitation Outline

- I. **Scope of Solicitation**
- II. **Instructions to Offerors**
 - A. **General Instructions**
 - B. **Special Instructions**
- III. **Scope of Work/Specifications**
- IV. **Information for Offerors to Submit**
- V. **Qualifications**
- VI. **Award Criteria**
- VII. **Terms and Conditions**
 - A. **General**
 - B. **Special**
- VIII. **Bid Schedule**
- IX. **Attachments to Solicitation**
- X. **Minority Participation**

I. SCOPE OF SOLICITATION

The Lancaster County School District is seeking competitive sealed bids from qualified sources for the purchase, delivery and installation of cafeteria equipment for multiple school locations within the district.

Acquire Services & Supplies/Equipment: The purpose of this solicitation is to acquire services and supplies or equipment complying with the enclosed description and/or specifications and conditions.

II. INSTRUCTIONS TO OFFERORS – A. GENERAL INSTRUCTIONS

Definitions, Capitalization, and Headings:

Clause headings used in this solicitation are for convenience only and shall not be used to construe meaning or intent. Even if not capitalized, the following definitions are applicable to all parts of the solicitation, unless expressly provided otherwise.

1. **Amendment** – means a document issued to supplement the original solicitation document.
2. **Board** – means the Lancaster County School District Board of Trustees.
3. **Business** – means any corporation, partnership, individual, sole proprietorship, joint stock company, joint venture, or any other legal entity.
4. **Change Order** - means any written alteration in specifications, delivery point, rate of delivery, period of performance, price, quantity, or other provisions of any contract accomplished by mutual agreement of the parties to the contract.
5. **Contract** - See clause entitled “Contract Documents & Order of Precedence.”
6. **Contract Modification** – means a written order signed by the procurement officer, directing the contractor to make changes which the clause of the contract titled “Changes”, if included herein, authorizes the Procurement Officer to order without the consent of the contractor.
7. **Contractor** - means the offeror receiving an award as a result of this solicitation.
8. **Cover Page** – means the top page of the original solicitation on which the solicitation is identified by number. Offerors are cautioned that amendments may modify information provided on the cover page.
9. **District** – means Lancaster County School District (LCSD)
10. **Offer** – means the bid or proposal submitted in response to this solicitation. The terms “Bid” and “Proposal” are used interchangeably with the term “Offer.”

11. **Offeror** – means the single legal entity submitting the offer. The term “Bidder” is used interchangeably with the term “Offeror.” See bidding provisions entitled “Signing Your Offer” and “Bid/Proposal As Offer To Contract.”
12. **Page Two** – means the second page of the original solicitation, which is labeled Page Two.
13. **Procurement Officer** – means the person, or his successor, identified as such on either the cover page, an amendment, or an award notice. Procurement Officer means the Chief Procurement Officer.
14. **Solicitation** – means this document, including all its parts, attachments, and any amendments.
15. **Subcontractor** – means any person you contract with to perform or provide any part of the work.
16. **Us (or) We** - means the District.
17. **Work** - means all labor, materials, equipment, services, or property of any type, provided or to be provided by the contractor to fulfill the contractor’s obligations under the contract.
18. **You and Your** – means Offeror.

Amendments to Solicitation: (a) The solicitation may be amended at any time prior to opening. All actual and prospective offerors should monitor the following web site for the issuance of amendments: <https://sites.google.com/lcsd.k12.sc.us/lcsd-procurement/solicitations-awards>. (b) Offerors shall acknowledge receipt of any amendment to this solicitation (1) by signing and returning the amendment, (2) by identifying the amendment number and date in the space provided for this purpose on page two, (3) by letter, or (4) by submitting a bid that indicates in some way that the bidder received the amendment. (c) If this solicitation is amended, then all terms and conditions which are not modified remain unchanged.

Because this solicitation is posted electronically, the District may not be aware of all potential offerors, particularly those that attained a copy from this web site or other unknown sources. ***It is the proposer’s responsibility to check this web site periodically to determine if any amendments have been issued. Any amendments issued by the District shall become a formal part of this solicitation.***

Authorized Agent: All authority regarding this procurement is vested solely with the responsible Procurement Officer. Unless specifically delegated in writing, the Procurement Officer is the only government official authorized to bind the government with regard to this procurement or the resulting contract.

Award Notification: Notice regarding any award, cancellation of award, or extension of award will be posted at the location and on the date specified on the cover page or, if applicable, any notice of extension of award. The date and location of posting will be announced at opening. Should the contract resulting from this solicitation have a potential value of one hundred thousand dollars or more, such notice will be sent to all offerors responding to the solicitation and any award will not be effective until the eleventh day after such notice is given.

Bid/Proposal as Offer to Contract: By submitting your bid or proposal, you are offering to enter into a contract with the district. Without further action by either party, a binding contract shall result upon final award. Any award issued will be issued to, and the contract will be formed with, the entity identified as the offeror on the cover page. An offer may be submitted by only one legal entity; “joint bids” are not allowed.

Bid Acceptance Period: In order to withdraw your offer after the minimum period specified on the cover page, you must notify the Procurement Officer in writing.

Bid in English & Dollars: Offers submitted in response to this solicitation shall be in the English language and in US dollars, unless otherwise permitted by the solicitation.

Board as Procurement Agent: The Procurement Officer is an employee of the district acting on behalf of the Lancaster County School District pursuant to the Lancaster County School District Procurement Code. Any contracts awarded as a result of this procurement are between the contractor and the district. The Board is not a party to such contracts, unless and to the extent that the Board is a using district department, and bears no liability for any party’s losses arising out of or relating in any way to the contract.

Certificate of Independent Price Determination:

GIVING FALSE, MISLEADING, OR INCOMPLETE INFORMATION ON THIS CERTIFICATION MAY RENDER YOU SUBJECT TO PROSECUTION UNDER SECTION 16-9-10 OF THE SOUTH CAROLINA CODE OF LAWS AND OTHER APPLICABLE LAWS.

(a) By submitting an offer, the offeror certifies that—

(1) The prices in this offer have been arrived at independently, without, for the purpose of restricting competition, any consultation, communication, or agreement with any other offeror or competitor relating to—

(i) Those prices;

(ii) The intention to submit an offer; or

(iii) The methods or factors used to calculate the prices offered.

(2) The prices in this offer have not been and will not be knowingly disclosed by the offeror, directly or indirectly, to any other offeror or competitor before bid opening (in the case of a sealed bid solicitation) or contract award (in the case of a negotiated solicitation) unless otherwise required by law; and

(3) No attempt has been made or will be made by the offeror to induce any other concern to submit or not to submit an offer for the purpose of restricting competition.

(b) Each signature on the offer is considered to be a certification by the signatory that the signatory—

(1) Is the person in the offeror's organization responsible for determining the prices being offered in this bid or proposal, and that the signatory has not participated and will not participate in any action contrary to paragraphs (a)(1) through (a)(3) of this certification; or

(2)(i) Has been authorized, in writing, to act as agent for the offeror's principals in certifying that those principals have not participated, and will not participate in any action contrary to paragraphs (a)(1) through (a)(3) of this certification [As used in this subdivision (b)(2)(i), the term "principals" means the person(s) in the offeror's organization responsible for determining the prices offered in this bid or proposal];

(ii) As an authorized agent, does certify that the principals referenced in subdivision (b)(2)(i) of this certification have not participated, and will not participate, in any action contrary to paragraphs (a)(1) through (a)(3) of this certification; and

(iii) As an agent, has not personally participated, and will not participate, in any action contrary to paragraphs (a)(1) through (a)(3) of this certification.

(c) If the offeror deletes or modifies paragraph (a)(2) of this certification, the offeror must furnish with its offer a signed statement setting forth in detail the circumstances of the disclosure.

Certification Regarding Debarment and Other Responsibility Matters:

(a)(1) By submitting an offer, offeror certifies, to the best of its knowledge and belief, that-

(i) Offeror and/or any of its Principals-

(A) Are not presently debarred, suspended, proposed for debarment, or declared ineligible for the award of contracts by any state or federal agency;

(B) Have not, within a three-year period preceding this offer, been convicted of or had a civil judgment rendered against them for: commission of fraud or a criminal offense in connection with obtaining, attempting to obtain, or performing a public (federal, state, or local) contract or subcontract; violation of federal or state antitrust statutes relating to the submission of offers; or commission of embezzlement, theft, forgery, bribery, falsification or destruction of records, making false statements, tax evasion, or receiving stolen property; and

(C) Are not presently indicted for, or otherwise criminally or civilly charged by a governmental entity with, commission of any of the offenses enumerated in paragraph (a)(1)(i)(B) of this provision.

(ii) Offeror has not, within a three-year period preceding this offer, had one or more contracts terminated for default by any public (federal, state, or local) entity.

(2) "Principals," for the purposes of this certification, means officers; directors; owners; partners; and, persons having primary management or supervisory responsibilities within a business entity (e.g., general manager; plant manager; head of a subsidiary, division, or business segment, and similar positions).

(b) Offeror shall provide immediate written notice to the Procurement Officer if, at any time prior to contract award, offeror learns that its certification was erroneous when submitted or has become erroneous by reason of changed circumstances.

(c) If offeror is unable to certify the representations stated in paragraphs (a)(1), Offeror must submit a written explanation regarding its inability to make the certification. The certification will be considered in connection with a review of the offeror's responsibility. Failure of the offeror to furnish additional information as requested by the Procurement Officer may render the offeror non-responsible.

(d) Nothing contained in the foregoing shall be construed to require establishment of a system of records in order to render, in good faith, the certification required by paragraph (a) of this provision. The knowledge and information of an offeror is not required to exceed that which is normally possessed by a prudent person in the ordinary course of business dealings.

(e) The certification in paragraph (a) of this provision is a material representation of fact upon which reliance was placed when making award. If it is later determined that the offeror knowingly or in bad faith rendered an erroneous certification, in addition to other remedies available to the district, the Procurement Officer may terminate the contract resulting from this solicitation for default.

Code of Laws Available: The South Carolina Code of Laws, including the Consolidated Procurement Code, is available at <http://www.scstatehouse.gov/code/statmast.php>. The South Carolina Regulations are available at: <http://www.scstatehouse.gov/coderegs/statmast.php>.

Deadline for Submission of Offer: Any offer received after the Procurement Officer of the district or his designee has declared that the time set for opening has arrived, shall be rejected unless the offer has been delivered to the designated purchasing office prior to the bid opening.

Disclosure of Conflicts of Interest or Unfair Competitive Advantage: You warrant and represent that your offer identifies and explains any unfair competitive advantage you may have in competing for the proposed contract and any actual or potential conflicts of interest that may arise from your participation in this competition or your receipt of an award. The two underlying principles are (a) preventing the existence of conflicting roles that might bias a contractor's judgment, and (b) preventing an unfair competitive advantage. If you have an unfair competitive advantage or a conflict of interest, the district may withhold award. Before withholding award on these grounds, an offeror will be notified of the concerns and provided a reasonable opportunity to respond. Efforts to avoid or mitigate such concerns, including restrictions on future activities, may be considered. Without limiting the foregoing, you represent that your offer identifies any services that relate to either this solicitation or the work and that has already been performed by you, a proposed subcontractor, or an affiliated business of either.

District Office Closings: If an emergency or unanticipated event interrupts normal district processes so that offers cannot be received at the district office designated for receipt of bids by the exact time specified in the solicitation, the time specified for receipt of offers will be deemed to be extended to the same time of day specified in the solicitation on the first work day on which normal district processes resume. In lieu of an automatic extension, an amendment may be issued to reschedule bid opening. If district offices are closed at the time a pre-bid or pre-proposal conference is scheduled, an amendment will be issued to reschedule the conference.

Drug Free Work Place Certification: By submitting an offer, contractor certifies that, if awarded a contract, contractor will comply with all applicable provisions of The Drug-free Workplace Act, Title 44, Chapter 107 of the South Carolina Code of Laws, as amended.

Duty to Inquire: Offeror, by submitting an offer, represents that it has read and understands the solicitation and that its offer is made in compliance with the solicitation. Offerors are expected to examine the solicitation thoroughly and should request an explanation of any ambiguities, discrepancies, errors, omissions, or conflicting statements in the solicitation. Failure to do so will be at the offeror's risk. All ambiguities, discrepancies, errors, omissions, or conflicting statements in the Solicitation shall be interpreted to require the better quality or greater quantity of work and/or materials, unless otherwise directed by amendment. Offeror assumes responsibility for any patent ambiguity in the solicitation that offeror does not bring to the District's attention. See clause entitled "Questions from Offerors".

Ethics Certificate: By submitting an offer, the offeror certifies that the offeror has and will comply with, and has not, and will not, induce a person to violate Title 8, Chapter 13 of the South Carolina Code of Laws, as amended (ethics act). The following statutes require special attention: Section 8-13-700, regarding use of official position for financial gain; Section 8-13-705, regarding gifts to influence action of public official; Section 8-13-720, regarding offering money for advice or assistance of public official; Sections 8-13-755 and 8-13-760, regarding restrictions on employment by former public official; Section 8-13-775, prohibiting public official with economic interests from acting on contracts; Section 8-13-790, regarding recovery of kickbacks; Section 8-13-1150, regarding statements to be filed by consultants; and Section 8-13-1342, regarding restrictions on contributions by contractor to candidate who participated in awarding of contract. The district may rescind any contract and recover all amounts expended as a result of any action taken in violation of this provision. If contractor participates, directly or indirectly, in the evaluation or award of public contracts, including without limitation, change orders or task orders regarding a public contract, contractor shall, if required by law to file such a statement, provide the statement required by Section 8-13-1150 to the procurement officer at the same time the law requires the statement to be filed.

Omit Taxes from Price: Do not include any sales or use taxes in your price that the District may be required to pay.

Open Trade Representation: By submitting an Offer, Offeror represents that Offeror is not currently engaged in the boycott of a person or an entity based in or doing business with a jurisdiction with whom South Carolina can enjoy open trade, as defined in SC Code Section 11-35-5300.

Prohibited Communications and Donations: Violation of these restrictions may result in disqualification of your offer, suspension or debarment, and may constitute a violation of law.

- (a) During the period between publication of the solicitation and final award, ***you must not communicate, directly or indirectly, with the District or its employees, agents, or officials regarding any aspect of this procurement activity, unless otherwise approved in writing by the Procurement Officer.*** All communications must be solely with the Procurement Officer.
- (b) You are advised to familiarize yourself with Regulation 19-445.2165, which restricts donations to a governmental entity with whom you have or seek to have a contract. ***You represent that your offer discloses any gifts made, directly or through an intermediary, by you or your named subcontractors to or for the benefit of the District during the period beginning eighteen months prior to the Opening Date.***

Protests: If you are aggrieved in connection with the solicitation or award of the contract, you may be entitled to protest, but only as provided in Section 11-35-4210. To protest a solicitation, you must submit a protest within fifteen days of the date the applicable solicitation document is issued. To protest an award, you must (i) submit notice of your intent to protest within seven business days of the date the award notice is posted, and (ii) submit your actual protest within fifteen days of the date the award notice is posted. Days are calculated as provided in Section 11-35-310(13). Both protests and notices of intent to protest must be in writing and must be received by the appropriate Chief Procurement Officer within the time provided. See clause entitled "Protest- Procurement Department Address". The grounds of the protest and the relief requested must be set forth with enough particularity to give notice of the issues to be decided.

Public Opening: Offers will be publicly opened at the date/time and at the location identified on the cover page, or last amendment, whichever is applicable.

Questions from Offerors: (a) Any prospective offeror desiring an explanation or interpretation of the solicitation, drawings, specifications, etc., must request it in writing. Questions regarding the original solicitation or any amendment must be received by the Procurement Officer no later than fifteen (15) days prior to opening unless an earlier date is stated on the Cover Page. Label any communication regarding your questions with the name of the procurement officer, and the solicitation's title and number. Oral explanations or instructions will not be binding. [See R. 19-445.2042(B)] Any information given a prospective offeror concerning a solicitation will be furnished promptly to all other prospective offerors as an Amendment to the solicitation, if that information is necessary for submitting offers or if the lack of it would be prejudicial to other prospective offerors. See clause entitled "Duty to Inquire." **We will not identify you in our answer to your question.** (b) The District seeks to permit maximum practicable competition. Offerors are urged to advise the Procurement Officer -- as soon as possible -- regarding

any aspect of this procurement, including any aspect of the Solicitation that unnecessarily or inappropriately limits full and open competition.

Rejection/Cancellation: The district may cancel this solicitation in whole or in part. The district may reject any or all bids in whole or in part (Article 5-1710 of the Lancaster County School District's procurement code).

Responsiveness/Improper Offers:

(a) Bid as Specified. Offers for supplies or services other than those specified will not be considered unless authorized by the solicitation.

(b) Multiple Offers. Offerors may submit more than one offer, provided that each offer has significant differences other than price. Each separate offer must satisfy all solicitation requirements. If this solicitation is an Invitation for Bids, each separate offer must be submitted as a separate document. If this solicitation is a Request for Proposals, multiple offers may be submitted as one document, provided that you clearly differentiate between each offer and you submit a separate cost proposal for each offer, if applicable.

(c) Responsiveness. Any offer which fails to conform to the material requirements of the solicitation may be rejected as nonresponsive. Offers which impose conditions that modify material requirements of the solicitation may be rejected. If a fixed price is required, an offer will be rejected if the total possible cost to the district cannot be determined. Offerors will not be given an opportunity to correct any material nonconformity. Any deficiency resulting from a minor informality may be cured or waived at the sole discretion of the Procurement Officer.

(d) Price Reasonableness: Any offer may be rejected if the Procurement Officer determines in writing that it is unreasonable as to price.

(e) Unbalanced Bidding. The district may reject an offer as nonresponsive if the prices bid are materially unbalanced between line items or sub-line items. A bid is materially unbalanced when it is based on prices significantly less than cost for some work and prices which are significantly overstated in relation to cost for other work, and if there is a reasonable doubt that the bid will result in the lowest overall cost to the district even though it may be the low evaluated bid, or if it is so unbalanced as to be tantamount to allowing an advance payment.

(f) Do not submit bid samples or descriptive literature unless expressly requested. Unsolicited bid samples of descriptive literature will not be examined or tested, will not be used to determine responsiveness, and will not be deemed to vary any of the provisions of the solicitation. S.C. Code Ann. Reg. 19-445.2077(D).

Signing Your Offer: Every offer must be signed by an individual with actual authority to bind the offeror. (a) If the offeror is an individual, the offer must be signed by that individual. If the offeror is an individual doing business as a firm, the offer must be submitted in the firm's name, signed by the individual, and state that the individual is doing business as a firm. (b) If the offeror is a partnership, the offer must be submitted in the partnership's name, followed by the words "by its Partner," and signed by a general partner. (c) If the offeror is a corporation, the offer must be submitted in the corporate name, followed by the signature and title of the person authorized to sign. (d) An offer may be submitted by a joint venturer involving any combination of individuals, partnerships, or corporations. If the offeror is a joint venture, the offer must be submitted in the name of the joint venture and signed by every participant in the joint venture in the manner prescribed in paragraphs (a) through (c) above for each type of participant. (e) If an offer is signed by an agent, other than as stated in subparagraphs (a) through (d) above, the offer must state that it has been signed by an agent. Upon request, offeror must provide proof of the agent's authorization to bind the principal.

Disclosure of Your Bid / Proposal & Submitting Confidential Data: (a) According to Section 11-35-410, any person submitting a document in response or with regard to any solicitation or other request must "comply with instructions provided in the solicitation for marking information exempt from public disclosure. Information not marked as required by the applicable instructions may be disclosed to the public." IF YOU IDENTIFY YOUR ENTIRE RESPONSE AS EXEMPT FROM PUBLIC DISCLOSURE, OR IF YOU DO NOT SUBMIT A REDACTED COPY AS REQUIRED, THE DISTRICT MAY, IN ITS SOLE DISCRETION, DETERMINE YOUR BID OR PROPOSAL NONRESPONSIVE AND INELIGIBLE FOR AWARD.

(b) By submitting a response to this solicitation or request, Offeror agrees to the public disclosure of every page, or portion thereof, of every document regarding this solicitation or request that was submitted at any time prior to entering into a contract (including, but not limited to, documents contained in a response, documents submitted to clarify a response, and documents

submitted during negotiations), unless the page, or portion thereof, was redacted and conspicuously marked "Trade Secret" or "Confidential" or "Protected", (2) agrees that any information not redacted and marked, as required by these bidding instructions, as a "Trade Secret" is not a trade secret as defined by the Trade Secrets Act, and (3) agrees that, notwithstanding any claims or markings otherwise, any prices, commissions, discounts, or other financial figures used to determine the award, as well as the final contract amount, are subject to public disclosure.

(c) If your offer includes any information that you claim is exempt from public disclosure, you must submit one complete copy of your offer from which you have removed or concealed such information (the redacted copy). Except for the information removed or concealed, the redacted copy must be identical to your original offer.

(d) Do not mark your entire response (bid, proposal, quote, etc.) as confidential, trade secret, or protected. If only portions of a page are subject to some protection, do not redact the entire page. The redacted copy must reflect the same pagination as the original and show the empty space from which information was redacted. The Procurement Officer must be able to view, search, copy and print the redacted copy without a password. If your response, or any part thereof, is improperly marked as confidential or trade secret or protected, the State may, in its sole discretion, determine it nonresponsive.

(e) On the redacted copy, you must identify the basis of your claim by marking each redaction as follows: You must separately mark with the word "CONFIDENTIAL" every page, or portion thereof, that you redacted and claim as exempt from public disclosure because it is either (1) a trade secret as defined in Section 30-4-40(a)(1) of the Freedom of Information Act, or (2) privileged and confidential, as that phrase is used in Section 11-35-410. You must separately mark with the words "TRADE SECRET" every page, or portion thereof, that you redacted and claim as exempt from public disclosure as a trade secret pursuant to Section 39-8-20 of the Trade Secrets Act. You must separately mark with the word "PROTECTED" every page, or portion thereof, that you redacted and claim as exempt from public disclosure pursuant to Section 11-35-1810. All markings must be conspicuous; use color, bold, underlining, or some other method in order to conspicuously distinguish the mark from the other text.

(f) In determining whether to release documents, the District will detrimentally rely on your redaction and marking of documents, as required by these bidding instructions, as being either "Confidential" or "Trade Secret" or "Protected". By submitting a response, you agree to defend, indemnify and hold harmless the State of South Carolina, its agencies, officers and employees, from every claim, demand, loss, expense, cost, damage or injury, including attorney's fees, arising out of or resulting from withholding information by the State of South Carolina or any of its agencies, that you have redacted or marked as "Confidential" or "Trade Secret" or "Protected". (All references to S.C. Code of Laws.)

Submitting Your Offer or Modification: (a) All prices and notations should be printed in ink or typewritten. Errors should be crossed out, corrections entered and initialed by the person signing the bid. Do not modify the solicitation document itself (including bid schedule). (b) (1) All copies of the offer or modification, and any other documents required to be submitted with the offer shall be enclosed in a sealed, opaque envelope or package. (2) Submit your offer or modification to the address on the Cover Page. (3) The envelope or package must show the time and date specified for opening, the solicitation number, and the name and address of the bidder. If the offer or modification is sent by mail or special delivery service (UPS, Federal Express, etc.), the outermost envelope or wrapper must be labeled "OFFER ENCLOSED" on the face thereof. (c) If you are responding to more than one solicitation, submit each offer in a separate envelope or package. (d) Submit the number of copies indicated on the Cover Page. (e) Facsimile or e-mail offers, modifications, or withdrawals, will not be considered unless authorized by the Solicitation.

Tax Credit For Subcontracting with Disadvantaged Small Businesses: Pursuant to Section 12-6-3350, a taxpayer having a contract with this District who subcontracts with a socially and economically disadvantaged small business is eligible for an income tax credit equal to four percent of the payments to that subcontractor for work pursuant to the contract. The subcontractor must be certified as a socially and economically disadvantaged small business as defined in Section 11-35-5010 and regulations pursuant to it. The credit is limited to a maximum of fifty thousand dollars annually. A taxpayer is eligible to claim the credit for ten consecutive taxable years beginning with the taxable year in which the first payment is made to the subcontractor that qualifies for the credit. After the above ten consecutive taxable years, the taxpayer is no longer eligible for the credit. A taxpayer claiming the credit shall maintain evidence of work performed for the contract by the subcontractor. The credit may be claimed on Form TC-2, "Minority Business Credit." A copy of the subcontractor's certificate from the Governor's Office of Small and Minority Business (OSMBA) is to be attached to the contractor's income tax return. Questions regarding the tax credit and how to file are to be referred to: SC Department of Revenue, Research and Review, Phone: (803) 898-

5786, Fax: (803) 898-5888. Questions regarding subcontractor certification are to be referred to: Governor's Office of Small and Minority Business Assistance, Phone: (803) 734-0657, Fax: (803)734-2498.

Withdrawal or Correction of Offer: Offers may be withdrawn by written notice received at any time before the exact time set for opening. If the solicitation authorizes facsimile offers, offers may be withdrawn via facsimile received at any time before the exact time set for opening. A bid may be withdrawn in person by a bidder or its authorized representative if, before the exact time set for opening, the identity of the person requesting withdrawal is established and the person signs a receipt for the bid. The withdrawal and correction of offers is governed by Article 5-1520 of the Lancaster County School District's procurement code.

II. INSTRUCTIONS TO OFFERORS – B. SPECIAL INSTRUCTIONS

Descriptive Literature - Labeling: Include offeror's name on the cover of any specifications or descriptive literature submitted with your offer.

Descriptive Literature – Required: Your offer must include manufacturer's latest literature showing complete product specifications.

Offering by Item: Offers may be submitted for one or more items.

Preferences - A Notice to Vendors: On June 16, 2009, the South Carolina General Assembly rewrote the law governing preferences available to in-state vendors, vendors using in-state subcontractors, and vendors selling in-state or US end products. This law appears in Section 11-35-1524 of the South Carolina Code of Laws. A summary of the new preferences is available at www.procurement.sc.gov/preferences. ***ALL THE PREFERENCES MUST BE CLAIMED AND ARE APPLIED BY LINE ITEM, REGARDLESS OF WHETHER AWARD IS MADE BY ITEM OR LOT. VENDORS ARE CAUTIONED TO CAREFULLY REVIEW THE STATUTE BEFORE CLAIMING ANY PREFERENCES. THE REQUIREMENTS TO QUALIFY HAVE CHANGED. IF YOU REQUEST A PREFERENCE, YOU ARE CERTIFYING THAT YOUR OFFER QUALIFIES FOR THE PREFERENCE YOU'VE CLAIMED. IMPROPERLY REQUESTING A PREFERENCE CAN HAVE SERIOUS CONSEQUENCES.***

Preferences - SC/US End-Product: Section 11-35-1524 provides a preference to vendors offering South Carolina end-products or US end-products, if those products are made, manufactured, or grown in SC or the US, respectively. An end-product is the tangible project identified for acquisition in this solicitation, including all component parts in final form and ready for the use intended. The terms "made," "manufactured," and "grown" are defined by Section 11-35-1524(A). By signing your offer and checking the appropriate space(s) provided and identified on the bid schedule, you certify that the end-product(s) is either made, manufactured or grown in South Carolina, or other states of the United States, as applicable. Preference will be applied as required by law. Post award substitutions are prohibited. See "Substitutions Prohibited - End Product Preferences" provision.

Preferences - Resident Contractor Preference: To qualify for the RCP, you must maintain an office in this state. An office is a nonmobile place for the regular transaction of business or performance of a particular service which has been operated as such by the bidder for at least one year before the bid opening and during that year the place has been staffed for at least fifty weeks by at least two employees for at least thirty five hours a week each. In addition, you must, at the time you submit your bid, directly employ, or have a documented commitment with, individuals domiciled in South Carolina that will perform services expressly required by the solicitation and your total direct labor cost for those individuals to provide those services must exceed fifty percent of your total bid price. [11-35-1524(C)(1)(iii)] Upon request by the procurement officer, you must identify the persons domiciled in South Carolina that will perform the services involved in the procurement upon which you rely in qualifying for the preference, the services those individuals are to perform, and documentation of the your labor cost for each person identified. If requested, your failure to provide this information promptly will be grounds to deny the preference (and, potentially, for other enforcement action).

Preferences - Resident Subcontractor Preference: To qualify for this preference, You must meet the following requirements. (1) You must -- at the time you submit your bid -- have a documented commitment from a single proposed first tier subcontractor to perform some portion of the services expressly required by the solicitation. (2) The subcontractor -- at the time you submit your bid -- must directly employ, or have a documented commitment with, individuals domiciled in South Carolina that will perform services expressly required by the solicitation and the total direct labor cost to the subcontractor for those individuals to provide those services exceeds, as applicable, either twenty percent for a 2% preference or forty percent of bidder's total bid price for a 4% preference. (3) You must identify the subcontractor that will perform the work, the work the subcontractor is to perform, and your factual basis for concluding that the subcontractor's work constitutes the required percentage of the work to be performed in the procurement. [11-35-1524(D)] You can stack this preference, i.e., earn another 2% or 4% preference for each additional qualifying subcontractor, but the preference is capped. [11-35-1524(D)(4), (E)(7)] Upon request by the procurement officer, you must identify the persons domiciled in South Carolina that are to perform the services involved in the procurement upon which you rely in qualifying for the preference, the services those individuals are to perform, the employer of those persons, your relationship with the employer, and documentation of the subcontractor's labor cost for each person identified. If requested, your failure to provide this information promptly will be grounds to deny the preference (and, potentially, for other enforcement action). YOU WILL NOT RECEIVE THE PREFERENCE UNLESS YOU SPECIFY WHETHER YOUR ARE CLAIMING THE 2% OR 4% PREFERENCE AND YOU PROVIDE THE INFORMATION REQUIRED BY ITEM (3) ABOVE.

Preferences - Resident Vendor Preference: To qualify for the RVP, you must maintain an office in this state. An office is a non-mobile place for the regular transaction of business or performance of a particular service which has been operated as such by the bidder for at least one year before the bid opening and during that year the place has been staffed for at least fifty weeks by at least two employees for at least thirty five hours a week each. In addition, you must either: (1) maintain at a location in South Carolina at the time of the bid an inventory of expendable items which are representative of the general type of commodities for which the award will be made and which have a minimum total value, based on the bid price, equal to the lesser of fifty thousand dollars [\$50,000] or the annual amount of the contract; or (2) be a manufacturer headquartered and having an annual payroll of at least one million dollars in South Carolina and the end product being sold is either made or processed from raw materials into a finished end product by that manufacturer or its affiliate (as defined in Section 1563 of the Internal Revenue Code).

Protest – Procurement Department Address: Any protest must be addressed to the Chief Procurement Officer, Lancaster County School District, and submitted in writing (a) by email to trevor.hammond@lcsd.k12.sc.us, (b) by facsimile at 803-286-4865, or (c) by post or delivery to 300 South Catawba Street, Lancaster, SC 29720.

Site Visit – By Appointment: Appointment for a site visit may be made by contacting Angela McCrorey at 803-416-8014.

Unit Prices Required: Unit price to be shown for each item.

III. SCOPE OF WORK / SPECIFICATIONS

Objective: The Lancaster County School District is seeking competitive sealed bids from qualified sources for cafeteria equipment for multiple school locations within the district. The makes and models listed are the only approved brands of equipment the District is willing to accept. Alternates will not be considered.

Minimum Specifications: Refer to Appendix A for manufacturer's specifications.

Buford High School – Items #1 and #2 must be delivered and have full installation to include all electrical connections. Both items #1 and #2 must be delivered between June 3 and June 27, 2024:

1. Utility Brand 25" Single Section, Pass-Thru, Reach-In Hot Food Cabinet, Stainless Steel Exterior and Interior;

Model #PT-HC-25-SS-2G-2S-D with options & accessories:

- ½ height stainless doors on front and ½ height glass doors in the rear
- Stainless steel back, top, and bottom
- Mounted on 6" front locking casters in lieu of legs
- 12 pair of Universal pan slides

Electrical Specifications: 208V

Quantity: 2

2. Utility Brand 25" Single Section, Pass-Thru, Reach-In Refrigerator, Stainless Steel Exterior and Interior;

Model #PT-R-25-SS-2G-2S-D with options & accessories:

- ½ height stainless doors on front and ½ height glass doors in the rear
- Stainless steel back, top, and bottom
- Mounted on 6" front locking casters in lieu of legs
- 12 pair of Universal pan slides

Electrical Specifications: 115V

Quantity: 2

A.R. Rucker Middle School - Items #3 and #4 must be delivered and have full installation to include all electrical connections. Both items #3 and #4 must be delivered between June 3 and June 27, 2024:

3. Utility Brand 25" Single Section, Pass-Thru, Reach-In Hot Food Cabinet, Stainless Steel Exterior and Interior;

Model #PT-HC-25-SS-2G-2S-D with options & accessories:

- ½ height stainless doors on front and ½ height glass doors in the rear
- Stainless steel back, top, and bottom
- Mounted on 6" front locking casters in lieu of legs
- 12 pair of Universal pan slides

Electrical Specifications: 115V

Quantity: 2

4. Utility Brand 25" Single Section, Pass-Thru, Reach-In Refrigerator, Stainless Steel Exterior and Interior;

Model #PT-R-25-SS-2G-2S-D with options & accessories:

- ½ height stainless doors on front and ½ height glass doors in the rear
- Stainless steel back, top, and bottom
- Mounted on 6" front locking casters in lieu of legs
- 12 pair of Universal pan slides

Electrical Specifications: 115V

Quantity: 2

Lancaster High School – must be delivered and set in place:

5. Southbend Convection Oven SL-Series; Electric Double Deck; Model #SLES/20TC with accessories:

- TC - Touchscreen Controls
- Ventless Design
- Stainless steel rear jacket
- 6" Casters, swivel with front locks
- Stainless steel doors

Electrical Specifications: 208V/60 Hz/1-phase

Quantity: 2

Delivery/Performance Location – Purchase Order: After award, all deliveries shall be made and all services provided to the location specified by the district's purchase order.

Delivery locations:

- **Buford High School**, 4290 Tabernacle Road, Lancaster, SC 29720
- **A.R. Rucker Middle School**, 422 Old Dixie Road, Lancaster, SC 29720
- **Lancaster High School**, 325 Woodland Drive, Lancaster, SC 29720

Contractor must contact the Director of Nutrition and Foodservices, Angela McCrorey @ 803-416-8014 to schedule delivery(s).

1. Equipment must be delivered and fully installed in the case of the Hot Food Cabinets and Refrigerators between June 3 and June 27, 2024 for Buford High School and A.R. Rucker Middle School. Equipment for Lancaster High School can be delivered prior to June 27, 2024 if ready. The district anticipates purchase order(s) will be issued on or before 2/20/2024. **All items shall be delivered within the vendor's stated lead time as noted on the bid schedule. The district must approve any shipment after the stated lead time has passed and reserves the right to cancel such purchase order(s) with no penalty to the district.**
2. All deliveries must be FOB Destination freight prepaid, Inside Delivery. No tailgate deliveries will be accepted. The term FOB Destination freight prepaid, Inside Delivery shall mean delivered, unloaded and brought inside to the district's designated receiving site with all charges for transportation and unloading paid by the contractor. **These charges are to be included in the price of the product, not invoiced separately.** Any claim for loss or damages shall be between the contractor and the carrier.
3. All deliveries shall be made between the hours of 8:00 a.m. and 3:30 p.m., Monday through Friday, excluding holidays and special summer hours.
4. Contracted vendor must accompany delivery(s) to each location.
5. The Lancaster County School District shall assume no liability or responsibility for work until after delivery is complete in all respects and accepted by the district. The contractor shall be completely responsible for all terms and conditions in this contract until the above conditions are met.
6. Successful Contractor to deliver and set in place at school. Contractor must contact Director of Nutrition and Foodservices, Angela McCrorey @ 803-416-8014 so the District can remove the old equipment and the District's Facilities Department can be onsite during delivery. District will make all necessary electrical

connections for the ovens only, **unless it would void any warranties**. If warranties would be voided with the District making electrical connections then the Contractor must make all necessary electrical connections.

7. Contractor must make sure the units are operational prior to departing the school facility.
8. Contractor, or broker, will be required to demonstrate all sections and parts of equipment once equipment is fully connected. The demonstration is to be scheduled/coordinated with the District's food service representative.
9. Vendor will be responsible for the removal of all packing materials and any other debris from the site. District dumpsters are not to be used as a means of disposal.

District Responsibilities:

1. District will provide all necessary electrical connections for the ovens only prior to delivery of equipment, unless it would void any warranties.
2. District will remove all old equipment before new equipment is installed and put in place, except any items to be reused during new installation.

Operational Manuals: Unless otherwise specified, contractor shall provide one operational manual for each item acquired.

Quality – New: All items and materials must be new. Refurbished or remanufactured items will NOT be accepted.

IV. INFORMATION FOR OFFERORS TO SUBMIT

Information for Offerors to Submit – General: You shall submit a signed Cover Page and Page Two. If you submit your offer electronically, you must upload an image of a signed Cover Page and Page Two. Your offer should include all other information and documents requested in this part and in parts II.B. Special Instructions; III. Scope of Work; V. Qualifications; VIII. Bidding Schedule/Price Proposal; and any appropriate attachments addressed in Part IX. Attachments to Solicitations. You should submit a summary of all insurance policies you have or plan to acquire to comply with the insurance requirements stated herein, if any, including policy types; coverage types; limits, sub-limits, and deductibles for each policy and coverage type; the carrier's A.M. Best rating; and whether the policy is written on an occurrence or claims-made basis.

V. QUALIFICATIONS

Qualifications of Offeror: (1) To be eligible for award, you must have the capability in all respects to perform fully the contract requirements and the integrity and reliability which will assure good faith performance. We may also consider a documented commitment from a satisfactory source that will provide you with a capability. We may consider information from any source at any time prior to award. We may elect to consider (i) key personnel, any predecessor business, and any key personnel of any predecessor business, including any facts arising prior to the date a business was established, and/or (ii) any subcontractor you identify. (2) You must promptly furnish satisfactory evidence of responsibility upon request. Unreasonable failure to supply requested information is grounds for rejection. (3) **Corporate subsidiaries are cautioned that the financial capability of an affiliated or parent company will not be considered in determining financial capability**; however, we may elect to consider any security, e.g. letter of credit, performance bond, parent-company corporate guaranty, that you offer to provide.

Qualifications – Required Information: Submit the following information or documentation for you and for any subcontractor (at any tier level) that you identify pursuant to the clause titled Subcontractor – Identification. Err on the side of inclusion. You represent that the information provided is complete. (a) The general history and experience of the business in providing work of similar size and scope. (b) Information reflecting the current financial position. Include the most current financial statement and financial statements for the last two fiscal years. If the financial statements have been

audited in accordance with the following requirements, provide the audited version of those statements. [Reference Statement of Financial Accounting Concepts No. 5 (FASB, December, 1984), as amended.] (c) A detailed, narrative statement listing the three most recent, comparable contracts (including contact information) which have been performed. For each contract, describe how the supplies or services provided are similar to those requested by this solicitation, and how they differ. (d) A list of every business for which supplies or services substantially similar to those sought with this solicitation have been provided, at any time during the past three years. (e) A list of every South Carolina public body for which supplies or services have been provided at any time during the past three years, if any. (f) List of failed projects, suspensions, debarments, and significant litigation.

Subcontractor – Identification: If you intend to subcontract, at any tier level, with another business for any portion of the work and that portion either (1) exceeds 10% of your cost, (2) involves access to any “government information,” as defined in the clause entitled “Information Security - Definitions,” if included, or (3) otherwise involves services critical to your performance of the work (err on the side of inclusion), your offer must identify that business and the work which they are to perform.

Identify potential subcontractors by providing the business name, address, phone, taxpayer identification number, and point of contact. In determining your responsibility, the District may contact and evaluate your proposed subcontractors.

VI. AWARD CRITERIA

Award by Lot: Award will be made by complete lot(s).

Award to Multiple Offerors: Award may be made to more than one Offeror.

Unit Price Governs: In determining award, unit prices will govern over extended prices unless otherwise stated.

VII. TERMS AND CONDITIONS – A. GENERAL

Assignment, Novation, and Change of Name, Identity, or Structure: (a) Contractor shall not assign this contract, or its rights, obligations, or any other interest arising from this contract, or delegate any of its performance obligations, without the express written consent of the responsible procurement officer. The foregoing restriction does not apply to a transfer that occurs by operation of law (e.g., bankruptcy; corporate reorganizations and consolidations, but not including partial asset sales). Notwithstanding the foregoing, contractor may assign monies receivable under the contract provided that the District shall have no obligation to make payment to an assignee until thirty (30) days after contractor (not the assignee) has provided the responsible procurement officer with (i) proof of the assignment, (ii) the identity (by contract number) of the specific District contract to which the assignment applies, and (iii) the name of the assignee and the exact address or account information to which assigned payments should be made. (b) If contractor amends, modifies, or otherwise changes its name, its identity (including its trade name), or its corporate, partnership, or other structure, or its FEIN, contractor shall provide the procurement officer prompt written notice of such change. (c) Any name change, transfer, assignment, or novation is subject to the conditions and approval required by Regulation 19-44.2180, which does not restrict transfers by operation of law.

Bankruptcy - General: (a) Notice. In the event the contractor enters into proceedings relating to bankruptcy, whether voluntary or involuntary, the contractor agrees to furnish written notification of the bankruptcy to the district. This notification shall be furnished within two (2) days of the initiation of the proceedings relating to the bankruptcy filing. This notification shall include the date on which the bankruptcy petition was filed, the identity of the court in which the bankruptcy petition was filed, and a listing of all district contracts against which final payment has not been made. This obligation remains in effect until final payment under this contract. (b) Termination. This contract is voidable and subject to immediate termination by the district upon the contractor’s insolvency, including the filing of proceedings in bankruptcy.

Choice-of-Law: The agreement, any dispute, claim, or controversy relating to the agreement, and all the rights and obligations of the parties shall, in all respects, be interpreted, construed, enforced and governed by and under the laws of the State of South Carolina, except its choice of law rules. As used in this paragraph, the term "Agreement" means any transaction or agreement arising out of, relating to, or contemplated by the solicitation.

Contract Documents & Order of Precedence: (a) Any contract resulting from this solicitation shall consist of the following documents: (1) a Record of Negotiations, if any, executed by you and the Procurement Officer, (2) the solicitation, as amended, (3) documentation of clarifications or discussions of an offer, if applicable (4) your offer (5) any statement reflecting the District's final acceptance (a/k/a "award"), and (6) purchase orders. These documents shall be read to be consistent and complimentary. Any conflict among these documents shall be resolved by giving priority to these documents in the order listed above. (b) The terms and conditions of documents (1) through (5) above shall apply notwithstanding any additional or different terms and conditions in any other document, including without limitation. (i) a purchase order or other instrument submitted by the District (ii) any invoice or other document submitted by Contractor or (iii) any privacy policy, terms of use, or end user agreement. Except as otherwise allowed herein, the terms and conditions of all such documents shall be void and of no effect. (c) No contract, license, or other agreement containing contractual terms and conditions will be signed by the District. Any document(s) signed or otherwise agreed to by persons other than the Procurement Officer shall be void and of no effect.

Discount for Prompt Payment: (a) Discounts for prompt payment will not be considered in the evaluation of offers. However, any offered discount will form a part of the award, and will be taken if payment is made within the discount period indicated in the offer by the offeror. As an alternative to offering a discount for prompt payment in conjunction with the offer, offerors awarded contracts may include discounts for prompt payment on individual invoices. (b) In connection with any discount offered for prompt payment, time shall be computed from the date of the invoice. If the contractor has not placed a date on the invoice, the due date shall be calculated from the date the designated billing office receives a proper invoice, provided the district annotates such invoice with the date of receipt at the time of receipt. For the purpose of computing the discount earned, payment shall be considered to have been made on the date that appears on the payment check or, for an electronic funds transfer, the specified payment date. When the discount date falls on a Saturday, Sunday, or legal holiday when federal government offices are closed and government business is not expected to be conducted, payment may be made on the following business day.

Disputes: (a) Choice-of-Forum. All disputes, claims, or controversies relating to the agreement shall be resolved exclusively by the Chief Procurement Officer in accordance with the district's procurement code, or in the absence of jurisdiction, only in the Court of Common Pleas for, or a federal court located in the State of South Carolina. Contractor agrees that any act by the Government regarding the agreement is not a waiver of either the Government's sovereign immunity or the Government's immunity under the Eleventh Amendment of the United States Constitution. As used in this paragraph, the term "Agreement" means any transaction or agreement arising out of, relating to, or contemplated by the solicitation. (b) Service of Process. Contractor consents that any papers, notices, or process necessary or proper for the initiation or continuation of any disputes, claims, or controversies relating to the agreement; for any court action in connection therewith; or for the entry of judgment on any award made, may be served on contractor by certified mail (return receipt requested) addressed to contractor at the address provided as the notice address on page two or by personal service or by any other manner that is permitted by law, in or outside South Carolina. Notice by certified mail is deemed duly given upon deposit in the United States mail.

Equal Opportunity: Contractor is referred to and shall comply with all applicable provisions, if any, of Title 41, Part 60 of the Code of Federal Regulations, including but not limited to Sections 60-1.4, 60-4.2, 60-4.3, 60-250.5(a), and 60-741.5(a), which are hereby incorporated by reference.

False Claims: According to the S.C. Code of Laws § 16-13-240, "a person who by false pretense or representation obtains the signature of a person to a written instrument or obtains from another person any chattel, money, valuable security, or other property, real or personal, with intent to cheat and defraud a person of that property is guilty" of a crime.

Fixed Pricing Required: Any pricing provided by contractor shall include all costs for performing the work associated with that price. Except as otherwise provided in this solicitation, contractor's price shall be fixed for the duration of this contract, including option terms. This clause does not prohibit contractor from offering lower pricing after award.

- Price(s) shall include overhead, profit, insurance, rental equipment, power tools, travel, fuel, fuel surcharges, delivery, set-up charges, taxes, etc. The district shall not honor any hidden charges.

No Indemnity or Defense: Any term or condition is void to the extent it requires the district to indemnify, defend, or pay attorney's fees to anyone for any reason.

Notice: (a) After award, any notices shall be in writing and shall be deemed duly given (1) upon actual delivery, if delivery is by hand, (2) upon receipt by the transmitting party of automated confirmation or answer back from the recipient's device if delivery is by telex, telegram, facsimile, or electronic mail, or (3) upon deposit into the United States mail, if postage is prepaid, a return receipt is requested, and either registered or certified mail is used. (b) Notice to contractor shall be to the address identified as the notice address on page two. Notice to the district shall be to the Procurement Office address on the cover page. Either party may designate a different address for notice by giving notice in accordance with this paragraph.

Open Trade: During the contract term, including any renewals or extensions, Contractor will not engage in the boycott of a person or an entity based in or doing business with a jurisdiction with whom South Carolina can enjoy open trade, as defined in SC Code Section 11-35-5300.

Payment & Interest: (a) The District shall pay the Contractor, after the submission of proper invoices or vouchers, the prices stipulated in this contract for supplies delivered and accepted or services rendered and accepted, less any deductions provided in this contract. Unless otherwise specified herein, including the purchase order, payment shall not be made on partial deliveries accepted by the district. (b) Notwithstanding any other provision, payment shall be made in accordance with S.C. Code Section 11-35-45, or Chapter 6 of Title 29 (real property improvements) when applicable, which provides the Contractor's exclusive means of recovering any type of interest from the Owner. Contractor waives imposition of an interest penalty unless the invoice submitted specifies that the late penalty is applicable. Except as set forth in this paragraph, the District shall not be liable for the payment of interest on any debt or claim arising out of or related to this contract for any reason. (c) Amounts due to the District shall bear interest at the rate of interest established by the South Carolina Comptroller General pursuant to Section 11-35-45 ("an amount not to exceed fifteen percent each year"), as amended, unless otherwise required by Section 29-6-30. (d) Any other basis for interest, including but not limited to general (pre- and post-judgment) or specific interest statutes, including S.C. Code Ann. Section 34-31-20, are expressly waived by both parties. If a court, despite this agreement and waiver, requires that interest be paid on any debt by either party other than as provided by items (b) and (c) above, the parties further agree that the applicable interest rate for any given calendar year shall be the lowest prime rate as listed in the first edition of the Wall Street Journal published for each year, applied as simple interest without compounding. (e) The District shall have all of its common law, equitable and statutory rights of set-off.

- All invoices for payment of purchases of goods or services shall be delivered to the Lancaster County School District's office.
- All payment for purchases of goods and services shall be paid by the district within thirty (30) days after the acceptance of the goods or services and proper invoice, whichever is received later.

Publicity: Contractor shall not publish any comments or quotes by district employees, or include the district in either news releases or a published list of customers, without the prior written approval of the Procurement Officer.

Purchase Orders: Contractor shall not perform any work prior to the receipt of a purchase order from the district. The district shall order any supplies or services to be furnished under this contract by issuing a purchase order. Purchase orders may be used to elect any options available under this contract, e.g., quantity, item, delivery date, payment method, but are subject to all terms and conditions of this contract. Purchase orders may be electronic. No particular form is required. An order placed pursuant to the purchasing card provision qualifies as a purchase order.

- Purchase order number must be clearly stated on each carton or package, shipping ticket, invoice and any/all other information related to the order.

Survival of Obligations: The parties' rights and obligations which, by their nature, would continue beyond the termination, cancellation, rejection, or expiration of this contract shall survive such termination, cancellation, rejection, or expiration, including, but not limited to, the rights and obligations created by the following clauses: Indemnification - Third Party Claims, Intellectual Property Indemnification, and any provisions regarding warranty or audit.

Taxes: Any tax the contractor may be required to collect or pay upon the sale, use or delivery of the products shall be paid by the District, and such sums shall be due and payable to the contractor upon acceptance. Any personal property taxes levied after delivery shall be paid by the District. It shall be solely the District's obligation, after payment to contractor, to challenge the applicability of any tax by negotiation with, or action against, the taxing authority. Contractor agrees to refund any tax collected, which is subsequently determined not to be proper and for which a refund has been paid to contractor by the taxing authority. In the event that the contractor fails to pay, or delays in paying, to any taxing authorities, sums paid by the District to contractor, contractor shall be liable to the District for any loss (such as the assessment of additional interest) caused by virtue of this failure or delay. Taxes based on Contractor's net income or assets shall be the sole responsibility of the contractor.

Termination Due to Unavailability of Funds: Payment and performance obligations for succeeding fiscal periods shall be subject to the availability and appropriation of funds therefor. When funds are not appropriated or otherwise made available to support continuation of performance in a subsequent fiscal period, the contract shall be canceled. In the event of a cancellation pursuant to this paragraph, contractor will be reimbursed the resulting unamortized, reasonably incurred, nonrecurring costs. Contractor will not be reimbursed any costs amortized beyond the initial contract term.

Third Party Beneficiary: This contract is made solely and specifically among and for the benefit of the parties hereto, and their respective successors and assigns, and no other person will have any rights, interest, or claims hereunder or be entitled to any benefits under or on account of this contract as a third party beneficiary or otherwise.

Waiver: The district does not waive any prior or subsequent breach of the terms of the contract by making payments on the contract, by failing to terminate the contract for lack of performance, or by failing to strictly or promptly insist upon any term of the contract. Only the Chief Procurement Officer has actual authority to waive any of the district's rights under this contract. Any waiver must be in writing.

VII. TERMS AND CONDITIONS – B. SPECIAL

Changes: (1) Contract Modification. By a written order, at any time, and without notice to any surety, the Procurement Officer may, subject to all appropriate adjustments, make changes within the general scope of this contract in any one or more of the following:

- (a) drawings, designs, or specifications, if the supplies to be furnished are to be specially manufactured for the District in accordance therewith;
- (b) method of shipment or packing;
- (c) place of delivery;
- (d) description of services to be performed;
- (e) time of performance (i.e., hours of the day, days of the week, etc.); or,
- (f) place of performance of the services. Subparagraphs (a) to (c) apply only if supplies are furnished under this contract. Subparagraphs (d) to (f) apply only if services are performed under this contract.

(2) Adjustments of Price or Time for Performance. If any such change increases or decreases the contractor's cost of, or the time required for, performance of any part of the work under this contract, whether or not changed by the order, an adjustment shall be made in the contract price, the delivery schedule, or both, and the contract modified in writing accordingly. Any adjustment in contract price made pursuant to this clause shall be determined in accordance with the Price Adjustment Clause

of this contract. Failure of the parties to agree to an adjustment shall not excuse the contractor from proceeding with the contract as changed, provided that the District promptly and duly make such provisional adjustments in payment or time for performance as may be reasonable. By proceeding with the work, the contractor shall not be deemed to have prejudiced any claim for additional compensation, or an extension of time for completion.

(3) Time Period for Claim. Within 30 days after receipt of a written contract modification under Paragraph (1) of this clause, unless such period is extended by the Procurement Officer in writing, the contractor shall file notice of intent to assert a claim for an adjustment. Later notification shall not bar the contractor's claim unless the District is prejudiced by the delay in notification.

(4) Claim Barred After Final Payment. No claim by the contractor for an adjustment hereunder shall be allowed if notice is not given prior to final payment under this contract.

Compliance with Laws: During the term of the contract, contractor shall comply with all applicable provisions of laws, codes, ordinances, rules, regulations, and tariffs.

Contract Limitations: No sales may be made pursuant to this contract for any item or service that is not expressly listed. No sales may be made pursuant to this contract after expiration of this contract. Violation of this provision may result in termination of this contract and may subject contractor to suspension or debarment.

Contractor's Liability Insurance – General: (a) Without limiting any of the obligations or liabilities of Contractor, Contractor shall procure from a company or companies lawfully authorized to do business in South Carolina and with a current A.M. Best rating of no less than A: VII, and maintain for the duration of the contract, insurance against claims for injuries to persons or damages to property which may arise from or in connection with the performance of the work and the results of that work by the contractor, his agents, representatives, employees or subcontractors.

(b) Coverage shall be at least as broad as:

(1) Commercial General Liability (CGL): Insurance Services Office (ISO) Form CG 00 01 12 07 covering CGL on an "occurrence" basis, including products- completed operations, personal and advertising injury, with limits no less than \$1,000,000 per occurrence. If a general aggregate limit applies, the general aggregate limit shall be twice the required occurrence limit. This contract shall be considered to be an "insured contract" as defined in the policy.

(2) Auto Liability: ISO Form Number CA 00 01 covering any auto (Code 1), or if Contractor has no owned autos, hired, (Code 8) and non-owned autos (Code 9), with limits no less than \$1,000,000 per accident for bodily injury and property damage.

(3) Worker's Compensation: As required by the State of South Carolina, with Statutory Limits, and Employer's Liability Insurance with limit of no less than \$1,000,000 per accident for bodily injury or disease.

(c) Every applicable Using Governmental Unit, and the officers, officials, employees and volunteers of any of them, must be covered as additional insureds on the CGL policy with respect to liability arising out of work or operations performed by or on behalf of the Contractor including materials, parts or equipment furnished in connection with such work or operations. General liability coverage can be provided in the form of an endorsement to the Contractor's insurance at least as broad as ISO Form CG 20 10 11 85 or if not available, through the addition of both CG 20 10 and CG 20 37 if a later edition is used.

(d) For any claims related to this contract, the Contractor's insurance coverage shall be primary insurance as respects the State, every applicable Using Governmental Unit, and the officers, officials, employees and volunteers of any of them. Any insurance or self-insurance maintained by the State, every applicable Using Governmental Unit, or the officers, officials, employees and volunteers of any of them, shall be excess of the Contractor's insurance and shall not contribute with it.

(e) Prior to commencement of the work, the Contractor shall furnish the State with original certificates and amendatory endorsements or copies of the applicable policy language effecting coverage required by this section. All certificates are to be received and approved by the State before work commences. However, failure to obtain the required documents prior to the work beginning shall not waive the Contractor's obligation to provide them. The State reserves the right to require complete, certified copies of all required insurance policies, including endorsements required by this section, at any time.

(f) Should any of the above described policies be cancelled before the expiration date thereof, notice will be delivered in accordance with the policy provisions. In addition, the Contractor shall notify the State immediately upon receiving any information that any of the coverages required by this section are or will be changed, cancelled, or replaced.

(g) Contractor hereby grants to the State and every applicable Using Governmental Unit a waiver of any right to subrogation which any insurer of said Contractor may acquire against the State or applicable Using Governmental Unit by virtue of the payment of any loss under such insurance. Contractor agrees to obtain any endorsement that may be necessary to effect this waiver of subrogation, but this provision applies regardless of whether or not the State or Using Governmental Unit has received a waiver of subrogation endorsement from the insurer.

(h) Any deductibles or self-insured retentions must be declared to and approved by the State. The State may require the Contractor to purchase coverage with a lower deductible or retention or provide proof of ability to pay losses and related investigations, claim administration, and defense expenses within the retention.

(i) The State reserves the right to modify these requirements, including limits, based on the nature of the risk, prior experience, insurer, coverage, or other special circumstances.

Contractor's Obligation – General: The contractor shall provide and pay for all materials, tools, equipment, labor and professional and non-professional services, and shall perform all other acts and supply all other things necessary, to fully and properly perform and complete the work. The contractor must act as the prime contractor and assume full responsibility for any subcontractor's performance. The contractor will be considered the sole point of contact with regard to all situations, including payment of all charges and the meeting of all other requirements.

Contractor Personnel: The Contractor shall enforce strict discipline and good order among the Contractor's employees and other persons carrying out the Contract. The Contractor shall not permit employment of unfit persons or persons not skilled in tasks assigned to them.

Default: (a) (1) The District may, subject to paragraphs (c) and (d) of this clause, by written notice of default to the Contractor, terminate this contract in whole or in part if the Contractor fails to:

- (i) Deliver the supplies or to perform the services within the time specified in this contract or any extension;
- (ii) Make progress, so as to endanger performance of this contract (but see paragraph (a)(2) of this clause); or
- (iii) Perform any of the other material provisions of this contract (but see paragraph (a)(2) of this clause).

(2) The District's right to terminate this contract under subdivisions (a)(1)(ii) and (1)(iii) of this clause, may be exercised if the Contractor does not cure such failure within 10 days (or more if authorized in writing by the Procurement Officer) after receipt of the notice from the Procurement Officer specifying the failure.

(b) If the District terminates this contract in whole or in part, it may acquire, under the terms and in the manner the Procurement Officer considers appropriate, supplies or services similar to those terminated, and the Contractor will be liable to the District for any excess costs for those supplies or services. However, the Contractor shall continue the work not terminated.

(c) Except for defaults of subcontractors at any tier, the Contractor shall not be liable for any excess costs if the failure to perform the contract arises from causes beyond the control and without the fault or negligence of the Contractor. Examples of such causes include (1) acts of God or of the public enemy, (2) acts of the District in either its sovereign or contractual capacity, (3) fires, (4) floods, (5) epidemics, (6) quarantine restrictions, (7) strikes, (8) freight embargoes, and (9) unusually severe weather. In each instance the failure to perform must be beyond the control and without the fault or negligence of the Contractor.

(d) If the failure to perform is caused by the default of a subcontractor at any tier, and if the cause of the default is beyond the control of both the Contractor and subcontractor, and without the fault or negligence of either, the Contractor shall not be liable for any excess costs for failure to perform, unless the subcontracted supplies or services were obtainable from other sources in sufficient time for the Contractor to meet the required delivery schedule.

(e) If this contract is terminated for default, the District may require the Contractor to transfer title and deliver to the District, as directed by the Procurement Officer, any (1) completed supplies, and (2) partially completed supplies and materials, parts, tools, dies, jigs, fixtures, plans, drawings, information, and contract rights (collectively referred to as "manufacturing materials" in this clause) that the Contractor has specifically produced or acquired for the terminated portion of this contract. Upon direction of the Procurement Officer, the Contractor shall also protect and preserve property in its possession in which the District has an interest.

(f) The District shall pay contract price for completed supplies delivered and accepted. The Contractor and Procurement Officer shall agree on the amount of payment for manufacturing materials delivered and accepted and for the protection and preservation of the property; if the parties fail to agree, the Procurement Officer shall set an amount subject to the Contractor's

rights under the Disputes clause. Failure to agree will be a dispute under the Disputes clause. The District may withhold from these amounts any sum the Procurement Officer determines to be necessary to protect the District against loss because of outstanding liens or claims of former lien holders.

(g) If, after termination, it is determined that the Contractor was not in default, or that the default was excusable, the rights and obligations of the parties shall, if the contract contains a clause providing for termination for convenience of the District, be the same as if the termination had been issued for the convenience of the District. If, in the foregoing circumstances, this contract does not contain a clause providing for termination for convenience of the District, the contract shall be adjusted to compensate for such termination and the contract modified accordingly subject to the contractor's rights under the Disputes clause.

(h) The rights and remedies of the District in this clause are in addition to any other rights and remedies provided by law or under this contract.

Disposal of Packaging: Contractor shall dispose of all wrappings, crating, and other disposable materials pertaining to this contract at the end of each working day and upon completion of installation.

Illegal Immigration: By signing your offer, you certify that you will comply with the applicable requirements of Title 8, Chapter 14 of the South Carolina Code of Laws and agree to provide to the district upon request any documentation required to establish either: (a) that Title 8, Chapter 14 is inapplicable to you and your subcontractors or sub-subcontractors; or (b) that you and your subcontractors or sub-subcontractors are in compliance with Title 8, Chapter 14. Pursuant to Section 8-14-60, "A person who knowingly makes or files any false, fictitious, or fraudulent document, statement, or report pursuant to this chapter is guilty of a felony, and, upon conviction, must be fined within the discretion of the court or imprisoned for not more than five years, or both." You agree to include in any contracts with your subcontractors language requiring your subcontractors to (a) comply with the applicable requirements of Title 8, Chapter 14, and (b) include in their contracts with the sub-subcontractors language requiring the sub-subcontractors to comply with the applicable requirements of Title 8, Chapter 14.

Indemnification – Third Party Claims – General: Notwithstanding any limitation in this agreement, and to the fullest extent permitted by law, Contractor shall defend and hold harmless Indemnitees for and against any and all suits or claims of any character (and all related damages, settlement payments, attorneys' fees, costs, expenses, losses or liabilities) by a third party which are attributable to bodily injury, sickness, disease or death, or to injury to or destruction of tangible property arising out of or in connection with the goods or services acquired hereunder or caused in whole or in part by any act or omission of contractor, its subcontractors, their employees, workmen, servants, agents, or anyone directly or indirectly employed by them or anyone for whose acts any of them may be liable, regardless of whether or not caused in part by an Indemnitee, and whether or not such claims are made by a third party or an Indemnitee; however, if an Indemnitee's negligent act or omission is subsequently determined to be the sole proximate cause of a suit or claim, the Indemnitee shall not be entitled to indemnification hereunder. Contractor shall be given timely written notice of any suit or claim. Contractor's obligations hereunder are in no way limited by any protection afforded under workers' compensation acts, disability benefits acts, or other employee benefit acts. This clause shall not negate, abridge, or reduce any other rights or obligations of indemnity which would otherwise exist. The obligations of this paragraph shall survive termination, cancelation, or expiration of the parties' agreement. This provision shall be construed fairly and reasonably, neither strongly for nor against either party, and without regard to any clause regarding insurance. As used in this clause, "Indemnitees" means the District, its schools, departments, boards, and all their respective officers, agents and employees.

Licenses and Permits: During the term of the contract, the Contractor shall be responsible for obtaining, and maintaining in good standing, all licenses (including professional licenses, if any), permits, inspections and related fees for each or any such licenses, permits and /or inspections required by the District, county, city or other government entity or unit to accomplish the work specified in this solicitation and the contract.

Material and Workmanship: Unless otherwise specifically provided in this contract, all equipment, material, and articles incorporated in the work covered by this contract are to be new and of the most suitable grade for the purpose intended.

Price Adjustments: (1) Method of Adjustment. Any adjustment in the contract price made pursuant to a clause in this contract shall be consistent with this Contract and shall be arrived at through whichever one of the following ways is the most valid approximation of the actual cost to the Contractor (including profit, if otherwise allowed):

(a) by agreement on a fixed price adjustment before commencement of the pertinent performance or as soon thereafter as practicable;

(b) by unit prices specified in the Contract or subsequently agreed upon;

(c) by the costs attributable to the event or situation covered by the relevant clause, including profit if otherwise allowed, all as specified in the Contract; or subsequently agreed upon;

(d) in such other manner as the parties may mutually agree; or,

(e) in the absence of agreement by the parties, through a unilateral initial written determination by the Procurement Officer of the costs attributable to the event or situation covered by the clause, including profit if otherwise allowed, all as computed by the Procurement Officer in accordance with generally accepted accounting principles, subject to the provisions of Title 11, Chapter 35, Article 17 of the S.C. Code of Laws.

(2) Submission of Price or Cost Data. Upon request of the Procurement Officer, the contractor shall provide reasonably available factual information to substantiate that the price or cost offered, for any price adjustments is reasonable, consistent with the provisions of Section 11-35-1830.

Relationship of the Parties: Neither party is an employee, agent, partner, or joint venturer of the other. Neither party has the right or ability to bind the other to any agreement with a third party or to incur any obligation or liability on behalf of the other party.

Restrictions on Presenting Terms of Use or Offering Additional Services:

(a) Citizens, as well as public employees (acting in their individual capacity), should not be unnecessarily required to agree to or provide consent to policies or contractual terms in order to access services acquired by the district pursuant to this contract (hereinafter "applicable services") or, in the case of public employees, to perform their job duties; accordingly, in performing the work, contractor shall not require or invite any citizen or public employee to agree to or provide consent to any end user contract, privacy policy, or other terms of use (hereinafter "terms of use") not previously approved in writing by the procurement officer. Contractor agrees that any terms of use regarding applicable services are void and of no effect.

(b) Unless expressly provided in the solicitation, public contracts are not intended to provide contractors an opportunity to market additional products and services; accordingly, in performing the work, contractor shall not-for itself or on behalf of any third party-offer citizens or public employees (other than the procurement officer) any additional products or services not required by the contract.

(c) Any reference to contractor in items (a) or (b) also includes any subcontractor at any tier. Contractor is responsible for compliance with these obligations by any person or entity that contractor authorizes to take any action related to the work.

(d) Any violation of this clause is a material breach of contract. The parties acknowledge the difficulties inherent in determining the damage from any breach of these restrictions. Contractor shall pay the district liquidated damages of \$1,000 for each contact with a citizen or end user that violates this restriction.

Shipping/Risk of Loss: F.O.B. Destination, Freight Prepaid. Destination is the District's designated receiving site, or other location, as specified on the purchase order.

Subcontractor Substitution Prohibited – Resident Subcontractor Preference: If you receive an award as a result of the subcontractor preference, you may not substitute any business for the subcontractor upon which you relied to qualify for the preference, unless first approved in writing by the procurement officer. If you violate this provision, the State may terminate your contract for cause and you may be debarred. In addition, the procurement officer may require you to pay the State an amount equal to twice the difference between the price paid by the State and the price offered by the next lowest bidder, unless the substituted subcontractor qualifies for the preference.

Substitutions Prohibited – End Product Preferences: If you receive the award as a result of the South Carolina end product or United States end product preference, you may not substitute a non-qualifying end product for a qualified end product. If you violate this provision, the District may terminate your contract for cause and you may be debarred. In addition,

you shall pay to the District an amount equal to twice the difference between the price paid by the District and your evaluated price for the item for which you delivered a substitute.

Termination for Convenience: (1) Termination. The Procurement Officer may terminate this contract in whole or in part, for the convenience of the District. The Procurement Officer shall give written notice of the termination to the contractor specifying the part of the contract terminated and when termination becomes effective.

(2) Contractor's Obligations. The contractor shall incur no further obligations in connection with the terminated work and on the date set in the notice of termination the contractor will stop work to the extent specified. The contractor shall also terminate outstanding orders and subcontracts as they relate to the terminated work. The contractor shall settle the liabilities and claims arising out of the termination of subcontracts and orders connected with the terminated work. The Procurement Officer may direct the contractor to assign the contractor's right, title, and interest under terminated orders or subcontracts to the District. The contractor must still complete the work not terminated by the notice of termination and may incur obligations as are necessary to do so.

(3) Right to Supplies. The Procurement Officer may require the contractor to transfer title and deliver to the District in the manner and to the extent directed by the Procurement Officer: (a) any completed supplies; and (b) such partially completed supplies and materials, parts, tools, dies, jigs, fixtures, plans, drawings, information, and contract rights (hereinafter called "manufacturing material") as the contractor has specifically produced or specially acquired for the performance of the terminated part of this contract. The contractor shall, upon direction of the Procurement Officer, protect and preserve property in the possession of the contractor in which the District has an interest. If the Procurement Officer does not exercise this right, the contractor shall use best efforts to sell such supplies and manufacturing materials in accordance with the standards of Uniform Commercial Code Section 2-706. Utilization of this Section in no way implies that the District has breached the contract by exercise of the Termination for Convenience Clause.

(4) Compensation. (a) The contractor shall submit a termination claim specifying the amounts due because of the termination for convenience together with cost or pricing data required by Section 11-35-1830 bearing on such claim. If the contractor fails to file a termination claim within one year from the effective date of termination, the Procurement Officer may pay the contractor, if at all, an amount set in accordance with Subparagraph (c) of this Paragraph.

(b) The Procurement Officer and the contractor may agree to a settlement and that the settlement does not exceed the total contract price plus settlement costs reduced by payments previously made by the District, the proceeds of any sales of supplies and manufacturing materials under Paragraph (3) of this clause, and the contract price of the work not terminated;

(c) Absent complete agreement under Subparagraph (b) of this Paragraph, the Procurement Officer shall pay the contractor the following amounts, provided payments agreed to under Subparagraph (b) shall not duplicate payments under this Subparagraph:

(i) contract prices for supplies or services accepted under the contract;

(ii) costs reasonably incurred in performing the terminated portion of the work less amounts paid or to be paid for accepted supplies or services;

(iii) reasonable costs of settling and paying claims arising out of the termination of subcontracts or orders pursuant to Paragraph (2) of this clause. These costs must not include costs paid in accordance with Subparagraph (c)(ii) of this paragraph;

(iv) any other reasonable costs that have resulted from the termination. The total sum to be paid the contractor under this Subparagraph shall not exceed the total contract price plus the reasonable settlement costs of the contractor reduced by the amount of payments otherwise made, the proceeds of any sales of supplies and manufacturing materials under Subparagraph (b) of this Paragraph, and the contract price of work not terminated.

(d) Contractor must demonstrate any costs claimed, agreed to, or established under Subparagraphs (b) and (c) of this Paragraph using its standard record keeping system, provided such system is consistent with any applicable Generally Accepted Accounting Principles.

(5) Contractor's failure to include an appropriate termination for convenience clause in any subcontract shall not (i) affect the District's right to require the termination of a subcontract, or (ii) increase the obligation of the District beyond what it would have been if the subcontract had contained an appropriate clause.

Warranty – Standard: Contractor must provide the manufacturer's standard written warranty upon delivery of product. Contractor warrants that manufacturer will honor the standard written warranty provided.

Lot A

Buford High School 4290 Tabernacle Road, Lancaster, SC 29720						
Item #	Description	Lead Time	Quantity	Unit Price	Extended Price	Preference
1	<p>Utility Brand 25" Single Section, Pass-Thru, Reach-In Hot Food Cabinet, Stainless Steel Exterior and Interior Model #PT-HC-25-SS-2G-2S-D with options & accessories:</p> <ul style="list-style-type: none"> • ½ height stainless doors on front and ½ height glass doors in the rear • Stainless steel back, top, and bottom • Mounted on 6" front locking casters in lieu of legs • 12 pair of Universal pan slides <p><i>Electrical Specifications: 208V</i></p>		2	\$	\$	
2	<p>Utility Brand 25" Single Section, Pass-Thru, Reach-In Refrigerator, Stainless Steel Exterior and Interior Model #PT-R-25-SS-2G-2S-D with options & accessories:</p> <ul style="list-style-type: none"> • ½ height stainless doors on front and ½ height glass doors in the rear • Stainless steel back, top, and bottom • Mounted on 6" front locking casters in lieu of legs • 12 pair of Universal pan slides <p><i>Electrical Specifications: 115V</i></p>		2	\$	\$	
2a	Full Installation for items 1 and 2				\$	

Vendor Name: _____

Lot A

A.R. Rucker Middle School 422 Old Dixie Road, Lancaster, SC 29720						
Item #	Description	Lead Time	Quantity	Unit Price	Extended Price	Preference
3	Utility Brand 25" Single Section, Pass-Thru, Reach-In Hot Food Cabinet, Stainless Steel Exterior and Interior Model #PT-HC-25-SS-2G-2S-D with options & accessories: <ul style="list-style-type: none"> • ½ height stainless doors on front and ½ height glass doors in the rear • Stainless steel back, top, and bottom • Mounted on 6" front locking casters in lieu of legs • 12 pair of Universal pan slides Electrical Specifications: 115V		2	\$	\$	
4	Utility Brand 25" Single Section, Pass-Thru, Reach-In Refrigerator, Stainless Steel Exterior and Interior Model #PT-R-25-SS-2G-2S-D with options & accessories: <ul style="list-style-type: none"> • ½ height stainless doors on front and ½ height glass doors in the rear • Stainless steel back, top, and bottom • Mounted on 6" front locking casters in lieu of legs • 12 pair of Universal pan slides Electrical Specifications: 115V		2	\$	\$	
4a	Full installation for items 3 and 4				\$	
Total Bid for Lot A (items 1-4a)					\$	

Vendor Name: _____

Lot B

Lancaster High School 325 Woodland Drive, Lancaster, SC 29720						
Item #	Description	Lead Time	Quantity	Unit Price	Extended Price	Preference
5	Southbend Convection Oven SL-Series; Electric Double Deck Model #SLES/20TC with accessories: <ul style="list-style-type: none"> • TC - Touchscreen Controls • Ventless Design • Stainless steel rear jacket • 6" Casters, swivel with front locks • Stainless steel doors Electrical Specifications: 208V/60 Hz/1-phase		2	\$	\$	
Total Bid for Lot B (item 5)					\$	

**All deliveries must be FOB Destination freight prepaid, Inside Delivery. No tailgate deliveries will be accepted. These charges are to be included in the price of the product, not invoiced separately.*

Vendor Name: _____

List of all Subcontractors by specialty who are expected to perform work to the Prime Contractor:

(1) All subcontractors' bids shall be included in the base bid amount. (2) A prime contractor whose bid is accepted may not substitute a person as subcontractor in place of a subcontractor listed in the original bid, except for showing a satisfactory reason to the District. Request for substitution must be made to the District in writing. (3) If the bidder determines to use his own employees to perform a portion of the work for which he would otherwise be required to list a subcontractor and if the bidder is qualified to perform that work under the terms of the invitation for bids, the bidder shall list himself in the appropriate place in the bid and not subcontract that work except with the approval of the District for good cause shown.

Sub-Contractors:

If you use more than one subcontractor for any trade, please list each individually.

_____ : _____ Bid Amount: \$ _____
Trade Subcontractor's Name – SC License #

_____ : _____ Bid Amount: \$ _____
Trade Subcontractor's Name – SC License #

Vendor Name: _____

IX. ATTACHMENTS TO SOLICITATION

OFFEROR'S CHECKLIST AVOID COMMON BID/PROPOSAL MISTAKES

Review this checklist prior to submitting your bid/proposal. If you fail to follow this checklist, you risk having your bid/proposal rejected.

- Do not include any of your standard contract forms!
- Unless expressly required, do not include any additional boilerplate contract clauses.
- Reread your entire bid/proposal to make sure your bid/proposal does not take exception to any of the district's mandatory requirements.
- Make sure you have properly marked all protected, confidential, or trade secret information in accordance with the instructions entitled: “**Disclosure of Your Bid / Proposal & Submitting Confidential Data**”. Do not mark your entire bid/proposal as confidential, trade secret, or protected! Do not include a legend on the cover stating that your entire response is not to be released!
- Make sure you have properly acknowledged all amendments. Instructions regarding how to acknowledge amendments are outlined in section entitled: “**Instructions to Offerors – A. General Instructions (Amendments to Solicitation)**”.
- Make sure your bid/proposal is signed by a person that is authorized to contractually bind your business.
- Make sure your bid/proposal includes the number of copies requested.
- Make sure you properly mark the outside of your envelope with the bid number, due date, and time.
- Check to ensure your bid/proposal includes everything requested!
 - ❑ Cover Page – completed and signed
 - ❑ Page Two - completed
 - ❑ Bid Schedule – completed (to include name of company in space provided)
 - ❑ Company Profile and Reference Form (if required)
 - ❑ Evidence of Liability Insurance
 - ❑ Bid Bond, Certified Check or Cashier's Check (if required)
 - ❑ Appropriate Number of Copies Requested
- If you have concerns about this solicitation, do not raise those concerns in your response! **After opening, it is too late! If this solicitation includes a pre-bid/proposal conference or a question & answer period, raise your questions as a part of that process!** Please see instructions under the heading “**Instructions to Offerors – A. General Instructions - Questions from Offerors**” and any provisions regarding pre-bid/proposal conferences.

This checklist is included only as a reminder to help offerors avoid common mistakes.
Responsiveness will be evaluated against the solicitation, **not** against this checklist.
You do **not** need to submit this checklist with your response.

X. MINORITY AND WOMAN BUSINESS ENTERPRISE POLICY AND REQUIREMENTS:

a) Statement of Policy:

It is a practice of the Lancaster County School District that discrimination against businesses on the basis of race, color, national origin, and gender is prohibited. No person shall be denied the benefit of, or otherwise discriminated against, on the grounds of race, color, national origin or gender in connection with the award and/or performance of any contract or modification of a contract between a vendor or contractor and the District which contract is paid or is to be paid for, in whole or part, with monetary appropriations of the District. Further, it is the practice of the District to encourage and promote, on an inclusionary basis, contracting opportunities for all business, without regard to race, color, national origin or gender. It is expected that all firms seeking to do business with the Lancaster County School District will comply with this policy.

b) Subcontractor Participation:

The Lancaster County School District, through its contract documents, encourages contractors to utilize minority subcontractors on their projects.

A prime contractor must identify M/WBE utilization expenditures to certified M/WBE subcontractors that perform a commercially useful function in the work of the contract. An M/WBE subcontractor is considered to perform a commercially useful function when it is responsible for the execution of a distinct element of the work of a contract for which the MBE or WBE has the skill and expertise and carries out its responsibilities by actually performing, managing and supervising the work involved.

c) Business Utilization Report:

In order to facilitate an effective monitoring system, each contractor, bidder or offeror must submit a completed and signed Utilization Report with the bid submission which lists the names, addresses and contact persons of the M/WBE and majority owned businesses, if any, to be used in the contract, the type of work each business will perform, the dollar value of the work and the scope of work. The Utilization Report submitted by the contractor shall be submitted as a part of the contract with the Lancaster County School District. If the information contained in the Contractor's Utilization Report changes by the time the contract is executed, the Contractor shall amend the Utilization Report and such amended Utilization Report shall be incorporated into the contract.

Business Enterprise Utilization Report

List all vendors/subcontractors to be used on this project. All MBE's or WBE's proposed for utilization on this project must be certified by the Small and Minority Business Assistance Office through the State of South Carolina according to the criteria of the Lancaster County School District's Minority Business Enterprise Plan.

In column 6 below, please specify ethnic/racial/gender group as follows:

- AABE – African-American Business Enterprise
- HBE – Hispanic Business Enterprise
- ABE – Asian-American Business Enterprise
- FBE – Female Business Enterprise
- MAJ – Majority Business Enterprise

Project Title	W/M Business Enterprise Name	Address	Contact Person(s)	Telephone #	Designation Code

Statement of Intent

We, the undersigned have prepared and submitted all the documents required for this project. We have prepared these documents with a full understanding of the Lancaster County School District's goal to ensure equal opportunities in the proposed work to be undertaken in performance of this project. Specifically the District seeks to encourage and promote on an inclusionary basis contracting opportunities without regard to the race, gender, national origin or ethnicity of the ownership or management of any business and that it is an equal opportunity employer and contracting entity. We certify that the representations contained in the Minority/Women Business Enterprise (M/WBE) Utilization Report, which we have submitted with this solicitation, are true and correct as of this date. We commit to undertake this contract with the Minority/Women Business utilization Report we have submitted, and to comply with all non-discrimination provisions of the Minority/Women Business Enterprise Program in the performance of this contract.

Name: _____
 Signature: _____
 Title: _____
 Date: _____

Appendix A



Quantity: 2

Project _____

Item No. _____

Model No. _____

Quantity _____

CSI No. 114000

REACH-IN HOT FOOD CABINET - ONE SECTION

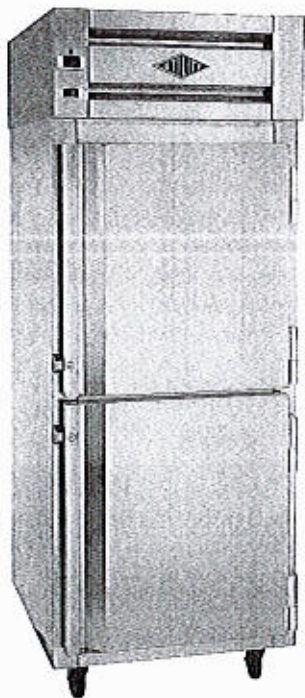

HC-30-SS-2S-D

30" Wide, Stainless Steel Exterior and Interior, half height doors (shown with optional 12" high top-mount)

STANDARD FEATURES:

Construction/Cabinet

- Cabinet specially designed for holding hot food (not a modified refrigerator)
- 100% hi-temp fiberglass insulation for safety, durability and longevity
- Heat resistant, non-conductive phenolic thermal breaker
- Exterior sides – heavy gauge stainless steel
- Exterior back and bottom – heavy gauge galvanized
- Stainless steel top-mount housing
- Stainless steel front, door, rails and top-mount
- Heavy-duty 6" adjustable stainless steel legs
- Fully covered interior with welded radius corners for easy cleaning
- Stainless steel shelf clips and shelf standards
- Four adjustable chrome plated wire shelves per section
- 5" high low-profile top-mount

Doors

- Self-closing door hinges with stay-open feature at 120°
- Standard right hinged door (other configurations available)
- Full-length, one-piece recessed Unigrip™ door handle (solid door models)
- Heavy-duty, built-in security cylinder door lock (solid door models)

Heating System

- Easy to set, top-mounted digital control
- Temperature setpoint memory (keeps setting when power is off)
- Main power switch
- Humidity controlling vent in top of cabinet

Control Systems & Warranty Coverage

- Digital temperature control – easily adjust setpoint between 165-175°F
- Master power switch
- One 9 foot electrical cord
- Warranty: 5 year parts, 1 year labor

OPTIONS & ACCESSORIES:

- Stainless steel back top bottom (specify all that apply)
- Additional chrome wire shelves (specify quantity) _____
- Stainless steel wire shelves in lieu of chrome shelves
- Tray slides (specify quantity) _____
 "L" Type _____ Universal slides 12 "R" Type _____
- Stainless steel curb base (specify 4" or 6" high)
- 6" front locking casters in lieu of legs (no charge)
- 4" front locking casters in lieu of legs
- 6" seismic legs
- Correctional facilities package
- 12" high top-mount

MODEL GUIDE

Model Number	Description
<input checked="" type="checkbox"/> HC-25-SS-1S-D	25" Wide, S/S Exterior and Interior
<input type="checkbox"/> HC-30-SS-1S-D	30" Wide, S/S Exterior and Interior
Options	Model Number Modification
<input checked="" type="checkbox"/> Half Doors	Change "1S" to "2S"
<input checked="" type="checkbox"/> Pass-Thru	Add prefix "PT" to model number
<input type="checkbox"/> Narrow Depth	Change suffix "D" to "N"
<input checked="" type="checkbox"/> Glass Door	Change "S" to "G"

AGENCY APPROVALS:



Intertek



Intertek



REACH-IN HOT FOOD CABINET - ONE SECTION

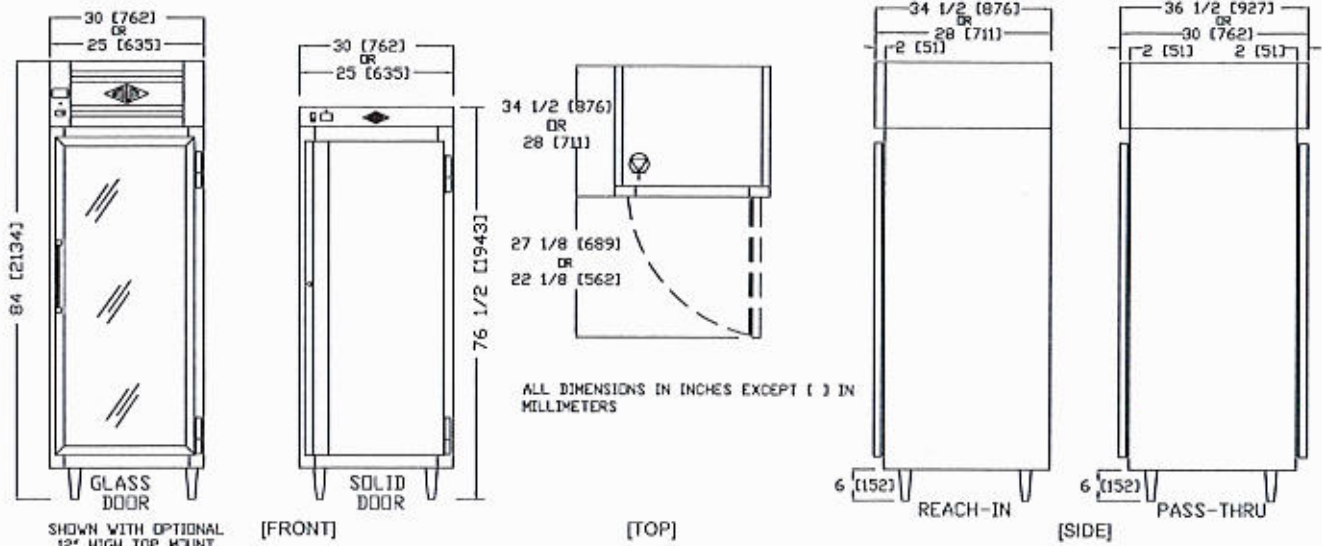

PRODUCT DATA	HC-25 Series Standard Depth	HC-25 Series Narrow Depth	HC-30 Series Standard Depth	HC-30 Series Narrow Depth
KEY DIMENSIONS				
Width (overall)	25.0"	25.0"	30.0"	30.0"
Depth (overall)	34.5"	28.0"	34.5"	28.0"
Depth Pass-Thru Models (overall)	36.5"	30.0"	36.5"	30.0"
Height, with low profile top mount (overall inc. legs)	76.5"	76.5"	76.5"	76.5"
Height, with full height top mount (overall inc. legs)	84.0"	84.0"	84.0"	84.0"
Door Opening (net width)	18.25"	18.25"	23.25"	23.25"
Door Opening (net height)	57.25"	57.25"	57.25"	57.25"
Half Door Opening (net ht)	26.75"	26.75"	26.75"	26.75"
CAPACITY				
Capacity (cu.ft.)	19	15	24	18
Number of Shelves	4	4	4	4
Shelf Area (sq. ft., including bottom)	16	12	20	15
ELECTRICAL				
Voltage (dedicated circuit required)	115 or 208/230	115 or 208/230	115 or 208/230	115 or 208/230
Amperage (115V)	13.0	13.0	13.0	13.0
Amperage (208/230V)	7.2 / 6.5	7.2 / 6.5	7.2 / 6.5	7.2 / 6.5
NEMA Plug Configuration (115V only)*	5-15 P	5-15 P	5-15 P	5-15 P
Wattage	1500	1500	1500	1500
SHIPPING				
Ship Weight (lbs.)	450	360	550	445
Ship Volume, Standard Depth (cu.ft.)	75	66	87	76
Crated Dimensions (87"H)	31"W x 48"D	31"W x 42"D	36"W x 48"D	36"W x 42"D

*208/230V models hardwired

Data is for standard models; options may change specifications.

UTILITY REFRIGERATOR

12160 Sherman Way • North Hollywood, CA 91605
 Telephone: (818) 764-6200 • Fax: (818) 764-6211
www.utilityrefrigerator.com

DUE TO CONTINUOUS PRODUCT IMPROVEMENTS, SPECIFICATIONS ARE SUBJECT TO CHANGE WITHOUT NOTICE.

©/™* Utility Refrigerator



WARNING - This product can expose you to chemicals including Di(2-ethylhexyl)phthalate (DEHP), which is [are] known to the State of California to cause cancer and birth defects or other reproductive harm. For more information go to www.P65Warnings.ca.gov

UR-HC1 | MU



Quantity: 2

 Project _____
 Item No. _____
 Model No. _____
 Quantity _____

CSI No. 114000

REACH-IN REFRIGERATOR - ONE SECTION

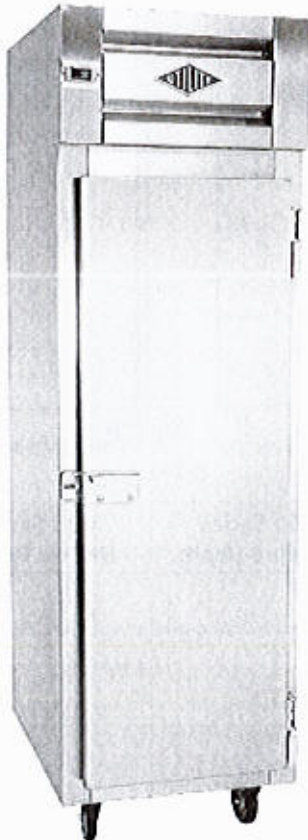

R-25-SS-1S-D
 25" Wide, S/S Exterior and Interior
 (shown with optional correctional package)

MODEL GUIDE

Model Number	Description
<input checked="" type="checkbox"/> R-25-SS-1S-D	25" Wide, S/S Exterior and Interior
<input type="checkbox"/> R-30-SS-1S-D	30" Wide, S/S Exterior and Interior
Options	Model Number Modification
<input type="checkbox"/> Remote Refrigeration	Add suffix "X" to model number
<input checked="" type="checkbox"/> Half Doors	Change "1S" to "2S"
<input checked="" type="checkbox"/> Pass-Thru	Add prefix "PT" to model number
<input type="checkbox"/> Narrow Depth	Change suffix "D" to "N"
<input checked="" type="checkbox"/> Glass Door	Change "1S" to "1G"

STANDARD FEATURES:

Construction/Cabinet

- Exterior front and sides – heavy gauge stainless steel
- Exterior back and bottom – heavy gauge galvanized
- Stainless steel compressor housing
- Stainless steel front, door, and grille
- Heavy-duty 6" adjustable stainless steel legs
- Cabinet body is foamed-in-place minimum 2-1/2" thick polyurethane insulation
- Fully coved interior with welded radius corners for easy cleaning
- Interior LED lighting
- Stainless steel shelf clips and shelf standards
- Four adjustable chrome plated wire shelves per section

Doors

- Self-closing, lift off door hinges with stay open feature at 120°
- Standard right hinged door (other configurations available)
- Full-length, one-piece recessed Unigrip™ door handle (solid door models)
- Heavy-duty, built-in security cylinder door lock (solid door models)
- Energy saving condensate heater around door opening
- Snap-in magnetic door gasket
- Impact-resistant PVC breaker strip

Refrigeration Package

- Expansion valve refrigeration system for superior recovery and temperature pull-down
- Low Pressure control – prevents compressor burnout in case of refrigerant loss
- Top-mounted compressor
- R-513a, low GWP refrigerant for superior temperature recovery and pull-down
- Hot gas condensate evaporator quickly dissipates condensation using zero additional energy
- Receiver tank and service valves – allows reuse of refrigerant and enables rapid pull-down during times of peak demand
- Integrated sight glass – allows technicians to easily detect leaks or moisture without tools

Control Systems & Warranty Coverage

- Digital temperature control – easily adjust setpoint between 35-40°F
- Master power switch
- One 9 foot electrical cord
- Warranty: 5 year compressor, 5 year parts, 1 year labor

OPTIONS & ACCESSORIES:

- Stainless steel back top bottom (specify all that apply)
- Drawers in lieu of lower half door (requires half-door option)
- Additional chrome wire shelves (specify quantity) _____
- Stainless steel wire shelves in lieu of chrome shelves
- Tray slides (specify quantity) _____
 "L" Type _____ Universal slides 12 "R" Type _____
- Digital temperature control & solenoid for remote models
- Refrigerant options for remote models-please specify refrigerant type
- Stainless steel curb base (specify 4" or 6" high)
- Temperature alarm
- 6" front locking casters in lieu of legs (no charge)
- 4" front locking casters in lieu of legs
- 6" seismic legs
- Correctional facilities package
- Top-mounted evaporator coil (std. depth units only)
- Water-cooled condensing unit
- 5" high top-mount (remote compressor models)

AGENCY APPROVALS:



Intertek



Intertek



REACH-IN REFRIGERATOR - ONE SECTION

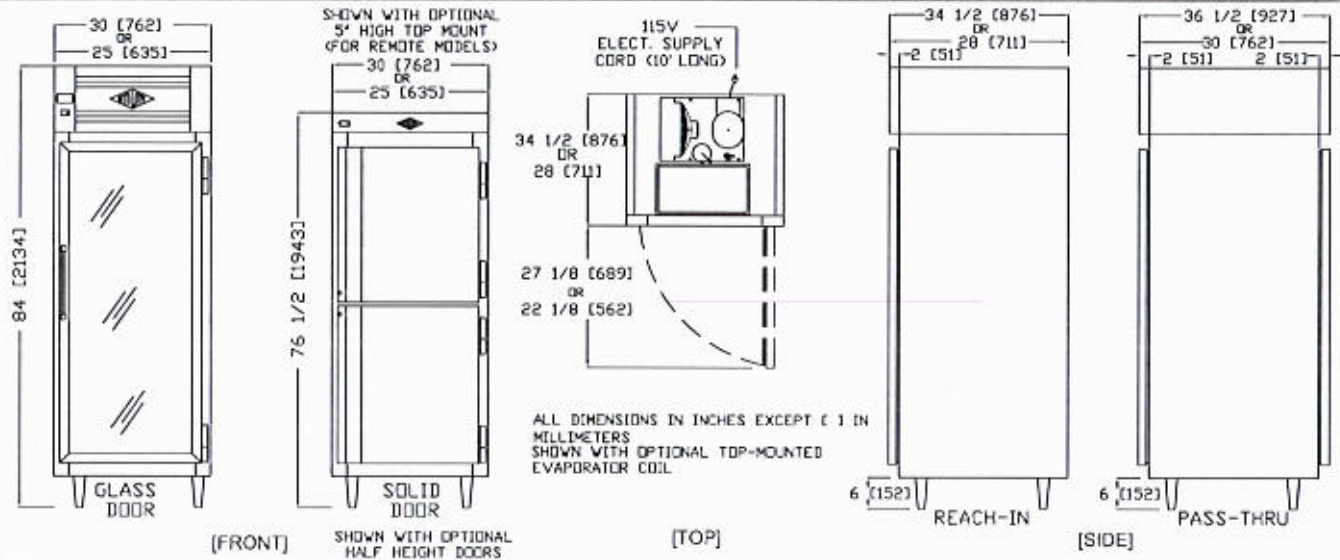

PRODUCT DATA	R-25 Series Standard Depth	R-25 Series Narrow Depth	R-30 Series Standard Depth	R-30 Series Narrow Depth
KEY DIMENSIONS				
Width (overall)	25.0"	25.0"	30.0"	30.0"
Depth (overall)	34.5"	28.0"	34.5"	28.0"
Depth Pass-Thru Models (overall)	36.5"	30.0"	36.5"	30.0"
Height (overall inc. legs)	84.0"	84.0"	84.0"	84.0"
Door Opening (net width)	18.25"	18.25"	23.25"	23.25"
Door Opening (net height)	57.25"	57.25"	57.25"	57.25"
Half Door Opening (net ht.)	26.75"	26.75"	26.75"	26.75"
CAPACITY				
Capacity (cu. ft.)	19	15	24	18
Number of Shelves	4	4	4	4
Shelf Area (sq. ft., including bottom)	16	12	20	15
ELECTRICAL				
Voltage (dedicated circuit required)	115	115	115	115
SOLID DOOR MODELS				
Amperage solid door models (self-contained)	7.3	7.3	7.3	7.3
Amperage solid door models (remote refrigeration)	6.0	6.0	6.0	6.0
BTU requirement*, remote (solid door models)	1440	1395	1575	1495
GLASS DOOR MODELS				
Amperage glass door models (self-contained)	7.3	7.3	9.5	7.3
Amperage glass door models (remote refrigeration)	6.0	6.0	6.8	6.0
BTU requirement*, remote (glass door models)	1942	1880	2553	2103
NEMA Plug Configuration	5-15 P	5-15 P	5-15 P	5-15 P
Horsepower (self-contained)	1/4	1/4	1/4	1/4
SHIPPING				
Ship Weight (lbs.)	500	410	600	495
Ship Volume - Standard Depth (cu. ft.)	75	66	87	76
Crated Dimensions (87"H)	31"W x 48"D	31"W x 42"D	36"W x 48"D	36"W x 42"D

*90°F ambient, 20°F evaporator; 20 max. line length

Data is for standard models; options may change specifications.

UTILITY REFRIGERATOR

12160 Sherman Way • North Hollywood, CA 91605
 Telephone: (818) 764-6200 • Fax: (818) 764-6211
www.utilityrefrigerator.com

DUÉ TO CONTINUOUS PRODUCT IMPROVEMENTS, SPECIFICATIONS ARE SUBJECT TO CHANGE WITHOUT NOTICE.

©/™ Utility Refrigerator



WARNING - This product can expose you to chemicals including Di(2-ethylhexyl)phthalate (DEHP), which is [are] known to the State of California to cause cancer and birth defects or other reproductive harm. For more information go to www.P65Warnings.ca.gov

UR-R1 | MU



Project: _____
 Item No: _____
 Model No: _____
 Quantity: _____

CSI No. 114000

REACH-IN HOT FOOD CABINET - ONE SECTION

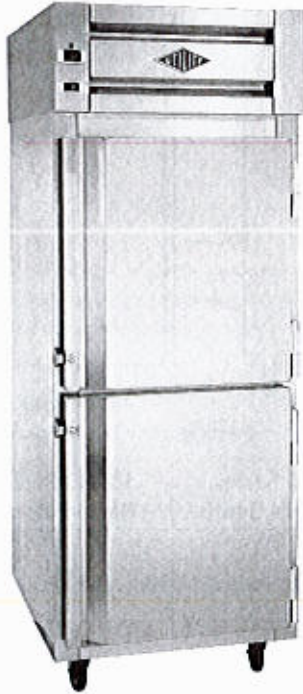

HC-30-SS-2S-D
 30" Wide, Stainless Steel Exterior and Interior, half height doors (shown with optional 12" high top-mount)

STANDARD FEATURES:

Construction/Cabinet

- Cabinet specially designed for holding hot food (not a modified refrigerator)
- 100% hi-temp fiberglass insulation for safety, durability and longevity
- Heat resistant, non-conductive phenolic thermal breaker
- Exterior sides – heavy gauge stainless steel
- Exterior back and bottom – heavy gauge galvanized
- Stainless steel top-mount housing
- Stainless steel front, door, rails and top mount
- Heavy-duty 6" adjustable stainless steel legs
- Fully covered interior with welded radius corners for easy cleaning
- Stainless steel shelf clips and shelf standards
- Four adjustable chrome plated wire shelves per section
- 5" high low-profile top-mount

Doors

- Self-closing door hinges with stay-open feature at 120°
- Standard right hinged door (other configurations available)
- Full-length, one-piece recessed Unigrip™ door handle (solid door models)
- Heavy-duty, built-in security cylinder door lock (solid door models)

Heating System

- Easy to set, top-mounted digital control
- Temperature setpoint memory (keeps setting when power is off)
- Main power switch
- Humidity controlling vent in top of cabinet

Control Systems & Warranty Coverage

- Digital temperature control – easily adjust setpoint between 165-175°F
- Master power switch
- One 9 foot electrical cord
- Warranty: 5 year parts, 1 year labor

OPTIONS & ACCESSORIES:

- Stainless steel back top bottom (specify all that apply)
- Additional chrome wire shelves (specify quantity) _____
- Stainless steel wire shelves in lieu of chrome shelves
- Tray slides (specify quantity)
 "L" Type _____ Universal slides 12 "R" Type _____
- Stainless steel curb base (specify 4" or 6" high)
- 6" front locking casters in lieu of legs (no charge)
- 4" front locking casters in lieu of legs
- 6" seismic legs
- Correctional facilities package
- 12" high top-mount

MODEL GUIDE

Model Number	Description
<input checked="" type="checkbox"/> HC-25-SS-1S-D	25" Wide, S/S Exterior and Interior
<input type="checkbox"/> HC-30-SS-1S-D	30" Wide, S/S Exterior and Interior
Options	Model Number Modification
<input checked="" type="checkbox"/> Half Doors	Change "1S" to "2S"
<input checked="" type="checkbox"/> Pass-Thru	Add prefix "PT" to model number
<input type="checkbox"/> Narrow Depth	Change suffix "D" to "N"
<input checked="" type="checkbox"/> Glass Door	Change "S" to "G"

AGENCY APPROVALS:



Intertek



Intertek



REACH-IN HOT FOOD CABINET - ONE SECTION

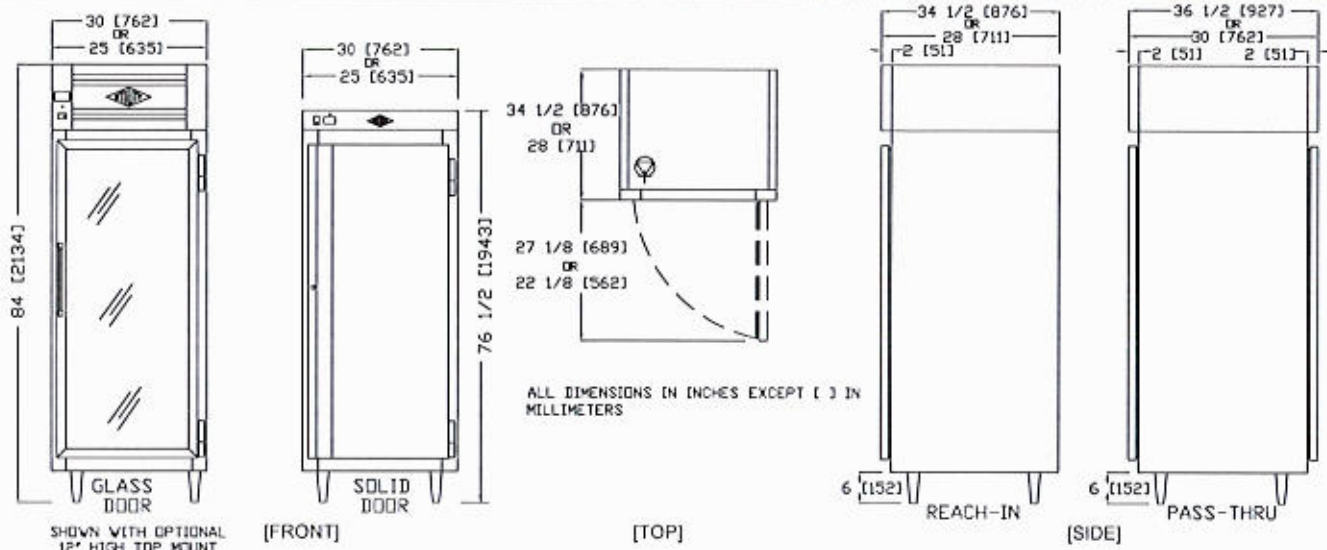

PRODUCT DATA	HC-25 Series Standard Depth	HC-25 Series Narrow Depth	HC-30 Series Standard Depth	HC-30 Series Narrow Depth
KEY DIMENSIONS				
Width (overall)	25.0"	25.0"	30.0"	30.0"
Depth (overall)	34.5"	28.0"	34.5"	28.0"
Depth Pass-Thru Models (overall)	36.5"	30.0"	36.5"	30.0"
Height, with low profile top mount (overall inc. legs)	76.5"	76.5"	76.5"	76.5"
Height, with full height top mount (overall inc. legs)	84.0"	84.0"	84.0"	84.0"
Door Opening (net width)	18.25"	18.25"	23.25"	23.25"
Door Opening (net height)	57.25"	57.25"	57.25"	57.25"
Half Door Opening (net ht.)	26.75"	26.75"	26.75"	26.75"
CAPACITY				
Capacity (cu ft.)	19	15	24	18
Number of Shelves	4	4	4	4
Shelf Area (sq. ft., including bottom)	16	12	20	15
ELECTRICAL				
Voltage (dedicated circuit required)	115 or 208/230	115 or 208/230	115 or 208/230	115 or 208/230
Amperage (115V)	13.0	13.0	13.0	13.0
Amperage (208/230V)	7.2 / 6.5	7.2 / 6.5	7.2 / 6.5	7.2 / 6.5
NEMA Plug Configuration (115V only)*	5-15 P	5-15 P	5-15 P	5-15 P
Wattage	1500	1500	1500	1500
SHIPPING				
Ship Weight (lbs.)	450	360	550	445
Ship Volume, Standard Depth (cu ft.)	75	66	87	76
Crated Dimensions (87" H)	31"W x 48"D	31"W x 42"D	36"W x 48"D	36"W x 42"D

*208/230V models hardwired

Data is for standard models; options may change specifications.

UTILITY REFRIGERATOR

12160 Sherman Way • North Hollywood, CA 91605
 Telephone: (818) 764-6200 • Fax: (818) 764-6211
www.utilityrefrigerator.com

DU TO CONTINUOUS PRODUCT IMPROVEMENTS, SPECIFICATIONS ARE SUBJECT TO CHANGE WITHOUT NOTICE

©/™/® Utility Refrigerator



WARNING - This product can expose you to chemicals including Di(2-ethylhexyl)phthalate (DEHP), which is [are] known to the State of California to cause cancer and birth defects or other reproductive harm. For more information go to www.P65Warnings.ca.gov



Item #4
Quantity: 2

A.R. Rucker Middle School

1/2

Project _____
Item No. _____
Model No. _____
Quantity _____

CSI No. 114000

REACH-IN REFRIGERATOR - ONE SECTION

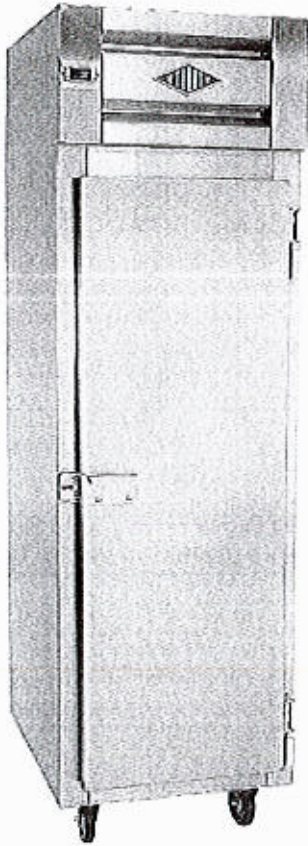

R-25-SS-1S-D
25" Wide, S/S Exterior and Interior
(shown with optional correctional package)

MODEL GUIDE

Model Number	Description
<input checked="" type="checkbox"/> R-25-SS-1S-D	25" Wide, S/S Exterior and Interior
<input type="checkbox"/> R-30-SS-1S-D	30" Wide, S/S Exterior and Interior
Options	Model Number Modification
<input type="checkbox"/> Remote Refrigeration	Add suffix "X" to model number
<input checked="" type="checkbox"/> Half Doors	Change "1S" to "2S"
<input checked="" type="checkbox"/> Pass-Thru	Add prefix "PT" to model number
<input type="checkbox"/> Narrow Depth	Change suffix "D" to "N"
<input checked="" type="checkbox"/> Glass Door	Change "1S" to "1G"

STANDARD FEATURES:

Construction/Cabinet

- Exterior front and sides – heavy gauge stainless steel
- Exterior back and bottom – heavy gauge galvanized
- Stainless steel compressor housing
- Stainless steel front, door, and grille
- Heavy-duty 6" adjustable stainless steel legs
- Cabinet body is foamed-in-place minimum 2-1/2" thick polyurethane insulation
- Fully covered interior with welded radius corners for easy cleaning
- Interior LED lighting
- Stainless steel shelf clips and shelf standards
- Four adjustable chrome plated wire shelves per section

Doors

- Self-closing, lift off door hinges with stay-open feature at 120°
- Standard right hinged door (other configurations available)
- Full-length, one-piece recessed Unigrip™ door handle (solid door models)
- Heavy-duty, built-in security cylinder door lock (solid door models)
- Energy saving condensate heater around door opening
- Snap-in magnetic door gasket
- Impact-resistant PVC breaker strip

Refrigeration Package

- Expansion valve refrigeration system for superior recovery and temperature pulldown
- Low Pressure control – prevents compressor burnout in case of refrigerant loss
- Top-mounted compressor
- R-513a, low GWP refrigerant for superior temperature recovery and pulldown
- Hot gas condensate evaporator quickly dissipates condensation using zero additional energy
- Receiver tank and service valves – allows reuse of refrigerant and enables rapid pulldown during times of peak demand
- Integrated sight glass – allows technicians to easily detect leaks or moisture without tools

Control Systems & Warranty Coverage

- Digital temperature control – easily adjust setpoint between 35-40°F
- Master power switch
- One 9 foot electrical cord
- Warranty: 5 year compressor, 5 year parts, 1 year labor

OPTIONS & ACCESSORIES:

- Stainless steel back top bottom (specify all that apply)
- Drawers in lieu of lower half door (requires half-door option)
- Additional chrome wire shelves (specify quantity) _____
- Stainless steel wire shelves in lieu of chrome shelves
- Tray slides (specify quantity) _____
"L" Type _____ Universal slides 12 "R" Type _____
- Digital temperature control & solenoid for remote models
- Refrigerant options for remote models-please specify refrigerant type
- Stainless steel curb base (specify 4" or 6" high)
- Temperature alarm
- 6" front locking casters in lieu of legs (no charge)
- 4" front locking casters in lieu of legs
- 6" seismic legs
- Correctional facilities package
- Top-mounted evaporator coil (std. depth units only)
- Water-cooled condensing unit
- 5" high top-mount (remote compressor models)

AGENCY APPROVALS:



Intertek



Intertek

UTILITY REFRIGERATOR • 12160 Sherman Way • North Hollywood CA 91605 • 818-764-6200 • Fax: 818-764-6211 • www.utilityrefrigerator.com

©/™/® Utility Refrigerator

UR-R1 | MU



REACH-IN REFRIGERATOR - ONE SECTION

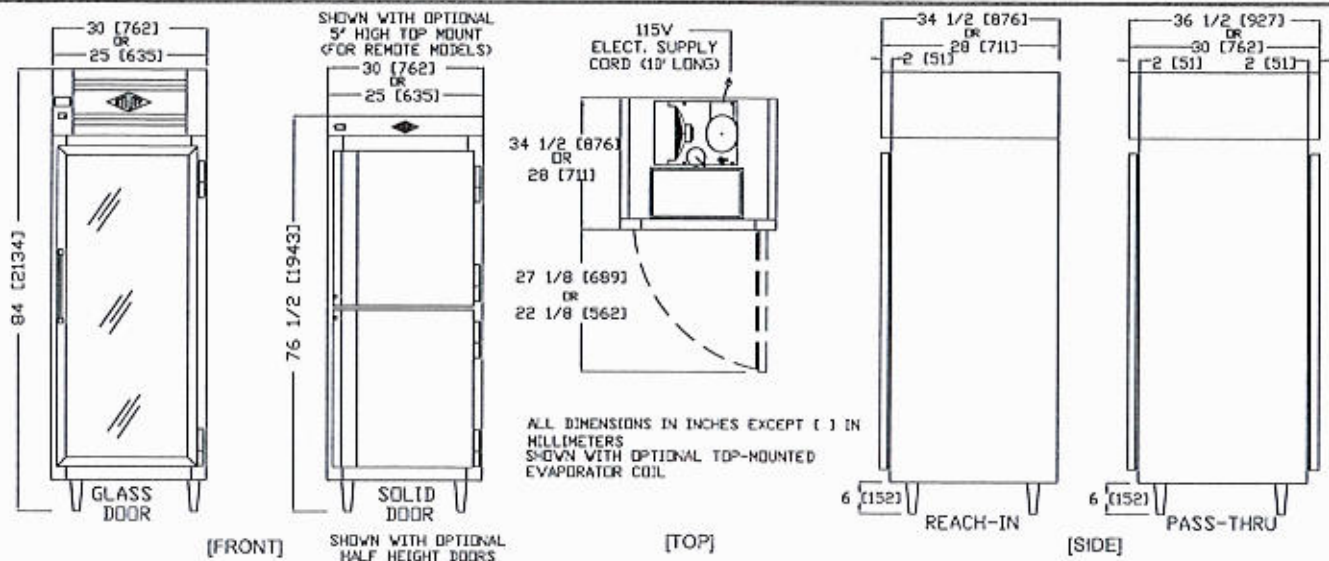

PRODUCT DATA	R-25 Series Standard Depth	R-25 Series Narrow Depth	R-30 Series Standard Depth	R-30 Series Narrow Depth
KEY DIMENSIONS				
Width (overall)	25.0"	25.0"	30.0"	30.0"
Depth (overall)	34.5"	28.0"	34.5"	28.0"
Depth Pass-Thru Models (overall)	36.5"	30.0"	36.5"	30.0"
Height (overall inc. legs)	84.0"	84.0"	84.0"	84.0"
Door Opening (net width)	18.25"	18.25"	23.25"	23.25"
Door Opening (net height)	57.25"	57.25"	57.25"	57.25"
Half Door Opening (net ht.)	26.75"	26.75"	26.75"	26.75"
CAPACITY				
Capacity (cu. ft.)	19	15	24	18
Number of Shelves	4	4	4	4
Shelf Area (sq. ft., including bottom)	16	12	20	15
ELECTRICAL				
Voltage (dedicated circuit required)	115	115	115	115
SOLID DOOR MODELS				
Amperage solid door models (self-contained)	7.3	7.3	7.3	7.3
Amperage solid door models (remote refrigeration)	6.0	6.0	6.0	6.0
BTU requirement*, remote (solid door models)	1440	1395	1575	1495
GLASS DOOR MODELS				
Amperage glass door models (self-contained)	7.3	7.3	9.5	7.3
Amperage glass door models (remote refrigeration)	6.0	6.0	6.8	6.0
BTU requirement*, remote (glass door models)	1942	1880	2553	2103
NEMA Plug Configuration	5-15 P	5-15 P	5-15 P	5-15 P
Horsepower (self-contained)	1/4	1/4	1/4	1/4
SHIPPING				
Ship Weight (lbs.)	500	410	600	495
Ship Volume, Standard Depth (cu. ft.)	75	66	87	76
Crated Dimensions (87"H)	31"W x 48"D	31"W x 42"D	36"W x 48"D	36"W x 42"D

*90°F ambient, 20°F evaporator, 20' max. line length

Data is for standard models; options may change specifications.

UTILITY REFRIGERATOR

12160 Sherman Way • North Hollywood, CA 91605

Telephone: (818) 764-6200 • Fax: (818) 764-6211

www.utilityrefrigerator.com

DUE TO CONTINUOUS PRODUCT IMPROVEMENTS, SPECIFICATIONS ARE SUBJECT TO CHANGE WITHOUT NOTICE

©/™ Utility Refrigerator



WARNING - This product can expose you to chemicals including Di(2-ethylhexyl)phthalate (DEHP), which is [are] known to the State of California to cause cancer and birth defects or other reproductive harm. For more information, go to www.P65Warnings.ca.gov

Item #5
Quantity: 2

Lancaster High School

1/2

Job: _____ Item# _____



SLE20



Take your bake anywhere! New Optional Ventless Internal Catalyst Design.

CONVECTION OVEN SL - SERIES ELECTRIC, DOUBLE DECK

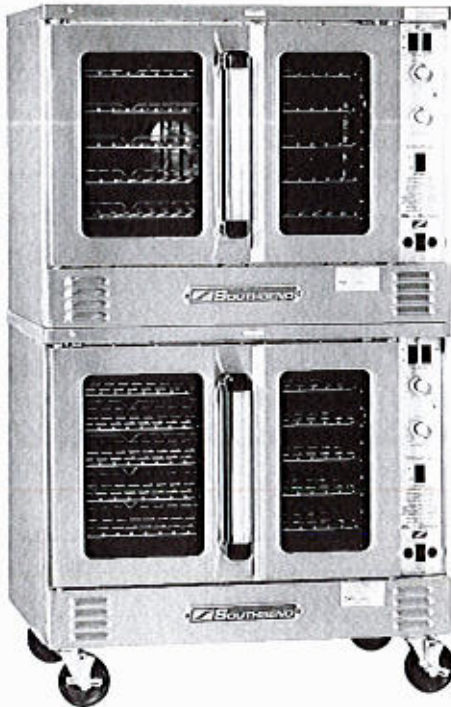

SLES/20SC shown with optional casters

- SLES/20SC
- SLES/20TC
- SLEB/20SC
- SLEB/20TC

Standard Features

- 11 kW high efficiency heating elements
- Available standard and bakery depths
- Double deck convection oven is 64.8" in height
- Patented "plug-in, plug-out" control panel - easy to service
- Slide out control panel for full view servicing
- Stainless Steel front, top and sides
- Dependent glass doors (Full 180° opening)
- Energy saving high efficiency glass windows
- Heat keeping dual door seal system
- Coved, fastener-free, porcelain interior
- Stay cool heavy duty door handle
- Two speed, 1/2 hp, fan motor
- 11-position rack guides and 5 plated oven racks
- Solid state temperature controls
- Forced cool down fan mode
- Oven "heat" light cycles with burners
- Interior oven lights
- (1) year limited parts and labor warranty (reference <http://www.southbendnc.com/service.html> for limited warranty details)

Available Controls

SC-Standard Controls

140°F to 500°F solid state thermostat and 60 minute mechanical cook timer.

TC-Touchscreen Controls

150°F to 550°F temperature controller with 140°F to 200°F "Hold" thermostat. Digital display shows time and temperature. A fan cycle timer pulses the fan. Recipes can be created and used in oven group "Rack" mode to cook multiple items at once on different timers.

OPTIONS & ACCESSORIES AT ADDITIONAL COST

- Ventless Design *(UL certified)
- List the voltage, frequency, and amps (see utility information).
208 VAC, 1 Phase, 60 Hz.
- Stainless steel rear jacket
- Stainless steel exterior bottom
- Casters 4" or 6"
- Stainless steel dirt tray
- Swivel Caster - front with locks
- Down draft diverter for direct flue
- Export crating
- Marine edge top
- Stainless steel doors

STANDARD CONSTRUCTION SPECIFICATIONS

Exterior Finish: Stainless steel front, top and sides.

Doors: Dependent doors with windows. Low emission glass, stainless steel construction, heavy-duty welded steel frame and 5.8" diameter full-length hinge pin.

Oven Interior: Porcelain enamel finish, coved, fastener free.

Rack and Rack Guides: Heavy-duty removable wire rack guides spaced on 1-5/8" centers offer 11 different rack positions. 5 wire racks provided with each oven.

Blower Fan and Motor: 1/2hp, 2-speed motor, 1710/1120

Oven Heating: Oven heating is regulated by an adjustable solid state thermostat control. Blower fan circulates air within the cavity "scrubbing" heat to the oven interior for even heat distribution within the cavity. Manual reset high limit temperature control protects the oven from overheat condition.

Control Panel: Located on front, at right side of oven, away from heat zone. Slide out panel extends over 17" for easy servicing.

Interior Lights: Two 40 watt high temperature recessed lamps located within the oven cavity.

Legs: 6" stainless steel legs standard.

Electrical System: Terminal connections are located below oven section and are accessible from the front of the oven. These sheath type electrical heating elements located at the rear of the oven function as a single heating unit with a combined rating of 11 kW per deck. Available voltages include 208, 240, 380, and 480 VAC single or three phase, 50/60 Hz. Ovens equipped with 480VAC single or three phase heating elements use 240V controls and motors and do not require separate electrical lead wires.



Approval Notes: _____

Models: SLES/20SC SLES/20TC SLEB/20SC SLEB/20TC

SLE20

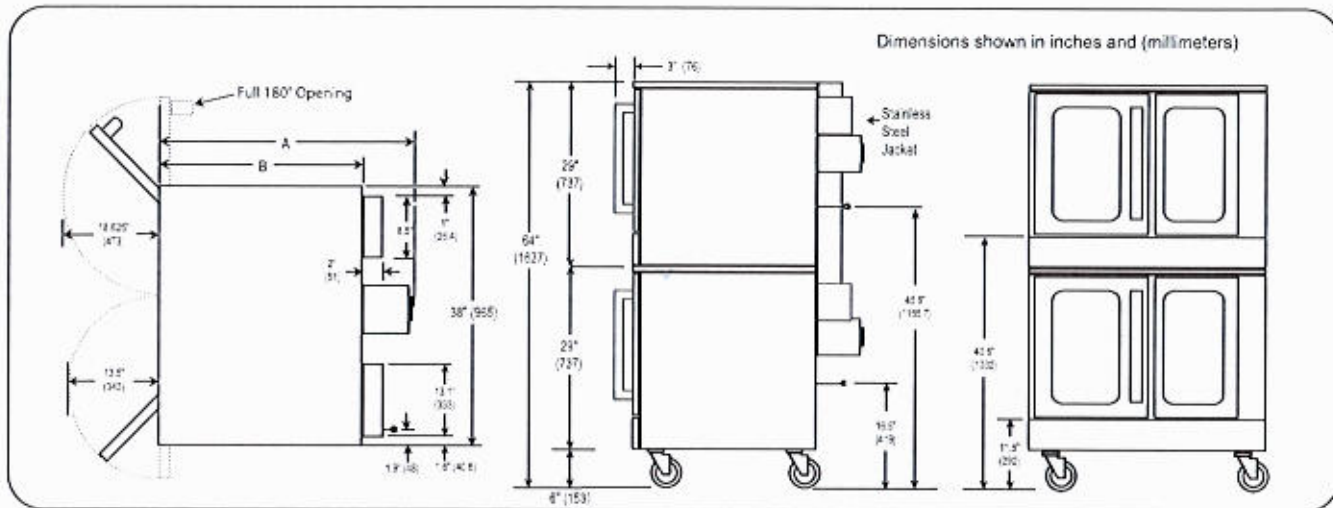

DIMENSIONS

MODEL	DEPTH		OVEN INTERIOR			RACK CLEARANCE		SHIPPING CRATE				
	A	B	WIDTH	DEPTH	HEIGHT	WIDTH	DEPTH	WIDTH	DEPTH	HEIGHT	VOLUME	WEIGHT
SLES/20	37.25" (946)	30.25" (768)	29" (737)	21.50" (546)	20" (508)	28.25" (718)	21" (533)	57.50" (1461)	45.5" (1156)	81.5" (2070)	123.4 cu. ft. (3.49 cu. m.)	1040 lbs (471.7 kg.)
SLEB/20	43.50" (1116)	36.50" (927)	29" (737)	29" (737)	20" (508)	28.25" (718)	27.25" (692)	57.50" (1397)	45.5" (1156)	81.5" (2070)	123.4 cu. ft. (3.49 cu. m.)	1180 lbs (535.2 kg.)

Dimensions shown in inches and (millimeters)

UTILITY INFORMATION

Standard: 1/2 horsepower, 2 speed motor, 1710/1120 r. p. m.

ELECTRICAL DATA	AMPS PER LINE						
	EACH OVEN	VOLTAGE	1 PHASE	3 PHASE			NEUT.
				X	Y	Z	
12 kW Heating Elements and Controls (11kW for Heating Elements, 1kW for Controls)	208 VAC, 60Hz	58	34	34	31	0	
	220/240 VAC, 50Hz	46	28	28	24	0	
	240 VAC, 60Hz	50	30	30	26	0	
	380/220 VAC, 50Hz	32	17	17	21	4	
	415/240 VAC, 50Hz	50	15	15	19	4	
	480 VAC, 60Hz	25	14	14	13	0	

* Electric units available for single or three phase operation and must be specified upon ordering.

MISCELLANEOUS

- Clearances from combustibles: Top, bottom, right, left side -0".
- Recommended - install under vented hood. Hood not required for ventless option.
- Check local codes for fire and sanitary regulations.

NOTICE:

Southbend has a policy of continuous product research and improvement. We reserve the right to change specifications and product design without notice. Such revisions do not entitle the buyer to corresponding changes, improvements, additions or replacements for previously purchased equipment.

**INTENDED FOR COMMERCIAL USE ONLY.
NOT FOR HOUSEHOLD USE.**

