

**PROJECT MANUAL
FOR
User Fee Road Construction-Plover Drive**

Bid No. 22-048



GEORGETOWN COUNTY, SOUTH CAROLINA

**VOLUME I
DIVISION 0 – BIDDING AND CONTRACT DOCUMENTS
DIVISION 1 – GENERAL REQUIREMENTS
&
VOLUME II
DIVISION 2 - SPECIAL PROVISIONS & SPECIFICATIONS**

**PREPARED BY:
GEORGETOWN COUNTY
DEPARTMENT OF PUBLIC SERVICES
PUBLIC WORKS DIVISION
AND
STANTEC**

December 8, 2022

VOLUME I - PROJECT MANUAL

December 8, 2022

TABLE OF CONTENTS

DIVISION 0- BIDDING AND CONTRACT DOCUMENTS

<u>Section No.</u>	<u>Title</u>	<u>Page</u>
00010	Request for Bids	4
00100	Instructions to Bidders.....	9
00200	<u>Optional Forms</u>	
	Intent to Respond	21
	Material Substitution Request	22
	Release and Indemnification Agreement for Electronic Media (CADD file requests)	24
00300	<u>Mandatory Forms</u>	
	Exhibit A Bid Form.....	25
	Exhibit B Acknowledgement of Addenda.....	31
	Exhibit C Non-Collusion Affidavit.....	32
	Exhibit D Indemnification.....	33
	Exhibit E List of Prime & Subcontractors.....	34
	Exhibit F Statement of Experience.....	35
	Exhibit G Unit Price Schedule.....	36
	Exhibit H Resident Certification for Preference.....	39
	Exhibit I Exceptions Page Form.....	41
00400	Bid Bond.....	42
00500	Sample Contract	44
00600	Performance Bond	50
00601	Labor and Material Payment Bond	52
00750	Summary Schedule and Key Milestones	54
00800	Special Project Conditions	55
00900	List of Drawings	57

DIVISION 1 - GENERAL REQUIREMENTS

<u>Section No.</u>	<u>Title</u>	<u>Page</u>
01100	Summary of Work	58
01290	Payment Procedures	60
01300	Regulatory Requirements	64
01310	Project Management and Coordination	66
01315	Progress Meetings.....	69
01320	Construction Progress and Documentation	71
01330	Submittal Procedures.....	77
01331	Schedule of Values	81
01400	Quality Requirements	83
01410	Testing Laboratory Services.....	85
01500	Temporary Facilities and Utilities.....	89
01510	Temporary Construction Controls	92

<u>Section No.</u>	<u>Title</u>	<u>Page</u>
01530	Barriers	95
01550	Access Roads and Parking Areas	97
01563	Handling of Incidental Fuel Spillage	99
01570	Traffic Regulation	101
01580	Project Identification and Permit Box	103
01600	Product Requirements.....	104
01610	Materials and Equipment.....	107
01620	Storage and Protection.....	113
01700	Execution Requirements.....	115
01710	Final Cleaning.....	118
01770	Closeout Procedures	120
01781	Project Record Documents	124
01790	Warranties and Bonds.....	127

VOL. II PROJECT MANUAL

DIVISION 2 – TECHNICAL SPECIFICATIONS

<u>Section No.</u>	<u>Title</u>	<u>Page</u>
C	Special Provisions.....	129
D	Georgetown County Water & Sewer District Details.....	147

END OF TABLE OF CONTENTS

[REMAINDER OF PAGE INTENTIONALLY LEFT BLANK]

**SECTION 00010
REQUEST FOR BIDS**

Time Line: Invitation for Bid #22-048

Item	Date	Time	Location*
Advertised Date of Issue:	Thursday, December 8, 2022	n/a	n/a
Pre-Bid Site Inspection:	INDEPENDENT (on own)	n/a	n/a
Inquiry Cut-Off Time:	Wednesday, December 21, 2022	3:30 PM ET	n/a
Bids Delivery Cut-Off Time:	Wednesday, January 4, 2023	3:30 PM ET	Electronic
*Bid Opening and Tabulation:	Wednesday, January 4, 2023	3:30 PM ET	Hybrid
County Council Consideration (Tentative)	Tuesday, January 24, 2023	5:30 PM ET	Council Chambers
Earliest Possible Notice to Proceed:	Monday, February 15, 2023	n/a	n/a
Final Completion:	240 Days from NTP	n/a	n/a

*Due to the current COVID-19 situation, County offices at the time of this bid posting remain open but access to the public may be limited to support social distancing efforts. At the time of this posting, bid openings may be performed virtually or by a hybrid method and may occur from an alternate secure and/or remote location as needed. A virtual meeting link will be posted under the bid number before the bid opening time so that members of the public may attend the meeting virtually. Vendors may also now attend the meeting in person at the Georgetown County Historic Courthouse, Purchasing Conference Room, 129 Screven St., Suite 239, 29440.

**Bid #22-048, User Fee Road Construction - Plover Drive
Georgetown County, South Carolina**

IMPORTANT COVID-19 NOTICE: Until further notice all bids MUST BE submitted electronically through the Purchasing Department's Vendor Registry webpage. Please click on the following link <http://www.georgetowncountysc.org/172/Purchasing> for instructions on how to submit bids electronically through this system. As always, emailed/faxed bids will not be accepted. Your bid must be submitted electronically through Georgetown County's Purchasing Vendor Registry page to ensure it remains sealed until the scheduled bid opening date and time.

Any scheduled bid openings will still be opened at the designated date and time as listed in the bid document or related addendum. However, at the time of this bid issuance these bid openings may be conducted virtually or by a hybrid method, both virtually and in person. As always, bid openings will be accompanied by at least one witness and bid tabulation results will be posted online for the public's viewing after the bid opening.

Purchasing Contact: **John Bullard**
 Phone (843)545-3076
 Fax: (843)545-3500
 E-mail: JBullard@GTCounty.org

The Georgetown County Department of Public Works is seeking competitive bids from South Carolina Department of Transportation approved contractors for User Fee Comprehensive Road Construction for Plover Drive in Georgetown, SC with a length of 0.25 miles. Work is scheduled to begin in February 2023. The improvements may also include installation of new drainage. The limits of work are described herein along with details that describe specific items of work.

SCOPE OF WORK:

BASE BID:

The Work Consists Of: re-grading, placing base course, and paving Plover Drive totaling approximately 0.25 miles. Quantities for this project are approximately 3,590 square yards of 8" Graded Aggregate Base Course, 983 cubic yards of Unclassified Excavation, 1,191 cubic yards of Borrow Excavation, Clearing and Grubbing within project limits, 350 Tons of Hot Mix Asphalt Surface Course Type C (200 lbs./square yard), 11 Tons of Hot Mix Asphalt Intermediate Course Type B (200 lbs./square yard), 26 Tons of Hot Mix Asphalt Base Course Type B (450 lbs./square yard), 456 linear feet of RC storm drainage pipe ranging in size from 15" to 24" RCP.

The work performed under this Contract shall include but may not be limited to: the furnishing of all labor, materials, equipment and services, whether specifically mentioned or not, that is required to complete the Construction of the Work of the project. All requirements of the State of South Carolina and all pertinent administrative regulations shall apply to this project as if herein written out in full.

Project Funding:

Funding for this project will be Georgetown County SC Road User Fees (local funds). This is a lump sum bid. Only the total bid price listed in Section 300, Exhibit A, Item #2 (second line in words) will be read at the bid opening. Exhibit G-Unit Price Schedule is to obtain a set unit pricing to be used for any change orders, if necessary, during the project.

Allowances:

A Utility Allowance is included in the contract for \$20,000 as reflected on the mandatory bid submittal form. See the last page of the Supplemental Specifications for further details.

Retainage, in the amount of ten percent (10%) of the value of construction costs incurred for the project, shall be withheld until the project has been completed to the satisfaction of Owner.

1) **Site Inspection:**

- a) The bidder is expected to have become familiar with and take into consideration, site conditions which may affect the work and to check all dimensions at the site.
- b) Each bidder shall acquaint themselves thoroughly as to the character and nature of the work to be done. Each bidder furthermore shall make a careful examination of the site of the work and inform themselves fully as to the difficulties to be encountered in performance of the work, the facilities for delivering, storing and placing materials and equipment and other conditions relating to construction and labor.
- c) The bidder shall examine the premises and the site and compare them with any applicable drawings and specifications. He/she shall familiarize themselves with the existing conditions such as obstructive area levels and any problems

related to erecting the required systems.

- d) No plea of ignorance of conditions that exist or may hereafter exist on the site of the work, or difficulties that may be encountered in the execution of the work, as a result of failure to make necessary investigations and examinations, will be accepted as an excuse for any failure or omission on the part of the Contractor to fulfill in every detail all the requirements of the contract documents and to complete the work for the consideration set forth therein, or as a basis for any claim whatsoever.
- e) Insofar as possible, the Contractor, in carrying out his/her work, must employ such methods or means as will not cause interruption of or interference with the work of any other Contractor, or County personnel at the site.
- f) When boring data is provided by the Owner, the Bidder shall assume responsibility for any conclusions he/she may draw from such data. (S)he may employ his/her own consultants to analyze available information and shall be responsible for any conclusions drawn from that information. The cost of such employment shall be borne solely by the Bidder.

2) Bid Security/Bid Bonding:

- a) Each bid must be accompanied by a Bid Bond, or by a certified check payable to Georgetown County, SC, for an amount equal to five per-cent (5%) of the total base bid as a guarantee that if the bid is accepted, the required Contract will be executed within fifteen (15) days after receipt of written notice of formal award of Contract. Bids not including such a bid bond will not be considered.
- b) The successful proposer must provide a Performance Bond from a surety company qualified to do business under the laws of the State of South Carolina in the amount of 100 percent (100%) of the contract amount, within fifteen (15) days the after receipt of written notice of formal award of the Contract.
- c) The successful offeror must provide a Payment and Material Bond from a surety company qualified to do business under the laws of the State of South Carolina in the amount of 100 percent (100%) of the contract amount, within fifteen (15) days after receipt of written notice of formal award of Contract.
- d) Should any Surety on the Construction Contract be determined unsatisfactory at any time by the Owner, notice will be given the Contractor who shall immediately provide a new Surety, satisfactory to the Owner and at no additional cost to the Owner. The Contract shall not be operative nor will any payments be due or paid until approval of the bonds has been made by the Owner.
- e) The Bidder shall require the Attorney-in-Fact who executes the required bonds, on behalf of the Surety, to affix thereto a certified and current copy of his Power of Attorney, indicating the monetary limit of such power.

- f) The cost of the bonds shall be included in the construction portion of the base bid.

3) Special Provisions and Conditions:

- a) Bidders shall be licensed as a General Contractor in the State of South Carolina and will hold all Trade Contracts on the project.
- b) Trade Contractors (Prime and Sub-Contractors) shall be qualified to perform work contracted for and shall be licensed as such in the State of South Carolina.
- c) The contractor will be responsible for disposal of any and all removed, unused and surplus materials and any fees and transportation costs associated with the disposal.
- d) The contractor is responsible for contacting the Palmetto Utility Protection Service (P.U.P.S.) at its 811 or toll-free number (1-888-721-7877) between the hours of 7:30 am (ET) and 5:30 pm (ET), Monday through Friday, 72 hours before starting the proposed work.

4) Permits:

The County has obtained and provided permits.

- 5) The Construction Contract will be awarded to the firm or team of firms submitting the lowest and most responsive and responsible proposal as determined by the County. Georgetown County reserves the right to reject any and all proposals for any reason at any time prior to execution of the Contract. It further reserves the right to waive any and all technicalities and formalities in the proposal process as well as accept in whole or in part such proposal or proposals where it deems it advisable in protection of the best interests of the County and to hold all proposals for examination for a period not to exceed ninety (90) calendar days. The selected Contractor is encouraged to utilize, to the extent possible, local firms and trades from within Georgetown County.

Throughout this Project Manual all references to the “Owner” shall mean the County of Georgetown, SC or its Designated Representative.

[THE REMAINDER OF THIS PAGE IS INTENTIONALLY LEFT BLANK.]

Plover Drive	
Length (Miles):	0.36
Segment Description:	Plover Drive off Pennyroyal Road

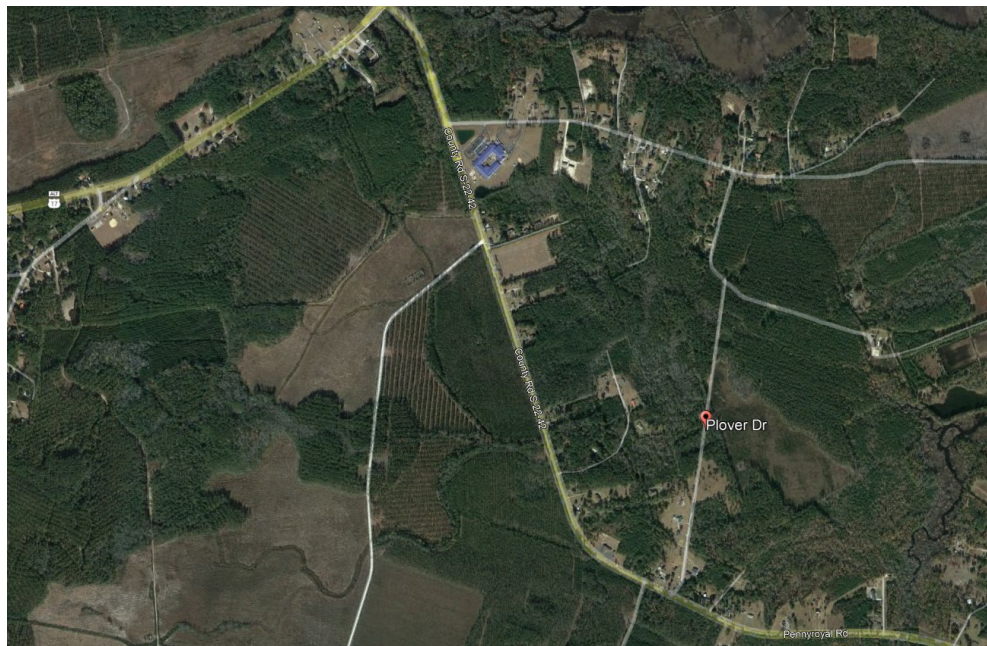
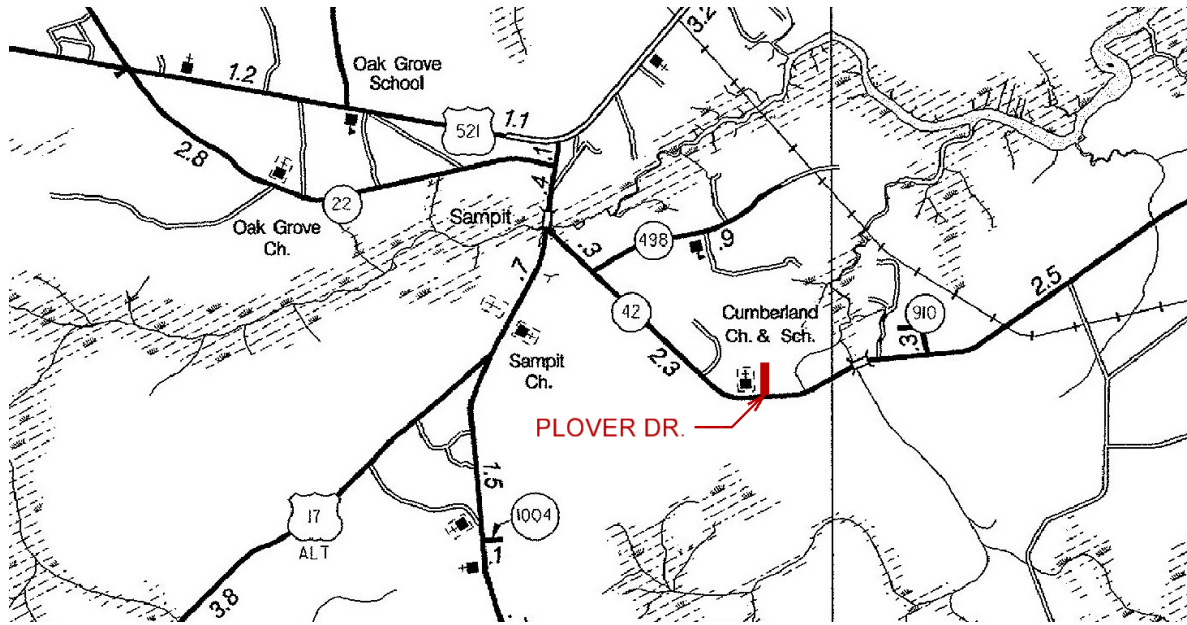

END OF SECTION 00010



SECTION 00100
INSTRUCTIONS TO BIDDERS
Bid #22-048

These are general instructions and conditions that accompany each bid package. If more specific instructions are given in the individual bid package, those instructions should prevail.

1. Submission of Questions

Questions must be submitted in writing via electronic mail, facsimile or postal mail to the Issuing Officer no later than the “Deadline for Questions” cutoff identified in the Bid Timeline on page four (4) in order to generate an official answer. All written questions will receive an official written response from the Georgetown County Purchasing Office (GCPO) and will become addenda to the solicitation.

GCPO reserves the right to reject or deny any requests made by the provider.

Impromptu, unwritten questions are permitted and verbal answers may be provided, but are only intended as general direction and will not represent the official GCPO position. The only official position of GCPO is that which is stated in writing and issued in the solicitation as addenda thereto.

No other means of communication, whether oral or written, shall be construed as a formal or official response/statement and may not be relied upon. **SEND QUESTIONS TO:**

John Bullard, Senior Buyer
Post Office Box 421270, Georgetown, SC 29442-4200
Fax: (843) 545-3500
Email: JBullard@GTCounty.org

2. Electronic sealed bids for to provide USER FEE ROAD CONSTRUCTION - PLOVER DRIVE shall be received via the County’s Vendor Registry webpage until the cut-off time shown in the bid timeline on page four (4) of this document. Bids will then be promptly opened at the designated time by the Buyer. Bids that are not received prior to the stated opening date and time will be considered **NON RESPONSIVE**. An official authorized to bind the offer must sign all proposals submitted.

3. Inclement Weather/Closure of County Courthouse

Due to the current COVID-19 situation, County offices at the time of this bid posting remain open but may be limited to the public. Bid openings at the time of this issuance are being conducted virtually or hybrid and may occur from an alternate secure and/or remote location as needed.

4. This solicitation does not commit Georgetown County to award a contract, to pay any cost incurred in the preparation of the bid, or to procure or contract for goods or services. It is the responsibility of each bidder to see that the Georgetown County Purchasing Office receives bids on, or before, the date and time specified for the bid opening. No bid will be accepted thereafter. The County assumes no responsibility for delivery of bids that are mailed. Georgetown County reserves the right to reject any or all bids and to waive any informalities and technicalities in the bid process.

5. NON EXCLUSIVITY

Nothing herein is intended nor shall be construed as creating any exclusive arrangement with Contractor. Any resulting contract shall not restrict the County from acquiring similar, equal or like goods and/or services from other entities or sources, when Staff determines internally that this resulting action is in the best interest of Georgetown County.

6. No Bidder may submit more than one bid. Multiple bids for different manufacturers but represented by the same firm will not be accepted. Bids offered directly from manufacturers shall indicate if a local dealer/representative will be involved.

7. Definitions:

a) The terms “Proposer”, “Offeror”, “Vendor” or “Bidder” refer to those parties who are submitting sealed responses for the work set forth in this document to the OWNER, as distinct from a sub-bidder who provides a bid to the Bidder. The term “Contractor” refers to the successful Bidder.

b) The term “USER FEE ROAD CONSTRUCTION - PLOVER DRIVE” or “the Work” or “Project” refers to the complete set of services as specified in this document, in every aspect.

c) The terms “Owner” and “County” refer to the County of Georgetown, South Carolina.

d) Where the words “shall” or “must” are used, it signifies an absolute minimum function or capacity that, if not satisfied, may result in disqualification.

e) Where the words “should”, “may”, or “is desirable” are used, it signifies desirable, but not mandatory functions or capacities. Bidders who are able to provide these functions or capacities may be evaluated more favorably than those who cannot.

8. Bidders must be licensed as a General Contractor in the State of South Carolina and will hold all Trade Contracts and the Building Permit on the Project.

7. Trade Contractors (Prime and sub-contractors) shall be qualified to perform the work contracted for and shall be licensed as such in the State of South Carolina.

8. Design services shall be performed by qualified architects and engineers licensed to perform the contracted work in the State of South Carolina.

9. Correction or Withdrawal of Bids; Cancellation of Awards

An offeror must submit in writing a request to either correct or withdraw a bid to the Procurement Officer. Each written request must document the fact that the offeror’s mistake is clearly an error that will cause him substantial loss.

a) Correction of awards : An offeror shall not be permitted to correct a bid mistake after bid opening that would cause such offeror to have the low bid unless the mistake in the judgment of the Procurement Officer is clearly evident from examining the bid document; for example, extension of unit prices or errors in addition.

b) Cancellation of awards prior to performance: When it is determined after an award

has been issued but before performance has begun that Georgetown County's requirements for the goods or services have changed or have not been met, the award or contract may be canceled and either re-awarded or a new solicitation issued.

10. **Faxed or E-mailed bids will not be accepted by Georgetown County. Electronic bid submissions must be submitted through the Georgetown County Purchasing Vendor Registry page to ensure they remain sealed until the scheduled bid opening date and time.**
11. If you need any reasonable accommodation for any type of disability in order to participate in this procurement, please contact the purchasing office as soon as possible.
12. Title VI of the Civil Rights Act of 1964: Georgetown County hereby gives public notice that it is the policy of the agency to assure full compliance with Title VI of the Civil Rights Act of 1964, the Civil Rights Restoration Act of 1987, Executive Order 12898 on Environmental Justice, and related statutes and regulations in all programs and activities. Title VI requires that no person in the United States of America shall, on the grounds of race, color, or national origin, be excluded from the participation in, be denied the benefits of, or be otherwise subjected to discrimination under any program or activity for which Georgetown County receives federal financial assistance.
13. Any deviations from the specifications or modification of this bid and any extra or incidental work or reductions in work shall be set forth in writing and signed by both parties prior to making such change. Any increase or decrease in the bid price resulting from such change shall be included in writing.
14. Exceptions: The bidder shall list on a separate sheet of paper any variations from, or exceptions to, the conditions and specifications of this bid. This sheet shall be labeled "Exception(s) to Bid Conditions and Specifications," and shall be attached to the bid. When Proposers find instances where they must take exception with certain requirements or specifications of the bid, all exceptions shall be clearly identified. Written explanations shall include the scope of the exceptions, the ramifications of the exceptions for the County of Georgetown, and a description of the advantage to be gained or disadvantages to be incurred by the County as a result of these exceptions. If none, write "NONE".
15. Georgetown County reserves the right to reject any or all bids, and to waive as an informality any irregularities contained in any bid as may be deemed in the best interest of the County. Georgetown County further reserves the right to reject any bid submitted, at its sole option, that the vendor may not be able to meet the service requirements of the bid.
16. Publicity releases: contractor agrees not to refer to award of any resulting contract in commercial advertising in such a manner as to state or imply that the products or services provided are endorsed or preferred by the user.
17. Material Safety Data Sheets: The County of Georgetown will not receive any materials, products, or chemicals which may be hazardous to an employee's health unless accompanied by a Material Data Sheet when received.
18. Ownership of Copyright: All right, title and interest in all copyrightable materials which vendor shall create in the performance of its obligations hereunder shall be the property of the procurer.

Vendor agrees to assign and hereby does assign any and all interest it has in and to such material to procurer. Vendor agrees, upon the request of procurer to execute all papers and perform all other such acts necessary to assist procurer to obtain and register copyrights on such materials. Where applicable, works of authorship created by the vendor in the performance of its obligations hereunder, shall be considered “works for hire” as defined in the U.S. Copyright Act.

19. Ownership of Documents: Any reports, studies, photographs, negatives or other documents prepared by vendor in the performance of its obligations shall be the exclusive property of the procurer and all such material shall be remitted to the procurer by the vendor upon completion, termination or cancellation of this order. Vendor shall not use, willingly allow or cause to have such material used for any purpose other than performance of its obligations under this order without the prior written consent of the procurer.
20. Affirmative Action: The contractor will take affirmative action in complying with all Federal and State requirements concerning fair employment and employment of the handicapped, and concerning the treatment of all employees, without regard or discrimination by reason of age, race, color, religion, sex, national origin or physical handicap. The following are incorporated herein by reference: 41 C.F.R. 60-1.4, 60-250.4 and 60-741.4.
21. Inclusion and participation of disadvantaged, small, and local business entities is strongly encouraged, but minimum participation standards are not in effect for this project.
22. All Federally Funded or Assisted Construction Contracts Over \$2,000:
 - A. Davis-Bacon Requirements. These contracts need to include a provision for compliance with the Davis-Bacon Act (40 USC 276a to a—7) and the Department of Labor implementing regulations (29 CFR Part 5). Under this Act, Contractors are required to include the contract provisions in Section 5.5 (a) of 29 CFR Part 5, and to pay wages to laborers and mechanics at a rate not less than the minimum wages specified in the wage determination made by the Secretary of Labor. In addition, Contractors shall be required to pay wages not less than the minimum wages specified in the wage determination made by the Secretary of Labor. In addition, Contractors shall be required to pay wages not less often than once a week. Current Wage Determination for Georgetown County in South Carolina is available on-line at: <https://sam.gov/content/wage-determinations>
 - B. Contract Work Hours and Safety Standard Act Requirements. The contracts must include a provision for compliance with Sections 103 and 107 of the Contract Work Hours and Safety Standards Act (40 USC 327-330) as supplemented by the Department of Labor regulations (29 CFR Part 5). Under Section 103 of the Act, each Contractor shall be required to compute the wages of every mechanic and laborer on the basis of a standard workweek of 40 hours. Work in excess of the standard workweek is permissible provided that the worker is compensated at a rate not less than one times the basic rate of pay for all hours worked in excess of 40 hours in the workweek. Section 107 of the Act is applicable to construction work and provides that no laborer or mechanic shall be required to work in surroundings or under working conditions which are unsanitary, hazardous, or dangerous to health and safety as determined under construction, safety and health standards promulgated by the Secretary of Labor. These requirements do not apply to the purchases of supplies, materials, or articles ordinarily available on the open market, or contracts for transportation or transmission of intelligence.

C. Copeland "Anti-Kickback" Act Requirements. All construction contracts over \$2,000.00 must include a provision for compliance with the Copeland "Anti-Kickback" Act (18 U.S.C. 874) as supplemented in Department of Labor regulations (29 CFR Part 3). This act provides that each Contractor shall be prohibited from inducing, by any means, persons employed in the construction, completion, or repaid of public work to give up any part of their compensation.

23. CERTIFICATION REGARDING DRUG-FREE WORKPLACE:

The contractor certifies that the vendor(s) will provide a "drug-free workplace" as that term is defined in Section 44-107-30 of the Code of Laws of South Carolina, 1976, as amended, by the complying with the requirements set forth in title 44, Chapter 107.

24. Certification of Non-Segregated Facilities

The federally-assisted construction contractor certifies that he does not maintain or provide, for his employees, any segregated facilities at any of his establishments and that he does not permit his employees to perform their services at any location, under his control, where segregated facilities are maintained. The federally-assisted construction contractor certifies that he will not maintain or provide, for his employees, segregated facilities at any of his establishments and that he will not permit his employees to perform their services at any location under his control where segregated facilities are maintained. The federally-assisted construction contractor agrees that a breach of this certification is a violation of the Equal Opportunity Clause in this Contract.

As used in this certification, the term "segregated facilities" means any waiting rooms, work areas, restrooms, and washrooms, restaurants and other eating areas, time clocks, locker rooms and other storage or dressing areas, parking lots, drinking fountains, recreation or entertainment areas, transportation, and housing facilities provided for employees which are segregated on the basis of race, color, religion, or national origin because of habit, local custom, or any other reason. The federally assisted construction contractor agrees that (except where he has obtained identical certifications from proposed subcontractors for specific time periods) he will obtain identical certifications from proposed subcontractors prior to the award of subcontracts exceeding \$10,000 which are not exempt from the provisions of the Equal Opportunity Clause and that he will retain such certifications in his files.

25. Bidders must clearly mark as "confidential" each part of their bid which they consider to be proprietary information that could be exempt from disclosure under section 30-4-40, Code of Laws of South Carolina 1976, as amended (Freedom of Information Act). If any part is designated as confidential, there must be attached to that part an explanation of how this information fits within one or more categories listed in section 30-4-40. The County reserves the right to determine whether this information should be exempt from disclosure and no legal action may be brought against the County or its agents for its determination in this regard.

26. Nothing herein is intended to exclude any responsible vendor, his product or service or in any way restrain or restrict competition. On the contrary, all responsible vendors are encouraged to bid and their bids are solicited.

27. Acknowledgement of Addenda

Each contractor is responsible to verify the number of total addenda issued prior to bid. **Failure to acknowledge all addenda may disqualify the bidder.** All addenda are posted by the County at

the website located at www.georgetowncountysc.org, select “Purchasing” and “Current Bids”. It is each proposer’s responsibility to verify that all addenda have been received and acknowledged.

28. This Invitation for Bid covers the estimated requirements to provide USER FEE ROAD CONSTRUCTION - PLOVER DRIVE for the Georgetown County Department of Public Services, Public Works Division. The purpose is to establish a Construction Contract with firm pricing and project schedule.

29. Bids must be made on Proposal or Bid Form furnished or will be rejected. Proposals shall be typewritten or written in ink on the form prepared by the County. The person signing the bid shall initial all corrections or erasures.

30. Insurance

The successful bidder shall procure, maintain, and provide proof of, insurance coverage for injuries to persons and/or property damage as may arise from or in conjunction with, the work performed on behalf of the County by the bidder, his agents, representatives, employees or subcontractors. Proof of coverage as contained herein shall be submitted fifteen (15) days prior to the commencement of work and such coverage shall be maintained by the bidder for the duration of the contract period; for occurrence policies.

a. General Liability

Coverage shall be as broad as: Comprehensive General Liability endorsed to include Broad Form, Commercial General Liability form including Products/Completed Operations.

1. Minimum Limits

General Liability:

\$1,000,000 General Aggregate Limit

\$1,000,000 Products & Completed Operations

\$1,000,000 Personal and Advertising Injury

\$1,000,000 Each Occurrence Limit

\$50,000 Fire Damage Limit

\$5,000 Medical Expense Limit

b. Automobile Liability

Coverage sufficient to cover all vehicles owned, used, or hired by the bidder, his agents, representatives, employees or subcontractors.

1. Minimum Limits

Automobile Liability:

\$1,000,000 Combined Single Limit

\$1,000,000 Each Occurrence Limit

\$5,000 Medical Expense Limit

c. Workers' Compensation

Limits as required by the Workers' Compensation Act of SC. Employers Liability, \$1,000,000.

d. Owners' & Contractors' Protective Liability

Policy will be in name of County. Minimum limits required are \$1,000,000.

e. Professional Liability (a/k/a Errors and Omissions)

N/A.

f. Coverage Provisions

1. All deductibles or self-insured retention shall appear on the certificate(s).
2. The County of Georgetown, its officers/ officials, employees, agents and volunteers shall be added as "additional insured" as their interests may appear. This provision does not apply to Professional Liability or Workers' Compensation/Employers' Liability.
3. The offeror's insurance shall be primary over any applicable insurance or self-insurance maintained by the County.
4. Shall provide 30 days written notice to the County before any cancellation, suspension, or void of coverage in whole or part, where such provision is reasonable.
5. All coverage for subcontractors of the bidder shall be subject to all of the requirements stated herein.
6. All deductibles or self-insured retention shall appear on the certificate(s) and shall be subject to approval by the County. At the option of the County, either; the insurer shall reduce or eliminate such deductible or self-insured retention; or the bidder shall be required to procure a bond guaranteeing payment of losses and related claims expenses.
7. Failure to comply with any reporting provisions of the policy(s) shall not affect coverage provided the County, its officers/officials, agents, employees and volunteers.
8. The insurer shall agree to waive all rights of subrogation against the County, its officers/officials, agents, employees or volunteers for any act, omission or condition of premises which the parties may be held liable by reason of negligence.
9. The bidder shall furnish the County certificates of insurance including endorsements affecting coverage. The certificates are to be signed by a person authorized by the insurance company(s) to bind coverage on its' behalf, if executed by a broker, notarized copy of authorization to bind, or certify coverage must be attached.
10. All insurance shall be placed with insurers maintaining an A.M. Best rating of no less than an A:VII. If A.M. Best rating is less than A:VII, approval must be received from County's Risk Officer.

31. Workman's Compensation Coverage

Georgetown County, SC will require each contractor and service provider to maintain on file with the purchasing officer, a current Certificate of Insurance showing limits as required by the Workers' Compensation Act of SC: Employers Liability, \$1,000,000.

The law also recognizes "statutory employees." These are employees who work for a subcontractor who may be working for a business or another contractor. Employers should inquire whether or not a subcontractor working for them has workers' compensation insurance,

regardless of the number of employees employed by the subcontractor. If the subcontractor does not, the subcontractor's injured employees would be covered under the employer's workers' compensation insurance. If the subcontractor does not carry workers' compensation insurance, then the owner or the principal contractor would be liable just as if the subcontractor's employee was one of their employees.

For answers to additional questions, visit the SC Worker's Compensation Commission website, at: <https://wcc.sc.gov/frequently-asked-questions>

32. Hold Harmless Clause

The Contractor shall, during the term of the contract including any warranty period, indemnify, defend, and hold harmless the County, its officials, employees, agents, and representatives thereof from all suits, actions, or claims of any kind, including attorney's fees, brought on account of any personal injuries, damages, or violations of rights, sustained by any person or property in consequence of any neglect in safeguarding contract work or on account of any act or omission by the contractor or his employees, or from any claims or amounts arising from violation of any law, bylaw, ordinance, regulation or decree. The vendor agrees that this clause shall include claims involving infringement of patent or copyright.

33. Condition of Items

All items shall be new, in first class condition, including containers suitable for shipment and storage, unless otherwise indicated herein. Verbal agreements to the contrary will not be recognized.

34. Workmanship and Inspection

All work under this contract shall be performed in a skillful and workmanlike manner. The County may, in writing, require the Contractor to remove any employee from work that the County deems incompetent or careless.

Further, the County may, from time to time, make inspections of the work performed under this contract. Any inspection by the County does not relieve the Contractor from any responsibility regarding defects or other failures to meet the contract requirements.

35. Progress Payments (If Applicable)

Contractor's Application for Payment shall be submitted to the Owner on AIA Document G702 and G703--1992 Edition, or such other form as may be mutually agreed upon. The period covered by each Application for Payment shall be not less than one calendar month. The Owner shall make progress payments to the Contractor on undisputed amounts certified by the Architect within thirty (30) days from receipt of the Application for Payment by the Owner.

36. South Carolina Sales Tax

The County of Georgetown, SC is not exempt and pays the appropriate SC sales tax on all applicable purchases.

37. Assignment of Contract

This contract may not be assigned in whole or part without the written consent of the Purchasing Officer.

38. Termination

Subject to the provisions below, the contract may be terminated by the County upon sixty (60) days advance written notice to the other party; but if any work or service hereunder is in progress, but not completed as of the date of termination, then this contract may be extended upon written approval of the County until said work or services are completed and accepted.

- a. Termination for Convenience
In the event that this contract is terminated or canceled upon request and for the convenience of the County, without the required sixty (60) days advance written notice, then the County shall negotiate reasonable termination costs, if applicable.
- b. Termination for Cause
Termination by the County for cause, default or negligence on the part of the contractor shall be excluded from the foregoing provision; termination costs, if any, shall not apply. The sixty (60) days advance notice requirement is waived in the event of Termination for Cause.
- c. Non-Appropriation:
It is understood and agreed by the parties that in the event funds are not appropriated in the current fiscal year or any subsequent fiscal years, this contract will become null and void and the County will only be required to pay for services completed to the satisfaction of the County.

39. Default

In case of default by the contractor, for any reason whatsoever, the County may procure the goods or services from another source and hold the contractor responsible for any resulting excess cost and may seek other remedies under law.

40. Severability

In the event that any provision shall be adjudged or decreed to be invalid, such ruling shall not invalidate the entire Agreement but shall pertain only to the provision in question and the remaining provisions shall continue to be valid, binding and in full force and effect.

41. Applicable Laws

This Agreement shall be governed by and construed in accordance with the laws of the State of South Carolina, U.S.A.

42. Claims and Disputes:

All claims, disputes and other matters in question between parties arising out of, or relating to, this Agreement, or the breach thereof, shall be decided in the Circuit Court of the Fifteenth Judicial circuit in Georgetown County, South Carolina. By executing this Agreement, all parties specifically consent to venue and jurisdiction in Georgetown County, South Carolina and waive any right to contest jurisdiction and venue in said Court.

43. Rights of County

The County reserves the right to reject all or any part of any bid, waive informalities and award the contract to the lowest responsive and responsible bidder to best serve the interest of the County.

44. Award of Bid

In determining the lowest responsive and responsible bidder, in addition to price, there shall be considered the following:

- (a) The ability, capacity and skill of the bidder to perform the contract.
- (b) Whether the bidder can perform the contract within the time specified, without delay of interference.
- (c) The character, integrity, reputation, judgment, experience and efficiency of the bidder.
- (d) The quality of performance on previous contracts.
- (e) The previous and existing compliance by the bidder with laws and ordinances relating to the contract.

45. Notice of Award

A *Notice of Intent to Award* will be mailed to all respondents.

46. Protest

Bidders may refer to Sections 2-67, 2-73, and 2-74 of Ordinance #20-32, also known as the Georgetown County, South Carolina Purchasing Policy to determine their remedies concerning this competitive process. The failure to be awarded a bid shall not be valid grounds for protest.

47. Debarment

By submitting a bid, the offeror certifies to the best of its knowledge and belief, that it and its principals, sub-contractors and assigns are not presently debarred, suspended, proposed for debarment, declared ineligible, or voluntarily excluded from covered transactions by any Federal, State or local department or agency. A copy of the County's debarment procedure in accordance with Section 2-68 of Ordinance #20-32, also known as the Georgetown County, South Carolina Purchasing Policy is available upon request.

48. Firm Pricing for County Acceptance

Bid price must be firm for County acceptance for 90 days from bid opening date.

49. Mobilization After Notice to Proceed

Bid must show the number of days required to mobilize after receiving a Notice to Proceed under normal conditions. Failure to state delivery time obligates bidder to complete delivery in fourteen (14) calendar days. Unrealistically short or long delivery promised may cause bid to be disregarded. Consistent failure to meet delivery promises without valid reason may be cause for removal from bid list.

50. BRAND NAME OR EQUAL:

a) The use of a "Brand Name Only" specification is for the purpose of describing the sole item that will satisfy the county's requirements. Bids offering alternate products will be declared non-responsive.

b) The use of a "Brand Name Or Equal" specification is for the purpose of describing the standard of quality, performance and characteristics desired and is not intended to limit or restrict competition. An item shall be considered to be substantially equivalent, or "equal" to the specified brand in the opinion of the Chief Procurement Officer, the County can reasonably anticipate sufficiently similar quality, capacity, durability, performance, utility and productivity as provided by the specified brand.

c) The use of a "Brand Name Or Pre-Approved Equal" specification with a reference to a brand name or model number does not preclude an offer of a comparable or better product, if full specifications and descriptive literature are provided for the product. Bidder shall submit a Material Substitution Request form for a proposed equal to Purchasing by the date and time listed in the bid solicitation to allow Owner to make a determination of equality to the brand specified. If Owner approves the proposed equal, an addendum to the bid will be issued specifically identifying the item as a pre-approved equivalent. Failure to provide such specifications and descriptive literature may be cause for rejection of the offer.

51. Environmental Management:

Vendor/Supplier/Contractor will be responsible for complying with all federal, state and local environmental regulations relating to transportation, handling, storage, spillage and any other aspect of providing the services specified herein, as applicable.

52. Bid Tabulation Results

Vendors wishing to view the bid tabulation results may visit the Georgetown County, SC web-site at: <http://www.georgetowncountysc.org>. Select “Bid Opportunities” from the Quick Links box, then “Bids Under Review” and double click the link under the individual bid listing.

53. The Bidder hereby certifies that he or she has carefully examined all of the Documents for the project, has carefully and thoroughly reviewed this Request for Bid/Quotation, has inspected the location of the project (if applicable), and understands the nature and scope of the work to be done; and that this Bid is based upon the terms, specifications, requirements, and conditions of the Request for Bid/ Documents. The Bidder further agrees that the performance time specified is a reasonable time, having carefully considered the nature and scope of the project as aforesaid.

54. Apparent omission of a detailed description concerning any point, shall be regarded as meaning the best commercial practice is to prevail and that only material and workmanship of the finest quality are to be used.

55. Response Clarification

Georgetown County reserves the right to request additional written or oral information from Bidders in order to obtain clarification of their Responses.

56. Any attempt by the vendor to influence the opinion of County Staff or County Council by discussion, promotion, advertising, misrepresentation of the submittal or purchasing process or any procedure to promote their offer will constitute a violation of the vendor submittal conditions and will cause the vendor’s submittal to be declared null and void.

57. Georgetown County, SC has a Local Vendor Preference Option by ordinance. See the RESIDENCE CERTIFICATION FOR LOCAL PREFERENCE form attached for details.

58. Substitutions and Product Options

Written requests for changes in products, materials, equipment and methods of construction required by the Contract Documents shall be submitted to the Owner prior to bidding in accordance with the timeline provided and using the Material Substitution Request form provided and in accordance with *The Project Manual, Division 1, Section 01600*.

59. Bidding Documents

a) Each Bidder shall carefully examine the Bidding and Contract Documents, General Requirements, Drawings and Technical Specifications and all addenda or other revisions and thoroughly familiarize themselves with the detailed requirements prior to submitting a Bid. Bidders shall promptly notify the Owner in writing of any ambiguity, inconsistency, error or omission, which they may discover upon examination of the Bidding and Contract Documents, Project Site and / or local conditions. The Owner shall make such interpretations, corrections or changes to the Bidding Documents and will reply to all questions submitted by the Bidders. The Owner will log all responses and issue an addendum as may be appropriate. The Owner will not be responsible for any oral instructions and / or responses. Interpretations, corrections or changes made in any other manner will not be binding. All addenda sent to Bidders will become a part of the Bidding and Contract Documents. All inquiries shall be directed in

writing or transmitted by facsimile to the office of the Owner. No allowance will be made after Bids are received due to oversight and / or error by bidder.

- b) Each Bidder shall carefully review the Table of Contents and the List of Drawings in the Project Manual to determine if any instrument is missing from the Bidding Documents. Bidders shall promptly notify the Owner, in writing, of any discrepancy.
- c) Addenda will not be mailed or faxed to all Bidders. Copies of Addenda will be made available through the County website. Prior to submitting a Bid each Bidder shall ascertain that he/she has received all Addenda issued.
- d) Owner does not assume any responsibility for errors, omissions or misinterpretations resulting from the Bidder's use of incomplete Bidding Documents.

60. Retainage

Retainage in the amount of ten percent (10%) of the value of construction costs incurred for the project, shall be withheld until the project has been completed to the satisfaction of Owner.

61. Liquidated Damages

Refer to *The Project Manual, Vol. 1, Division 1, Section 01100, Summary of Work.*

62. Allowances

A Utility Allowance is included in the contract for each roadway. See the last page of the Supplemental Specifications for details.

63. The contractor will be responsible for disposal of any and all removed, unused and surplus materials and any fees and transportation costs associated with the disposal.

64. The contractor is responsible for contacting the **Palmetto Utility Protection Service (P.U.P.S.)** at its **811** or toll-free number **(1-888-721-7877)** between the hours of 7:30 am (ET) and 5:30 pm (ET), Monday through Friday, 72 hours before starting the proposed work.

END OF SECTION 00100

[THE REMAINDER OF THIS PAGE IS INTENTIONALLY LEFT BLANK.]



SECTION 00200

Intent to Respond

REF: **Bid #22-048, USER FEE ROAD CONSTRUCTION – PLOVER DRIVE**

If your company intends to respond to this solicitation, please complete and promptly return this form to assure that you can be included on the mailing list to receive all addenda regarding this project.

It is not necessary to return any other portion of the bid documents if you are not bidding.

Failure to return the Intent to Respond shall not be sufficient cause to rule a submittal as non-responsive; nor does the return of the form obligate an interested party to submit a response. Georgetown County's efforts to directly provide interested parties with addenda or additional information are provided as a courtesy only, and do not alleviate the respondent from their obligation to verify they have received and considered all addenda. All addenda are published and available on the county website at <http://www.gtcounty.org/> select "Bid Opportunities" from the Quick Links at the bottom of the County's main webpage.

Our firm **does** intend on responding to this solicitation.

Our firm **does not** intend on responding to this solicitation.

Company Name: _____

Address: _____

Contact Person: _____

Telephone: _____

Fax: _____

E-Mail: _____

How did you hear about this opportunity? _____

Reason if **not** responding: _____

Please return this completed form to John Bullard, Senior Buyer:

- by e-mail to JBullard@GTCounty.org
- or by Fax to (843) 545-3500.

[End of Intent to Respond]



MATERIAL SUBSTITUTION REQUEST

Bid #22-048, USER FEE ROAD CONSTRUCTION - PLOVER DRIVE

Date: _____

We hereby submit for your review the following PRODUCT SUBSTITUTION of the specified material for the above listed project.

Section: _____

Paragraph: _____

Specified Material: _____

Attached is complete technical data of the PRODUCT SUBSTITUTION, highlighted or underlined for easy reading, including laboratory test, as necessary, in duplicate. Included is complete information on changes to the Project Manual Documents required by the proposed PRODUCT SUBSTITUTION for its proper installation.

A) The Trade Contractor, under whose transmittal this information is sent, has reviewed the PRODUCT SUBSTITUTION and agrees it is applicable to this project in the location described and agrees to warrant/guarantee the use of the PRODUCT SUBSTITUTION in the same manner he would the Specified Product.

Yes No

If not, explain: _____

B) Does the PRODUCT SUBSTITUTION affect the dimensions shown on the Drawings in ANY WAY?

Yes No

If so, how? _____

C) Does the undersigned have the approval of the Manufacturer/Supplier to pay for any changes to the building design, including engineering and detailing costs, caused by the requested PRODUCT SUBSTITUTION?

Yes No

If so, to what extent? _____

D) What effect does the PRODUCT SUBSTITUTION acceptance have on other trades?

None Don't Know As follows:

E) Difference between proposed PRODUCT SUBSTITUTION and the Specified Product? BE SPECIFIC IN DESCRIPTION. (ASTM No., Size, Gauge, Material, Color Availability, Construction)

(Attach additional pages as required)

F) Manufacturer's guarantees and warranties of the PRODUCT SUBSTITUTION and the Specified Product?

Same Different (Explain)

G) What is the cost differential of the PRODUCT SUBSTITUTION in comparison to the Specified Product?

Same Less Expensive by \$ _____ More Expensive by \$ _____

I) The PRODUCT SUBSTITUTION has been verified by the undersigned with the Manufacturer/Supplier as meeting or exceeding the specifications of the Specified item.

Yes No Waiting for answer.

THE UNDERSIGNED Trade Contractor states that the function, appearance, and quality of the PRODUCT SUBSTITUTION are equivalent or superior to the specified item. In addition, I, as the Trade Contractor will assume all responsibility for any impact or delay the review and evaluation of the alternate product may cause. Your approval of the Substitute Product in no way will relieve me as the Trade Contractor of my responsibilities to conform with all requirements of the Contract Documents.

Submitted By: _____
Signature Printed

FOR USE BY ARCHITECT/ENGINEER:

RECEIVED TOO LATE NOT ACCEPTED APPROVED AS NOTED

FOR BIDDING ONLY, FINAL APPROVAL SUBJECT TO SUBMITTAL DATA IN ACCORDANCE WITH REQUIREMENTS OF CONTRACT DOCUMENTS.

DATE: _____

PRINTED NAME: _____

SIGNATURE: _____

**RELEASE AND INDEMNIFICATION AGREEMENT
FOR ELECTRONIC MEDIA (CADD File Requests)**

THIS AGREEMENT is entered into among STANTEC, Inc. as “Consultant” and _____ as “Client”.

Consultant has been requested to provide ELECTRONIC MEDIA related to the Project known as:
USER FEE ROAD CONSTRUCTION-PLOVER DRIVE.

The delivery of this information in electronic format is for the benefit of the Client for whom the services have been performed. This delivery constitutes a nonexclusive, limited license for the recipient to use the information in the electronic file for the specific purpose of responding to the requirements of the Client on this Project. Nothing in this transfer should be construed to create any right of the user to rely on the information provided or that the use of this electronic information implies the review and approval by the Consultant. Any use of this information is at the sole risk and liability of the user who retains the responsibility for updating the information to reflect any changes following the preparation date of this information.

Consultant makes no performance guarantees, express or implied warranties, and assumes no obligation or liability for the reliability or accuracy of the information contained herein; or for the accuracy of the information translated by Consultant’s software for use with the end users’ software. Moreover, any reuse of electronically stored documents imports a significant risk of error and misinterpretation through corruption of data, incompatibilities of computer programs, intentional manipulation, and the like. Consultant makes no representations as to long term compatibility, usability, or readability of documents resulting from use of software application packages, operating systems, or computer hardware differing from those used by Consultant. Consultant assumes no liability for the hardware or software damage that may result from the use of the electronic files provided on disk, or by electronic transfer due to unknown viruses that may reside on the electronic media when transferred to the end user.

The information contained in the signed and sealed documents should be deemed to be correct and superior to this electronic information. If there is a discrepancy between the electronic files and the hard copies, the hard copies govern.

NOW, THEREFORE, in consideration of the voluntary release of the electronically stored documents for this Project and contingent upon receipt of those documents, Client and, if applicable, Other party(s), jointly and severally, hereby release and hold harmless the Consultant, its principals, agents, and employees, from any and all liability or responsibility to any person or entity arising out of any use of the electronic documents or any data derived there from.

For Client _____:

For Stantec Inc.:

Signature

Signature

Printed name & title

Printed name & title

Date _____

Date _____



SECTION 00300
“EXHIBIT A” - BID FORM
MANDATORY BID SUBMITTAL FORM

OFFEROR/FIRM: _____

For: **BID #22-048, USER FEE ROAD CONSTRUCTION - PLOVER DRIVE**

The undersigned, having visited the site of the Work and having familiarized themselves with local conditions affecting the design and cost of the work and with all requirements of the proposed Contract Documents, and duly issued Addenda to said documents, as acknowledged herein, propose to furnish and perform all labor, materials, necessary tools, expendable equipment, and all utility and transportation services necessary to perform and complete in a workmanlike manner all work required by said documents and Addenda.

Georgetown County Water and Sewer District conflicts are shown on the U-sheets and quantities have been estimated on the Schedule of Values worksheet. The contractor is responsible for evaluating the work proposed and including all values in the base bid for Item (b) below.

1) **BASE BID PROPOSAL:** Bidder / Proposer agrees to perform all of the work described in the specifications, including allowances, and shown on the drawings, for the sum of:

a) Plover Drive:

_____ \$ _____
 (words shall govern)

b) Georgetown County Water and Sewer Relocations (see Special Provisions):

\$ _____ \$ _____
 (words shall govern)

c) Plover Drive Maintenance Stone (see Special Provisions):

\$ _____ X 100 TONS= _____ \$ _____
 (words shall govern)

d) Plover Drive Mucking (see Special Provisions):

\$ _____ X 100 CY = _____ \$ _____
 (words shall govern)

2) **SUMMARY BID TOTAL** (1a+1b+1c+1d):

\$ _____ + \$20,000 Utility Allowance = \$ _____

\$ _____

Total Bid Price (words shall govern)

3) **ALTERNATES:**

(not used)

- 4) For additional work authorized after signing the Contract, the amount of overhead and the amount of profit to be added to base costs of labor and materials shall not exceed 10% total for overhead and profit on work performed by the Contractor's own forces and shall not exceed 15% total on work by Subcontractors.
- 5) COMPLETION DATE: Contractor must conform to Division 0, Section 00750, Summary Schedule and Key Milestones.
- 6) LIQUIDATED DAMAGES: Liquidated damages for this project shall be \$500.00 per calendar day for Contractor's failure to complete any key milestone by its intermediate completion date or the Substantial Completion date. Refer to Division 1, Section 01100, Summary of Work.
- 7) The undersigned affirms that in making such Bid, neither he /she nor any company that they may represent, nor anyone in behalf of him / her or their company, directly or indirectly, has entered into any combination, collusion, undertaking or agreement with any other Bidder or Bidders to maintain the prices of said work, or any compact to prevent any other Bidder or Bidders from Bidding on said Contract or work and further affirms that such bid is made without regard or reference to any other Bidder or Proposer and without any agreement or understanding or combination either directly or indirectly with any other person or persons with reference to such Bidding in any way or manner whatsoever.
- 8) The undersigned, when notified of the acceptance of this Bid proposal, does hereby agree to enter into a Contract with the Owner within five (5) calendar days from the date of the Notice of Award, for the execution of the work described within the period of time allocated, and he / she shall give a Performance Bond and Payment Bond, with good and sufficient surety.
- 9) The undersigned further agrees that if awarded the Contract he /she will commence the work within ten (10) calendar days after the date of the Notice of Award and that he / she will complete the work in accordance with the Summary Schedule and Key Milestones and Substantial Completion date set forth in the Bidding and Contract Documents or such amended date as may be granted. If the undersigned fails to complete the work as provided in the aforementioned schedule, then and in that event, he / she further expressly agrees that, for each day that any phase of work under this Contract remains uncompleted thereafter the Owner may deduct from the Contract price herein specified the stipulated sum of liquidated damages as provided for herein and retain that sum for failure of the undersigned to complete this Contract on or before the expiration of the period shown in the completion schedule.
- 10) The undersigned agrees that the Owner's damages caused by delay are not capable of being established and would be difficult to measure accurately and that the sums herein specified as liquidated damages are not a penalty, but represent the parties' estimate of the actual damages which the Owner would suffer per day if the work is not completed as scheduled.
- 11) In submitting this Bid, it is understood that the right is reserved by the Owner to waive any informality or irregularity in any Bid or Bid guaranty, to reject any and all Bids, to re-Bid, to award or refrain from awarding a contract for the work and to negotiate with the apparent qualified low responsive Bidder to such extent as may be beneficial to the Owner.
- 12) The undersigned attaches hereto a cashier's check, certified check or Bid Bond in the sum five per-cent (5%) of the total base bid payable to Georgetown County, as required in the Request for Proposals, and the undersigned agrees that in case he / she fails within five (5) calendar days after Notice of Award of the Contract to him /her to enter into the Contract in writing and furnish the required Payment and Performance Bonds, with surety or sureties to be approved by Owner, and insurance policies or endorsements, the Owner may, as its option, determine that the undersigned has abandoned his / her rights and interest in such Bid and that the cashier's check, certified check, or Bid Bond accompanying his or her bid has been forfeited. Otherwise, the cashier's check, certified check, or Bid Bond shall be

returned to the undersigned upon the execution of the Contract and acceptance of the bonds and insurance, or upon rejection of his / her Bid.

- 13) A Bid shall be considered unresponsive and shall be rejected if it fails to include fully executed statements or if the Bidder fails to furnish required data. When a determination has been made to award the Contract to a specific Contractor, such Contractor shall, prior to award, furnish such other pertinent information regarding his / her own employment policies and practices as well as those of his / her proposed prime contractor, subcontractors and consultants as the Owner may require.
- 14) The Bidder shall furnish similar statements executed by each of his / her prime contractor, first-tier and second-tier subcontractors and consultants whose contracts equal Ten Thousand Dollars (\$10,000.00) or more and shall obtain similar compliance by such prime contractor, subcontractors and consultants before awarding such contracts. No prime contractor or subcontract shall be awarded to any non-complying prime contractor and/or subcontractor.
- 15) It is understood and agreed that all workmanship and materials under all items of work are guaranteed for one (1) year from the date of Final Acceptance, unless otherwise specified.
- 16) The undersigned affirms that he / she has completed all of the blank spaces in the Bid Form, with an amount in words and numbers and agrees that where a discrepancy occurs between the prices quoted in words and/or in numbers the lowest figure quoted in words shall take precedence and govern when determining final costs or award of the Contract.
- 17) The undersigned affirms that wages not less than the minimum rates or wages, as predetermined for this project by the State of South Carolina were used in the preparation of this "Bid Form".
- 18) **REQUIRED FORMS:** There are specific forms required to be completed and submitted as part of the response to this Request for Proposals (RFP). The omission, whether inadvertent or not, of any one or more of these forms will cause the Bidder's / Proposer's response to be disqualified. The following forms identified as Exhibits to this RFP, shall be included in the response:

Exhibit A	Bid Form
Exhibit B	Acknowledgement of Addenda
Exhibit C	Non-Collusion Affidavit
Exhibit D	Indemnification
Exhibit E	List of Prime & Subcontractors
Exhibit F	Statement of Experience
Exhibit G	Unit Price Schedule
Exhibit H	Resident Certification for Preference
Exhibit I	Exceptions Page Form
Bid Bond	5% of total base bid

19) Project Mgr/NTP Contact Address: _____

20) Project Mgr/NTP Contact Person: _____

21) Telephone Number _____ Fax Number _____

22) E-Mail address _____

23) Remittance Address: _____

24) A/P Accounting Contact _____

25) Telephone Number _____ Fax Number _____

26) E-Mail address _____

27) Suspension and Debarment

Federal guidelines require grant recipients to obtain sufficient assurance that vendors are not suspended or debarred from participating in federal programs when contracts exceed \$25,000. By signing below you verify that no party to this agreement is excluded from receiving Federal contracts, certain subcontracts, and certain Federal financial and nonfinancial assistance and benefits, pursuant to the provisions of 31 U.S.C. 6101, note, E.O. 12549, E.O. 12689, 48 CFR 9.404, and each agency's codification of the Common Rule for Non-procurement suspension and debarment. [See <https://www.acquisition.gov/isdc-debarment-regulations><https://www.acqu>for additional information.]

28) If the bid is accepted, the required Contract must be executed within fifteen (15) days after receipt of written notice of formal award of Contract and Certificate of Insurance (COI) and Payment and Performance Bonds must be received.

29) Will you honor the submitted prices and terms for purchase by other departments within Georgetown County and/or by other government entities who participate in cooperative purchasing with Georgetown County, South Carolina?

Yes No

30) Acceptance of Invitation for Bid Content: The contents of the successful IFB/RFP are included as if fully reproduced herein. Therefore, the selected contractor must be prepared to be bound by his/her proposal as submitted.

31) RENEWAL OF CONTRACT

The continuation of the terms, conditions, and provisions of any resulting contract beyond the fiscal year is subject to approval and ratification by the Georgetown County Council and appropriation by them of the necessary money to fund said contract for each succeeding year.

32) CERTIFICATION REGARDING DRUG-FREE WORKPLACE:

The undersigned certifies that the vendor listed below will provide a "drug-free workplace" as that term is defined in Section 44-107-30 of the Code of Laws of South Carolina, 1976, as amended, by the complying with the requirements set forth in title 44, Chapter 107.

Yes No

33) Any attempt by the vendor to influence the opinion of County Staff or County Council by discussion, promotion, advertising, misrepresentation of the submittal or purchasing process or

any procedure to promote their offer will constitute a violation of the vendor submittal conditions and will cause the vendor's submittal to be declared null and void.

34) The lowest or any proposal will not necessarily be accepted and the County reserves the right to award any portion thereof. I/We, the undersigned, hereby confirm that all the above noted documents for Bid/Request for Proposal No. 22-048 were received.

35) MINORITY PARTICIPATION [INFORMATION ONLY]

(a) Is the bidder a South Carolina Certified Minority Business?

Yes No

(b) Is the bidder a Minority Business certified by another governmental entity?

Yes No

If so, please list the certifying governmental entity: _____

(c) Will any of the work under this contract be performed by a SC certified Minority Business as a subcontractor?

Yes No

If so, what percentage of the total value of the contract will be performed by a SC certified Minority Business as a subcontractor? _____%

(d) Will any of the work under this contract be performed by a minority business certified by another governmental entity as a subcontractor?

Yes No

If so, what percentage of the total value of the contract will be performed by a minority business certified by another governmental entity as a subcontractor?
_____%

(e) If a certified Minority Business is participating in this contract, please indicate all categories for which the Business is certified:

- Traditional minority
- Traditional minority, but female
- Women (Caucasian females)
- Hispanic minorities
- DOT referral (Traditional minority)
- DOT referral (Caucasian female)
- Temporary certification
- SBA 8 (a) certification referral
- Other minorities (Native American, Asian, etc.)

(If more than one minority contractor will be utilized in the performance of this contract, please provide the information above for each minority business.)

- 36) **ILLEGAL IMMIGRATION: Non-Construction (NOV. 2008):** (An overview is available at www.procurement.sc.gov) By signing your offer, you certify that you will comply with the applicable requirements of Title 8, Chapter 14 of the South Carolina Code of Laws and agree to provide to the State upon request any documentation required to establish either: (a) that Title 8, Chapter 14 is inapplicable to you and your subcontractors or sub-subcontractors; or (b) that you and your subcontractors or sub-subcontractors are in compliance with Title 8, Chapter 14. Pursuant to Section 8-14-60, "A person who knowingly makes or files any false, fictitious, or fraudulent document, statement, or report pursuant to this chapter is guilty of a felony, and, upon conviction, must be fined within the discretion of the court or imprisoned for not more than five years, or both." You agree to include in any contracts with your subcontractors language requiring your subcontractors to (a) comply with the applicable requirements of Title 8, Chapter 14, and (b) include in their contracts with the sub-subcontractors language requiring the sub-subcontractors to comply with the applicable requirements of Title 8, Chapter 14. [07-7B097-1]

37)

INFORMATION ONLY:

Our company accepts VISA government procurement cards.

If yes, list any upcharge for P-Card Payment? _____

Our company does not accept VISA government procurement cards.

38) Printed Name of person binding bid _____

39) Signature (X) _____

40) Date _____

NOTE: THE ENTIRE IFB PACKET NEED NOT BE RETURNED. Please be sure to provide all mandatory bid submittal forms as requested. Thank you.

[THE REMAINDER OF THIS PAGE IS INTENTIONALLY LEFT BLANK.]

“EXHIBIT B”



BID #22-048
USER FEE ROAD CONSTRUCTION- PLOVER DRIVE

ADDENDUM ACKNOWLEDGEMENT
Mandatory Submittal Form

COMPANY NAME: _____

- Addendum #1 Received Date: _____ Initialed By: _____
- Addendum #2 Received Date: _____ Initialed By: _____
- Addendum #3 Received Date: _____ Initialed By: _____
- Addendum #4 Received Date: _____ Initialed By: _____
- Addendum #5 Received Date: _____ Initialed By: _____
- Addendum #6 Received Date: _____ Initialed By: _____

[THE REMAINDER OF THIS PAGE IS BLANK]

“EXHIBIT C”

**FORM OF NON-COLLUSION AFFIDAVIT OF PRIME PROPOSER / BIDDER
(Mandatory Bid Submittal Form)**

NON-COLLUSION OATH _____)

COUNTY OF: _____)

STATE OF: _____)

Before me, the Undersigned, a Notary Public, for and in the County and State aforesaid, personally appeared _____ and made oath that the Offeror Herein, his agents, servants, and/or employees, to the best of his knowledge and belief have not in any way colluded with anyone for and on behalf of the Offeror, or themselves, to obtain information that would give the Offeror an unfair advantage over others, not have they colluded with anyone for and on behalf of the Offeror, or themselves, to gain any favoritism in the award of the contract herein.

SWORN TO BEFORE ME THIS

_____ DAY OF _____, 2023

 Authorized Signature of Offeror

NOTARY PUBLIC FOR THE

STATE OF: _____

My Commission Expires: _____

Print Name: _____

Address: _____

Phone Number: _____

(Note: Notary seal required for out-of-state offeror)

“EXHIBIT D”

**INDEMNIFICATION
(Mandatory Bid Submittal Form)**

The Bidder / Proposer will indemnify and hold harmless the Owner, Georgetown County, South Carolina and their agents and employees from and against all claims, damages, losses and expenses, including attorney’s fees, arising out of or resulting from the performance of the Work provided that any such claims, damages, loss, or expense is attributable to bodily injury, sickness, disease or death, injury to or destruction of tangible property, including the loss of use resulting there from, and is caused by any negligent or willful act or omission of the Bidder / Proposer, and anyone directly or indirectly employed by him/her or anyone for whose acts any of them may be liable.

In any and all claims against the Owner, Georgetown County, South Carolina or any of their agents and / or employees by an employee of the Bidder / Proposer, and anyone directly or indirectly employed by any of them, or anyone for whose acts any of them may be liable, the indemnification obligation shall not be limited in any way to the amount or type of damages, compensation or benefits payable by or for the Bidder / Proposer under the Worker’s Compensation Acts, Disability Benefit Acts, or other employee benefit acts.

The obligation of the Bidder / Proposer under this paragraph shall not extend to the liability of Georgetown County, South Carolina or its agents and / or employees arising out of the reports, surveys, Change Orders, designs or Technical Specifications.

BIDDER / PROPOSER: _____

BY: _____

DATE: _____

TELEPHONE NO.: _____

[THE REMAINDER OF THIS PAGE IS INTENTIONALLY LEFT BLANK.]

“EXHIBIT E”

**LIST OF PRIME AND SUBCONTRACTORS
(Mandatory Bid Submittal Form)**

The undersigned states that the following is a full and complete list of proposed prime contractor and subcontractors on this Project and the class of work to be performed by each, and that such list will not be added to nor altered without the written consent of the Owner.

Prime Contractor, Subcontractor Consultants and Address	Class of Work to be Performed
1) _____ _____	_____
2) _____ _____	_____
3) _____ _____	_____
4) _____ _____	_____
5) _____ _____	_____
6) _____ _____	_____

Date: _____ **Firm Name:** _____

Signed: _____ **Title:** _____

“EXHIBIT F”

**STATEMENT OF EXPERIENCE
(Mandatory Bid Submittal Form)**

The Bidder is requested to state below what work of similar scope and complexity he/she has successfully completed, and to provide references that will enable the Owner to judge his/her experience, skill and business standing and his/her ability to conduct the Work in conformance with the requirements of the Construction Contract Documents. The County requests a minimum of three (3) references from the Primary Contractor. The Bidder may provide additional references or print additional pages as needed if they so choose.

Project and Location

Reference

1) _____ _____ _____	_____ _____ _____
2) _____ _____ _____	_____ _____ _____
3) _____ _____ _____	_____ _____ _____
4) _____ _____ _____	_____ _____ _____
5) _____ _____ _____	_____ _____ _____

Dated: _____

Firm Name: _____

Signed: _____

Title: _____

“EXHIBIT G”

**UNIT PRICE SCHEDULE
(Mandatory Bid Submittal Form)**

When changes in the work are ordered by the Owner, and such changes involve the following items, the following unit prices will be used to calculate adjustments to the Contract Sum. These unit prices shall be for the Work as specified, including all labor, materials, equipment, accessories, shipping, preparation, insurance, testing, overhead, profit, applicable taxes, permits, fees, warranties and all other associated costs for the finished and completed Work. All unit prices for utility conduits shall include sweeps, bends, couplings, caps, fittings, etc. which shall be included in the unit price per linear foot. Unit prices for undercut soils shall include material in place, surveyed and compacted pursuant to the Contract Documents.

Submit unit price and proposal amount for the following items. This list may not include all components necessary to provide a completed product, therefore any applicable items necessary to provide a completed product should be considered in your unit price response.

In case of errors in the extension of prices, unit price governs. In case of error in summations, corrected bid amounts will be totaled and will govern.

Contractor shall be responsible for all necessary electric and water hookups.

Contractor shall make quantity take-offs using drawings to determine quantities to his satisfaction, reporting promptly any discrepancies which may affect bidding. This is not a comprehensive list of items included in the contract documents, and represents only a portion of the project total.

UNIT PRICE SCHEDULE (SEE NEXT PAGE)

UNIT PRICE SCHEDULE

SECTION	ITEM	ESTIMATED QUANTITY	UNIT	CONTRACTOR QUANTITY	UNIT PRICE
1031000	MOBILIZATION	1.000	LS		
1032010	BONDS AND INSURANCE	1.000	LS		
1052000	UTILITY RELOCATION	1.000	LS		\$20,000.00
1050800	CONSTRUCTION STAKES, LINES & GRADES	1.000	EA		
1071000	TRAFFIC CONTROL	1.000	LS		
1092000	AS-BUILT CONSTRUCTION PLANS	1.000	LS		
2011000	CLEARING & GRUBBING WITHIN RIGHT OF WAY	1.000	LS		
2031000	UNCLASSIFIED EXCAVATION	983.000	CY		
2033000	BORROW EXCAVATION	1,191.000	CY		
2081001	FINE GRADING	4,595.000	SY		
3050108	GRADED AGGREGATE BASE COURSE (8" UNIFORM)	3,590.000	SY		
3100320	HOT MIX ASPHALT BASE COURSE TYPE B	26.000	TON		
4010005	PRIME COAT	900.000	GAL		
4011004	LIQUID ASPHALT BINDER PG64-22	23.000	TON		
4020320	HOT MIX ASPHALT INTERMEDIATE COURSE TYPE B	11.000	TON		
4030340	HOT MIX ASPHALT SURFACE COURSE TYPE C	350.000	TON		
6051120	PERMANENT CONSTRUCTION SIGNS (GROUND MOUNTED)	152.000	SF		
6250025	24" WHITE SOLID LINES (STOP)-FAST DRY PAINT	44.000	LF		
6250110	4"YELLOW SOLID LINE -FAST DRY PAINT	460.000	LF		
6271025	24" WHITE SOLID LINES (STOP/DIAG LINES) THERMO- 125 MIL.	22.000	LF		
6271074	4" YELLOW SOLID LINES(PVT/ EDGE LINES) THERMO- 90 MIL.	230.000	LF		
7141112	15" RC PIPE CUL.-CLASS III	340.000	LF		
7141114	24" RC PIPE CUL.-CLASS III	48.000	LF		
7141122	15" RC PIPE CUL.-CLASS IV	68.000	LF		
7199100	BEVELING OF PIPE END (IN SCDOT R/W)	2.000	EA		
8011450	AGGR. UNDERDRAIN 57 STONE (FOR PIPE BEDDING)	30.000	TON		
8041020	RIP-RAP (CLASS B)	42.000	TON		
8100100	PERMANENT COVER	0.900	AC		
8100200	TEMPORARY COVER	0.900	AC		
8104005	FERTILIZER (NITROGEN)	90.000	LBS		
8104010	FERTILIZER (PHOSPORIC ACID)	90.000	LBS		
8104015	FERTIZILER (POTASH)	90.000	LBS		
8105005	AGRICULTURAL GRANULAR LIME	1,800.000	LBS		
8109050	SELECTIVE WATERING	54,300.000	GAL		
8109901	MOWING	1.800	AC		
8151203	HYDRAULIC EROSION CONTROL PRODUCT (HECP) - TYPE 3	4.356	MSY		
8152007	SEDIMENT TUBES FOR DITCH CHECKS	200.000	LF		
8153000	SILT FENCE	350.000	LF		
8156490	STABILIZED CONSTRUCTION ENTRANCE	270.000	SY		
Georgetown County Water and Sewer Quantities					
GCWS01	GRINDER UNIT RELOCATION	1.000	EA		
GCWS02	GRINDER SERVICE LINE (RELOCATION UNDER PROPOSED DITCH)	2.000	EA		
GCWS03	4" PVC WATER LINE C-900 SDR 18	1,250.000	LF		
GCWS04	POST HYDRANT RELOCATION	1.000	EA		
GCWS05	RE-TAP AND RE-ESTABLISH WATER SERVICE TO NEW LINES	6.000	EA		

Bidder/Proposer: _____

Signature: _____

Title: _____

Dated: _____

[THE REMAINDER OF THIS PAGE IS INTENTIONALLY LEFT BLANK.]



“EXHIBIT H”

RESIDENCE CERTIFICATION FOR LOCAL PREFERENCE MANDATORY VENDOR SUBMITTAL FORM

WHEREAS, Georgetown County Council desires to further its support of local businesses when awarding contracts for the provision of supplies and construction services to the County through its established procurement procedures.

THEREFOR pursuant to Georgetown County, SC Ordinance #20-32, §2-50 Local Preference, the Georgetown County Purchasing Officer requests each offeror provide Residence Certification. The Local Preference Option provides some restrictions on the awarding of governmental contracts; provisions of which are stated below:

Sec 2-50. Local Preference

1. A vendor shall be deemed a Local Georgetown County vendor for the purposes of this Section if such vendor is an individual, partnership, association or corporation that is authorized to transact business within the State, maintains an office in Georgetown County, and maintains a representative inventory or commodities within the County on which the bid is submitted, and has paid all taxes duly assessed.
2. This option allows the lowest local Bidder whose bid is within five-percent (5%) of the lowest non-local Bidder to match the bid submitted by the non-local Bidder and thereby be awarded the contract. This preference shall apply only when (a) the total dollar purchase is greater than \$30,000; (b) the vendor has a physical business address located and operating within the limits of Georgetown County and has been doing business in the County for a period of twelve (12) months or more; and (c) the vendor provides proof of payment of all applicable Georgetown County taxes and fees if so requested.
3. Should the lowest responsible and responsive Georgetown County bidder not exercise its right to match the bid as granted herein, the next lowest qualified Georgetown County bidder shall have that right and so on. The right to exercise the right to match the bid shall be exercised within 24 hours of notification of the right to match the non-Georgetown County bidder's bid.
4. In order to qualify for the local preference authorized by this Section, the vendor seeking same shall be required to submit with its bid a statement containing relevant information which demonstrates compliance with the provisions of this Section. This statement shall be on a form provided by the County purchasing department and shall be signed under penalty of perjury. Failure to provide such affidavit at the time the bidder submits its bid shall constitute a waiver of any claim for preference.
5. For all contracts for architecture, professional engineering, or other professional services governed by Section 2-56, Architect-Engineer and Land Surveying Services – Public Announcement and Selection Process, the county shall include the local business status of a firm among the factors considered when selecting which firms are “most highly qualified.” In determining which firm is the “most qualified” for purposes of

negotiating a satisfactory contract, preference shall be given to a local business where all other relevant factors are equal.

6. Local preference shall not apply to the following categories of contracts:

- (a) Goods or services provided under a cooperative purchasing agreement or similar “piggyback” contract;
- (b) Contracts for professional services except as provided for in section five (§5) above;
- (c) Purchases or contracts which are funded, in whole or in part, by a governmental or other funding entity, where the terms and conditions of receipt of the funds prohibit the preference;
- (d) Purchases or contracts made pursuant to a noncompetitive award process, unless otherwise provided by this section; or
- (e) Any bid announcement which specifically provides that the general local preference policies set forth in this section are suspended due to the unique nature of the goods or services sought, the existence of an emergency as found by either the county council or county administrator, or where such suspension is, in the opinion of the county attorney, required by law.

I certify that [Company Name] _____

is a **Resident Bidder** of Georgetown County as defined in Ordinance #20-32, (see §1. above)

and our local place of business within Georgetown County is: _____

I certify that [Company Name] _____

is a **Non-Resident Bidder** of Georgetown County as defined in Ordinance #20-32, and our principal place of business is _____ [City and State].

(X) _____

Signature of Company Officer

“EXHIBIT I”

EXCEPTIONS PAGE

MANDATORY BID SUBMISSION FORM

List any areas where you cannot or will not comply with the specifications or terms contained within the bid documentation.

END OF SECTION 00300

SECTION 00400

BID BOND

Submit one (1) original, Power of Attorney, and Agent’s Current South Carolina license.

STATE OF _____)

COUNTY OF _____)

KNOW ALL MEN BY THESE PRESENT that we, _____

as Principal, and _____ as Surety, are

held and firmly bound unto Georgetown County, hereinafter called the Owner,

in the sum of _____ Dollars

(\$ _____) for the payment of which sum well and

to be made, we bind ourselves, our heirs, executors, administrators, successors, and assigns,

jointly and severally firmly by these presents.

WHEREAS, the Principal, on the _____ day of _____, 2023 entered into a

certain Contract with the Owner, hereto attached, for Contract entitled **Bid #22-048, USER FEE ROAD CONSTRUCTION - PLOVER DRIVE.**

NOW THEREFORE, If the Principal shall not withdraw said Bid within NINETY (90) calendar days after date of opening of the same, and shall within five (5) calendar days after the prescribed forms are presented to him/her for signature, enter into a written Contract with the Owner in accordance with the Bid as accepted, and give a Performance Bond and a Payment Bond with good and sufficient surety or sureties, as required by the Contract Documents, for the faithful performance and proper fulfillment of such Contract and for the proper payment of all persons furnishing labor or materials in connection therewith, or in the event or withdrawal of said Bid within the period specified, or in the event of failure to enter into such Contract and give such Bonds within the time specified, if the Principal shall pay the Owner the difference between the amount specified in said Bid and the amount of which the Owner may procure the required work and/or supplies, provided the latter amount be in excess of the former then the above obligations shall be void and of no effect; otherwise, to remain in full force and effect.

IN WITNESS WHEREOF, the Principal and Surety have hereunto caused this Bond to be duly executed

and acknowledged by their appropriate officials as set forth below this _____ day of _____, 2023.

PRINCIPAL (If Sole Proprietor or Partnership)

(Firm Name)

ATTEST

By: _____
(SEAL)

_____ Title (Sole Proprietor or Partner)

PRINCIPAL (If Corporation)

_____ (Corporate Name)

By: _____ (President)

Attest: _____ (Secretary)

(Impress Corporate Seal)

COUNTERSIGNED BY
RESIDENT SOUTH CAROLINA
AGENT OF SURETY:

SURETY:

(Copy of Agent's current license
as issued by State of South Carolina
Insurance Commissioner

By: _____
Attorney-In-Fact
(Power of Attorney Must Be Attached)

(Impress Corporate Seal)

END OF SECTION 00400

STATE OF SOUTH CAROLINA) **CONSTRUCTION**
)
GEORGETOWN COUNTY) **CONTRACT**

THIS CONTRACT made and entered into this _____ day of _____ 20____, by and between Georgetown County, hereinafter referred to as the “Owner”, a body politic and corporate and political subdivision of the State of South Carolina, whose administrative address is: 129 Screven Street, Georgetown, South Carolina 29440; and _____ hereinafter referred to as the “Contractor”, a corporation formed and existing under the laws of the State of South Carolina and authorized to do business within the State of South Carolina, whose administrative address is: _____

IN WITNESS WHEREOF:

WHEREAS the Owner has a project entitled _____ hereinafter referred to as the “Project”, and;

WHEREAS, the Contractor has submitted a quotation for the Project at \$ _____ and the Owner has awarded the Project to the Contractor, and

NOW, THEREFORE, in consideration of the mutual promises and covenants contained herein, as well as other good and valuable consideration not specifically mentioned, the parties agree as follows:

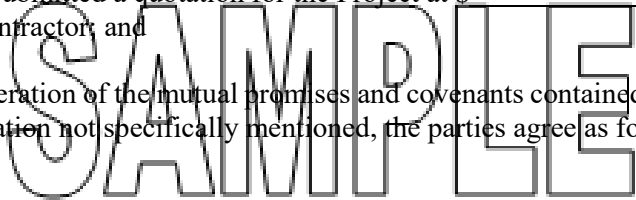

- 1. The Contractor, for and in consideration of the payments hereinafter specified and agreed to be made by the Owner, hereby covenants and agrees to furnish and deliver all materials required, to do and perform all the work and labor, in a satisfactory and workmanlike manner, required to complete the Project within the time specified, in strict and entire conformity with the Plans, Technical Specifications and other Contract documents, on file at Georgetown County, which are duly approved by the Owner and which said Plans, Specifications and other Contract documents are hereby made part of this Contract as fully and with the same effects as if the same had been set forth at length in the body of this Contract.
- 2. The Contractor hereby agrees to indemnify, defend and hold the Owner and, the Engineer, and each of their agents, representatives, directors, officers, and employees harmless from any and all liabilities, losses, damages, penalties, judgments, awards, claims, demands, costs, expenses, (including reasonable attorney’s fees and court costs), actions, lawsuits or other proceedings arising directly or indirectly, in whole or in part, out of the negligence or willful acts or omissions of the Contractor, Trade Subcontractors, or their respective agents, directors, officers or employees in connection with this Agreement or in any way with the services or Work described herein, any occurrence at the Project site, or any occurrence arising in connection with or at the Project site or in connection with the Work, whether within or beyond the scope of its duties hereunder.
- 3. The Project has been designed by _____ whose office is located at _____, and who will act as ENGINEER in connection with completion of the Work in accordance with the Contract Documents.

4. The project will be considered substantially complete upon completion of all items listed in the Bid Form and appurtenances in accordance with the Contract Documents, including successful performance of all testing requirements.
5. The Contractor's indemnity and defense obligations under this Contract shall be absolute notwithstanding any provision contained herein or elsewhere to the contrary, and shall survive Final Completion and Final Payment for a period equal to the statute of limitations for any action which could be brought against the Owner or its agents, officers, directors and employees and shall continue through the duration of any action brought during the applicable time periods.
6. The Contractor agrees to indemnify, defend and hold the Owner, and the Engineer, and each of their agents, representatives, officers, directors and employees, harmless from all costs, damages and expenses, including reasonable attorney's fees, incurred by the Owner and its consultants by virtue of any claim or claims filed by any Trade Subcontractor, mechanic, laborer, or materialman making claims arising from the performance of the Work by, through, or under the Contractor, provided the Contractor has received from the Owner all amounts properly due under this Contract concerning the claim. The Contractor shall execute and deliver to the Owner's title insurer similar indemnifications or such other document as such title insurer shall reasonably request in order to protect it against lien claims from Trade Subcontractors. The Contractor also hereby agrees to indemnify and hold harmless, protect and defend the Owner and its consultants from and against any liability, claim, judgment, loss or damage, including, but not limited, to direct damages, attorney's fees, court costs and expenses of collection, occasioned in whole or in part by the sole failure of the Contractor, and its Trade Subcontractors to comply with any of the terms or provisions of this Contract.
7. In any and all claims against the Owner, by any employee of the Contractor or Trade Subcontractor, anyone directly or indirectly employed by any of them, their agent or anyone for whose acts any of the Contractor or Trade Subcontractors may be liable, the indemnification obligation under this Paragraph 2 shall not be limited in any way by any limitation on the amount or type of damages, compensation or benefits payable by or for the Contractor or any Trade Subcontractor under workers' or workmen's compensation acts, disability benefit acts or other employee benefit acts.
8. The Owner hereby agrees to pay to the Contractor for the said work, when fully completed, the total sum of _____ (the said sum being the total of the Contractor's bid, a copy of which is attached hereto and, pro tanto, made a part hereof for all purposes), subject to such additions and deductions as may be provided for in the Contract Documents. In the event the bid contains multiple pay items, it is understood that the amount to be paid shall be the total based on the unit prices, together with lump sum prices, contained in said bid, for the work actually completed. Payments on accounts will be made as customarily provided by the County and consistent with applicable County procedures. The Contractor shall submit bills for fees or other compensation for services or expenses in detail sufficient for a proper pre-audit and post audit thereof. Any unit of provision of goods and services must be approved in writing by the Owner prior to payment.
9. The Owner may unilaterally cancel this Contract and the goods and services there under in the event that the Contractor fails and refuses to allow public access to all documents, papers, letters, or other material subject to the provisions of the applicable South Carolina Code of Laws, made or received by the Contractor in conjunction with this Contract.
10. This Contract has been executed by the parties prior to the rendering of any goods or services by the Contractor.
11. The Contractor shall provide a payment and performance bond (the "Bond") to the Owner meeting the requirements of applicable South Carolina Code of Laws, The Georgetown County Procurement Ordinance, as amended, and associated bid documents referenced herein, which by virtue of executing

this contract the Contractor has accepted in the sum of \$ _____ and shall cause the Bond to be recorded with the Notice of Commencement in the Public Records of Georgetown County, South Carolina.

12. This Contract shall be subordinate to any rule, regulation, order or law of the United States of America, or the State of South Carolina, respectively.
13. Contractor and its employees shall promptly observe and comply with all applicable provisions of any Federal, State and local laws, ordinances, rules or regulations which govern or apply to the goods or services rendered by Contractor hereunder including the wages paid by Contractor to its employees. Contractors shall require all of its Subcontractors to comply with the provisions of this paragraph.
14. Contractor shall procure and keep in force during the term of this contract all necessary insurance (including but not limited to general liability, casualty, workers compensation, and automobile), licenses, registrations, certificates, permits and other authorizations as are required by law in order for Contractor to render its services hereunder. Contractor shall require all of its Subcontractors to comply with the provisions of this paragraph.
15. All remedies provided in this Contract shall be deemed cumulative and additional and not in lieu of or exclusive of each other or of any other remedy available to any party at law or in equity. In the event one party shall prevail in any action (including appellate proceedings), at law or in equity arising hereunder, the losing party will pay all costs, expense, reasonable attorneys' fees and all other actual and reasonable expenses incurred in the defense and/or prosecution of any legal or arbitration proceedings, including, but not limited to, those for paralegal, investigative, legal support services and actual fees charged by expert witnesses for testimony and analysis, incurred by the prevailing party referable thereto.
16. Contractor represents and warrants unto Owner that no officer, employee or agent of Owner has any interest, either directly or indirectly, in the business or property for/on which the Contractor to conduct activities hereunder. Contractor further represents and warrants to Owner that it has not employed or retained any third party person, other than a bona fide employee working solely for Contractor, to bid, solicit or secure this Contract, that it has not paid or agreed to any person, company, corporation, individual or firm, other than a bona fide employee working solely for Contractor, any fee, commission, percentage, gift, or any other consideration contingent upon or resulting from the award or making of this Contract, and that it has not agreed, as an express or implied condition for obtaining this Contract, to employ or retain the services of any firm or person in connection with carrying out this Contract. Contractor assures that it will insert the above provision in each of its Subcontractor agreements relating to the services to be performed hereunder.
17. The headings of the sections of this Contract are for the purpose of convenience only and shall not be deemed to expand or limit the provisions contained in such sections.
18. This Contract, including all Contract documents such as, but not limited to, bid documents and procurement packages, constitutes the entire agreement between the parties and shall supersede and replace all prior agreements or understandings, written or oral, relating to the matters set forth herein.
19. This Contract shall not be amended or modified other than in writing signed by the parties hereto. Notwithstanding the foregoing, any Amendments that are not being paid for, in whole or in part, with funds granted by the United States or State of South Carolina need not be approved by them.
20. The validity, interpretation, construction and effect of this Contract shall be in accordance with and be governed by the laws of the State of South Carolina. In the event any provision hereof shall be finally

determined to be unenforceable, or invalid, such unenforceability or invalidity shall not affect the remaining provisions of this Contract which shall remain in full force and effect.

21. Termination of Contract

- a) The Owner may, by written notice, terminate this Contract in whole or in part at any time, either for the Owner's convenience or because of failure to fulfill the Contract obligations. Upon receipt of such notice, services shall be immediately discontinued (unless the notice directs otherwise) and all materials that may have been accumulated in performance of this Contract, whether completed, in transit, or in process, shall be delivered to the Owner. In such a case of termination, the contract price shall be made and remitted too include work already completed and materials already ordered however to amount shall be allowed for anticipated profit on unperformed services.
- b) If the termination is due to failure to fulfill the Contractor's obligations, the Owner may take over the work and prosecute the same to completion by contract or otherwise. In such case, the Contractor shall be liable to the Owner for any additional cost occasioned to the Owner thereby.
- c) If, after notice of termination for failure to fulfill its Contract obligations, it is determined that the Contractor had not failed, the termination shall be deemed to have been effected for the convenience of the Owner. In such event, adjustment in the Contract price shall be made as provided in paragraph 21.a of this clause.
- d) The rights and remedies of the Owner provided in this clause are in addition to any other rights and remedies provided by law or under this Contract.
- e) Non-Appropriation:
It is understood and agreed by the parties that in the event funds are not appropriated in the current fiscal year or any subsequent fiscal years, this contract will become null and void and the County will only be required to pay for services completed to the satisfaction of the County.

22. Waiver or Forbearance

Any delay or failure of County to insist upon strict performance of any obligation under this Agreement or to exercise any right or remedy provided under this Agreement shall not be a waiver of County's right to demand strict compliance, irrespective of the number or duration of any delay(s) or failure(s). No term or condition imposed on Contractor under this Agreement shall be waived and no breach by Contractor shall be excused unless that waiver or excuse of a breach has been put in writing and signed by both parties. No waiver in any instance of any right or remedy shall constitute waiver of any other right or remedy under this Agreement. No consent to or forbearance of any breach or substandard performance of any obligation under this Agreement shall constitute consent to modification or reduction of the other obligations or forbearance of any other breach.

23. Title VI Compliance:

Georgetown County hereby gives public notice that it is the policy of the agency to assure full compliance with Title VI of the Civil Rights Act of 1964, the Civil Rights Restoration Act of 1987, Executive Order 12898 on Environmental Justice, and related statutes and regulations in all programs and activities. Title VI requires that no person in the United States of America shall, on the grounds of race, color, or national origin, be excluded from the participation in, be denied the benefits of, or be otherwise subjected to discrimination under any program or activity for which Georgetown County receives federal financial assistance. Any person who

believes they have been aggrieved by an unlawful discriminatory practice under Title VI has a right to file a formal complaint with Georgetown County. Any such complaint must be in writing and filed with Georgetown County's Title VI Coordinator within one hundred and eighty (180) days following the date of the alleged discriminatory occurrence. For more information, or to obtain a Title VI Discriminatory Complaint Form, please see our website at <http://www.gtcounty.org>.

[THE REMAINDER OF THIS PAGE IS INTENTIONALLY LEFT BLANK.]

SAMPLE

IN WITNESS WHEREOF, the Owner and Contractor hereto have signed and sealed this Contract on the day and date first above written. To facilitate execution, this Agreement may be executed, including electronically, in as many counterparts as may be required. It shall not be necessary that the signature on behalf of both parties hereto appear on each counterpart hereof. All counterparts hereof shall collectively constitute a single agreement.

Georgetown County, South Carolina

Witness:

By: _____
Louis Morant
Georgetown County Council Chair

[Company Name]

By: _____

(Title)

Attest:

SAMPLE

SECTION 00600

PERFORMANCE BOND

BOND NO. _____

KNOW ALL MEN BY THESE PRESENTS that we, _____ as Principal, and _____ as Surety, are held and firmly bound unto Georgetown County, South Carolina hereinafter called the Obligee, in the Penal sum of _____ Dollars (\$ _____) for the payment of which sum well and truly to be made, we bind ourselves, our heirs, executors, administrators, successors, and assigns, jointly and severally firmly by these presents.

WHEREAS, the Principal, on the _____ day of _____, 2023 entered into a certain Contract with the Owner, included herein, for the Contract entitled **Bid #22-048, USER FEE ROAD CONSTRUCTION - PLOVER DRIVE.**

NOW THEREFORE, the condition of this obligation is such that if the Principal shall well and truly perform and fulfill all the undertakings, covenants, terms, conditions, and agreements of said Contract, and all duly authorized modifications of said Contract that may hereafter be made, notice of which modifications to the Surety being hereby waived, then this obligation shall be void; otherwise, to remain in full force and effect.

Whenever the Principal shall be and is declared by the Owner to be in default under the Contract, or wherever the contract has been terminated by default of the Contractor, the Owner having performed the Owner's obligations hereunder, the Surety shall:

1. Complete the Contract in accordance with its terms and conditions, or at the Owner's sole option.
2. Obtain a Bid or Bids for submission to the Owner for completing the Contract in accordance with its terms and conditions, and upon determination by the Owner and Surety of the lowest responsible Bidder, arrange for a Contract between such Bidder and the Owner, and made available as work progresses (even though there should be a default or a succession of defaults under the Contract or Contracts of completion arranged under this paragraph) sufficient funds to pay the cost completion less the balance of the Contract price but not exceeding, including other costs and damages for which the Surety may be liable hereunder, the amount set forth in the first paragraph hereof. The term balance of the Contract price: as used in this paragraph, shall mean the total amount payable by the Owner to the Contractor under the Contract and any amendments thereto, less the amount properly paid by the Owner to the Contractor.

No right of action shall accrue on this Bond to or for the use of any person or corporation other than the Owner named herein or the successors or assignees thereof.

In the case of termination of the Contract, as provided in the Contract Documents, there shall be assessed against the Principal and Surety herein, all expenses, including design/engineering, geo-technical, surveying, and legal services incidental to collecting losses to the Owner under this Bond.

This Bond shall remain in full force and effect for such period or periods of time after the date of acceptance of the project by the Owner as are provided for in the Contract Documents, and the Principal

hereby guarantees to repair or replace for the said periods all work performed and materials and equipment furnished, which were not performed or furnished according to the terms of the Contract Documents. If no specific periods of warranty are stated in the Contract Documents for any particular item of work, material, or equipment, the Principal hereby guarantees the same for a minimum period of one (1) year from the date of final acceptance by the Owner.

The Surety shall permit arbitration and be ultimately responsible for the payment of any award.

IN WITNESS WHEREOF, the above bounden parties have caused this Bond to be signed and sealed by their appropriate officials as of the _____ day of _____, 2023.

PRINCIPAL

(Firm Name)

By: _____
(Title)

WITNESS

SURETY

(Firm Name)

By: _____
(Title)

WITNESS

END OF SECTION 00600

SECTION 00601

LABOR AND MATERIAL PAYMENT BOND

BOND NO. _____

KNOW ALL MEN BY THESE PRESENTS that we, _____ as Principal, and _____ as Surety, are held and firmly bound unto Georgetown County, South Carolina hereinafter called the Obligee, in the Penal sum of _____ Dollars (\$ _____) for the payment of which sum well and truly to be made, we bind ourselves, our heirs, executors, administrators, successors, and assigns, jointly and severally firmly by these presents.

WHEREAS, the Principal, on the ____ day of _____, 2023 entered into a certain Contract with the Owner, included herein, for Contract entitled **Bid #22-048, USER FEE ROAD CONSTRUCTION-PLOVER DRIVE.**

NOW THEREFORE, the condition of this obligation is such that if the Principal shall promptly make payments to all persons supplying labor, materials and supplies used directly or indirectly by said Principal or his Subcontractors in the prosecution of the work provided for in said Contract, then this obligations shall be void; otherwise to remain in full force and effect, subject, however, to the following conditions:

1. This bond is executed for the purpose of complying with the applicable State of South Carolina Statutes and all acts amendatory thereof, and this Bond shall inure to the benefit of any and all persons supplying labor, material and supplies used directly or indirectly by the Principal or his Subcontractors in the prosecution of the work provided for in said Contract so as to give such persons a right of action to recover upon this Bond in a separate suit brought on this Bond. No right of action shall accrue hereunder to or for the use of any person except as such right of action may be given and limited by the applicable State of South Carolina Statutes.
2. In each and every suit brought against the Principal and Surety upon this Bond in which the plaintiff shall be successful, there shall be assessed therein against the Principal and Surety herein, in favor of the Plaintiff therein, reasonable counsel fees, which the Principal and Surety hereby expressly agree to pay as a part of the cost and expense of said suit.
3. A claimant, except a laborer, who is not in privity with the Principal and who has not received payment for his labor, materials, or supplies, shall, within forty-five (45) calendar days after beginning to furnish labor, materials, or supplies for the prosecution of the work, furnish the Principal with a notice that he intends to look to the bond for protection.
4. A claimant who is not in privity with the Principal and who has not received payment for his labor, materials or supplies shall, within ninety (90) calendar days after performance of the labor or after complete delivery of the materials or supplies, deliver to the Principal and to the Surety written notice of the performance of the labor or delivery of the materials or supplies and of the non-payment.
5. No action for the labor, materials, or supplies may be instituted against the Principal or the Surety unless both notices have been given. No action shall be instituted against the Principal or the Surety on the bond after one (1) year from the performance of the labor or completion of delivery of the materials or supplies.

The Surety shall permit arbitration and be ultimately responsible for the payment of any award.

IN WITNESS WHEREOF, the above bounden parties have caused this Bond to be signed and sealed by their appropriate officials as of the _____ day of _____, 2023.

PRINCIPAL

(Firm Name)

(Witness)

By: _____
(Title)

SURETY

(Firm Name)

(Witness)

By: _____
(Title)

END SECTION 00601

SECTION 00750

SUMMARY SCHEDULE AND KEY MILESTONES

1.0 GENERAL

1.01 THIS SECTION INCLUDES

- A. Summary Submittals
- B. Key Milestones
- C. Base Bid Summary Schedule
- D. Alternate Summary Schedule (If Applicable)

1.02 SUMMARY SCHEDULE

- A. Summary Schedules referred to in this section will be developed by the Contractor and the Owner illustrating an approach to designing and constructing the project. The activities to be shown on the schedules will be monitored and updated.
- B. Milestones shown on the Summary Schedules will be “Key Milestones” and are to be included in the Contractor’s Contract Schedule. The Contractor is responsible to develop his/her own activities and logic to meet the required Key Milestone Intermediate Dates. Refer to Division 1, Section 01310, Project Management and Coordination.

1.03 KEY MILESTONES

- A. Key Milestones shall be included in all Contractor Schedules and show completing on the intermediate dates shown in this Section.
- B. Key Milestones are a contractual requirement and liquidated damages as specified in *The Project Manual, Vol. 1, Division 1, Section 01100, Summary of Work*, will be assessed for each Key Milestone that completes beyond the dates listed below. Refer to Division 1, Section 01100 and Summary of Work.
- C. Key Milestones for the Base Bid are as follows:

Milestone: **Substantial Completion**

Date: 210 Days from NTP

Milestone: **Final Completion**

Date: 240 Days from NTP

END OF SECTION 00750

SECTION 00800

SPECIAL PROJECT CONDITIONS

1.0 PURPOSE

The Special Project Conditions are intended to identify those elements of work and items of material, and responsibilities of the Contractor, which are unique to the project and required by the Contract Documents. They are intended to supplement those contractual requirements contained within the Contract Documents including, but not limited to: the Contract; Division 1, General Requirements, Drawings and Technical Specifications.

2.0 SAFETY AND SECURITY

2.0.1 ENTRY ONTO THE PROJECT SITE

The Contractor shall be responsible for the security of all materials and equipment to be used for the Work of the Project. Vehicles to be allowed on the Project site will include only those of the Contractor, prime and sub-contractors and those designated by the Owner. Contractor shall have sole responsibility for the safety of vehicles in close vicinity and within the projects Limits of Disturbance.

2.0.2 STORAGE / STAGING AREA

All construction material, either the Contractor's, prime and sub-contractor's vehicles and equipment, and personal vehicle parking areas will be established and regulated by the Contractor and approved by the Owner. Staging and storage areas will not be provided by the Owner. Coordination of deliveries and storage will be determined during the pre-construction conference.

2.0.3 OPEN TRENCHES

All open trenches and excavations within the project site shall be marked per the requirements of MUCTD and any referenced Standard Drawings for Traffic Control.

2.0.4 SECURITY

The Contractor shall be responsible for the security of his/her equipment and materials, as well as the security of the equipment and materials of his agents prime and sub-contractors. Further, he/her shall be responsible for the security of all gates and entrances to the Project site. The gates shall be locked at all times, or guards posted at the gates to control ingress and egress through them. The Contractor shall provide adequate lighting for the entire area of the Project site.

The Contractor shall provide to Owner a list of all his/her employees as well as a list of all the employees of the prime and sub-contractors and shall, during the work of the Project, advise the Owner of changes to the list of personnel working on the Project. The Contractor shall be responsible for the direct supervision of his/her employees, those of his agents, prime and sub-contractors at all times while on the Project site.

The Contractor shall exercise and take all precautions in the storage and dispensing of all flammable liquids such as, but not limited to, gasoline, diesel fuel and lubricants.

3.0 SURFACE INFORMATION AND MATERIALS INSPECTION

The Contractor shall have full responsibility for acquisition, interpretation, analysis and cost impact of sub-surface conditions in the performance of the Work required by this contract. The Contractor shall provide, to the Owner, written certification that all materials and equipment meet the design requirements, established in the drawings and technical specifications for permitting and are in conformance with the Construction Documents. Copies of all test, inspection and certification reports shall be submitted to the Owner within twenty-four (24) hours of receipt of such reports by the Contractor.

4.0 PAVEMENT

The Contractor shall be responsible for all roadways adjacent to or on the project site over which his, his agents prime and / or sub-contractors vehicles may travel. The Contractor shall at his sole cost and expense, repair any damage caused by operation of equipment or hauling of debris on any and all roads off of the project site used to travel on.

5.0 PROJECT SIGN

N/A

6.0 PROJECT PROGRESS PHOTOGRAPHS

N/A

7.0 LANDSCAPING AND TREES

The contractor shall be responsible for all landscaping and / or trees damaged due to negligence incurred by his / her operations.

PART 2- PRODUCTS

Not Used

PART 3- EXECUTION

Not Used

END OF SECTION 00800

SECTION 00900

LIST OF DRAWINGS & TECHNICAL SPECIFICATIONS

Bid #22-048, USER FEE ROAD CONSTRUCTION - PLOVER DRIVE

I - LIST OF DRAWINGS:

<u>SHEET NO.</u>	<u>DESCRIPTION</u>	<u>SHEET TOTALS</u>
<u>Plover Drive Construction Plans</u>		
1	Title Sheet	1
3	Typical Sections	1
5	General Construction Notes Sheet	1
5A	Survey Control Sheet	1
6-8	Plan Sheets	3
9-10	Profile Sheets	2
PM1	Pavement Marking Sheet	1
U1-U3	Utility Sheets	3
EC1-EC5	Erosion Control Sheets	5
X1-X8	Cross Sections	8
D1-D4	Standard Drawings Sheets	4

Plans and Drawings should be plotted to 22" X 36" to maintain scale.

II - LIST OF ADDITIONAL ATTACHMENTS:

TITLE

PERMITS

GEORGETOWN COUNTY WATER AND SEWER SPECIFICATIONS

END OF SECTION 00900

SECTION 01100 SUMMARY OF WORK

PART 1-GENERAL

The Summary of Work in this Section comprises the **USER FEE ROAD CONSTRUCTION - PLOVER DRIVE** project in Georgetown County, South Carolina. The following scope of work description is intended to be general in nature. The intention is to have the successful Contractor perform all of the work included and presented within the Contract Documents, paying particular attention to the Summary Schedule, Key Milestones in Division 0, Section 00750. The Contractor shall comply with and be responsible for all of the requirements of the Project Manual. The Drawings and Technical Specifications are not intended to indicate or describe all work, or means and method of construction required for completion of the Work. The Contractor shall provide and install all incidentals that are required for completion of the Work.

The Work Consists Of: re-grading, placing base course, and paving Plover Drive totaling approximately 0.25 miles. Quantities for this project are approximately 3,590 square yards of 8" Graded Aggregate Base Course, 983 cubic yards of Unclassified Excavation, 1,191 cubic yards of Borrow Excavation, Clearing and Grubbing within project limits, 350 Tons of Hot Mix Asphalt Surface Course Type C (200 lbs./square yard), 11 Tons of Hot Mix Asphalt Intermediate Course Type B (200 lbs./square yard), 26 Tons of Hot Mix Asphalt Base Course Type B (450 lbs./square yard), 456 linear feet of RC storm drainage pipe ranging in size from 15" to 24" RCP.

1.01 RELATED REQUIREMENTS INCLUDED

- A. Project Manual, Division 0, Bidding and Contract Documents
- B. Project Manual, Division 1, General Requirements
- C. The Contractor shall comply with and be responsible for all of the requirements of the Project Manual, without exception.
- D. The Contract Form for this Project shall be as stipulated in Division 0, Section 00500 in the Project Manual.

1.02 SCOPE OF WORK AND USE OF THE PREMISES

- A. Contractor shall have use of the Project Site as shown on the applicable Drawings for execution of the Work of this Contract, except as may be otherwise indicated or necessitated by the requirements of the Project Manual, or as may be determined by the Owner.
- B. Contractor shall provide, or cause to be provided, and shall pay for all testing, labor, equipment, materials and such other utilities, transportation and facilities necessary for the proper execution of the Work, whether temporary or permanent, and whether or not incorporated or to be incorporated in the Work.
- C. Construction services shall be performed by qualified, licensed construction contractors and suppliers selected and paid by the Contractor.
- D. Contractor shall provide protection at all affected areas of the site during the performance of the Work.
- E. Contractor shall perform all work in conformance with O.S.H.A. requirements, which will be strictly enforced.
- F. Contractor shall coordinate the use of the premises consistent with the Project requirements as may be directed by the Owner.
- G. Contractor shall use access routes for delivery of materials and equipment only as indicated on the drawings approved by the Owner and as may be directed by the Owner. Do not use access routes other than those indicated. Contractor shall keep clean, maintain and repair all access routes used.
- H. Electrical power will not be provided for welding or any other equipment.
- I. Contractor shall assume full responsibility for the protection and safekeeping of all products under this contract, stored and / or installed on the Project Site as well as those products stored off the Project Site.

Materials, products and equipment shall be stored on the Project Site only in those areas indicated or allowed for staging and approved by the Owner.

- J. Safe staging and material storage shall be limited to the area indicated on the drawings, which have been approved by the Owner and as may be designated by the Owner. Contractor must obtain specific permission from the Owner for the use of other areas for storage and staging.
- K. Contractor shall protect existing sidewalks, pavement, curbs, utilities, building exterior and interior surfaces subject to damage by Work performed under this contract. Contractor shall, at his sole cost and expense, repair or replace any existing work damaged by his/her prime and/or sub-contractor's personnel or equipment.

1.03 WORK SEQUENCE AND COMPLETION

- A. Contractor shall work in an orderly manner coordinated with the work of other disciplines and trades.
- B. No disruption to, or use of adjacent facilities and access to those facilities will be allowed.
- C. The Owner may require certain work to be performed after normal working hours or on holidays or weekends or as may be necessitated in the Public interest. Such work does not constitute a change of scope or additional cost.
- D. Contractor shall perform the Work in conformance with the Summary Schedule and Key Milestones in Section 00750. This Section includes critical interim completion dates that the Contractor is required to meet.

1.04 LIQUIDATED DAMAGES

The Contractor agrees to commence Work under this Contract on the effective date established as "Notice to Proceed", and to complete the Work in conformance with the established Summary Schedule and Key Milestones in Section 00750 of the Project Manual. Should the Contractor neglect, fail or refuse to complete the Work by any one of the key milestone activities by its critical interim completion date(s) or the Substantial Completion date then the Contractor shall pay to the Owner Liquidated Damages in the amount of **\$500.00** per calendar day for those damages suffered by the Owner as a result of delay for each and every calendar day that the Contractor has failed to complete any key milestone activity by its interim completion date or the Substantial Completion date. The aforementioned Liquidated Damages are not a penalty, but rather are a pre-agreed liquidation of the losses incurred by the Owner due to failure of the Contractor to complete the Work on time.

1.05 SUBSTITUTIONS AND PRODUCT OPTIONS

Refer to Division I, Section 01600, Product Requirements in the Project Manual.

1.06 SURVEY

Contractor shall verify all survey data, Geotechnical reports and Dilatometer investigations included within the Contract Documents and report any errors and inconsistencies in writing to the Owner before any work is performed in those areas where errors and inconsistencies may exist. Refer to Division 1, Section 01310, Project Management and Coordination in the Project Manual.

PART 2- PRODUCTS

Not Used

PART 3- EXECUTION

Not Used

END OF SECTION 01100

SECTION 01290

PAYMENT PROCEDURES

PART 1 - GENERAL

1.1 RELATED REQUIREMENTS

- A. Division 0, Bidding and Contract Documents of the Project Manual.
- B. Division 1, General Requirements of the Project Manual

1.2 SUMMARY

- A. This Section specifies administrative and procedural requirements governing the Contractor's Certified Applications for Payment.
- B. This Section requires the coordination of the Contractor's Applications for Payment with the Construction Schedule, including established Key-Milestone Dates, Schedule of Values, Submittal Schedule, Prime and Sub-Contractors work.

1.3 APPLICATION FOR PAYMENT

A. General

1. Progress payments shall be applied for and made as the construction of the Work proceeds at intervals stated in the Contract. The Contractor will provide, to the Owner a "draft" copy of his/her Application for Payment on the 25th day of the month, or the closest workday should the 25th day fall on a weekend or holiday. This provides an opportunity to discuss figures (Schedule of Values) before they become "fixed", and will expedite the processing of the final typed Application when the Owner receives it.
2. Formal Applications for Payment shall be submitted to the Owner by close of business on the 1st day of the succeeding month, or the closest work day should the 1st day fall on a weekend or holiday of the month. The Certified Application for Payment will be processed, by the Owner, thirty (30) calendar days from the day that the Contractor submits the final Application for Payment, except if that day should fall on a weekend or holiday in which case payment shall be made on the next succeeding work day.
3. All information required on the Application shall be provided and filled in, including that for Change Orders executed prior to the date of submittal of the Application. Summary of dollar values must agree with respective totals indicated on continuation sheets.
4. Each Certified Application for Payment shall be consistent with previous Applications as approved by and paid for by the Owner.
5. All Work covered by Progress Payments shall, at the time of payment, become the property of the Owner.
6. Form of Application for Payment will be AIA Document G 702 revised, and Continuation Sheets G 703.
7. All formal Applications for Payment shall be submitted in duplicate to the Owner by means ensuring receipt within twenty-four (24) hours. Itemized Applications and supporting documents shall be submitted with a complete transmittal form listing attachments, and recording appropriate information related to the Application in a manner acceptable to the Owner. Itemized data and format

provided on continuation sheets shall include schedules, line items, values as stipulated in the Schedule of Values as accepted by the Owner.

8. With each Application for Payment the Contractor shall certify that such Application for Payment represents a just estimate of costs reimbursable to Contractor under terms of the Contract and shall certify there are no Mechanic's or Materialmen's Liens outstanding at the date of that Application for Payment, that all due and payable bills with respect to the Work have been paid to date or shall be paid from the proceeds of that Application for Payment, that there is no known basis for the filing of any Mechanic's or Materialmen's Lien against the Surety in connection with the Work, that Waivers and Bills Paid Affidavit forms from all prime and subcontractors, consultants and materialmen have been, or will be, obtained in the form agreeable to the Owner and that amount of the contract remaining to be expended is sufficient to complete the project.
9. The Contractor shall complete each entry on the forms, including notarization and execution by a person authorized to sign legal documents on behalf of the Contractor. Incomplete Applications for Payment will be returned without action.
10. Conditions governing regular schedule for applications, payment and retainage shall be as stated in the Contract.
11. Continuation sheets shall include a total list of all scheduled component items of work with item number and scheduled dollar value for each item. Dollar values to be included in each column for each scheduled line item when Work has been performed or products stored. Round off values to nearest dollar or as may be specified for Schedule of Values.
12. List each Change Order executed prior to date of submission at end of continuation sheets. List by Change Order number and description as to original component item of Work.

B. Waivers and Mechanics Liens

1. Monthly Applications for Payment shall include Waivers of Mechanic's Liens and Claims for all Work included in the period of construction covered by the Application for Payment and the previous month's Application. Waivers of Liens and Claims from prime contractors or subcontractors and suppliers shall include the period of construction covered by the Application for Payment, the total amount paid prior to and including the previous month's Application
2. Partial Waivers of Liens shall be submitted on each item of work for the amount requested, prior to deduction for retainage, for each item.
3. Contractor shall submit final or full Waivers of Liens and Claims for completed items of work shown on the monthly Application for Payment.
4. The Owner reserves the right to designate which entities involved in the Work must submit Waivers of Liens.
5. The Contractor's final Application for Payment shall be submitted with, or preceded by final Waivers from every entity involved with the performance of work, supplying of materials or the providing of professional services covered by the Application who could lawfully be entitled to a Lien.
6. Waivers of Liens shall be provided on forms, and executed in a manner acceptable to the Owner.

C. Initial (First) Monthly Application for Payment

1. Administrative actions and submittals that must precede or coincide with submittal of first Application for Payment include, but are not limited to the following:
 - a. List of all prime contractors, first and second tier subcontractors.
 - b. Contractor's Sworn Statement of principal suppliers, fabricators, prime and subcontractors.
 - c. Schedule of Values.
 - d. Contractor's construction schedule, to be updated monthly.
 - e. Schedule of principal products and long lead delivery items, to be updated monthly.
 - f. Submittal Schedule, Procurement Schedule.
 - g. Copies of all required permits.
 - h. Copies of authorizations and licenses from governing authorities for performance of work.
 - i. Initial progress report.
 - j. Certificates of Insurance and insurance policies.
 - k. Any material stored off site must carry additional insurance (All Risk Rider) stating Owner as insured. All material will be inspected by the Owner before billing can be approved. Bill of Sale and receipts for items being billed at cost only are required and 25% retainage will be held for off-site stored materials. Paperwork must accompany request two weeks prior to billing to insure adequate time to schedule Owner's inspection.
 - l. Contractor's Construction Safety Plan (Initial Only).

D. Application for Payment at Substantial Completion

1. The Contractor shall, upon issuance of the Certificate of Substantial Completion, submit his/her Application for payment, which shall reflect any Certificates of Substantial Completion issued previously for Owner occupancy for designated portions of the Work.
2. Application shall include, but not be limited to and as may be determined by the Owner, the following:
 - a. Certificates of Occupancy and such other permits and approvals as may be required.
 - b. Warranties (Guarantees) and maintenance agreements as may be applicable.
 - c. Testing, adjusting and balance records.
 - d. Maintenance manuals, training and instructions.
 - e. Equipment start-up performance reports.
 - f. Changeover information related to Owner's occupancy, use, operation and maintenance.
 - g. Final cleaning of the entire project site..
 - h. Application for Reduction of Retainage, and Consent of Surety.
 - i. List of incomplete Work, recognized as exceptions to issuance of Certificate of Substantial Completion.

E. Final Application for Payment

1. Administrative actions and submittals that shall precede or coincide with this final Application for Payment shall include, but not be limited to and as may be determined by the Owner, the following:
 - a. Completion of Project Closeout requirements.
 - b. Completion of items specified for completion after Substantial Completion.
 - c. Prepare and submit to the Owner a list of unsettled claims, as may be applicable.
 - d. Transmit to the Owner all required project records including permit drawings, as constructed drawings both on hard copy and in electronic (PDF) format.
 - e. Provide to the Owner evidence that all requisite taxes, fees and similar obligations have been paid in full.
 - f. Removal of all temporary facilities and services.
 - g. Removal of all surplus materials, rubbish and similar elements.

PART 2 - PRODUCTS

Not Used

PART 3 – EXECUTION

Not Used

END OF SECTION 01290

[REMAINDER OF PAGE INTENTIONALLY LEFT BLANK]

SECTION 01300

REGULATORY REQUIREMENTS

PART 1 – GENERAL

1.01 RELATED REQUIREMENTS

- A. Division 0, Bidding and Contract Documents of the Project Manual
- B. Division 1, General Requirements of the Project Manual

1.02 CODES, AUTHORITIES, REGULATORY AGENCIES, AND INDUSTRY REFERENCES

- A. Where references are made on the Drawings or in the Technical Specifications to codes, they shall be considered an integral part of the Contract Documents as minimum standards. Nothing contained in the Contract Documents shall be so construed as to be in conflict with any law, bylaw or regulation of the municipal, state, federal or other authorities having jurisdiction.
- B. Perform Work in compliance with the following code:
 - 1. Current edition of all applicable building code(s), local, state and federal.
- C. Perform Work in compliance with the following Authorities and Regulatory Agencies:
 - 1. Georgetown County, South Carolina
 - 2. South Carolina Dept. of Natural Resources (SCDNR)
 - 3. South Carolina Dept. of Transportation (SCDOT)
 - 4. South Carolina Department of Health Environmental Controls (SCDHEC/OCRM)
 - 5. OSHA Code of Federal Regulations. (OSHA)
 - 6. All federal, state and local clean air, clean water, water rights, resource recovery, and solid waste disposal standards and the Federal Endangered Species Act, and the Occupational Safety and Health Acts.
 - 7. Environmental Protection Agency (EPA).
- D. Perform Work in compliance with the following industry references:
 - 1. National Fire Protection Association (NFPA), National Electric Code (NEC).
 - 2. NFPA 101, Life Safety Code.
 - 3. SCE 7-88: Minimum Design Loads for Buildings and Other Structures.
 - 4. American Society for Testing and Materials (ASTM).
 - 5. Underwriters Laboratories (UL).
 - 6. The National Board of Fire Underwriters.

1.03 FIRE RATINGS

- A. Where material, component, or assembly is required to be fire rated, fire rating shall be determined or listed by the following testing agency:
 - 1. Factory Mutual Laboratories (FM).
- B. Equivalent fire rating as determined or listed by another testing authority is acceptable if approved by applicable governing authorities having jurisdiction in and for Georgetown County, South Carolina.

1.04 PERMITTING

- A. At no additional expense to the Owner, file for and obtain necessary licenses and permits for any interim phases for construction, and be responsible for complying with any Federal, State, County, and Municipal Laws, Codes, regulations applicable to the performance of the Work, including, but not limited to, any laws or regulations requiring the use of licensed prime and /or subcontractors to perform parts of the Work.

1.05 INSPECTION AND CERTIFICATIONS

- A. Arrange inspection and obtain Certificates of approval from applicable authorities having jurisdiction. Furnish Certificates of Approval in accordance with the applicable Technical Specifications and the General Requirements of the Contract.
- B. Notify and coordinate for all appropriate Georgetown County and State inspections of the work. Allow enough time to maintain progress of the work.

1.06 PERFORMANCE

- A. Should the Contractor knowingly perform any Work that does not conform with the requirements of applicable codes, ordinances, regulations, or standards, without given prior written notice to the Owner and obtaining required variance, etc. from the governing body, Contractor shall assume full responsibility thereof and shall bear all costs involved in correcting such non-complying Work. Costs shall include but not be limited to: All fines, inspection costs, damages, design and management fees in addition to the cost of removal and replacement of the work of all trades involved.

PART 2 – PRODUCTS

Not Used.

PART 3 – EXECUTION

Not Used.

END OF SECTION 01300

[REMAINDER OF PAGE INTENTIONALLY LEFT BLANK]

SECTION 01310

PROJECT MANAGEMENT AND COORDINATION

PART 1 – GENERAL

1.01 REQUIREMENTS INCLUDED

- A. The Contractor shall comply with and be responsible for all of the requirements of the Project Manual and the Construction Contract Documents, without exception
- B. The Contractor shall be responsible for general project coordination of all construction phases and aspects, trades and disciplines of the Work of the Project.
- C. The Contractor shall be responsible for general coordination of all construction site operations with other improvement projects that may be conducted by the Owner.
- D. The Contractor shall be responsible for general coordination with other interested parties including, but not limited to, DAVIS & FLOYD, Owner, other Contractors working on Owner or abutter property projects, and all involved permitting authorities.

1.02 RELATED REQUIREMENTS

- A. Division 0, Bidding and Contract Documents in the Project Manual.
- B. Division 1, General Requirements in the Project Manual

1.03 GENERAL COORDINATION

- A. Coordinate scheduling, submittals, and work of various Sections of the Technical Specifications to assure efficient and orderly sequence of installation of construction elements with provisions for accommodating items furnished by the Owner, or others, to be installed by the Contractor.
- B. Coordinate sequence of Work to accommodate partial occupancy for the Owner as specified in Section 01100, Summary of Work and / or as directed by the Owner.
- C. Review and coordinate requirements of all Divisions of the Project Manual and Sections of the Technical Specifications. Report any discrepancies to the Owner
- D. Maintain services of prime and major sub-contractors throughout duration of the Contract, except as may be required by provisions of Conditions of Contract. Notify the Owner, in writing, of intention to replace prime or sub-contractor(s), outlining reasons for the action and naming proposed replacement contractor(s).
- E. Coordinate work of prime and sub-contractors and record contractor installation(s) data on Project Record Drawings.
- F. All communications regarding Contract requirements shall be addressed to the Owner. Outline any special procedures required for coordination and include such items as required notices, reports and attendance at meetings.
- G. Arbitrate and resolve coordination conflicts between prime and sub-contractors to ensure complete and operational systems.

- H. Coordinate work with all existing utility systems.
- I. Coordinate construction activities to ensure that operations are carried out with due consideration given to energy, water and materials.
- J. Salvage materials and equipment involved in performance of, but not actually incorporated in, the Work.

1.04 COORDINATION MEETINGS

- A. In addition to the meetings referred to in Section 01315, Progress Meetings, the Contractor shall conduct coordination meetings and pre-installation meetings with supervisory personnel, prime and sub-contractors, suppliers, the Owner and others as necessary and applicable to assure coordination of different trades and disciplines
- B. Schedule coordination and pre-installation meetings with prime and sub-contractors, suppliers and the Owner to discuss hardware installation and specialty systems installation as may be applicable.

1.05 COORDINATION OF SUBMITTALS

- A. Coordinate use of Project space and sequence of installation of equipment, walks, parking areas, mechanical, electrical, plumbing, or other Work that is indicated diagrammatically on the Drawings and/or contained in the Technical Specifications. Utilize space efficiently to maximize accessibility for Owner installations, maintenance and repairs.
- B. In finished areas, except as otherwise shown, conceal ducts, pipes, wiring, and other non-finish items within construction. Coordinate locations of concealed items with finish elements, and provide as-constructed drawings of the involved location.
- C. Where installation of one part of the Work is dependent on installation of other components, either before or after its own installation, schedule construction activities in sequence required to obtain best results.
- D. Make adequate provisions to accommodate items scheduled for later installation, including accepted Bid Alternates, Owner supplied items, sub-subcontractor installed items, work by others, and installation of products purchased with allowances.

1.06 COORDINATION OF MECHANICAL, ELECTRICAL, AND OTHER INSTALLATIONS

- A. General: Sequence, coordinate, and integrate the various elements of mechanical, electrical, and other systems, materials, and equipment. Comply with the following requirements:
 - 1. Coordinate mechanical and electrical systems, equipment and materials installation with other building components.
 - 2. Verify all dimensions by field measurements, and advise the Owner of any dimensional conflicts.
 - 3. Arrange and coordinate for chases, slots, and openings in other building components during progress of construction.

4. Coordinate the installation of required supporting devices and sleeves to be set in poured-in-place concrete and other structural components, prior to placement of concrete and/or other structural components.
5. Where mounting heights are not detailed or dimensioned, install systems, materials, and equipment to provide the maximum headroom possible and advise the Owner prior to completion of such installations.
6. Coordinate connection of systems with exterior underground and overhead utilities and services. Comply with requirements of governing regulations, franchise service (utility) companies, and controlling agencies. Coordinate and provide required connection for each service.
7. Install systems, materials, and equipment to conform with approved submittal data, include coordination drawings. Confirm to arrangements indicated by the Contract Documents, recognizing that portions of the Work may be shown only in diagrammatic form. Where coordination requirements conflict with individual system requirements, immediately refer conflict to the Owner
8. Install systems, materials, and equipment level and plumb, parallel and perpendicular to other building systems and components. Elements restricting such installation will be referred to the Owner
9. Install systems, materials, and equipment to facilitate servicing, maintenance, and repair or replacement of disconnecting, with minimum of interference with other locations and ease of access.

PART 2 – PRODUCTS
Not Used

PART 3 – EXECUTION
Not Used.

END OF SECTION 01310

[REMAINDER OF PAGE INTENTIONALLY LEFT BLANK]

SECTION 01315

PROGRESS MEETINGS

PART 1 - GENERAL

1.1 RELATED DOCUMENTS

- A. Division 0, Bidding and Contract Documents apply to this Section.
- B. Division 1, General Requirements of the Contract Documents apply to this Section.

1.2 SUMMARY

- . This Section specifies administrative and procedural requirements for all project meetings including but not limited to the following:
 - 1. Field / Site Coordination Meetings.
 - 2. Construction Progress Meetings.
 - 3. Project Coordination / Information Response Meetings (By Owner)

1.3 PROGRESS MEETINGS

- A. Conduct Field / Site Work Coordination meetings at a location and at appropriate times to be determined by the Owner. Notify the Owner no less than 48 hours prior to scheduled meeting date.

Conduct Construction Progress meetings at the Project site, or at such location designated by the Owner at regularly scheduled intervals. At the onset of the project these meeting shall be held on a weekly basis until such time as the frequency is changed by the Owner. Notify the Owner of scheduled meeting dates. Coordinate dates of meetings with preparation of the payment request.

Conduct Project Coordination / Information Response Meetings at such times as may be required and at a location to be approved by the Owner. Notify the Owner no less than 48 hours prior to scheduled meeting date.

- B. Agenda: Agendas and minutes for Field and Project Coordination meetings will be prepared by whoever (Contractor or Owner) requests the meeting. Agenda for regularly scheduled Construction Progress Meetings will be prepared by the Owner; minutes of those meetings will be prepared by the Contractor.. Review and provide comment on minutes of the previous (Field/Site Coordination, Progress or Project Coordination meetings. Review other items of significance that could affect progress. Include topics for discussion as appropriate in the current status of the Project.
 - 1. Contractor's construction schedule: Review progress since the last meeting. Determine where each activity is in relation to the construction progress schedule, whether on time or ahead or behind schedule. Determine how schedule can be improved if behind.
- C. Reporting: After each Construction Progress meeting date the Contractor will prepare and forward to the Owner, minutes of the meeting for review and comment. The Owner will distribute (corrected) copies of minutes of the meeting to each party present and to other parties who should have been present. Contractor shall include a brief summary, in narrative form, of progress since the previous meeting and report.

1. Schedule Updating: Contractor will revise / update the construction schedule after each Construction Progress Meeting where revisions to the schedule have been made or recognized. Contractor will Issue the revised schedule, to the Owner, concurrently with the report / minutes of each meeting.

PART 2 – PRODUCTS (Not Applicable)

PART 3 - EXECUTION (Not Applicable)

END OF SECTION 01315

[REMAINDER OF PAGE INTENTIONALLY LEFT BLANK]

SECTION 01320

CONSTRUCTION PROGRESS AND DOCUMENTATION

PART 1 - GENERAL

1.01 REQUIREMENTS INCLUDED

- A. Schedule for Submittals
- B. Scheduling Personnel (NIC)
- C. Contract Milestones
- D. Submittal Schedule.
- E. Material Procurement Schedule.
- F. Construction Activities Schedule
- G. Construction Activities Schedule Revisions and Updates.
- H. Short Interval Schedule.
- I. Adjustments of Time for Completion.

1.02 RELATED REQUIREMENTS

- A. Division 0, Bidding and Contract Documents in the Project Manual, more specifically Section 00750, Summary Schedule and Key Milestones apply to this Section.
- B. Division 1, General Requirements in the Project Manual, more specifically Section 01100, Summary of Work, Section 01330, Submittal Procedures and Section 01770, Close Out Procedures apply to this Section.

1.03 SCHEDULING PERSONNEL

Not Included (NIC)

1.04 CONTRACT MILESTONES

- A. Key Milestones developed by the Owner and provided for in Division 0, Section 00750, Summary Schedule and Key Milestones in the Project Manual, are to be incorporated into the Contractor's Construction Schedule.
- B. Key Milestones: Key Contract Milestones (the "Milestones") are significant interim dates on the Critical Path of the Work and within the Contract Time at which certain portions of the Work must be either partially or totally complete in order for the Work to be in compliance with the Contract Documents
- C. Identify all Milestones in the Schedule Submittals, whether or not the Owner has identified those dates in the Bidding and Contract Documents.
- D. Milestones will be clearly identified in all Contractor submitted schedules and will serve as an essential instrument of measurement, by the Owner, of the Contractor's compliance with the Contract Documents.
- E. Failure by the Contractor to achieve Milestones by the Contract Dates may result in Owner implementing contractual remedies, as required, in order to regain the Contract Schedule.

1.05 SCHEDULE FOR SUBMITTALS

- A. Allow ten (10) calendar days for review and turnaround of any submittals as may be required in the Drawings and / or Technical Specifications. All required Submittals shall be forwarded directly to the Architect / Engineer of record with sufficient time to allow for review, approval, fabrication and delivery to support the Schedule as outlined. Copy of the transmittal only must be sent to the Owner.
- B. Incorporate all submittals required by the Contract Documents for the duration of the Contract Time
- C. Integrate the Submittal Schedule into the Contract Schedule and link material and equipment deliveries as appropriate to construction work activities.
- D. Indicate changes from the previous report with an asterisk.
- E. The Contractor shall submit the following as may be appropriate and acceptable to the Owner:
 - 1. Schedule of Submittals and Product Data: To be submitted within ten (10) calendar days from Notice to Proceed (NTP). Schedule shall show submittals commencing within ten (10) calendar days from NTP and completing within sixty (60) calendar days from NTP.
 - 2. Material Procurement Schedule: To be submitted within ten (10) calendar days from NTP.
 - 3. Construction Activities Schedule: To be submitted within ten (10) calendar days from NTP.
 - 4. Short Interval Schedule: To be submitted within seven (7) calendar days from NTP.
 - 5. Inspection and Material Testing Schedule: To be submitted within twenty-one (21) calendar days from NTP.
 - 6. Hot Laid Asphalt and Portland Cement Concrete Pour Schedules: To be submitted no less than five (5) calendar days prior to the date scheduled for the activity.

1.06 MATERIAL PROCUREMENT SCHEDULE

- A. Within ten (10) calendar days after the NTP, develop and submit a Material Procurement Schedule on a form acceptable to the Owner. At a minimum, the Submittal Schedule shall be in the form of (i) a hard copy and (ii) an electronic version (PDF) to be approved by the Owner.
- B. Incorporate all material required by the Contract Documents for the duration of the Contract Time.
- C. Integrate the Material Procurement Schedule with the Schedule of Submittals and the Contract Schedule.
- D. Review the Material Procurement Schedule at the weekly scheduled Construction Progress Meeting.
- E. Submit status of the Material Procurement Schedule with the monthly Contract Schedule Status Submission.
- F. Indicate changes from the previous report with an asterisk.

1.07 CONSTRUCTION ACTIVITIES SCHEDULE

- A. Within ten (10) calendar days following NTP and prior to submission of the first Application for Payment, submit the Construction Activities Schedule (Project Schedule) both in (i) a hard copy and (ii) electronic version (PDF). The Project Schedule shall employ the Critical Path Method (CPM) and may utilize Microsoft Project or equal.
- B. Incorporate all Key Milestones as designated by the Owner in the Contract Documents, Division 0, Section 00750, as well as other Milestones the Contractor identifies as significant points in time.
- C. At a minimum, the Construction Activities Schedule (Project Schedule) shall include the following:
 - 1. A computer generated bar chart, based upon the CPM logic, organized by discipline and resource and sorted by early start, early finish.
 - 2. No work activity shall exceed fifteen (15) working days in duration, unless agreed upon by the Owner.
 - 3. Each activity shall be cost loaded to reflect the estimated value of performing the work. Activity cost shall consist of the sum of labor, materials, equipment, supervision and allocated overhead. The sum of all activity cost shall equal the Contract Sum.

4. All Milestones, submittal dates and completion dates for all shop drawing activities, material procurement, fabrication and delivery dates shall be in support of the Construction Activities Schedule. Anticipated types and durations of usage for major equipment, and any other scheduling data relevant to the Work shall be included. .
5. Activities required for Project Closeout shall include appropriate activities for obtaining Substantial Completion, Punch List, Punch Work, Final Inspections (including pre-inspections and system checkouts), Closeout Submittals (Certificates, Warranties, Manuals, Release of Liens, As-Constructed drawings etc.). Show Milestones for Substantial Completion, Temporary Certificate of Occupancy (where appropriate), Certificate of Occupancy, and Final Completion.
6. Weather conditions, such as high or low ambient temperatures, wind, and/or precipitation, can influence progress of the work shall be considered and allowed for in the planning and scheduling of work. This is to ensure completion of the work within the Contract time. Weather conditions shall be determined by an assessment of average historical climatic conditions based upon the preceding ten (10) year records published for the locality by the U.S. Weather Bureau Service. Weather must be unusually severe and beyond the 10 year average to even be considered as having impacted the Project Schedule.
7. The Project Schedule shall indicate holidays and any non-work days applicable to the schedule.

D. Joint Review, Revision, and Acceptance of the Construction Activities Schedule:

1. Within five (5) calendar days of receipt of Contractor's proposed Construction Activities Schedule (Project Schedule), the Owner and the Contractor shall meet for joint review of the Project Schedule to address corrections or adjustments needed. Any areas that conflict with timely completion of the Work of the Project shall be subject to revision by the Contractor at no cost to the Owner.
2. Within five (5) calendar days after joint review, the Contractor shall revise and resubmit the Project Schedule in accordance with agreements reached during review. Within five (5) calendar days of resubmission of the revised proposed Project Schedule, the Owner and Contractor shall again meet for joint review.
3. Any areas of the schedule still not in compliance shall be corrected and the Project Schedule resubmitted for acceptance within three (3) calendar days of the joint review.
4. If the Contractor fails to define any element of work, activity or logic, and the Owner's review does not detect this error or omission, such error or omission when discovered shall be corrected at the next monthly update without change to Contract Time, and at no cost to the Owner.
5. If the Owner questions Contractor's proposed logic, activity duration or cost, Contractor shall provide satisfactory revisions or adequate justification, within five (5) calendar days of receipt of written request. Any changes to the Project Schedule shall be at the Contractor's sole cost and expense.

E. The Project Schedule shall become the basis for tracking and measuring progress once the Owner has provided written acceptance of the Contractor's submittal. Acceptance of the Project Schedule by the Owner does not relieve Contractor of any responsibilities for the accuracy or feasibility of the schedule, or the Contractor's ability to meet Substantial Completion, Contract Completion and/or Key Milestones – Intermediate dates. Also, acceptance does not warrant, acknowledge or admit the reasonableness of logic, activity duration or cost loading of the Project Schedule.

1.08 CONSTRUCTION ACTIVITIES SCHEDULE REVISIONS AND UPDATES

- A. The Construction Activities Schedule (Project Schedule) shall be updated monthly to show progress and submitted for the Owner's review. The Contractor shall provide the updated Project Schedule with each payment application. This shall include two (2) schedule hard copies and reports along with one electronic version using Microsoft Project or equal software. Non-submittal of the update will be grounds to withhold the Application for Payment.
- B. Updating of the Project Schedule to reflect actual progress shall not be considered revisions to the Schedule. The accepted Project Schedule cannot be changed (revised) without review and acceptance, by the Owner of the Contractor's proposed change.
- C. After the monthly Schedule Update, if the Project Schedule no longer represents actual progress of the Work, Contractor shall revise the Project Schedule to properly reflect progress and resubmit to the Owner. Any costs determined as a product of the Schedule Update shall be borne solely by the Contractor
- D. If Contractor desires to make changes in the Project Schedule to reflect revisions in method(s) of operating and scheduling of Work, Contractor shall notify the Owner in writing, stating the reason for the proposed revision. After the Owner accepts the proposed revision, the Contractor shall implement the revision within three (3) calendar days and submit the Project Schedule to the Owner for review and final approval. Any costs determined as a product of the Project Schedule changes shall be borne solely by the Contractor
- E. In addition, revisions to the Project Schedule that are requested by the Owner shall be made by the Contractor within three (3) calendar days of the requested revision.
- F. All revisions to the Project Schedule shall be identified by an appropriate activity code. The Contractor shall submit the proposed code structure to the Owner for approval. Approval of the codes and requested revision(s) are required prior to revising the accepted Project Schedule.
- G. If the Contractor defaults by failing to submit a Project Schedule, or provide the required updates or revisions, the Owner reserves the right to prepare the Project Schedule, update, or revision back-charging the Contractor for the cost of this work. In such an event:
 - 1. The Owner will request the Contractor's participation in the development of the Project Schedule, update or revision to assure the Project Schedule produced accurately reflects Contract requirements and progress of the Work. The Contractor shall respond and participate in this effort within three (3) calendar days of the Owners request.
 - 2. If the Contractor refuses to participate or cooperate with the Owner, then the Owner will develop the status of the Project Schedule to the best of its ability with the information available.
 - 3. Whether the Contractor participates or not, the Project Schedule shall be issued for the use of a unilateral Change Order to the Contract as may be appropriate and determined by the Owner.

1.09 SHORT INTERVAL SCHEDULE

- A. Within seven (7) calendar days from receipt of Notice to Proceed (NTP) the Contractor shall submit to the Owner a Short Interval Schedule.
- B. The Short Interval Schedule shall be a time-scaled, hand-drawn or computer generated schedule and be consistent with the timing and sequencing of the Construction Activities Schedule (Project Schedule). It is not required to be in a CPM format.
- C. The Short Interval Schedule shall depict all activities planned to occur within the next four (4) weeks from the data date and show status for activities, which have occurred within the prior one (1) week from the data date.
 - 1. Generally, no activity presented in the Short Interval Schedule shall have a duration greater than five (5) working days.

2. The Owner, from time to time, may require the Contractor to further define activities on the Short Interval Schedule that have a duration greater than one (1) day.
- D. The Contractor shall update the Short Interval Schedule at a minimum of once a week for the duration of the project. It shall be submitted to the Owner at regularly scheduled Progress and Coordination meetings. The data date shall be within one (1) workday of the aforesaid meeting.
- E. The Short Interval Schedule shall be utilized with Contractor's prime and sub-contractors and other project parties for the near term coordination of the Work.
- F. All Milestones identified in the Contract and scheduled to take place within the calendar time frame of the Short Interval Schedule shall be included in the Schedule.

1.10 ADJUSTMENT OF TIME FOR COMPLETION

- A. Time for Completion will be adjusted only in accordance with this Clause and the Contract Documents.
- B. Any request for adjustment of time for completion because of changes or alleged delays shall be accompanied by a complete and User Fee Comprehensive **Time Impact Analysis Proposal**, which shall be submitted for approval within five (5) calendar days of the event causing delay. Failure to provide the proper notice within this time frame shall be construed as the Contractor's acceptance that the event causing delay can be absorbed into the Construction Activities Schedule (Project Schedule) without causing a delay to the project completion or any Key Contract milestone date.
- C. Each **Time Impact Analysis Proposal** shall provide information justifying the request and stating the extent of the adjustment requested. Each Analysis shall be in a form and content acceptable to the Owner and shall include, but not be limited to, the general information set forth in this section appropriate to the type of request (change or alleged delay) including the following:
 1. A fragnet (a detailed sub-level schedule) CPM Schedule illustrating how Contractor proposes to have the change or alleged delay incorporated into the current Updated Project Schedule.
 2. Identification of activities in current updated Project Schedule, which are proposed to be amended due to the change or alleged delay, together with engineering estimates and other appropriate data justifying the proposal.
 3. **Time Impact Analysis Proposals** shall be based upon the dates when the change or changes were issued, or dates when alleged delay or delays began, status of work at that time, and shall include time computations for affected activities.
 4. Activity delays shall not automatically mean that an extension of the Contract Time is warranted or due to the Contractor. *It is the Owner's intention to own and control all float time indicated in the Project CPM Schedule.*
 5. Contract Time Extensions or Key Contract Milestone Adjustments will only be considered when a Critical Path activity or activities are affected and a resulting delay extends the Contract Completion Date or Key Contract Milestone date(s).
 6. Adjustment of a Key Contract Milestone date(s) may not necessarily result in an adjustment to the Contract Completion Date.
 7. As an alternative to extending the Contract Completion Date or adjusting Key Contract Milestones, the Owner may require the Contractor to adjust the Project Schedule. This shall be accomplished by revising logic, adding resources, working crews on overtime, working additional shifts, and any other mitigating measures that the Owner determines is in the best interest of the project and the Public. Contractor agrees to fully cooperate with the Owner in finding the most effective (least cost) means to accomplish this task when requested.
 8. Should the Owner find, after review of the **Time Impact Analysis**, that the Contractor is entitled to an extension of time for completion, the time extension for completion will be considered for approval by the Owner.
 9. **Time Impact Analysis** related to Change Order Work and/or Contract Time Extensions shall be incorporated into and attached to the applicable Change Order to be prepared by the Owner.

PART 2 – PRODUCTS

Not Used

PART 3 – EXECUTION

Not Used

END OF SECTION 01320

[REMAINDER OF PAGE INTENTIONALLY LEFT BLANK]

SECTION 01330

SUBMITTAL PROCEDURES

PART 1 – GENERAL

1.01 REQUIREMENTS INCLUDED

- A. Submit shop drawings, product data, samples, coordination drawings and certifications concurrently as required in the applicable Drawings and / or Technical Specifications.
- B. Prepare and submit to the Owner no later than ten (10) calendar days after receipt of Notice to Proceed (NTP), a list of submittals required by each applicable Section of the Technical Specifications. Submit in accordance with this Section and the requirements of Section 01310, Project Management and Coordination.
- C. Designate in schedule data dates for submission and review of shop drawings, product data and samples and the date of return.

1.02 RELATED REQUIREMENTS

- A. Division 1, General Requirements of the Project Manual.

1.03 SHOP DRAWINGS

- A. Present drawings in a clear and thorough manner. Prepare original, project specific documents- do not reproduce Construction Documents.
- B. Identify details by reference to sheet and detail, schedule or room numbers shown on Contract Drawings or as may be referred to in the Technical Specifications..
- C. Consecutively number shop drawings for each section of Work. Retain numbering system throughout all revisions.
- D. Show detail, material, dimensions, thickness, methods of assembly, attachments and relationship to adjoining Work and other pertinent data and details.
- E. Verify dimensions and field conditions. Clearly indicate field dimensions and field conditions.
- F. Check and coordinate shop drawings of any Section or trade with requirements of other Sections or trades as related and as required for proper and complete installation of Work.
- G. Prepare composite shop drawings and installation layouts when necessary or requested to depict proposed solutions for tight field conditions. Coordinate in field with affected trades for proper relationship to work of other trades based on field conditions.

1.04 PRODUCT DATA

- A. Preparation
 - 1. Annotate each sheet to clearly identify specific product or part installed, and specific data applicable to installation.

2. Show performance characteristics and capacities.
3. Show dimensions and clearances required.
4. Show wiring or piping diagrams and controls.
5. Indicate specified finish.
6. Indicate only those sheets, which are pertinent to specific product(s) with product clearly identified.

B. Manufacturer's standard schematic drawings and documents.

1. Modify drawings and diagrams to delete information which is not applicable to the Work.
2. Supplement standard information to provide information which is applicable to the Work.

1.05 SAMPLES

- A. Provide a minimum of two (2) samples, or as otherwise indicated in the Technical Specifications, of sufficient size to clearly illustrate:
1. Functional characteristics of the product, with integrally related parts and attachment devices.
 2. Full range of color, texture, and pattern.
 3. Samples shall be referenced to the applicable section of the Technical Specifications.

1.06 MANUFACTURER'S CERTIFICATION OF MATERIALS AND EQUIPMENT

- A. Before shop drawings or manufacturer's data for equipment are submitted for approval, a duly authorized manufacturer's representative of the proposed equipment shall review the design of the system relative to the proper operation of his/her equipment and material.
1. Shop drawings and/or manufacturer's data submitted shall include letter from manufacturer's representative certifying that his/her equipment and materials will operate and function satisfactorily under the proposed design conditions. If required by the jurisdiction having authority, data shall be signed and sealed by a South Carolina Registered Engineer in the respective discipline.
- B. Before the work is accepted, a duly authorized manufacturer's representative of the installed equipment shall inspect the installation and operation of his/her equipment and materials to determine that they are properly installed and properly operating in accordance with the manufacturer's recommendations.
- C. Systems requiring certification will be specified in each of the applicable Sections of the Technical Specifications.

1.07 CONTRACTOR REVIEW

- A. Contractor shall review all submittals prior to transmittal to the Architect / Engineer of record and the Owner.
1. The Contractor shall consecutively number all shop drawings and product data transmittals. Re-submittals would have the same number of the previous submittal followed by the suffix "A, B, C etc."
 2. The transmittal is to contain the Owner's RFP / Bid number and the applicable specification section for each product represented on the transmittal.
- B. Apply Contractor's stamp to submittals, initialed or signed by authorized person and dated, certifying: review of submittal, verification of products, field measurements and field construction criteria, and coordination of information within submittal with requirements of Work and the Construction Contract Documents.

- C Submittals without Contractor's stamp or submittals which, in the Owner's and the Architect / Engineer of record opinion are incomplete, contain numerous errors, or have not been checked or have only been checked superficially, will be returned without comments. Delays resulting therefrom shall be solely the Contractor's responsibility.
- D. Clearly note proposed deviations from the Contract Documents on submittals. Submit listing identifying deviations in a format acceptable to the Architect / Engineer of record and the Owner.
- E. Contractor shall be responsible to ensure quantities and dimensions shown on submittals comply with the requirements of the applicable Drawing and Technical Specifications.

1.08 SUBMISSION REQUIREMENTS

- A. Make submittals promptly to the Architect / Engineer of record and the Owner in accordance with approved Submittal and Project Progress Schedule and in such sequence as to cause no delay in the Work.

- B. Number of submittals required:

1. Shop Drawings: Submit two (2) full size, hard copies and one (1) electronic version (PDF) in addition to what the Contractor will require back; submit one (1) additional electronic version (PDF) each for civil, structural, mechanical, electrical or landscaping work.
2. Product Data: Submit two (2) originals that will be retained by the Architect / Engineer of record and the Owner.
3. Samples: Submit the number stated in each of the respective Technical Specifications, with a minimum of two (2) samples, or as otherwise noted in the applicable Technical Specifications, for each item.

- C. Submittals shall contain:

1. Date of submission and dates of any previous submissions.
2. Owner RFP / Bid number.
3. The names of:
 - a. Contractor.
 - b. Subcontractor.
 - c. Supplier.
 - d. Manufacturer.
4. Identification of the product, with the applicable Specification Section number.
5. Field dimensions, clearly identified as such.
6. Relation to adjacent or critical features of the Work or Materials.
7. Applicable standards, such as ASTM or Federal Specification numbers.
8. Identification of deviations from Contract Documents and justification.
9. Identifications of revisions on re-submittals.
10. Additional information as required by Contract Documents.
11. An 8 in. x 3 in. blank space for Contractor and Architect/Engineer stamps.

- D. Contractor's responsibility for deviations in submittals from requirements of Contract Documents is not relieved by the Architect / Engineer of record or Owner review of submittals

- E. Numbering system established by the Contractor and shall be agreeable to the Owner.

1.09 RESUBMISSION REQUIREMENTS

- A. Contractor will make any corrections or changes in the submittals required by the Architect / Engineer of record or the Owner, mark number of submission, and resubmit as required until approved; none of this shall be of any cost to the Owner.
- B. Shop Drawings and Product Data:
 - 1. Contractor will revise initial drawings and data, and resubmit as specified for the initial submittal.
 - 2. Contractor will indicate any changes which have been made other than those requested by the Architect / Engineer of record or the Owner.
 - 3. Mark number of submission and resubmit until accepted.
- C. Samples: Contractor will submit new samples as required for initial submittal. Remove samples, which are “rejected” or designated “resubmit.”

1.10 REVIEW RESPONSIBILITIES – ARCHITECT / ENGINEER OF RECORD (A/E)

- A. The A/E shall review submittals, when applicable, with responsible promptness in accordance with the requirements of the Project Manual.
- B. The A/E will affix stamp and initials or signature, and indicate requirements for revisions and re-submittal, if any.
- C. The A/E will return submittals to Contractor, with copy of transmittal to Owner, for distribution, or for resubmission within five (5) days of original receipt.

PART 2 – PRODUCTS

Not Used

PART 3 – EXECUTION

Not Used.

END OF SECTION 01330

[REMAINDER OF PAGE INTENTIONALLY LEFT BLANK]

SECTION 01331

SCHEDULE OF VALUES

PART 1 – GENERAL

1.01 RELATED REQUIREMENTS

- A. Contractor shall submit to the Owner a Schedule of Values with line items allocated to various portions of the Work for the purpose of monitoring the progress of the work and administration of the Application for Payment Process with their response (Bid) to the RFP.
- B. Provide Owner, after receipt of the Notice to Proceed (NTP) and upon request by the Owner, including support values and data substantiating their accuracy and correctness.
- C. Division 0, Bidding and Contract Documents in the Project Manual.
- D. Division 1, General Requirements in the Project Manual.

1.02 FORM AND CONTENT

- A. The Schedule of Values shall be tabulated to correspond with the Contractor's Application for Payment form, and shall be identified with:
 - 1. Title of Project, Location and Owner RFP or Bid Number.
 - 2. Project Manager for Contractor
 - 3. Name and Address of Contractor
 - 4. Contract Designation
 - 5. Date of Submission
- B. Schedule of Values shall be presented in accordance with the CSI format on a line item basis
- C. Listing of Component Items:
 - 1. Identify each line item with the number and title of the respective major section of the Technical Specifications.
 - 2. Provide breakdown of Contract Sum in sufficient detail to facilitate continued evaluation of Applications for Payment and Progress Reports. Break principal subcontract amounts down into several line items by completed task in various locations.
 - 3. Round off amounts to nearest whole dollar, total of all listed values shall equal total Contract Sum.
 - 4. For each part of the Work where an Application for Payment may include materials or equipment, purchased or fabricated and stored, but not yet installed, provide separate line items on Schedule of Values for initial cost of materials, for each subsequent state of completion, and for total installed value of that part of the Work.
 - 5. Costs of actual work-in-place may be shown as separate line items in Schedule of Values, such as:
 - a. Bonds
 - b. Insurance
 - c. Temporary facilities, services and controls.
 - d. Field supervision and layout
 - e. Testing
 - 6. Separate material cost and labor cost as directed or requested by the Owner
- D. For each major line item whose value is larger than five thousand dollars (\$5,000.00) list sub-values of major products or operations under the item.

E. For various portions of the Work:

1. Each item shall include a directly proportional amount of overhead and profit.
2. For items on which progress payments will be requested for stored materials, break down the value into:
 - a. Cost of materials, delivered and unloaded, with taxes paid.
 - b. Total installed value.

F. The sum of all values listed in the Schedule of Values must equal the total Contract Sum.

1.03 SUB-SCHEDULE OF UNIT MATERIAL VALUES

A. Not Included (NIC)

1.04 RESUBMITTAL

- A. After review by the Owner, the Contractor may be requested to revise and resubmit Schedule of Values as may be determined appropriate by the Owner.
- B. Revised and approved Schedule of Values shall be resubmitted as part of monthly Application for Payment.

1.05 MATERIALS STORED OFF - SITE

- A. Payment for materials and equipment stored off – site, and not on the property of Georgetown County shall be subject to, and comply with the following:
 1. Prior written approval from the Owner, of materials and equipment to be stored, and location of facilities to be used for storage.
 2. Storage of materials and equipment will be in a bonded warehouse. Proof of insurance shall be provided to the Owner in the name of Georgetown County.
 3. Contractor shall furnish an inventory, including invoices, for all stored materials and equipment that are included in the Application for Payment using a form acceptable to and approved by the Owner.
 4. Contractor shall issue a Bill of Sale to the Owner for all items.

PART 2 - PRODUCTS

Not Used

PART 3 – EXECUTION

Not Used

END OF SECTION 01331

[REMAINDER OF PAGE INTENTIONALLY LEFT BLANK]

SECTION 01400

QUALITY REQUIREMENTS

PART 1 - GENERAL

1.01 REQUIREMENTS INCLUDED

- A. Contractor's Quality Control (QC), in addition to customary testing and control requirements and those included in the Construction Contract Documents.
- B. Manufacturer's field services, coordinated by the Contractor.

1.02 RELATED REQUIREMENTS

- A. Division 0, Bidding and Contract Documents of the Project Manual.
- B. Division 1, General Requirements of the Project Manual.

1.03 GENERAL QUALITY CONTROL

- A. Maintain Quality Control over construction activities, suppliers, manufacturers, products, services, site conditions, and workmanship of all personnel to assure Work is of specified quality.
- B. Quality inspections:
 - 1. Contractor shall be the first line of quality control and shall review all items for compliance with the Drawings and Technical Specifications reviewed and approved by the Owner. Prior to the Contractor's Testing Laboratory inspectors performing Quality Assurance (QA) review and inspections such as rebar placement, asphalt and concrete, piling inspection, soil compaction, etc., the Contractor shall have verified conformance to the requirements of the Construction Contract Documents, plans and technical specification prepared by the Architect / Engineer of record and reviewed and approved by the Owner.
 - 2. Maintain a written Quality Assurance / Control Program establishing the methods of assuring compliance to the contract documents. The Program shall be submitted to, reviewed and approved by the Owner. Quality Control personnel shall be identified at the initiation of the Project and shall be adequate to monitor the Work effectively and to enforce the Quality Assurance / Control procedures.
 - 3. Inspect each phase of Work for compliance with Contract Documents, plans and specification prepared by the Architect / Engineer of record and reviewed and approved by the Owner.
 - 4. Contractor shall have defective conditions corrected before calling for inspections and starting subsequent operations which would cover or are dependant upon the Work in question.
 - 5. Where visual inspection is not sufficient, such as in verifying slope of pavement or depth of retention / detention ponds for proper drainage, use instruments with qualified operators to inspect work.
 - 6. Secure the services of a testing laboratory when necessary to assist in evaluating quality.

1.04 WORKMANSHIP

- A. Comply with industry standards, except when more restrictive tolerances or specified requirements are called for in Construction Contract Documents, plans and specifications prepared by the Architect / Engineer of record and reviewed and approved by the Owner.
- B. Perform work by persons qualified to produce workmanship of specified quality.
- C. Secure products in place with positive anchorage devices designed and sized to withstand stress, vibration and other forces such as, but not limited to hurricane force winds.

1.05 MANUFACTURER'S INSTRUCTIONS

- A. When required by the Technical Specifications, submit manufacturer's current printed instructions, in the quantity required for product data, for delivery, storage, assembly, installation, startup, adjusting and finishing, as necessary.
- B. Comply with instructions in full detail, including each step in sequence. Should instructions conflict with Construction Contract Documents, plans and technical specifications prepared by the Architect / Engineer of record and reviewed and approved by the Owner, Contractor shall re-submit and provide written clarification and explanation to the Architect / Engineer of record and the Owner.

1.06 MANUFACTURER'S CERTIFICATES

- A. When required by the Technical Specifications, supplier/manufacturer shall provide qualified personnel to observe field conditions, conditions of the surfaces and installation, quality of workmanship, start-up of equipment, testing, adjusting and balancing of equipment as applicable, and to make appropriate recommendations.

1.07 MANUFACTURER'S FIELD SERVICES

- A. When specified in the respective Technical Specification Sections, the supplier/manufacturer will provide qualified personnel to observe field conditions, conditions of the surfaces and installation, quality of workmanship, start-up of equipment, testing, adjusting and balancing of equipment as applicable, and to make appropriate recommendations.
- B. Manufacturer's Representative shall submit written report to Architect / Engineer of record and the Owner listing observations and recommendations.

1.08 CONTRACTOR'S CERTIFICATION

- A. Contractor shall supply written certification that the Work, as installed, has been reviewed by him/her for compliance with the Contract Documents, applicable Drawings and Technical Specifications.

PART 2 – PRODUCTS

Not Used

PART 3 – EXECUTION

Not Used

END OF SECTION 01400

[REMAINDER OF PAGE INTENTIONALLY LEFT BLANK]
SECTION 01410

TESTING LABORATORY SERVICES

PART 1 – GENERAL

1.01 REQUIREMENTS INCLUDED

- A. The Contractor shall employ and pay for the services of an Independent Testing Laboratory to perform specified testing of work and materials at the Project Site or at point of manufacture under the provided allowance. Contractor shall incorporate recommendations from testing results.
- B. The Contractor shall comply with and be responsible for all of the requirements of the Project Manual, without exception.

1.02 RELATED REQUIREMENTS

- A. Conditions of the Contract: Inspections and testing required by laws, ordinances, rules, regulations, orders, or approvals of public authorities.
- B. Each specification section listed: Inspection and laboratory testing required, and standards for testing.
- C. Division 1, General Requirements of the Project Manual.

1.03 QUALIFICATIONS OF LABORATORY

- A. Meet “Recommended Requirements for Independent Laboratory Qualification,” published by American Council of Independent Laboratories.
- B. Comply with the following requirements:
 - 1. ANSI/ASTM D3740: Practice for Evaluation of Agencies Engaged in Testing and/or Inspection of Soil and Rock as Used in Engineering Design and Construction.
 - 2. ANSI/ASTM E329: Standard Recommended Practice for Inspection and Testing for Concrete, Steel, and Bituminous Materials as Used in Construction.
- C. Authorized to operate in the State of South Carolina
- D. Submit copy of report of inspection of facilities made by Materials Reference Laboratory of National Bureau of Standards during the most recent tour of inspection, with memorandum of remedies of any deficiencies reported by the inspection.
- E. Testing Equipment:
 - 1. Calibrated at reasonable intervals by devices of accuracy traceable to either:
 - a. National Bureau of Standards.
 - b. Accepted values of natural physical constants.

1.04 LABORATORY DUTIES

- A. Cooperate with the Owner and Contractor; provide qualified personnel after due notice from Contractor.
- B. Perform specified inspections, sampling and testing of materials and methods of construction:
 - 1. Comply with specified standards.
 - 2. Ascertain compliance of materials with requirements of Contract Documents.
- C. Promptly notify Owner and Contractor of observed irregularities or deficiencies of work or products.
- D. Promptly submit written report of each test and inspection: one (1) copy each to Owner and Contractor. Each report shall include:
 - 1. Date issued.
 - 2. Project title and Bid Number
 - 3. Testing laboratory name, address and telephone number.
 - 4. Name and signature of laboratory inspector.
 - 5. Date and time of sampling or inspection.
 - 6. Record of temperature and weather conditions.
 - 7. Date of test.
 - 8. Identification of product.
 - 9. Location of sample or test in the Project.
 - 10. Type of inspection or test.
 - 11. Results of tests and compliance with Contract Documents.
 - 12. Interpretation of test results, when requested by Owner
- E. Perform additional tests as may be required.

1.05 LIMITATIONS OF AUTHORITY OF TESTING LABORATORY

- A. Laboratory is not authorized to:
 - 1. Release, revoke, alter or enlarge on requirements of Contract Documents.
 - 2. Approve or accept any portion of the Work.
 - 3. Perform any duties of the Contractor.
 - 4. Stop the Work.

1.06 CONTRACTOR'S RESPONSIBILITIES

- A. Cooperate, together with laboratory personnel, will provide access to the point/location of the Work, and to manufacturer's operations.
- B. Secure and deliver to laboratory at designated location(s) adequate quantities of representational material proposed to be used and which require testing together with applicable proposed design mixes.

- C. Provide to the laboratory the preliminary design mix proposed to be used for concrete, and other material mixes which required control by the testing laboratory.
- D. Furnish copies of Products test reports to the Owner as required.
- E. Furnish incidental labor and facilities:
 - 1. To provide access to Work to be tested.
 - 2. To obtain and handle samples at the Project Site or at the source of the product to be tested.
 - 3. To facilitate inspections and tests.
 - 4. For storage and curing of test samples.
- F. Notify laboratory twelve (12) hours in advance of operations to allow for laboratory assignment of personnel and scheduling of tests.
- G. Make arrangements with laboratory and pay for services to perform inspections, sampling and testing required.

1.07 SOURCE OF MATERIALS

- A. Source of supply of each of materials required shall be acceptable to the Owner and before delivery is started.
- B. Representative samples shall be submitted for inspection or tests.
- C. Results obtained from testing samples will be used for preliminary approval, but will not be used as final acceptance of materials.
- D. If it is found that sources of supply, which have been approved, do not furnish product of uniform quality, or if product from any source proves unacceptable at any time, Contractor shall furnish approved material from another source without additional cost to Owner or delay in completion date.

1.08 IDENTIFICATION

- A. Required samples submitted by Contractor shall be properly labeled for identification.
- B. Materials and/or equipment that have been inspected and/or tested shall be stored in a controlled area with suitable identification referencing tests and certifications.
- C. Continuous inventory shall be kept of all items in this area controlled by log in and log out with receiving and disbursing signatures.
- D. Copies of receiving or disbursing actions shall be sent to the Owner on a daily basis.
- E. Disbursing records shall show final destination and installation.

1.09 MATERIAL STORAGE

- A. Materials shall be stored so as to ensure preservation of their quality and fitness for Work, in accordance with requirements of Section 01620, Storage and Protection.

1.10 SCHEDULE OF INSPECTIONS AND TESTS

- A. Refer to each individual Section of the Project Manual for specific testing requirements, or as otherwise required by the Contract Documents or appropriate regulatory agency.

PART 2 – PRODUCTS

Not Used.

PART 3 – EXECUTION

Not Used.

END OF SECTION 01410

SECTION 01500

TEMPORARY FACILITIES AND UTILITIES

PART 1 – GENERAL

1.01 REQUIREMENTS INCLUDED

- A. The Contractor shall comply with and be responsible for all of the requirements of the Project Manual and the Construction Contract Documents.
- B. Furnish, install and maintain temporary utilities required for construction, to be removed at completion of Work.
- C. Provide and maintain methods, equipment, and temporary construction required to control environmental conditions at construction site and other areas under Contractor's control. Remove evidence of temporary facilities at completion of Work.
- D. Furnish and pay for installation of all temporary utilities, permanent utilities except as provided by Owner, or fuel required for testing of installed equipment and systems.

1.02 RELATED REQUIREMENTS

- A. Division 1, General Requirements of Project Manual.

1.03 REQUIREMENTS OF REGULATORY AGENCIES

- A. Comply with National Electric Code (NEC), federal, state, and local codes and regulations and with utility company requirements.
- B. Comply with State of South Carolina regulatory agencies having judicial authority.
- C. All affected Utility Organizations should be contacted by the Contractor to arrange temporary utilities. The appropriate Utility Organization, as well as other Contacts are listed on the cover sheet of the construction contract drawings.

PART 2 – PRODUCTS

2.01 MATERIALS, GENERAL

- A. Materials may be new or used, but must be adequate in capacity for the required usage, must not create unsafe conditions, and must not violate requirements of applicable codes and standards.

2.02 TEMPORARY ELECTRICITY AND LIGHTING

- A. Arrange with Santee Electric Cooperative.
- B. Contractor will pay all electrical consumption charges.

2.03 TEMPORARY HEAT AND VENTILATION

Not Used

2.04 TEMPORARY TELEPHONE SERVICE

Not Used

2.05 TEMPORARY WATER

- A. Arrange with Georgetown County Water & Sewer District for temporary service.
- B. Furnish and install temporary water line and distribution from a point designated by the Owner, if determined to be necessary.
- C. Contractor will pay all water consumption charges.

2.05 DRINKING WATER

- A. The Contractor shall furnish potable water for drinking of all personnel connected with the Work of this contract.
- B. Pipe or transport water to keep clean and fresh.
- C. Provide drinking water in suitable containers or dispensers and paper cups located in close proximity to where work is in progress.

2.06 TEMPORARY SANITARY FACILITIES

- A. Provide portable chemical-type sanitary facilities in compliance with applicable health laws, and state, county and local regulations and ordinances.
- B. Service, clean and maintain facilities and enclosures.
- C. Facilities shall be fitted with approved sanitary holding capacity and shall be emptied periodically to prevent overflow. Legal disposal of sanitary waste must be off-site and is Design/Builder's responsibility.
- D. Construction workers and project staff shall not use permanent plumbing facilities
- E. Sanitary facilities failing to meet required standards or maintenance methods shall be corrected immediately.
- F. Contractor will pay all costs for installation, maintenance and removal.

2.07 TEMPORARY FIRE PROTECTION

- A. During construction, provide temporary fire protection and life safety provisions in accordance with local jurisdiction requirements, the International Code and / or NFPA Standards.
- B. A "Hot Work" permit may be required when welding or cutting operations are to take place. Take necessary precautions in welding or cutting operations to keep work area free of combustible materials. Do not use welding equipment around flammable liquids or vapors.
- C. Keep welding and cutting equipment outdoors wherever possible. Remove welding and cutting equipment from any structure daily, wherever practical.

- D. At completion of welding or cutting operations, inspect work and adjacent area for hazards. When operations are near any building opening, inspect areas above, below or adjacent to work area hazards.
- E. Do not open, turn off, interfere with, attach any pipe or hose to, or connect anything to any fire hydrant, stop valves, or stop cock, or tap any water main without prior written permission of proper authority or the Owner.

PART 3 – EXECUTION

3.01 GENERAL

- A. Comply with local jurisdiction and all other applicable requirements as stated in this Section.
- B. Contractor shall obtain and pay for all required permits for the Work.

3.02 REMOVAL

- A. Completely remove from the project site temporary materials and equipment when their use is no longer required.
- B. Clean and repair damage caused by temporary installations or use of temporary facilities immediately after removal.
- C. Restore existing facilities used for temporary services to specified, or to original, condition.
- D. Restore permanent facilities used for temporary services to specified condition.

END OF SECTION 01500

SECTION 01510

TEMPORARY CONSTRUCTION CONTROLS

PART 1- GENERAL

1.01 REQUIREMENTS INCLUDED

- A. The Contractor shall comply with and be responsible for all of the requirements of the Project Manual, without exception.
- B. Furnish, install and maintain temporary controls required for construction.
- C. Remove all temporary controls at completion of Work.

1.02 RELATED REQUIREMENTS

- A. Division 1, General Requirements of the Project Manual.

1.03 CONSTRUCTION SITE CLEANING

- A. Maintain areas within limits of the Project Work Site free of extraneous debris and litter.
- B. Initiate and maintain specific program to prevent accumulation of debris at construction site, storage and parking areas, or along access roads and off site hauls routes.
 - 1. Furnish on-site containers for collection of waste materials, debris and rubbish.
 - 2. Prohibit overloading of trucks to prevent spillage on access and haul routes.
 - 3. Provide periodic inspection of traffic areas to enforce requirements.
 - 4. Remove waste material, debris and rubbish from site and building area daily, or sooner as otherwise needed.
 - 5. Do not drop or throw materials from heights. Lower waste material in a controlled manner and with as few handlings as possible.
 - 6. During entire construction period, and at all times, keep the site access entry road, parking areas free from accumulation of waste materials, debris and rubbish caused by the Work of this Project.
 - 7. Dirt and debris shall be removed from all surfaces prior to closure of all areas (walls, ceilings, chases, etc.).
- C. Hazards Control:
 - 1. Store volatile wastes in covered metal containers.
 - 2. Remove containers from premises daily.
 - 3. Prevent accumulation of wastes, which create hazardous conditions.
 - 4. Provide adequate ventilation during use of volatile or noxious substances.
- D. Conduct cleaning and disposal operations to comply with local ordinances and anti-pollution laws:
 - 1. Do not burn or bury rubbish and waste materials on project site.
 - 2. Do not dispose of wastes into streams or waterways.
 - 3. Do not dispose of volatile wastes such as mineral spirits, oil or paint thinner in storm or sanitary drains.

1.04 DUST CONTROL

- A. Provide positive methods and apply dust control materials to minimize raising dust from construction operations and provide positive means to prevent air-borne dust from dispersing into atmosphere.
- B. Clean interior building areas to prevent accumulation of dirt and debris and execute prior to start of finish painting, special coatings, and/or other finish material installations.
- C. Wet down materials and rubbish to prevent blowing dust.
- D. Schedule cleaning operations so that dust and other contaminants resulting from cleaning process will not fall on wet, newly painted surfaces.
- E. Continue cleaning on an as-needed basis until building and/or site is ready for beneficial occupancy.

1.05 EROSION AND SEDIMENT CONTROL

- A. Plan and execute construction and earthwork by methods to control surface drainage from cuts and fills, and from borrow and waste disposal areas, to prevent erosion and sedimentation. Wetland areas shall be protected as well.
 - 1. Hold areas of bare soil exposed at one time to minimum.
 - 2. Provide temporary control measures such as berms, dikes, and drains.
 - 3. Comply with federal, state and local regulations.
- B. Construct fills and soil waste areas by selective placement to eliminate surface soils or clay, which will erode.
- C. Periodically inspect earthwork to detect any evidence of start of erosion, apply corrective measures as required for erosion control.

1.06 POLLUTION CONTROL

- A. Provide methods, means and facilities required to prevent contamination of soil, water or atmosphere by discharge of noxious substances from construction operations.
- B. Contractor is responsible only for pollution control of the immediate Work of the Contract, the actions and operations of the Contractor, and the workers employed or contracted to Contractor. Provide equipment and personnel to perform emergency measures required to contain spillage, and to remove contaminated soil or liquids.
- C. Take special measures to prevent harmful substances from entering public waters. Prevent disposal of wastes, effluents, chemicals or other such substances adjacent to basins, or in sanitary or storm sewers.
- D. Provide systems for control of atmospheric pollutants. Prevent toxic concentrations of chemicals. Prevent harmful disposal of pollutants into atmosphere.

1.07 WATER CONTROL

- A. Provide methods to control surface water to prevent damage to project site or adjoining properties. Control fill, grading, and ditching to direct surface drainage away from excavations, pits, tunnels and other construction areas. Direct drainage to proper runoff.
- B. Provide, operate, and maintain hydraulic equipment of adequate capacity to control surface and water.
- C. Dispose of drainage water in manner to prevent flooding, erosion or other damage to any portion of site or adjoining areas.
- D. Dewater areas in accordance with applicable local and state requirements and accepted professional practice.

1.08 EARTH CONTROL

- A. Contractor shall, at his/her sole cost, remove excess soil, pier spoils, etc., at time of generation.

PART 2 – PRODUCTS

Not Used

PART 3 – EXECUTIONS

3.01 REMOVAL

- A. Contractor shall, at his/her sole cost, remove temporary construction controls at the completion of the Work, or as required by execution of the Work or as may be directed by the Owner..

END OF SECTION 01510

[REMAINDER OF PAGE INTENTIONALLY LEFT BLANK]

SECTION 01530

BARRIERS

PART 1 – GENERAL

1.01 REQUIREMENTS

- A. The Contractor shall comply with and be responsible for all the requirements of Division 1, General Requirements of the Project Manual, without exception.
- B. Provide and maintain barriers and lighted barriers for the protection of personnel and materials in accordance with the requirements of applicable state and local codes.
- C. Install barriers at the start of construction.

1.02 RELATED WORK

- A. Section 01510, Temporary Construction Controls

1.03 REGULATORY AGENCIES

- A. Comply with federal, state, and local, municipal regulations and with utility company and insurance agencies' requirements.

PART 2 – PRODUCTS

2.01 MATERIALS, GENERAL

- A. Materials and equipment must be adequate in capacity for the required usage, and not violate applicable codes and standards.
- B. Provide warning signs to help prevent damage and injury.
- C. Should it become necessary to remove safety items it shall be the Contractor's responsibility to replace the item immediately in conformance with applicable codes, standards and regulations.
- D. Wood materials used in barricades and barriers within any building and in material storage areas shall be fire-retardant.

2.02 BARRICADES

- A. Protect all vertical shafts with safe, temporary railings, adequately braced.
- B. Cover trenches and holes when not in use. Erect barriers at sharp changes in plane of more than 3 feet.
- C. Protect all building openings with safe, temporary railings adequately braced.

2.03 CONSTRUCTION FENCE

- A. Prior to starting work at Project Site the Contractor, as may be directed by the Owner, shall install enclosure fence with locked entrance gates.
- B. Provide construction fence around material storage and construction areas to prevent unauthorized access. Comply with local, municipal and / or Georgetown County requirements for construction barriers.
- C. Provide minimum number of gates, padlocked during non-working hours as may be directed by the Owner.
- D. Locate personnel gates as necessary to provide controlled entry from construction parking to construction area, as may be directed by the Owner.

2.04 PERIMETER SIGNAGE (NIC)

2.05 CONSTRUCTION LIGHTING

- A. Provide construction lighting throughout construction areas as may be required and necessary to maintain safety and security.
- B. Maintain lighting on a daily basis, including weekends, holidays, and foul-weather days so that the Project Site is adequately lighted at all times in the interest of safety and security.

PART 3 – EXECUTION

3.01 REMOVAL

- A. Contractor shall, at his/her sole cost, completely remove barricades, including barricades foundations when construction has progressed to a point that they are no longer required, and when requested by the Owner.

3.02 CLEANING

- A. Clean and repair damage caused by the Work of this Section. Fill and grade the areas of the Site to required elevations and slopes, and clean the area.

END OF SECTION 01530

[REMAINDER OF PAGE INTENTIONALLY LEFT BLANK]

SECTION 01550

ACCESS ROADS AND PARKING AREAS

PART 1 – GENERAL

1.01 REQUIREMENT INCLUDED

- A. The Contractor shall comply with and be responsible for all the requirements of Division 1, General Requirements of the Project Manual without exception.
- B. Access to and egress from the Project Site will be gained only via routes and through gates as approved by Owner. Equipment weight and height limits will be strictly enforced. Contractor is responsible for providing access roads capable of supporting construction traffic. Contractor and trade contractors of all tiers shall be responsible to comply with these requirements.
- C. Install barriers and necessary traffic controls at start of construction to protect public and leave in place throughout construction. Remove at end of construction.
- D. Contractor is responsible for assessing risk to public and providing lights, flagmen, traffic signals, stop signs or other necessary controls, as needed and approved by the Owner and / or the South Carolina Dept. of Transportation (SCDOT).
- E. Contractor shall be responsible to repair all damage to offsite street, roads, curbs along haul routes and any existing site elements damaged by construction related traffic.

1.02 RELATED WORK

- A. NIC

1.03 REGULATORY AGENCIES

- A. Comply with federal, state and local codes and regulations, and with utility company and insurance agencies' requirements.

PART 2 – PRODUCTS

2.01 GENERAL

- A. If repair to public or private roadways is necessary due to damage by construction traffic, materials and methods used for repairs are to be acceptable to the applicable jurisdictional authority and are to match existing conditions. Contractor shall perform such work at his/her sole cost and expense.
- B. Provide warning signs to help prevent damage and injury and to promote safety..
- C. Should it become necessary to remove safety items, it shall be Contractor's responsibility to replace them immediately, in conformance with applicable regulations. Contractor shall perform such work at his/her sole cost and expense.

2.02 PARKING

- A. Contractor's vehicles and employee parking shall be confined to an area identified within the site limits and as directed by the Owner.

2.03 STAGING

- A. Contractor shall confine materials, products, equipment and temporary facilities within site limits and as directed by the Owner.

PART 3 – EXECUTION

3.01 REMOVAL

- A. Temporary construction access roads, drives, walks, and parking areas shall be removed at completion of Work or as required by execution of Work at the Contractor's sole cost and expense.
- B. Areas shall be returned to original condition unless otherwise required by the Owner.

END OF SECTION 01550

[REMAINDER OF PAGE INTENTIONALLY LEFT BLANK]

SECTION 01563

HANDLING OF INCIDENTAL FUEL SPILLAGE

PART 1 – GENERAL

1.01 RELATED REQUIREMENTS

- A. Division 0, Bidding and Contract Documents in the Project Manual.
- B. Division 1, General Requirements in the Project Manual.
- C. South Carolina Dept. of Health and Environmental Controls (SCDHEC)

1.02 SCOPE

- A. This section consists of procedures to be followed in handling material contaminated with petroleum fuel products (hydrocarbons including petroleum, petroleum derivatives, hydraulics and like products) caused by incidental spillage (including leaks) from the Contractor's or his/her prime and sub-contractor's equipment.

Incidental spillage shall mean spillage of a quantity not greater than 25 gallons per incident, of vehicular or mechanical equipment fuel products, onto open ground and absorbed or not absorbed by the soils.

Spillage or leakage of petroleum fuel products in quantities in excess of 25 gallons shall be immediately remediated by the Contractor using applicable and appropriate procedure(s). Whenever such spillage or leakage occurs, the Contractor shall immediately implement the appropriate corrective actions as required.

- B. The provisions of this Section are limited to incidental petroleum fuel spillage on ground surfaces and it excludes fuel spillage onto surface waters.

1.03 APPLICABLE CODES

- A. The Contractor shall comply with all prevailing federal, state, and local environmental protection ordinances and codes governing and having application to and any discharges, intentional or accidental, which may cause water pollution and constitute a nuisance, and sanitary nuisance.
- B. Leaks and spillage may occur when using mechanical equipment. Equipment generated or lubricated with petroleum products, is prone to leaks or spillages, therefore proper management of "spillage incidents" is essential.

PART 2 – PRODUCTS

2.01 ABSORBENT MATERIALS

Contractor shall equip crews and/or provide machinery with the most efficient type of petroleum absorbent materials. These materials are available at petroleum equipment suppliers and must be readily accessible so that spillages can be quickly contained and prevented from becoming greater incidents. Fiber material, sand or cat litter may be used as an absorbent material. Sufficient quantity of absorbent material capable of absorbing up to 25 gallons of petroleum fuel products shall be stocked at the job site at all times.

PART 3 - EXECUTION

3.01 PROCEDURES

- A. Personnel handling waste materials must have a minimum of 40 hours training as defined in 29 CFR 1910.120 and in accordance with the certified OSHA course.
- B. Perform work as specified herein and in accordance with the applicable provisions of South Carolina Dept. of Transportation (SCDOT) and South Carolina Dept. of Health and Environmental Controls (SCDHEC). No payment will be made to the Contractor for the cost of handling and disposing of leaks, spillages and materials, soils and environment contaminated by such leaks or spillages.

The procedure for the proper handling and disposal of contaminated soils and absorbent materials is readily available through the aforementioned agencies:

- C. The steps outlined below are minimum requirements and are merely presented as guidelines. They do not constitute a complete compliance procedure.

STEP 1:

If a fuel contamination to open ground has been discovered, check for the origin of that leak or spillage. Then stop the spillage or leak and positively contain it, and then use absorbents to collect the discharged liquid. Immediately notify the Owner.

STEP 2:

Sand may be used to absorb ground surface spills while absorbent materials may be used to absorb ground spills as well as surface water spills.

Once absorption of spilled fuels is complete the impacted (contaminated) absorbent materials shall be stored in 55-gallon steel drums (100-150 lbs.). If leaked or spilled fuel has been absorbed into the soils, excavate and containerize the impact (contaminated) soils. Soils may be stored in 55- gallon steel drums.

STEP 3:

The contaminated materials must be collected, containerized and otherwise properly stored and labeled prior to transport to a pre-approved storage, disposal or treatment facility. All drums used to store impacted (contaminated) absorbent material and/or contaminated soils shall be properly sealed and labeled with the following information.

Name of Company (Contractor)

RFP / Bid No.:

Location of origin:

Type of contents:

Type of containment:

Quantity: (e.g. 1 of 1)

Date:

Containerized by:

Labeled by:

END OF SECTION 01563

[REMAINDER OF PAGE INTENTIONALLY LEFT BLANK]

SECTION 01570

TRAFFIC REGULATION

PART 1 – GENERAL

1.01 REQUIREMENTS INCLUDED

- A. The Contractor shall comply with and be responsible for all of the requirements of the Project Manual, without exception.
- B. Construction parking control, flagmen, flares and lights, haul routes, traffic signs and signals, and removal.
- C. The Contractor shall comply with and be responsible for traffic control planning and implementation as may be directed and approved by SCDOT and the Owner.
- D. Maintenance of safety and convenience of public.

1.02 RELATED WORK

- A. Division 1, General Requirements of the Project Manual.

1.03 PUBLIC SAFETY AND CONVENIENCE

- A. Materials and equipment shall be stored and Work conducted to minimize obstruction to pedestrian movement and vehicular traffic. Materials and equipment stored in or near path of traffic shall be protected with appropriate warning signs and barricades. At night, or as otherwise required, equipment not in use shall be stored in such manner and location to not interfere with safe passage of pedestrians and vehicles. Contractor shall provide and maintain flagmen at points and for periods of time required to provide safety and convenience of traffic, and as may be required by the SCDOT and as directed by the Owner
- B. Contractor shall not close traffic to any bridge, culvert, or any other portion of public road except as designated in the Construction Contract Documents. Prior to closing any access way and/or structure coordinate Work schedule with the Owner and the SCDOT if applicable.
- C. Contractor shall provide the Owner with notice at no less than 48 hours prior to movement of heavy equipment and/or wide or slow moving vehicles to or from Project Site. Contractor shall strictly adhere to vehicular routes established or as may be directed by the Owner and / or the SCDOT if applicable.

1.04 HAUL ROUTES

- A. Based on regulations prescribed by the South Carolina Dept. Transportation (SCDOT), Georgetown County or any other agency having jurisdiction, use only established roadways or use temporary roadways constructed by Contractor when and as authorized by the Owner. When materials are transported in executing the Work vehicles shall not be loaded beyond loading capacity recommended by manufacturer of vehicle or prescribed by federal, state, or local law or regulation. When it is necessary to cross curbs or sidewalks, Contractor shall protect them from damage, and shall repair or pay for repair of all damaged curbs, sidewalks, roads and/or paving.

1.05 TRAFFIC SIGNS AND SIGNALS

- A. At approaches to site and on-site, install signs or signals at crossroads, detours, parking areas, and elsewhere as needed to direct construction and affected public vehicular and pedestrian traffic. This should be included in the Contractor's approved Traffic Control Plan.
- B. Install and operate traffic control signals to direct and maintain orderly flow of traffic in areas under Contractor's control, and areas affected by Contractor's operations.
- C. Relocate traffic control signs and signals as Work progresses, to maintain safe and effective traffic control.
- D. Coordinate with construction signs described in Section 01580, Project Identification and Signs.

1.06 FLAGMEN

- A. Provide trained and equipped flagmen to regulate traffic when construction operations and/or traffic encroach on public vehicular or pedestrian traffic lanes.

1.07 FLARES AND LIGHTS

- A. Use flares and lights during hours of low visibility to delineate traffic lanes and to guide traffic in landside areas only.

PART 2 – PRODUCTS

2.01 SIGNS, SIGNALS AND DEVICES

- A. Post-mounted and wall-mounted at parking areas to indicate spaces designated for use by construction personnel.
- B. Traffic control signals, as required, and as approved by SCDOT and the Owner.
- C. Traffic cones and drums and lights, as approved by SCDOT and the Owner.
- D. Flagmen equipment as required by SCDOT and the Owner.

PART 3 – EXECUTION

3.01 REMOVAL

- A. Contractor shall remove equipment and devices, at his/her sole cost, when no longer required. Repair damage caused by installation. Remove post settings to depth of three (3) feet.

END OF SECTION 01570

[REMAINDER OF PAGE INTENTIONALLY LEFT BLANK]

SECTION 01580

PROJECT IDENTIFICATION AND PERMIT BOX

PART 1 – GENERAL

1.01 REQUIREMENTS INCLUDED

- A. The Contractor shall comply with and be responsible for all requirements of the Project Manual, without exception.
- B. The Contractor shall comply with applicable requirements in this Section and more specific requirements of Section 00800, Special Project Conditions and Section 01100, Summary of Work.
- C. Furnish, install and maintain typical Permit Box as approved by the Owner.
- D. Provide temporary, on site informational signs to identify key elements of the construction facilities.
- E. Remove the Permit Box upon completion of the construction Work of this contract.
- F. Permit Box to be mounted on a utility pole near the project entrance within fifteen (15) calendar days of the Notice to Proceed (NTP).

1.02 RELATED REQUIREMENTS

- A. Division 1, General Requirements of the Project Manual.

PART 2 – PRODUCTS

2.01 SIGN MATERIALS

To Be Determined By the Owner

2.02 TEMPORARY SIGNAGE

To Be Determined By the Owner

PART 3 – EXECUTION

3.01 PREPARATION

The Contractor shall be responsible for the cost of preparing and installing the Permit Box

3.02 MAINTAINANCE

The Contractor shall be responsible for the cost of maintaining the Permit Box.

3.03 REMOVAL

The Contractor shall be responsible for the cost of removing the Permit Box.

END OF SECTION 01580
[REMAINDER OF PAGE INTENTIONALLY LEFT BLANK]

SECTION 01600

PRODUCT REQUIREMENTS

PART 1 - GENERAL

1.1 RELATED REQUIREMENTS

- A. Division 0, Bidding and Contract Documents of the Project Manual without exception.
- B. Division 1, General Requirements of the Project Manual without exception.

1.2 SUMMARY

- A. This Section specifies administrative and procedural requirements for handling requests for substitutions made after award of the Construction Contract.
- B. Procedural requirements governing the Contractor's selection of products and product options are included under Section 01610, Materials and Equipment.

1.3 DEFINITIONS

- A. Definitions used in this Section are not intended to change or modify the meaning of other terms used in the Contract Documents.
- B. Substitutions: Requests for changes in products, materials, equipment, and methods of construction required by Contract Documents proposed by the Contractor after award of the Contract are considered requests for "Substitutions." The following are not considered substitutions:
 - 1. Substitutions requested by Bidders during the bidding period, and accepted prior to award of Contract, are considered as included in the Construction Contract Documents and are not subject to requirements specified in this Section for substitutions.
 - 2. Revisions to Construction Contract Documents requested by Georgetown County
 - 3. Specified options of products and construction methods included in Contract Documents.
 - 4. The Contractor's determination of and compliance with governing regulations and orders issued by governing authorities.

1.4 SUBMITTALS

- A. Substitution Request Submittal: Requests for substitution will be considered if received within thirty (30) calendar days after commencement of the Work. Requests received more than thirty (30) calendar days after commencement of the Work may be considered or rejected at the discretion of the Owner.
 - 1. Submit three (3) copies of each request for substitution for consideration. Submit requests in the form to be provided by the Owner and in accordance with procedures required for Change Order proposals to be established by the Owner
 - 2. Identify the product, or the fabrication or installation method to be replaced in each request. Include related Technical Specification Section and Drawing numbers. Provide complete documentation showing compliance with the requirements for substitutions, and the following information, as appropriate:

- a. Product Data, including Drawings and descriptions of products, fabrication and installation procedures.
 - b. Samples, where applicable or requested.
 - c. A detailed comparison of significant qualities of the proposed substitution with those of the Work specified. Significant qualities may include elements such as size, weight, durability, performance and visual effect.
 - d. A statement indicating the substitution's effect on the Contractor's Construction Progress Schedule compared to the schedule without approval of the substitution. Indicate the effect of the proposed substitution on overall Contract Time.
 - e. Cost information, including a proposal of the net change, if any in the Contract Sum.
 - f. Certification by the Contractor that the substitution proposed is equal-to or better in every significant respect to that required by the Construction Contract Documents. Include the Contractor 's waiver of rights to additional payment or time that may subsequently become necessary because of the failure of the substitution to perform adequately.
3. Owner's Action: Within one (1) week of receipt of the request for substitution, the Owner may request additional information or documentation necessary for evaluation of the request. Within two (2) weeks of receipt of the request, or one (1) week of receipt of the additional information or documentation, whichever is later, the Owner will notify the Contractor of acceptance or rejection of the proposed substitution. If a decision on use of a proposed substitute cannot be made or obtained within the time allocated, use the product specified by name. Acceptance will be in the form of a Change Order.

PART 2 - PRODUCTS

2.1 SUBSTITUTIONS

- A. Conditions: The Contractor's substitution request will be received and considered by the Owner when one or more of the following conditions are satisfied, as determined by the Owner, otherwise requests will be returned without action except to record noncompliance with these requirements.
1. Extensive revisions to Construction Contract Documents are not required.
 2. Proposed changes are in keeping with the general intent of the Construction Contract Documents.
 3. The request is timely, fully documented and properly submitted.
 4. The request is directly related to an "or equal" clause or similar language in the Construction Contract Documents.
 5. The specified product or method of construction cannot be provided within the Contract time. The request will not be considered if the product or method cannot be provided as a result of failure to pursue the Work promptly or coordinate activities properly.
 6. The specified product or method of construction cannot receive necessary approval by a governing authority, and the requested substitution can be approved.
 7. A substantial advantage is offered the Owner in terms of cost, time, energy conservation or other considerations of merit after deducting offsetting responsibilities the Owner may be required to bear. Additional responsibilities for the Owner may include additional compensation to the Architect / Engineer of record for redesign, increased cost of other construction elements by the Owner or other separate Contractors, and similar considerations.

8. The specified product or method of construction cannot be provided in a manner that is compatible with other materials, and where the Contractor certifies that the substitution will overcome the incompatibility.
 9. The specified product or method of construction cannot be coordinated with other materials, and where the Contractor certifies that the proposed substitution can be coordinated.
 10. The specified product or method of construction cannot provide a warranty required by the Construction Contract Documents and where the Contractor certifies that the proposed substitution will provide the required warranty.
- B. The Contractor's submittal and the Owner's acceptance of Shop Drawings, Product Data or Samples that relate to construction activities not complying with the Contract Documents does not constitute an acceptable or valid request for substitution, nor does it constitute approval.
- C. Substitution request constitutes a representation that the Contractor:
1. Has investigated the proposed product and determined that it meets or exceeds, in all respects, the product specified.
 2. Will provide the same warranty for substitution as for the product specified.
 3. Will coordinate installation and make other changes, which may be required for work to be complete in all respects.
 4. Waives claims for additional costs, which may subsequently become apparent. All costs associated with the substitution will be paid for by the Contractor regardless of approvals given, and regardless of subsequent difficulties experienced as a result of substitutions.

PART 3 - EXECUTION

Not Used

END OF SECTION 01600

[REMAINDER OF PAGE INTENTIONALLY LEFT BLANK]

SECTION 01610

MATERIALS AND EQUIPMENT

PART 1 - GENERAL

1.01 REQUIREMENTS INCLUDED

- A. The Contractor shall comply with and be responsible for all requirements of the Project Manual, without exception.
- B. The Contractor shall comply with the applicable requirement in this Section, and the requirements of Division 1, Section 01100 Summary of Work.
- C. Division 1, Section 01600, Product Requirements.
- D. Division 1, Section 01770, Closeout Procedures

1.02 RELATED WORK

- A. Division 1, General Requirements of the Project Manual.

1.03 SCOPE

- A. General storage and protection of project materials and equipment.
- B. Furnish, install and maintain storage sheds as required for protection of materials and equipment. Remove at completion of Work.
- C. Exterior storage requirements for all specified materials and equipment requiring protection.

1.04 MATERIAL AND EQUIPMENT INCORPORATED INTO WORK

- A. Comply with applicable specifications, manufacturer's recommendations and standards.
- B. Comply with size, make, type and quality specified or as specifically accepted in writing by the Owner.
- C. Design, fabricate, assemble deliver and install products in accordance with engineering and shop practices normal to trade.
- D. Manufacture like parts of duplicate units to standard interchangeable sizes and gauges. Two or more items of same kind shall be identical by same manufacturer.
- E. Products shall be suitable for intended purpose.
- F. Equipment capacities, sizes and dimensions shown or specified shall be adhered to unless variations are specifically accepted in writing.

- G. Do not use material or equipment for any purpose other than for which it is designed or is specified.

1.05 IDENTIFICATIONS AND NAMEPLATES

- A. Nameplates, trademarks, and other identifying marks on manufactured and fabricated items are not permitted on surfaces exposed to view in public spaces, including elevators and escalators except as noted otherwise in the Construction Contract Documents. This does not apply to UL labels.

1.06 QUALITY ASSURANCE

- A. Materials specified are to define standard of quality or performance and to establish basis for evaluation of proposals.
- B. Comply with individual Technical Specification Sections and referenced standards as minimum requirements.
- C. Components required to be supplied in quantity within a Technical Specification Section shall be of same manufacturer and shall be interchangeable, unless otherwise required.

1.07 PRODUCT OPTIONS

- A. For Products specified only by reference standard, select Product meeting that standard by any manufacturer.
- B. For Products specified by naming only one Product and manufacturer, select any one of the products and manufacturers named which complied with the Technical Specifications.
- C. For products specified by naming only one Product and manufacturer, there is no option and no substitution will be allowed.

1.08 PRODUCTS LIST

- A. Within twenty (20) calendar days after award of Contract, submit to the Owner three (3) copies of complete list of major Products, which are proposed for installation.
- B. Tabulate Products by Technical Specification Section number and title.
- C. For products specified only by reference standards list for each such Product:
 - 1. Name and address of manufacturer.
 - 2. Trade name.
 - 3. Model or catalogue designation.
 - 4. Manufacturer's data:
 - a. Reference standards.
 - b. Performance test data.
- D. The Owner will coordinate with the Architect / Engineer of record and reply in writing stating whether there is reasonable objection to listed items. Failure to object to a listed item shall not constitute a waiver of the requirements of the Construction Contract Documents.

1.09 MANUFACTURER'S INSTRUCTIONS

- A. When Construction Contract Documents require installation of work to comply with manufacturers printed instructions, obtain and distribute copies of instructions to parties involved in installation, including two (2) copies to the Owner, prior to commencing work.
- B. Maintain one (1) set of complete instructions at job site during installation and until work is complete.
- C. Maintain copies for Project Record Documents.
- D. Handle, install, connect, clean, condition and adjust products in strict accord with manufacturer's instructions and in conformity with specified requirements.
- E. Should job conditions or specified requirements conflict with manufacturer's instructions, notify the Owner in writing for further instructions. Do not proceed with Work without clear instructions.
- F. Perform Work in accordance with manufacturer's instructions. Do not omit preparatory steps on installation procedures unless specifically modified or exempted by the Contract Documents.

1.10 TRANSPORTATION AND HANDLING

- A. Arrange deliveries of materials and equipment in accordance with construction schedules. Coordinate to avoid conflict with Work and conditions at Site. Avoid congesting traffic.
- B. Deliver materials and equipment in undamaged condition, in manufacturer's original containers or packaging, with identifying labels intact and legible.
- C. Immediately upon delivery, inspect shipments to assure compliance with requirements of the Construction Contract Documents and accepted submittals, and that products are properly protected and undamaged.
- D. Promptly remove unsatisfactory materials from Site.
- E. Furnish equipment and personnel to handle products by methods necessary to prevent soiling or damage to products or packaging.

1.11 STORAGE

- A. Store materials subject to damage from exposure to weather in weather tight storage facilities of suitable size with floors raised above ground. Materials not subject to weather damage may be stored on blocks off ground.
- B. Store fabricated products in accordance with manufacturer's instructions, seals and labels intact and legible. Store product subject to damage by elements in weather tight enclosures. Maintain temperature and humidity within ranges required by manufacturer's instructions.
- C. Cover materials, which are subject to deterioration with breathable, impervious sheet covering to provide adequate ventilation to avoid condensation.
- D. Store loosed granular materials in well-drained area on solid surfaces to prevent mixing with foreign matter and cover during inclement weather. Store cementitious and clay products clear of earth or concrete floors, away from walls.

- E. Arrange storage in manner to permit easy access for inspections.
- F. Protect metal from damage, dirt or dampness. Furnish flat, solid support for sheet products during storage.
- G. Make periodic inspections of stored materials to verify that products are maintained under specified conditions and are free from damage or deterioration.
- H. Do not use materials in work that have deteriorated, become damaged or are otherwise unfit for use.
- I. Store paints in assigned room or area kept under lock and key. Prevent mixing of refuse or chemically injurious materials or liquids with stored materials.
- J. Remove oil, rags and other combustible materials daily and take precautions to prevent fire hazard.
- K. Do not load structure during construction by storing materials with load greater than structure is calculated to support safely. Such storage is subject to approval by the Owner.
- L. Provide substantial platforms, blocking, or skids to support fabricated products above ground; slope to provide drainage. Provide surface drainage to prevent erosions and pounding of water.
- M. Pipe and conduit stored outdoors shall have open ends sealed to prevent entrance of dirt, moisture, etc.

1.12 PROTECTION AND MAINTENANCE

- A. Furnish protection against weather. Cover building openings and penetrations to protect interior of building from weather.
- B. Maintain work, materials, apparatus and fixtures free from damage, accumulation of debris, and protected from dust and dirt.
- C. Protect items having factory finish to prevent damage to finish and equipment.
- D. At end of day's work, cover new work likely to be damaged or otherwise protect and necessary.
- E. After installation, secure substantial coverings as necessary to protect installed products from damage from traffic and subsequent construction operations.
- F. Remove protection where no longer needed. Upon completion of Work, remove storage facilities from site.
- G. Contractor shall replace, at no additional cost to the Owner, stored items damaged by inadequate protection and environmental control.
- H. For mechanical and electrical equipment in long-term storage, provide manufacturer's service instructions shown on exterior of package.

- I. Service equipment on a regular basis as recommended by manufacturer. Maintain log of maintenance services; submit log as Project Record Document in accordance with requirements of Section 01781, Project Record Documents.
- J. After cabinets and boxes are installed, cover openings to prevent entrance of water and foreign materials. Close conduit openings with temporary metal or plastic cap, including those terminated in cabinets.
- K. Provide temporary enclosures for equipment such as substations and motor control centers. Provide and maintain heat in closures until equipment is energized, to avoid condensation damage.

1.13 MANUFACTURER CERTIFICATION

- A. Prior to Final Acceptance of Work, for items designated in Technical Specifications Sections, an authorized representative of each manufacturer of materials and/or equipment installed under the work of that Section, shall personally inspect installation and operation of his/her materials, system and equipment to determine they are correctly installed and operating properly as follows:
 - 1. Inspection and testing shall be accomplished:
 - a. For Work which will be concealed during execution of Work, after completion of installation and prior to concealment.
 - b. For Work which will not be concealed, at completion of Work.
 - 2. Each representative shall submit a signed statement to the Owner through the Contractor certifying to his personal inspection and to the correct installation and proper operation of materials, systems and/or equipment. Their certification shall list all items included.
 - 3. Contractor shall transmit all such certifications to the Owner at or prior to Final Acceptance Inspection. Transmittal shall include a list of all certifications included.

PART 2 - PRODUCTS

2.01 MATERIALS, EQUIPMENT & FURNISHINGS

- A. Materials and equipment intended for use in Project must be new. Equipment and furnishings utilized for installation of material and equipment in the Project may be new or used, but must be serviceable, must be adequate for intended purpose, and must not violate applicable codes and/or regulations.

PART 3 - EXECUTION

3.01 GENERAL

- A. Store products immediately upon delivery at location acceptable to the Owner, in accordance with manufacturer's storage instructions, with seals and labels intact. Protect until uninstalled.
- B. Arrange storage in manner to provide access for maintenance of stored items and for inspection.

3.02 MAINTENANCE OF STORAGE

- A. Verify that storage facilities comply with manufacturer's product storage requirements.
- B. Verify that manufacturer required environmental conditions are maintained continually.
- C. Verify that surfaces of products to elements are not adversely affected and that any weathering of finishes is within acceptable tolerances under requirements of Construction Contract Documents.

END OF SECTION 01610

SECTION 01620

STORAGE AND PROTECTION

PART 1 – GENERAL

1.01 REQUIREMENTS INCLUDED

- A. General storage and protection of project materials and equipment.
- B. Furnish, install and maintain storage sheds as required for protection of materials and equipment. Remove at completion of Work.
- C. Exterior storage requirements for all specified materials and equipment requiring protection.

1.02 RELATED REQUIREMENTS

- A. Division 1, General Requirements in the Project Manual without exception..

PART 2 – PRODUCTS

2.01 MATERIALS, EQUIPMENT & FURNISHINGS

- A. Materials and equipment intended for use in Project must be new. Equipment and furnishings utilized for installation of material and equipment in the Project may be new or used, but must be serviceable, must be adequate for intended purpose, and must not violate codes or regulations.

PART 3 – EXECUTION

3.01 GENERAL

- A. Store products immediately upon delivery at location acceptable to the Owner, in accordance with manufacturer's storage instructions, with seals and labels intact. Protect until installed.
- B. Arrange storage in manner to provide access for maintenance of stored items and for inspection.

3.02 ENCLOSED STORAGE

- A. Store products subject to damage by elements in substantial weather tight enclosures or storage sheds of adequate dimensions.
- B. Maintain temperature and humidity within ranges stated in manufacturer's instruction.
- C. Provide humidity control and ventilation for sensitive products as required by manufacturer's instruction.
- D. Store unpacked and loose products on shelves, in bins, or in neat groups of like items.
- E. Contractor shall replace, at no additional cost to the Owner, store items damaged by inadequate protection or environmental control.

- F. Provide substantial platforms, blocking, or skids to support fabricated products above ground; slope to provide drainage.
- G. For products subject to dislocation or deterioration from exposure to elements, cover with impervious sheet materials. Provide ventilation to prevent condensation below covering.
- H. Store loose, granular materials on clean, solid surfaces, or on rigid sheet materials, to prevent mixing with foreign matter.
- I. Provide surface drainage to prevent erosion and pounding of water.
- J. Prevent mixing of refuse or chemically injurious materials or liquids with stored material.
- K. Pipe and conduit stored outdoors shall have open ends sealed to prevent entrance of dirt, moisture, etc.

3.03 MAINTENACE OF STORAGE

- A. Periodically inspect stored products on a scheduled basis.
- B. Verify that storage facilities comply with manufacturer's product storage requirements.
- C. Verify that manufacturer required environmental conditions are maintained continually.
- D. Verify that surfaces of products exposed to elements are not adversely affected and that any weathering of finishes is within acceptable tolerances established by the applicable manufacturer.

3.04 MAINTENACE OF EQUIPMENT STORAGE

- A. For mechanical and electrical equipment in long-term storage, provide manufacturer's service instructions shown on exterior of package.
- B. Service equipment on a regular basis as recommended by manufacturer. Maintain log of maintenance services; submit log in accordance with requirements of Section 01781, Project Record Documents

3.05 PROTECTION OF INSTALLED EQUIPMENT

- A. After cabinets and boxes are installed, cover openings to prevent entrance of water and foreign materials. Close conduit openings with temporary metal or plastic cap, including those terminated in cabinets.
- B. Provide temporary enclosures for equipment such as substations and motor control centers. Provide and maintain heat in closures until equipment is energized, to avoid condensation damage.

END OF SECTION 01620

SECTION 01700

EXECUTION REQUIREMENTS

PART 1- GENERAL

1.01 REQUIREMENTS INCLUDED

- A. Contractor shall comply with and be responsible for all of the requirements of the Project Manual without exception.
- B. Contractor shall provide field engineering and general layout services required on the project as follows:
 - 1. Civil, structural or other professional engineering services specified, or required to execute construction methods consistent with the requirements of the Construction Contract Documents.
 - 2. Survey work required for execution of the total Work.
 - 3. Continuous horizontal and vertical control regarding layout and execution of Work.
 - 4. Coordinate field engineering services with the Owner.

1.02 RELATED REQUIREMENTS

- A. Division 1, General Requirements of the Project Manual without exception.
- B. The Technical Specifications, Sections 0200 through 1900, as may be applicable.

1.03 CONTROLS

- A. Contractor will establish primary controls, horizontal and vertical control points at various locations at the Site. These will be described and indicated on the Contractor's approved Drawings and will be coordinated in the field by the Contractor.
- B. Existing control points and property line markers will be shown on the Owner's survey drawings.

1.04 QUALIFICATIONS OF SURVEYOR OR ENGINEER

- A. For Surveying, a qualified engineer or registered land surveyor, registered in the State of South Carolina and acceptable to the Owner.
- B. For engineering, a registered professional engineer of a discipline required for this Project licensed in the State of South Carolina and acceptable to the Owner.

1.05 SURVEY REFERENCE POINTS

- A. Existing horizontal and vertical control points for the Project are those designated on Owner's survey drawings or as determined from investigation of the existing conditions.
- B. Verify property, grades, lines, levels and dimensions indicated.

- C. Locate and protect control points prior to starting Site Work and preserve permanent reference points during construction.
 - 1. Make no changes or relocations without prior approval of the Owner
 - 2. Report to the Owner when a reference point is lost, destroyed or requires relocation because of necessary changes in grades or locations.
 - 3. Require surveyor to replace Project control points, which may be lost or destroyed.

1.06 PROJECT LAYOUT REQUIREMENTS

- A. Establish a sufficient number of permanent bench marks on Site, as may be required, referenced to data established by survey control points. Record locations of benchmarks with horizontal and vertical data on Project Record Documents, Section 01781.
- B. From established control points, Contractor shall layout all Work by establishing all lines and grades at Site necessary to control Work, and shall be responsible for all measurements that may be required for execution of Work.
- C. Furnish, at own expense, all such stakes, steel pins, equipment, tools and material and labor that may be required in laying out Work control points.
- D. Establish lines and levels, locate and layout by instrumentation and similar appropriate means:
 - 1. Site Improvements
 - a. Stakes for grading, fill, and topsoil placement.
 - b. Utility slopes and invert elevations.
 - c. Limits of pavement (concrete and asphalt).
 - 2. Batter boards for structures.
 - 3. Building foundation column locations, piling and floor levels.
 - 4. Controlling lines and levels required for mechanical and electrical trades.
- E. Verify and coordinate in field all existing and proposed underground components including civil, structural, utilities and other components prior to initiation of the Work. Advise the Owner of any conflicts or discrepancies.

1.07 SUBMITTALS AND DOCUMENTS

- A. Submit name and address of Surveyor and Professional Engineer assigned to the Project to the Owner.
- B. On request of the Owner, submit documentation to certify accuracy of field engineering work and compliance with Construction Contract Documents.
- C. Submit certificate signed by registered engineer or surveyor certifying that elevations and locations of improvements are in conformance, or non-conformance, with Construction Contract Documents.
- D. Standards and Availability: Data and other measurements shall be recorded in accordance with standard and approved methods. All field notes, sketches, recordings, and computation in establishing above horizontal and vertical control points shall be available at all times during progress of Work for ready examination by the Owner

- E. Maintain complete and accurate record data on underground utilities and obstructions, new and existing, encountered in execution of Work. Record data on Project Record Documents in accordance with requirements of Section 01781, Project Record Documents.
- F. On completion of all foundation walls, pavement and other major site improvements, prepare certified survey showing dimensions, locations, angles, and elevations of construction.

PART 2 – PRODUCTS

Not Used

PART 3 – EXECUTION

Not Used

END OF SECTION 01700

[REMAINDER OF PAGE INTENTIONALLY LEFT BLANK]

SECTION 01710

FINAL CLEANING

PART 1 – GENERAL

1.01 REQUIREMENTS INCLUDED

- A. Contractor shall comply with and be responsible for all requirements of the Project Manual, without exception.
- B. Contractor shall comply with applicable requirements in this Section and more specific requirements in Section 00800, Special Project Conditions, and Section 01100, Summary of Work.
- C. Execute final cleaning at completion of the Work as required by the Construction Contract Documents.

1.02 RELATED REQUIREMENTS

- A. Divisions 1, General Requirements in the Project Manual without exception.

1.03 DISPOSAL REQUIREMENTS

- A. Conduct cleaning and disposal operations to comply with all applicable codes, ordinances, regulations, and anti-pollution laws.

PART 2 – PRODUCTS

2.01 MATERIALS

- A. Use only those cleaning materials which will not create hazards to health or property and which will not damage surfaces.
- B. Use only those cleaning materials and methods recommended by manufacturer of the surface material to be cleaned.
- C. Using cleaning materials only on surfaces recommended by cleaning material manufacturer.
- D. Refer to applicable manufacturer's recommendations for specific products and materials.

PART 3 – EXECUTION

3.01 FINAL CLEANING

- A. Execute prior to inspection at Substantial Completion.
- B. Employ skilled workmen or professional cleaners for the final cleaning.
- C. In preparation for substantial completion or occupancy, conduct final inspection of sight-exposed interior and exterior surfaces, and of concealed spaces, and clean as follows:
 - 1. Remove grease, dust, dirt stain, labels, fingerprints, and other foreign materials from site-exposed interior and exterior surfaces; wash and polish surfaces so designated to shine finish.

- 2. Repair, patch and touch-up marred surfaces to specified finish, to match adjacent surfaces.
- D. Broom clean exterior paved surfaces; rake clean other surfaces of the grounds.
- E. Clean roof areas of debris; flush roof drainage system(s) with water until clear.
- F. Prior to final completion, or Owner occupancy, Contractor and Owner shall conduct an inspection of sight-exposed interior and exterior surfaces, and all work areas, to verify that the entire Project Work area is clean.
- G. Leave Project Work area clean and ready for use and occupancy.

END OF SECTION 01710

[REMAINDER OF PAGE INTENTIONALLY LEFT BLANK]

SECTION 01770

CLOSEOUT PROCEDURES

PART 1 – GENERAL

1.01 REQUIREMENTS INCLUDED

- A. The Contractor shall comply with and be responsible for all of the requirements of the Project Manual, without exception.
- B. The Contractor shall comply with applicable requirements in this Section and more specific requirements in Division 1, Section 01100, Summary of Work.
- C. The Contractor shall comply with the requirements stated in the Construction Contract and in approved and permitted Drawings and Technical Specifications for the Work.

1.02 RELATED REQUIREMENTS

- A. Conditions of the Construction Contract: fiscal provisions, legal submittals and additional administrative requirements.
- B. Division 1, General Requirements in the Project Manual without exception.
- C. Closeout submittals required of trades as may be indicated in various sections of the approved Technical Specifications.

1.03 DAMAGES

- A. If the Contractor neglects, fails, or refuses to complete the work by the Substantial Completion Date, Final Completion Date, or any portion of the Work by an Interim Completion Date, subject to any proper extension granted by the Owner, then the Contractor will pay, or cause the Contractor's Surety to pay damages to the Owner as defined in Summary of the Work, Section 01100.

1.04 PHASED COMPLETION

- A. In addition to Substantial Completion (Beneficial Occupancy) and Final Completion as defined below, the Contractor shall complete and make available to the Owner certain portions of the Work set forth on the Summary Schedule and Key Milestones in Section 00750 no later than the dates indicated on said Schedule ("Interim Completion Date")
- B. The Contractor acknowledges that such Interim Completion Dates are essential to the Owner's plans and use and, therefore, time is of the essence in meeting said Interim Completion Dates.

1.05 SUBSTANTIAL COMPLETION

- A. When Contractor considers the Work is substantially complete, he shall submit to the Owner the following:
 - 1. The Owner shall be notified by the Contractor once the Work is substantially complete (when all the punch list items have been addressed).

2. The Owner will schedule an inspection within ten (10) calendar days of the notification.
- B. After Work is substantially complete, Contractor shall:
1. Complete Work listed for completion or correction within designated form.
 2. Perform all cleaning in accordance with Section 01710, Final Cleaning.

1.06 FINAL COMPLETION

- A. Within ten (10) calendar days after substantial completion, the Contractor shall submit to the Owner written certification that:
1. Construction Contract Documents have been reviewed.
 2. Work has been examined for compliance with Construction Contract Documents.
 3. Work has been completed in accordance with Construction Contract Documents.
 4. Equipment and systems have been tested in the presence of the Owner and the appropriate County personnel, and are operational.
 5. Work is completed and ready for final examination.
 6. Submittal of Closeout Documents as stipulated in paragraph 1.07 below.
- B. The Owner will make an examination to verify the status of completion within ten (10) calendar days after receipt of such certification.
- C. Should the Owner consider the Work incomplete or defective, or the Contractor has not demonstrated to the Owner that a “good faith” effort has been made within the time (72 hours) allotted in paragraph 1.05 A above, any Damages and/or Liquidated Damages, will be charged against the Contractor as defined and explained in Section 01100, Summary of Work
1. The Owner will promptly notify the Contractor in writing of all deficiencies listing the incomplete or defective work.
 2. Contractor shall take immediate steps to remedy the stated deficiencies, and send a second written Certification to the Owner that the Work is complete.
 3. The Owner will re-examine the Work.
- D. When the Owner concludes that the Work is complete, the Owner shall determine the number of days for which Liquidated Damages will be assessed and request the Contractor to prepare closeout submittals.
- E. Acceptance of the entire project shall commence after all contract work is complete, final inspections are made, corrective actions completed, the Work re-examined, and after final acceptance by the Owner
- F. The date established by the Owner as the Final Completion Date shall initiate the guarantee and the warranty periods for all system components and the construction of the Project. The Project shall

not be considered Final Complete until all Close Out Documents are properly completed and transmitted to the Owner.

- G. G. The Owner shall review the status of the Work and compare it to the request for final payment and compare it with the Project records for conformance to the final settlement requirements.
- H. The Owner shall receive from the Contractor, and maintain, the permit drawings and specification package, copy of all shop drawings and submittals, the “as-built” set of drawings (unless waived by the Owner) and specifications, maintenance manuals as required by the contract and submitted by the Contractor. In addition, the Contractor shall provide spare parts and supplies, stored materials, special tools, filters, and other pertinent items as required under the Construction Contract Documents to the Owner for transmittal to the appropriate County department(s)

1.07 CLOSEOUT SUBMITTALS

- A. Evidence of compliance with requirements of governing authorities:
 - 1. Certificates of Inspection:
- B. Project Record (Permit) Documents, in accordance with Section 01781
- C. Operating and Maintenance Data, in accordance with Section 01782
- D. Warranties and Bonds, in accordance with Section 01790.
- E. Spare Parts and Maintenance Materials, in accordance with Section 01785.
 - 1. Provide products, spare parts, and maintenance materials in quantities specified in each approved Specification Section in addition to that required for completion of Work.
- F. Certificate of Insurance for Products and Completed Operations.

1.08 EVIDENCE OF PAYMENTS AND RELEASE OF LIENS

- A. Contractor s Affidavit of Release of Liens.
 - 1. Consent of Surety to Final Payment. Use form acceptable to the Owner
 - 2. Contractor’s Release or Waiver of Liens. Standard Form “Affidavit and Partial Lien Waiver”. Use form acceptable to Owner.
 - 3. Separate releases of waivers of liens from prime and subcontractors, suppliers and others with lien rights against property of the Owner together with a list of those parties, in accordance with Standard Form “Affidavit and Final Lien Waiver”. Use form acceptable to Owner.
- B. All submittals shall be duly executed and notarized before delivery to the Owner.

1.09 FINAL ADJUSTMENT OF ACCOUNTS

- A. Submit a final Statement of Accounting to the Owner.
- B. Statement shall reflect all adjustments to the Contract Sum:

1. The original Contract Sum.
2. Additions and deductions resulting from:
 - a. Previous Change Orders.
 - b. Allowances.
 - c. Unit Prices.
 - d. Deductions for uncorrected Work.
 - e. Deductions for liquidated damages.
 - f. Other adjustments.
3. Total Contract Sum, as adjusted.
4. Previous payments.
5. Sum remaining due.

C. The Owner will prepare a final Change Order reflecting approved adjustments to the Contract Sum, which was not previously made by Change Orders.

1.10 FINAL APPLICATION FOR PAYMENT

A. Contractor shall submit final Application for Payment in accordance with procedures and requirements stated in the Construction Contract and Section 01290, Payment Procedures of the Project Manual.

1.11 ADDITIONAL ADJUSTMENT

A. No adjustments to the Construction Contract requested by the Contractor will be allowed if asserted after execution of Final Payment of Contract.

1.12 POST-CONSTRUCTION INSPECTION

A. Prior to expiration of one (1) year from the Date of Final Completion, the Owner, or its designated representative, will make visual inspection of the Project Work in the company of the Contractor to determine whether further correction of Work is required in accordance with the provisions of the Construction Contract. The Contractor shall be responsible for contacting the Owner and scheduling and coordinating the one (1) year inspection.

B. The Owner will notify the Contractor, in writing, of any observed deficiencies.

C. Contractor shall contact the Owner to arrange convenient time and establish schedule for correction of deficiencies.

PART 2 – PRODUCTS

Not Used

PART 3 – EXECUTION

Not Used

END OF SECTION 01770

[REMAINDER OF PAGE INTENTIONALLY LEFT BLANK]

SECTION 01781

PROJECT RECORD DOCUMENTS

PART 1 – GENERAL

1.01 REQUIRED INCLUDED

- A. Contractor shall comply with and be responsible for all requirements of the Project Manual without exception.
- B. Contractor shall comply with the applicable requirements in this Section and more specific requirements in: Section 00800, Special Project Conditions; Section 01100, Summary of Work; Section 01330, Submittal Procedures; Section 01322, Photographic Documentation; and Section 01770, Close Out Procedures.
- C. Contractor shall conform to the requirements of the Owner, Georgetown County, and such other federal, state and municipal agencies having jurisdiction.

1.02 RELATED REQUIREMENTS

- A. Division 0, Bidding and Contract Documents, in the Project Manual without exception.
- B. Division 1, General Requirements in the Project Manual without exception.

1.03 MAINTENANCE OF DOCUMENTS AND SAMPLES

- A. For duration of Project, maintain at job Site the following:
 - 1. One copy of the Drawings, Technical Specifications, Addenda, shop drawings, products data, miscellaneous requested submittal data, Change Orders and other modifications to Contract, field orders, field test or written instructions.
 - 2. One copy of transmittal letters.
 - 3. One set of construction photographs.
 - 4. One set of samples.
 - 5. One copy of Permit Drawings as may be required by the appropriate governing agency having jurisdiction.
- B. Store documents and samples in Permit Box apart from documents used for construction.
- C. File documents and samples in accordance with CSI 16-division format.
- D. Maintain documents in a clean, dry, legible condition and in good order. Do not use record documents for construction purposes.
- E. Make documents and samples available at all times for inspection by the Owner.
- F. Incomplete or out of order documents and samples will be grounds for not approving the Design/Builder's Application for Payment.

- G. Provide felt tip marking pens for recording information in color code designated by the Owner.
- H. Label each document "PROJECT RECORD" in neat large printed letters. Keep record documents current. Record information concurrently with construction progress. Do not conceal any work until required information is recorded.

1.04 RECORD DRAWINGS

- A. Unless waived by the Owner, electronic data "As-Built" record drawings shall be required. The Owner will select electronic format and software to be used by Contractor.
- B. Permanent and Accurate Record Drawings shall be created on full size sheets (22 in. x 36 in. ft.) capable of being reproduced. These shall be made from the approved, original drawings, which shall be provided to a commercial reprographics service at an appropriate time. All of the aforementioned shall be at the Contractor's sole cost and expense.
- C. Legibly mark in color code designated by the Owner to record actual construction on designated Record Drawing prints:
 - 1. Depths of various elements of structure(s) foundations in relation to finish first floor datum.
 - 2. Horizontal and vertical locations of underground utilities and appurtenances referenced to permanent surface improvements.
 - 3. Location of all internal utilities and appurtenances and features of the structure(s), including dimensional locations of underground activities and other work
 - 4. Dimensional locations, vertical and horizontal, of site work, including utilities.
 - 5. Dimensional location, vertical and horizontal, of asphalt and concrete pavement.
 - 6. Dimensional location, vertical and horizontal, of storm water drainage system including pipe invert elevations.
- D. Indicate the following installed conditions:
 - 1. All electrical systems, plumbing and mechanical systems and such other units installed requiring periodic maintenance or repair.
 - 2. Equipment locations (exposed and concealed), dimensioned from prominent building lines.
 - 3. Approved substitutions, contract modifications, and actual equipment and materials installed.
 - 4. Field modifications with dimensions and details.
 - 5. Modifications made by addenda, clarifications, Field Orders or Change Orders.
 - 6. Details not on original, approved Construction Contract drawings.
 - 7. Record information on a daily basis, or as often as necessary.
 - 8. Include references to related shop drawings and modifications.
- E. Contractor shall retain competent drafting services, as necessary, for transfer of "mark-up notations" from information recorded during construction.
- F. Contractor shall submit Record Documents drawings to the Owner for review and acceptance thirty (30) days prior to final closeout.
- G. Make revisions and additions as may be indicated by the Owner.
- H. Do not use these Drawings for reference or construction, nor allow them to leave the field office.

1.05 RECORD SPECIFICATIONS AND ADDENDA

- A. Legibly mark up in color code designated by the Owner each Specification Section to record the following:
 - 1. Manufacturer, trade name, catalog name and supplier (with address and phone number) of each product and item of equipment actually installed.
 - 2. Modifications made by Change Order.
 - 3. Other matters not originally specified.

1.06 RECORD SAMPLES

- A. Record in transmittal, if not indicated, manufacturer, trade name, catalog number.

1.07 SUBMITALLS

- A. At Contract closeout, Contractor shall sign each final Record Drawing and cover of Record Specifications stating documents are complete and accurate, deliver project Record Documents to the Owner.
- B. Accompany submittal with transmittal letter in duplicate, containing:
 - 1. Date.
 - 2. Owner RFP / Bid Number.
 - 3. Contractor's name and address.
 - 4. Title and number of each Record Document.
 - 5. Signature of Contractor or his/her authorized representative.
- C. Submit the following quantities of Record Documents:
 - 1. Two (2) complete and full sets of Project Record Drawings.
 - 2. Two (2) complete sets of "Up-Dated" Technical Specifications
 - 3. A complete set of Project Record Drawings in electronic format to be determined by Owner.

1.08 BURDEN OF ACCURACY

- A. Contractor shall bear all costs of damages of any nature incurred by the Owner due to inaccuracies or incompleteness of the submitted Project Record Documents.

PART 2 – PRODUCTS

Not Used

PART 3 – EXECUTION

Not Used

END OF SECTION 01781

[REMAINDER OF PAGE INTENTIONALLY LEFT BLANK]

SECTION 01790

WARRANTIES AND BONDS

PART 1 - GENERAL

1.01 RELATED REQUIREMENTS

- A. Division 0, Bidding and Contract Documents of the Project Manual without exception.
- B. Division 1, General Requirements of the Project Manual without exception.
- C. Approved Technical Specifications as applicable and required.

1.02 SUMMARY

- A. This Section specifies general administrative and procedural requirements for warranties and bonds required by the Construction Contract Documents, including manufacturer's standard warranties on products and special warranties.
 - 1. Refer to the applicable requirements of Division 0 and Division 1 for Contractor's special warranty of workmanship and materials.
 - 2. General closeout requirements are included in Section 01770, Closeout Procedures.
 - 3. Specific requirements for warranties for the Work and products and installations that are specified to be warranted, are included in the individual and applicable Sections of the Technical Specifications.
 - 4. Certifications and other commitments and agreements for continuing services to the Owner, Georgetown County, South Carolina are specified elsewhere in the Construction Contract Documents.
- B. Disclaimers and Limitations: Manufacturer's disclaimers and limitations on product warranties do not relieve the Contractor of the warranty on the Work that incorporates the products.

1.03 WARRANTY REQUIREMENTS

- A. Related Damages and Losses: When correcting warranted Work that has failed, remove and replace other Work that has been damaged as a result of such failure or that must be removed and replaced to provide access for correction of warranted Work.
- B. Reinstatement of Warranty: When Work covered by a warranty has failed and been corrected by replacement or rebuilding, reinstate the warranty by written endorsement. The reinstated warranty shall be equal to the original warranty with an equitable adjustment for depreciation.
- C. Replacement Cost: Upon determination that Work covered by a warranty has failed, replace or rebuild the Work to an acceptable condition complying with requirements of the Construction Contract Documents. The Contractor is responsible for the cost of replacing or rebuilding defective Work regardless of whether the Owner has benefited from use of the Work through a portion of its anticipated useful service life.
- D. Owner Recourse: Written warranties made to the Owner are in addition to implied warranties, and shall not limit the duties, obligations, rights and remedies otherwise available under the law, nor shall warranty periods be interpreted as limitations on time in which the Owner can enforce such other duties, obligations, rights, or remedies.
- E. Rejection of Warranties: The Owner reserves the right to reject warranties and to limit selections to products with warranties not in conflict with requirements of the Construction Contract Documents.

- F. The Owner reserves the right to refuse to accept Work for the Project where a special warranty, certification, or similar commitment is required on such Work or part of the Work, until evidence is presented that entities required to counter sign such commitments are willing to do so.

1.04 SUBMITTALS

- A Submit written warranties to the Owner prior to the date certified for Substantial Completion. If the Certificate of Substantial Completion designates a commencement date for warranties other than the date of Substantial Completion for the Work, or a designated portion of the Work, submit written warranties upon request of the Owner.
- B When a designated portion of the Work is completed and occupied or used by the Owner by separate agreement with the Contractor during the construction period, submit properly executed warranties to the Owner within ten (10) calendar days of completion of that designated portion of the Work.
- C When a special warranty is required to be executed by the Contractor, or the prime and a subcontractor, supplier or manufacturer prepare a written document that contains appropriate terms and identification, ready for execution by the required parties, Contractor shall submit a draft to the Owner for approval prior to final execution.
- D Form of Submittal: At Final Completion, the Contractor shall compile two (2) copies of each required warranty and bond properly executed by the Contractor, or by the prime, subcontractor, supplier, or manufacturer. Organize the warranty documents into an orderly sequence based on the table of contents of the Project Manual.
- E Bind warranties and bonds in heavy-duty, commercial quality, durable 3-ring vinyl covered loose-leaf binders, thickness as necessary to accommodate contents, and sized to receive 8-1/2" by 11" paper.
- F Provide heavy paper dividers with celluloid covered tabs for each separate warranty. Mark the tab to identify the product or installation. Provide a typed description of the product or installation, including the name of the product, and the name, address and telephone number of the installer.
- G Identify each binder on the front and the spine with the typed or printed title "WARRANTIES AND BONDS, the Project title or name and location, Owner RFP / Bid number and the name of the Contractor.
- H When operating and maintenance manuals are required for warranted construction, provide additional copies of each required warranty, as necessary, for inclusion in each required manual.

PART 2 - PRODUCTS

Not Used

PART 3 - EXECUTION

Not Used

END OF SECTION 01790

END OF VOLUME 1

VOLUME II - PROJECT MANUAL

SPECIAL PROVISIONS

JOB NUMBER

171002426

Bid NUMBER

Bid #22-048

COUNTY

Georgetown

This project is to be constructed under the South Carolina Department of Transportation's Specifications for Highway Construction Edition of 2007, the Supplemental Technical Specifications in effect as of October 2022 or as referenced in these Special Provisions, and the following Special Provisions.

*The Contractor is hereby advised that the construction of Bid #22-048 will be managed by Georgetown County.

(1) REFERENCES:

For purposes of this Contract references to the Department shall refer to the Georgetown County Department of Public Services. References to the "Resident Construction Engineer", "Director of Traffic Engineering" or "Engineer's Representative" shall refer to **Georgetown County**.

(2) STANDARDS AND REFERENCES:

This project is to be constructed under the SCDOT 2007 Standard Specifications for Highway Construction, the current SCDOT Standard Drawings as of October 2015, the SCDOT Supplemental Technical Specifications in effect at the time of the letting, and the following Special Provisions:

The above noted publications are available on the internet as follows, or may be obtained from the SCDOT Engineering Publications office at (803) 737-4533 or via e-mail at engrpubsales@dot.state.sc.us

SCDOT 2007 Standard Specifications for Highway Construction	http://www.scdot.org/doing/const_man.shtml
2009 SCDOT Standard Drawings	http://www.scdot.org/doing/sd_disclaimer.shtml
SCDOT Supplemental Technical Specifications	http://www.scdot.org/doing/sup_tech_specs.shtml

(3) ERRATA TO 2007 STANDARD SPECIFICATIONS FOR HIGHWAY CONSTRUCTION:

See attached Supplemental Specification dated **May 4, 2009**.

(4) FAIR LABOR STANDARDS ACT OF 1938, AS AMENDED:

Attention is directed to this Federal Legislation which has been enacted into law. The contractor will be responsible for carrying out all of the provisions of this legislation which may affect this contract.

(5) MANUFACTURERS MATERIALS CERTIFICATIONS AND CERTIFIED TEST REPORTS:

The contractor shall supply the Resident Engineer with all required materials certifications and manufacturers test reports for items to be permanently incorporated into the project. These material certifications shall be provided prior to the materials use in the project. The County Project Manager must approve these certifications and reports before the contractor may install these materials.

(6) SECTION 101: STANDARD DRAWINGS:

The 2021 SCDOT Standard Drawings are effective beginning with the January 2021 letting. These drawings are available for download at <https://www.scdot.org/business/standard-drawings.aspx> or for purchase through the SCDOT Engineering Publications Sales Center. The Engineering Publication Sales Center is located in Room G-19 (basement level) of the SCDOT Headquarters Building, 955 Park Street, Columbia, South Carolina.

All references in the plans, standard specifications, supplemental specifications, supplemental technical specifications or special provisions to drawings under the previous numbering system are hereby updated to the new drawing numbers. Refer to sheets 000-205-01 through 000-205-07 to find new drawing numbers when looking for references to older drawing numbers.

(7) SECTION 106: QUALIFIED PRODUCT LISTINGS:

All references to "Approval Sheet" or "Approval Policy" are to be replaced with "Qualified Products Listing (QPL)" and Qualified products Policies (QPP)" respectively. This change includes all references in the SCDOT Standard Drawings, SCDOT Standard Specifications, SCDOT Supplemental Specifications, SCDOT Special Provisions, SCDOT Supplemental Technical Specifications, SCDOT Internet and Intranet websites, and all other documents produced by SCDOT.

(8) SECTION 108 (PROSECUTION AND PROGRESS)

Section 108.9 (Failure to Complete the Work on Time)

Delete Section 108.9 in its entirety and substitute the following in its place:

"County and Contractor recognize that time is of the essence and that the traveling public and Department will suffer loss, inconvenience and other damage if the work is not substantially complete in accordance with the time(s) specified herein, which damages would be difficult if not impossible to ascertain. Accordingly, the County and the Contractor agree that as liquidated damages for delay (but not as a penalty) the Contractor shall pay the County the amounts stipulated below.

LIQUIDATED DAMAGES SCHEDULE

<i>Liquidated Damages</i>	
<i>\$500</i>	<i>Per Day</i>

Contractor further agrees that in addition to the liquidated damages specified above, the Contractor shall pay the County the actual costs to County for any inspector or inspectors necessarily employed by County on the work and the actual costs to County for the Engineer's observation of construction and project representative services, including all travel and subsistence expenses after the date specified for Project completion until the work is completed and ready for final payment.

(9) SECTION 106: SOUTH CAROLINA MINING ACT:

See attached Supplemental Specification dated **March 20, 2003**.

This Supplemental Specification is hereby modified as follows:

Paragraph 9 is hereby deleted and replaced with the following:

The deputy secretary for engineering, or his duly appointed representative, will make a final inspection of the reclaimed area and keep a permanent record of his approval thereof. A map or sketch providing the location and approximate acreage of each pit used on the project will be provided to the resident construction engineer for inclusion in the final plans.

The last paragraph is hereby deleted and replaced with the following:

The contractor shall comply with the provisions of the plan that are applicable to the project as determined by the engineer. Seeding or other work necessary to comply with the plan on pits

furnished by the Contractor shall be at the expense of the Contractor. Seeding shall be in accordance with SC-M-810 (latest version) which can be found at http://scdot.org/doing/sup_tech_specs.shtml.

(10) SECTION 103.8 CONTRACTOR’S LIABILITY INSURANCE:

Section 103.8 is hereby deleted and replaced with the requirements of **SECTION 00100, Item #29 of this Project Manual Bid #19-036.**

(11) SECTION 105: CONSTRUCTION STAKES, LINES AND GRADES:

Section 105.8.2 applies to this project. Partial Payments for this work shall be made according to the following chart and the approved schedule of values:

Percent Contract Complete	Percent of Stakes, Lines, and Grades bid amount to be paid
1-5	20
6-15	40
16-29	60
30-49	70
50-69	80
70-89	90
90-100	100

(12) SECTION 107: COORDINATION OF UTILITY RELOCATION WORK WITH ROAD CONSTRUCTION:

As it is not economically feasible to complete the rearrangement of all utility conflicts in advance of the highway construction, such rearrangements may be underway concurrently with construction.

It shall be the responsibility of the contractor to inspect the site for potential utility conflicts. Contractor shall understand utilities servicing roads affected by construction. Contractor shall verify with affected utilities their receipt of construction plans and in absence thereof, facilitate the distribution of plans. ***Contractor shall also coordinate with the Utilities to schedule and complete relocations that are required but not performed prior to the notice to proceed for the project.***

It is the responsibility of the Contractor to call Palmetto Utility Protection Service (1-888-721-7877) three (3) days prior to work so that existing utilities can be properly marked.

(13) CONTRACTOR ACTIVITY WORK SCHEDULE AND SCHEDULE OF VALUES:

The contractor shall furnish a construction schedule for each road to be improved under this contract. This schedule shall be in a bar graph format and sufficiently detailed to indicate the type of work to be done and the duration of each operation.

In addition, the contractor shall furnish Georgetown County with a written activity schedule of his work for 4 week periods, with the schedules being updated each 2 weeks. The schedule shall show the scheduled work activity for each week.

The purpose of the above schedule is to provide the County with adequate advance information in order that he may schedule his personnel so as to provide construction engineering and inspection. In the event the contractor does not proceed by his schedule, then the County will not be responsible for delays to the contractor which may be caused by his failure to abide by his schedule.

The Contractor shall provide a schedule of values showing a breakdown of the contract sum for the various operations that will be accomplished as a part of this work. This schedule of values will determine the amount of the partial payments made to the Contractor for each month’s work. The values placed upon this schedule will be used only for determining the basis of partial payments and will not be considered as fixing

a basis for additions to or deductions from the contract price. The schedule of values shall be submitted to the County not less than 10 days prior to making an application for partial payment in a form that is acceptable to the County.

(14) LUMP SUM BID:

The **lump sum bid** for the construction of this project shall include but not be limited to clearing and grubbing of roadway, erosion control, proof rolling existing subgrade, all borrow excavation, all unclassified excavation, all drainage pipes including excavation and installation, fine grading, stabilized aggregate base course, asphalt surface course, pavement markings, signs, traffic control, quality control, and temporary and permanent grassing, and all other items required to complete the roads per the plans. The lump sum price shall include the cost of all materials, labor, equipment, overhead and profit as necessary to construct the project in accordance with the plans, the specifications and these special provisions with the exception of any unit price items that may be included on the bid form.

Additional payment maybe made for Maintenance Stone as described in Special Provision #25 of this document per the unit prices provided in Section 00300.

Additional payment may also be made for Muck Excavation if prior approval is granted from the County. See Special Provision #36 for details.

This Special Provision #14 shall supersede any other method of payment described in the SCDOT References listed in Special Provision #2 of this document or any other Special Provisions contained in this document with the exception of Special Provision #44.

(15) NOTICE TO PROCEED:

Unless otherwise specified in these documents, Section 108.2 is hereby revised to include the following:

A Notice to Proceed Date shall be determined at the Preconstruction Conference that will be held within thirty (30) calendar days of the Award Date. The Notice to Proceed Date shall not be more that forty-five (45) calendar days after the Date of Award unless extenuating circumstances such as utility conflicts occur which are beyond the control of the Contractor as determined by the County.

(16) SECTION 107: CONTRACT PROVISIONS TO REQUIRE CERTIFICATION AND COMPLIANCE CONCERNING ILLEGAL ALIENS

By submission of this bid, the bidder as the prime contractor does hereby agree:

- a. to certify its compliance with the requirements of Chapter 14 of Title 8 of the S.C. Code of Laws regarding Unauthorized Aliens and Public Employments;
- b. to provide SCDOT with any documents required to establish such compliance upon request; and
- c. to register and participate and require agreement from subcontractors and sub-subcontractors to register and participate in the federal work authorization program to verify the employment authorization of all new employees, or to employ only worker who supply the documents required pursuant to S.C. Code 8-14-20(B)(2).

(17) SECTION 109: RETAINAGE

There will be a 10% RETAINAGE held by the County until all work is complete in a satisfactory manner.

(18) SUBLETTING OF CONTRACTS (SPECIALTY ITEMS);

The following items of work, when not performed by the Prime Contractor, will be designated as Specialty Items in all contracts in which the item does not constitute thirty percent (30%) or more of the original contract value:

Guardrail
Milling Asphalt Pavement
Grassing
Landscaping
Erosion Control
Permanent Construction Signs
Utilities
Contaminated Soil & Tank Removal
Bridge Barrier Walls
Traffic Count Stations
Drilled Shafts & Casings
Pier Fender Systems

Signalization
Electrical/Lighting
Specialized Retaining Walls
Fencing
Right of Way Surveying
Railroad Track Work
Jacking and Boring
Bridge Floor Grooving
Milled Rumble Strips
Buildings
Navigational Lighting
Sound Barrier Walls

- (19) CONTRACT TIME AND DETERMINATION AND EXTENSION OF CONTRACT TIME:**
Completion date for this project is **150 Days from Notice to Proceed**. See section 0075 for additional details.

- (20) MAINTENANCE OF TRAFFIC:**
In addition to the Contractor maintaining traffic throughout the length of this project as required by the Specification, it will also be necessary that the Contractor, prior to beginning any work, submit to the Resident Construction Engineer for approval his plan for constructing these projects.

- (21) REQUIRED MEDIA NOTIFICATION FOR CONSTRUCTION PROJECTS:**
Contractors are encouraged to cooperate with the news media since all projects are constructed with public funds. Because the scope of this project will cause disruption of normal traffic flow, the contractor is required to notify the public, in a timely manner, of disruptive activities such as lane closures.

The Contractor is required to utilize area media to accomplish public notification of traffic disruptions.

The Contractor is required to deal directly with the news media and all reasonable efforts should be made to cooperate with the media. However, the safety, security and construction schedule on site should not be disrupted in order to accomplish this.

- (22) DIVISION 600: MANUAL ON UNIFORM TRAFFIC CONTROL DEVICES:**
“The Contractor is hereby advised that the Department has adopted the MUTCD 2003-Manual on Uniform Traffic Control Devices for use on all projects. All References to the South Carolina Manual on Uniform Traffic Control Devices (SCMUTCD) are hereby revised to read “MUTCD – 2003 Edition”.

- (23) DIVISION 600: TRAFFIC CONTROL**
The Contractor shall execute the item of Traffic Control as required by the Standard Specifications, the plans, the Standard Drawings For Road Construction, these special provisions, all supplemental specifications, the MUTCD, and the Engineer. This is an amendment to the Standard Specifications to require the following:

GENERAL REGULATIONS -

These special provisions shall have priority to the plans and comply with the requirements of the MUTCD and the standard specifications. Revisions to the traffic control plan through modifications of the special provisions and the plans shall require approval by the County or SCDOT where appropriate. **Final approval of any revisions to the traffic control plan shall be pending upon review by Georgetown County or SCDOT where applicable.**

Due to the residential characteristics of these roads, Georgetown County reserves the right to restrict work on and around County recognized holidays, such as but not limited to Thanksgiving, Christmas, and Easter.

Install and utilize changeable message signs in all lane closures installed on high volume high-speed multilane roadways. Use of changeable message signs in lane closures installed on low volume low speed multilane roadways is optional unless otherwise directed by the plans and the Engineer. Install and use a changeable message sign within a lane closure set-up as directed by the *Standard Drawings For Road Construction*. When a lane closure is not present for any time to exceed 24 hours, remove the changeable message sign from the roadway. Place the sign in a predetermined area on the project site, as approved by the Engineer, where the sign is not visible to passing motorists. Utilize preprogrammed messages in accordance with the *Standard Drawings for Road Construction* when using the changeable message sign as part of the traffic control set-up for lane closures. Only those messages pertinent to the requirements of the traffic control situation and the traffic conditions are permitted for display on a changeable message sign at all times. At no time will the messages displayed on a changeable message sign duplicate the legends on the permanent construction signs.

During operation of changeable message signs, place the changeable message sign on the shoulder of the roadway no closer than 6 feet between the sign and the near edge of the adjacent travel lane. When the sign location is within 30' of the near edge of a travel lane open to traffic, supplement the sign location with no less than 5 portable plastic drums placed between the sign and the adjacent travel lane for delineation of the sign location. Install and maintain the drums no closer than 3 feet from the near edge of the adjacent travel lane. This requirement for delineation of the sign location shall apply during all times the sign location is within 30' of the near edge of a travel lane open to traffic, including times of operation and non-operation. Oversized cones are prohibited as a substitute for the portable plastic drums during this application.

All signs mounted on portable sign supports shall have a minimum mounting height of 5' from the ground to the bottom of the sign. All signs mounted on ground mounted u-channel posts shall have a minimum mounting height of 7' from the ground to the bottom of the sign.

When covering signs with opaque materials, the Department prohibits attaching a covering material to the face of the sign with tape or a similar product or any method that will leave a residue on the retroreflective sheeting. Residue from tape or similar products, as well as many methods utilized to remove such residue, damages the effective reflectivity of the sign. Therefore, contact of tape or a similar product with the retroreflective sheeting will require replacement of the sign. Cost for replacement as a sign damaged by improper covering methods will be considered incidental to providing and maintaining the sign; no additional payment will be made.

Signs not illustrated on the typical traffic control standard drawings designated for permanent construction signs shall be considered temporary and shall be included in the lump sum price bid item for "Traffic Control" unless otherwise specified.

Install and maintain any necessary detour signing as specified by the typical traffic control standard drawings designated for detour signing, Part VI of the MUTCD, these Special Provisions, and the Engineer. The lump sum price bid item for "Traffic Control" includes payment for installation and maintenance of the detour signing.

The Contractor shall maintain the travel patterns as directed by the traffic control plans and shall execute construction schedules expeditiously. The Contractor shall provide the Resident Engineer with no less than a two-week prior notification of changes in traffic patterns.

During nighttime flagging operations, flaggers shall wear a safety vest and safety pants that comply with the requirements of ANSI / ISEA 107-2004 standard performance for Class 3 risk exposure or latest revisions and a fluorescent hard hat. The safety vest and the safety pants shall be retroreflectORIZED and the color of the background material of the safety vest and safety pants shall be fluorescent orange-red. Night time work shall be prohibited in residential areas.

During nighttime flagging operations, the contractor shall illuminate each flagger station with any combination of portable lights, standard electric lights, existing street lights, etc., that will provide a minimum illumination level of 108 Lx or 10 fc.

During nighttime flagging operations, supplement the array of advance warning signs with a changeable message sign for each approach. These changeable message signs are not required

during daytime flagging operations. Install the changeable message signs 500' in advance of the advance warning sign arrays. Messages should be "Flagger Ahead" and "Prepare to Stop".

The Contractor shall maintain local traffic on the Road during construction.

ADDENDUMS

Traffic Control Pay Items
(Addendums to the "2007 Standard Specifications for Highway Construction")

(A) Trailer Mounted Changeable Message Signs –

Sub-section 606.5 Measurement (paragraph 2) –

Trailer-mounted changeable message signs are included in the lump sum item for Traffic Control in accordance with **Subsections 107.12** and **601.5** of the "2007 Standard Specifications for Highway Construction". No separate measurement will be made for trailer-mounted changeable message signs unless the contract includes a specific pay item for trailer-mounted changeable message signs.

The Contractor shall provide, install, operate, and maintain the trailer-mounted changeable message sign per traffic control set-up as directed by the Plans, the "Standard Drawings for Road Construction", these Special Provisions, the Specifications, and the Engineer.

Sub-section 606.6 Payment (paragraph 2) –

In addition to **Subsections 107.12** and **601.6**, the payment for Traffic Control is full compensation for providing, installing, removing, relocating, operating, and maintaining trailer-mounted advance warning arrow panels and trailer-mounted changeable message signs as specified or directed and includes providing the units' primary power source; repairing or replacing damaged or malfunctioning units within the specified time; providing traffic control necessary for installing, operating, and maintaining the units; and all other materials, labor, hardware, equipment, tools, supplies, transportation, incidentals, and any miscellaneous items necessary to fulfill the requirements of the pay item in accordance with the Plans, the Specifications, and other items of the Contract.

Sub-section 606.6 Payment (paragraph 3) –

Disregard this paragraph unless the Contract includes a specific pay item for trailer-mounted changeable message signs.

TYPICAL TRAFFIC CONTROL STANDARD DRAWINGS -

The typical traffic control standard drawings of the "Standard Drawings for Road Construction", although compliant with the MUTCD, shall take precedence over the MUTCD. The typical traffic control standard drawings of the "Standard Drawings for Road Construction" shall apply to all projects let to contract.

Install the permanent construction signs as shown on the typical traffic control standard drawings designated for permanent construction signing. The schemes shown below are recommended but may be varied by the County or SCDOT to meet field conditions.

Road	Scheme	Intersecting Roads	Total (SF)
Plover Drive	C	2 on Pennyroyal Rd.	152

(25) MAINTENANCE STONE:

Maintenance Stone used on this project shall conform to the gradation requirements of Section 305, or to the gradation specified for Aggregate No. CR-14 in the Standard Specifications.

(26) SECTION 305: GRADED AGGREGATE BASE COURSE:

Only one type of Graded Aggregate Base Course is to be selected. The Contractor is to indicate on the attached for on page 68 which type has been selected for use on this project. This form is to be submitted to the Resident Construction Engineer at the Preconstruction Conference.

(27) SECTION 401: ASPHALT BINDER ADJUSTMENT INDEX:

Because the base bid of this project is Lump Sum, an Asphalt Binder Adjustment is **NOT** included for this project.

(28) PAVING OF DRIVEWAYS:

All earth driveways shall be surfaced as a part of this contract. Quantities for the surfacing of driveways are considered as being paved to the right-of-way line.

(29) BORROW EXCAVATION:

Borrow pit location – Borrow material for this project shall not be obtained from wetlands, streams, or rivers.

(30) SECTION 714: SUPPLEMENTAL TECHNICAL SPECIFICATION SC-M-714:

Supplemental Technical Specification SC-M-714 shall apply to this project as it pertains to Reinforced Concrete Pipe with the following exceptions.

Upon prior written approval from the County, existing soil may be used as backfill from driveway pipes. If existing soil is used, each 8" lift shall be compacted and approved by Georgetown County prior to proceeding with the next lift. Pipes crossing the roadway shall be backfilled with material meeting the requirements of SC-M-714.

Section 1.3.10 Installation Inspection (RCP) subsection Post Construction (Acceptance) shall be deleted. No video inspection or laser profiler/Deflectometer testing will be required on this project.

(31) SECTION 810: SEEDING:

SCDOT Supplement Technical Specification SC-M-810 or SC-M-810-2 shall not apply to this contract. Seeding shall be installed, measured, and paid for in accordance with **Section 810** of the **2007 Standard Specifications for Highway Construction**.

(32) SEEDING AND EROSION CONTROL MEASURES:

In addition to all the erosion control measures specified in the Standard Specifications, the plans and these Special Provisions, the Contractor shall construct all erosion control devices promptly as directed by the Engineer. Seeding of all disturbed areas shall be carried out as the grading progresses.

Failure of the Contractor to comply promptly and adequately with all the required erosion control measures and seeding will result in stopping all contract operations until corrective action has been taken.

(33) GEOTEXTILE FOR DRAINAGE FILTRATION

If #57 Stone Bedding is required by the Engineer, then this fabric shall be used to wrap the stone bedding. See attached Supplemental Specification.

(34) ROLLED EROSION CONTROL PRODUCTS (ECB'S & TRM'S)

Erosion Control Blankets (ECB's) and Turf Reinforcement Mats (TRM's) shall meet the requirements SCDOT Technical Specification **SC-M-815-09 dated April 4, 2011 (see Special Provision #2)**. Use of these products is specified in the OCRM/DHEC Land Disturbance permit so no substitutions will be allowed and failure to install these products per the plans and specified requirements will be a violation of the permit.

(35) HYDRAULIC EROSION CONTROL PRODUCTS (HECP)

These products shall meet the requirements SCDOT Technical Specification **SC-M-815-11 dated April 4, 2011 (see Special Provision #2)**. Use of these products is specified in the OCRM/DHEC Land Disturbance permit so no substitutions will be allowed and failure to install these products per the plans and specified requirements will be a violation of the permit.

(36) MUCKING EXCAVATION

Any unsuitable material within 2' horizontal feet of pavement limits. Mucking will be paid for by the cubic yard, 12" below existing ground outside of the existing gravel roadway. Material removed less than 12" in depth will be considered "stripping" and shall be included in the lump sum bid.

The unit price bid for mucking excavation, if required, shall include removing and disposing of unsuitable material that is more than 12" below existing ground, **and replacing the material with borrow material meeting the SCDOT specifications** and providing compaction in accordance with the SCDOT Specifications. This quantity shall be paid per CY and calculated by x,y,z field measurements agreed upon by both Georgetown County and the Contractor. The quantity shall be agreed upon prior to the placement of any fill in the mucked area. Once the area is filled, no additional claim above the CY agreed upon will be allowed.

As stated above, excavation of less than 12" shall be considered "Stripping." Stripping of the top soils or other existing material as required up to 12" shall be considered part of the base lump sum bid as described in Special Provision #14 of this Contracts' Technical Specifications.

(37) ROADWAY CONSTRUCTION WITHIN SCDOT RIGHT-OF-WAY

The roadway apron that ties to a SCDOT Roadway shall be installed as specified by the note on the typical section. The apron shall end at a perpendicular line at the radius return termini farthest from the SCDOT roadway. **The joint against the SCDOT Roadway asphalt shall be a saw cut joint.**

(38) UTILITY ALLOWANCE

A Utility Allowance is included in the contract for work on Plover Drive, not covered in the quantities provided by Georgetown County Water and Sewer. See last page of the Supplemental Specifications for details.

END OF SPECIAL PROVISIONS

SECTION D – SUPPLEMENTAL SPECIFICATIONS

ERRATA TO 2007 STANDARD SPECIFICATIONS FOR HIGHWAY CONSTRUCTION

Make the changes listed below to correct errata in the SCDOT *2007 Standard Specifications for Highway Construction*:

DIVISION 100 GENERAL PROVISIONS

SECTION 101 DEFINITIONS AND TERMS

Subsection 101.2 Abbreviations and Acronyms

Amend the table of **SCDOT OFFICIALS AND OFFICES** as follows:

BDE*	Bridge Design Engineer	PSE*	Preconstruction Support Engineer
BDGE*	Bridge Design Geotechnical Engineer	GDSE*	Geotechnical Design Support Engineer
SHE*	State Highway Engineer	DSE*	Deputy Secretary for Engineer

*Wherever it appears in the text, replace the deleted abbreviation with the new abbreviation.

SECTION 102 BIDDING REQUIREMENTS AND CONDITIONS

Subsection 102.8 Irregular Bids

Paragraph 2, item E, first sentence; delete the word “the” after the word “When”.

SECTION 105 CONTROL OF WORK

Subsection 105.6 Cooperation with Utilities

Paragraph 1, last sentence; change the word “THE” to “the”.

DIVISION 200 EARTHWORK

SECTION 202 REMOVAL OF STRUCTURES AND OBSTRUCTIONS

Subsection 202.5 Measurement

Paragraph 5, second bullet; change the words “Brick sidewalk” to Concrete, brick or stone sidewalks”.

SECTION 204 STRUCTURE EXCAVATION

Subsection 204.2.1.2 Structure Excavation for Culverts

Paragraph 1, at the end of the first sentence; change “**Subsection 2.4.4**” to “**Subsection 2.4.5**”.

DIVISION 400 ASPHALT PAVEMENTS

SECTION 401 HOT MIXED ASPHALT (HMA) PAVEMENT

Subsection 401.2.1.2 Liquid Anti-Stripping Agent

Paragraph 1, first sentence; delete the period at the end of the sentence and add “and SC-M-406.”.

Subsection 401.2.5 Material for Full Depth Patching

Paragraph 1, delete and replace with the following:

“Use an approved SCDOT Intermediate Type C mix for all Full Depth Patching.”

Subsection 401.5 Measurement

After paragraph 10, add the following paragraph:

- 11 The measurement of Prime Coat is the number of gallons of asphalt material applied to the completed and accepted base course.

Subsection 401.6 Payment

After paragraph 12, add the following paragraph:

- 13 “The payment for Prime Coat is at the contract unit price for Prime Coat and includes compensation for all labor, equipment, tools, maintenance, and incidentals necessary to complete that work.”

Subsection 401.6 Payment

Paragraph 13, **Table of Pay Items**

Change paragraph reference number “13” to “14” and add the following Pay Item:

Item No.	Pay Item	Unit
4010005	Prime Coat	GAL

SECTION 403 HMA SURFACE COURSE

Subsection 403.5 Measurement

Paragraph 1, first sentence; change “HMA Intermediate Course” to “HMA Surface Course”.

Subsection 403.6 Payment

Paragraph 1, first sentence; change “HMA Intermediate Course” to “HMA Surface Course”.

SECTION 407 ASPHALT SURFACE TREATMENT – DOUBLE TREATMENT

Subsection 407.5 Measurement

Paragraph 1, first sentence; add the word “is” after “(Double Treatment Type (1, 2, 3, 4, or 5))”.

SECTION 408 ASPHALT SURFACE TREATMENT – TRIPLE TREATMENT

Subsection 408.5 Measurement

Paragraph 1, first sentence; add the word “is” after “(Triple Treatment Type (1 or 2))”.

DIVISION 600 MAINTENANCE AND TRAFFIC CONTROL

**SECTION 625 PERMANENT PAVEMENT MARKINGS
FAST DRY WATERBOURNE PAINT**

Subsection 625.2.2.4.11 Lead Content

Paragraph 1, first sentence; change 6% to 0.06%.

SECTION 627 THERMOPLASTIC PAVEMENT MARKINGS

Subsection 627.4.10 Inspection and Acceptance of Work

Paragraph 2, first sentence; change “period of 90 days” to “period of 180 days”.

Subsection 627.4.10 Inspection and Acceptance of Work

Paragraph 2, second sentence; change “90-day observation period” to “180-day observation period”.

Subsection 627.4.10 Inspection and Acceptance of Work

Paragraph 3, first sentence; change “90-day period” to “180-day period”.

DIVISION 700 STRUCTURES

SECTION 709 STRUCTURAL STEEL

Subsection 709.4.3.5.2 Submittals and Notification

Paragraph 1, delete the last two sentences and replace them with, "The Department's review and acceptance are required before any field welding will be permitted."

Subsection 709.6.3 Pay Items (page 650)

Subsection heading number; change subsection heading number from "709.6.3" to "709.6.4".

SECTION 712 DRILLED SHAFTS AND DRILLED PILE FOUNDATIONS

Subsection 712.4.4 Dry Construction Method

Paragraph 2, last sentence in A; change "*Drilled Shaft Report*" to "*Drilled Shaft Log*".

Subsection 712.4.10.4 Excavation Cleanliness

Paragraph 1, last sentence; change "*Drilled Shaft Report*" to "*Drilled Shaft Log*".

Subsection 712.4.10.6 Shaft Load Test

Change first paragraph reference number from "2" to "1".

Subsection 712.6.10 Drilled Pile Set-Up

Insert paragraph reference number "1" to the left of the first paragraph.

SECTION 723 DECK JOINT STRIP SEAL

Subsection 723.1 Description

Insert paragraph reference number "3" to the left of the third paragraph.

SECTION 726 BRIDGE DECK REHABILITATION

Subsection 726.4.1 General

Insert paragraph reference number "1" to the left of the first paragraph.

Subsection 723.4.6 Full Depth Patching (page 790)

Subsection heading number; change subsection heading number from "723.4.6" to "726.4.6".

SECTION 727 CROSSHOLE SONIC LOGGING OF DRILLED SHAFT FOUNDATIONS

Subsection 726.6 Payment (page 807)

Subsection heading number; change subsection heading number from "726.6" to "727.6".

DIVISION 800 INCIDENTAL CONSTRUCTION

SECTION 805 GUARDRAIL

Subsection 805.5 Measurement

Paragraph 4; amend as follows:

"The quantity for the pay item 8053000 Additional Length Guardrail Post is the length of required post installed in excess of the standard length post based on the system being installed, measured by the linear foot (LF), complete, and accepted."

SECTION 815 EROSION CONTROL

Subsection 815.1 Description

Paragraph 1, first sentence; change "temporary flexible pipe" to "temporary pipe".

Subsection 815.5 Measurement

Paragraph 13; delete the first sentence and replace it with the following sentence of 150

“The quantity for Temporary Pipe Slope Drains is measured and paid for in accordance with **Subsection 803.5** and **803.6** respectively.”

Subsection 815.5 Measurement

Delete paragraph 19.

Subsection 815.6 Payment

After paragraph 15, add the following paragraph:

- 16 Payment for Removal of Silt Retained by Silt Fence is full compensation for removing and disposing of sediment deposits accumulated by silt fences as specified or directed and includes all materials, labor, equipment, tools, supplies, transportation, and incidentals necessary to fulfill the requirements of the pay item in accordance with the Plans, the Specifications, and other terms of the Contract.

Subsection 815.6 Payment

Change original paragraph number “16” to “17”.

Subsection 815.6 Payment

Pay Item table; change the Unit for Item No. 8156214 to “EA”.

INDEX:

Amend as follows:

Page I-3, after “Bridge Deck Rehabilitation, measurement and payment:”
Delete page 807.

Page I-12, after “Letting:”
Replace page 19 with page 9.

Page I-13, after “Overhead Sign Structure:”
Replace page 488 with page 495.

Page I-15, after “Proof Rolling:”
Delete page 98.

Page I-18, after “Structural Steel, turned and ribbed bolts:”
Replace page 624 with page 625.

Page I-19, after “Waterproofing, bridge deck:”
Delete page 907.

Page I-20, after “Working Drawings:”
Replace page 543 with page 779.

[THE REMAINDER OF THIS PAGE IS INTENTIONALLY LEFT BLANK.]

March 20, 2003

THE SOUTH CAROLINA MINING ACT

The South Carolina Mining Act enacted by the General Assembly in 1973 requires that the Department adopt reclamation standards to govern activities of the Department and any person acting under contract with the Department, on highway rights-of-way or material pits maintained solely in connection with the construction, repair and maintenance of the public road systems in South Carolina.

**STANDARD PLAN FOR THE RECLAMATION OF EXCAVATED AREAS ADOPTED BY
THE SOUTH CAROLINA DEPARTMENT OF TRANSPORTATION**

Reclamation plans as stated herein shall include all areas disturbed in excavations of borrow and material pits, except planned inundated areas.

The final side slopes of areas excavated for borrow and material pits shall be left at such an angle so as to minimize erosion and the possibility of slides. The minimum slope in every case shall be not less than 3:1.

Small pools of water should not be allowed that are, or are likely to become noxious, odious, or foul to collect or remain on the borrow pit. Suitable drainage ditches, conduits, or surface gradient shall be constructed to avoid collection of noxious, odious, or foul pools of water unless the borrow pit is to be reclaimed into a lake or pond.

Borrow pits reclaimed to a lake or pond must have an adequate supply of water to maintain a water sufficient level to maintain a minimum water depth of four (4) feet on at least fifty (50) percent of the surface area of the lake or pond.

Excavated areas will be drained where feasible unless otherwise requested by the property owner where, in such instances, the property owner may wish to develop the excavated area for recreational purposes or for the raising of fish, or for other uses, in compliance with the South Carolina Mining Act.

Where material is stripped from the ground surface in relatively thin layers, the area, after excavation has been completed, will be thoroughly scarified and terraced and planted to establish satisfactory vegetation necessary to control erosion. Vegetative cover should be established on a continuing basis to ensure soil stability appropriate to the area. Conservation practices essential for controlling both on-site and off-site erosion and siltation must be established. A minimum of seventy-five (75) percent vegetative ground cover, with no substantial bare spots, must be established and maintained into the second growing season.

Excavated areas that are drained will be seeded to obtain a satisfactory vegetative cover. The side slopes of excavated area will be planted to vegetation.

The State Highway Engineer, or his duly appointed representative, will make a final inspection of the reclaimed area and keep a permanent record of his approval thereof. A map or sketch providing the location and approximate acreage of each pit used on the project will be made available to the Final Plans Engineer.

All applicable regulations of agencies and statutes relating to the prevention and abatement of pollution shall be complied with by the contractor in the performance of the contract.

The Contractor shall comply with the provisions of the Plan which are applicable to the project as determined by the Engineer. Seeding or other work necessary to comply with the plan on pits furnished by the contractor shall be at the expense of the contractor. Bermuda shall not be planted on ground surface pit areas. The quantity of fescue seed specified in Subsection 810.04 of the Standard Specifications shall be increased by fifteen (15) pounds in lieu of the deleted bermuda seed.

April 1, 2008

AS-BUILT CONSTRUCTION PLANS

GENERAL

The Contractor shall produce and deliver to the Department the final As-Built plans for this contract. This set of As-Built plans is not intended to document final quantities, but is intended to show approved revisions to the contract design including but not limited to: revised roadway profiles and cross sections, revised typical sections, revised drainage installations, and any changes to the demolition and removal items and any other changes to the original design.

If any design changes occur during construction, the plan sheets (or any other "job site record document" with a seal) revised after award of contract shall include a complete accounting and detail of the revisions and design changes. The P.E. responsible for the revisions shall seal each altered plan sheet (or any other "job site record document" with a seal). This documented information is to be part of the As-Built Plan requirements.

The As-Built plans shall be neat, legible and of the correct size. Bridge projects and any road projects which include Plan, Profile and Cross-Section Sheets shall be full size. In general, if the job was let with full size plans (22" x 36"), the As-Built shall be full size. All revisions to the original plans shall be delineated in red ink, located properly on the drawing, they shall be legible and true to scale. Every As-Built Plan, Profile and Cross-Section Sheet shall be designated as such by note or stamp "As-Built" in red. The As-Built Plans shall be bound in the same manner as they were let, not combined. In other words, if a project includes road and bridge work and each is bound separately, keep them separate for As-Built, each with its own AB201 cover sheet.

In submitting As-Built Plans, the Contractor shall be required to complete FORM AB205 or AB206 whichever is applicable and submit the form with the required deliverables to the RCE. The items and notes on these forms that apply to this project establish the minimum requirements for As-Built Plans. These forms can be found on the SCDOT website at <http://www.scdot.org/doing/default.html>.

The final As-Built plans shall be submitted within forth-five (45) days following the substantial work complete date of the project.

MEASUREMENT

Measurement is to be on a lump sum basis.

PAYMENT:

Payment for this item is to be as follows:

50% of the contract amount is to be distributed over the duration of the project, and paid in amount proportional to the amount of contract work completed.

The remaining 50% of the contract amount is to be paid on the final estimate of the base bid if As-Built plans meet the requirements to satisfaction of the Resident Engineer.

In no case is payment to be in excess of the original bid amount for this item.

The Bid Item for this work is as follows:

This work shall be included in the Base Bid. No additional payment will be made.

GEOTEXTILE FOR DRAINAGE FILTRATION

I. ACCEPTANCE: The Contractor shall supply to the Resident Engineer, prior to placing the material, certified test results from a recognized laboratory of those tests specified herein. Acceptance will be based on the test results meeting these requirements¹ and the material meeting all stated specifications. The Resident Engineer shall submit the certified test results to the Research and Material Engineer for acceptance.

Test data shall be no more than 1 year old at the time it is furnished to the Department. Once a fabric has been accepted, it will be listed on an Approval Sheet, and only those materials listed will be acceptable. Test data must be resubmitted for reapproval every 2 years. No fabric will be used nor will payment be made for fabric until the fabric certification is received and approved by the Research and Materials Engineer. The Department reserves the right to sample and test any of the fabrics, or other materials used in drainage filtration, at any time.

II. PIPING RESISTANCE: (soil retention- all applications)

A. Soils with 50% or less particles by weight passing U.S. No. 200 sieve:

EOS No. (fabric) C 30 U.S. Std. Sieve No.

B. Soils with more than 50% particles by weight passing U.S. No. 200 sieve:

EOS No. (fabric) C 50 U.S. Std. Sieve No.

Note:

- a. Whenever possible, fabric with the lowest possible EOS No. should be specified.
- b. When the protected soil contains particles from 1 inch size to those passing the U.S. No. 200 sieve, use only the gradation of soil passing the U.S. No.4 sieve in selecting the fabric.

III. PERMEABILITY:

Critical/Severe Applications *

Normal Applications

$$k (\text{fabric}) C 10 k (\text{soil})^2$$

$$k (\text{Fabric}) C k (\text{soil})$$

* Woven monofilament fabrics only; percent open area; 4.0 and EOS No.; 100 sieve.

IV. CHEMICAL COMPOSITION REQUIREMENTS/CONSIDERATIONS:

- A. Fibers used in the manufacture of civil engineering fabrics shall consist of long chain synthetic polymers, composed of at least 85% by weight of polyolefins, polyesters, or polyamides. These fabrics shall resist deterioration from ultraviolet exposure.
- B. The engineering fabric shall be exposed to ultraviolet radiation (sunlight) for no more than 30 days total in the period of time following manufacture until the fabric is covered with soil, rock, concrete, etc.

	Class 1 Fabric Protected	Class 2 Fabric(;) Unprotected
Grab Strength (ASTM D-4632 or ASTM D-1682)	80 lbs.	180 lbs.
Seam Strength [†] (ASTM D-4632 or ASTM D-1682)	70 lbs.	160 lbs.
Puncture Strength (ASTM D-3787)	251bs.	80 lbs.
Burst Strength (ASTM D-3786)	130 psi.	290 psi.
Trapezoid Tear (ASTM D-4533)	251bs.	50 lbs.
Ultraviolet Degradation at 150 hours (ASTM D-4355)	70%	70%

All numerical values represent minimum average roll values (i.e., any roll in a lot should meet or exceed the minimum values in the table). Use values for the weaker principal direction. Lots should be sampled according to ASTM D-4354.

- 2 Permeability should be based on the actual fabric open area available for flow. For example, if 50% of the fabric area is to be covered by flat concrete blocks, the effective flow area is reduced by 50%.
- 3 Fabric is said to be protected when used in drainage trenches or beneath/behind concrete (Portland or asphalt cement) slabs. All other conditions are said to be unprotected,

Examples of each condition are:

Protected: highway edge drains, blanket drains, smooth stable trenches < 10 feet in depth. In trenches, in which the aggregate is extra sharp, additional puncture resistance may be necessary.

Unprotected: stabilization trenches, interceptor drains on cut slopes, rocky or caving trenches or smooth stable trenches > 10 feet in depth.

- 4 Values apply to both field and manufactured seams.

[The remainder of this page intentionally left blank.]

UTILITY ALLOWANCES

1. GENERAL

1.1. RELATED DOCUMENTS

1.1.1. GENERAL: Requirements of the General and Supplemental Conditions apply to all Work in this Section. Provide all labor, material, equipment, and services indicated on the Drawings or specified herein or reasonably necessary for and incidental to a complete job.

2. PRODUCTS

2.1. STATED ALLOWANCES

2.1.1. GENERAL: The Contractor shall include in the Contract Sum the allowances stated herein. This allowance shall cover the net cost of the work performed by the utility company on the utility relocation required for the construction of the roadway and associated drainage and landscaping features. The stated allowance is intended for the adjustment or relocation of electrical and communication features within the area to be milled and paved. The Contractor's coordination, layout, field investigations, overhead, profit, and other expenses associated with utility relocations for the original allowance shall be included in the Contract Sum and not in the allowance. If the cost, when determined, is more or less than the allowance, the Contract Sum shall be adjusted accordingly by change order which will include overhead and profit due the Contractor from any increase over the original allowance.

2.1.2. UTILITY RELOCATION:

Plover Drive	<u>\$20,000.00</u>
--------------	--------------------

2.1.3. WORK NOT INCLUDED IN ALLOWANCE ITEM: Utilities damaged during construction shall not be included in the Allowance Item.

3. EXECUTION

3.1. GENERAL:

3.1.1. The Contractor shall notify the utility companies, coordinate schedule, and conduct the subsurface investigations required for the relocation of utilities by the respective utility company. This work shall be scheduled so as not to delay the work.

3.1.2. In the case of borderline conflicts, every effort shall be made, with the approval of the utility company and the Engineer, to adjust the work so a utility relocation can be avoided.

3.2. PAYMENT: The Contractor will direct the utility company to invoice the Contractor. The description of the work performed by the utility company shall be adequately identified on the invoice. Copies of the paid invoice shall be submitted with the Contractor's periodic payment request and compensation made from the allowance item.

(End of Utility Allowance Supplemental Specification)
(End of Volume II)

Georgetown County Water & Sewer District Details

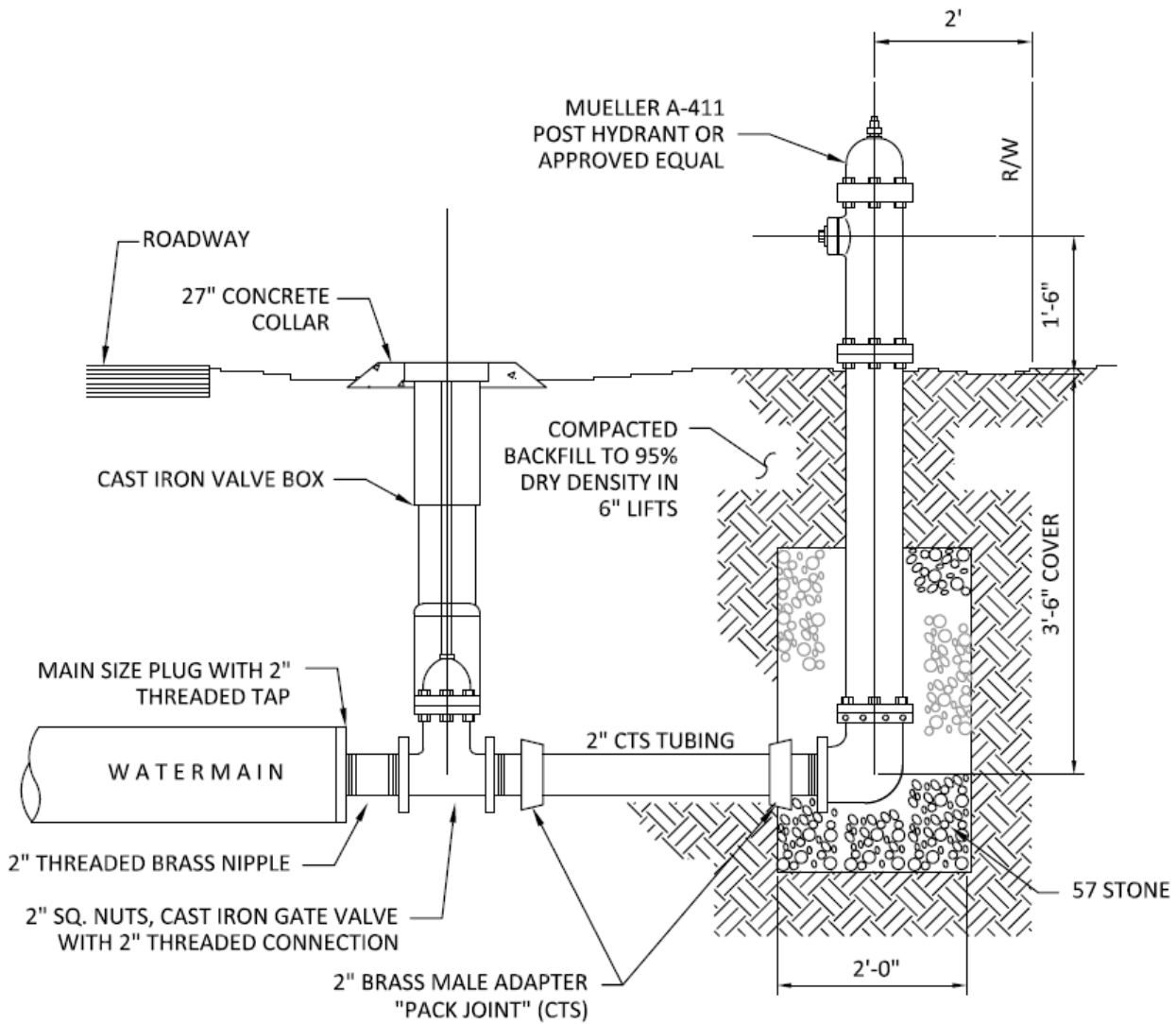

NOTES:

1. HYDRANT SHALL BE STANDARD THREADS OF LOCAL FIRE DEPARTMENT.
2. IF WATER MAIN SIZE IS 2", A BRASS MALE ADAPTER (IPS) SHOULD BE USED IN LIEU OF CAP WITH 2" TAP AND NIPPLE.
3. IF AUTOMATIC FLUSHING IS REQUIRED, THE DEVICE SHALL BE ECLIPSE 9700 OR APPROVED EQUAL.

GEORGETOWN COUNTY WATER & SEWER DISTRICT		
TYPICAL POST HYDRANT DETAIL		
UPDATED 10/02/14	SCALE N.T.S.	NO. 12 - W
DRAWN A.J.K.	CHECKED	

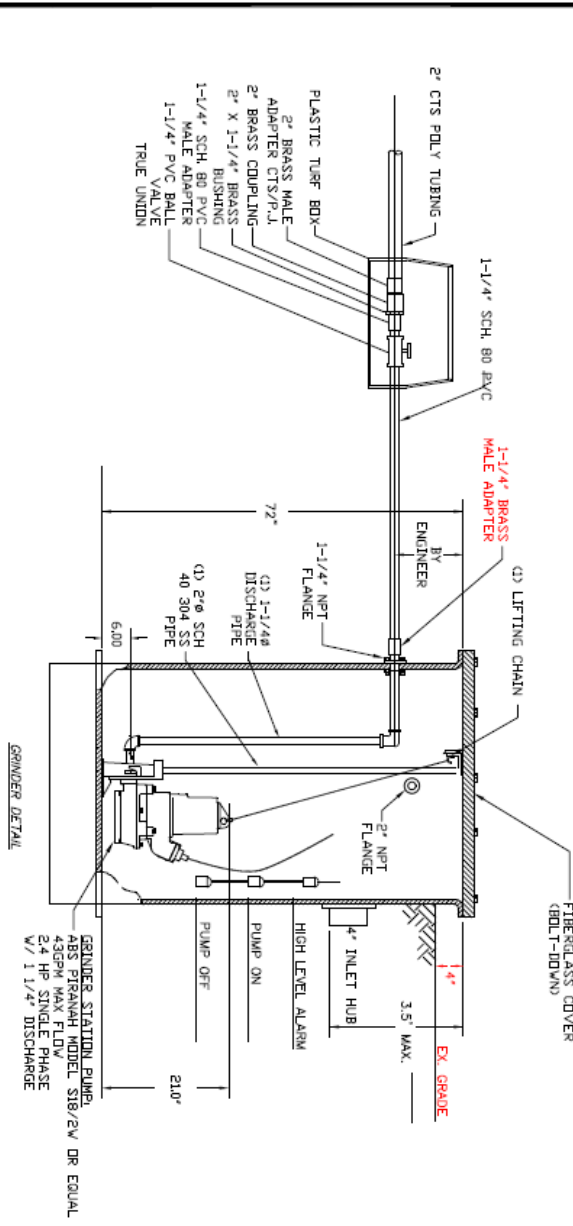
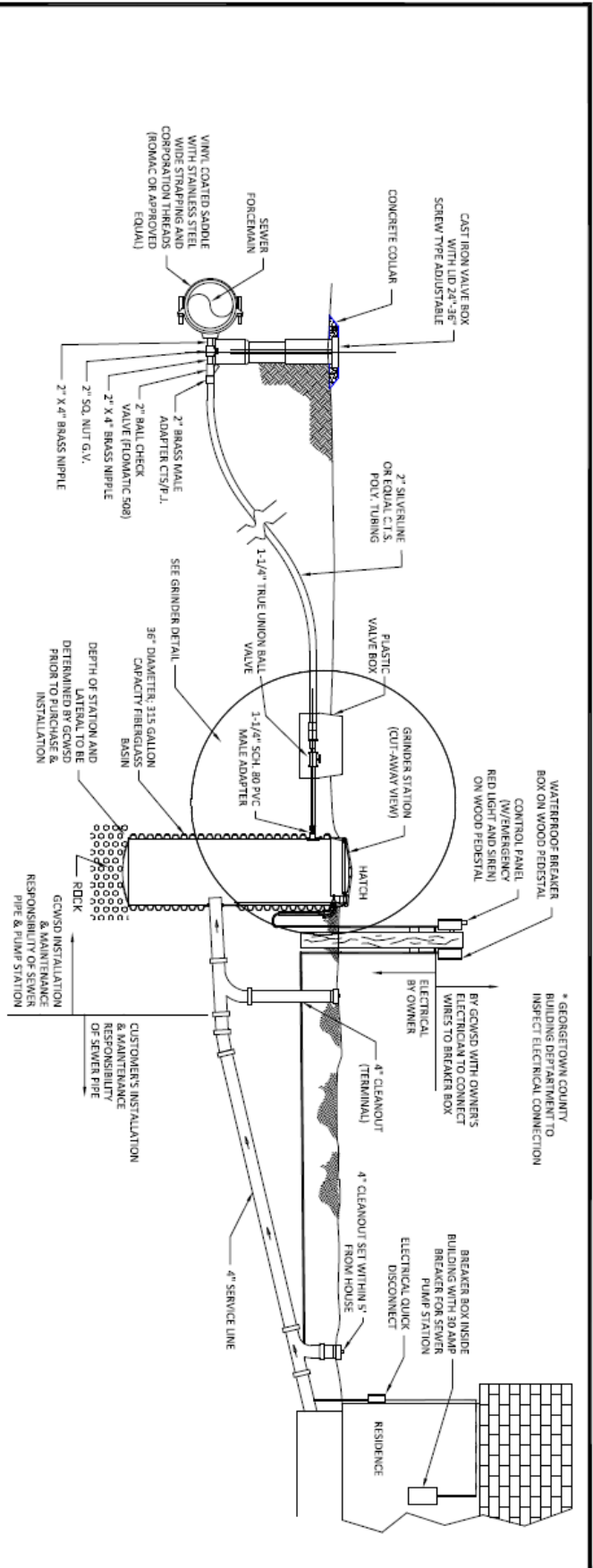

**GEORGETOWN COUNTY
WATER & SEWER DISTRICT**

**STANDARD GRINDER STATION
SERVICE LINE INSTALLATION**

DATE	SCALE	NO.
08/24/2004	NTS	
DRAWN RJV	CHECKED	

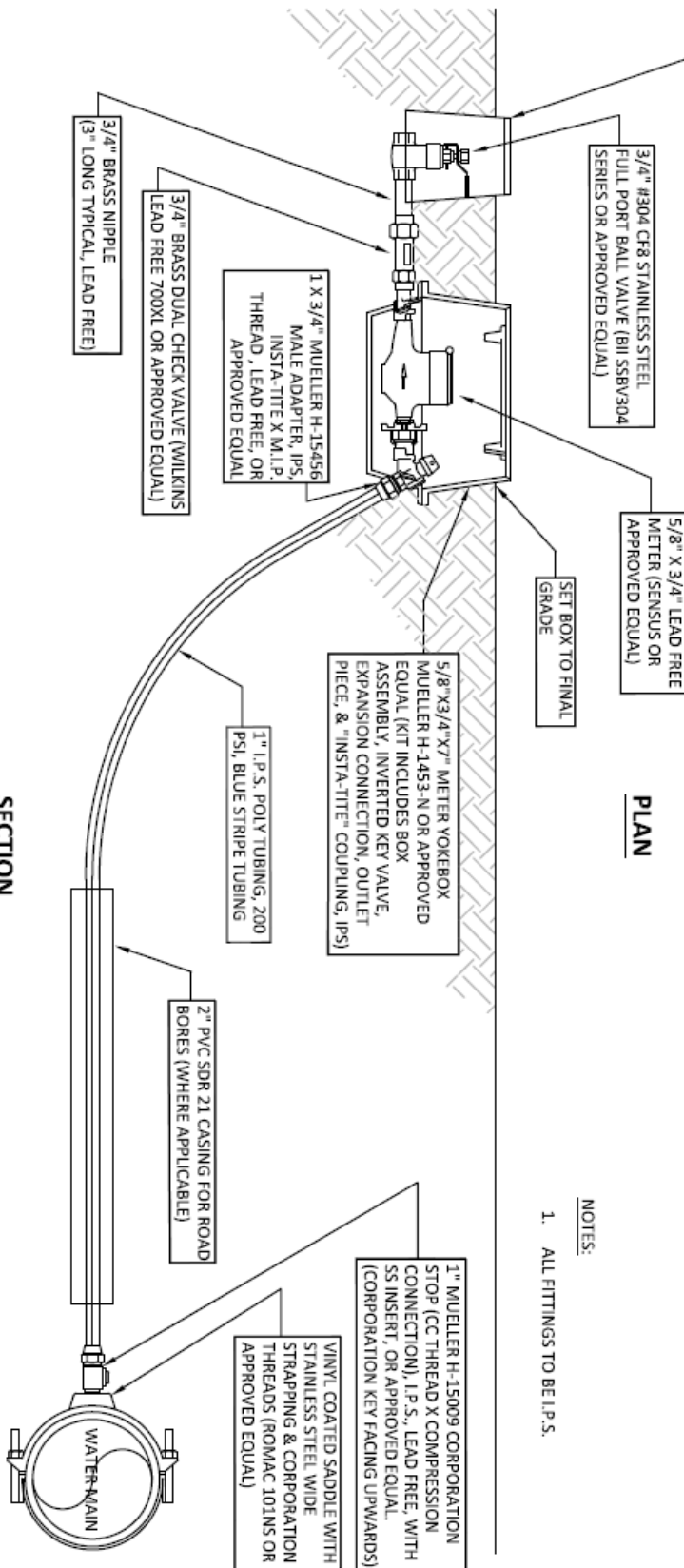
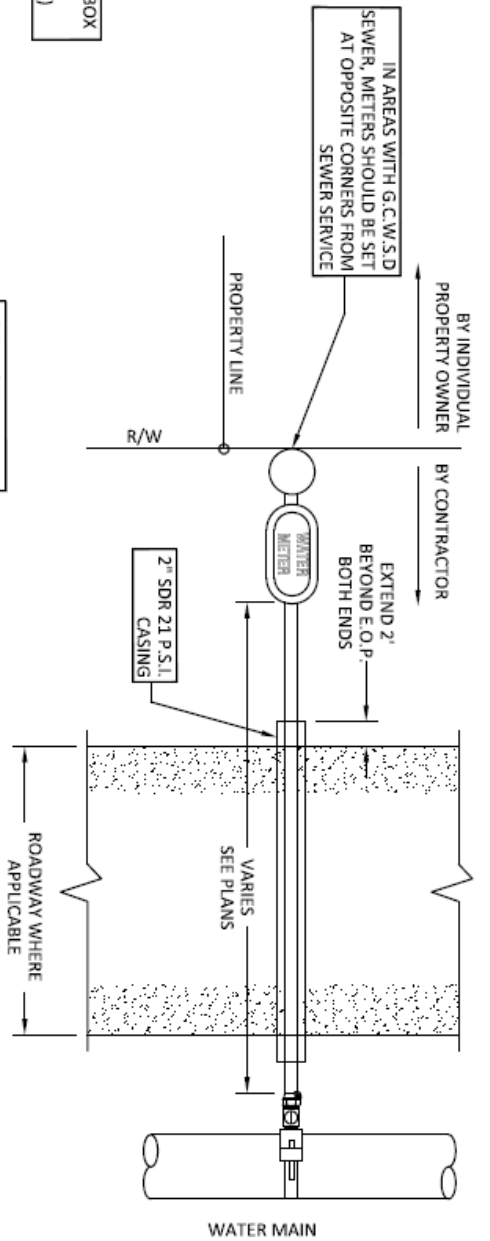

NOTES:
 1. ALL FITTINGS TO BE I.P.S.

GEORGETOWN COUNTY WATER & SEWER DISTRICT			
RESIDENTIAL WATER METER 3/4" SERVICE			
UPDATED 12/27/19	SCALE N.T.S.	NO.	
DRAWN A.J.K.	CHECKED		