



St. Johns River Water Management District

Ann B. Shortelle, Ph.D., Executive Director

4049 Reid Street • P.O. Box 1429 • Palatka, FL 32178-1429 • (386) 329-4500
On the Internet at www.sjrwmd.com.

November 30, 2020

Interested Firms

Re: Quote Request 36372, Refurbish 2 Bailey Bridges in the Upper Basin

The St. Johns River Water Management District (District) desires to Procure a contractor to refurbish two Bailey Bridges in the Upper Basin.

The objective is to refurbish each structure by replacing the existing wooden decking and wooden supports as well as painting of surface rust of the metal trusses to prevent deterioration of the trusses.

The scope of work includes removal and disposal of all deteriorated wood and hardware fasteners from each bridge, surface prep and painting of the metal trusses where surface rust exists and redecking of each bridge with wood supplied by the District. Both Bailey bridges are approximately 120 feet long by 14 feet wide. The bridges consist of a continuous 2"x 12" timber deck supported by 3"x 6" wood timbers approximately 10-inches on center. - see attached plans and photos.

If you are interested in this project, email your quote in PDF format, **after 8:00 a.m. and before 3:00 p.m. on December 30, 2020**. Do not email the quote prior to or after this timeframe. It is preferred that all quotes be submitted as an attachment to an email addressed to Amy Lucey at alucey@sjrwmd.com. Receipt will be acknowledged by 4:00 p.m. **Please contact me immediately if you do not receive an email receipt by 4:00PM.**

There will be a Non-Mandatory site visit on Tuesday December 15, 2020 at 10:00AM.

Directions to Pre-Bid Meeting:

From 195

Take Malabar Road Exit 173

Head West on Malabar Road 7.5 miles to levee entry gate on right (north side)

We will meet at gate then travel 1 mile north on levee

Please be aware of the current CDC guidelines for COVID-19, including but not limited to the following:

- Do not attend this meeting if you are feeling ill or experiencing COVID-19 symptoms
- Practice social distancing while in attendance
- Consider wearing a mask if not social distancing

Note: It is recommended that you bring your own pen for the District's sign-in sheet for attendees.

Minimum Qualifications: Respondent **must** use the Qualification Forms (Certificate as to Corporation, General, Similar Projects/References/Equipment Operator(s), Subcontractor, and Equipment Documentation) attached to document the minimum qualifications listed below. Failure to include these forms with the quote may be considered non-responsive.

1. Respondent or (a combination of the firm, individual or project manager assigned to the work) must have completed at least three projects in the last three years that shall have included projects similar to refurbishing bridges as defined in the attached Statement of Work, Exhibit 1. Each project shall have had a minimum value of \$10,000.
2. Respondent must have no less than five years of experience on projects of the nature specified above.
3. Proof of ability to do work in the State of Florida (to be provided with quote).

Once quotes are received, staff will review each quote and will make a recommendation for award based on the lowest bidder that meets all the qualifications of this quote request.

The District is a political subdivision of the state of Florida, whose boundaries cover all or portions of 18 counties, and is tax exempt (Tax ID No. 85-8012643710C-3; expires March 31, 2023). Respondent shall provide an estimate of all applicable taxes and fees in its quote, including a list of taxes and fees that fall under the District's exemption.

Opening of Quotes

1. The Florida Public Records Act, §119.071(1)(b), Fla. Stat., exempts sealed quotes from inspection and copying until such time as the District provides notice of an intended decision pursuant to §120.57(3)(a), Fla. Stat., or until 30 days after opening of quotes, whichever is earlier. This exemption is not waived by the public opening of quotes.
2. Unless otherwise exempt, Respondent's quote is a public record that is subject to disclosure upon expiration of the above exemption. If any information submitted with the Quote is a trade secret as defined in §812.081, Fla. Stat., and exempt from disclosure pursuant to §815.04, Fla. Stat., Respondent must clearly identify any such material as "CONFIDENTIAL TRADE SECRET" in its submittal and explain the basis for such exemption. The District reserves the right, in its sole judgment and discretion, to reject a submittal for excessive or unwarranted assertion of trade secret confidentiality and return the submittal to Respondent.
3. Respondents shall bear all costs associated with preparing and submitting responses to this Quote Request. The District will, in no way, be responsible for these costs, regardless of the conduct or outcome.

Inquiries and Addenda

1. District staff are not authorized to orally interpret the meaning of the Quote Request package, or correct any apparent ambiguity, inconsistency, or error therein. In order to be binding upon the District, the interpretation or correction must be given by the Procurement Specialist and must be in writing. The Procurement Specialist may orally explain the District's procedures and assist Respondents in referring to any applicable provision in the Quote Request documents, but the Respondent is ultimately responsible for submitting the quote in the appropriate form and in accordance with written procedures.
2. Every request for a written interpretation or correction must be received at least nine days prior to opening of quotes in order to be considered. Requests must be submitted by email to ALucey@sjrwmd.com. Interpretations, corrections, and supplemental instructions will be communicated by written addenda to this solicitation posted by Onvia DemandStar to all prospective Respondents (at the respective addresses furnished for such purposes) not later than five days prior to the date fixed for the Quote Request opening.
3. Submission of a quote constitutes acknowledgment of receipt of all addenda. Quotes will be construed as though all addenda had been received. Failure of the Respondent to receive any addenda does not relieve Respondent from any and all obligations under the quote, as submitted. All addenda become part of the Agreement.

Award Procedures

1. Section 286.0113, Fla. Stat., exempts from being open to the public, any portion of a meeting at which: (1) a negotiation with a Respondent is conducted pursuant to a competitive solicitation; (2) a Respondent makes an oral presentation as part of a competitive solicitation; (3) a Respondent answers questions as part of a competitive solicitation; or (4) negotiation strategies are discussed. Also, recordings of, and any records presented at, the exempt meeting are exempt from §119.07(1) and §24(a), Art. I of the State Constitution (Public Records) until such time as the District provides notice of an intended decision or until 30 days after opening the Quotes or final replies, whichever occurs earlier. A complete recording shall be made of any portion of an exempt meeting. No portion of the exempt meeting may be held off the record.
2. Pursuant to §286.0113 Fla. Stat., if the District rejects all quotes and concurrently provides notice of its intent to reissue the competitive solicitation, the recording and any records presented at any exempt meeting shall remain exempt from §119.07(1) and §24(a), Art. I of the State Constitution (Public Records) until such time as the District provides notice of an intended decision concerning the reissued competitive solicitation or until the District withdraws the reissued competitive solicitation. A recording and any records presented at an exempt meeting are not exempt for longer than 12 months after the initial District notice rejecting all quotes.
3. The District will examine the quotes to determine completeness. Obvious mismatches with regard to technical or commercial requirements will be rejected at this time.
4. If two or more quotes are equal in all respects, the Agreement will be awarded as follows: (1) to the Respondent that certifies compliance with §287.087, Fla. Stat., via the Drug-Free Workplace Form; or (2) by lot.
5. In the event the Successful Respondent(s) fail to enter into the Agreement or the Agreement with said Respondent is terminated within 90 days of the effective date, the District reserves the right to negotiate with the other respondents in ranked order, if available, and award an Agreement.
6. All Respondents will be notified of the District's intent to award or decision to award the Agreement. For the purpose of filing a protest under §120.57(3), Fla. Stat., the time period will commence as provided in "Notices and Services Thereof."

Disqualification of Respondents

Any of the following causes will be considered as sufficient grounds for disqualification of a Respondent and rejection of the Quote:

1. Contacting a District employee or officer other than Alan Weaver, the procurement specialist assigned to this solicitation action, about any aspect of this Quote Request before the notice of intended decision is posted.
2. Submission of more than one quote response for the same subject matter by an individual, firm, partnership, or corporation under the same or different names;
3. Evidence of collusion among Respondents;
4. Submission of materially false information with the Quote;
5. Information gained through checking of references or other sources which indicates that Respondent may not successfully perform the Work;
6. Respondent is failing to adequately perform on any existing contract with the District;
7. Respondent has defaulted on a previous contract with the District;
8. The evidence submitted by Respondent, or the District's investigation of Respondent, fails to satisfy the District that Respondent is properly qualified to carry out the obligations of the Agreement in a manner acceptable to the District and within the time period specified;
9. Any other cause that is sufficient to raise doubt regarding the ability of a Respondent to perform the Work in a manner that meets the District's objectives for the Work.

Rejection of Quote

1. Quotes must be emailed to the specified location and received during the time specified on page 1 in order to be considered timely. Untimely quotes will not be considered. Quotes will be

considered irregular and may be rejected if they show material omissions, alterations of form, additions not called for, conditions, limitations, unauthorized alternate quotes, or other material irregularities. The District may consider incomplete any quote not prepared and submitted in accordance with the provisions specified herein, and reserves the right to waive any minor deviations or irregularities in an otherwise valid Quote.

2. The District also reserves the right to reject any and all quotes when it determines, in its sole judgment and discretion that, it is not in its best interest to award the agreement.

Diversity

The District is committed to the opportunity for diversity in the award and performance of all procurement activities. The District encourages its primary respondents to make a good faith effort to ensure that women and minority-owned business enterprises (W/MBE) are given the opportunity for maximum participation as second and lower tier participants. The District will assist Respondents by sharing information on W/MBEs to encourage their participation.

In accordance with §287.133 and §287.134, Fla. Stat., a person or affiliate who has been placed on the convicted or discriminatory vendor lists following a conviction for a public entity crime or placement on the discriminatory vendor list may not submit a bid, proposal, or reply on a contract to provide any goods or services to a public entity; may not submit a bid, proposal, or reply on a contract with a public entity for the construction or repair of a public building or public work; may not submit bids, proposals, or replies on leases of real property to a public entity; may not be awarded or perform work as a contractor, supplier, subcontractor, or Contractor under a contract with any public entity; and may not transact business with any public entity in excess of the threshold amount provided in §287.017 for CATEGORY TWO (\$35,000) for a period of 36 months following the date of being placed on the convicted or discriminatory vendor lists.

Notices and Services Thereof

1. The District will publish notice of specifications and criteria, including addenda, intended agency decisions, or other matters pertinent to this solicitation on Onvia DemandStar at *DemandStar.com*. Onvia DemandStar may also be accessed through the District's website at *sjrwm.com*. In addition, the District will post notices of intended agency decisions at the District's headquarters, 4049 Reid Street, Palatka, Florida, Administration Building, Procurement Bulletin Board, on the date the publication is posted on Onvia DemandStar.
2. Notices that are posted on Onvia DemandStar are deemed received at 8:00 a.m. on the next business day following the date posted. Notices that are posted at the District's Procurement Bulletin Board are deemed received at 8:00 a.m. on the next business day following the date of posting. Notices will be posted for a minimum of 72 hours following the time at which they are deemed received. The time period for filing a Notice of Protest pursuant to §120.57(3), Fla. Stat., and Rule 28-110.003, Fla. Admin. Code, commences at the time notices are deemed received.
3. As a courtesy to Respondents, the District may send copies of the notices of intended agency decisions via email or facsimile to the address or phone number provided by Respondent. These courtesy communications neither constitute official notice nor vary the times of receipt set forth above.

Protest Procedures

1. Pursuant to §120.57(3), Fla. Stat., and Rule 28-110.003, Fla. Admin. Code, any person adversely affected by the procurement methodology described herein, or the specifications or criteria, including addenda, must file a Notice of Protest within 72 hours after receipt of the solicitation documents or addenda.
2. Pursuant to §120.57(3), Fla. Stat., and Rule 28-110.003, Fla. Admin. Code, any person adversely affected by a District decision or intended decision to award a contract, or to reject all bids, proposals, or qualifications, must file a Notice of Protest within 72 hours after receipt of the decision or intended decision. Pursuant to §120.57(3), Fla. Stat., and Rule 28-110.004, Fla. Admin. Code, the protester must also file with the District Clerk a Formal Written Protest within

ten days after the date the Notice of Protest is filed with the District. The Formal Written Protest must state with particularity the facts and law upon which the protest is based. Pursuant to §287.042(2)(c), Fla. Stat., any person who files an action protesting the decision or intended decision must post with the District Clerk at the time of filing the formal written protest a bond, cashier's check, or money order made payable to the St. Johns River Water Management District in an amount equal to one percent (1%) of the estimated contract amount.

3. No additional time will be added for mailing. All filings must comply with Rule 28-106.104, Fla. Admin. Code, and must be addressed to and received by the District Clerk at the District Headquarters in Palatka, Florida within the prescribed time periods. The District will not accept as filed any electronically transmitted facsimile pleadings, petitions, Notice of Protest or other documents. Failure to file a protest within the time prescribed in §120.57(3), Fla. Stat., or failure to post the bond or other security required by law within the time allowed for filing a bond will constitute a waiver of proceedings under chapter 120, Fla. Stat. Mediation under §120.573, Fla. Stat., is not available.

Thank you for your consideration of this request.

Exhibit 1 - Statement of Work/Specifications

Exhibit 2 - Quote Cost Schedule

Exhibit 3 - Qualification Forms

Exhibit 4 – Insurance Requirements

Exhibit 5 - Sample Agreement

**EXHIBIT 1 — STATEMENT OF WORK
REFURBISH (2) BAILEY BRIDGES**

I. INTRODUCTION/BACKGROUND:

The District maintains many bridges throughout the various properties. These bridges are constructed of different materials including wooden bridges, metal bridges and concrete bridges. One type of bridge is referred to as a Bailey bridge. A Bailey bridge is a pre-fabricated, truss bridge consisting of steel trusses and a wooden deck. Because of the simplicity to fabricate and the relative availability, the District purchased and installed several of these bridges to facilitate crossing of various canals. Two of these structures are located in the Upper St. Johns River Basin in Brevard County. One bridge is located just north of the west end of Malabar Road in Palm Bay and the second bridge is located approximately 4.5 miles east of SR507 (at the C54 canal) in Fellsmere (see attached location map).

II. OBJECTIVE:

The objective is to refurbish each structure by replacing the existing wooden decking and wooden supports as well as painting of surface rust of the metal trusses to prevent deterioration of the trusses.

III. SCOPE OF SERVICES:

The scope of work includes removal and disposal of all deteriorated wood and hardware fasteners from each bridge, surface prep and painting of the metal trusses where surface rust exists and redecking of each bridge with wood supplied by the District. Both Bailey bridges are approximately 120 feet long by 14 feet wide. The bridges consist of a continuous 2”x 12” timber deck supported by 3”x 6” wood timbers approximately 10-inches on center. - see attached plans and photos.

IV. TASK IDENTIFICATION:

Contractor’s Responsibility

- Conduct a preconstruction meeting with the District’s Project Manager a minimum of twenty-four (24) hour notice prior to start of work. At this meeting, the contractor should be prepared to discuss their intended process and overall schedule for completing the work. The District is requesting that work on the bridge near S-157 be completed first.
- Coordinate all work with the District’s Project Manager to ensure that a District representative is present during the performance of work.
- Mobilize to site and provide all labor, materials (except timber) and equipment necessary to perform the work in general accordance with this Statement of Work. This Statement of Work may not represent the full extent or scope of the work but provides adequate details to refurbish the bridges.
- Place necessary signage to indicate the bridge is not in service prior to removing any deck boards. The District will provide concrete barriers as requested to facilitate closing the bridge to any traffic (vehicle or pedestrian). The barriers will be placed as directed by the contractor.
- Measure and verify all lengths of existing deck and support timbers and confirm wood purchased by District is appropriate. Contractor shall be responsible for field verifying all materials. It may be necessary to field cut the 2” x 12” deck timbers to fit the dimensions of each bridge.
- Remove and dispose of all existing wooden decking, supports and hardware. The sequence and method of removing the existing wood is up to the contractor. An existing steel curbing will need to be removed along both sides of the bridge prior to removing the

timber decking. In addition, at each end of the bridge a small piece of angle iron will also need to be removed.

- Prior to redecking the bridge, pressure wash the entire metal structure. Again, sequencing of this work is up to the contractor.
- Once the surface has been pressure washed, prep all surfaces (SP3) where surface rust exists as directed by the Project Manager. Surface prep shall be in accordance with the attached specification. Much of the area to be prepped and painted is small in size (see pictures) but occur throughout the truss system. Contractor shall take every precaution to capture all scaling removed from the trusses.
- Paint all areas that have been prepped in accordance with the attached specification (System S-2).
- Install new 3"x 6" timber supports at approximately 10-inches on center, it should be noted that the timber supports are not anchored but held in place by steel curbing.
- Install new 2" x 12" deck timbers maintaining 1/4" between the deck timbers. Stagger joints per current configuration. Connect new deck timbers to new support timbers using (2) 3" x 3/8" galvanized lag bolts with washer at each end and at 4-foot intervals +/- in between. Anchors shall be countersunk into lumber 1/2" inch in depth and void filled with wood grade neoprene/silicone sealant.
- Replace steel curbing and angle iron upon once deck is complete. Replace hardware as necessary.
- Demobilize from site. The Contractor shall take care to protect all existing structures, roads, utilities and other improvements from damage. Additionally, the Work will be considered complete only after all rubbish and unused material connected with the Work has been removed and the premises left in a condition satisfactory to the District. All property disturbed or damaged during prosecution of the Work shall be restored to its former condition or better at no additional expense to the District.

District's Responsibility

- Provide site access to Contractor.
- Provide all timber support and timber decking, contractor to confirm materials received.
- Provide concrete barriers as directed by the contractor to limit access onto bridge.
- Provide direction on all areas to receive surface prep and paint.
- Provide on-site supervision of construction.
- Conduct final walk-through with Contractor.

V. TIME FRAMES AND DELIVERABLES

The work is authorized to proceed on the date fully executed Contract is issued by the District. The Work shall be completed no later than April 30, 2021. The District shall inspect the Contractor's work within 24 hours. Contractor shall correct any deficiencies noted from the inspection.

VI. BUDGET/COST SCHEDULE

PAYMENT OF INVOICES

Contractor shall submit monthly itemized invoices based on a percentage of completion by one of the following two methods: (1) by mail to the St. Johns River Water Management District, Director, Division of Financial Management, 4049 Reid Street, Palatka, Florida 32177, or (2) by e-mail to acctpay@sjrwmd.com. Each invoice shall be submitted in detail sufficient for proper pre-audit and post-audit review. If necessary for audit purposes, the District may require and Contractor shall provide additional supporting information to document invoices.

PROJECT MANAGER

James Rider
Public Works Program Manager
321-863-0029 (cell)
321-984-4941 (office)
jrider@sjrwmd.com (email)

Attachments:

Map Bailey Bridges USJRB
Picture Bailey Bridge Surfaces
Picture Bailey Bridge Rust to be Prepped and Cleaned
Drawing Bailey Bridge

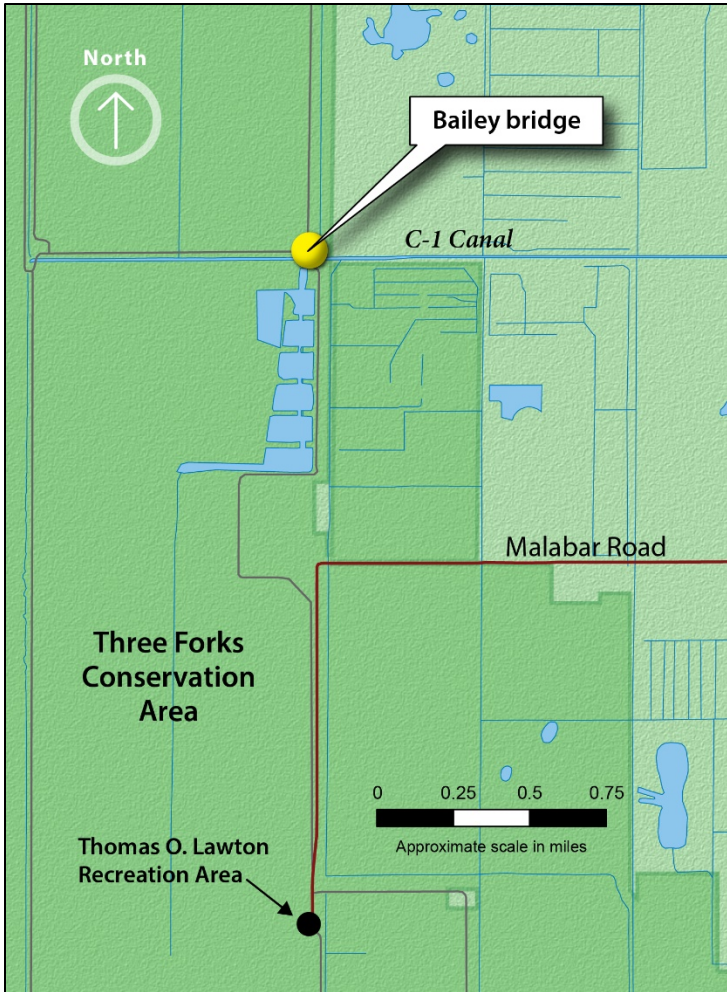

Directions: Take Malabar Road west to end. Turn north through locked gate. Bridge is approximately 1.0 miles north on L-74.

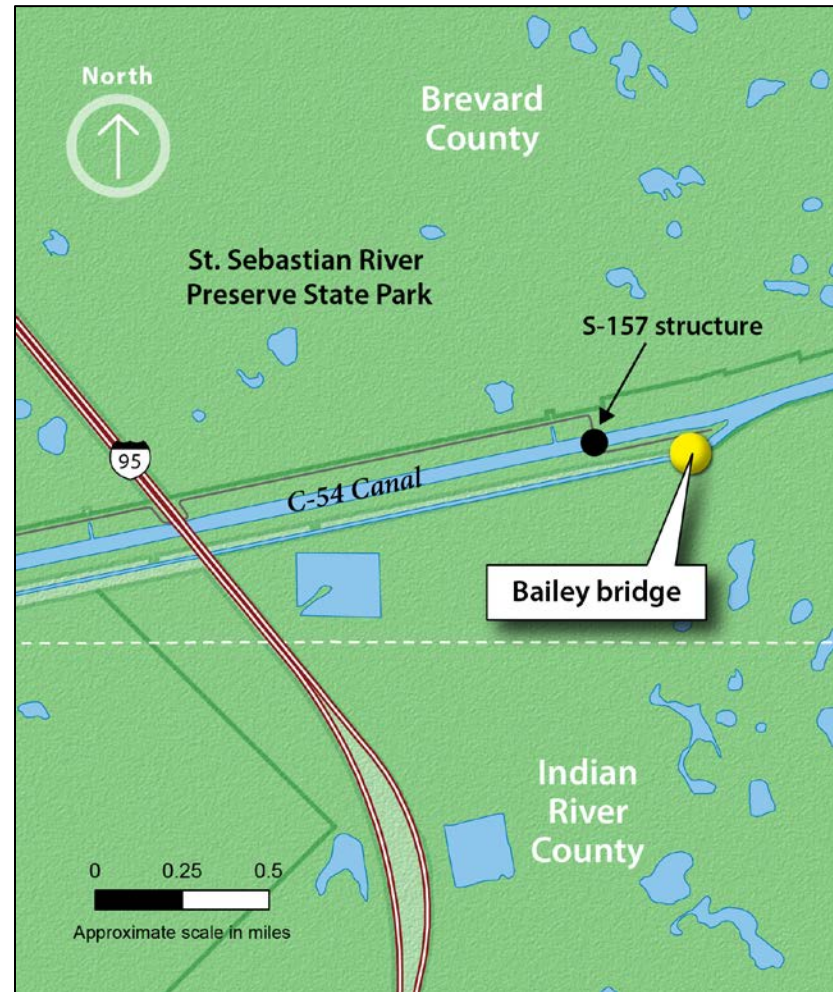

Directions: Take SR507 south to Buffer Preserve Drive (east), continue on Buffer Preserve Drive to S-157. Bridge is approximately 0.35 miles past S-157.

Figure 1 - Bailey Bridge Locations



Existing Bridge Decking (North of Malabar)



Existing Bridge Decking (South of S-157)



Typical Areas of Rust to be Prepped and Cleaned

TYPICAL EXTENT OF CHORD REINFORCEMENT = TOTAL NUMBER OF BAYS MINUS 2

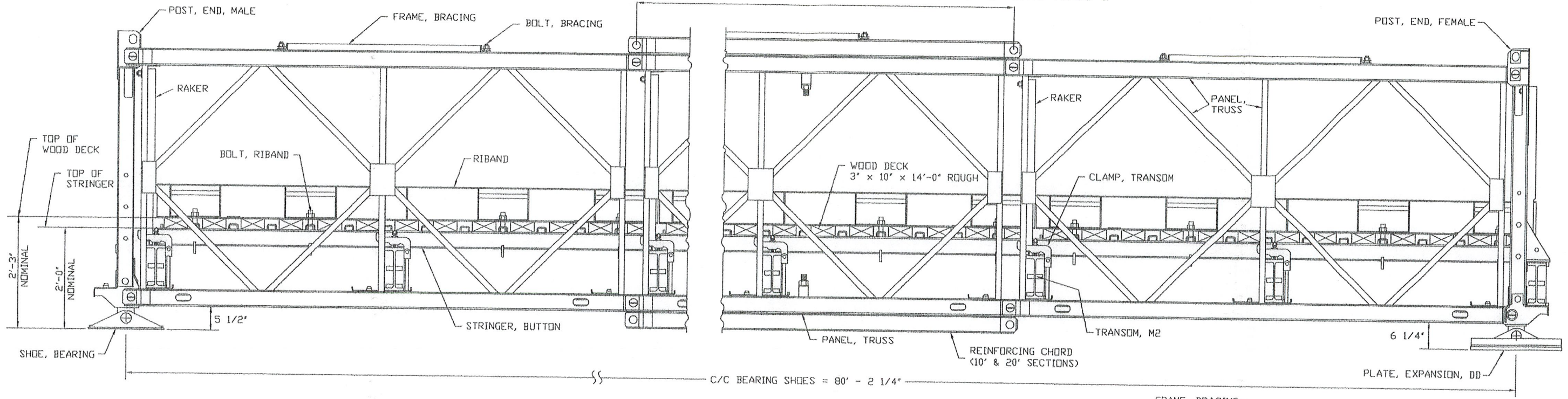

SIDE ELEVATION

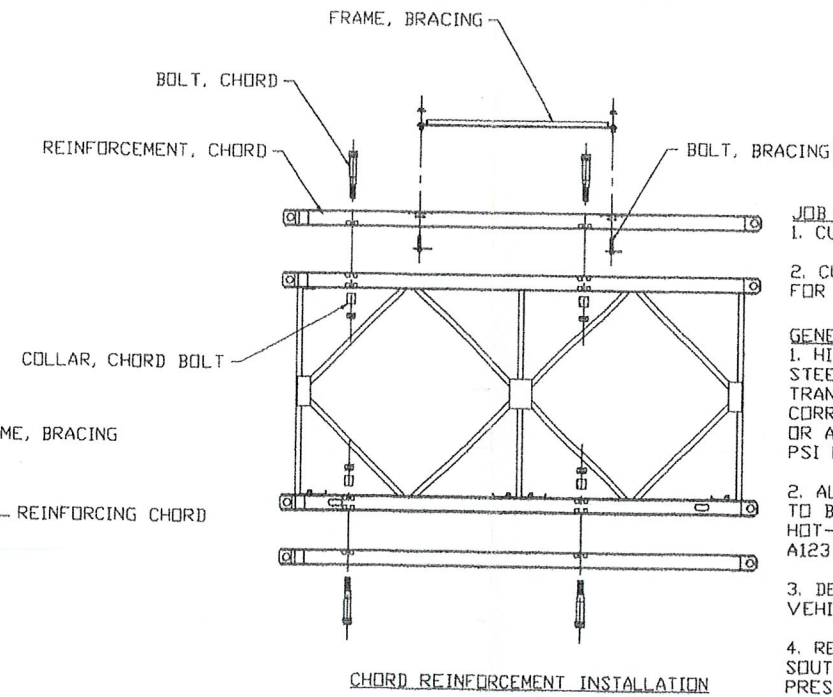

- JOB NOTES:**
1. CUSTOMER TO INSTALL BRIDGE.
 2. CUSTOMER TO PROVIDE WOOD FOR BRIDGE DECK.
- GENERAL NOTES:**
1. HIGH-STRENGTH, LOW-ALLOY STEEL IN PANELS, STRINGERS, TRANSOMS AND END POSTS CORRESPONDS TO ASTM SPEC A242 OR A572 GRADE 50 WITH 50,000 PSI MINIMUM YIELD POINT.
 2. ALL PRIMARY STEEL COMPONENTS TO BE INORGANIC ZINC COATED OR HOT-DIPPED GALVANIZED TO ASTM A123 SPECS.
 3. DESIGN LOAD: HS15 (54,000# VEHICLE LOAD)
 4. RECOMMENDED WOOD IS SOUTHERN YELLOW PINE #1 PRESSURE TREATED TO 0.4 RETENTION.
 5. ALL HARDWARE TO BE PAINTED BLACK OR ZINC COATED.

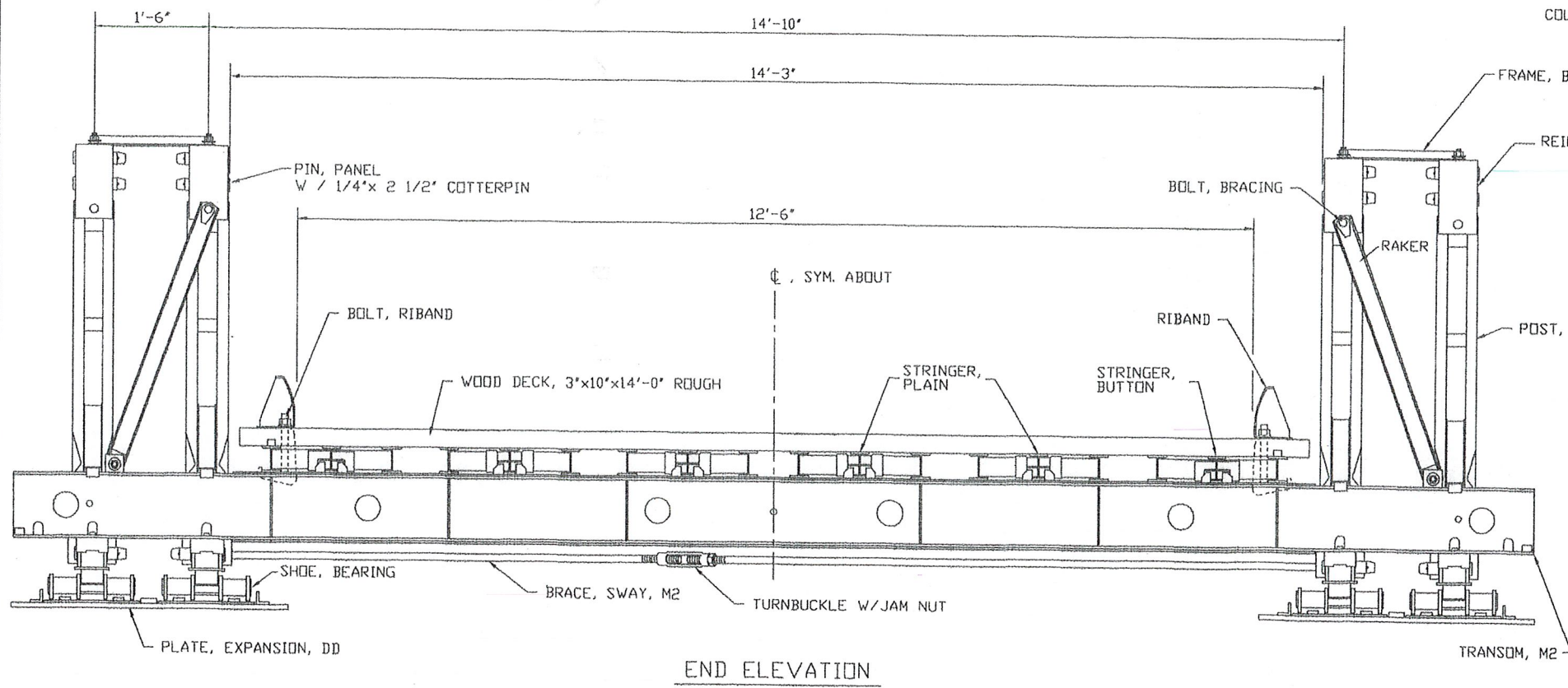

END ELEVATION

REVISIONS	DATE

BAILEY BRIDGES, INC.

119 40th St., N.E., Ft. Payne, AL 35967
 PH: 205-845-7575 FAX: 205-845-1775 www.baileybridge.com

CUSTOMER: ST. JOHN'S RIVER WATER MGMT DISTRICT
 FOR: ST JOHN'S RIVER
 ENG.: X
 PROJ.: X
 LOCATION: X
 TITLE: 80-FT DSRM2-W BAILEY BRIDGE
 CUST./P.O. NO. 08091B DWG. NO. 1004L REV. 2

APPROVAL STAMP

DRAWN: AF 04/04/08
 CHECKED: GIL 04/14/08

DRAWING NOT TO SCALE UNLESS NOTED
 DRAWING AND CONTENTS PROPERTY OF BAILEY BRIDGES, INC.

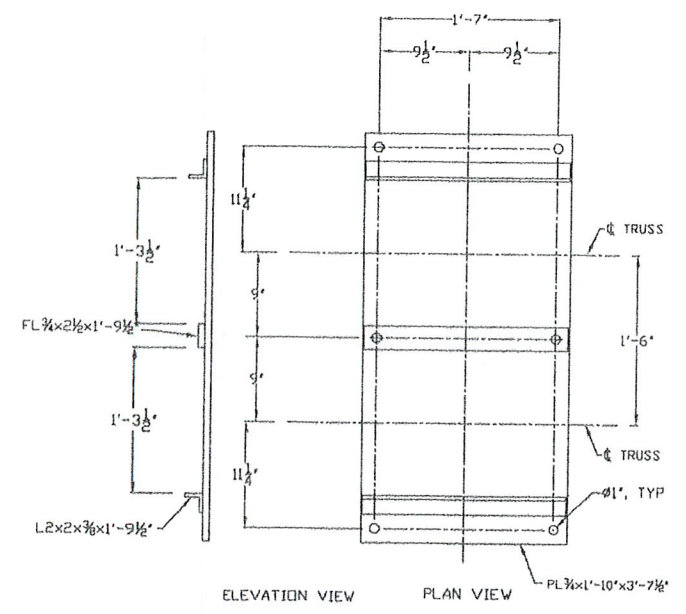
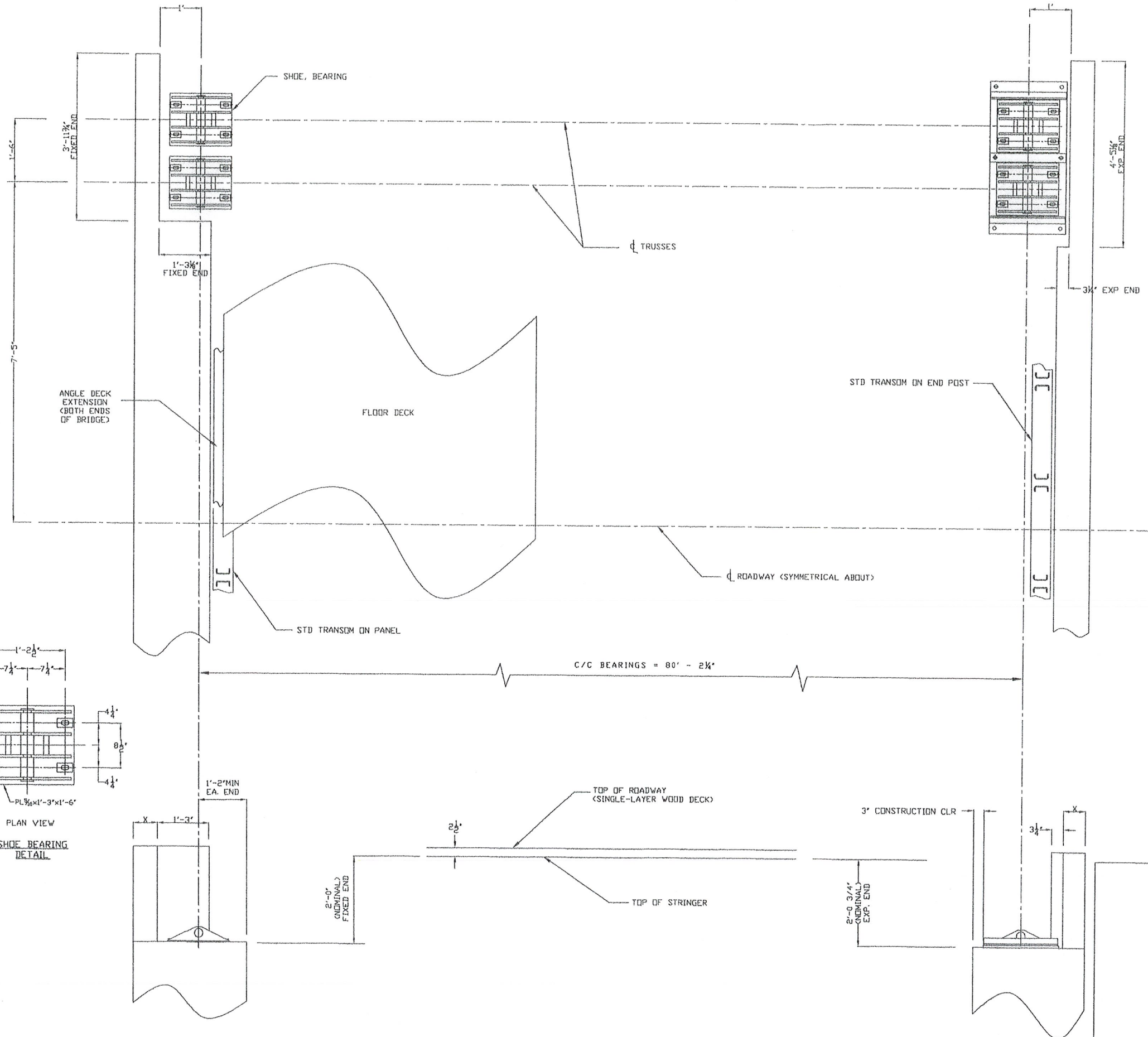

BRIDGE ABUTMENT DESIGN REACTIONS

REACTIONS PER ABUTMENT
AASHTO HS20 LIVE LOAD

LIVE LOAD REACTION = 63.6 KIPS
(EXCLUDES IMPACT)
DEAD LOAD REACTION = 39.0 KIPS
HOR. WIND LOAD REACTION = 18.0 KIPS

TOTAL VERTICAL REACTION = 81.6 KIPS

GENERAL NOTES:
1. ACTUAL DESIGN OF ABUTMENTS TO BE BY OTHERS TO SUIT SITE CONDITIONS.
2. "X" DIMENSION TO BE DETERMINED BY ABUTMENT DESIGNER.

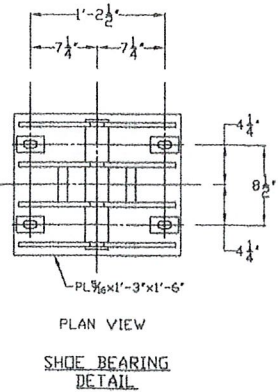

BRIDGE END DRAWING
PLAN AND ELEVATION VIEWS

APPROVAL STAMP

DRAWN: JH 03/28/07
CHECKED: GIL 04/14/08

REVISIONS	DATE

BAILEY BRIDGES, INC.
119 40th St., N.E., Ft. Payne, AL 35967
PH: 256-845-7875
FAX: 256-845-7775
www.baileybridge.com

CUSTOMER: ST JOHN'S RIVER WATER MGMT DISTRICT
FOR: ST JOHN'S RIVER
ENG.: X
PROJ.: X
LOCATION: BREVARD COUNTY, FL
TITLE: 80-FT DSR-M2 STD END
CUST./P.O. NO. BAILEY JOB NO. DWG. NO. TOTAL REV.
08091B 2 2

EXHIBIT 2 - QUOTE COST SCHEDULE
(Note: This page must be submitted with response.)

DUE NO LATER THAN 3:00 PM, THURSDAY December 30, 2020- RESPONSES SHALL BE SUBMITTED TO THE PROCUREMENT SPECIALIST AS IDENTIFIED ON THE FIRST PAGE OF THIS REQUEST.

COST SCHEDULE - BAILEY BRIDGES					
ITEM NO	DESCRIPTION	ESTIMATED QUANTITY	UNIT	UNIT PRICE	TOTAL PRICE
Bailey Bridge - South of S-157					
1	Mobilize	1	LS		
2	Remove and Replace Timber Deck and Supports (Inclusive)	1	LS		
3	Pressure Wash Structure	1	LS		
4	Prep and Paint Surface Rust	10	GAL		
5	Demobilize	1	LS		
Total Price for S-157 Bailey Bridge					
Bailey Bridge - North of Malabar Road					
1	Mobilize	1	LS		
2	Remove and Replace Timber Deck and Supports (Inclusive)	1	LS		
3	Pressure Wash Structure	1	LS		
4	Prep and Paint Surface Rust	10	GAL		
5	Demobilize	1	LS		
Total Price for Malabar Road Bailey Bridge					
TOTAL PRICE ALL WORK					
Please note that the District is compensating the Contractor per gallon of paint used,					

I HEREBY ACKNOWLEDGE, as Authorized Representative for the Respondent, that I have fully read and understand all terms and conditions as set forth in this quotation, and upon award of such quotation, shall fully comply with such terms and conditions.

Acknowledgment is hereby made of the following addenda (identified by number) received:

Addendum No.	Date	Addendum No.	Date
<u> 1 </u>	<u> </u>	<u> </u>	<u> </u>
<u> 2 </u>	<u> </u>	<u> </u>	<u> </u>
<u> 3 </u>	<u> </u>	<u> </u>	<u> </u>

RESPONDENT (FIRM NAME)

ADDRESS

SIGNATURE

TYPED NAME & TITLE

TELEPHONE NUMBER

EMAIL ADDRESS

EXHIBIT 3 – QUALIFICATION FORMS
CERTIFICATE AS TO CORPORATION

(This form to be included in quote submittal)

The below Corporation is organized under the laws of the State of _____; is authorized by law to respond to this Invitation for Bids and perform all work and furnish materials and equipment required under the Agreement, and is authorized to do business in the State of Florida.

Corporation name: _____

Address:

Registration No.:

Registered Agent:

By: _____
_____ (Official title)

(Affix corporate seal)

Attest:
_____ (Secretary)

The full names and business or residence addresses of persons or firms interested in the foregoing bid as principals or officers of Respondent are as follows (specifically include the President, Secretary, and Treasurer and state the corporate office held of all other individuals listed):

Identify any parent, subsidiary, or sister corporations involving the same or substantially the same officers and directors that will or may be involved in performance of the Project, and provide the same information requested above on a photocopy of this form.

If applicable, attach a copy of a certificate to do business in the State of Florida, or a copy of the application that has been accepted by the State of Florida to do business in the State of Florida, for the Respondent and/or all out-of-state corporations that are listed pursuant to this form.

QUALIFICATION GENERAL
(This form to be included with quote submittal)

As part of the quote request, Respondent shall complete the following so that the District can determine Respondent's ability, experience, and facilities for performing the Work.

Name of Respondent:

Respondent's tax identification No.: _____

Year company was organized/formed: _____

Number of years Respondent has been engaged in business under the present firm or trade name:

Total number of years Respondent has experience in similar work described in quote request of the Instructions to Respondents: _____

Has Respondent previously been engaged in the same or similar business under another firm or trade name? If so, please describe each such instance.

Has Respondent ever been adjudicated bankrupt, initiated bankruptcy, or been the subject of bankruptcy proceedings on behalf of the current entity submitting this bid or a prior entity that Respondent substantially operated or controlled? If yes, please describe the nature and result of those proceedings and the entity involved.

Describe the background/experience of the person or persons who will be primarily responsible for directing the Work that will be performed pursuant to this bid. This inquiry is intended to encompass the project manager and/or superintendent who will be engaged on a daily basis in directing performance of the Work.

QUALIFICATIONS – SIMILAR PROJECTS
(This form to be included in quote submittal)

Respondent and Respondent’s Proposed Operator(s) must have completed at least three projects in the last three years that shall have included projects similar to refurbishing bridges as defined the attached Statement of Work, Exhibit 2. Each project shall have had a minimum value of \$10,000. This form shall be completed for both the Respondent and the Respondent’s Proposed Operator(s) unless the Proposed Operator(s) worked on the same project being submitted for the Respondent’s qualifications.

Completed Project #1:

Agency/company: _____

Current contact person at agency/company: _____

Telephone: _____ Fax: _____ E-mail: _____

Address of agency/company: _____

Name of project: _____

Equipment Operator: _____

Description:

Project value: _____ Start date: _____ Completion date: _____
 (month/year) (month/year)

Name(s) of assigned personnel:

Project manager: _____

Others: _____

Completed Project #2:

Agency/company: _____

Current contact person at agency/company: _____

Telephone: _____ Fax: _____ E-mail: _____

Address of agency/company: _____

Name of project: _____

Equipment Operator: _____

Description:

Project value: _____ Start date: _____ Completion date: _____
 (month/year) (month/year)

Completed Project #3:

Agency/company: _____

Current contact person at agency/company: _____

Telephone: _____ Fax: _____ E-mail: _____

Address of agency/company: _____

Name of project: _____

Equipment Operator: _____

Description:

Project value: _____ Start date: _____ Completion date: _____
(month/year) (month/year)

EXHIBIT 4— INSURANCE

Consultant shall acquire and maintain until completion of the Work the insurance coverage listed below, which constitutes primary coverage. Consultant shall not commence the Work until the District receives and approves Certificates of Insurance documenting required coverage. Consultant's General Liability policy shall include Endorsement CG 20 10 04 13, or equivalent, naming the St. Johns River Water Management District (the "District") as Additional Insured. All required policies shall include: (1) endorsement that waives any right of subrogation (Endorsement 24 04 05 09, or equivalent) against the District for any policy of insurance provided under this requirement or under any state or federal worker's compensation or employer's liability act; (2) endorsement to give the District no less than 30 days' notice in the event of cancellation or material change. Certificates of Insurance must be accompanied by copies of the requested endorsements.

Any deductibles or self-insured retentions above \$100,000 must be declared to and approved by the District. Approval will not be unreasonably withheld. Consultant is responsible for any deductible or self-insured retention. Insurance must be placed with insurers having an A.M. Best rating of A-V or greater. District receipt of insurance certificates providing less than the required coverage does not waive these insurance requirements.

1. **Workers' Compensation Insurance.** Workers' compensation and employer's liability coverage, including maritime workers compensation, if applicable, in not less than the minimum limits required by Florida law. If Contractor claims an exemption from workers' compensation coverage, Contractor must provide a copy of the Certificate of Exemption from the Florida Division of Workers' Compensation for all officers or members of an LLC claiming exemption who will be participating in the Work. In addition, Contractor must provide a completed District "Affidavit (Non-Construction)" for non-construction contracts. Contractor is solely responsible for compliance with any Federal workers' compensation laws such as Jones Act and USL&H Act, including any benefits available to any workers performing work on this project.
2. **General Liability.** Commercial General Liability Insurance on an "Occurrence Basis," with limits of liability for each occurrence of not less than \$1,000,000 for personal injury, bodily injury, and property damage, with an aggregate of \$2,000,000. Coverage shall include: (1) contractual liability, (2) products and completed operations, (3) independent contractors, and (4) property in the care, control, or custody of Contractor. Extensions shall be added or exclusions deleted to provide the necessary coverage.
3. **Automobile Liability.** Minimum limits of \$100,000/\$300,000/\$100,000.

**EXHIBIT 5 – SAMPLE AGREEMENT
DRAFT AGREEMENT BETWEEN THE
ST. JOHNS RIVER WATER MANAGEMENT DISTRICT
AND _____ FOR
REFURBISH TWO BAILEY BRIDGES**

THIS AGREEMENT is entered into by and between the GOVERNING BOARD of the ST. JOHNS RIVER WATER MANAGEMENT DISTRICT (the “District”), whose address is 4049 Reid Street, Palatka, Florida 32177-2571, and (“Contractor”), whose address is . All references to the parties hereto include the parties, their officers, employees, agents, successors, and assigns.

In consideration of the payments hereinafter specified, Contractor agrees to furnish and deliver all materials and perform all labor required for Contract 33278, Weather Shelter – Willow (Three Forks Marsh) (the “Work”). Contractor shall complete the Work in conformity with this Agreement, which includes the Statement of Work and any Special Conditions or other attachments. If any provision in the body of this Agreement conflicts with any attachment hereto, the body of this Agreement shall prevail. The parties hereby agree to the following terms and conditions.

1. TERM

- (a) The term of this Agreement shall be from the Effective Date to the Completion Date. Time is of the essence for each and every aspect of this Agreement. Where additional time is allowed to complete the Work, the new time limit shall also be of the essence. All provisions of this Agreement that by their nature extend beyond the Completion Date survive termination or expiration hereof.
- (b) **Effective Date.** The Effective Date is the date upon which the last party to this Agreement has dated and executed the same.
- (c) **Completion Date.** The Completion Date of this Agreement is April 30, 2021, unless extended by mutual written agreement of the parties. The Work shall be completed for use no later than said date.

2. DELIVERABLES

- (a) The Work is specified in the Statement of Work, Attachment A. Contractor shall deliver all products and deliverables as stated therein. Contractor is responsible for the professional quality, technical accuracy, and timely completion of the Work. Both workmanship and materials shall be of good quality. Contractor shall, if required, furnish satisfactory evidence as to the kind and quality of materials provided. Unless otherwise specifically provided for herein, Contractor shall provide and pay for all materials, labor, and other facilities and equipment necessary for performance of the Work. The District’s Project Manager shall make a final acceptance inspection of the deliverables when completed and finished in all respects.
- (b) If not otherwise addressed in the Statement of Work, upon written request, Contractor shall submit written progress reports to the District’s Project Manager at the frequency requested in the form approved by the Project Manager at no additional cost to the District. The progress report shall provide an updated progress schedule, taking into account all delays and approved changes in the Work. Failure to provide a progress report will be cause to withhold payment.

- 3. **OWNERSHIP OF DELIVERABLES.** The Work is specified in the Statement of Work, Attachment A. Contractor shall deliver all products and deliverables as stated therein. Contractor is responsible for the professional quality, technical accuracy, and timely completion of the Work. Both workmanship and materials shall be of good quality. Contractor shall, if required, furnish satisfactory evidence as to the kind and quality of materials provided. Unless otherwise specifically provided for herein, Contractor shall provide and pay for all materials, labor, and other facilities and equipment necessary for performance of the Work. The District’s Project Manager shall make a final acceptance inspection of the deliverables when completed and finished in all respects.

4. FUNDING OF AGREEMENT

- (a) For satisfactory performance of the Work, the District agrees to pay Contractor \$_____ (the "Total Compensation").

5. PAYMENT OF INVOICES

- (a) Contractor shall submit by one of the following two methods: (1) by email to acctpay@sjrwmd.com (preferred) or (2) by mail to the St. Johns River Water Management District, Finance Director, 4049 Reid Street, Palatka, Florida 32177-2571. Each invoice shall be submitted in detail sufficient for proper pre-audit and post-audit review. If necessary for audit purposes, Contractor shall provide additional supporting information as required to document invoices.
- (b) **End of District Fiscal Year Reporting.** The District's fiscal year ends on September 30. Irrespective of the invoicing frequency, the District is required to account for all encumbered funds at that time. When authorized under the Agreement, submittal of an invoice as of September 30 satisfies this requirement. The invoice shall be submitted no later than October 30. If the Agreement does not authorize submittal of an invoice as of September 30, Contractor shall submit, prior to October 30, a description of the additional Work completed between the last invoice and September 30, and an estimate of the additional amount due as of September 30 for such Work. If there have been no prior invoices, Contractor shall submit a description of the Work completed on the project through September 30 and a statement estimating the dollar value of that Work as of September 30.
- (c) **Final Invoice.** The final invoice must be submitted no later than 45 days after the Completion Date; provided, however, that when the Completion Date corresponds with the end of the District's fiscal year (September 30), the final invoice must be submitted no later than 30 days after the Completion Date. **Final invoices that are submitted after the requisite date shall be subject to a penalty of ten percent of the invoice. This penalty may be waived by the District, in its sole judgment and discretion, upon a showing of special circumstances that prevent the timely submittal of the final invoice. Contractor must request approval for delayed submittal of the final invoice not later than ten days prior to the due date and state the basis for the delay.**
- (d) All invoices shall include the following information: (1) District contract number; (2) Contractor's name and address (include remit address, if necessary); (3) Contractor's invoice number and date of invoice; (4) District Project Manager; (5) Contractor's Project Manager; (6) supporting documentation as to cost and/or project completion (as per the cost schedule and other requirements of the Statement of Work; (7) Progress Report (if required); (8) Diversity Report (if otherwise required herein). Invoices that do not correspond with this paragraph shall be returned without action, stating the basis for rejection. Payments shall be made within 45 days of receipt of an approved invoice. Disputes regarding invoice sufficiency are resolved pursuant to the dispute resolution procedure of this Agreement.
- (e) **Travel expenses.** If the cost schedule for this Agreement includes a line item for travel expenses, travel expenses shall be drawn from the project budget and are not otherwise compensable. If travel expenses are not included in the cost schedule, they are a cost of providing the service that is borne by Contractor and are only compensable when specifically approved by the District as an authorized District traveler. In such instance, travel expenses must be submitted on District or State of Florida travel forms and shall be paid pursuant to District Administrative Directive 2000-02.
- (f) **Payments.** Absent exceptional circumstances, Contractor is required to sign up and receive payment(s) electronically from the District via Automated Clearing House (ACH) payment.

- (g) **Payments withheld.** The District may withhold or, on account of subsequently discovered evidence, nullify, in whole or in part, any payment to such an extent as may be necessary to protect the District from loss as a result of: (1) defective Work not remedied; (2) failure of Contractor to make payments when due to subcontractors or suppliers for materials or labor; (3) failure to maintain adequate progress in the Work; (4) damage to another contractor; or (5) any other material breach of this Agreement. Amounts withheld shall not be considered due and shall not be paid until the ground(s) for withholding payment have been remedied.
- (h) **Payments.** The District shall pay Contractor 100% of each approved invoice.
6. **PAYMENT AND RELEASE.** Upon satisfactory completion of the Work, the District will provide Contractor a written statement accepting all deliverables. Contractor's acceptance of final payment shall constitute a release in full of all Contractor claims against the District arising from the performance of this Agreement, with the exception of any pending claims for additional compensation that have been documented and filed as required by this Agreement.
7. **INDEMNIFICATION.** Contractor shall indemnify and hold harmless, release, and forever discharge the District, its public officers, employees, agents, representatives, successors, and assigns, from any and all liabilities, damages, losses, and costs, including, but not limited to, reasonable attorney's fees, arising from or caused by the Contractor, its employees or subcontractors, in the performance of the Work. Contractor shall further indemnify the District for all costs and penalties the District incurs related to any failure to offer Patient Protection and Affordable Care Act compliant health care coverage to Contractor-employees performing under this contract.
8. **INSURANCE.** Contractor shall acquire and maintain all insurance required by Attachment B, Insurance Requirements, and shall not commence Work until it has provided Certificates of Insurance to the District as per Attachment B. Receipt of Certificates of Insurance indicating less coverage than required does not constitute a waiver of the Insurance Requirements. Contractor waives its right of recovery against the District to the extent permitted by its insurance policies. Contractor's insurance shall be considered primary, and District insurance shall be considered excess, as may be applicable to Contractor's obligation to provide insurance.
9. **FUNDING CONTINGENCY.** This Agreement is at all times contingent upon funding availability, which may include a single source or multiple sources, including, but not limited to: (1) ad valorem tax revenues appropriated by the District's Governing Board; (2) annual appropriations by the Florida Legislature, or (3) appropriations from other agencies or funding sources. Agreements that extend for a period of more than one Fiscal Year are subject to annual appropriation of funds in the sole discretion and judgment of the District's Governing Board for each succeeding Fiscal Year. Should the Work not be funded, in whole or in part, in the current Fiscal Year or succeeding Fiscal Years, the District shall so notify Contractor and this Agreement shall be deemed terminated for convenience five days after receipt of such notice, or within such additional time as the District may allow. For the purpose of this Agreement, "Fiscal Year" is defined as the period beginning on October 1 and ending on September 30.
10. **PROJECT MANAGEMENT PERSONNEL**
- (a) The Project Managers listed below shall be responsible for overall coordination and management of the Work. Either party may change its Project Manager upon three business days' prior written notice to the other party. Written notice of change of address shall be provided within five business days. All notices shall be in writing to the Project Managers at the addresses below and shall be sent by one of the following methods: (1) hand delivery; (2) U.S. certified mail; (3) national overnight courier; (4) email or, (5) fax. Notices via certified mail are deemed delivered upon receipt. Notices via overnight courier are deemed delivered one business day after having been deposited with the courier. Notices via email or fax are deemed delivered on the date transmitted and received.

DISTRICT

James Rider, Project Manager
 St. Johns River Water Management District
 525 Community College Parkway, S.E
 Palm Bay, FL 32909-2213
 Phone: 321-863-0029
 Email: jrider@sjrwmd.com

CONTRACTOR

, Project Manager

 Phone:
 Email:

- (b) The District's Project Manager shall have sole responsibility for transmitting instructions, receiving information, and communicating District policies and decisions regarding all matters pertinent to performance of the Work.
- (c) Contractor shall provide efficient supervision of the Work, using its best skill and attention. Contractor shall keep, on the worksite during its progress, a competent superintendent that is satisfactory to the District. The superintendent shall not be changed except with the District's consent, unless the superintendent proves to be unsatisfactory to Contractor and/or ceases to be in its employ. The superintendent shall represent Contractor in the absence of Contractor's Project Manager. All directions given to him shall be as binding as if given to Contractor. If the District produces documented evidence and informs the Contractor that any person on the job is incompetent, disorderly, or is working contrary to the Agreement or the District's instructions, that person shall thereupon be immediately dismissed from the project and shall not be given employment on any work connected with this Agreement. The District may request Contractor replace its Project Manager if said manager fails to carry the Work forward in a competent manner, follow instructions or specifications, or for other reasonable cause.
- (d) Contractor shall maintain an adequate and competent professional staff. Contractor's employees, subcontractors, or agents shall be properly trained to meet or exceed any specified licensing, training and/or certification applicable to their profession. Upon request, Contractor shall furnish proof thereof.

11. SCHEDULING AND WORK PLANNING; PROGRESS REPORTING

- (a) **Progress Reports.** Contractor shall provide to the District update/status reports as provided in the Statement of Work. Reports will provide detail on progress of the Work and outline any potential issues affecting completion or the overall schedule. Reports may be submitted in any form agreed to by District's Project Manager and Contractor, and may include emails, memos, and letters.
 - 1. **Progress Meetings.** The District may conduct progress meetings with Contractor on a frequency to be determined by the District. In such event, Contractor shall make available its Project Manager and other appropriate personnel to discuss matters pertinent to the Work.
 - 2. **Failure to Meet Schedule.** If progress of the Work falls five percent or more behind schedule, except as a result of District-approved delays, Contractor shall take all necessary steps to augment the work effort to get the project back on schedule. Should the progress of the Work fall ten percent or more behind schedule, the District may advise Contractor through a "cure" notice that this Agreement is subject to termination for cause if the failure is not cured within the time frame specified in said notice.

12. AMENDMENTS; EMERGENCY CHANGES IN WORK

- (a) **Amendments.** The parties may not amend this Agreement except in writing. Modifications that alter, add to, or deduct from the Work, or otherwise modify the terms of this Agreement, shall be implemented through a change order or formal amendment, specifying the nature of the change and any associated change in the Total Compensation and/or Completion Date. The District's Project Manager may also issue a District Supplemental Instruction (DSI) form (Attachment C) to authorize minor adjustments to the Work that are consistent with the purpose of the Work. Both parties must sign the DSI. A DSI may not be used to change the Total Compensation, quantity, quality or the Completion Date of the Work, or to change or modify the Agreement.

(b) **Emergency Changes in Work.** In the event an emergency endangering life or property requires immediate action, the District may give Contractor an oral instruction to proceed with an emergency change in the Work, which will be confirmed in writing within five days. Within 15 days after commencement of the emergency change in the Work, Contractor shall provide the District with a written estimate of any increased costs or delays as a result thereof. **Failure to so notify the District constitutes a waiver of any right to an extension of time or increase in compensation.** Within 15 days after receipt of Contractor's estimate, the parties shall negotiate a Change Order. If unable to reach agreement, disputed issues shall be resolved pursuant to the dispute resolution procedure. In no event shall Contractor decline to perform the emergency change in the Work.

13. **TERMINATION.** The District may terminate this Agreement without cause upon ten days' written notice. In such event, Contractor shall be compensated for all Work performed in accordance with this Agreement to the effective date of termination. Alternatively, in the event of any material breach hereof, the District may terminate this Agreement for cause on ten days' written notice and opportunity to cure. Upon termination with or without cause, the District may take possession of and finish the Work by whatever means it deems expedient. Contractor may terminate this contract only if the District fails to pay sums when due. In such event, Contractor shall provide the District no less than ten days' prior written notice of its intention to terminate and afford the District an opportunity to cure the grounds for termination within said period.

ADDITIONAL PROVISIONS (In Alphabetical Order)

BUSINESS DAY: Monday through Friday, excepting those holidays observed by the District – New Years Day, Martin Luther King Day, Memorial Day, Independence Day, Labor Day, Veteran's Day, Thanksgiving (and Friday), and Christmas Day.

CHANGE ORDER: A written agreement of the parties after the Commencement Date to amend this Agreement so as to modify the Statement of Work or the Total Compensation or provide for an extension of time.

CONTRACTOR: Contractor, its officers, employees, agents, successors, and assigns.

CONTRACTOR's PROJECT MANAGER: The individual designated by the Contractor to be responsible for overall coordination, oversight, and management of the Work for Contractor.

14. **ACCESS.** The District will provide sufficient access to accomplish any Work performed on District property. Land access to the work area shall be restricted to the route designated by the District. Access routes shall be used only for the Work. Contractor shall not disturb lands or waters outside the area of activity, except as authorized by the District. Contractor shall keep all gates to District lands or easements closed and locked in accordance with District specifications when not in use, and shall immediately notify the District when a gate has become impaired due to vandalism or other cause. Contractor shall be responsible for providing lock(s) to District properties, unless otherwise stated in the Statement of Work.

15. **AUDIT; ACCESS TO RECORDS.** Contractor must preserve its books and other records involving transactions related to this Agreement and provide the District, or its duly authorized representatives, access and necessary facilities to inspect and audit those records for five years after the receipt of funds. If an examination or audit is performed, Contractor must continue to maintain all required records until such audit has been completed and all questions arising from it are resolved. Contractor shall refund any payment(s) that are found to not constitute allowable costs based upon an audit examination.

16. **CIVIL RIGHTS.** Pursuant to chapter 760, Fla. Stat., Contractor shall not discriminate against any employee or applicant for employment because of race, color, religion, sex, pregnancy, or national origin, age, handicap, or marital status.

17. COOPERATION WITH THE INSPECTOR GENERAL, PURSUANT TO §20.055(5) FLA.

STAT. Contractor and any subcontractors understand and will comply with their duty, pursuant to §20.055(5), Fla. Stat., to cooperate with the inspector general in any investigation, audit, inspection, review, or hearing.

18. COORDINATION WITH THE DISTRICT AND OTHER DISTRICT CONTRACTORS

- (a) The District may let other contracts in connection with the Work. Wherever work done by the District or another District contractor is contiguous to Contractor's Work, the respective rights of the various interests shall be established by the District so as to secure completion of the Work. Contractor shall arrange its Work so as not to interfere with the District or other District contractors and join its Work to that of others in a proper manner, and in accordance with the intent of the Statement of Work. Contractor shall perform its Work in the proper sequence in relation to that of other District contractors, as may be directed by the District. Contractor shall afford other District contractors reasonable opportunity for introduction and storage of their materials and execution of their work, and shall properly conduct and coordinate its Work with theirs. Contractor shall take into account all contingent work to be done by others and shall not plead its want of knowledge of such contingent work as a basis for delay or non-performance. Contractor shall be liable for any damage it causes to the work performed by other District contractors.
- (b) If any part of the Work depends for proper execution or results upon the work of other District contractors, Contractor shall inspect and promptly report any defects in the other contractors' work that render it unsuitable for Contractor's Work. Failure to so inspect and report shall constitute an acceptance of the other contractors' work as fit and proper for the reception of its Work, except as to defects which may develop in the other contractors' work after execution of the Work.

19. CORRELATION AND INTENT OF DOCUMENTS; QUESTIONS OR ISSUES REGARDING PERFORMANCE OF THE WORK

- (a) This Agreement and all attachments are complementary. What is called for by one is as binding as if called for by all. The intent is to include all labor and materials, equipment, transportation, and incidentals necessary for the proper and complete execution of the Work. Materials or work described in words, which so applied have a well-known technical or trade meaning, shall be held to refer to such recognized standards.
- (b) It is the District's intention to fully assist Contractor in the successful performance of the Work and to respond in a timely manner to questions or issues that arise. Contractor should discuss any questions or issues with the District's Project Manager and communicate such questions or issues in writing when required by this Agreement. The District shall respond through its Project Manager.

20. DISPUTE RESOLUTION

- (a) **During the course of work.** In the event any dispute arises during the course of the Work, Contractor shall fully perform the Work in accordance with the District's written instructions and may claim additional compensation. Contractor is under a duty to seek clarification and resolution of any issue, discrepancy, or dispute by submitting a formal request for additional compensation, schedule adjustment, or other dispute resolution to the District's Project Manager no later than 15 days after the precipitating event. If not resolved by the Project Manager within five business days, the Project Manager shall forward the request to the District's Office of General Counsel, which shall issue a written decision within 15 days of receipt. This determination shall constitute final action of the District and shall then be subject to judicial review upon completion of the Work. **Contractor shall proceed with the Work in accordance with said determination. This shall not waive Contractor's position regarding the matter in dispute.**

(b) **Invoices.** In the event the District rejects an invoice as improper, and the Contractor declines to modify the invoice, the Contractor must notify the District in writing within ten days of receipt of notice of rejection that the Contractor will not modify the invoice and state the reason(s) therefor. Within five business days of receipt of such notice, if not informally resolved through discussion with the District Project Manager, the Project Manager shall forward the disputed invoice and the Contractor's written response to the District's Office of General Counsel. The matter shall then proceed as described in subsection (a), above.

21. **DIVERSITY REPORTING.** The District is committed to the opportunity for diversity in its procurement activities, and encourages its prime vendors (contractors and suppliers) to make a good faith effort to ensure that women and minority-owned business enterprises (W/MBE) are given the opportunity for maximum participation as sub-contractors. The District will assist Contractor by sharing information on W/MBEs. Contractor shall provide with each invoice a report describing the company names for all W/MBEs, the type of minority, and the amount spent with each at all levels. The report will also denote if there were no W/MBE expenditures.

22. **DUTY TO INSPECT AND REPORT DEFICIENCIES IN PLANS AND SPECIFICATIONS**

(a) For any Work that is dependent upon conditions at the worksite, Contractor's acceptance of contract award represents and warrants that Contractor has inspected and satisfied itself concerning the nature and location of the Work and general and local conditions, including, without limitation: (1) conditions affecting transportation, disposal, handling, and storage of materials; (2) availability and quality of labor; (3) availability and condition of roads; (4) climatic conditions and seasons; (5) hydrology of the terrain; (6) topography and ground surface conditions; (7) nature and quantity of surface materials to be encountered; (8) equipment and facilities needed preliminary to and during the Work; and (9) all other matters that can affect the Work and the cost thereof. Contractor's failure to acquaint itself with such conditions will not relieve it from its responsibility for properly estimating the time required or cost of performing the Work. Where the District has investigated subsurface conditions, this data may be provided to Contractor or is available upon request. Contractor must either seek clarification concerning the data or assume the responsibility for its interpretation.

(b) If Contractor discovers hidden or subsurface conditions that differ materially from those normally expected or indicated in the technical specifications, Contractor shall immediately, and before such conditions are disturbed, notify the District in writing of: (1) subsurface or latent physical conditions differing materially from those indicated in the technical specifications, or (2) unknown physical conditions of an unusual nature differing materially from those ordinarily encountered and generally recognized as inherent in work of the character provided for herein. The District shall promptly investigate the conditions and determine whether they materially differ so as to cause an increase or decrease in Contractor's cost. Where the differing site conditions materially impact Contractor's cost, an equitable adjustment shall be made and the Agreement modified accordingly. No claim will be allowed if Contractor fails to provide the required notice.

(c) If Contractor in the course of the Work finds any defect in the plans and specifications, including, but not limited to, any discrepancy between the drawings and the physical conditions at the worksite, or any errors or omissions in the drawings or in the layout, as given by points and instructions, it shall immediately inform the District in writing, which shall be promptly verified by the District. Any Work done after such discovery, until authorized, will be done at Contractor's risk as to cost overruns and modifications necessary to correct deficiencies in the Work. To ensure the proper execution of its subsequent Work, Contractor shall measure Work already in place or completed and shall immediately report any discrepancy between the executed Work and the drawings or other specifications.

23. **GOVERNING LAW, VENUE, ATTORNEY'S FEES, WAIVER OF RIGHT TO JURY TRIAL.** This Agreement shall be construed according to the laws of Florida and shall not be construed more strictly against one party than against the other because it may have been drafted by one of the parties. As used herein, "shall" is always mandatory. In the event of any legal proceedings

arising from or related to this Agreement: (1) venue for any state or federal legal proceedings shall be in Orange County; (2) each party shall bear its own attorney's fees, including appeals; (3) for civil proceedings, the parties hereby consent to trial by the court and waive the right to jury trial.

24. **INTEREST IN THE BUSINESS OF CONTRACTOR; NON-LOBBYING.** Contractor certifies that no officer, agent, or employee of the District has any material interest, as defined in chapter 112, Fla. Stat., either directly or indirectly, in the business of Contractor to be conducted under this Agreement, and that no such person shall have any such interest at any time during the term of this Agreement. Pursuant to §216.347, Fla. Stat., monies received from the District pursuant to this Agreement shall not be used to lobby the Florida Legislature or any other state agency.
25. **INDEPENDENT CONTRACTOR.** Contractor is an independent contractor. Neither Contractor nor Contractor's employees are employees or agents of the District. Contractor controls and directs the means and methods by which the Work is accomplished. Contractor is solely responsible for compliance with all labor, health insurance (Patient Protection and Affordable Care Act 42 U.S.C. §§ 18001, et seq.), and tax laws pertaining to Contractor, its officers, agents, and employees, and shall indemnify and hold the District harmless from any failure to comply with such laws.
26. **LIENS.** Neither final payment nor payment of any part of the retainage shall become due until Contractor delivers to the District releases of all labor and material cost liens arising from Contractor's performance of the Work, including Contractor and any subcontractor(s), and an affidavit by Contractor stating that the releases and receipts include all labor and material costs for which a lien could be filed. If any subcontractor refuses to furnish Contractor a release or a receipt in full, Contractor may furnish to the District a bond satisfactory to the District, indemnifying the District against any such potential lien. If any lien or potential lien remains unsatisfied, the District may discharge the same forthwith and deduct the cost thereof from any amounts due to Contractor. In the event Contractor has been fully paid or the amount of such lien exceeds the amount due to Contractor, Contractor shall refund to the District all monies that the District paid in discharging such lien, including all costs and a reasonable attorney's fee. The discharging of such a lien by the District shall not constitute a waiver of any claims or defenses that Contractor may have against the lienor.
27. **NUISANCE.** Contractor shall exercise every reasonable means to avoid creating or continuing a public or private nuisance resulting from the Work, including, but not limited to: (1) excessive noise associated with radio or other forms of electronic entertainment for persons at the worksite; (2) dust from construction operations, and (3) the uncontrolled flow of surface waters.
28. **PERMITS AND LICENSES; COMPLIANCE WITH LAW.** Contractor shall comply with all applicable federal, state and local laws and regulations, including those pertaining to health and safety. All materials used and work performed must conform to the laws of the United States, the state of Florida and county and municipal ordinances. Contractor represents and warrants that it is duly licensed to perform the Work in accordance with the laws of the state of Florida and the county or municipality in which the Work is to be performed. Unless otherwise specifically provided for herein, Contractor shall give to the proper authorities all required notices relative to the Work in its charge; obtain and pay for all official permits or any other licenses, including any and all professional licenses required by the nature of the Work; and furnish any bonds, security, or deposits required to permit performance of the Work. Contractor is responsible for the resolution of any issues resulting from a finding of noncompliance by any regulatory agencies, due to the Contractor's failure to comply with applicable regulatory requirements, including all costs for delays, litigation, fines, or other costs.
29. **PETROLEUM STORAGE TANKS.** Any petroleum storage tanks with a capacity of 55 gallons or greater that Contractor brings onto District property must be either double-walled or kept within secondary containment that will contain 110% of the tank volume.

30. PUBLIC RECORDS

- (a) Contractor is responsible for identifying confidential trade secret information as such upon submittal to the District. Notwithstanding any other provision hereof, the District shall not be liable to Contractor for release of confidential information not identified as such upon submittal. If the District receives a public records request that requests information claimed to be confidential by Contractor, the District shall take such steps as are necessary to comply with chapter 119, Fla. Stat., while protecting the confidentiality of trade secret information. In the event of a dispute as to whether the requested information is a trade secret, Contractor shall be liable for all costs incurred by the District resulting from the dispute, including any court costs and attorney's fees. The calculation of those costs shall not include costs that are charged to the public records requestor.
- (b) Contractor shall comply with Florida Public Records law under Chapter 119, Fla. Stat. Records made or received in conjunction with this Agreement are public records under Florida law, as defined in §119.011(12), Fla. Stat. Contractor shall keep and maintain public records required by the District to perform the services under this Agreement.
- (c) If Contractor meets the definition of "Contractor" found in §119.0701(1)(a), Fla. Stat.; [i.e., an individual, partnership, corporation, or business entity that enters into a contract for services with a public agency and is acting on behalf of the public agency], then the following requirements apply:
 - (i) Pursuant to §119.0701, Fla. Stat., a request to inspect or copy public records relating to this Agreement for services must be made directly to the District. If the District does not possess the requested records, the District shall immediately notify the Contractor of the request, and the Contractor must provide the records to the District or allow the records to be inspected or copied within a reasonable time. If Contractor fails to provide the public records to the District within a reasonable time, the Contractor may be subject to penalties under s. 119.10, Fla. Stat.
 - (ii) Upon request from the District's custodian of public records, Contractor shall provide the District with a copy of the requested records or allow the records to be inspected or copied within a reasonable time at a cost that does not exceed the cost provided in Chapter 119, Fla. Stat., or as otherwise provided by law.
 - (iii) Contractor shall identify and ensure that all public records that are exempt or confidential and exempt from public records disclosure requirements are not disclosed except as authorized by law for the duration of the Agreement term and following completion of the Agreement if the Contractor does not transfer the records to the District.
 - (iv) Upon completion of the Agreement, Contractor shall transfer, at no cost to District, all public records in possession of Contractor or keep and maintain public records required by the District to perform the services under this Agreement. If the Contractor transfers all public records to the District upon completion of the Agreement, the Contractor shall destroy any duplicate public records that are exempt or confidential and exempt from public disclosure requirements. If the Contractor keeps and maintains public records upon completion of the Agreement, the Contractor shall meet all applicable requirements for retaining public records. All records that are stored electronically must be provided to the District, upon request from the District's custodian of public records, in a format that is accessible by and compatible with the information technology systems of the District.

(d) IF THE CONTRACTOR HAS QUESTIONS REGARDING THE APPLICATION OF CHAPTER 119, FLA. STAT., TO THE CONTRACTOR'S DUTY TO PROVIDE PUBLIC RECORDS RELATING TO THIS CONTRACT, CONTACT THE DISTRICT'S CUSTODIAN OF PUBLIC RECORDS AT:

District Clerk

St. Johns River Water Management District
4049 Reid Street
Palatka, Florida 32177-2571
(386) 329-4127
clerk@sjrwmd.com

31. **REMEDIES FOR NON-PERFORMANCE.** In the event of incomplete or damaged Work caused by Contractor's failure of performance, the District may terminate this Agreement for cause. Alternatively, the District, in its sole discretion and judgment, may allow Contractor to correct the deficiency at its expense. If the District determines that it is not in its best interest for Contractor to correct the deficiency, the District may pursue any or all of the following remedies, in whole or in part: (1) accept the Work as is and deduct the reasonable value of the deficient Work from the Total Compensation; (2) complete the Work through the utilization of District employees and deduct the cost thereof from the Total Compensation; (3) contract with a third party to complete the deficient Work and deduct the cost thereof from the Total Compensation. In addition to the remedies set forth above, the District may avail itself of any statutory and/or common law remedies. Delay or failure by the District to enforce any right or remedy hereunder shall not impair, or be deemed a waiver of, any such right or remedy, or impair the District's rights or remedies for any subsequent breach of this Agreement.
32. **SAFETY.** For any Work that is to be performed on premises that are owned or controlled by the District (the Premises), Contractor has the sole and exclusive duty for the safety of the premises. Contractor shall provide and maintain sufficient protection for the safety of its employees and other persons who may utilize the Premises, and prevent damage to District property, materials, and equipment. Contractor shall at all times enforce strict discipline and good order among its employees and shall not employ any unfit person or anyone not skilled in the work assigned. Neither Contractor nor its subcontractors shall allow or cause to be allowed any hunting or any weapons, animals, alcohol, or drugs, on or from the Premises or adjacent property. Contractor employees shall not park their vehicles or store equipment or materials adjacent to roads where it may be a hazard to traffic. A clear distance of at least 30 feet from the edge of the pavement or right-of-way shall be kept free of any obstacles unless otherwise authorized by the District. Contractor shall ensure that only authorized personnel are allowed on the worksite and shall post notices warning both employees and the public of all safety hazards created by Contractor.
33. **USE OF COMPLETED PORTIONS OF THE WORK.** The District shall have the right to take possession of and use any completed or partially completed portions of the Work, notwithstanding the fact that the time for completing the entire Work or such portions may not have expired. Such taking of possession and use will not be deemed an acceptance of any Work not completed. If such possession and use increases the cost of or delays the Work, Contractor shall be entitled to a Change Order for extra compensation, or extension of time, as necessary, to offset the effect of such prior possession and use.
34. **WORK SCHEDULE.** For construction or other services upon District property, no Work shall be accomplished on official holidays or weekends unless approved in advance by the District Project Manager. Unless otherwise approved by the District Project Manager, Contractor's work hours on District property shall not commence before 7:00 a.m. and shall conclude on or before 6:00 p.m. All requests to change the schedule shall be coordinated with the District a minimum of 24 hours in advance of the change and confirmed in writing.

IN WITNESS WHEREOF, the St. Johns River Water Management District has caused this Agreement to be executed on the day and year written below in its name by its Executive Director, or duly authorized designee, and Contractor has caused this Agreement to be executed on the day and year written below in its name by its duly authorized representatives, and, if appropriate, has caused the seal of the corporation to be attached. This Agreement may be executed in separate counterparts, which shall not affect its validity. Upon execution, this Agreement constitutes the entire agreement of the parties, notwithstanding any stipulations, representations, agreements, or promises, oral or otherwise, not printed or inserted herein. This Agreement cannot be changed by any means other than written amendments referencing this Agreement and signed by all parties.

ST. JOHNS RIVER WATER
MANAGEMENT DISTRICT

CONTRACTOR

By: _____
Ann B. Shortelle, Ph.D., Executive Director

By: _____

Typed Name and Title

Date: _____

Date: _____

- Attachments:
- Attachment A — Statement of Work/Technical Specifications
 - Attachment B — Insurance Requirements
 - Attachment C — District’s Supplemental Instructions (sample)