



THE CITY OF
TALLMADGE
HISTORY MOVING FORWARD

SPECIFICATIONS & PROPOSAL:

FIBER CONDUIT INSTALLATION TO PHASE 5 TALLMADGE RESERVE

Bids due: *August 31, 2022 @ 10 a.m.*

Submitted By:

Company Name

Street Address

City

State

Zip

Contact Person

Phone No.

Email Address

David G. Kline, Mayor
Michael Rorar, Director of Public Service

46 North Avenue, Tallmadge, Ohio 44278

Phone 330-633-0854 ■ Fax 330-633-1359

**City of Tallmadge Department of Public Service
Invitation to Bid**

Sealed proposals will be accepted in the Public Service Department, City of Tallmadge, 46 North Avenue, Tallmadge, Ohio, 44278 until 10:00 a.m. Wednesday, August 31, 2022. (City Hall is open for public access Monday thru Friday from 9:00 a.m. to 3:00 p.m.) Bids being opened immediately thereafter in the Council Chambers of the Municipal Building for:

FIBER CONDUIT INSTALLATION TO PHASE 5 TALLMADGE RESERVE

Detailed information, proposal forms and complete specifications may be obtained from the City of Tallmadge website at <https://www.tallmadge-ohio.org/bids>

Bidders must use the forms available on the website as no other will be accepted. Proposals must include a price for each item in the Bid Proposal form. Incomplete proposals will be considered informal and will not be considered. Each bid must contain the full name of every person or company participating in the bid.

Each bid must be accompanied by a Bid Guaranty, in accordance with Section 153.54 of the Ohio Revised Code. Each bidder shall submit either a Bid Guaranty bond in the amount of 100%, OR a certified check in the amount of 10% of the proposal, made payable to the CITY OF TALLMADGE. Should any bid not be awarded or be rejected, such check or bond will be returned to the bidder or bidders after the execution of the contract.

The award of this contract shall be to the lowest and best bidder. The City of Tallmadge reserves the right to reject any or all bids and to accept the bid(s) deemed most beneficial to the City of Tallmadge.

The bidder is responsible for monitoring the above-named website for any official addenda.

Please contact Tina Fiocca in the Public Service Department at tfiocca@tallmadge-ohio.org if you have any questions regarding this bid.

Project Estimate \$70,000

Michael Rorar
Director of Public Service
Ordinance 2022-40

Published in the Akron Beacon Journal:

August 14, 2022
August 21, 2022

Table of Contents and Bidder's Checklist

A complete bid packet will consist of the items listed below.

Complete this checklist to confirm the items required in your bid. Place a checkmark or "X" next to each item that you are submitting to the City of Tallmadge. Failure to submit the listed documents may be cause for rejection of your bid. This checklist should be returned with your bid.

- _____ Cover sheet (Page 1)
- _____ Invitation to Bid (Page 2)
- _____ Table of Contents and Bidder's Checklist (Page 3)
- _____ Section I: Instruction to Bidders (Pages 4 - 5)
- _____ Section II: Bid Forms (Pages 6 - 21)
 - _____ Bid Form List
 - _____ Bid Form 1: Note
 - _____ Bid Form 2: Bid Guaranty and Contract Bond
 - _____ Bid Form 3: Non-Collusion Affidavit
 - _____ Bid Form 4: Statement of Non – Liability for Delinquent Personal Property Taxes
 - _____ Bid Form 5: Statement of Liability for Delinquent Personal Property Taxes
 - _____ Bid Form 6: Certification of Drug Free Workplace
 - _____ Bid Form 7: Certification for Local Preference Certification
 - _____ Bid Form 8: Affidavit in Compliance with Section 3517.13
 - _____ Bid Form 9: Independent Contractor Anti-Bias Disclosure
 - _____ Bid Form 10: Certification of No Personal Interest
 - _____ Bid Form 11: OPERS Independent Worker/ Contractor Acknowledgment Form
 - _____ Bid Form 12: OPERS Form
- _____ Section III: Bid Specifications (Pages 22-26)
- _____ Section IV: Proposal and Signature Pages (Page 27)
- _____ Section V: Tallmadge Codified Ordinance (Page 28)
- _____ Section VI: Equipment List (to be submitted with bid) (Page 29)
- _____ Section VII: Bidder References (to be submitted with bid) (Page 30)
- _____ Section VIII: Experience of Management/Supervisory Personnel (Page 31)

SECTION I: INSTRUCTIONS TO BIDDERS

All pages of the Bid Proposal, Specifications and Contract Documents must be intact and included in the bid submittal. Bidders must use the forms provided on the City of Tallmadge website as none other will be accepted.

The City of Tallmadge does encourage bidders to submit all bid forms with their bids.

Submit all bids to the City of Tallmadge Public Service Department, 46 North Avenue, Public Service Department, Tallmadge, Ohio 44278 according to the instructions in the Invitation to Bid posted on the City of Tallmadge's website at <https://www.tallmadge-ohio.org/bids>

Bids should be in a sealed envelope marked with project title and the name and address of bidder and reach the Public Service Department, no later than 10:00 a.m. on Wednesday August 31, 2022. The Public Service date/time stamp is the official date/time used for the deadline of the submission of bids. The City will disqualify any bid not received on or before 10:00 AM local time on Wednesday August 31, 2022.

The City reserves the right to waive any informality in any proposal, and to reject any or all bids. The City also reserves the right not to enter into any contract as a result of this invitation for bid.

All addendums will be posted on the City website through Vendor Registry. It is the bidder's responsibility to check this site on a regular basis. The City will not be responsible for any information not viewed by bidders. All bidders should register with www.vendorregistry.com so that the City has all the necessary vendor information.

In reviewing bids to determine who is the lowest and best, the City will take into consideration the extent to which the bid conforms to the bid specifications and the qualifications of the bidder to satisfactorily implement the requirements of the Contract. The City specifically reserves the right to reject any bids for which the bidder fails to demonstrate the ability to provide the service required in a responsible manner.

Any bidder may withdraw his bid, by written request, at any time prior to the deadline set for the bid opening. Please be advised, the City of Tallmadge may impose a \$500.00 penalty to any bidder that withdraws his bid after the bid opening and prior to a contract award(s).

Bid will be awarded to the lowest and best bidder. The City will be the judge of the factors and will make the award accordingly. Should the successful bidder not be able to provide the required services, the City reserves the right to request service from other sources.

After award of the bid, by the City of Tallmadge, the successful bidder will receive an official award notification from the City. The signed contract will represent agreement between the City and the successful bidder (all terms of the bid specifications and any applicable addenda will apply).

The Contractor shall be required to furnish to the City of Tallmadge, evidence showing insurance coverage to be in force throughout the term of the contract. The Contractor shall carry Comprehensive General Liability and Auto Liability Insurance to cover damages for which the contractor may be legally responsible due to bodily injury or property damage. The contractor shall provide to the City of Tallmadge a certificate of insurance showing \$1,000,000.00 Combined Single Limit and \$2,000,000.00 Aggregate Coverage and Workers Compensation Insurance. The City of Tallmadge must be included as an additional insured.

The Contractor covenants to save, defend, hold harmless, and indemnify the City, and all of its officers, departments, agencies, agents, and employees (collectively the "City") from and against any and all claims, losses, damages, injuries, fines, penalties, costs (including court costs and attorney's fees), charges, liability, or exposure, however caused, resulting from, arising out of, or in any way connected with the Contractor's intentional, negligent, or grossly negligent acts or omissions in performance or nonperformance of its work called for by the Contract Documents.

After satisfactory completion of services, the Contractor shall forward invoice(s) to the following address: The City of Tallmadge, Public Service Department, 46 North Ave., Tallmadge, Ohio 44278.

SECTION II: BID FORMS

- _____ Bid Form 1: Note
- _____ Bid Form 2: Bid Guaranty and Contract Bond
- _____ Bid Form 3: Non-Collusion Affidavit
- _____ Bid Form 4: Statement of Non – Liability for Delinquent Personal Property Taxes
- _____ Bid Form 5: Statement of Liability for Delinquent Personal Property Taxes
- _____ Bid Form 6: Certification of Drug Free Workplace
- _____ Bid Form 7: Certification for Local Preference
- _____ Bid Form 8: Affidavit in Compliance with Section 3517.13
- _____ Bid Form 9: Independent Contractor Anti-Bias Disclosure
- _____ Bid Form 10: Certification of No Personal Interest
- _____ Bid Form 11: OPERS Independent Worker/ Contractor Acknowledgment Form
- _____ Bid Form 12: OPERS Form

NOTE

The bidder hereby agrees that the Public Service Director has the right to reject any or all bids and to waive informality in any bid and that the bidder shall not dispute the correctness of the quantities used in computing the lowest and best bidder.

(Signature of Officer, Partner or Owner)

(Date)

(Business Address of Bidder)

(Business Phone Number of Bidder)

CERTIFIED CHECK OR BID BOND

Certified check or bid bond in the amount of: _____
_____ on
(State Amount)

(Name of Band or Bonding Company)

deposited herewith.

(Bidder)

(Date)

ALL BIDS NOT IN CONFORMITY WITH THESE PROVISIONS WILL BE REJECTED.

BID GUARANTY/ CONTRACT BOND/ MAINTENANCE BOND

KNOW ALL MEN BY THESE PRESENTS, that we the undersigned _____
_____ as Principal, and
_____ as Sureties, are hereby held and firmly bound unto the

CITY OF TALLMADGE, OHIO

as Obligee in the penal sum of the dollar amount of the Bid submitted by the Principal to the Obligee on the _____ day of _____, 20 _____ to undertake the Project known as:

The penal sum referred to herein shall be the dollar amount of the Principal's Bid to the Obligee, incorporating any additive or deductive alternate proposals made by the Principal on the date referred to above to the Obligee, which are accepted by the Obligee. In no case shall the penal sum exceed the amount of _____ dollars (\$_____).(If the foregoing blank is not filled in, the penal sum will be the amount of the Principal's Bid, including alternates. Alternatively, if the blank is filled in, the amount stated must not be less than the full amount of the Bid including alternates, in dollars and cents. A percentage is not acceptable.) For the payment of the penal sum well and truly to be made, we hereby jointly and severally bind ourselves, our heirs, executors, administrators, successors, and assigns.

THE CONDITION OF THE ABOVE OBLIGATION IS SUCH, that whereas the above name Principal has submitted a Bid for _____
_____ for the City of Tallmadge, Ohio;

NOW THEREFORE, if the Obligee accepts the Bid of the Principal and the Principal fails to enter into a proper Contract in accordance with the Bid and the other contract documents; and in the event the Principal pays to the Obligee the difference not to exceed ten percent of the penalty hereof between the amount specified in the Bid and such larger amount for which the Obligee may in good faith Contract with the next lowest bidder to perform the work covered by the Bid; or in the event the Obligee does not award the Contract to the next lowest bidder and resubmits the Project for bidding, the Principal pays to the Obligee the difference not to exceed ten percent of the penalty hereof between the amount specified in the Bid, or the costs, in connection with the resubmission of printing new contract documents, required advertising, and printing and mailing notices to prospective bidders, whichever is less, then this obligation shall be null and void, otherwise to remain in full force and effect; if the Obligee accepts the Bid of the Principal and the Principal within ten days after the awarding of the Contract enters into a proper Contract in accordance with the Bid and the other contract documents, which said Contract is made a part of this Bond the same as though set forth herein;

NOW ALSO, if the said Principal shall well and faithfully do and perform the things agreed by said Principal to be done and performed according to the terms of said Contract;

and shall pay all lawful claims of Subcontractors, materialmen, and laborers, for labor performed and materials furnished in the carrying forward, performing, or completing of said Contract; we agreeing and assenting that this undertaking shall be for the benefit of any materialman or laborer having a just claim, as well as for the Obligee herein; then this obligation shall be void; otherwise the same shall remain in full force and effect; it being expressly understood and agreed that the liability of the Surety for any and all claims hereunder shall in no event exceed the penal amount of this obligation as herein stated.

NOW, THEREFORE, THE CONDITION OF THIS OBLIGATION is such that a maintenance guarantee, with good and sufficient surety, in the amount of ten percent (10%) of the amount of the performance guarantee for a period of two (2) years from and after the date of completion and acceptance by the Owner, replace any and all defects arising in the Work, whether resulting from defective materials or defective workmanship, after such period this obligation shall be null and void; otherwise it will remain in full force and effect.

The said Surety hereby stipulates and agrees that no modifications, omissions, or additions, in or to the terms of the said Contract or in or to the Drawings or Specifications therefor shall in any wise affect the obligations of said Surety on its Bond.

IN WITNESS WHEREOF, we have hereunto set our hands and seal this _____ day of _____, 20 _____.

_____Principal

By _____

_____ Surety

By _____

Address _____

Phone No. _____

(SEAL)

IMPORTANT - Surety companies executing Bonds must appear on the Treasury Department's most current list (Circular 570 as amended) and be authorized to transact business in the state where the Project is located.

CERTIFICATION OF
DRUG FREE WORKPLACE

BIDDER'S NAME: _____

ADDRESS:

CITY, STATE:

Project:

CERTIFICATION

The undersigned, being a duly authorized agent of the Bidder does certify that the following facts are true:

1. Bidder has published and provided to employees notice that the manufacture, use, possession, or distribution of drugs in the workplace is prohibited, as well as a specification of the disciplinary action that may be taken against employees who violate that prohibition.
2. It is the policy of the Bidder that any employee convicted of violating a criminal drug statute occurring in the workplace is required to notify the employer of said conviction within five (5) days after such conviction.
3. Bidder has published notice specifying the sanctions for or requiring satisfactory participation in a drug abuse assistance or rehabilitation program by an employee convicted of violating a criminal drug statute occurring in the workplace.
4. Bidder has implemented a program for the distribution of information on drug abuse awareness and the availability of counseling and referral services.

I further certify and understand that the City of Tallmadge, pursuant to Ordinance 142-1994, can enter into a contract resulting from the competitive bidding process only with those Bidders who provide a drug free workplace by meeting the above requirements.

DATE: _____

Signature: _____

Title: _____

**CERTIFICATION FOR
LOCAL PREFERENCE**

The undersigned bidder does hereby certify that his principal place of business is within the corporate limits of the City of Tallmadge, Ohio or within the Brimfield / Tallmadge JEDD Area and that he qualifies as a **"local business"** by complying with the following policy as established by Ord. 126-97 Section 143.06:

Local Preference Policy

A. DEFINITIONS:

1. "Business" means a domestic corporation, sole proprietorship, partnership, or joint venture whose principal place of business is located in Tallmadge, Ohio or is located within the area designated as a Joint Economic Development District as established by the City of Tallmadge and the Township of Brimfield. If one party to joint venture has its principal place of business in Tallmadge, Ohio, or is located within the Joint Economic Development District, the joint venture shall be considered as having its principal place of business in Tallmadge. No business as defined herein shall benefit from the local preference policy unless it is participating in the JEDD by withholding and paying City income tax.

2. "Bidder" means the respondent to invitations to bid and/or to requests for proposals.

B. Bidders having established their principal place of business in Tallmadge, Ohio for two successive calendar years immediately preceding the bid opening date or proposal date, may be preferred as lowest if their bid does not exceed the lowest bid by more than 3%, not to exceed ten thousand dollars (\$10,000) of the apparent low bid.

C. To qualify for local preference bidders shall include the following on their bid or proposal documents:

1. Certification that "The bidder of offer hereby certifies that its principal place of business is in Tallmadge, Ohio and has been for at least two successive years immediately preceding the opening date herein".

2. Location of principal place of business.

3. Date of business establishment

4. If the bid is for a City vehicle or motor vehicle or accessory, the bidder's price shall be the same as or lower than the State Purchasing Program price.

D. Each bidder shall have only one principal place of business.

E. Local preference may be applied as provided herein where prohibited by state or federal law.

F. Local preference may be applied in considering the lowest bid and shall not waive or nullify evaluation of bidders which are responsive and responsible or lowest and best.

G. In determining the qualifications of bidders for supplies, commodities, materials, equipment, furnishings or general services as lowest responsive and responsible or lowest and best bidder, the Board of Control shall exercise a preference of local bidders as provided for herein. The local preference shall apply to contracts for the building, repair or renovation of public buildings or improvements

BIDDER'S NAME _____ DATE BUSINESS ESTABLISHED _____

Location of principal place of business _____

Successive years at this location immediately prior to bid opening date: _____

DATED _____ Signed _____

AFFIDAVIT IN COMPLIANCE WITH SECTION 3517.13

STATE OF OHIO
COUNTY OF _____ ss:

Personally, appeared before me the undersigned, a bidder, a representative of a bidder, a contractor or vendor on behalf of

_____ for a contract for _____
(Name of Business) (Type of Product or Service)

to be let by the City of Tallmadge, who, being duly cautioned and sworn, makes the following statement with respect to prohibited activities constituting a conflict of interest or other violations under R.C. Section 3517.13, and further states that the undersigned has the authority to make the following representation on behalf of the entity if the undersigned as an individual is not the bidder himself or herself:

1. On behalf of the corporation, business trust, estate, individual business owner, partner or owner of partnership or other unincorporated business, shareholder of an association, that all of the following persons, where applicable, are in compliance with R.C. 3517.13.
 - a. each owner of more than twenty percent of a corporation;
 - b. each individual, partnership or other unincorporated business, association, including without limitation, professional associations;
 - c. each shareholder of an association, administrator or executor of any estate and trustee of any trust, or political action committee associated with any of the foregoing;
 - d. each spouse of the above;
 - e. each child seven years of age to seventeen years of age of any of the above;
 - f. any combination of the above.
2. The undersigned further certifies that if awarded a contract as a result of competitive bidding, or request for proposals, he, she or it shall not once the contract is awarded and extending until one year following the conclusion of the contract, make as an individual, one or more campaign contributions totaling in excess of \$1,000 or collectively, contributions totaling in excess of \$2,000 (over a two year period), to the holder of the public office having ultimate responsibility for the award of the contract or to the public officer's campaign committee, including individuals or groups of individuals specified in paragraph 1, above.

Signature _____

Title _____

Sworn to before me, a notary public, and subscribed in my presence this ____ day of _____ 20____.

Notary Public _____

My Commission Expires _____

CITY OF TALLMADGE
INDEPENDENT CONTRACTOR ANTI-BIAS DISCLOSURE

1. To the best of your knowledge, do you have any prior relationship(s) with any employee, elected official, or non-elected official of the City of Tallmadge?

<input type="checkbox"/>	Yes
<input type="checkbox"/>	No

2. If you answered yes to question number 1, Please check the appropriate box(es) that describe that relationship(s)

<input type="checkbox"/>	Spouse
<input type="checkbox"/>	Child whether dependent or independent
<input type="checkbox"/>	Parent
<input type="checkbox"/>	Grandparent
<input type="checkbox"/>	Sibling
<input type="checkbox"/>	Aunt/Uncle
<input type="checkbox"/>	In-law
<input type="checkbox"/>	Step-child
<input type="checkbox"/>	Step-parent
<input type="checkbox"/>	Step-grandparent
<input type="checkbox"/>	Step-sibling
<input type="checkbox"/>	Step-aunt/Step-Uncle
<input type="checkbox"/>	Any other person related by blood or marriage and residing in the same household
<input type="checkbox"/>	Prior business relationship or business associate
<input type="checkbox"/>	Friend
<input type="checkbox"/>	Other significant relationship

1. If you answered Other significant relationship in question number 2,
please explain below:

2. Please provide below the name(s) of any and all employees of the City
of Tallmadge with whom you have any of the above relationships:

I declare (or certify, verify, or state) under penalty of perjury that the foregoing is true
and correct.

Print Name

Signature

Date

CITY OF TALLMADGE
CERTIFICATION OF NO PERSONAL INTEREST

Under penalty of perjury, I hereby certify that:

1. I am not a family member of any public official or public servant of the City of Tallmadge, unless otherwise disclosed in writing to all officers and elected officials of the city.

2. I am not a business associate of any public official or public servant of the City of Tallmadge unless otherwise disclosed in writing to all officers and elected officials of the city.

3. No officer, employee or assignee of the undersigned contractor is a family member or a business associate of the City of Tallmadge and has an ownership interest greater than 5% in the contractor's organization.

4. No owner, officer, employee, or agent of contractor's organization gave, offered or promised anything of value, including future benefits, to a public servant or public official of the City of Tallmadge, other than the consideration expressly provided for in the contract.

DATE: _____

CONTRACTOR:

Name of Organization

Signature

Title

OPERS Independent Worker/Contractor Acknowledgment Form Questionnaire

Please answer the questions below to determine if you will be required to complete the attached OPERS Independent Worker/Contractor Acknowledgment Form.

Question 1:

Are you a sole proprietor/independent contractor?

Yes. You are required to complete the attached OPERS Independent Worker/Contractor Acknowledgment Form. If you have less than 5 employees, each employee is also required to complete the form.

No. Please go to Question 2.

Question 2:

Are you a business entity with less than 5 employees?

Yes. You and each of your employees are required to complete the attached OPERS Independent Worker/Contractor Acknowledgment Form.

No. Please sign the statement below.

I have answered the above questions accurately and truthfully. Based on those answers, I will not be completing the OPERS Independent Worker/Contractor Acknowledgment Form .

Signature

Title

Printed Name

STEP 3: Acknowledgment

The public employer identified in Step 2 has identified you as an independent contractor or another classification other than a public employee. Ohio law requires that you acknowledge in writing that you have been informed that the public employer identified in Step 2 has classified you as an independent contractor or another classification other than a public employee for the services described in Step 2 and that you have been advised that contributions to OPERS will not be made on your behalf for these services.

If you disagree with the public employer's classification, you may contact OPERS to request a determination as to whether you are a public employee eligible for OPERS contributions for these services. Ohio law provides that a request for a determination must be made within five years after you begin providing personal services to the public employer, unless you are able to demonstrate through medical records to the Board's satisfaction that at the time the five-year period ended, you were physically or mentally incapacitated and unable to request a determination.

By signing this form, you are acknowledging that the public employer for whom you are providing personal services has informed you that you have been classified as an independent contractor or another classification other than a public employee and that no contributions will be remitted to OPERS for the personal services you provide to the public employer. This acknowledgment will remain valid as long as you continue to provide the same services to the same employer with no break in service regardless of whether the initial contract period is extended by any additional agreement of the parties. You also acknowledge that you understand you have the right to request a determination of your eligibility for OPERS membership if you disagree with the public employer's classification.

This form must be retained by the public employer and a copy sent to OPERS. The public employer's failure to retain this acknowledgment may extend your right to request a determination beyond the five years referenced above.

Signature _____ Today's Date ____/____/____
Do not print or type name

SECTION III: BID SPECIFICATIONS

A. SCOPE OF WORK

1. The City of Tallmadge has a residential subdivision off East Ave known as the Tallmadge Reserves. It is a Pulte Homes development with Fechko Excavating as the contractor for Phase 5.
2. The following work shall consist of furnishing all materials, equipment, and labor necessary to complete the installation of conduits and vaults through Phase 5 of the Tallmadge Reserve.
3. All work performed by the contractor will be subject to inspection by the City of Tallmadge Street and or Service Department and payment will be withheld for any work not complying with the above referenced specs until the deficiencies are corrected. Deficiencies shall be corrected at the sole expense of the contractor.
4. Contractor shall be responsible for clean-up, all parts of the work area and the removal of all material, packing, waste, debris and surplus material, to leave the area in as good a condition as when the work commenced.

B. EQUIPMENT AND PERSONNEL SPECIFICATION

Equipment, tools, and personnel to be supplied by the contractor include:

1. The contractor will supply the necessary equipment to fulfill the job such as hand tools, directional boring machine, testing equipment, trucks, etc.
2. It shall be the sole responsibility of the Contractor(s) performing services for this contract to safeguard their own materials, tools, and equipment. The City of Tallmadge shall not assume any responsibility for any damaged materials, tools, or equipment.
3. Adequate barricades shall be erected and maintained around all areas where equipment and materials are stored and used.
4. All traffic control devices will be in place prior to construction. Devices no longer needed will be removed as quickly as possible.

C. SAFETY AND LIABILITY

1. Contractor must provide manufacturer's product data including MSDS sheets.
2. Contractor must be fiber certified technician.
3. Contractor must contact Ohio Utilities Protection Services to have utilities marked before the start of the project. Call 811
4. Contractor is responsible to provide a safe workplace and to comply with OSHA and other federal, state or local health and safety regulations.
5. Contractor, its agents, successors and assigns shall comply with all rules of the Summit County Health Department and City and all applicable Ohio Department of Health orders and CDC Guidelines.
6. Contractor must follow the Ohio Manual of Uniform Traffic Control Devices (OMUTCD).
http://www.dot.state.oh.us/Divisions/Engineering/Roadway/DesignStandards/traffic/OhioMUTCD/Pages/OMUTCD2012_current_default.aspx
7. Contractor shall attest in writing with the submission of the bid that all equipment utilized during this contract is in good and serviceable condition.
8. Pedestrian traffic areas must be maintained at all times. Pedestrians will not be routed on to private property.

D. OTHER REQUIREMENTS

1. Contractor must be an installer of conduit and fiber installation for a period of 5 years or longer.
2. Contractor shall comply with all federal, state, and local laws and regulations applicable to the performance of its work under this contract including business license requirements of the City of Tallmadge.
3. Contractor shall not pull the crew off-line for work in another locale without first receiving permission from the City Service Director.
4. The contractor will notify (if applicable) the adjacent property owners a minimum of 24 hours in advance of construction.

E. AWARD PROCESS

1. Contracts will be awarded based on the sum of lowest and best bidder for conduit and installation services.
2. The Board of Control reserves the right to reject any or all bids and to accept the bid(s) deemed most beneficial to the City of Tallmadge. Agreement may be canceled by either party upon 10-day written notice.

F. QUESTIONS AND ADDENDA

1. All questions should be submitted in writing at least five (5) business days prior to the bid opening. Answers to questions will be issued in writing as official addenda no later than seventy-two (72) business hours prior to the time of the bid opening. Said addenda will become a component of the invitation to bid and should be acknowledged as received on the proposal page. Failure to acknowledge all official addenda in this manner may result in your bid being disqualified.
2. All questions should be directed to:
Tina Fiocca
City of Tallmadge Service Department
Email: tfiocca@tallmadge-ohio.org
3. Bidders are expected to and responsible for monitoring the Vendor Registry for all official addenda.
4. Oral instructions or decisions, unless confirmed by addenda, will not be considered valid, legal or binding.
5. Please be advised that when you submit a bid to the City of Tallmadge, the City will assume that an authorized representative of your company reviewed said bid to assure that the bid is correct and/or accurate.
6. Any bidder may withdraw a bid, by written request, at any time prior to the time set for the bid opening. This request must be made to Michael Rorar, Director of Public Service at mrorar@tallmadge-ohio.org If there is no withdrawal of the bid, in accordance to this procedure, the City reserves the right to enforce said bid prices(s) and/or contract(s).
7. If a bidder attempts to alter any of the terms and/or conditions of these bid specifications the City of Tallmadge may reject said bid.
8. The party submitting a bid is solely responsible for the delivery of the bid to the specified location prior to the deadline for the receipt of bids. The Public Service date/time stamp

is the official date/time used for the deadline of the submission of bids. City Hall is open to the public from 9:00 a.m. to 3:00 p.m. Monday through Friday.

G. Time of Completion and Liquidated Damages

1. The bidder shall complete work on the project and the various elements thereof 45 days from the start of the project. The bidder shall also pay as liquidated damages the sum of \$500 for each consecutive calendar day thereafter as hereinafter provided. The contractor shall continue to pay liquidated damages in the amount indicated until such time that all work is substantially complete.

H. INSTALL 1.25" CONDUIT IN OPEN CUT

1. DESCRIPTION:

All conduits shall be furnished and installed in accordance with the requirements of ODOT C&MS 625.12 and 725.051, ODOT SCD'S and ODOT TEM.

The conduit shall be installed in an open trench per Conduit Plan. The open trench work will be provided by others. Need to follow Ohio Edison Plan.

Pre-plan and coordination with contractor doing the open trench before the installing the conduit must occur.

The minimum depth of the conduit will be no less than 36" in depth from the existing grade.

Conduit needs to be 1.25" SDR 13.5, smooth wall, orange, with 1800 lbs. pull string or mule tape for each conduit.

All conduits shall be at a minimum depth of 3 feet below the existing grade and follow sheets.

Tracer wire shall be installed on (fixed to) conduit. Tracer wire needs to be 12 AWG Tracer.

2. RESTORATION:

Restoration of the trench will be done by others.

3. PAYMENT:

Basis of payment shall include all materials and labor necessary to complete the work described in this contract including any incidental items such as maintenance of traffic and mobilization.

I. VAULT INSTALLTION

1. DESCRIPTION:

Pull boxes shall comply with ODOT C&MS 625.11 and 725.06, ODOT SCD'S and ODOT TEM.

Pull boxes and pull box lids for the communication infrastructure shall be polymer concrete and 24"X 36" x 24".

The spacing installation shall conform with Section 411-5 in the ODOT TEM, which requires conduit runs limited to 200 feet between pull boxes but up to 400 feet in straight run.

Boxes shall also be located at all road crossings.

Vaults must be installed after First Energy sets the Pedestals for Transformers and hand holes for final grade.

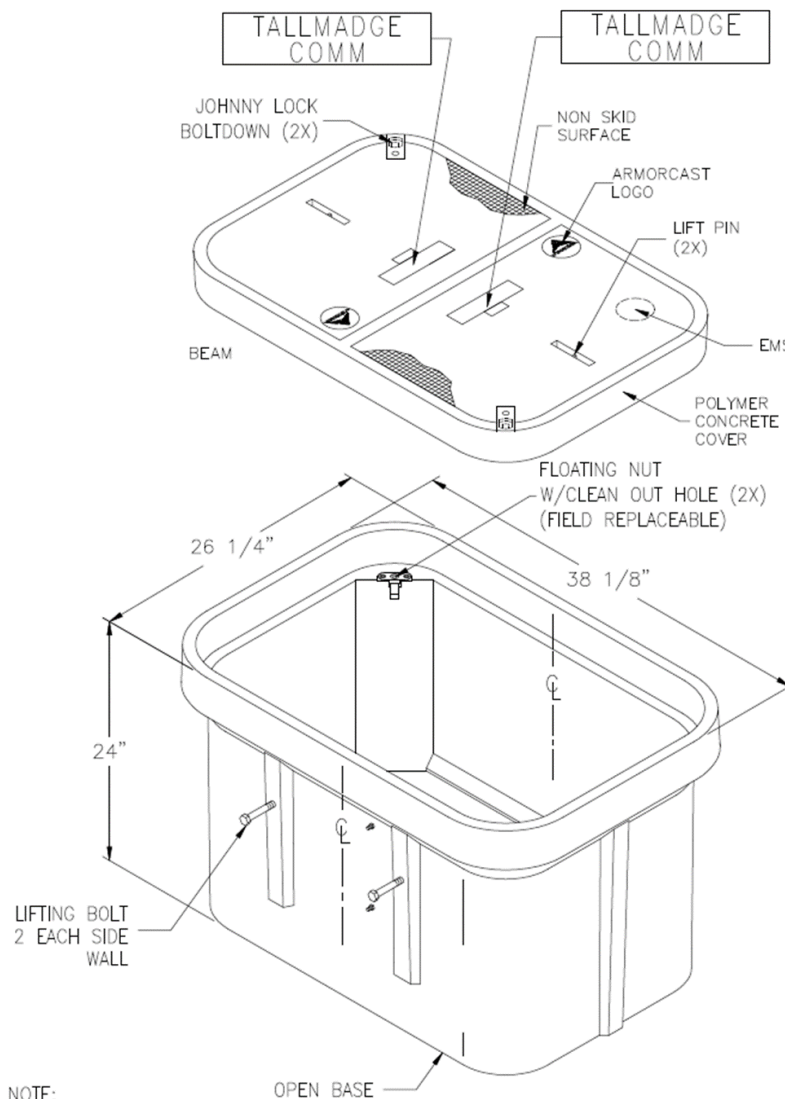

24" X 36" X 24" POLYMER CONCRETE BOX ASSEMBLY

2. RESTORATION:

Restore all disturbed areas to their original or better condition.

All disturbed earth shall be replaced, and any soil stockpiles shall be stabilized with temporary vegetation.

3. PAYMENT:

Basis of payment shall include all materials and labor necessary to complete the work described in this contract including any incidental items such as maintenance of traffic and mobilization.

SECTION IV: PROPOSAL AND SIGNATURE PAGE

FIBER CONDUIT INSTALLATION PHASE 5 TALLMADGE RESERVE

Spec. Item	ITEM No.	DESCRIPTION	ESTIMATED QUANTITY		UNIT PRICE (in figures)			TOTAL AMOUNT BID (total unit price x est. quantity)
					MATERIAL	LABOR	TOTAL	
H	641	INSTALL (2) 1.25" CONDUITS	5,374	LF				
I	641	INSTALL VAULTS W/ LIDS	25	Ea.				

TOTAL BID PROPOSAL: \$ _____

Name of Business _____ Authorized Signature _____

Date _____

Section V: TALLMADGE CODIFIED ORDINANCE

Ordinance 2022-40

Presented by:
Mayor David G. Kline

AUTHORIZING THE DIRECTOR OF PUBLIC SERVICE TO ADVERTISE FOR BIDS AND THE MAYOR TO ENTER INTO CONTRACT FOR CONDUIT INSTALLATION TO PHASES 5 AND 6 OF THE TALLMADGE RESERVE FOR FUTURE FIBER OPTIC SERVICE AND PROVIDING FOR IMMEDIATE ENACTMENT

WHEREAS, Council deems it to be in the best interest of the City to install Conduit to Phases 5 and 6 of the Tallmadge Reserve for future Fiber Optic services.

WHEREAS, the funds were not appropriated in the 2022 Annual Appropriations and will need to be appropriated following the receipt of bids.

NOW, THEREFORE, BE IT ORDAINED BY THE COUNCIL OF THE CITY OF TALLMADGE, COUNTIES OF SUMMIT AND PORTAGE, STATE OF OHIO:

SECTION 1. That the Mayor, acting through the Director of Public Service, is hereby authorized to advertise for bids and to contract with the lowest and best bidder upon proper approval by the Board of Control; for Conduit Installation to Phases 5 and 6 of the Tallmadge Reserve for future Fiber Optic Services with plans and specification now on file in the office of the Director of Public Service, which specification and herby specifically approved.

SECTION 2. That such written contract shall be awarded under the provisions of Tallmadge Codified Ordinance Chapter 143, and shall be approved as to form and correctness by the Director of Law and proper certification of funds by the Director of Finance.

SECTION 3. That it is found and determined that all formal actions of this Council concerning and relating to the adoption of this ordinance were adopted in an open meeting of this Council, and that all deliberations of this Council and of any of its committees on or after November 28, 1975 that resulted in such formal action, were in meetings open to the public, in compliance with all legal requirements including Section 121.22 of the Ohio Revised Code.

SECTION 4. That this ordinance is necessary to provide for and to accomplish the purposes herein set forth, which are conducive to the health, safety, and welfare of the citizens of Tallmadge. For that reason, provided this ordinance shall receive the affirmative vote of three-fourths of the members of Council and approval by the Mayor, it shall be enacted immediately and shall be of immediate effect.

Passed: 3-24-22

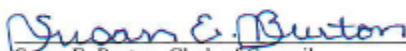
Susan E. Burton, Clerk of Council
MER
3/21/22
Filed with the Mayor 3-24-22

Dennis K. Loughry, President of Council

Approved:

David G. Kline, Mayor

This 24th day of March, 2022

Committee Assignment: Finance

Readings: 1st 3-24-22 2d _____ 3d _____

For: 7 Against: 0 Abstain: 0

Note:

Section VII: BIDDER REFERENCES

Complete the following information: List of 10 or more conduit and fiber installation clients over a 5-year period. Provide a contact and phone number, installation address and date, and size of project. Municipalities and clients, which have been serviced by the contractor for similar work, within a 50 miles radius of the City of Tallmadge.

Municipality	Address	Contact:	Phone Number

NON-MUNICIPALTY REFERENCES / and CONTACTS

Company Name	Address	Contact:	Phone Number

Section VIII: EXPERIENCE of MANAGEMENT/ SUPERVISORY PERSONNEL

The contractor must employ individuals certified and trained to install conduit and fiber installation systems.

Employees Name	Years with Company	Years Managed	Number of Employees Managed