



**CONTRACT DOCUMENTS AND
SPECIFICATIONS
FOR**

TRANS-FLORIDA RAILWAY TRAIL FROM FELLSMERE TO WEST OF I-95

BID NO. 2024006

PROJECT NO. IRC-2115

FM NO. 446073-1-58-01

PREPARED FOR
THE BOARD OF COUNTY COMMISSIONERS
INDIAN RIVER COUNTY, FLORIDA

JOSEPH EARMAN, CHAIRMAN
SUSAN ADAMS, VICE CHAIRMAN
COMMISSIONER JOSEPH E. FLESCHER
COMMISSIONER DERYL LOAR
COMMISSIONER LAURA MOSS

JOHN A. TITKANICH, JR., COUNTY ADMINISTRATOR
RYAN L. BUTLER, CLERK OF COURT AND COMPTROLLER
WILLIAM K. DEBRAAL, COUNTY ATTORNEY
RICHARD B. SZPYRKA, P.E., PUBLIC WORKS DIRECTOR

TABLE OF CONTENTS

Section No. Title

DIVISION 0 - BIDDING DOCUMENTS, CONTRACT FORMS, AND CONDITIONS OF THE CONTRACT

00001	Cover Sheet
00010	Table of Contents

BIDDING DOCUMENTS

00100	Advertisement for Bids
00200	Instructions to Bidders
00300	Bid Package Contents
00310	Bid Form & Itemized Bid Schedule
00430	Bid Bond
00452	Sworn Statement under Section 105.08, Indian River County Code, on Disclosure of Relationships
00454	Sworn Statement under the Florida Trench Safety Act
00456	Qualifications Questionnaire
00458	List of Subcontractors
00460	Certification Regarding Prohibition Against Contracting with Scrutinized Companies
00470	DBE Forms
00472	Non-Collusion Affidavit
00474	Certification for Disclosure of Lobbying Activities on Federal Aid Projects
00476	Certification Regarding Debarment, Suspension, Ineligibility And Voluntary Exclusion- Lower Tier Covered Transactions For Federal Aid Contracts
00490	Certification of Non-Segregation & Non-Discrimination
00492	Build America Buy America Certificate of Compliance
00494	Drug Free Workplace Certification
00496	LAP Certification of Capacity / Status of Contracts on Hand
00500	Certification of Sublet Work

CONTRACT FORMS

00510	Notice of Award
00520	Agreement
00550	Notice to Proceed
00610	Public Construction Bond
00620	Sample Certificate of Liability Insurance
00622	Contractor's Application for Payment
00630	Certificate of Substantial Completion
00632	Contractor's Final Certification of the Work
00634	Professional Surveyor and Mapper's Certification as to the Elevations and Locations of the Work

CONDITIONS OF THE CONTRACT

00700 EJCDC Standard General Conditions of the Construction Contract
00800 Supplementary Conditions to the General Conditions
00942 Change Order Form
00948 Work Change Directive

DIVISION 1 **GENERAL REQUIREMENTS**

DIVISION 2 **TECHNICAL PROVISIONS**

APPENDIX A **PERMITS**

APPENDIX B **IRC FERTILIZER ORDINANCES**

APPENDIX C **INDIAN RIVER COUNTY TRAFFIC ENGINEERING DIVISION
SPECIAL CONDITIONS FOR RIGHT-OF-WAY CONSTRUCTION**

APPENDIX D **REQUIRED CONTRACT PROVISIONS
FEDERAL-AID CONSTRUCTION CONTRACTS**

APPENDIX E **GENERAL WAGE DECISION NUMBER: FL2023017 1/6/2023**

APPENDIX F **VENDOR ELIGIBILITY CHECK PRIOR TO CONTRACT AWARD**

+ + END OF TABLE OF CONTENTS + +

SECTION – 00100 Advertisement for Bids

BOARD OF COUNTY COMMISSIONERS

1801 27th Street
Vero Beach, Florida 32960



**ADVERTISEMENT FOR BIDS
INDIAN RIVER COUNTY**

Sealed bids will be received by Indian River County until **2:00 P.M. on Wednesday, September 20, 2023.** Each bid shall be submitted in a sealed envelope and shall bear the name and address of the bidder on the outside and the words **“TRANS-FLORIDA RAILWAY TRAIL FROM FELLSMERE TO WEST OF I-95“ and Bid No. 2024006.** Bids should be addressed to Purchasing Division, Room B1-301, 1800 27th Street, Vero Beach, Florida 32960. All bids will be opened publicly and read aloud at 2:00 P.M. All bids received after 2:00 P.M., on the day specified above, will not be accepted or considered.

**INDIAN RIVER COUNTY PROJECT NO. IRC-2115
INDIAN RIVER COUNTY BID NO. 2024006**

PROJECT DESCRIPTION: *The proposed project includes the construction of a 12-foot Trail consisting of a coquina base and an asphalt surface. The project further includes some drainage improvements, trail signage and sod.*

All material and equipment furnished and all work performed shall be in strict accordance with the plans, specifications, and contract documents pertaining thereto. Detailed specifications are available at: www.demandstar.com or at www.ircgov.com/departments/budget/purchasing under “Current Solicitations”.

All bidders shall submit one (1) original and one (1) copy of the Bid Proposal forms provided within the specifications. Please note that the questionnaire must be filled out completely including the financial statement. BID SECURITY must accompany each Bid, and must be in the form of an AIA Document A310 Bid Bond, properly executed by the Bidder and by a qualified surety, or a certified check or a cashier’s check, drawn on any bank authorized to do business in the State of Florida. Bid Security must be in the sum of not less than **Five Percent (5%)** of the total amount of the bid, made payable to Indian River County Board of County Commissioners. In the event the Contract is awarded to the Bidder, Bidder will enter in a Contract with the County and furnish the required 100% Public Construction Bond and certificates of insurance within the timeframe set by the County. If Bidder fails to do so, the Bid Security shall be retained by the County as liquidated damages and not as penalty.

Bidders must submit evidence of active registration, or registration submitted entity status in the SAM.gov database.

The County reserves the right to delay awarding of the Contract for a period of **ninety (90)** days after the bid opening, to waive informalities in any bid, or reject any or all bids in whole or in part with or without cause/or to accept the bid that, in its judgement, will serve the best interest of Indian River County, Florida. The County will not reimburse any Bidder for bid preparation costs.

A Pre-Bid Conference will be held on **Wednesday, September 13, 2023 at 10:00 A.M.**, in the first-floor (Public Works) conference room of the Indian River County Administration Building located at 1801 27th Street, Vero Beach, Florida, 32960. **ATTENDANCE AT THIS CONFERENCE IS HIGHLY ENCOURAGED.**

INDIAN RIVER COUNTY

By: Jennifer Hyde
Purchasing Manager

For Publication in the Indian River Press Journal

Date: **08/20/2023**

THIS PROJECT SHALL BE ADVERTISED REGIONALLY FOR A MINIMUM OF 21 DAYS.

For: Indian River Press Journal

Please furnish tear sheet and Affidavit of Publication to:

INDIAN RIVER COUNTY
PURCHASING DIVISION
1800 27th Street
Building "B"
Vero Beach, FL 32960

*** * END OF SECTION * ***

SECTION 00200 – Instructions to Bidders

TABLE OF CONTENTS

<u>Article No. - Title</u>	<u>Page</u>
ARTICLE 1 - DEFINED TERMS	1
ARTICLE 2 - COPIES OF BIDDING DOCUMENTS	1
ARTICLE 3 - QUALIFICATIONS OF BIDDERS.....	1
ARTICLE 4 - EXAMINATION OF BIDDING DOCUMENTS, OTHER RELATED DATA, AND SITE.....	3
ARTICLE 5 - PRE-BID CONFERENCE.....	5
ARTICLE 6 - SITE AND OTHER AREAS	5
ARTICLE 7 - INTERPRETATIONS AND ADDENDA.....	5
ARTICLE 8 - BID SECURITY	6
ARTICLE 9 - CONTRACT TIMES.....	6
ARTICLE 10 - LIQUIDATED DAMAGES.....	6
ARTICLE 11 - SUBSTITUTE AND “OR-EQUAL” ITEMS.....	7
ARTICLE 12 - SUBCONTRACTORS, SUPPLIERS, AND OTHERS	7
ARTICLE 13 - PREPARATION OF BID	7
ARTICLE 14 - BASIS OF BID; EVALUATION OF BIDS	9
ARTICLE 15 - SUBMITTAL OF BID.....	9
ARTICLE 16 - MODIFICATION AND WITHDRAWAL OF BID.....	10
ARTICLE 17 - OPENING OF BIDS	10
ARTICLE 18 - BIDS TO REMAIN SUBJECT TO ACCEPTANCE	11
ARTICLE 19 - AWARD OF CONTRACT.....	11
ARTICLE 20 - CONTRACT SECURITY AND INSURANCE	12
ARTICLE 21 - SIGNING OF AGREEMENT	13

SECTION 00200 – Instructions to Bidders

TABLE OF ARTICLES (Alphabetical by Subject)

Subject	Article
AWARD OF CONTRACT	19
BASIS OF BID; EVALUATION OF BIDS	14
BID SECURITY	8
BIDS TO REMAIN SUBJECT TO ACCEPTANCE	18
CONTRACT SECURITY AND INSURANCE	20
CONTRACT TIMES	9
COPIES OF BIDDING DOCUMENTS	2
DEFINED TERMS	1
EXAMINATION OF BIDDING DOCUMENTS, OTHER RELATED DATA, AND SITE	4
INTERPRETATIONS AND ADDENDA	7
LIQUIDATED DAMAGES	10
MODIFICATION AND WITHDRAWAL OF BID	16
OPENING OF BIDS	17
PRE-BID CONFERENCE	5
PREPARATION OF BID	13
QUALIFICATIONS OF BIDDERS	3
SIGNING OF AGREEMENT	21
SITE AND OTHER AREAS	6
SUBCONTRACTORS, SUPPLIERS, AND OTHERS	12
SUBMITTAL OF BID	15
SUBSTITUTE AND “OR-EQUAL” ITEMS	11

SECTION 00200 – Instructions to Bidders

ARTICLE 1 - DEFINED TERMS

1.01 Terms used in these Instructions to Bidders will have the meanings indicated in the General Conditions and Supplementary Conditions. Additional terms used in these Instructions to Bidders have the meanings indicated below which are applicable to both the singular and plural thereof:

- A. Bidder--The individual or entity who submits a Bid directly to OWNER.
- B. Issuing Office--The office from which the Bidding Documents are to be issued and where the bidding procedures are to be administered.
- C. Successful Bidder--The lowest responsible Bidder submitting a responsive Bid to whom OWNER (on the basis of OWNER's evaluation as hereinafter provided) makes an award.
- D. ENGINEER – References County Engineer or their designee.

ARTICLE 2 - COPIES OF BIDDING DOCUMENTS

- 2.01 Complete sets of the Bidding Documents in the number and for the deposit sum, if any, stated in the Advertisement for Bids or Invitation to Bid may be obtained from the Issuing Office.
- 2.02 Complete sets of Bidding Documents must be used in preparing Bids; neither OWNER nor ENGINEER assumes any responsibility for errors or misinterpretations resulting from the use of incomplete sets of Bidding Documents.
- 2.03 OWNER and ENGINEER in making copies of Bidding Documents available on the above terms do so only for the purpose of obtaining Bids for the Work and do not confer a license or grant for any other use.

ARTICLE 3 - QUALIFICATIONS OF BIDDERS

- 3.01 To demonstrate Bidder's qualifications to perform the Work, within five days of OWNER's request Bidder shall submit written evidence such as financial data, previous experience, present commitments, and such other data as may be called for below.
 - A. Bidder must have at least five years' experience in the construction of similar projects of this size and larger.
 - B. Bidder must have successfully constructed, as prime CONTRACTOR, at least three projects similar in scope to this project.
 - C. Bidder must have good recommendations from at least three clients similar to the OWNER.
 - D. The Bidder's superintendent and assistants must be qualified and experienced in similar projects in all categories.
 - E. Bidder must be able to provide evidence of authority to conduct business in the jurisdiction in which the project is located.

- 3.02 Each bid must contain evidence of Bidder's qualification to do business in the state where the Project is located or covenant to obtain such qualification prior to award of the contract.
- 3.03 The OWNER reserves the right to reject bids from Bidders that are unable to meet the listed required qualifications.
- 3.04 Bidder must be registered with and use, at their sole expense, the Department of Homeland Security's E-Verify system (www.e-verify.gov) to confirm the employment eligibility of all newly hired employees, as required by Section 448.095, F.S.. Owner, contractor, and subcontractors may not enter into a contract unless each party to the contract registers with and uses the E-Verify system. Contractor must obtain affidavits from all subcontractors and suppliers, as required in Section 448.095(5)(b), F.S., stating the subcontractor or supplier does not employ, contract with, or subcontract with an unauthorized alien.
- 3.05 Bidder must hold a current registration as a General Contractor in the State of Florida.
- 3.06 **Conflict of Interest:** Any entity submitting a bid or proposal or entering into a contract with the County shall disclose any relationship that may exist between the contracting entity and a County Commissioner or a County Employee. The relationship with a County Commissioner or a County Employee that must be disclosed is as follows: *father, mother, son, daughter, brother, sister, uncle, aunt, first cousin, nephew, niece, husband, wife, father-in-law, mother-in-law, daughter-in-law, son-in-law, brother-in-law, sister-in-law, stepfather, stepmother, stepson, stepdaughter, stepbrother, stepsister, half-brother, half-sister, grandparent, or grandchild*. The term "affiliate" includes those officers, directors, executives, partners, shareholders, employees, members, and agents who are active in the management of the entity. The disclosure of relationships shall be a sworn statement made on a County approved form. Failure to submit the form may be cause for rejection of the bid or proposal.
- 3.07 **Public Entity Crimes:** Pursuant to Florida Statutes Section 287.133(2)(a), all Bidders are hereby notified that a person or affiliate who has been placed on the convicted vendor list following a conviction for a public entity crime may not submit a bid, proposal, or reply on a contract to provide any goods or services to a public entity (defined as the State of Florida, any of its departments or agencies, or any political subdivision); may not submit a bid, proposal, or reply on a contract with a public entity for the construction or repair of a public building or public work; may not submit bids, proposals, or replies on leases of real property to a public entity; may not be awarded or perform work as a contractor, supplier, subcontractor, or consultant under a contract with any public entity; and may not transact business with any public entity in excess of the threshold amount provided in Florida Statutes Section 287.017 for CATEGORY TWO [currently \$35,000] for a period of 36 months from the date of being placed on the convicted vendor list. A "public entity crime" means a violation of any state or federal law by a person with respect to and directly related to the transaction of business with any public entity or with an agency or political subdivision of any other state or with the United States, including, but not limited to, any bid, proposal, reply, or contract for goods or services, any lease for real property, or any contract for the construction or repair of a public building or public work, involving antitrust, fraud, theft, bribery, collusion, racketeering, conspiracy, or material misrepresentation.
- 3.08 **Records/Audit:** The Bidder shall maintain books, records and documents pertinent to performance under this Invitation and any resulting Agreement in accordance with generally accepted accounting principles consistently applied. The County and the Florida Office of the Inspector General shall have inspection and audit rights to such records for audit purposes during the term of the contract and for three years following the termination of obligations hereunder. Records which relate to any litigation, appeals or settlements of

claims arising from performance under this work or purchase shall be made available until a final disposition has been made of such litigation, appeals, or claims.

ARTICLE 4 - EXAMINATION OF BIDDING DOCUMENTS, OTHER RELATED DATA, AND SITE

4.01 Subsurface and Physical Conditions

A. The Supplementary Conditions identify:

1. Those reports of explorations and tests of subsurface conditions at or contiguous to the Site that Engineer has used in preparing the Bidding Documents.

2. Those drawings of physical conditions in or relating to existing surface and subsurface structures at or contiguous to the Site (except Underground Facilities) that ENGINEER has used in preparing the Bidding Documents.

B. Copies of reports and drawings referenced in paragraph 4.01.A will be made available by OWNER to any Bidder on request. Those reports and drawings are not part of the Contract Documents, but the “technical data” contained therein upon which Bidder is entitled to rely as provided in paragraph 4.02 of the General Conditions has been identified and established in paragraph 4.02 of the Supplementary Conditions. Bidder is responsible for any interpretation or conclusion Bidder draws from any “technical data” or any other data, interpretations, opinions or information contained in such reports or shown or indicated in such drawings.

4.02 Underground Facilities

A. Information and data shown or indicated in the Bidding Documents with respect to existing Underground Facilities at or contiguous to the Site is based upon information and data furnished to OWNER and ENGINEER by OWNERS of such Underground Facilities, including OWNER, or others.

4.03 Hazardous Environmental Condition

A. The Supplementary Conditions identify those reports and drawings relating to a Hazardous Environmental Condition identified at the Site, if any, that ENGINEER has used in preparing the Bidding Documents.

B. Copies of reports and drawings referenced in paragraph 4.03.A will be made available by OWNER to any Bidder on request. Those reports and drawings are not part of the Contract Documents, but the “technical data” contained therein upon which Bidder is entitled to rely as provided in paragraph 4.06 of the General Conditions. Bidder is responsible for any interpretation or conclusion Bidder draws from any “technical data” or any other data, interpretations, opinions, or information contained in such reports or shown or indicated in such drawings.

4.04 Provisions concerning responsibilities for the adequacy of data furnished to prospective Bidders with respect to subsurface conditions, other physical conditions and Underground Facilities, and possible changes in the Bidding Documents due to differing or unanticipated conditions appear in paragraphs 4.02, 4.03, and 4.04 of the General Conditions. Provisions concerning responsibilities for the adequacy of data furnished to prospective Bidders with respect to a Hazardous Environmental Condition at the Site, if any, and possible changes in the Contract

Documents due to any Hazardous Environmental Condition uncovered or revealed at the Site which was not shown or indicated in the Drawings or Specifications or identified in the Contract Documents to be within the scope of the Work appear in paragraph 4.06 of the General Conditions.

4.05 Upon a request directed to the Purchasing Division (purchasing@ircgov.com or (772) 226-1416), OWNER will provide Bidder access to the Site to conduct such examinations, investigations, explorations, tests, and studies as Bidder deems necessary for submission of a Bid. Bidder shall fill all holes and clean up and restore the Site to its former condition upon completion of such explorations, investigations, tests, and studies.

4.06 "This paragraph has been deleted intentionally"

4.07 It is the responsibility of each Bidder before submitting a Bid to:

A. examine and carefully study the Bidding Documents, including any Addenda and the other related data identified in the Bidding Documents;

B. VISIT THE SITE AND BECOME FAMILIAR WITH AND SATISFY BIDDER AS TO THE GENERAL, LOCAL, AND SITE CONDITIONS THAT MAY AFFECT COST, PROGRESS, AND PERFORMANCE OF THE WORK;

C. become familiar with and satisfy Bidder as to all federal, state, and local Laws and Regulations that may affect cost, progress, or performance of the Work;

D. carefully study all reports of explorations and tests of subsurface conditions at or contiguous to the Site and all drawings of physical conditions in or relating to existing surface or subsurface structures at or contiguous to the Site (except Underground Facilities) which have been identified in the Supplementary Conditions as provided in paragraph 4.02 of the General Conditions, and carefully study all reports and drawings of a Hazardous Environmental Condition, if any, at the Site which have been identified in the Supplementary Conditions as provided in paragraph 4.06 of the General Conditions;

E. obtain and carefully study (or assume responsibility for doing so) all additional or supplementary examinations, investigations, explorations, tests, studies, and data concerning conditions (overhead, surface, subsurface, and Underground Facilities) at or contiguous to the Site which may affect cost, progress, or performance of the Work or which relate to any aspect of the means, methods, techniques, sequences, and procedures of construction to be employed by Bidder, including any specific means, methods, techniques, sequences, and procedures of construction expressly required by the Bidding Documents, and safety precautions and programs incident thereto;

F. agree at the time of submitting its Bid that no further examinations, investigations, explorations, tests, studies, or data are necessary for the determination of its Bid for performance of the Work at the price bid and within the times and in accordance with the other terms and conditions of the Bidding Documents;

G. become aware of the general nature of the work to be performed by OWNER and others at the Site that relates to the Work as indicated in the Bidding Documents;

H. correlate the information known to Bidder, information and observations obtained from visits to the Site, reports and drawings identified in the Bidding Documents, and all additional examinations, investigations, explorations, tests, studies, and data with the Bidding Documents;

I. promptly give ENGINEER written notice of all conflicts, errors, ambiguities, or discrepancies that Bidder discovers in the Bidding Documents and confirm that the written resolution thereof by ENGINEER is acceptable to Bidder; and

J. determine that the Bidding Documents are generally sufficient to indicate and convey understanding of all terms and conditions for the performance of the Work.

4.08 The submission of a Bid will constitute an incontrovertible representation by Bidder that Bidder has complied with every requirement of this Article 4, that without exception the Bid is premised upon performing and furnishing the Work required by the Bidding Documents and applying any specific means, methods, techniques, sequences, and procedures of construction that may be shown or indicated or expressly required by the Bidding Documents, that Bidder has given ENGINEER written notice of all conflicts, errors, ambiguities, and discrepancies that Bidder has discovered in the Bidding Documents and the written resolutions thereof by ENGINEER are acceptable to Bidder, and that the Bidding Documents are generally sufficient to indicate and convey understanding of all terms and conditions for performing and furnishing the Work.

ARTICLE 5 - PRE-BID CONFERENCE

5.01 The date, time, and location for the Pre-Bid conference, is specified in the Advertisement for Bids. Representatives of OWNER and ENGINEER will be present to discuss the Project. Bidders are not required to attend and participate in the conference. ENGINEER will transmit to all prospective Bidders of record such Addenda as ENGINEER considers necessary in response to questions arising at the conference. Oral statements may not be relied upon and will not be binding or legally effective.

ARTICLE 6 - SITE AND OTHER AREAS

6.01 The Site is identified in the Bidding Documents. All additional lands and access thereto required for temporary construction facilities, construction equipment, or storage of materials and equipment to be incorporated in the Work are to be obtained and paid for by CONTRACTOR. Easements for permanent structures or permanent changes in existing facilities are to be obtained and paid for by OWNER unless otherwise provided in the Bidding Documents.

ARTICLE 7 - INTERPRETATIONS AND ADDENDA

7.01 CONE OF SILENCE. Potential bidders and their agents shall not communicate in any way with the Board of County Commissioners, County Administrator or any County staff other than Purchasing personnel in reference or relation to this solicitation. This restriction shall be effective from the time of bid advertisement until the Board of County Commissioners meets to authorize award. Such communication may result in disqualification.

7.02 All questions about the meaning or intent of the Bidding Documents are to be submitted to PURCHASING (purchasing@ircgov.com) in writing. Interpretations or clarifications considered necessary by ENGINEER in response to such questions will be issued by Addenda mailed or delivered to all parties through the Issuing Office as having received the Bidding Documents. Questions received less than ten days prior to the date for opening of Bids may not be answered.

Only questions answered by Addenda will be binding. Oral and other interpretations or clarifications will be without legal effect.

7.03 Addenda may be issued to clarify, correct, or change the Bidding Documents as deemed advisable by OWNER or ENGINEER.

ARTICLE 8 - BID SECURITY

8.01 Each Bid must be accompanied by Bid Security made payable to OWNER in the amount of five percent of the Bidder's maximum base bid price and in the form of a certified check; cashier's check; or an AIA Document A310 Bid Bond issued by a surety meeting the requirements of Paragraph 5.01 of the General Conditions. The Bid Bond shall be executed by such sureties as are named in the current list of "Companies Holding Certificates of Authority as Acceptable Sureties on Federal Bonds and as Acceptable Reinsuring Companies" as published in Circular 570 (amended) by the Financial Management Service, Surety Bond Branch, U.S. Department of the Treasury. The Surety must be authorized to issue surety bonds in Florida. The Bidder shall require the attorney-in-fact who executes any Bond, to affix to each a current certified copy of their Power of Attorney, reflecting such person's authority as Power of Attorney in the State of Florida. Further, at the time of execution of the Contract, the Successful Bidder shall for all Bonds, provide a copy of the Surety's current valid Certificate of Authority issued by the United States Department of the Treasury under 31 United States Code sections 9304-9308. The Surety shall also meet the requirements of paragraphs 5.01 and 5.02 of the General Conditions.

8.02 The Bid security of the Successful Bidder will be retained until such Bidder has executed the Contract Documents, furnished the required contract security and met the other conditions of the Notice of Award, whereupon the Bid security will be returned. If the Successful Bidder fails to execute and deliver the Contract Documents and furnish the required contract security within 15 days after the Notice of Award, OWNER may annul the Notice of Award and the Bid security of that Bidder will be retained by the owner. The Bid Security of other Bidders whom OWNER believes to have a reasonable chance of receiving the award may be retained by OWNER until the earlier of seven days after the Effective Date of the Agreement or 91 days after the Bid opening, whereupon Bid Security furnished by such Bidders will be returned.

8.03 Bid Security of other Bidders whom OWNER believes do not have a reasonable chance of receiving the award will be returned within seven days after the Bid opening.

ARTICLE 9 - CONTRACT TIMES

9.01 The number of calendar days within which, or the dates by which, the Work is to be (a) Substantially Completed and (b) also completed and ready for final payment are set forth in the Agreement.

ARTICLE 10 - LIQUIDATED DAMAGES

10.01 Provisions for liquidated damages, if any, are set forth in the Agreement.

ARTICLE 11 - SUBSTITUTE AND "OR-EQUAL" ITEMS

11.01 The Contract, if awarded, will be on the basis of materials and equipment specified or described in the Bidding Documents without consideration of possible substitute or "or-equal" items. Whenever it is specified or described in the Bidding Documents that a substitute or "or-equal" item of material or equipment may be furnished or used by CONTRACTOR if acceptable to ENGINEER, application for such acceptance will not be considered by ENGINEER until after the Effective Date of the Agreement. The procedure for submission of any such application by CONTRACTOR and consideration by ENGINEER is set forth in the General Conditions and may be supplemented in the General Requirements.

ARTICLE 12 - SUBCONTRACTORS, SUPPLIERS, AND OTHERS

12.01 If the Supplementary Conditions require the identity of certain Subcontractors, Suppliers, individuals, or entities to be submitted to OWNER in advance of a specified date prior to the Effective Date of the Agreement, the apparent Successful Bidder, and any other Bidder so requested, shall within five days after Bid opening, submit to OWNER a list of all such Subcontractors, Suppliers, individuals, or entities proposed for those portions of the Work for which such identification is required. Such list shall be accompanied by an experience statement with pertinent information regarding similar projects and other evidence of qualification for each such Subcontractor, Supplier, individual, or entity if requested by OWNER. If OWNER or ENGINEER, after due investigation, has reasonable objection to any proposed Subcontractor, Supplier, individual, or entity, OWNER may, before the Notice of Award is given, request apparent Successful Bidder to submit a substitute, without an increase in the Bid.

12.02 If apparent Successful Bidder declines to make any such substitution, OWNER may award the Contract to the next lowest Bidder that proposes to use acceptable Subcontractors, Suppliers, individuals, or entities. Declining to make requested substitutions will not constitute grounds for forfeiture of the Bid security of any Bidder. Any Subcontractor, Supplier, individual, or entity so listed and against which OWNER or ENGINEER makes no written objection prior to the giving of the Notice of Award will be deemed acceptable to OWNER and ENGINEER subject to revocation of such acceptance after the Effective Date of the Agreement as provided in paragraph 6.06 of the General Conditions.

12.03 CONTRACTOR shall not be required to employ any Subcontractor, Supplier, individual, or entity against whom CONTRACTOR has reasonable objection.

12.04 CONTRACTOR must incorporate into all subcontracts that they must comply with Florida Statutes s.20.055(5).

12.05 CONTRACTOR shall not purchase equipment for State or Local ownership under a Florida Department of Transportation LAP project.

ARTICLE 13 - PREPARATION OF BID

13.01 The Bid form is included with the Bidding Documents. Only the bid form provided by OWNER is acceptable (Bidders are not to recreate or modify the bid form). ***Bids not submitted on the bid form(s) shall be rejected, as will bids submitted on rewritten, recreated or modified bid forms.***

13.02 All blanks on the Bid form shall be completed by printing in ink or by typewriter and the Bid signed. A Bid price shall be indicated for each section, Bid item, alternative, adjustment unit price item, and unit price item listed therein, or the words "No Bid," "No Change," or "Not Applicable" entered.

13.03 A Bid by a corporation shall be executed in the corporate name by the president or a vice-president or other corporate officer accompanied by evidence of authority to sign. The corporate seal shall be affixed and attested by the secretary or an assistant secretary. The corporate address and state of incorporation shall be shown below the signature.

13.04 A Bid by a partnership shall be executed in the partnership name and signed by a partner (whose title must appear under the signature), accompanied by evidence of authority to sign. The official address of the partnership shall be shown below the signature.

13.05 A Bid by a limited liability company shall be executed in the name of the firm by a member and accompanied by evidence of authority to sign. The state of formation of the firm and the official address of the firm must be shown below the signature.

13.06 A Bid by an individual shall show the Bidder's name and official address.

13.07 A Bid by a joint venture shall be executed by each joint venturor in the manner indicated on the Bid form. The official address of the joint venture must be shown below the signature.

13.08 All names shall be typed or printed in ink below the signatures.

13.09 The Bid shall contain an acknowledgment of receipt of all Addenda, the numbers of which shall be filled in on the Bid form.

13.10 The address and telephone number for communications regarding the Bid shall be shown.

13.11 The Bid shall contain evidence of Bidder's authority and qualification to do business in the state where the Project is located or covenant to obtain such qualification prior to award of the Contract. Bidder's state contractor license number or county registration number for the state or county of the Project, if any, shall also be shown on the Bid form.

13.12 All supporting information requested in the Bid Form must be furnished. Do not leave any questions or requests unanswered.

13.13 In accordance with Florida Statutes Section 218.80, the "Public Bid Disclosure Act", Indian River County as OWNER is obligated to disclose all license, permit, impact, or inspection fees that are payable to Indian River County in connection with the construction of the Work by the accepted bidder. All permit, impact, or inspection fees payable to Indian River County in connection with the work on this County project will be paid by Indian River County, with the exception of re-inspection fees. The Bidder shall not include ANY PERMIT, IMPACT, NOR INSPECTION FEES payable to **Indian River County** in the bid.

13.14 CONTRACTOR shall furnish all labor, materials, equipment and incidentals necessary to perform additional work not covered on the Contract Drawings. The **FORCE ACCOUNT** is intended as a contingency for unforeseen work. Lump sum amount for **FORCE ACCOUNT** work is included in the bid schedule. The value of force account work will be determined in accordance with Article 12 of the General Conditions.

ARTICLE 14 - BASIS OF BID; EVALUATION OF BIDS

14.01 Unit Price

A. Bidders shall submit a Bid on a unit price basis for each item of Work listed in the Bid schedule. Omission of unit prices where required will result in disqualification of the bid.

B. The total of all estimated prices will be determined as the sum of the products of the estimated quantity of each item and the unit price Bid for the item. The final quantities and Contract Price will be determined in accordance with paragraph 11.03 of the General Conditions.

C. Discrepancies between the multiplication of units of Work and unit prices will be resolved in favor of the unit prices. Discrepancies between the indicated sum of any column of figures and the correct sum thereof will be resolved in favor of the correct sum. Discrepancies between words and figures will be resolved in favor of the words.

14.02 The Bid price shall include such amounts as the Bidder deems proper for overhead and profit on account of cash allowances, if any, named in the Contract Documents as provided in paragraph 11.02 of the General Conditions.

14.03 The Bidder's attention is called to the fact that any estimate of quantities of work to be done and materials to be furnished under the Specifications as shown on the Bid Schedule, or elsewhere, is approximate only and not guaranteed. The OWNER does not assume any responsibility that the final quantities shall remain in strict accordance with the estimated quantities, nor shall the Bidder plead misunderstanding or deception because of such estimate of quantities or of the character, location of the work, or other conditions pertaining thereto.

14.04 Per section 287.05701, Florida Statutes, as amended, OWNER may not request documentation of, or consider a Bidder's social, political, or ideological interests when determining if the Bidder is responsible, and may not give preference to a Bidder based on the Bidder's social, political, or ideological interests.

ARTICLE 15 - SUBMITTAL OF BID

15.01 The Bid form is to be completed and submitted with the Bid security and the following data:

- A. Sworn Statement Under Section 105.08, Indian River County Code, on Disclosure of Relationships
- B. Sworn Statement Under the Florida Trench Safety Act
- C. Qualifications Questionnaire
- D. List of Subcontractors
- E. Certification Regarding Prohibition Against Contracting with Scrutinized Companies
- F. DBE Forms
- G. Non-collusion Affidavit

- H. Certification for Disclosure of Lobbying Activities on Federal-Aid Contracts
- I. Certification Regarding Debarment, Suspension, Ineligibility and Voluntary Exclusion — Primary Covered Transactions
- J. Certification of Non Segregation & Non Discrimination
- K. Buy America Certificate of Compliance
- L. Drug free Workplace Certification
- M. LAP Certification of Capacity / Status of Contracts on Hand
- N. Certification of Sublet Work

15.02 A Bid shall be submitted no later than the date and time prescribed and at the place indicated in the advertisement or invitation to Bid and shall be enclosed in an opaque sealed envelope plainly marked with the Project Title and Bid Number (and, if applicable, the designated portion of the Project for which the Bid is submitted), Bid Number, the name and address of Bidder, and shall be accompanied by the Bid security and other required documents. If mail or other delivery system sends a Bid, the sealed envelope containing the Bid shall be enclosed in a separate envelope plainly marked on the outside with the notation "BID ENCLOSED." A mailed Bid shall be addressed to Indian River County, Purchasing Division, 1800 27th Street, Vero Beach, Florida, 32960.

ARTICLE 16 - MODIFICATION AND WITHDRAWAL OF BID

16.01 A Bid may be modified or withdrawn by an appropriate document duly executed in the manner that a Bid must be executed and delivered to the place where Bids are to be submitted prior to the date and time for the opening of Bids.

16.02 If within 48 hours after Bids are opened any Bidder files a duly signed written notice with OWNER and promptly thereafter demonstrates to the reasonable satisfaction of OWNER that there was a material and substantial mistake in the preparation of its Bid, that Bidder may withdraw its Bid, and the Bid security will be returned. Thereafter, if the Work is rebid, that Bidder will be disqualified from further bidding on the Work.

ARTICLE 17 - OPENING OF BIDS

17.01 Bids will be opened at the time and place indicated in the advertisement or invitation to Bid and, unless obviously non-responsive, read aloud publicly. An abstract of the amounts of the base Bids and major alternates, if any, will be made available to Bidders after the opening of Bids.

ARTICLE 18 - BIDS TO REMAIN SUBJECT TO ACCEPTANCE

18.01 All Bids will remain subject to acceptance for the period of time stated in the Bid Form, but OWNER may, in its sole discretion, release any Bid and return the Bid security prior to the end of this period.

ARTICLE 19 - AWARD OF CONTRACT

19.01 OWNER reserves the right to reject any or all Bids, including without limitation, nonconforming, nonresponsive, unbalanced, or conditional Bids. OWNER further reserves the right to reject the Bid of any Bidder whom it finds, after reasonable inquiry and evaluation, to be non-responsible. OWNER may also reject the Bid of any Bidder if OWNER believes that it would not be in the best interest of the Project to make an award to that Bidder. OWNER also reserves the right to waive all technicalities and informalities not involving price, time, or changes in the Work and to negotiate contract terms with the Successful Bidder. The County will not reimburse any Bidder for bid preparation costs. Owner reserves the right to cancel the award of any Contract at any time before the execution of such Contract by all parties without any liability to the Owner. For and in consideration of the Owner considering Bids submitted, the Bidder, by submitting its Bid, expressly waives any claim to damages, of any kind whatsoever, in the event the Owner exercises its right to cancel the award in accordance herewith.

19.02 More than one Bid for the same Work from an individual or entity under the same or different names will not be considered. Reasonable grounds for believing that any Bidder has an interest in more than one Bid for the Work may be cause for disqualification of that Bidder and the rejection of all Bids in which that Bidder has an interest.

19.03 In evaluating Bids, OWNER will consider whether or not the Bids comply with the prescribed requirements, and such alternates, unit prices and other data, as may be requested in the Bid Form or prior to the Notice of Award.

19.04 In evaluating Bidders, OWNER will consider the qualifications of Bidders and may consider the qualifications and experience of Subcontractors, Suppliers, and other individuals or entities proposed for those portions of the Work for which the identity of Subcontractors, Suppliers, and other individuals or entities must be submitted as provided in the Supplementary Conditions.

19.05 OWNER may conduct such investigations as OWNER deems necessary to establish the responsibility, qualifications, and financial ability of Bidders, proposed Subcontractors, Suppliers, individuals, or entities to perform the Work in accordance with the Contract Documents.

19.06 If the Contract is to be awarded, OWNER will award the Contract to the Bidder whose Bid is in the best interests of the Project.

19.07 OWNER has no local ordinance or preferences, as set forth in FS 255.0991 (2) in place, therefore no preference prohibited by that section will be considered in the acceptance, review or award of this bid.

19.08 Bidders are hereby notified of the provisions of Section 287.05701, Florida Statutes, as amended, that the County will not request documentation of or consider a Bidder's social, political, or ideological interests when determining if the Bidder is responsible. Bidders are further notified

that the County's governing body may not give preference to a Bidder based on the Bidder's social, political, or Ideological interests.

19.09 Any actual or prospective bidder or proposer who is aggrieved in connection with the bidding and/or selection process may protest to the OWNER's Purchasing Manager. The protest shall be submitted in writing to the Purchasing Manager within seven (7) calendar days after the bidder or proposer knows or should have known of the facts giving rise to the protest.

19.10 The County will reject any bid that is unbalanced, if it is in the best interest of the County to do so. A bid will be considered unbalanced when, in the opinion of the Purchasing Manager, the bid allocates a disproportionate share of costs to the price of one or more bid items in order to reduce the costs to the price of another bid item or items, and if there is a reasonable possibility that the bid will not result in the lowest overall cost to the County.

19.11 CONTRACTOR certifies that it and its related entities as defined by Florida law are not on the Scrutinized Companies that Boycott Israel List, created pursuant to s. 215.4725 of the Florida Statutes, and are not engaged in a boycott of Israel. In addition, if this agreement is for goods or services of one million dollars or more, CONTRACTOR certifies that it and its related entities as defined above by Florida law are not on the Scrutinized Companies with Activities in Sudan List or the Scrutinized Companies with Activities in the Iran Petroleum Energy Sector List, created pursuant to Section 215.473 of the Florida Statutes and are not engaged in business operations in Cuba or Syria.

19.12 Except in the case of concession agreement, as identified in Section 710.703 of this title, no public agency shall be permitted to bid in competition or to enter into subcontracts with private CONTRACTORS.

OWNER may terminate this Contract if CONTRACTOR is found to have submitted a false certification as provided under section 287.135(5), Florida Statutes, been placed on the Scrutinized Companies with Activities in Sudan List or the Scrutinized Companies with Activities in the Iran Petroleum Energy Sector List, or been engaged in business operations in Cuba or Syria, as defined by section 287.135, Florida Statutes.

OWNER may terminate this Contract if CONTRACTOR, including all wholly owned subsidiaries, majority-owned subsidiaries, and parent companies, that exist for the purpose of making profit, is found to have been placed on the Scrutinized Companies that Boycott Israel List or is engaged in a boycott of Israel as set forth in section 215.4725, Florida Statutes.

Accordingly, firms responding to this solicitation shall return with their response an executed copy of the attached "Certification Regarding Prohibition Against Contracting With Scrutinized Companies." Failure to return this executed form with submitted bid/proposal/statement of qualifications will result in the response being deemed non-responsive and eliminated from consideration.

ARTICLE 20 - CONTRACT SECURITY AND INSURANCE

20.01 Article 5 of the General Conditions, as may be modified by the Supplementary Conditions, sets forth OWNER's requirements as to Public Construction Bond and insurance. When the Successful Bidder delivers the executed Agreement to OWNER, it must be accompanied by the required insurance certificate(s) and Bond, unless the Bond has been waived due to the total contract being less than \$100,000.

ARTICLE 21 - SIGNING OF AGREEMENT

21.01 When OWNER gives a Notice of Award to the Successful Bidder, it shall be accompanied by the required number of unsigned counterparts of the Agreement with the other Contract Documents which are identified in the Agreement as attached thereto. Within fifteen (15) days thereafter, Successful Bidder shall sign and deliver the required number of counterparts of the Agreement and attached documents to OWNER.

21.02 OWNER shall return one fully signed counterpart to Successful Bidder.

21.03 Should Bidder to whom the Contract has been awarded refuse or fail to complete the requirements of Article 21.01 above, the additional time in calendar days, required to correctly complete the documents will be deducted, in equal amount, from the Contract time. Or, the OWNER may elect to revoke the Award and the OWNER shall hold the Bid Bond for consequential damages incurred, and the Contract may be awarded as the OWNER desires.

*** * END OF SECTION * ***

SECTION 00300 – Bid Package Contents**THIS PACKAGE CONTAINS:**

<u>SECTION TITLE</u>	<u>SECTION NUMBER</u>
Bid Form	00310
Bid Bond	00430
Sworn Statement on Disclosure of Relationships	00452
Sworn Statement Under the Florida Trench Safety Act	00454
Qualifications Questionnaire	00456
List of Subcontractors	00458
Certification Regarding Prohibition Against Contracting with Scrutinized Companies	00460
DBE Forms	00470
Non-Collusion Affidavit	00472
Certification for Disclosure of Lobbying Activities on Federal-Aid Contracts	00474
Certification Regarding Debarment, Suspension, Ineligibility and Voluntary Exclusion—Primary Covered Transactions	00476
Certification of Non Segregation & Non Discrimination	00490
Buy America Certificate of Compliance	00492
Drug Free Workplace Certification	00494
LAP Certification of Capacity / Status of Contracts on Hand	00496
Certification of Sublet Work	00500

SUBMIT ONE (1) ORIGINAL AND ONE (1) COPY OF THIS COMPLETE PACKAGE WITH YOUR BID

*** * END OF SECTION * ***

SECTION 00310 – Bid Form

PROJECT IDENTIFICATION:

Project Name: **TRANS-FLORIDA RAILWAY TRAIL FROM
FELLSMERE TO WEST OF I-95**

County Project Number: **IRC-2115**

Bid Number: **2024006**

Project Address: **11090 Co Rd 512
Fellsmere, FL 32948**

Project Description: ***The proposed project includes the construction of a 12-foot Trail consisting of a coquina base and an asphalt surface. The project further includes some drainage improvements, trail signage and sod.***

THIS BID IS SUBMITTED TO: INDIAN RIVER COUNTY
1800 27th Street
VERO BEACH, FLORIDA 32960

1.01 The undersigned Bidder proposes and agrees, if this Bid is accepted, to enter into an Agreement with OWNER in the form included in the Bidding Documents to perform all Work as specified or indicated in the Bidding Documents for the prices and within the times indicated in this Bid and in accordance with the other terms and conditions of the Bidding Documents.

2.01 Bidder accepts all of the terms and conditions of the Advertisement or Invitation to Bid and Instructions to Bidders, including without limitation those dealing with the disposition of Bid security. The Bid will remain subject to acceptance for 90 days after the Bid opening, or for such longer period of time that Bidder may agree to in writing upon request of OWNER.

3.01 In submitting this Bid, Bidder represents, as set forth in the Agreement, that:

A. Bidder has examined and carefully studied the Bidding Documents, the other related data identified in the Bidding Documents, and the following Addenda, receipt of all which is hereby acknowledged.

<u>Addendum Date</u>	<u>Addendum Number</u>
_____	_____
_____	_____
_____	_____

B. Bidder has visited the Site and become familiar with and is satisfied as to the general, local and Site conditions that may affect cost, progress, and performance of the Work.

C. Bidder is familiar with and is satisfied as to all federal, state and local Laws and Regulations that may affect cost, progress and performance of the Work.

D. Bidder has carefully studied all: (1) reports of explorations and tests of subsurface conditions at or contiguous to the Site and all drawings of physical conditions in or relating to existing surface or subsurface structures at or contiguous to the Site (except Underground Facilities) which have been identified in the Supplementary Conditions as provided in paragraph 4.02 of the General Conditions, and (2) reports and drawings of a Hazardous Environmental Condition,

if any, which have been identified in the Supplementary Conditions as provided in paragraph 4.06 of the General Conditions.

E. Bidder has obtained and carefully studied (or assumes responsibility for having done so) all additional or supplementary examinations, investigations, explorations, tests, studies and data concerning conditions (surface, subsurface and Underground Facilities) at or contiguous to the Site which may affect cost, progress, or performance of the Work or which relate to any aspect of the means, methods, techniques, sequences, and procedures of construction to be employed by Bidder, including applying the specific means, methods, techniques, sequences, and procedures of construction expressly required by the Bidding Documents to be employed by Bidder, and safety precautions and programs incident thereto.

F. Bidder does not consider that any further examinations, investigations, explorations, tests, studies, or data are necessary for the determination of this Bid for performance of the Work at the price(s) bid and within the times and in accordance with the other terms and conditions of the Bidding Documents.

G. Bidder is aware of the general nature of work to be performed by OWNER and others at the Site that relates to the Work as indicated in the Bidding Documents.

H. Bidder has correlated the information known to Bidder, information and observations obtained from visits to the Site, reports and drawings identified in the Bidding Documents, and all additional examinations, investigations, explorations, tests, studies, and data with the Bidding Documents.

I. Bidder has given ENGINEER written notice of all conflicts, errors, ambiguities, or discrepancies that Bidder has discovered in the Bidding Documents, and the written resolution thereof by ENGINEER is acceptable to Bidder.

J. The Bidding Documents are generally sufficient to indicate and convey understanding of all terms and conditions for the performance of the Work for which this Bid is submitted.

4.01 Bidder further represents that this Bid is genuine and not made in the interest of or on behalf of any undisclosed individual or entity and is not submitted in conformity with any agreement or rules of any group, association, organization or corporation; Bidder has not directly or indirectly induced or solicited any other Bidder to submit a false or sham Bid; Bidder has not solicited or induced any individual or entity to refrain from bidding; and Bidder has not sought by collusion to obtain for itself any advantage over any other Bidder or over OWNER.

[The remainder of page intentionally left blank]

ITEMIZED BID SCHEDULE

IRC-2115

PROJECT NAME: Trans-Florida Railway Trail

PROJECT NO. IRC-2115

BID NO. 2024006

FM NO. 446073-1-58-01

BIDDER'S Name:

Item No.	Description	Unit	Quantity	Unit Price	Amount
101-1	MOBILIZATION	LS	1		
102-1	MAINTENANCE OF TRAFFIC	LS	1		
104-1	ARTIFICIAL COVERINGS/EROSION CONTROL ABATEMENT PRODUCTS	SY	8,150		
104-10-3	SEDIMENT BARRIER	LF	14,800		
104-15	SOIL TRACKING PREVENTION DEVICE	EA	2		
110-1-1	CLEARING & GRUBBING	AC	4.5		
120-1	REGULAR EXCAVATION	CY	2,725		
120-6	EMBANKMENT	CY	100		
160-4	TYPE B STABILIZATION 12" (LBR-40)	SY	13,100		
285-704	OPTIONAL BASE GROUP 4 (6" CEMENTED COQUINA) (LBR 100)	SY	10,500		
285-706	OPTIONAL BASE BROUP 6 (8" CEMENTED COQUINA) (LBR 100) (FPL EASEMENT AREA)	SY	202		
285-711	OPTIONAL BASE GROUP 11 (12" CEMENTED COQUINA) (LBR 100) (FPL EASEMENT AREA)	SY	43		
334-1-12	SUPERPAVE ASPHALT CONCRETE, TRAFFIC B (TYPE SP-9.5, 1.5")	TN	790		
334-1-13	SUPERPAVE ASPHALT CONCRETE TRAFFIC C (TYPE SP-9.5, 1") (FPL EASEMENT)	TN	24		
334-1-13A	SUPERPAVE ASPHALT CONCRETE TRAFFIC C (TYPE SP-12.5, 1") (FPL EASEMENT)	TN	34		
430-175-115	PIPE CULVERT, OPTIONAL MATERIAL, ROUND 15" S/CD (RCP)	LF	24		
430-175-124	PIPE CULVERT, OPTIONAL MATERIAL, ROUND 24" S/CD (RCP)	LF	80		
430-175-224	PIPE CULVERT, OPTIONAL MATERIAL, ROUND 19"X30" S/CD (ERCP)	LF	40		
570-1-2	PERFORMANCE TURF, SOD (MATCH EXISTING)	SY	6,450		
700-1-11	SCRUB JAY SIGNAGE (INSTALLATION ONLY)	AS	2		
700-1-11A	SINGLE POST SIGN, UP TO 12 SF	AS	1		
519-78	BOLLARDS (COLLAPSIBLE)	EA	4		
999-1	ASBUILT SURVEYING AND RECORD DRAWING PREPARATION (BY REGISTERED SURVEYOR)	LS	1		
				SUB-TOTAL =	
999-25A				FORCE ACCOUNT =	\$100,000.00
				TOTAL PROJECT BID AMOUNT (INCLUDING FORCE ACCOUNTS) =	

LS=Lump Sum AC=Acre EA=Each CY=Cubic Yard SY=Square Yard TN=Ton LF=Linear Foot AS=Assembly

NOTE: IF THERE IS A DISCREPANCY BETWEEN THE PLANS (SUMMARY OF PAY ITEMS) AND THE ITEMIZED BID SCHEDULE, THE BID SCHEDULE WILL BE UTILIZED FOR BIDDING PURPOSES.

TOTAL PROJECT BID AMOUNT IN WORDS

5.01 Bidder shall complete the Work in accordance with the Contract Documents for the price(s) contained in the Bid Schedule:

- A. The Discrepancies between the multiplication of units of Work and unit prices will be resolved in favor of the unit prices. Discrepancies between the indicated sum of any column of figures and the correct sum thereof will be resolved in favor of the correct sum. Discrepancies between words and figures will be resolved in favor of the words.
- B. The Owner reserves the right to omit or add to the construction of any portion or portions of the work heretofore enumerated or shown on the plans. Furthermore, the Owner reserves the right to omit in its entirety any one or more items of the Contract without forfeiture of Contract or claims for loss of anticipated profits or any claims by the Contractor on account of such omissions.
- C. Bidder acknowledges that estimated quantities are not guaranteed, and are solely for the purpose of comparison of Bids, and final payment for all Unit Price Bid items will be based on actual quantities provided. The quantities actually required to complete the contract and work may be less or more than so estimated, and, if so, no action for damages or for loss of profits shall accrue to the Contractor by reason thereof.
- D. Unit Prices have been computed in accordance with paragraph 11.03.B of the General Conditions.

6.01 Bidder agrees that the Work will be substantially completed and ready for final payment in accordance with paragraph 14.07.B of the General Conditions on or before the dates or within the number of calendar days indicated in the Agreement.

6.02 Bidder accepts the provisions of the Agreement as to liquidated damages in the event of failure to complete the Work within the times specified, which shall be stated in the Agreement.

7.01 The following documents are attached to and made a condition of this Bid:

- A. Itemized Bid Schedule
- B. Required Bid security in the form of _____
- C. Sworn Statement Under Section 105.08, Indian River County Code, on Disclosure of Relationships
- D. Sworn Statement Under the Florida Trench Safety Act
- E. Qualifications Questionnaire
- F. List of Subcontractors
- G. Certification Regarding Prohibition Against Contracting with Scrutinized Companies
- H. DBE Forms
- I. Non-collusion Affidavit
- J. Certification for Disclosure of Lobbying Activities on Federal-Aid Contracts

- K. Certification Regarding Debarment, Suspension, Ineligibility and Voluntary Exclusion — Primary Covered Transactions
- L. Certification of Non Segregation & Non Discrimination
- M. Buy America Certificate of Compliance
- N. Drug free Workplace Certification
- O. LAP Certification of Capacity / Status of Contracts on Hand
- P. Certification of Sublet Work

8.01 The terms used in this Bid with initial capital letters have the meanings indicated in the Instructions to Bidders, the General Conditions, and the Supplementary Conditions.

SUBMITTED on _____, 20__.

State Contractor License No. _____

If Bidder is:

An Individual

Name (typed or printed): _____

By: _____ (SEAL)
(Individual's signature)

Doing business as: _____

Business address: _____

Phone No.: _____ FAX No.: _____

Email: _____

A Partnership

Partnership Name: _____ (SEAL)

By: _____
(Signature of general partner -- attach evidence of authority to sign)

Name (typed or printed): _____

Business address: _____

Phone No.: _____ FAX No.: _____

Email: _____

A Corporation

Corporation Name: _____ (SEAL)

State of Incorporation: _____

Type (General Business, Professional, Service, Limited Liability): _____

By: _____
(Signature -- attach evidence of authority to sign)

Name (typed or printed): _____

Title: _____

(CORPORATE SEAL)

Attest _____
(Signature of Corporate Secretary)

Business address: _____

Phone No.: _____ FAX No.: _____

Email: _____

Date of Qualification to do business is _____.

A Joint Venture

Joint Venture Name: _____

(SEAL)

By: _____
(Signature of joint venture partner -- attach evidence of authority to sign)

Name (typed or printed): _____

Title: _____

Business address: _____

Phone No.: _____ FAX No.: _____

Email: _____

Joint Venture Name: _____

(SEAL)

By: _____
(Signature -- attach evidence of authority to sign)

Name (typed or printed): _____

Title: _____

Business address: _____

Phone No.: _____ FAX No.: _____

Email: _____

Phone and FAX Number, and Address for receipt of official communications:

(Each joint venturor must sign. The manner of signing for each individual, partnership, and corporation that is a party to the joint venture should be in the manner indicated above.)

**** END OF SECTION ****

SECTION 00430 – AIA DOCUMENT A310 BID BOND

AIA DOCUMENT A310 BID BOND

The Contractor shall use the document form entitled “AIA Document A310 Bid Bond.”

END OF SECTION

SECTION 00452

SWORN STATEMENT UNDER SECTION 105.08, INDIAN RIVER COUNTY CODE, ON DISCLOSURE OF RELATIONSHIPS

THIS FORM MUST BE SIGNED IN THE PRESENCE OF A NOTARY PUBLIC OR OTHER OFFICER AUTHORIZED TO ADMINISTER OATHS.

1. This sworn statement MUST be submitted with Bid, Proposal or Contract No. 2024006

for TRANS-FLORIDA RAILWAY TRAIL FROM FELLSMERE TO WEST OF I-95

2. This sworn statement is submitted by: _____

(Name of entity submitting Statement)

whose business address is:

3. My name is _____

(Please print name of individual signing)

and my relationship to the entity named above is _____

4. I understand that an "affiliate" as defined in Section 105.08, Indian River County Code, means:

The term "affiliate" includes those officers, directors, executives, partners, shareholders, employees, members, and agents who are active in the management of the entity.

5. I understand that the relationship with a County Commissioner or County employee that must be disclosed as follows:

Father, mother, son, daughter, brother, sister, uncle, aunt, first cousin, nephew, niece, husband, wife, father-in-law, mother-in-law, daughter-in-law, son-in-law, brother-in-law, sister-in-law, stepfather, stepmother, stepson, stepdaughter, stepbrother, stepsister, half brother, half sister, grandparent, or grandchild.

6. Based on information and belief, the statement, which I have marked below, is true in relation to the entity submitting this sworn statement. [Please indicate which statement applies.]

_____ Neither the entity submitting this sworn statement, nor any officers, directors, executives, partners, shareholders, employees, members, or agents who are active in management of the entity, have any relationships as defined in section 105.08, Indian River County Code, with any County Commissioner or County employee.

_____The entity submitting this sworn statement, or one or more of the officers, directors, executives, partners, shareholders, employees, members, or agents, who are active in management of the entity have the following relationships with a County Commissioner or County employee:

Name of Affiliate or entity	Name of County Commissioner or employee	Relationship
_____	_____	_____
_____	_____	_____
_____	_____	_____

(Signature)

(Date)

STATE OF _____

COUNTY OF _____

Sworn to (or affirmed) and subscribed before me by means of physical presence or online notarization, this _____ day of _____, 20____, by _____
(name of person making statement).

(Signature of Notary Public - State of Florida)
(Print, Type, or Stamp Commissioned Name of Notary Public)

who is personally known to me or who has produced
_____ as identification.

**** END OF SECTION ****

SECTION 00454 – SWORN STATEMENT UNDER THE FLORIDA TRENCH SAFETY ACT

THIS FORM MUST BE SIGNED BY THE BIDDER WHO WILL BE RESPONSIBLE FOR THE EXCAVATION WORK ("BIDDER"), OR ITS AUTHORIZED REPRESENTATIVE, IN THE PRESENCE OF A NOTARY PUBLIC AUTHORIZED TO ADMINISTER OATHS.

1. This Sworn Statement is submitted with Project No. IRC-2115 for TRANS-FLORIDA RAILWAY TRAIL FROM FELLSMERE TO WEST OF I-95

2. This Sworn Statement is submitted by _____
(Legal Name of Entity Submitting Sworn Statement), hereinafter "BIDDER". The BIDDER's address is _____
BIDDER's Federal Employer Identification Number (FEIN) is _____.

3. My name is _____ and my relationship to the BIDDER
(Print Name of Individual Signing) is _____
(Position or Title)

I certify, through my signature at the end of this Sworn Statement, that I am an authorized representative of the BIDDER.

4. The Trench Safety Standards that will be in effect during the construction of this Project are contained within the Trench Safety Act, Section 553.60 et.seq. Florida Statutes and refer to the applicable Florida Statute(s) and/or OSHA Regulation(s) and include the "effective date" in the citation(s). Reference to and compliance with the applicable Florida Statute(s) and OSHA Regulation(s) is the complete and sole responsibility of the BIDDER. Such reference will not be checked by OWNER or ENGINEER and they shall have no responsibility to review or check the BIDDER's compliance with the Trench Safety Standards.

5. The BIDDER assures the OWNER that it will comply with the applicable Trench Safety Standards.

6. The BIDDER has allocated and included in its bid the total amount of \$ _____, based on the linear feet of trench to be excavated over five (5) feet deep, for compliance with the applicable Trench Safety Standards, and intends to comply with said standards by instituting the following specific method(s) of compliance on this Project: _____

_____.

The determination of the appropriate method(s) of compliance is the complete and sole responsibility of the BIDDER. Such methods will not be checked by the OWNER or ENGINEER for accuracy, completeness, or any other purpose. The OWNER and ENGINEER shall have no responsibility to review or check the BIDDER's compliance with the Trench Safety Standards.

7. The BIDDER has allocated and included in its bid the total amount of \$ _____ based on the square feet of shoring to be used for compliance with shoring safety requirements and intends to comply with said shoring requirements by instituting the following specific method(s) of compliance on this Project: _____

_____.

The determination of the appropriate method(s) of compliance is the complete and sole responsibility of the BIDDER. Such methods will not be checked by the OWNER or ENGINEER for accuracy, completeness or any other purpose. The OWNER and ENGINEER shall have no responsibility to review or check the BIDDER's compliance with the Trench Safety Standards.

- 8. The BIDDER, in submitting this bid, represents that it has obtained and considered all available geotechnical information, has utilized said geotechnical information and that, based on such information and the BIDDER's own information, the BIDDER has sufficient knowledge of the Project's surface and subsurface site conditions and characteristics to assure BIDDER's compliance with the applicable Trench Safety Standards in designing the trench safety system(s) for the Project.

BIDDER: _____

By: _____

Position or Title: _____

Date: _____

STATE OF _____

COUNTY OF _____

Sworn to (or affirmed) and subscribed before me by means of physical presence or online notarization, this _____ day of _____ 20 _____, by _____

(name of person making statement).

(Signature of Notary Public - State of Florida)
(Print, Type, or Stamp Commissioned Name of Notary Public)

who is personally known to me or who has produced _____ as identification.

**** END OF SECTION ****

SECTION 00456 – QUALIFICATIONS QUESTIONNAIRE

NOTICE: THE OWNER RETAINS THE DISCRETION TO REJECT THE BIDS OF NON-RESPONSIBLE BIDDERS.

Documentation Submitted with Project No: IRC-2115

Project Name: TRANS-FLORIDA RAILWAY TRAIL FROM FELLSMERE TO WEST OF I-95

1. Bidder's Name / Address: _____

2. Bidder's Telephone & FAX Numbers: _____

3. Licensing and Corporate Status:
 - a. Is Contractor License current? _____
 - b. Bidder's Contractor License No: _____
[Attach a copy of Contractor's License to the bid]
 - c. Attach documentation from the State of Florida Division of Corporations that indicates the business entity's status is active and that lists the names and titles of all officers.
4. Number of years the firm has performed business as a Contractor in construction work of the type involved in this contract: _____
5. What is the last project OF THIS NATURE that the firm has completed?

6. Has the firm ever failed to complete work awarded to you? _____

[If your answer is "yes", then attach a separate page to this questionnaire that explains the circumstances and list the project name, Owner, and the Owner's telephone number for each project in which the firm failed to complete the work.]
7. Has the firm ever been assessed liquidated damages? _____

[If your answer is "yes", then attach a separate page to this questionnaire that explains the circumstances and list the project name, Owner, and the Owner's telephone number for each project in which liquidated damages have been assessed.]
8. Has the firm ever been charged by OSHA for violating any OSHA regulations? _____

[If your answer is "yes", then attach a separate page to this questionnaire that explains the circumstances and list the project name, Owner, and the Owner's telephone number for each project in which OSHA violations were alleged.]
9. Has the firm implemented a drug-free workplace program in compliance with Florida Statute 287.087? _____

(In the case of a tie, preference will be given to businesses with drug-free workplace programs)

10. Has the firm ever been charged with noncompliance of any public policy or rules?

[If your answer is “yes”, then attach a separate page to this questionnaire that explains the circumstances and list the project name, Owner, and the Owner’s telephone number for each project.]

11. Attach to this questionnaire, a notarized financial statement and other information that documents the firm’s financial strength and history.

12. Has the firm ever defaulted on any of its projects? _____

[If your answer is “yes”, then attach a separate page to this questionnaire that explains the circumstances and list the project name, Owner, and the Owner’s telephone number for each project in which a default occurred.]

13. Attach a separate page to this questionnaire that summarizes the firm’s current workload and that demonstrates its ability to meet the project schedule.

14. Name of person who inspected the site of the proposed work for the firm:

Name: _____ Date of Inspections: _____

15. Name of on-site Project Foreman: _____

Number of years of experience with similar projects as a Project Foreman: _____

16. Name of Project Manager: _____

Number of years of experience with similar projects as a Project Manager: _____

17. State your total bonding capacity: _____

18. State your bonding capacity per job: _____

19. Please provide name, address, telephone number, and contact person of your bonding company:

[The remainder of this page was left blank intentionally]

19. Complete the following table for SIMILAR projects:

Name of Project	Date Completed	Owner	Contact Person: Name/ Email Address/Phone	Original Contract Amount	Final Contract Amount

SECTION 00458 – LIST OF SUBCONTRACTORS

The Bidder **MUST** list below the name and address of each Subcontractor who will perform work under this Contract in excess of one-half percent of the total bid price, and shall also list the portion of the work which will be done by such Subcontractor. After the opening of Bids, additions, changes or substitutions will not be allowed unless approved by Indian River County after a request for such a change has been submitted in writing by the Contractor, which shall include reasons for such request. Subcontractors must be properly licensed and hold a valid Certificate of Competency.

Documentation Submitted with Project No. IRC-2115 for TRANS-FLORIDA RAILWAY TRAIL FROM FELLSMERE TO WEST OF I-95

	Work to be Performed	Subcontractor's Name/Address	Portion of Work (%)
1.			
2.			
3.			
4.			
5.			
6.			
7.			
8.			
9.			
10.			
11.			
12.			
13.			
14.			

Note: Attach additional sheets if required.

**** END OF SECTION ****

SECTION 00460 - Certification Regarding Prohibition Against Contracting with Scrutinized Companies

I hereby certify that neither the undersigned entity, nor any of its wholly owned subsidiaries, majority-owned subsidiaries, parent companies, or affiliates of such entities or business associations, that exists for the purpose of making profit have been placed on the Scrutinized Companies that Boycott Israel List created pursuant to s. 215.4725 of the Florida Statutes, or are engaged in a boycott of Israel.

In addition, if this solicitation is for a contract for goods or services of one million dollars or more, I hereby certify that neither the undersigned entity, nor any of its wholly owned subsidiaries, majority-owned subsidiaries, parent companies, or affiliates of such entities or business associations, that exists for the purpose of making profit are on the Scrutinized Companies with Activities in Sudan List or the Scrutinized Companies with Activities in the Iran Petroleum Energy Sector List, created pursuant to s. 215.473 of the Florida Statutes, or are engaged in business operations in Cuba or Syria as defined in said statute.

I understand and agree that the County may immediately terminate any contract resulting from this solicitation upon written notice if the undersigned entity (or any of those related entities of respondent as defined above by Florida law) are found to have submitted a false certification or any of the following occur with respect to the company or a related entity: (i) it has been placed on the Scrutinized Companies that Boycott Israel List, or is engaged in a boycott of Israel, or (ii) for any contract for goods or services of one million dollars or more, it has been placed on the Scrutinized Companies with Activities in Sudan List or the Scrutinized Companies with Activities in the Iran Petroleum Energy Sector List, or it is found to have been engaged in business operations in Cuba or Syria.

Name of Respondent: _____

By: _____
(Authorized Signature)

Title: _____

Date: _____

SECTION 00470 – DBE BID PACKAGE INFORMATION

STATE OF FLORIDA DEPARTMENT OF TRANSPORTATION DBE BID PACKAGE INFORMATION

275-030-11
EQUAL OPPORTUNITY OFFICE
09/19

DBE Utilization

The Department began its DBE race neutral program January 1, 2000. **Contract specific goals are not placed on Federal/State contracts;** however, the Department has an overall 10.65% DBE goal it must achieve. In order to assist contractors in determining their DBE commitment level, the Department has reviewed the estimates for this letting.

As you prepare your bid, please monitor potential or anticipated DBE utilization for contracts. When the low bidder executes the contract with the Department, information will be requested of the contractor's DBE participation for the project. While the utilization is not mandatory in order to be awarded the project, continuing utilization of DBE firms on contracts supports the success of Florida's DBE Program, and supports contractors' Equal Employment Opportunity and DBE Affirmative Action Programs.

Any project listed as 0% DBE availability does not mean that a DBE may not be used on that project. A 0% DBE availability may have been established due to any of the following reasons: limited identified subcontracting opportunities, minimal contract days, and/or small contract dollar amount. Contractors are encouraged to identify any opportunities to subcontract to DBE's.

Please contact the Equal Opportunity Office at (850) 414-4747 if you have any questions regarding this information.

DBE Reporting

If you are the prime contractor on a project, enter your DBE participation in the Equal Opportunity Compliance system prior to the pre-construction or pre-work conference for all federal and state funded projects. This **will not** become a mandatory part of the contract. It will assist the Department in tracking and reporting planned or estimated DBE utilization. During the contract, the prime contractor is required to report actual payments to DBE and MBE subcontractors through the web-based Equal Opportunity Compliance (EOC) system.

All DBE payments must be reported whether or not you initially planned to utilize the company. In order for our race neutral DBE Program to be successful, your cooperation is imperative. If you have any questions, please contact EOOHelp@dot.state.fl.us.

Bid Opportunity List

The Federal DBE Program requires States to maintain a database of all firms that are participating or attempting to participate on FDOT-assisted contracts. The list must include all firms that bid on prime contracts or bid or quote subcontracts on FDOT-assisted projects, including both **DBE's and non-DBEs**.

Please complete the Bidders Opportunity List through the Equal Opportunity Compliance system within 3 business days of submission of the bid or proposal for ALL subcontractors or sub-consultants who quoted to you for specific project for this letting. The web address to the Equal Opportunity Compliance system is: <https://www.fdot.gov/equalopportunity/eoc.shtm>.

DBE/AA Plans

Contractors bidding on FDOT contracts are to have an approved DBE Affirmative Action Plan (FDOT Form 275-030-11B) on file with the FDOT Equal Opportunity Office before execution of a contract. DBE/AA Plans must be received with the contractors bid or received by the Equal Opportunity Office prior to the award of the contract.

Plans are approved by the Equal Opportunity Office in accordance with Ch. 14-78, Florida Administrative Code. Plans that do not meet these mandatory requirements may not be approved. Approvals are for a (3) three year period and should be updated at anytime there is a change in the company's DBE Liaison Officer and/or President. Contractors may evidence adoption of the DBE/AA Policy and Plan and/or a change in the designated DBE Liaison officer as follows:

- Print the first page of the document on company stationery ("letterhead") that indicates the company's name, mailing address, phone number, etc.
- Print the company's name in the "___" space; next to "Date" print the month/day/year the policy is being signed; record the signature of the company's Chief Executive Officer, President or Chairperson in the space next to "by" and print the full first and last name and position title of the official signing the policy.
- Print the DBE Liaison's full name, email address, business mailing address and phone number the bottom of email.

E-mail the completed and signed DBE AA Plan to: **eeoforms@dot.state.fl.us**.

The Department will review the policy, update department records and issue a notification of approval or disapproval; a copy of the submitted plan will not be returned to the contractor.

SECTION 00472

STATE OF FLORIDA DEPARTMENT OF TRANSPORTATION
NON-COLLUSION DECLARATION AND
COMPLIANCE WITH 49 CFR § 29

575-060-13
RIGHT OF WAY
05/01
Page 1 of 4

ITEM/SEGMENT NO.: _____

F.A.P. NO.: _____

MANAGING DISTRICT: _____

PARCEL NO.: _____

COUNTY OF: _____

BID LETTING OF: _____

I, _____, hereby declare
that I am

(NAME)

_____ of _____

(TITLE)

(FIRM)

of _____

(CITY AND STATE)

and that I am the person responsible within my firm for the final decision as to the price(s) and amount of
this Bid on this State Project.

I further declare that:

1. The prices(s) and amount of this bid have been arrived at independently, without consultation, communication or agreement, for the purpose of restricting competition with any other contractor, bidder or potential bidder.
2. Neither the price(s) nor the amount of this bid have been disclosed to any other firm or person who is a bidder or potential bidder on this project, and will not be so disclosed prior to the bid opening.
3. No attempt has been made or will be made to solicit, cause or induce any other firm or person to refrain from bidding on this project, or to submit a bid higher than the bid of this firm, or any intentionally high or non-competitive bid or other form of complementary bid.
4. The bid of my firm is made in good faith and not pursuant to any agreement or discussion with, or inducement from, any firm or person to submit a complementary bid.
5. My firm has not offered or entered into a subcontract or agreement regarding the purchase of materials or services from any firm or person, or offered, promised or paid cash or anything of value to any firm or person, whether in connection with this or any other project, in consideration for an agreement or promise by any firm or person to refrain from bidding or to submit a complementary bid on this project.
6. My firm has not accepted or been promised any subcontract or agreement regarding the sale of materials or services to any firm or person, and has not been promised or paid cash or anything of

Section 00472 – Non-Collusion Affidavit - 1

SECTION 00472

STATE OF FLORIDA DEPARTMENT OF TRANSPORTATION
**NON-COLLUSION DECLARATION AND
COMPLIANCE WITH 49 CFR § 29**

575-060-13
RIGHT OF WAY
05/01
Page 2 of 4

value by any firm or person, whether in connection with this or any other project, in consideration for my firm's submitting a complementary bid, or agreeing to do so, on this project.

7. I have made a diligent inquiry of all members, officers, employees, and agents of my firm with responsibilities relating to the preparation, approval or submission of my firm's bid on this project and have been advised by each of them that he or she has not participated in any communication, consultation, discussion, agreement, collusion, act or other conduct inconsistent with any of the statements and representations made in this Declaration.

8. As required by Section 337.165, Florida Statutes, the firm has fully informed the Department of Transportation in writing of all convictions of the firm, its affiliates (as defined in Section 337.165(l)(a), Florida Statutes), and all directors, officers, and employees of the firm and its affiliates for violation of state or federal antitrust laws with respect to a public contract or for violation of any state or federal law involving fraud, bribery, collusion, conspiracy or material misrepresentation with respect to a public contract. This includes disclosure of the names of current employees of the firm or affiliates who were convicted of contract crimes while in the employ of another company.

9. I certify that, except as noted below, neither my firm nor any person associated therewith in the capacity of owner, partner, director, officer, principal, investigator, project director, manager, auditor, and/or position involving the administration of Federal funds:

(a) is presently debarred, suspended, proposed for debarment, declared ineligible, or voluntarily excluded from covered transactions, as defined in 49 CFR §29.110(a), by any Federal department or agency;

(b) has within a three-year period preceding this certification been convicted of or had a civil judgment rendered against him or her for: commission of fraud or a criminal offense in connection with obtaining, attempting to obtain, or performing a Federal, State or local government transaction or public contract; violation of Federal or State antitrust statutes; or commission of embezzlement, theft, forgery, bribery, falsification or destruction of records, making false statements or receiving stolen property;

(c) is presently indicted for or otherwise criminally or civilly charged by a Federal, State or local governmental entity with commission of any of the offenses enumerated in paragraph 9(b) of this certification; and

(d) has within a three-year period preceding this certification had one or more Federal, State or local government public transactions terminated for cause or default.

10. I(We), certify that I(We), shall not knowingly enter into any transaction with any subcontractor, material supplier, or vendor who is debarred, suspended, declared ineligible, or voluntarily excluded from participation in this contract by any Federal Agency unless authorized by the Department.

Where I am unable to declare or certify as to any of the statements contained in the above stated paragraphs numbered (1) through (10), I have provided an explanation in the "Exceptions" portion below or by attached separate sheet.

EXCEPTIONS:

SECTION 00472

STATE OF FLORIDA DEPARTMENT OF TRANSPORTATION
**NON-COLLUSION DECLARATION AND
COMPLIANCE WITH 49 CFR § 29**

575-060-13
RIGHT OF WAY
05/01
Page 3 of 4

(Any exception listed above will not necessarily result in denial of award, but will be considered in determining bidder responsibility. For any exception noted, indicate to whom it applies, initiating agency and dates of agency action. Providing false information may result in criminal prosecution and/or administrative sanctions.)

I declare under penalty of perjury that the foregoing is true and correct.

CONTRACTOR: _____ (Seal)

BY: _____

NAME AND TITLE PRINTED

WITNESS:

BY: _____

SIGNATURE

WITNESS:

Executed on this _____ day of _____, _____

**FAILURE TO FULLY COMPLETE AND EXECUTE THIS DOCUMENT
MAY RESULT IN THE BID BEING DECLARED NONRESPONSIVE**

REQUIRED CONTRACT PROVISIONS

This certification applies to subcontractors, material suppliers, vendors and other lower tier participants.

- Appendix B of 49 CFR Part 29 –

Appendix B—Certification Regarding Debarment, Suspension, Ineligibility and Voluntary Exclusion—
Lower Tier Covered Transactions

Instructions for Certification

1. By signing and submitting this proposal, the prospective lower tier participant is providing the certification set out below.
2. The certification in this clause is a material representation of fact upon which reliance was placed when this transaction was entered. If it is later determined that the prospective lower tier participant knowingly rendered an erroneous certification, in addition to other remedies available to the Federal Government, the department or agency with which this transaction originated may pursue available remedies, including suspension and/or debarment.

SECTION 00472

STATE OF FLORIDA DEPARTMENT OF TRANSPORTATION
**NON-COLLUSION DECLARATION AND
COMPLIANCE WITH 49 CFR § 29**

575-060-13
RIGHT OF WAY
05/01
Page 4 of 4

3. The prospective lower tier participant shall provide immediate written notice to the person to which this proposal is submitted if at any time the prospective lower tier participant learns that its certification was erroneous when submitted or has become erroneous by reason of changed circumstances.

4. The terms "covered transaction," "debarred," "suspended," "ineligible," "lower tier covered transaction," "participant," "person," "primary covered transaction," "principal," "proposal," and "voluntarily excluded," as used in this clause, have the meanings set out in the Definitions and Coverage sections of rules implementing Executive Order 12549. You may contact the person to whom this proposal is submitted for assistance in obtaining a copy of those regulations.

5. The prospective lower tier participant agrees by submitting this proposal that it shall not knowingly enter into any lower tier covered transaction with a person who is debarred, suspended, declared ineligible, or voluntarily excluded from participation in this covered transaction, unless authorized by the department or agency with which this transaction originated.

6. The prospective lower tier participant further agrees by submitting this proposal that it will include this clause titled "Certification Regarding Debarment, Suspension, Ineligibility and Voluntary Exclusion--Lower Tier Covered Transaction," without modification, in all lower tier covered transactions and in all solicitations for lower tier covered transactions.

7. A participant in a covered transaction may rely upon a certification of a prospective participant in a lower tier covered transaction that it is not debarred, suspended, ineligible, or voluntarily excluded from the covered transaction, unless it knows that the certification is erroneous. A participant may decide the method and frequency by which it determines the eligibility of its principals. Each participant may, but is not required to, check the Non-procurement List.

8. Nothing contained in the foregoing shall be construed to require establishment of a system of records in order to render in good faith the certification required by this clause. The knowledge and information of a participant is not required to exceed that which is normally possessed by a prudent person in the ordinary course of business dealings.

9. Except for transactions authorized under paragraph 5 of these instructions, if a participant in a covered transaction knowingly enters into a lower tier covered transaction with a person who is suspended, debarred, ineligible, or voluntarily excluded from participation in this transaction, in addition to other remedies available to the Federal Government, the department or agency with which this transaction originated may pursue available remedies, including suspension and/or debarment.

Certification Regarding Debarment, Suspension, Ineligibility and Voluntary Exclusion—Lower Tier Covered Transactions

(1) The prospective lower tier participant certifies, by submission of this proposal, that neither it nor its principals is presently debarred, suspended, proposed for debarment, declared ineligible, or voluntarily excluded from participation in this transaction by any Federal department or agency.

(2) Where the prospective lower tier participant is unable to certify to any of the statements in this certification, such prospective participant shall attach an explanation to this proposal.

SECTION 00474

STATE OF FLORIDA DEPARTMENT OF TRANSPORTATION

**CERTIFICATION FOR DISCLOSURE OF LOBBYING ACTIVITIES
ON FEDERAL-AID CONTRACTS
(Compliance with 49CFR, Section 20.100 (b))**

375-030-33
PROCUREMENT
10/01

The prospective participant certifies, by signing this certification, that to the best of his or her knowledge and belief:

(1) No federal appropriated funds have been paid or will be paid, by or on behalf of the undersigned, to any person for influencing or attempting to influence an officer or employee of any federal agency, a Member of Congress, an officer or employee of Congress, or an employee of a Member of Congress in connection with the awarding of any federal contract, the making of any federal grant, the making of any federal loan, the entering into of any cooperative agreement, and the extension, continuation, renewal, amendment, or modification of any federal contract, grant, loan, or cooperative agreement.

(2) If any funds other than federal appropriated funds have been paid or will be paid to any person for influencing or attempting to influence an officer or employee of any federal agency, a Member of Congress, an officer or employee of Congress, or an employee of a Member of Congress in connection with this federal contract, grant, loan, or cooperative agreement, the undersigned shall complete and submit Standard Form-LLL, "Disclosure of Lobbying Activities", in accordance with its instructions. (Standard Form-LLL can be obtained from the Florida Department of Transportation's Professional Services Administrator or Procurement Office.)

This certification is a material representation of fact upon which reliance was placed when this transaction was made or entered into. Submission of this certification is a prerequisite for making or entering into this transaction imposed by Section 1352, Title 31, U.S. Code. Any person who fails to file the required certification shall be subject to a civil penalty of not less than \$10,000 and not more than \$100,000 for each such failure.

The prospective participant also agrees by submitting his or her proposal that he or she shall require that the language of this certification be included in all lower tier subcontracts, which exceed \$100,000 and that all such subrecipients shall certify and disclose accordingly.

Name of Consultant: _____

By: _____ Date: _____

Authorized Signature: _____
Title:

STATE OF FLORIDA DEPARTMENT OF TRANSPORTATION
DISCLOSURE OF LOBBYING ACTIVITIES

375-030-34
 PROCUREMENT
 02/16

Is this form applicable to your firm?

If *no*, then please complete section 4 below for "Prime"

1. Type of Federal Action: a. contract b. grant c. cooperative agreement d. loan e. loan guarantee f. loan insurance	2. Status of Federal Action: a. bid/offer/application b. initial award c. post-award	3. Report Type: a. initial filing b. material change For Material Change Only: Year: _____ Quarter: _____ Date of last report: _____ (mm/dd/yyyy)
4. Name and Address of Reporting Entity: <input type="checkbox"/> Prime <input type="checkbox"/> Subawardee Tier _____, <i>if known</i> : _____ _____ _____ Congressional District, <i>if known</i> : 4c _____	5. If Reporting Entity in No. 4 is a Subawardee, Enter Name and Address of Prime: _____ _____ _____ _____ Congressional District, <i>if known</i> : _____	
6. Federal Department/Agency: _____ _____	7. Federal Program Name/Description: _____ _____ CFDA Number, <i>if applicable</i> : _____	
8. Federal Action Number, if known: _____	9. Award Amount, if known: \$ _____	
10. a. Name and Address of Lobbying Registrant <i>(if individual, last name, first name, MI):</i> _____ _____ _____	b. Individuals Performing Services <i>(including address if different from No. 10a)</i> <i>(last name, first name, MI):</i> _____ _____ _____	
11. Information requested through this form is authorized by title 31 U.S.C. section 1352. This disclosure of lobbying activities is a material representation of fact upon which reliance was placed by the tier above when this transaction was made or entered into. This disclosure is required pursuant to 31 U.S.C. 1352. This information will be available for public inspection. Any person who fails to file the required disclosure shall be subject to a civil penalty of not less than \$10,000 and not more than \$100,000 for each such failure.	Signature: _____ Print Name: _____ Title: _____ Telephone No.: _____ Date (mm/dd/yyyy): _____	
Federal Use Only:		Authorized for Local Reproduction Standard Form LLL (Rev. 7-97)

INSTRUCTIONS FOR COMPLETION OF SF-LLL, DISCLOSURE OF LOBBYING ACTIVITIES

This disclosure form shall be completed by the reporting entity, whether subawardee or prime Federal recipient, at the initiation or receipt of a covered Federal action, or a material change to a previous filing, pursuant to title 31 U.S.C. section 1352. The filing of a form is required for each payment or agreement to make payment to any lobbying entity for influencing or attempting to influence an officer or employee of any agency, a Member of Congress, an officer or employee of Congress, or an employee of a Member of Congress in connection with a covered Federal action. Complete all items that apply for both the initial filing and material change report. Refer to the implementing guidance published by the Office of Management and Budget for additional information.

1. Identify the type of covered Federal action for which lobbying activity is and/or has been secured to influence the outcome of a covered Federal action.
2. Identify the status of the covered Federal action.
3. Identify the appropriate classification of this report. If this is a follow up report caused by a material change to the information previously reported, enter the year and quarter in which the change occurred. Enter the date of the last previously submitted report by this reporting entity for this covered Federal action.
4. Enter the full name, address, city, State and zip code of the reporting entity. Include Congressional District, if known. Check the appropriate classification of the reporting entity that designates if it is, or expects to be, a prime or subaward recipient. Identify the tier of the subawardee, e.g., the first subawardee of the prime is the 1st tier. Subawards include but are not limited to subcontracts, subgrants and contract awards under grants.
5. If the organization filing the report in item 4 checks "Subawardee," then enter the full name, address, city, State and zip code of the prime Federal recipient. Include Congressional District, if known.
6. Enter the name of the Federal agency making the award or loan commitment. Include at least one organizational level below agency name, if known. For example, Department of Transportation, United States Coast Guard.
7. Enter the Federal program name or description for the covered Federal action (item 1). If known, enter the full Catalog of Federal Domestic Assistance (CFDA) number for grants, cooperative agreements, loans, and loan commitments.
8. Enter the most appropriate Federal identifying number available for the Federal action identified in item 1 (e.g., Request for Proposal (RFP) number; Invitation for Bid (IFB) number; grant announcement number; the contract, grant, or loan award number; the application/proposal control number assigned by the Federal agency). Include prefixes, e.g., "RFP-DE-90-001."
9. For a covered Federal action where there has been an award or loan commitment by the Federal agency, enter the Federal amount of the award/loan commitment for the prime entity identified in item 4 or 5.
10.
 - (a) Enter the full name, address, city, State and zip code of the lobbying registrant under the Lobbying Disclosure Act of 1995 engaged by the reporting entity identified in item 4 to influence the covered Federal action.
 - (b) Enter the full names of the individual(s) performing services, and include full address if different from 10 (a). Enter Last Name, First Name, and Middle Initial (MI).

STATE OF FLORIDA DEPARTMENT OF TRANSPORTATION
DISCLOSURE OF LOBBYING ACTIVITIES

375-030-34
PROCUREMENT
02/16

11. The certifying official shall sign and date the form, print his/her name, title, and telephone number.

According to the Paperwork Reduction Act, as amended, no persons are required to respond to a collection of information unless it displays a valid OMB Control Number. The valid OMB control number for this information collection is OMB No. 0348-0046. Public reporting burden for this collection of information is estimated to average 10 minutes per response, including time for reviewing instructions, searching existing data sources, gathering and maintaining the data needed, and completing and reviewing the collection of information. Send comments regarding the burden estimate or any other aspect of this collection of information, including suggestions for reducing this burden, to the Office of Management and Budget, Paperwork Reduction Project (0348-0046), Washington, DC 20503.

SECTION 00476

STATE OF FLORIDA DEPARTMENT OF TRANSPORTATION

**CERTIFICATION REGARDING DEBARMENT, SUSPENSION,
INELIGIBILITY AND VOLUNTARY EXCLUSION-
LOWER TIER COVERED TRANSACTIONS FOR FEDERAL AID CONTRACTS**
(Compliance with 2 CFR Parts 180 and 1200)

375-030-32
PROCUREMENT
11/15

It is certified that neither the below identified firm nor its principals are presently suspended, proposed for debarment, declared ineligible, or voluntarily excluded from participation in this transaction by any federal department or agency.

Name of Consultant/Contractor: _____

By: _____

Date: _____

Title: _____

Instructions for Certification

Instructions for Certification - Lower Tier Participants:

(Applicable to all subcontracts, purchase orders and other lower tier transactions requiring prior FHWA approval or estimated to cost \$25,000 or more - 2 CFR Parts 180 and 1200)

- a. By signing and submitting this proposal, the prospective lower tier is providing the certification set out below.
- b. The certification in this clause is a material representation of fact upon which reliance was placed when this transaction was entered into. If it is later determined that the prospective lower tier participant knowingly rendered an erroneous certification, in addition to other remedies available to the Federal Government, the department, or agency with which this transaction originated may pursue available remedies, including suspension and/or debarment.
- c. The prospective lower tier participant shall provide immediate written notice to the person to which this proposal is submitted if at any time the prospective lower tier participant learns that its certification was erroneous by reason of changed circumstances.
- d. The terms "covered transaction," "debarred," "suspended," "ineligible," "participant," "person," "principal," and "voluntarily excluded," as used in this clause, are defined in 2 CFR Parts 180 and 1200. You may contact the person to which this proposal is submitted for assistance in obtaining a copy of those regulations. "First Tier Covered Transactions" refers to any covered transaction between a grantee or subgrantee of Federal funds and a participant (such as the prime or general contract). "Lower Tier Covered Transactions" refers to any covered transaction under a First Tier Covered Transaction (such as subcontracts). "First Tier Participant" refers to the participant who has entered into a covered transaction with a grantee or subgrantee of Federal funds (such as the prime or general contractor). "Lower Tier Participant" refers any participant who has entered into a covered transaction with a First Tier Participant or other Lower Tier Participants (such as subcontractors and suppliers).
- e. The prospective lower tier participant agrees by submitting this proposal that, should the proposed covered transaction be entered into, it shall not knowingly enter into any lower tier covered transaction with a person who is debarred, suspended, declared ineligible, or voluntarily excluded from participation in this covered transaction, unless authorized by the department or agency with which this transaction originated.
- f. The prospective lower tier participant further agrees by submitting this proposal that it will include this clause titled "Certification Regarding Debarment, Suspension, Ineligibility and Voluntary Exclusion-Lower Tier Covered Transaction," without modification, in all lower tier covered transactions and in all solicitations for lower tier covered transactions exceeding the \$25,000 threshold.
- g. A participant in a covered transaction may rely upon a certification of a prospective participant in a lower tier covered transaction that is not debarred, suspended, ineligible, or voluntarily excluded from the covered transaction, unless it knows that the certification is erroneous. A participant is responsible for ensuring that its principals are not suspended, debarred, or otherwise

Section 00476 – Certification Regarding Debarment, Suspension, Ineligibility And Voluntary Exclusion-Lower Tier Covered Transactions For
Federal Aid Contracts - 1

SECTION 00476

STATE OF FLORIDA DEPARTMENT OF TRANSPORTATION
**CERTIFICATION REGARDING DEBARMENT, SUSPENSION,
INELIGIBILITY AND VOLUNTARY EXCLUSION-
LOWER TIER COVERED TRANSACTIONS FOR FEDERAL AID CONTRACTS**
(Compliance with 2 CFR Parts 180 and 1200)

375-030-32
PROCUREMENT
11/15

ineligible to participate in covered transactions. To verify the eligibility of its principals, as well as the eligibility of any lower tier prospective participants, each participant may, but is not required to, check the Excluded Parties List System website (<https://www.epls.gov/>), which is compiled by the General Services Administration.

h. Nothing contained in the foregoing shall be construed to require establishment of a system of records in order to render in good faith the certification required by this clause. The knowledge and information of participant is not required to exceed that which is normally possessed by a prudent person in the ordinary course of business dealings.

i. Except for transactions authorized under paragraph e of these instructions, if a participant in a covered transaction knowingly enters into a lower tier covered transaction with a person who is suspended, debarred, ineligible, or voluntarily excluded from participation in this transaction, in addition to other remedies available to the Federal Government, the department or agency with which this transaction originated may pursue available remedies, including suspension and/or debarment.

SECTION 00490
 STATE OF FLORIDA DEPARTMENT OF TRANSPORTATION
**CERTIFICATION OF NON SEGREGATION &
 NON DISCRIMINATION**

275-030-13
 EQUAL OPPORTUNITY OFFICE
 07/09

SECTION 1: PROJECT IDENTIFICATION				
1. Financial Project No.	2. F.A.P. No.	3. FDOT LAP Contract No.	4. County	5. District or Name of Local Agency
6. Prime Contractor 's Name				
7. Company Name of Contractor, Supplier, Rental Company or Agency Submitting this certification				8. FEID No of Co. in Box 7
SECTION 2: CERTIFICATION STATEMENTS				
CERTIFICATION OF NONSEGREGATED FACILITIES		CERTIFICATION OF NON DISCRIMINATION		
<p>As a federally assisted construction contractor, I hereby certify: the following for t his company:</p> <p>A. This company does not maintain or provide any segregated facilities for employees at any of our establishments and we do not permit our employees to perform their services at any location, under our control, where segregated facilities are maintained.</p> <p>B. Agreement that a breach of this certification is a violation of the equal opportunity clause in this contract.</p> <p>C. We will obtain and retain identical certifications from proposed subcontractors prior to the award of subcontracts exceeding \$10,000 which are not exempt from the provisions of the equal opportunity clause.</p> <p>As used in this certification, the terms "segregated facilities" means any waiting rooms, work areas, restrooms and washrooms, restaurants and fountains, recreation or entertainment area, transportation, and housing facilities provided for employees which are segregated by explicit directives or are in fact segregated on the basis of race, color, religion or national origin because of habit, local custom, or any other reason.</p>		<p>As a contractor, sub recipient or subcontractor on a Federally funded contract, this company certifies that it shall not discriminate on the basis of race, color, national origin, or sex in the performance of such contracts.</p> <p>The contractor shall carry out applicable requirements of 49 CFR Part 26 in the award and administration of DOT assisted contracts. The company agrees that a failure to carry out these requirements is a material breach of contract, which may result in the contract's termination or such other remedy as the recipient deems appropriate.</p> <p>Each subcontract, rental agreement and or material supplier agreement this company subsequently enters into for this contact will require this same Certification.</p> <p>It is the policy of this company to assure that applicants are employed, and that employees are treated during employment, without regard to their race, religion, sex, color, national origin, age or disability. Actions include: employment, upgrading, demotion, or transfer; recruitment or recruitment advertising; layoff or termination; rates of pay and other forms of compensation; and selection for training, including apprenticeship, pre apprenticeship, and/or on-the-job training.</p> <p>This certification extends to the project identified above and affirms our commitment to insure nondiscrimination and to take affirmative action to assure equal opportunity as set forth under laws, executive orders, rules, regulations (28 CFR 35, 29 CFR 1630 and 41 CFR 60) and orders of the Secretary of Labor as modified by the provisions of FHWA-1273.</p> <p>Compliance with Title VI of the Civil Rights Act and the provisions of the American Disabilities Act of 1990 are incorporated in this certification.</p>		
9. Name (first/last) of corporate Official signing Certification		10. Job Title of person named in Box 9		
11. Signature of Certifying Official			12. Date of Signature	

Certification of Non Segregation & Non Discrimination Instructions for Completing Form

This form is provided to contractors on federally assisted road and bridge construction projects to affirm their commitment to nondiscrimination and non segregated facilities during the term of a contract.

Box 1: Fin. Proj No. – The Financial Project Number

Box 2: FAP No. – The Federal Aid Project Number assigned to federally funded projects or 'non-FAP'

Box 3: FDOT LAP Contract No. – The project's Local Area Project ('LAP') number

Box 4: County – County or counties project work is being performed in

Box 5: District or Local Agency – The Department's District Number Designation where the project is located Districts are 1-7, and the Turnpike District or the name of the city, county or entity administering the contract

Box 6: Prime Contractor Name – The name of the prime contractor.

Box 7: Company Name of Contractor, Supplier, Rental Company or Agency Submitting this certification – name of company submitting the certification

Box 8: FEID No. – Federal Identification Number of company named in Box 7

Box 9: Name (first, last (of corporate official signing certification. – First name, last name

Box 10: Job Title of person named in Box 9 – job title

Box 11: Signature of Certifying Official – signature of person named in Box 9

Box 12: Date of signature – Month/day/year of signature

BUILD AMERICA BUY AMERICA CERTIFICATE OF COMPLIANCE

CERTIFICATE OF COMPLIANCE



COMPLIANCE

The bidder hereby certifies that it will Comply with Section 70914 of Public Law No. 117-58, §§ 70901-52, also known as the Infrastructure Investment and Jobs Act (IIJA), Public Law 117-58, which includes the Build America, Buy America Act (BABA). Domestic compliance for all affected products will be listed on the APL. Bidder acknowledges that it will be required to produce BABA certification(s) from the producer(s) of all components prior to incorporating any such materials into the work or project.

Company Name: _____

Authorized By: _____
(Sign) (Print Name)

Title: _____ Date: _____

SECTION 00494

DRUG FREE WORKPLACE CERTIFICATION

The undersigned Bidder, in accordance with Florida Statute 287.087 hereby certifies that

_____ does:
(Name of Business)

1. Publish a statement notifying employees that the unlawful manufacture, distribution, dispensing, possession, or use of a controlled substance is prohibited in the workplace and specifying the actions that will be taken against employees for violation of such prohibition.
2. Inform employees about the dangers of drug abuse in the workplace, the business' policy of maintaining a drug-free workplace, any available drug counseling, rehabilitation, and employee assistance programs, and the penalties that may be imposed upon employees for drug abuse violations.
3. Give each employee engaged in providing the commodities or contractual services that are under this bid a copy of the statement specified in subsection (1).
4. In the statement specified in subsection (1), notify the employees that, as a condition of working on the commodities, or contractual services that are under bid, the employee will abide by the terms of the statement, and will notify the employer of any conviction of, or plea of guilty, or *nolo contendere* to any violation of Chapter 1893, or of any controlled substance law of the United States, or any State, for a violation occurring in the workplace no later than five (5) days after such conviction.
5. Impose a sanction on, or require the satisfactory participation in a drug abuse assistance, or rehabilitation program, if such is available in the employee's community, by any employee who is so convicted.
6. Make a good faith effort to continue to maintain a drug-free workplace through implementation of this section.

As the person authorized to sign the statement, I certify that this firm complies fully with the above requirements.

Bidders Signature

Date

SECTION 00496

STATE OF FLORIDA DEPARTMENT OF TRANSPORTATION
LAP CERTIFICATION OF CURRENT CAPACITY

525-010-46
PROGRAM MANAGEMENT
09/20
Page 2 of 2

CONFIDENTIAL per Ch 337.14(1) F.S.

For bids to be received on _____
(Letting Date)

Fill in your FDOT Vendor Number VF _____ (Only applicable to FDOT pre-qualified contractors)
--

CERTIFICATE

I hereby certify that the amount of any proposal submitted by this bidder for the above letting does not exceed the amount of the Firm's CURRENT CAPACITY (maximum capacity rating less total uncompleted work).

The total uncompleted work as shown on
the "Status of Contracts on Hand" report (page 2) \$ _____

I further certify that the "Status of Contracts on Hand" report (page 2) was prepared as follows:

1. If the letting is before the 25th day of the month, the certificate and report reflect the uncompleted work as of the 15th day of the month, last preceding the month of the letting.
2. If the letting is after the 25th day of the month, the certificate and report reflects the uncompleted work in progress as of the 15th day of the month of the letting.
3. All new contracts (and subcontracts) awarded earlier than five days before the letting date are included in the report and charged against our total rating.

I certify that the information above is correct.

NAME OF FIRM

Sworn to and subscribed this _____ day
of _____, 20 _____

By: _____

Title

STATE OF FLORIDA DEPARTMENT OF TRANSPORTATION
LAP CERTIFICATION OF CURRENT CAPACITY

525-010-46
PROGRAM MANAGEMENT
09/20
Page 2 of 2

CONFIDENTIAL per Ch 337.14(1) F.S.

(Furnish complete information about all your contracts, whether prime or subcontracts;
whether in progress or awarded, but not yet begun; and regardless of whom contracted with.)

1	2	3	4	5		6
PROJECTS OWNER, LOCATION AND DESCRIPTION	CONTRACT (OR SUBCONTRACT) AMOUNT	AMOUNT SUBLET TO OTHERS	BALANCE OF CONTRACT AMOUNT	UNCOMPLETED AMOUNT TO BE DONE BY YOU		
				AS PRIME CONTRACTOR	AS SUBCONTRACTOR	
NOTE: Columns 2 and 3 to show total contract (or subcontract) amounts. Column 4 to be difference between columns 2 and 3. Amount in columns 5 or 6 to be uncompleted portion of amount in column 4. All amounts to be shown to nearest \$100. The Contractor may consolidate and list as a single item all contracts which, individually, do not exceed 3% of total, and which, in the aggregate, amount to less than 20% of the total.			TOTALS	\$0.00	\$0.00	
			TOTAL UNCOMPLETED WORK ON HAND TO BE DONE BY YOU (TOTAL COLUMNS 5 AND 6)		\$0.00	

Instructions for Form:

The contractor must provide enough information through a Schedule "A" spreadsheet to determine which pay-item(s) are being sublet, the amounts, and cost. For sublet calculations, the amount will be calculated based on the actual contract unit price(s) unless there is a partial sublet. For partial sublets, use the unit prices from the actual sub-contract.

- 1) Enter the Date of the certification of sublet work was prepared.
- 2) Enter the sequential number of the request starting with number 1.
- 3) Enter the Federal Aid Project number for the Prime Contractor if any.
- 4) Enter the Financial Project Identification number of the Contract.
- 5) Enter the Contract number of the Contract with the Department.
- 6) Enter the County name where the work is being performed.
- 7) Enter the Name of the Prime Contractor.
- 8) Enter the FEID number of the Prime Contractor.
- 9) Enter the Original Contract dollar amount (round to nearest whole dollar).
- 10) Enter a "Y" in the space marked Change if any information on the line has changed since the previous certification of sublet work was prepared. Otherwise, leave blank.
- 11) Enter the Subcontractor names. Enter all the subcontractor(s) regardless of their tier.
- 12) Enter the tier number for the subcontractor. If the subcontractor works directly for the Prime Contractor, enter a "1". If he works one level below, enter a "2" and so on.
- 13) Enter the FEID number of the Subcontractor(s).
- 14) Enter the name of the pertinent Contractor or Subcontractor that hired subcontractor.
- 15) Enter a short description of the work to be performed.
- 16) Enter a "P" if any pay-item for the sublet is a partial sublet.
- 17) Enter the DBE status for the subcontractor: "D" for DBE, "N" for non-DBE.
- 18) The Department may require subcontractor to be prequalified with the Department as described in the Special Provisions and the Bid Solicitation Notice whenever construction projects contain certain classes of work that require specific expertise.
- 19) One (1) copy of this form shall be submitted to the District Office by the contractor.
- 20) To be signed by principal of the firm or someone with the delegated authority and notarized.
 - a) Note: Notary not required when form is digitally signed.

BOARD OF COUNTY COMMISSIONERS



Month xx, 2022

via Email

Company

Attn:

Address

Address

Email address

NOTICE OF AWARD

Reference: *Indian River County Bid No. 2024006*
Project Name: *TRANS-FLORIDA RAILWAY TRAIL FROM FELLSMERE TO WEST OF I-95*

Dear Mr./Ms. :

It is my pleasure to inform you that on [DATE] the Board of County Commissioners awarded the above-referenced project to your company. The following documents are required before the applicable County department can issue a "Notice to Proceed" letter.

1. Public Construction Bond (unrecorded) in the amount of **100%** of the award amount (**\$.....**).
2. Two Signed Copies of Enclosed Agreement.
3. Certificate of Insurance indicating coverage required by Article 5 of the General Conditions (section 00700 of the bid documents) and Supplemental Conditions (Section 00800 of the bid documents). Certificate(s) **must name Indian River County as additional insured** and must provide for a 30-day Notice of Cancellation.
4. W-9.

The Public Construction Bond must be executed in accordance with section 255.05(1)(a), Florida Statutes. Please submit the Bond, W-9, the Certificate(s) of Insurance and two fully-executed copies of the enclosed agreement to this office at the address provided below no later than [Due **DATE (15 days from award)**]. Failure to comply with the established deadline for submittal of required documents may be grounds for cancellation of award.

Thank you for your prompt attention and if you have any questions, please do not hesitate to contact our office.

Sincerely,

Jennifer Hyde
Purchasing Manager

cc: Engineering Division

Office of Management and Budget • Purchasing Division
1800 27th Street, Vero Beach, Florida 32960 • (772) 226-1416 • Fax: (772) 770-5140
E-mail: purchasing@ircgov.com

Notice of Award - 00510-1

SECTION 00520 Agreement (Public Works)

TABLE OF CONTENTS

<u>Title</u>	<u>Page</u>
<u>ARTICLE 1 - WORK</u>	2
<u>ARTICLE 2 - THE PROJECT</u>	2
<u>ARTICLE 3 - ENGINEER</u>	2
<u>ARTICLE 4 - CONTRACT TIMES</u>	2
<u>ARTICLE 5 - CONTRACT PRICE</u>	3
<u>ARTICLE 6 - PAYMENT PROCEDURES</u>	3
<u>ARTICLE 7 - INDEMNIFICATION</u>	5
<u>ARTICLE 8 - CONTRACTOR’S REPRESENTATIONS</u>	5
<u>ARTICLE 9 - CONTRACT DOCUMENTS</u>	6
<u>ARTICLE 10 - MISCELLANEOUS</u>	8

[The Remainder of THIS Page WAS LEFT BLANK INTENTIONALLY]

THIS AGREEMENT is by and between INDIAN RIVER COUNTY, a Political Subdivision of the State of Florida organized and existing under the Laws of the State of Florida, (hereinafter called OWNER)

and _____
(hereinafter called CONTRACTOR).

OWNER and CONTRACTOR, in consideration of the mutual covenants hereinafter set forth, agree as follows:

ARTICLE 1 - WORK

1.01 CONTRACTOR shall complete all Work as specified or indicated in the Contract Documents. The Work is generally described as follows:

FM# 446073-1-58-1 includes the construction of a 12-foot Trail consisting of a coquina base and an asphalt surface. The project further includes some drainage improvements, trail signage and sod.

ARTICLE 2 - THE PROJECT

2.01 The Project for which the Work under the Contract Documents may be the whole or only a part is generally described as follows:

Project Name: **TRANS-FLORIDA RAILWAY TRAIL FROM FELLSMERE TO WEST OF I-95**
County Project Number: **IRC-2115**
FM Number: **446073-1-58-01**
Bid Number: **2024006**
Project Address: **11090 Co Rd 512, Fellsmere, FL 32948**

ARTICLE 3 - ENGINEER

3.01 The Indian River County Public Works Department is hereinafter called the ENGINEER and will act as OWNER's representative, assume all duties and responsibilities, and have the rights and authority assigned to ENGINEER in the Contract Documents in connection with the completion of the Work in accordance with the Contract Documents.

ARTICLE 4 - CONTRACT TIMES

4.01 *Time of the Essence*

A. All time limits for Milestones, if any, Substantial Completion, and completion and readiness for final payment as stated in the Contract Documents are of the essence of the Contract.

4.02 *Days to Achieve Substantial Completion, Final Completion and Final Payment*

A. The Work will be substantially completed on or before the **90th** calendar day after the date when the Contract Times commence to run as provided in paragraph 2.03 of the General Conditions, and completed and ready for final payment in accordance with paragraph 14.07

Agreement (Public Works) REV 04-07 - 00520 - 2

of the General Conditions on or before the **120th** calendar day after the date when the Contract Times commence to run.

4.03 *Liquidated Damages*

- A. CONTRACTOR and OWNER recognize that time is of the essence of this Agreement and that OWNER will suffer financial loss if the Work is not completed within the times specified in paragraph 4.02 above, plus any extensions thereof allowed in accordance with Article 12 of the General Conditions. Liquidated damages will commence for this portion of work. The parties also recognize the delays, expense, and difficulties involved in proving in a legal proceeding the actual loss suffered by OWNER if the Work is not completed on time. Accordingly, instead of requiring any such proof, OWNER and CONTRACTOR agree that as liquidated damages for delay (but not as a penalty), CONTRACTOR shall pay OWNER **\$1,694.00** for each calendar day that expires after the time specified in paragraph 4.02 for Substantial Completion until the Work is substantially complete. After Substantial Completion, if CONTRACTOR shall neglect, refuse, or fail to complete the remaining Work within the Contract Time or any proper extension thereof granted by OWNER, CONTRACTOR shall pay OWNER **\$1,694.00** for each calendar day that expires after the time specified in paragraph 4.02 for completion and readiness for final payment until the Work is completed and ready for final payment.

ARTICLE 5 - CONTRACT PRICE

5.01 OWNER shall pay CONTRACTOR for completion of the Work in accordance with the Contract Documents, an amount in current funds equal to the sum of the amounts determined pursuant to paragraph 5.01.A and summarized in paragraph 5.01.B, below:

- A. For all Work, at the prices stated in CONTRACTOR's Bid, attached hereto as an exhibit.
- B. THE CONTRACT SUM subject to additions and deductions provided in the Contract:

Numerical Amount: \$ _____

Written Amount: _____

ARTICLE 6 - PAYMENT PROCEDURES

6.01 *Submittal and Processing of Payments*

- A. CONTRACTOR shall submit Applications for Payment in accordance with Article 14 of the General Conditions. Applications for Payment will be processed by ENGINEER as provided in the General Conditions and the Contract Documents.

6.02 *Progress Payments.*

- A. The OWNER shall make progress payments to the CONTRACTOR on the basis of the approved partial payment request as recommended by ENGINEER in accordance with the provisions of the Local Government Prompt Payment Act,

Agreement (Public Works) REV 04-07 - 00520 - 3

Florida Statutes section 218.70 et. seq. The OWNER shall retain five percent (5%) of the payment amounts due to the CONTRACTOR until substantial completion of all work to be performed by CONTRACTOR under the Contract Documents.

- B. For construction projects less than \$10 million, at the time the Owner is in receipt of the Certificate of Substantial Completion, the Owner shall have 30 calendar days to provide a list to the Contractor of items to be completed and the estimated cost to complete each item on the list. Owner and Contractor agree that the Contractor's itemized bid shall serve as the basis for determining the cost of each item on the list. For projects in excess of \$10 million, owner shall have up to 45 calendar days following receipt of Certificate of Substantial Completion of the project to provide contractor with said list.
- C. Payment of Retainage - Within 20 business days following the creation of the list, Owner shall pay Contractor the remaining contract balance including all retainage previously withheld by Owner except for an amount equal to 150% of the estimated cost to complete all of the items on the list. Upon completion of all items on the list, the Contractor may submit a payment request for the amount of the 150% retainage held by the Owner. If a good faith dispute exists as to whether one or more of the items have been finished, the owner may continue to withhold the 150% of the total cost to complete such items. The owner shall provide Contractor written reasons for disputing completion of the list.

6.03 *Pay Requests.*

- A. Each request for a progress payment shall be submitted on the application provided by OWNER and the application for payment shall contain the CONTRACTOR'S certification. All progress payments will be on the basis of progress of the work measured by the schedule of values established, or in the case of unit price work based on the number of units completed.

6.04 *Paragraphs 6.02 and 6.03*

do not apply to construction services work purchased by the County as OWNER which are paid for, in whole or in part, with federal funds and are subject to federal grantor laws and regulations or requirements that are contrary to any provision of the Local Government Prompt Payment Act. In such event, payment and retainage provisions shall be governed by the applicable grant requirements and guidelines.

6.05 *Acceptance of Final Payment as Release.*

- A. The acceptance by the CONTRACTOR of final payment shall be and shall operate as a release to the OWNER from all claims and all liability to the CONTRACTOR other than claims in stated amounts as may be specifically excepted by the CONTRACTOR for all things done or furnished in connection with the work under this Contract and for every act and neglect of the OWNER and others relating to or arising out of the work. Any payment, however, final or otherwise, shall not release the CONTRACTOR or its sureties from any obligations under the Contract Documents or the Public Construction Bond.

ARTICLE 7 - INDEMNIFICATION

7.01 CONTRACTOR shall indemnify OWNER, ENGINEER, and others in accordance with paragraph 6.20 (*Indemnification*) of the General Conditions to the Construction Contract.

ARTICLE 8 - CONTRACTOR'S REPRESENTATIONS

8.01 In order to induce OWNER to enter into this Agreement CONTRACTOR makes the following representations:

- A. CONTRACTOR has examined and carefully studied the Contract Documents and the other related data identified in the Bidding Documents.
- B. CONTRACTOR has visited the Site and become familiar with and is satisfied as to the general, local, and Site conditions that may affect cost, progress, and performance of the Work.
- C. CONTRACTOR is familiar with and is satisfied as to all federal, state, and local Laws and Regulations that may affect cost, progress, and performance of the Work.
- D. CONTRACTOR has carefully studied all: (1) reports of explorations and tests of subsurface conditions at or contiguous to the Site and all drawings of physical conditions in or relating to existing surface or subsurface structures at or contiguous to the Site (except Underground Facilities) which have been identified in the Supplementary Conditions as provided in paragraph 4.02 of the General Conditions and (2) reports and drawings of a Hazardous Environmental Condition, if any, at the Site which have been identified in the Supplementary Conditions as provided in paragraph 4.06 of the General Conditions.
- E. CONTRACTOR has obtained and carefully studied (or assumes responsibility for having done so) all additional or supplementary examinations, investigations, explorations, tests, studies, and data concerning conditions (surface, subsurface, and Underground Facilities) at or contiguous to the Site which may affect cost, progress, or performance of the Work or which relate to any aspect of the means, methods, techniques, sequences, and procedures of construction to be employed by CONTRACTOR, including applying the specific means, methods, techniques, sequences, and procedures of construction, if any, expressly required by the Contract Documents to be employed by CONTRACTOR, and safety precautions and programs incident thereto
- F. CONTRACTOR does not consider that any further examinations, investigations, explorations, tests, studies, or data are necessary for the performance of the Work at the Contract Price, within the Contract Times, and in accordance with the other terms and conditions of the Contract Documents.
- G. CONTRACTOR is aware of the general nature of work to be performed by OWNER and others at the Site that relates to the Work as indicated in the Contract Documents.
- H. CONTRACTOR has correlated the information known to CONTRACTOR, information and observations obtained from visits to the Site, reports and drawings identified in the Contract Documents, and all additional examinations, investigations, explorations, tests, studies, and data with the Contract Documents.
- I. CONTRACTOR has given ENGINEER written notice of all conflicts, errors, ambiguities, or discrepancies that CONTRACTOR has discovered in the Contract Documents, and the written resolution thereof by ENGINEER is acceptable to CONTRACTOR.

- J. The Contract Documents are generally sufficient to indicate and convey understanding of all terms and conditions for performance and furnishing of the Work.
- K. Contractor is registered with and will use the Department of Homeland Security's E-Verify system (www.e-verify.gov) to confirm the employment eligibility of all newly hired employees for the duration of this agreement, as required by Section 448.095, F.S. Contractor is also responsible for obtaining proof of E-Verify registration for all subcontractors.
- L. Neither the Recipient nor any of its CONTRACTORS or their subcontractors shall enter into any contract, subcontract or arrangement in connection with the Project or any property included or planned to be included in the Project in which any member, officer or employee of the Recipient or the locality during tenure or for 2 years thereafter has any interest, direct or indirect. If any such present or former member, officer or employee involuntarily acquires or had acquired prior to the beginning of tenure any such interest, and if such interest is immediately disclosed to the Recipient, the Recipient, with prior approval of the Department, may waive the prohibition contained in this paragraph provided that any such present member, officer or employee shall not participate in any action by the Recipient or the locality relating to such contract, subcontract or arrangement. The Recipient shall insert in all contracts entered into in connection with the Project or any property included or planned to be included in any Project, and shall require its CONTRACTORS to insert in each of their subcontracts, the following provision: "No member, officer or employee of the Recipient or of the locality during his tenure or for 2 years thereafter shall have any interest, direct or indirect, in this contract or the proceeds thereof." The provisions of this paragraph shall not be applicable to any agreement between the Recipient and its fiscal depositories or to any agreement for utility services the rates for which are fixed or controlled by a governmental agency.

ARTICLE 9 - CONTRACT DOCUMENTS

9.01 *Contents*

- A. The Contract Documents consist of the following:
 - 1. This Agreement (pages 00520-1 to 00520-11, inclusive);
 - 2. Notice to Proceed (page 00550-1);
 - 3. Public Construction Bond (pages 00610-1 to 00610-3, inclusive);
 - 4. Sample Certificate of Liability Insurance (page 00620-1);
 - 5. Contractor's Application for Payment (pages 00622-1 to 00622-6 inclusive);
 - 6. Certificate of Substantial Completion (pages 00630-1 to 00630-2, inclusive);
 - 7. Contractor's Final Certification of the Work (pages 00632-1 to 00632-2, inclusive);
 - 8. Professional Surveyor & Mapper's Certification as to Elevations and Locations of the Work (page 00634-1);
 - 9. General Conditions (pages 00700-1 to 00700-37, inclusive);

10. Supplementary Conditions (pages 00800-1 to 00800-12, inclusive);
11. Specifications as listed in Division 1 (General Requirements) and Division 2 (Technical Provisions);
12. Drawings consisting of a cover sheet (C1), and sheets numbered C1 through C30, inclusive, with each sheet bearing the following general title: Historic Trans Florida Rail Trail Extension;
13. Addenda (if applicable _____);
14. Appendices to this Agreement (enumerated as follows):
 - Appendix A – Permits
 - Appendix B – Indian River County Fertilizer Ordinances
 - Appendix C – Indian River County Traffic Engineering Special Conditions for Right of Way Construction
 - Appendix D – Required Contract Provisions Federal-Aid Construction Contracts
 - Appendix E – General Wage Decision Number: fl20230170, 1/6/2023
 - Appendix F – Vendor Eligibility Check Prior To Contract Award
15. CONTRACTOR'S BID (pages 00310-1 to 00310-6, inclusive);
16. Bid Bond (page 00430-1);
17. Sworn Statement Under Section 105.08, Indian River County Code, on Disclosure of Relationships (pages 00452-1 to 00452-2, inclusive);
18. Sworn Statement Under the Florida Trench Safety Act (pages 00454-1 to 00454-2, inclusive);
19. Qualifications Questionnaire (pages 00456-1 to 00456-3, inclusive);
20. List of Subcontractors (page 00458-1);
21. Certification Regarding Prohibition Against Contracting with Scrutinized Companies (page 00460-1);
22. DBE Package (pages 00470-1 to 00470-2, inclusive);
23. Non-Collusion Affidavit (pages 00472-1 to 00472-4, inclusive);
24. Certification for Disclosure of Lobbying Activities on Federal Aid Projects (pages 00474-1 to 00474-3, inclusive);
25. Certification Regarding Debarment, Suspension, Ineligibility and Voluntary Exclusion – Lower Tier Covered Transactions for Federal Aid Contracts (pages 00476-1 to 00476-2, inclusive);
26. Certification of Non-Segregation & Non-Discrimination (pages 00490-1 to 00490-2, inclusive);
27. Buy America Certification of Compliance (page 00492-1);

28. Drug Free Workplace Certification (page 00494-1);
29. LAP Certification of Capacity/Status of Contracts on Hand (pages 00496-1 to 00496-2, inclusive);
30. Certification to Sublet Work (pages 00500-1 to 00500-2, inclusive);
31. The following which may be delivered or issued on or after the Effective Date of the Agreement and are not attached hereto:
 - a) Written Amendments;
 - b) Work Change Directives;
 - c) Change Order(s);

ARTICLE 10 - MISCELLANEOUS

10.01 *Terms*

- A. Terms used in this Agreement will have the meanings indicated in the General Conditions.

10.02 *Assignment of Contract*

- A. No assignment by a party hereto of any rights under or interests in the Contract will be binding on another party hereto without the written consent of the party sought to be bound; and, specifically but without limitation, moneys that may become due and moneys that are due may not be assigned without such consent (except to the extent that the effect of this restriction may be limited by law), and unless specifically stated to the contrary in any written consent to an assignment, no assignment will release or discharge the assignor from any duty or responsibility under the Contract Documents.

10.03 *Successors and Assigns*

- A. OWNER and CONTRACTOR each binds itself, its partners, successors, assigns, and legal representatives to the other party hereto, its partners, successors, assigns, and legal representatives in respect to all covenants, agreements, and obligations contained in the Contract Documents.

10.04 *Severability*

- A. Any provision or part of the Contract Documents held to be void or unenforceable under any Law or Regulation shall be deemed stricken, and all remaining provisions shall continue to be valid and binding upon OWNER and CONTRACTOR, who agree that the Contract Documents shall be reformed to replace such stricken provision or part thereof with a valid and enforceable provision that comes as close as possible to expressing the intention of the stricken provision.

10.05 *Venue*

- A. This Contract shall be governed by the laws of the State of Florida. Venue for any lawsuit brought by either party against the other party or otherwise arising out of this Contract shall

be in Indian River County, Florida, or, in the event of a federal jurisdiction, in the United States District Court for the Southern District of Florida.

10.06 *Public Records Compliance*

A. Indian River County is a public agency subject to Chapter 119, Florida Statutes. The Contractor shall comply with Florida's Public Records Law. Specifically, the Contractor shall:

- (1) Keep and maintain public records required by the County to perform the service.
- (2) Upon request from the County's Custodian of Public Records, provide the County with a copy of the requested records or allow the records to be inspected or copied within a reasonable time at a cost that does not exceed the cost provided in Chapter 119 or as otherwise provided by law.
- (3) Ensure that public records that are exempt or confidential and exempt from public records disclosure requirements are not disclosed except as authorized by law for the duration of the contract term and following completion of the contract if the contractor does not transfer the records to the County.
- (4) Upon completion of the contract, transfer, at no cost, to the County all public records in possession of the Contractor or keep and maintain public records required by the County to perform the service. If the Contractor transfers all public records to the County upon completion of the contract, the Contractor shall destroy any duplicate public records that are exempt or confidential and exempt from public records disclosure requirements. If the contractor keeps and maintains public records upon completion of the contract, the Contractor shall meet all applicable requirements for retaining public records. All records stored electronically must be provided to the County, upon request from the Custodian of Public Records, in a format that is compatible with the information technology systems of the County.

B. IF THE CONTRACTOR HAS QUESTIONS REGARDING THE APPLICATION OF CHAPTER 119, FLORIDA STATUTES, TO THE CONTRACTOR'S DUTY TO PROVIDE PUBLIC RECORDS RELATING TO THIS CONTRACT, CONTACT THE CUSTODIAN OF PUBLIC RECORDS AT:

(772) 226-1424

publicrecords@ircgov.com

Indian River County Office of the County Attorney

1801 27th Street

Vero Beach, FL 32960

C. Failure of the Contractor to comply with these requirements shall be a material breach of this Agreement.

10.07 *Indemnification and Insurance*

A. Recipient agrees to include the following indemnification in all contracts with CONTRACTORS, subcontractors, consultants, or subconsultants (each referred to as

Agreement (Public Works) REV 04-07 - 00520 - 9

“Entity” for the purposes of the below indemnification) who perform work in connection with this Agreement:

“To the extent provided by law, [ENTITY] shall indemnify, defend, and hold harmless the [RECIPIENT] and the State of Florida, Department of Transportation, including the Department’s officers, agents, and employees, against any actions, claims, or damages arising out of, relating to, or resulting negligent or wrongful act(s) of [ENTITY], or any of its officers, agents, or employees, acting within the scope of their office or employment, in connection with the rights granted to or exercised by [ENTITY] hereunder, to the extent and within the limitations of Section 768.28, Florida Statutes.

The foregoing indemnification shall not constitute a waiver of sovereign immunity beyond the limits set forth in Florida Statutes, Section 768.28. Nor shall the same be construed to constitute agreement by [ENTITY] to indemnify [RECIPIENT] for the negligent acts or omissions of [RECIPIENT], its officers, agents, or employees, or third parties. Nor shall the same be construed to constitute agreement by [ENTITY] to indemnify the Department for the negligent acts or omissions of the Department, its officers, agents, or employees, or third parties. This indemnification shall survive the termination of this “Agreement.”

10.08 *Miscellaneous Provisions*

- A. The Parties agree to comply with s.20.055(5), Florida Statutes, and to incorporate in all subcontracts the obligation to comply with s.20.055(5), Florida Statutes.

[The remainder of this page was left blank intentionally]

IN WITNESS WHEREOF, OWNER and CONTRACTOR have signed this Agreement in duplicate. One counterpart each has been delivered to OWNER and CONTRACTOR. All portions of the Contract Documents have been signed or identified by OWNER and CONTRACTOR or on their behalf.

This Agreement will be effective on _____ day _____ of 20____ (the date the Contract is approved by the Indian River County Board of County Commissioners, which is the Effective Date of the Agreement).

OWNER:

CONTRACTOR:

INDIAN RIVER COUNTY _____

By: _____
Joseph Earman, Chairman

By: _____
(Contractor)

By: _____
John A. Titkanich, Jr., County Administrator

(CORPORATE SEAL)

Attest _____

APPROVED AS TO FORM AND LEGAL SUFFICIENCY:

By: _____
William K. DeBraul, County Attorney

Address for giving notices:

Ryan L. Butler, Clerk of Court and Comptroller

License No. _____
(Where applicable)

Attest: _____
Deputy Clerk

Agent for service of process: _____

(SEAL)

Designated Representative:
Name: Richard B. Szpyrka, P.E.
Title: Public Works Director
1801 27th Street
Vero Beach, Florida 32960
(772) 226-1379
Facsimile: (772) 226-1371

Designated Representative:
Name: _____
Title: _____
Address: _____

Phone: _____
Facsimile: _____

(If CONTRACTOR is a corporation or a partnership, attach evidence of authority to sign.)

*** * END OF SECTION * ***

SECTION 00550 – Notice to Proceed

Dated

TO:

(BIDDER)

ADDRESS:

Contract For:

TRANS-FLORIDA RAILWAY TRAIL FROM FELLSMERE TO WEST OF I-95

(Insert name of Contract as it appears in the Contract Documents)

Project No: **IRC-2115**
FM No: **446073-1-58-01**
IRC Bid No. **2024006**

You are notified that the Contract Times under the above contract will commence to run on _____. By that date, you are to start performing your obligations under the Contract Documents. The contract has allocated **90** calendar days for Substantial Completion of this project and **120** calendar days for Final Completion. In accordance with Article 4 of the Agreement the date of Substantial Completion is _____ and the date of readiness for final payment is _____.

CONTRACTOR shall not commence work under this Contract until he has obtained all insurance required under Article 5 and such insurance has been delivered to the OWNER and approved by the OWNER, nor shall the CONTRACTOR allow any Subcontractor to commence work on his subcontract until all similar insurance required of the Subcontractor has been so obtained and approved. All such insurance shall remain in effect until final payment and at all times thereafter when CONTRACTOR may be correcting, removing or replacing *defective* Work in accordance with Article 13.

Also, before you may start any Work at the Site, you must:
(add other requirements, if applicable)

INDIAN RIVER COUNTY
(OWNER)

By: _____
(AUTHORIZED SIGNATURE)

(TITLE)

SECTION 00610 - Public Construction Bond

INSTRUCTION FOR PUBLIC CONSTRUCTION BOND

The front or cover page to the required public construction payment and performance bond shall contain the information required by Fla. Stat. 255.05(1)(a), and be substantially in the format shown on the first page following this instruction.

The Public Construction Bond shall be in the form suggested by Fla. Stat. 255.05(3) as shown on the second page following this instruction.

A Power of Attorney from a surety insurer authorized to do business in Florida, authorizing the signature of the Attorney in Fact who executes the Public Construction Bond shall accompany that Bond.

**Public Work
F.S. Chapter 255.05 (1)(a)
Cover Page**

THIS BOND IS GIVEN TO COMPLY WITH SECTION 255.05 OR SECTION 713.23 FLORIDA STATUTES, AND ANY ACTION INSTITUTED BY A CLAIMANT UNDER THIS BOND FOR PAYMENT MUST BE IN ACCORDANCE WITH THE NOTICE AND TIME LIMITATION PROVISIONS IN SECTION 255.05(2) OR SECTION 713.23 FLORIDA STATUTES.

BOND NO: _____

CONTRACTOR NAME: _____

CONTRACTOR ADDRESS: _____

CONTRACTOR PHONE NO: _____

SURETY COMPANY NAME: _____

SURETY PRINCIPAL
BUSINESS ADDRESS: _____

SURETY PHONE NO: _____

OWNER NAME: _____

OWNER ADDRESS: _____

OWNER PHONE NO: _____

OBLIGEE NAME: _____
**(If contracting entity is different from
the owner, the contracting public entity)**

OBLIGEE ADDRESS: _____

OBLIGEE PHONE NO: _____

BOND AMOUNT: _____

CONTRACT NO:
(If applicable) _____

DESCRIPTION OF WORK: _____

PROJECT LOCATION: _____

LEGAL DESCRIPTION:
(If applicable) _____

FRONT PAGE

All other bond page(s) are deemed subsequent to this page regardless of any page number(s) that may be printed thereon.

PUBLIC CONSTRUCTION BOND

Bond No. _____
(enter bond number)

BY THIS BOND, We _____, as Principal and _____, a corporation, as Surety, are bound to _____, herein called Owner, in the sum of \$_____, for payment of which we bind ourselves, our heirs, personal representatives, successors, and assigns, jointly and severally.

THE CONDITION OF THIS BOND is that if Principal:

1. Performs the contract dated _____, _____, between Principal and Owner for construction of _____, the contract being made a part of this bond by reference, at the times and in the manner prescribed in the contract; and
2. Promptly makes payments to all claimants, as defined in Section [255.05\(1\)](#), Florida Statutes, supplying Principal with labor, materials, or supplies, used directly or indirectly by Principal in the prosecution of the work provided for in the contract; and
3. Pays Owner all losses, damages, expenses, costs, and attorney's fees, including appellate proceedings, that Owner sustains because of a default by Principal under the contract; and
4. Performs the guarantee of all work and materials furnished under the contract for the time specified in the contract, then this bond is void; otherwise it remains in full force.

Any action instituted by a claimant under this bond for payment must be in accordance with the notice and time limitation provisions in Section [255.05\(2\)](#), Florida Statutes.

Any changes in or under the contract documents and compliance or noncompliance with any formalities connected with the contract or the changes does not affect Surety's obligation under this bond.

DATED ON _____,

(Name of Principal)

By _____
(As Attorney in Fact)

(Name of Surety)

SECTION 620 – Sample Certificate of Liability Insurance

CERTIFICATE OF LIABILITY INSURANCE	
PRODUCER	THIS CERTIFICATE IS ISSUED AS A MATTER OF INFORMATION ONLY AND CONFERS NO RIGHTS UPON THE CERTIFICATE HOLDER. THIS CERTIFICATE DOES NOT AMEND, EXTEND OR ALTER THE COVERAGE AFFORDED BY THE POLICIES BELOW.
	COMPANIES AFFORDING COVERAGE
INSURED	COMPANY A -
	COMPANY B -
	COMPANY C -
	COMPANY D -
	COMPANY E -

COVERAGES

THIS IS TO CERTIFY THAT THE POLICIES OF INSURANCE LISTED BELOW HAVE BEEN ISSUED TO THE INSURED NAMED ABOVE FOR THE POLICY PERIOD INDICATED NOTWITHSTANDING ANY REQUIREMENT TERM OR CONDITION OF ANY CONTRACT OR OTHER DOCUMENT WITH RESPECT TO WHICH THIS CERTIFICATE MAY BE ISSUED OR MAY PERTAIN THE INSURANCE ACCORDED BY THE POLICIES DESCRIBED HEREIN IS SUBJECT TO ALL THE TERMS, EXCLUSIONS AND CONDITIONS OF SUCH POLICIES. LIMITS SHOWN MAY HAVE BEEN REDUCED BY PAID CLAIMS.							
INSR LTR	TYPE OF INSURANCE	POLICY NUMBER	POLICY EFFECTIVE DATE (MM/DD/YY)	POLICY EXPIRATION DATE (MM/D/YY)	LIMITS		
A	GENERAL LIABILITY <input type="checkbox"/> COMMERCIAL GENERAL LIABILITY <input type="checkbox"/> CLAIMS MADE - <input type="checkbox"/> OCCUR <input type="checkbox"/> <input type="checkbox"/> <input type="checkbox"/> <input type="checkbox"/>				EACH OCCURRENCE	\$ 1,000,000	
					FIRE DAMAGE (Any One Fire)	\$ 50,000	
					MED. EXP. (Any One Person)	\$ 5,000	
					PERSONAL & ADV INJURY	\$ 1,000,000	
					GENERAL AGGREGATE	\$ 1,000,000	
					PRODUCTS – COMP/OP AGG.	\$ 1,000,000	
						\$	
A	AUTOMOBILE LIABILITY <input type="checkbox"/> ANY AUTO <input type="checkbox"/> ALL OWNED AUTOS <input type="checkbox"/> SCHEDULED AUTOS <input type="checkbox"/> HIRED AUTOS <input type="checkbox"/> NON-OWNED AUTOS <input type="checkbox"/> <input type="checkbox"/>				COMBINED SINGLE LIMIT (Ea. Occurrence)	\$ 1,000,000	
					BODILY INJURY (Per Person)	\$	
					BODILY INJURY (Per Accident)	\$	
					PROPERTY DAMAGE	\$	
	GARAGE LIABILITY <input type="checkbox"/> <input type="checkbox"/>				AUTO ONLY – EA ACCIDENT	\$	
					OTHER THAN	EA ACC	\$
						AUTO ONLY	AGG
A	EXCESS LIABILITY <input type="checkbox"/> CLAIMS MADE <input type="checkbox"/> DEDUCTIBLE <input type="checkbox"/> RETENTION \$				EACH OCCURRENCE		
					AGGREGATE	\$	
						\$	
						\$	
A	WORKER'S COMPENSATION AND EMPLOYER'S LIABILITY THE PROPRIETOR/PARTNERS/ EXECUTIVE OFFICERS ARE: <input type="checkbox"/> INCL <input type="checkbox"/> EXCL				<input type="checkbox"/> WC STATUTORY LIMITS		
					E.L. EACH ACCIDENT	\$ 100,000	
					E.L. DISEASE – EA	\$ 500,000	
					E.L. DISEASE-POLICY LIMIT	\$ 100,000	
	OTHER: BUILDER'S RISK				FULL REPLACEMENT COST OF THE WORK		
DESCRIPTION OF OPERATIONS/LOCATIONS VEHICLES/SPECIAL ITEMS							
CERTIFICATE HOLDER		ADDITIONAL INSURED; INSURER LETTER:		CANCELLATION			
ADDITIONAL INSURED: INDIAN RIVER COUNTY 1801 27 TH STREET, VERO BEACH, FL 32960-3388				SHOULD ANY OF THE ABOVE DESCRIBED POLICIES BE CANCELLED BEFORE THE EXPIRATION DATE THEREOF, THE ISSUING COMPANY WILL ENDEAVOR TO MAIL 30 DAYS WRITTEN NOTICE TO THE CERTIFICATE HOLDER NAMED TO THE LEFT. FAILURE TO MAIL SUCH NOTICE SHALL IMPOSE NO OBLIGATION OR LIABILITY OF ANY KIND UPON THE COMPANY, ITS AGENTS OR REPRESENTATIVES.			
				AUTHORIZED REPRESENTATIVE			

SECTION 00622 – Contractor’s Application for Payment

Application for Payment No. _____.

For Work Accomplished through the period of _____ through _____.

To: Indian River County (OWNER)
 From: _____ (CONTRACTOR)

Project No.: IRC-2115
 FM No.: 446073-1-58-01
 Bid No.: 2024006

1) Attach detailed schedule and copies of all paid invoices.

1.	Original Contract Price:	\$ _____
2.	Net change by Change Orders and Written Amendments (+ or -):	\$ _____
3.	Current Contract Price (1 plus 2):	\$ _____
4.	Total completed and stored to date:	\$ _____
5.	Retainage (per Agreement):	
	5% of completed Work:	
	_____ % of retainage:	\$ _____
	Total Retainage:	\$ _____
6.	Total completed and stored to date less retainage (4 minus 5):	\$ _____
7.	Less previous Application for Payments:	\$ _____
8.	DUE THIS APPLICATION (6 MINUS 7):	\$ _____

CONTRACTOR'S CERTIFICATION:

UNDER PENALTY OF PERJURY, the undersigned CONTRACTOR certifies that (1) the labor and materials listed on this request for payment have been used in the construction of this Work; (2) payment received from the last pay request has been used to make payments to all subcontractors, laborers, materialmen and suppliers except as listed on Attachment A, below; (3) title of all Work, materials and equipment incorporated in said Work or otherwise listed in or covered by this Application for Payment will pass to OWNER at time of payment free and clear of all Liens, security interests and encumbrances (except such as are covered by a Bond acceptable to OWNER indemnifying OWNER against any such Lien, security interest or encumbrance); (4) all Work covered by this Application for Payment is in accordance with the Contract Documents and not defective; and (5) If this Periodic Estimate is for a Final Payment to project or improvement, I further certify that all persons doing work upon or furnishing materials or supplies for this project or improvement under this foregoing contract have been paid in full, and that all taxes imposed by Chapter 212 Florida Statutes, (Sales and Use Tax Act, as Amended) have been paid and discharged, and that I have no claims against the OWNER.

Attached to or submitted with this form are:

1. Signed release of lien forms (partial or final as applicable) from all subcontractors, laborers, materialmen and suppliers except as listed on Attachment A, together with an explanation as to why any release of lien form is not included;

2. Updated Construction Schedule per [Specification Section 01310](#).

Dated _____

By: _____
(CONTRACTOR – must be signed by
an Officer of the Corporation)

Print Name and Title

STATE OF _____

COUNTY OF _____

Sworn to (or affirmed) and subscribed before me by means of physical presence or online
notarization, this _____ day of _____ 20_____, by _____
(name of person making statement).

(Signature of Notary Public - State of Florida)
(Print, Type, or Stamp Commissioned Name of Notary Public)

who is personally known to me or who has produced
_____ as identification.

Please remit payment to:

Contractor's Name: _____

Address: _____

[The remainder of this page was left blank intentionally]

SURETY'S CONSENT OF PAYMENT TO CONTRACTOR:

The Surety, _____

_____, a
corporation, in accordance with Public Construction Bond Number _____, hereby
consents to payment by the OWNER to the CONTRACTOR, for the amounts specified in
this CONTRACTOR'S APPLICATION FOR PAYMENT.

TO BE EXECUTED BY CORPORATE SURETY:

Attest:

Secretary

Corporate Surety

Business Address

BY: _____

Print Name: _____

Title: _____

(Affix Corporate SEAL)

STATE OF FLORIDA
COUNTY OF INDIAN RIVER

Before me, a Notary Public, duly commissioned, qualified, and acting, personally appeared
_____, to me well known or who produced
_____ as identification, who being by me first duly sworn
upon oath, says that he/she is the _____ for
and that he/she has been authorized by _____ it to approve payment by the OWNER
to the CONTRACTOR of the foregoing Contractor's Application for Payment. Subscribed and
sworn to before me this ____ day of _____, 20____.

Notary Public, State of _____

My Commission Expires: _____

[The remainder of this page was left blank intentionally]

CERTIFICATION OF PROJECT MANAGER:

I certify that I have reviewed the above and foregoing Periodic Estimate for Partial Payment; that to the best of my knowledge and belief it appears to be a reasonably accurate statement of the work performed and/or material supplied by the Contractor. I am not certifying as to whether or not the Contractor has paid all subcontractors, laborers, materialmen and suppliers because I am not in a position to accurately determine that issue.

Dated _____

SIGNATURE

CERTIFICATION OF INSPECTOR:

I have checked the estimate against the Contractor's Schedule of Amounts for Contract Payments and the notes and reports of my inspections of the project. To the best of my knowledge, this statement of work performed and/or materials supplied appears to be reasonably accurate, that the Contractor appears to be observing the requirements of the Contract with respect to construction, and that the Contractor should be paid the amount requested above, unless otherwise noted by me. I am not certifying as to whether or not the Contractor has paid all subcontractors, laborers, materialmen and suppliers because I am not in a position to accurately determine that issue.

Dated _____

SIGNATURE

[The Remainder of This Page Was Left Blank Intentionally]

ATTACHMENT A

- 1. List of all subcontractors, laborers, materialmen and suppliers who have not been paid from the payment received from the last Pay Request and the reason why they were not paid (attach additional pages as necessary):**

- 2. List of all subcontractors, laborers, materialmen and suppliers for which a signed release of lien form (partial or final as applicable) is not included with this Pay Request, together with an explanation as to why the release of lien form is not included (attach additional pages as necessary):**

SECTION 00630 – Certificate of Substantial Completion

Date of Issuance: _____, 20____

OWNER: Indian River County
CONTRACTOR: _____
CONTRACT FOR: TRANS-FLORIDA RAILWAY TRAIL FROM FELLSMERE TO WEST OF I-95
Project No.: IRC-2115
FM No.: 446073-1-58-01

Project Description: ***The proposed project includes the construction of a 12-foot Trail consisting of a coquina base and an asphalt surface. The project further includes some drainage improvements, trail signage and sod.***

OWNER's Bid No. 2024006

This Certificate of Substantial Completion applies to all Work under the Contract Documents or to the following specified parts thereof:

To: _____
OWNER

And To: _____
CONTRACTOR

The Work to which this Certificate applies has been inspected by authorized representatives of OWNER, CONTRACTOR and ENGINEER, and that Work is hereby declared to be substantially complete in accordance with the Contract Documents on

DATE OF SUBSTANTIAL COMPLETION

A tentative list of items to be completed or corrected is attached hereto. This list may not be all-inclusive, and the failure to include an item in it does not alter the responsibility of CONTRACTOR to complete all the Work in accordance with the Contract Documents. The items in the tentative list shall be completed or corrected by CONTRACTOR within 30 calendar days of the above date of Substantial Completion.

The responsibilities between OWNER and CONTRACTOR for security, operation, safety, maintenance, heat, utilities, insurance and warranties and guarantees shall be as follows:

OWNER:

CONTRACTOR:

The following documents are attached to and made a part of this Certificate:

[For items to be attached see definition of Substantial Completion as supplemented and other specifically noted conditions precedent to achieving Substantial Completion as required by Contract Documents.]

This certificate does not constitute an acceptance of Work not in accordance with the Contract Documents nor is it a release of CONTRACTOR's obligation to complete the Work in accordance with the Contract Documents.

Executed by ENGINEER on: _____ (Date).

ENGINEER: _____

By: _____
(Authorized Signature)

CONTRACTOR accepts this Certificate of Substantial Completion on _____ (date).

CONTRACTOR: _____

By: _____
(Authorized Signature)

OWNER accepts this Certificate of Substantial Completion on _____ (date).

OWNER: INDIAN RIVER COUNTY _____

By: _____
(Authorized Signature)

*** * END OF SECTION * ***

**SECTION 00632 - CONTRACTOR'S FINAL CERTIFICATION OF
THE WORK**
(TO ACCOMPANY CONTRACTOR'S FINAL APPLICATION FOR PAYMENT)

PROJECT NAME: TRANS-FLORIDA RAILWAY TRAIL FROM FELLSMERE TO WEST
OF I-95
PROJECT NO: IRC-2115

STATE OF _____
COUNTY OF _____

Personally before me the undersigned officer, authorized by the laws of said state to administer oaths, comes _____, who on oath says: That he is the CONTRACTOR with whom Indian River County, Florida, a political subdivision of said state, did on the _____ day of _____, 20____, enter into a contract for the performance of certain work, more particularly described as follows:

The proposed project includes the construction of a 12-foot Trail consisting of a coquina base and an asphalt surface. The project further includes some drainage improvements, trail signage and sod.

UNDER PENALTY OF PERJURY, affiant further says that said construction has been completed and the Contract therefore fully performed and final payment is now due and that all liens of all firms and individuals contracting directly with or directly employed by such CONTRACTOR have been paid in full EXCEPT:

Name	Description/Amount
_____	_____
_____	_____

who have not been paid and who are due the amount set forth.

Affiant further says that:

1. CONTRACTOR has reviewed the Contract Documents.
2. CONTRACTOR has reviewed the Work for compliance with the Contract Documents.
3. CONTRACTOR has completed the Work in accordance with the Contract Documents.
4. All equipment and systems have been tested in the presence of the ENGINEER or his representative and are fully operational with no defects or deficiencies except as listed below.

-
-
-
5. The Work is complete and ready for final acceptance by the OWNER.
 6. CONTRACTOR hereby certifies that it has no claims against the OWNER.

(Corporate Seal)

(Contractor)

By: _____

STATE OF _____

COUNTY OF _____

Sworn to (or affirmed) and subscribed before me by means of physical presence or online notarization, this _____ day _____ of 20____, by _____

(name of person making statement).

(Signature of Notary Public - State of Florida)
(Print, Type, or Stamp Commissioned Name of Notary Public)

who is personally known to me or who has produced _____ as identification.

+ + END OF SECTION + +

SECTION 00634 - PROFESSIONAL SURVEYOR AND MAPPER'S CERTIFICATION AS TO ELEVATIONS AND LOCATIONS OF THE WORK

(TO BE COMPLETED BY A FLORIDA PROFESSIONAL SURVEYOR AND MAPPER RETAINED BY THE CONTRACTOR AND TO ACCOMPANY CONTRACTOR'S FINAL APPLICATION FOR PAYMENT)

I CERTIFY that I am a Florida Professional Surveyor and Mapper retained by:

(Insert name of CONTRACTOR)

Who is the CONTRACTOR for the following Project:

PROJECT NAME: TRANS-FLORIDA RAILWAY TRAIL FROM FELLSMERE TO WEST OF I-95

PROJECT # IRC-2115

I FURTHER CERTIFY that I have personally performed the survey work for the preparation of Record Drawings for the CONTRACTOR for this project or that such work was performed under my direct control and supervision.

I FURTHER CERTIFY that all constructed elevations and locations of the Work are in conformance with the Contract Documents, except for discrepancies listed below.

[Attach additional sheets as necessary]

(SURVEYOR'S SEAL)

CERTIFIED BY: _____

Printed Name: _____

Florida Professional Surveyor and Mapper Registration Number: _____

Date Signed and Sealed by Professional Surveyor and Mapper: _____

Company Name: _____

Company Address: _____

Telephone Number: _____

STANDARD
GENERAL CONDITIONS
OF THE
CONSTRUCTION CONTRACT

Prepared by

ENGINEERS JOINT CONTRACT DOCUMENTS COMMITTEE

and

Issued and Published Jointly By

PROFESSIONAL ENGINEERS IN PRIVATE PRACTICE
a practice division of the
NATIONAL SOCIETY OF PROFESSIONAL ENGINEERS

AMERICAN CONSULTING ENGINEERS COUNCIL

AMERICAN SOCIETY OF CIVIL ENGINEERS

This document has been approved and endorsed by

The Associated General Contractors of America

Construction Specifications Institute

Copyright ©1996

National Society of Professional Engineers
1420 King Street, Alexandria, VA 22314

American Consulting Engineers Council
1015 15th Street N.W., Washington, DC 20005

American Society of Civil Engineers
345 East 47th Street, New York, NY 10017

TABLE OF CONTENTS

Title	Page
ARTICLE 1 - DEFINITIONS AND TERMINOLOGY	1
1.01 <i>Defined Terms</i>	1
1.02 <i>Terminology</i>	3
ARTICLE 2 - PRELIMINARY MATTERS	4
2.01 <i>Delivery of Bonds</i>	4
2.02 <i>Copies of Documents</i>	4
2.03 <i>Commencement of Contract Times; Notice to Proceed</i>	4
2.04 <i>Starting the Work</i>	4
2.05 <i>Before Starting Construction</i>	4
2.06 <i>Preconstruction Conference</i>	5
2.07 <i>Initial Acceptance of Schedules</i>	5
ARTICLE 3 - CONTRACT DOCUMENTS: INTENT, AMENDING, REUSE.....	5
3.01 <i>Intent</i>	5
3.02 <i>Reference Standards</i>	5
3.03 <i>Reporting and Resolving Discrepancies</i>	6
3.04 <i>Amending and Supplementing Contract Documents</i>	6
3.05 <i>Reuse of Documents</i>	6
ARTICLE 4 - AVAILABILITY OF LANDS; SUBSURFACE AND PHYSICAL CONDITIONS; REFERENCE POINTS	6
4.01 <i>Availability of Lands</i>	6
4.02 <i>Subsurface and Physical Conditions</i>	7
4.03 <i>Differing Subsurface or Physical Conditions</i>	7
4.04 <i>Underground Facilities</i>	8
4.05 <i>Reference Points</i>	8
4.06 <i>Hazardous Environmental Condition at Site</i>	9
ARTICLE 5 - BONDS AND INSURANCE	10
5.01 <i>Performance, Payment, and Other Bonds</i>	10
5.02 <i>Licensed Sureties and Insurers</i>	10
5.03 <i>Certificates of Insurance</i>	10
5.04 <i>CONTRACTOR's Liability Insurance</i>	10
5.05 <i>OWNER's Liability Insurance</i>	11
5.06 <i>Property Insurance</i>	11
5.07 <i>Waiver of Rights</i>	12
5.08 <i>Receipt and Application of Insurance Proceeds</i>	13
5.09 <i>Acceptance of Bonds and Insurance; Option to Replace</i>	13
5.10 <i>Partial Utilization, Acknowledgment of Property Insurer</i>	13
ARTICLE 6 - CONTRACTOR'S RESPONSIBILITIES	13
6.01 <i>Supervision and Superintendence</i>	13
6.02 <i>Labor; Working Hours</i>	14
6.03 <i>Services, Materials, and Equipment</i>	14
6.04 <i>Progress Schedule</i>	14
6.05 <i>Substitutes and "Or-Equals"</i>	14
6.06 <i>Concerning Subcontractors, Suppliers, and Others</i>	16
6.07 <i>Patent Fees and Royalties</i>	16
6.08 <i>Permits</i>	17
6.09 <i>Laws and Regulations</i>	17
6.10 <i>Taxes</i>	17

6.11	<i>Use of Site and Other Areas</i>	17
6.12	Record Documents	18
6.13	<i>Safety and Protection</i>	18
6.14	<i>Safety Representative</i>	18
6.15	<i>Hazard Communication Programs</i>	18
6.16	<i>Emergencies</i>	19
6.17	<i>Shop Drawings and Samples</i>	19
6.18	<i>Continuing the Work</i>	20
6.19	<i>CONTRACTOR's General Warranty and Guarantee</i>	20
6.20	<i>Indemnification</i>	20
ARTICLE 7 - OTHER WORK		21
7.01	<i>Related Work at Site</i>	21
7.02	<i>Coordination</i>	21
ARTICLE 8 - OWNER'S RESPONSIBILITIES.....		22
8.01	<i>Communications to Contractor</i>	22
8.02	<i>Replacement of ENGINEER</i>	22
8.03	<i>Furnish Data</i>	22
8.04	<i>Pay Promptly When Due</i>	22
8.05	<i>Lands and Easements; Reports and Tests</i>	22
8.06	<i>Insurance</i>	22
8.07	<i>Change Orders</i>	22
8.08	<i>Inspections, Tests, and Approvals</i>	22
8.09	<i>Limitations on OWNER's Responsibilities</i>	22
8.10	<i>Undisclosed Hazardous Environmental Condition</i>	22
8.11	<i>Evidence of Financial Arrangements</i>	22
ARTICLE 9 - ENGINEER'S STATUS DURING CONSTRUCTION.....		22
9.01	<i>OWNER'S Representative</i>	22
9.02	<i>Visits to Site</i>	22
9.03	<i>Project Representative</i>	23
9.04	<i>Clarifications and Interpretations</i>	23
9.05	<i>Authorized Variations in Work</i>	23
9.06	<i>Rejecting Defective Work</i>	23
9.07	<i>Shop Drawings, Change Orders and Payments</i>	23
9.08	<i>Determinations for Unit Price Work</i>	23
9.09	<i>Decisions on Requirements of Contract Documents and Acceptability of Work</i>	23
9.10	<i>Limitations on ENGINEER's Authority and Responsibilities</i>	24
ARTICLE 10 - CHANGES IN THE WORK; CLAIMS		24
10.01	<i>Authorized Changes in the Work</i>	24
10.02	<i>Unauthorized Changes in the Work</i>	24
10.03	<i>Execution of Change Orders</i>	24
10.04	<i>Notification to Surety</i>	25
10.05	<i>Claims and Disputes</i>	25
ARTICLE 11 - COST OF THE WORK; CASH ALLOWANCES; UNIT PRICE WORK		25
11.01	<i>Cost of the Work</i>	25
11.02	<i>Cash Allowances</i>	27
11.03	<i>Unit Price Work</i>	27
ARTICLE 12 - CHANGE OF CONTRACT PRICE; CHANGE OF CONTRACT TIMES		28
12.01	<i>Change of Contract Price</i>	28
12.02	<i>Change of Contract Times</i>	29
12.03	<i>Delays Beyond CONTRACTOR's Control</i>	29
12.04	<i>Delays Within CONTRACTOR's Control</i>	29

12.05	Delays Beyond OWNER's and CONTRACTOR's Control	29
12.06	<i>Delay Damages</i>	29
ARTICLE 13	- TESTS AND INSPECTIONS; CORRECTION, REMOVAL OR ACCEPTANCE OF DEFECTIVE WORK.....	29
13.01	<i>Notice of Defects</i>	29
13.02	<i>Access to Work</i>	29
13.03	<i>Tests and Inspections</i>	29
13.04	<i>Uncovering Work</i>	30
13.05	<i>OWNER May Stop the Work</i>	30
13.06	<i>Correction or Removal of Defective Work</i>	30
13.07	<i>Correction Period</i>	31
13.08	<i>Acceptance of Defective Work</i>	31
13.09	<i>OWNER May Correct Defective Work</i>	31
ARTICLE 14	- PAYMENTS TO CONTRACTOR AND COMPLETION	32
14.01	<i>Schedule of Values</i>	32
14.02	<i>Progress Payments</i>	32
14.03	<i>CONTRACTOR's Warranty of Title</i>	34
14.04	<i>Substantial Completion</i>	34
14.05	<i>Partial Utilization</i>	34
14.06	<i>Final Inspection</i>	34
14.07	<i>Final Payment</i>	35
14.08	<i>Final Completion Delayed</i>	35
14.09	<i>Waiver of Claims</i>	35
ARTICLE 15	- SUSPENSION OF WORK AND TERMINATION.....	36
15.01	<i>OWNER May Suspend Work</i>	36
15.02	<i>OWNER May Terminate for Cause</i>	36
15.03	<i>OWNER May Terminate For Convenience</i>	36
15.04	<i>CONTRACTOR May Stop Work or Terminate</i>	37
ARTICLE 16	- DISPUTE RESOLUTION.....	37
16.01	<i>Methods and Procedures</i>	37
ARTICLE 17	- MISCELLANEOUS.....	37
17.01	<i>Giving Notice</i>	37
17.02	<i>Computation of Times</i>	37
17.03	<i>Cumulative Remedies</i>	37
17.04	<i>Survival of Obligations</i>	37
17.05	<i>Controlling Law</i>	37

GENERAL CONDITIONS

ARTICLE 1 - DEFINITIONS AND TERMINOLOGY

1.01 *Defined Terms*

A. Wherever used in the Contract Documents and printed with initial or all capital letters, the terms listed below will have the meanings indicated which are applicable to both the singular and plural thereof.

1. *Addenda*--Written or graphic instruments issued prior to the opening of Bids which clarify, correct, or change the Bidding Requirements or the Contract Documents.

2. *Agreement*--The written instrument which is evidence of the agreement between OWNER and CONTRACTOR covering the Work.

3. *Application for Payment*--The form acceptable to ENGINEER which is to be used by CONTRACTOR during the course of the Work in requesting progress or final payments and which is to be accompanied by such supporting documentation as is required by the Contract Documents.

4. *Asbestos*--Any material that contains more than one percent asbestos and is friable or is releasing asbestos fibers into the air above current action levels established by the United States Occupational Safety and Health Administration.

5. *Bid*--The offer or proposal of a bidder submitted on the prescribed form setting forth the prices for the Work to be performed.

6. *Bidding Documents*--The Bidding Requirements and the proposed Contract Documents (including all Addenda issued prior to receipt of Bids).

7. *Bidding Requirements*--The Advertisement or Invitation to Bid, Instructions to Bidders, Bid security form, if any, and the Bid form with any supplements.

8. *Bonds*--Performance and payment bonds and other instruments of security.

9. *Change Order*--A document recommended by ENGINEER which is signed by CONTRACTOR and OWNER and authorizes an addition, deletion, or revision in the Work or an adjustment in the Contract Price or the Contract Times, issued on or after the Effective Date of the Agreement.

10. *Claim*--A demand or assertion by OWNER or CONTRACTOR seeking an adjustment of Contract Price or Contract Times, or both, or other

relief with respect to the terms of the Contract. A demand for money or services by a third party is not a Claim.

11. *Contract*--The entire and integrated written agreement between the OWNER and CONTRACTOR concerning the Work. The Contract supersedes prior negotiations, representations, or agreements, whether written or oral.

12. *Contract Documents*--The Contract Documents establish the rights and obligations of the parties and include the Agreement, Addenda (which pertain to the Contract Documents), CONTRACTOR's Bid (including documentation accompanying the Bid and any post Bid documentation submitted prior to the Notice of Award) when attached as an exhibit to the Agreement, the Notice to Proceed, the Bonds, these General Conditions, the Supplementary Conditions, the Specifications and the Drawings as the same are more specifically identified in the Agreement, together with all Written Amendments, Change Orders, Work Change Directives, Field Orders, and ENGINEER's written interpretations and clarifications issued on or after the Effective Date of the Agreement. Approved Shop Drawings and the reports and drawings of subsurface and physical conditions are not Contract Documents. Only printed or hard copies of the items listed in this paragraph are Contract Documents. Files in electronic media format of text, data, graphics, and the like that may be furnished by OWNER to CONTRACTOR are not Contract Documents.

13. *Contract Price*--The moneys payable by OWNER to CONTRACTOR for completion of the Work in accordance with the Contract Documents as stated in the Agreement (subject to the provisions of paragraph 11.03 in the case of Unit Price Work).

14. *Contract Times*--The number of days or the dates stated in the Agreement to: (i) achieve Substantial Completion; and (ii) complete the Work so that it is ready for final payment as evidenced by ENGINEER's written recommendation of final payment.

15. *CONTRACTOR*--The individual or entity with whom OWNER has entered into the Agreement.

16. *Cost of the Work*--See paragraph 11.01.A for definition.

17. *Drawings*--That part of the Contract Documents prepared or approved by ENGINEER which graphically shows the scope, extent, and character of the Work to be performed by CONTRACTOR. Shop Drawings and other

CONTRACTOR submittals are not Drawings as so defined.

18. *Effective Date of the Agreement*--The date indicated in the Agreement on which it becomes effective, but if no such date is indicated, it means the date on which the Agreement is signed and delivered by the last of the two parties to sign and deliver.

19. *ENGINEER*--The individual or entity named as such in the Agreement.

20. *ENGINEER's Consultant*--An individual or entity having a contract with ENGINEER to furnish services as ENGINEER's independent professional associate or consultant with respect to the Project and who is identified as such in the Supplementary Conditions.

~~21. *Field Order*--A written order issued by ENGINEER which requires minor changes in the Work but which does not involve a change in the Contract Price or the Contract Times.~~

22. *General Requirements*--Sections of Division 1 of the Specifications. The General Requirements pertain to all sections of the Specifications.

23. *Hazardous Environmental Condition*--The presence at the Site of Asbestos, PCBs, Petroleum, Hazardous Waste, or Radioactive Material in such quantities or circumstances that may present a substantial danger to persons or property exposed thereto in connection with the Work.

24. *Hazardous Waste*--The term Hazardous Waste shall have the meaning provided in Section 1004 of the Solid Waste Disposal Act (42 USC Section 6903) as amended from time to time.

25. *Laws and Regulations; Laws or Regulations*--Any and all applicable laws, rules, regulations, ordinances, codes, and orders of any and all governmental bodies, agencies, authorities, and courts having jurisdiction.

26. *Liens*--Charges, security interests, or encumbrances upon Project funds, real property, or personal property.

27. *Milestone*--A principal event specified in the Contract Documents relating to an intermediate completion date or time prior to Substantial Completion of all the Work.

28. *Notice of Award*--The written notice by OWNER to the apparent successful bidder stating that upon timely compliance by the apparent successful bidder with the conditions precedent listed therein, OWNER will sign and deliver the Agreement.

29. *Notice to Proceed*--A written notice given by OWNER to CONTRACTOR fixing the date on which the Contract Times will commence to run and on which CONTRACTOR shall start to perform the Work under the Contract Documents.

30. *OWNER*--The individual, entity, public body, or authority with whom CONTRACTOR has entered into the Agreement and for whom the Work is to be performed.

31. *Partial Utilization*--Use by OWNER of a substantially completed part of the Work for the purpose for which it is intended (or a related purpose) prior to Substantial Completion of all the Work.

32. *PCBs*--Polychlorinated biphenyls.

33. *Petroleum*--Petroleum, including crude oil or any fraction thereof which is liquid at standard conditions of temperature and pressure (60 degrees Fahrenheit and 14.7 pounds per square inch absolute), such as oil, petroleum, fuel oil, oil sludge, oil refuse, gasoline, kerosene, and oil mixed with other non-Hazardous Waste and crude oils.

34. *Project*--The total construction of which the Work to be performed under the Contract Documents may be the whole, or a part as may be indicated elsewhere in the Contract Documents.

35. *Project Manual*--The bound documentary information prepared for bidding and constructing the Work. A listing of the contents of the Project Manual, which may be bound in one or more volumes, is contained in the table(s) of contents.

36. *Radioactive Material*--Source, special nuclear, or byproduct material as defined by the Atomic Energy Act of 1954 (42 USC Section 2011 et seq.) as amended from time to time.

37. *Resident Project Representative*--The authorized representative of ENGINEER who may be assigned to the Site or any part thereof.

38. *Samples*--Physical examples of materials, equipment, or workmanship that are representative of some portion of the Work and which establish the standards by which such portion of the Work will be judged.

39. *Shop Drawings*--All drawings, diagrams, illustrations, schedules, and other data or information which are specifically prepared or assembled by or for CONTRACTOR and submitted by CONTRACTOR to illustrate some portion of the Work.

40. *Site*--Lands or areas indicated in the Contract Documents as being furnished by OWNER
General Conditions - 00700 - 2

upon which the Work is to be performed, including rights-of-way and easements for access thereto, and such other lands furnished by OWNER which are designated for the use of CONTRACTOR.

41. *Specifications*--That part of the Contract Documents consisting of written technical descriptions of materials, equipment, systems, standards, and workmanship as applied to the Work and certain administrative details applicable thereto.

42. *Subcontractor*--An individual or entity having a direct contract with CONTRACTOR or with any other Subcontractor for the performance of a part of the Work at the Site.

43. *Substantial Completion*--The time at which the Work (or a specified part thereof) has progressed to the point where, in the opinion of ENGINEER, the Work (or a specified part thereof) is sufficiently complete, in accordance with the Contract Documents, so that the Work (or a specified part thereof) can be utilized for the purposes for which it is intended. The terms "substantially complete" and "substantially completed" as applied to all or part of the Work refer to Substantial Completion thereof.

44. *Supplementary Conditions*--That part of the Contract Documents which amends or supplements these General Conditions.

45. *Supplier*--A manufacturer, fabricator, supplier, distributor, materialman, or vendor having a direct contract with CONTRACTOR or with any Subcontractor to furnish materials or equipment to be incorporated in the Work by CONTRACTOR or any Subcontractor.

46. *Underground Facilities*--All underground pipelines, conduits, ducts, cables, wires, manholes, vaults, tanks, tunnels, or other such facilities or attachments, and any encasements containing such facilities, including those that convey electricity, gases, steam, liquid petroleum products, telephone or other communications, cable television, water, wastewater, storm water, other liquids or chemicals, or traffic or other control systems.

47. *Unit Price Work*--Work to be paid for on the basis of unit prices.

48. *Work*--The entire completed construction or the various separately identifiable parts thereof required to be provided under the Contract Documents. Work includes and is the result of performing or providing all labor, services, and documentation necessary to produce such construction, and furnishing, installing, and incorporating all materials and equipment into such construction, all as required by the Contract Documents.

49. *Work Change Directive*--A written statement to CONTRACTOR issued on or after the Effective Date of the Agreement and signed by OWNER and recommended by ENGINEER ordering an addition, deletion, or revision in the Work, or responding to differing or unforeseen subsurface or physical conditions under which the Work is to be performed or to emergencies. A Work Change Directive will not change the Contract Price or the Contract Times but is evidence that the parties expect that the change ordered or documented by a Work Change Directive will be incorporated in a subsequently issued Change Order following negotiations by the parties as to its effect, if any, on the Contract Price or Contract Times.

50. *Written Amendment*--A written statement modifying the Contract Documents, signed by OWNER and CONTRACTOR on or after the Effective Date of the Agreement and normally dealing with the nonengineering or nontechnical rather than strictly construction-related aspects of the Contract Documents.

1.02 *Terminology*

A. *Intent of Certain Terms or Adjectives*

1. Whenever in the Contract Documents the terms "as allowed," "as approved," or terms of like effect or import are used, or the adjectives "reasonable," "suitable," "acceptable," "proper," "satisfactory," or adjectives of like effect or import are used to describe an action or determination of ENGINEER as to the Work, it is intended that such action or determination will be solely to evaluate, in general, the completed Work for compliance with the requirements of and information in the Contract Documents and conformance with the design concept of the completed Project as a functioning whole as shown or indicated in the Contract Documents (unless there is a specific statement indicating otherwise). The use of any such term or adjective shall not be effective to assign to ENGINEER any duty or authority to supervise or direct the performance of the Work or any duty or authority to undertake responsibility contrary to the provisions of paragraph 9.10 or any other provision of the Contract Documents.

B. *Day*

1. The word "day" shall constitute a calendar day of 24 hours measured from midnight to the next midnight.

C. *Defective*

1. The word "defective," when modifying the word "Work," refers to Work that is unsatisfactory, faulty, or deficient in that it does

General Conditions - 00700 - 3

not conform to the Contract Documents or does not meet the requirements of any inspection, reference standard, test, or approval referred to in the Contract Documents, or has been damaged prior to ENGINEER's recommendation of final payment (unless responsibility for the protection thereof has been assumed by OWNER at Substantial Completion in accordance with paragraph 14.04 or 14.05).

D. *Furnish, Install, Perform, Provide*

~~1. The word "furnish," when used in connection with services, materials, or equipment, shall mean to supply and deliver said services, materials, or equipment to the Site (or some other specified location) ready for use or installation and in usable or operable condition.~~

~~2. The word "install," when used in connection with services, materials, or equipment, shall mean to put into use or place in final position said services, materials, or equipment complete and ready for intended use.~~

~~3. The words "perform" or "provide," when used in connection with services, materials, or equipment, shall mean to furnish and install said services, materials, or equipment complete and ready for intended use.~~

4. When "furnish," "install," "perform," or "provide" is not used in connection with services, materials, or equipment in a context clearly requiring an obligation of CONTRACTOR, "provide" is implied.

E. Unless stated otherwise in the Contract Documents, words or phrases which have a well-known technical or construction industry or trade meaning are used in the Contract Documents in accordance with such recognized meaning.

ARTICLE 2 - PRELIMINARY MATTERS

2.01 *Delivery of Bonds*

A. When CONTRACTOR delivers the executed Agreements to OWNER, CONTRACTOR shall also deliver to OWNER such Bonds as CONTRACTOR may be required to furnish.

2.02 *Copies of Documents*

A. OWNER shall furnish to CONTRACTOR up to ten copies of the Contract Documents. Additional copies will be furnished upon request at the cost of reproduction.

2.03 *Commencement of Contract Times; Notice to Proceed*

A. The Contract Times will commence to run on the thirtieth day after the Effective Date of the Agreement or, if a Notice to Proceed is given, on the day indicated in the Notice to Proceed. A Notice to Proceed may be given at any time within 30 days after the Effective Date of the Agreement. In no event will the Contract Times commence to run later than the ninetieth day after the day of Bid opening or the thirtieth day after the Effective Date of the Agreement, whichever date is earlier.

2.04 *Starting the Work*

A. CONTRACTOR shall start to perform the Work on the date when the Contract Times commence to run. No Work shall be done at the Site prior to the date on which the Contract Times commence to run.

2.05 *Before Starting Construction*

A. *CONTRACTOR's Review of Contract Documents:* Before undertaking each part of the Work, CONTRACTOR shall carefully study and compare the Contract Documents and check and verify pertinent figures therein and all applicable field measurements. CONTRACTOR shall promptly report in writing to ENGINEER any conflict, error, ambiguity, or discrepancy which CONTRACTOR may discover and shall obtain a written interpretation or clarification from ENGINEER before proceeding with any Work affected thereby; however, CONTRACTOR shall not be liable to OWNER or ENGINEER for failure to report any conflict, error, ambiguity, or discrepancy in the Contract Documents unless CONTRACTOR knew or reasonably should have known thereof.

B. *Preliminary Schedules:* Within ten days after the Effective Date of the Agreement (unless otherwise specified in the General Requirements), CONTRACTOR shall submit to ENGINEER for its timely review:

1. a preliminary progress schedule indicating the times (numbers of days or dates) for starting and completing the various stages of the Work, including any Milestones specified in the Contract Documents;

2. a preliminary schedule of Shop Drawing and Sample submittals which will list each required submittal and the times for submitting, reviewing, and processing such submittal; and

3. a preliminary schedule of values for all of the Work which includes quantities and prices of items which when added together equal the Contract Price and subdivides the Work into component parts in sufficient detail to serve as the basis for progress payments during performance of the Work. Such prices will include an appropriate amount of overhead and profit applicable to each item of Work.

~~C. Evidence of Insurance: Before any Work at the Site is started, CONTRACTOR and OWNER shall each deliver to the other, with copies to each additional insured identified in the Supplementary Conditions, certificates of insurance (and other evidence of insurance which either of them or any additional insured may reasonably request) which CONTRACTOR and OWNER respectively are required to purchase and maintain in accordance with Article 5.~~

2.06 Preconstruction Conference

~~A. Within 20 days after the Contract Times start to run, but before any Work at the Site is started, a conference attended by CONTRACTOR, ENGINEER, and others as appropriate will be held to establish a working understanding among the parties as to the Work and to discuss the schedules referred to in paragraph 2.05.B, procedures for handling Shop Drawings and other submittals, processing Applications for Payment, and maintaining required records.~~

2.07 Initial Acceptance of Schedules

A. Unless otherwise provided in the Contract Documents, at least ten days before submission of the first Application for Payment a conference attended by CONTRACTOR, ENGINEER, and others as appropriate will be held to review for acceptability to ENGINEER as provided below the schedules submitted in accordance with paragraph 2.05.B. CONTRACTOR shall have an additional ten days to make corrections and adjustments and to complete and resubmit the schedules. No progress payment shall be made to CONTRACTOR until acceptable schedules are submitted to ENGINEER.

1. The progress schedule will be acceptable to ENGINEER if it provides an orderly progression of the Work to completion within any specified Milestones and the Contract Times. Such acceptance will not impose on ENGINEER responsibility for the progress schedule, for sequencing, scheduling, or progress of the Work nor interfere with or relieve CONTRACTOR from CONTRACTOR's full responsibility therefor.

2. CONTRACTOR's schedule of Shop Drawing and Sample submittals will be acceptable to ENGINEER if it provides a

workable arrangement for reviewing and processing the required submittals.

3. CONTRACTOR's schedule of values will be acceptable to ENGINEER as to form and substance if it provides a reasonable allocation of the Contract Price to component parts of the Work.

ARTICLE 3 - CONTRACT DOCUMENTS: INTENT, AMENDING, REUSE

3.01 Intent

A. The Contract Documents are complementary; what is called for by one is as binding as if called for by all.

B. It is the intent of the Contract Documents to describe a functionally complete Project (or part thereof) to be constructed in accordance with the Contract Documents. Any labor, documentation, services, materials, or equipment that may reasonably be inferred from the Contract Documents or from prevailing custom or trade usage as being required to produce the intended result will be provided whether or not specifically called for at no additional cost to OWNER.

C. Clarifications and interpretations of the Contract Documents shall be issued by ENGINEER as provided in Article 9.

3.02 Reference Standards

A. *Standards, Specifications, Codes, Laws, and Regulations*

1. Reference to standards, specifications, manuals, or codes of any technical society, organization, or association, or to Laws or Regulations, whether such reference be specific or by implication, shall mean the standard, specification, manual, code, or Laws or Regulations in effect at the time of opening of Bids (or on the Effective Date of the Agreement if there were no Bids), except as may be otherwise specifically stated in the Contract Documents.

2. No provision of any such standard, specification, manual or code, or any instruction of a Supplier shall be effective to change the duties or responsibilities of OWNER, CONTRACTOR, or ENGINEER, or any of their subcontractors, consultants, agents, or employees from those set forth in the Contract Documents, nor shall any such provision or instruction be effective to assign to OWNER,

General Conditions - 00700 - 5

ENGINEER, or any of ENGINEER's Consultants, agents, or employees any duty or authority to supervise or direct the performance of the Work or any duty or authority to undertake responsibility inconsistent with the provisions of the Contract Documents.

3.03 *Reporting and Resolving Discrepancies*

A. *Reporting Discrepancies*

1. If, during the performance of the Work, CONTRACTOR discovers any conflict, error, ambiguity, or discrepancy within the Contract Documents or between the Contract Documents and any provision of any Law or Regulation applicable to the performance of the Work or of any standard, specification, manual or code, or of any instruction of any Supplier, CONTRACTOR shall report it to ENGINEER in writing at once. CONTRACTOR shall not proceed with the Work affected thereby (except in an emergency as required by paragraph 6.16.A) until an amendment or supplement to the Contract Documents has been issued by one of the methods indicated in paragraph 3.04; provided, however, that CONTRACTOR shall not be liable to OWNER or ENGINEER for failure to report any such conflict, error, ambiguity, or discrepancy unless CONTRACTOR knew or reasonably should have known thereof.

B. *Resolving Discrepancies*

1. Except as may be otherwise specifically stated in the Contract Documents, the provisions of the Contract Documents shall take precedence in resolving any conflict, error, ambiguity, or discrepancy between the provisions of the Contract Documents and:

a. the provisions of any standard, specification, manual, code, or instruction (whether or not specifically incorporated by reference in the Contract Documents); or

b. the provisions of any Laws or Regulations applicable to the performance of the Work (unless such an interpretation of the provisions of the Contract Documents would result in violation of such Law or Regulation).

3.04 *Amending and Supplementing Contract Documents*

A. The Contract Documents may be amended to provide for additions, deletions, and revisions in the Work or to modify the terms and conditions thereof in one or more of the following ways: (i) a Written Amend-

ment; (ii) a Change Order; or (iii) a Work Change Directive.

B. The requirements of the Contract Documents may be supplemented, and minor variations and deviations in the Work may be authorized, by one or more of the following ways: ~~(i) a Field Order~~; (ii) ENGINEER's approval of a Shop Drawing or Sample; or (iii) ENGINEER's written interpretation or clarification.

3.05 *Reuse of Documents*

A. CONTRACTOR and any Subcontractor or Supplier or other individual or entity performing or furnishing any of the Work under a direct or indirect contract with OWNER: (i) shall not have or acquire any title to or ownership rights in any of the Drawings, Specifications, or other documents (or copies of any thereof) prepared by or bearing the seal of ENGINEER or ENGINEER's Consultant, including electronic media editions; and (ii) shall not reuse any of such Drawings, Specifications, other documents, or copies thereof on extensions of the Project or any other project without written consent of OWNER and ENGINEER and specific written verification or adaption by ENGINEER. This prohibition will survive final payment, completion, and acceptance of the Work, or termination or completion of the Contract. Nothing herein shall preclude CONTRACTOR from retaining copies of the Contract Documents for record purposes.

ARTICLE 4 - AVAILABILITY OF LANDS; SUBSURFACE AND PHYSICAL CONDITIONS; REFERENCE POINTS

4.01 *Availability of Lands*

A. OWNER shall furnish the Site. OWNER shall notify CONTRACTOR of any encumbrances or restrictions not of general application but specifically related to use of the Site with which CONTRACTOR must comply in performing the Work. OWNER will obtain in a timely manner and pay for easements for permanent structures or permanent changes in existing facilities. If CONTRACTOR and OWNER are unable to agree on entitlement to or on the amount or extent, if any, of any adjustment in the Contract Price or Contract Times, or both, as a result of any delay in OWNER's furnishing the Site, CONTRACTOR may make a Claim therefor as provided in paragraph 10.05.

B. Upon reasonable written request, OWNER shall furnish CONTRACTOR with a current statement of record legal title and legal description of the lands upon which the Work is to be performed and OWNER's interest therein as necessary for giving notice of or filing a mechanic's or construction lien against such

lands in accordance with applicable Laws and Regulations.

C. CONTRACTOR shall provide for all additional lands and access thereto that may be required for temporary construction facilities or storage of materials and equipment.

4.02 *Subsurface and Physical Conditions*

A. *Reports and Drawings:* The Supplementary Conditions identify:

1. those reports of explorations and tests of subsurface conditions at or contiguous to the Site that ENGINEER has used in preparing the Contract Documents; and

2. those drawings of physical conditions in or relating to existing surface or subsurface structures at or contiguous to the Site (except Underground Facilities) that ENGINEER has used in preparing the Contract Documents.

B. *Limited Reliance by CONTRACTOR on Technical Data Authorized:* CONTRACTOR may rely upon the general accuracy of the "technical data" contained in such reports and drawings, but such reports and drawings are not Contract Documents. Such "technical data" is identified in the Supplementary Conditions. Except for such reliance on such "technical data," CONTRACTOR may not rely upon or make any Claim against OWNER, ENGINEER, or any of ENGINEER's Consultants with respect to:

1. the completeness of such reports and drawings for CONTRACTOR's purposes, including, but not limited to, any aspects of the means, methods, techniques, sequences, and procedures of construction to be employed by CONTRACTOR, and safety precautions and programs incident thereto; or

2. other data, interpretations, opinions, and information contained in such reports or shown or indicated in such drawings; or

3. any CONTRACTOR interpretation of or conclusion drawn from any "technical data" or any such other data, interpretations, opinions, or information.

4.03 *Differing Subsurface or Physical Conditions*

A. *Notice:* If CONTRACTOR believes that any subsurface or physical condition at or contiguous to the Site that is uncovered or revealed either:

1. is of such a nature as to establish that any "technical data" on which CONTRACTOR is

entitled to rely as provided in paragraph 4.02 is materially inaccurate; or

2. is of such a nature as to require a change in the Contract Documents; or

3. differs materially from that shown or indicated in the Contract Documents; or

4. is of an unusual nature, and differs materially from conditions ordinarily encountered and generally recognized as inherent in work of the character provided for in the Contract Documents;

then CONTRACTOR shall, promptly after becoming aware thereof and before further disturbing the subsurface or physical conditions or performing any Work in connection therewith (except in an emergency as required by paragraph 6.16.A), notify OWNER and ENGINEER in writing about such condition. CONTRACTOR shall not further disturb such condition or perform any Work in connection therewith (except as aforesaid) until receipt of written order to do so.

B. *ENGINEER's Review:* After receipt of written notice as required by paragraph 4.03.A, ENGINEER will promptly review the pertinent condition, determine the necessity of OWNER's obtaining additional exploration or tests with respect thereto, and advise OWNER in writing (with a copy to CONTRACTOR) of ENGINEER's findings and conclusions.

C. *Possible Price and Times Adjustments*

1. The Contract Price or the Contract Times, or both, will be equitably adjusted to the extent that the existence of such differing subsurface or physical condition causes an increase or decrease in CONTRACTOR's cost of, or time required for, performance of the Work; subject, however, to the following:

a. such condition must meet any one or more of the categories described in paragraph 4.03.A; and

b. with respect to Work that is paid for on a Unit Price Basis, any adjustment in Contract Price will be subject to the provisions of paragraphs 9.08 and 11.03.

2. CONTRACTOR shall not be entitled to any adjustment in the Contract Price or Contract Times if:

a. CONTRACTOR knew of the existence of such conditions at the time CONTRACTOR made a final commitment to OWNER in respect of Contract Price and Contract Times by the submission of a Bid or General Conditions - 00700 - 7

becoming bound under a negotiated contract; or

b. the existence of such condition could reasonably have been discovered or revealed as a result of any examination, investigation, exploration, test, or study of the Site and contiguous areas required by the Bidding Requirements or Contract Documents to be conducted by or for CONTRACTOR prior to CONTRACTOR's making such final commitment; or

c. CONTRACTOR failed to give the written notice within the time and as required by paragraph 4.03.A.

3. If OWNER and CONTRACTOR are unable to agree on entitlement to or on the amount or extent, if any, of any adjustment in the Contract Price or Contract Times, or both, a Claim may be made therefor as provided in paragraph 10.05. However, OWNER, ENGINEER, and ENGINEER's Consultants shall not be liable to CONTRACTOR for any claims, costs, losses, or damages (including but not limited to all fees and charges of engineers, architects, attorneys, and other professionals and all court or arbitration or other dispute resolution costs) sustained by CONTRACTOR on or in connection with any other project or anticipated project.

4.04 *Underground Facilities*

A. *Shown or Indicated*: The information and data shown or indicated in the Contract Documents with respect to existing Underground Facilities at or contiguous to the Site is based on information and data furnished to OWNER or ENGINEER by the owners of such Underground Facilities, including OWNER, or by others. Unless it is otherwise expressly provided in the Supplementary Conditions:

1. OWNER and ENGINEER shall not be responsible for the accuracy or completeness of any such information or data; and

2. the cost of all of the following will be included in the Contract Price, and CONTRACTOR shall have full responsibility for:

a. reviewing and checking all such information and data,

b. locating all Underground Facilities shown or indicated in the Contract Documents,

c. coordination of the Work with the owners of such Underground Facilities, including OWNER, during construction, and

d. the safety and protection of all such Underground Facilities and repairing any damage thereto resulting from the Work.

B. *Not Shown or Indicated*

1. If an Underground Facility is uncovered or revealed at or contiguous to the Site which was not shown or indicated, or not shown or indicated with reasonable accuracy in the Contract Documents, CONTRACTOR shall, promptly after becoming aware thereof and before further disturbing conditions affected thereby or performing any Work in connection therewith (except in an emergency as required by paragraph 6.16.A), identify the owner of such Underground Facility and give written notice to that owner and to OWNER and ENGINEER. ENGINEER will promptly review the Underground Facility and determine the extent, if any, to which a change is required in the Contract Documents to reflect and document the consequences of the existence or location of the Underground Facility. During such time, CONTRACTOR shall be responsible for the safety and protection of such Underground Facility.

2. If ENGINEER concludes that a change in the Contract Documents is required, a Work Change Directive or a Change Order will be issued to reflect and document such consequences. An equitable adjustment shall be made in the Contract Price or Contract Times, or both, to the extent that they are attributable to the existence or location of any Underground Facility that was not shown or indicated or not shown or indicated with reasonable accuracy in the Contract Documents and that CONTRACTOR did not know of and could not reasonably have been expected to be aware of or to have anticipated. If OWNER and CONTRACTOR are unable to agree on entitlement to or on the amount or extent, if any, of any such adjustment in Contract Price or Contract Times, OWNER or CONTRACTOR may make a Claim therefor as provided in paragraph 10.05.

4.05 *Reference Points*

A. OWNER shall provide engineering surveys to establish reference points for construction which in ENGINEER's judgment are necessary to enable CONTRACTOR to proceed with the Work. CONTRACTOR shall be responsible for laying out the Work, shall protect and preserve the established reference points

General Conditions - 00700 - 8

and property monuments, and shall make no changes or relocations without the prior written approval of OWNER. CONTRACTOR shall report to ENGINEER whenever any reference point or property monument is lost or destroyed or requires relocation because of necessary changes in grades or locations, and shall be responsible for the accurate replacement or relocation of such reference points or property monuments by professionally qualified personnel.

4.06 *Hazardous Environmental Condition at Site*

A. *Reports and Drawings:* Reference is made to the Supplementary Conditions for the identification of those reports and drawings relating to a Hazardous Environmental Condition identified at the Site, if any, that have been utilized by the ENGINEER in the preparation of the Contract Documents.

B. *Limited Reliance by CONTRACTOR on Technical Data Authorized:* CONTRACTOR may rely upon the general accuracy of the "technical data" contained in such reports and drawings, but such reports and drawings are not Contract Documents. Such "technical data" is identified in the Supplementary Conditions. Except for such reliance on such "technical data," CONTRACTOR may not rely upon or make any Claim against OWNER, ENGINEER or any of ENGINEER's Consultants with respect to:

1. the completeness of such reports and drawings for CONTRACTOR's purposes, including, but not limited to, any aspects of the means, methods, techniques, sequences and procedures of construction to be employed by CONTRACTOR and safety precautions and programs incident thereto; or
2. other data, interpretations, opinions and information contained in such reports or shown or indicated in such drawings; or
3. any CONTRACTOR interpretation of or conclusion drawn from any "technical data" or any such other data, interpretations, opinions or information.

C. CONTRACTOR shall not be responsible for any Hazardous Environmental Condition uncovered or revealed at the Site which was not shown or indicated in Drawings or Specifications or identified in the Contract Documents to be within the scope of the Work. CONTRACTOR shall be responsible for a Hazardous Environmental Condition created with any materials brought to the Site by CONTRACTOR, Subcontractors, Suppliers, or anyone else for whom CONTRACTOR is responsible.

D. If CONTRACTOR encounters a Hazardous Environmental Condition or if CONTRACTOR or anyone for whom CONTRACTOR is responsible

creates a Hazardous Environmental Condition, CONTRACTOR shall immediately: (i) secure or otherwise isolate such condition; (ii) stop all Work in connection with such condition and in any area affected thereby (except in an emergency as required by paragraph 6.16); and (iii) notify OWNER and ENGINEER (and promptly thereafter confirm such notice in writing). OWNER shall promptly consult with ENGINEER concerning the necessity for OWNER to retain a qualified expert to evaluate such condition or take corrective action, if any.

E. CONTRACTOR shall not be required to resume Work in connection with such condition or in any affected area until after OWNER has obtained any required permits related thereto and delivered to CONTRACTOR written notice: (i) specifying that such condition and any affected area is or has been rendered safe for the resumption of Work; or (ii) specifying any special conditions under which such Work may be resumed safely. If OWNER and CONTRACTOR cannot agree as to entitlement to or on the amount or extent, if any, of any adjustment in Contract Price or Contract Times, or both, as a result of such Work stoppage or such special conditions under which Work is agreed to be resumed by CONTRACTOR, either party may make a Claim therefor as provided in paragraph 10.05.

F. If after receipt of such written notice CONTRACTOR does not agree to resume such Work based on a reasonable belief it is unsafe, or does not agree to resume such Work under such special conditions, then OWNER may order the portion of the Work that is in the area affected by such condition to be deleted from the Work. If OWNER and CONTRACTOR cannot agree as to entitlement to or on the amount or extent, if any, of an adjustment in Contract Price or Contract Times as a result of deleting such portion of the Work, then either party may make a Claim therefor as provided in paragraph 10.05. OWNER may have such deleted portion of the Work performed by OWNER's own forces or others in accordance with Article 7.

G. To the fullest extent permitted by Laws and Regulations, OWNER shall indemnify and hold harmless CONTRACTOR, Subcontractors, ENGINEER, ENGINEER's Consultants and the officers, directors, partners, employees, agents, other consultants, and subcontractors of each and any of them from and against all claims, costs, losses, and damages (including but not limited to all fees and charges of engineers, architects, attorneys, and other professionals and all court or arbitration or other dispute resolution costs) arising out of or relating to a Hazardous Environmental Condition, provided that such Hazardous Environmental Condition: (i) was not shown or indicated in the Drawings or Specifications or identified in the Contract Documents to be included within the scope of the Work, and (ii) was not created

General Conditions - 00700 - 9

by CONTRACTOR or by anyone for whom CONTRACTOR is responsible. Nothing in this paragraph 4.06.E shall obligate OWNER to indemnify any individual or entity from and against the consequences of that individual's or entity's own negligence.

H. To the fullest extent permitted by Laws and Regulations, CONTRACTOR shall indemnify and hold harmless OWNER, ENGINEER, ENGINEER's Consultants, and the officers, directors, partners, employees, agents, other consultants, and subcontractors of each and any of them from and against all claims, costs, losses, and damages (including but not limited to all fees and charges of engineers, architects, attorneys, and other professionals and all court or arbitration or other dispute resolution costs) arising out of or relating to a Hazardous Environmental Condition created by CONTRACTOR or by anyone for whom CONTRACTOR is responsible. Nothing in this paragraph 4.06.F shall obligate CONTRACTOR to indemnify any individual or entity from and against the consequences of that individual's or entity's own negligence.

I. The provisions of paragraphs 4.02, 4.03, and 4.04 are not intended to apply to a Hazardous Environmental Condition uncovered or revealed at the Site.

ARTICLE 5 - BONDS AND INSURANCE

5.01 *Performance, Payment, and Other Bonds*

~~A. CONTRACTOR shall furnish performance and payment Bonds, each in an amount at least equal to the Contract Price as security for the faithful performance and payment of all CONTRACTOR's obligations under the Contract Documents. These Bonds shall remain in effect at least until one year after the date when final payment becomes due, except as provided otherwise by Laws or Regulations or by the Contract Documents. CONTRACTOR shall also furnish such other Bonds as are required by the Contract Documents.~~

B. All Bonds shall be in the form prescribed by the Contract Documents except as provided otherwise by Laws or Regulations, and shall be executed by such sureties as are named in the current list of "Companies Holding Certificates of Authority as Acceptable Sureties on Federal Bonds and as Acceptable Reinsuring Companies" as published in Circular 570 (amended) by the Financial Management Service, Surety Bond Branch, U.S. Department of the Treasury. All Bonds signed by an agent must be accompanied by a certified copy of such agent's authority to act.

C. If the surety on any Bond furnished by CONTRACTOR is declared bankrupt or becomes insolvent or its right to do business is terminated in any state where any part of the Project is located or it ceases to meet the requirements of paragraph 5.01.B, CONTRACTOR shall within 20 days thereafter substitute another Bond and surety, both of which shall comply with the requirements of paragraphs 5.01.B and 5.02.

5.02 *Licensed Sureties and Insurers*

A. All Bonds and insurance required by the Contract Documents to be purchased and maintained by OWNER or CONTRACTOR shall be obtained from surety or insurance companies that are duly licensed or authorized in the jurisdiction in which the Project is located to issue Bonds or insurance policies for the limits and coverages so required. Such surety and insurance companies shall also meet such additional requirements and qualifications as may be provided in the Supplementary Conditions.

5.03 *Certificates of Insurance*

A. CONTRACTOR shall deliver to OWNER, with copies to each additional insured identified in the Supplementary Conditions, certificates of insurance (and other evidence of insurance requested by OWNER or any other additional insured) which CONTRACTOR is required to purchase and maintain. ~~OWNER shall deliver to CONTRACTOR, with copies to each additional insured identified in the Supplementary Conditions, certificates of insurance (and other evidence of insurance requested by CONTRACTOR or any other additional insured) which OWNER is required to purchase and maintain.~~

5.04 *CONTRACTOR's Liability Insurance*

A. CONTRACTOR shall purchase and maintain such liability and other insurance as is appropriate for the Work being performed and as will provide protection from claims set forth below which may arise out of or result from CONTRACTOR's performance of the Work and CONTRACTOR's other obligations under the Contract Documents, whether it is to be performed by CONTRACTOR, any Subcontractor or Supplier, or by anyone directly or indirectly employed by any of them to perform any of the Work, or by anyone for whose acts any of them may be liable:

1. claims under workers' compensation, disability benefits, and other similar employee benefit acts;
2. claims for damages because of bodily injury, occupational sickness or disease, or death of CONTRACTOR's employees;

3. claims for damages because of bodily injury, sickness or disease, or death of any person other than CONTRACTOR's employees;

4. claims for damages insured by reasonably available personal injury liability coverage which are sustained: (i) by any person as a result of an offense directly or indirectly related to the employment of such person by CONTRACTOR, or (ii) by any other person for any other reason;

5. claims for damages, other than to the Work itself, because of injury to or destruction of tangible property wherever located, including loss of use resulting therefrom; and

6. claims for damages because of bodily injury or death of any person or property damage arising out of the ownership, maintenance or use of any motor vehicle.

B. The policies of insurance so required by this paragraph 5.04 to be purchased and maintained shall:

1. with respect to insurance required by paragraphs 5.04.A.3 through 5.04.A.6 inclusive, include as additional insureds (subject to any customary exclusion in respect of professional liability) OWNER, ENGINEER, ENGINEER's Consultants, and any other individuals or entities identified in the Supplementary Conditions, all of whom shall be listed as additional insureds, and include coverage for the respective officers, directors, partners, employees, agents, and other consultants and subcontractors of each and any of all such additional insureds, and the insurance afforded to these additional insureds shall provide primary coverage for all claims covered thereby;

2. include at least the specific coverages and be written for not less than the limits of liability provided in the Supplementary Conditions or required by Laws or Regulations, whichever is greater;

3. include completed operations insurance;

4. include contractual liability insurance covering CONTRACTOR's indemnity obligations under paragraphs 6.07, 6.11, and 6.20;

5. contain a provision or endorsement that the coverage afforded will not be canceled, materially changed or renewal refused until at least thirty days prior written notice has been given to OWNER and CONTRACTOR and to

each other additional insured identified in the Supplementary Conditions to whom a certificate of insurance has been issued (and the certificates of insurance furnished by the CONTRACTOR pursuant to paragraph 5.03 will so provide);

6. remain in effect at least until final payment and at all times thereafter when CONTRACTOR may be correcting, removing, or replacing defective Work in accordance with paragraph 13.07; and

7. with respect to completed operations insurance, and any insurance coverage written on a claims-made basis, remain in effect for at least two years after final payment (and CONTRACTOR shall furnish OWNER and each other additional insured identified in the Supplementary Conditions, to whom a certificate of insurance has been issued, evidence satisfactory to OWNER and any such additional insured of continuation of such insurance at final payment and one year thereafter).

5.05 OWNER's Liability Insurance

~~—A. In addition to the insurance required to be provided by CONTRACTOR under paragraph 5.04, OWNER, at OWNER's option, may purchase and maintain at OWNER's expense OWNER's own liability insurance as will protect OWNER against claims which may arise from operations under the Contract Documents.~~

5.06 Property Insurance

~~A. Unless otherwise provided in the Supplementary Conditions, OWNER shall purchase and maintain property insurance upon the Work at the Site in the amount of the full replacement cost thereof (subject to such deductible amounts as may be provided in the Supplementary Conditions or required by Laws and Regulations). This insurance shall:~~

~~1. include the interests of OWNER, CONTRACTOR, Subcontractors, ENGINEER, ENGINEER's Consultants, and any other individuals or entities identified in the Supplementary Conditions, and the officers, directors, partners, employees, agents, and other consultants and subcontractors of each and any of them, each of whom is deemed to have an insurable interest and shall be listed as an additional insured;~~

~~2. be written on a Builder's Risk "all-risk" or open peril or special causes of loss policy form that shall at least include insurance for physical loss or damage to the Work, temporary buildings, false work, and materials and~~

General Conditions - 00700 - 11

~~equipment in transit, and shall insure against at least the following perils or causes of loss: fire, lightning, extended coverage, theft, vandalism and malicious mischief, earthquake, collapse, debris removal, demolition occasioned by enforcement of Laws and Regulations, water damage, and such other perils or causes of loss as may be specifically required by the Supplementary Conditions;~~

~~3. include expenses incurred in the repair or replacement of any insured property (including but not limited to fees and charges of engineers and architects);~~

~~4. cover materials and equipment stored at the Site or at another location that was agreed to in writing by OWNER prior to being incorporated in the Work, provided that such materials and equipment have been included in an Application for Payment recommended by ENGINEER;~~

~~5. allow for partial utilization of the Work by OWNER;~~

~~6. include testing and startup; and~~

~~7. be maintained in effect until final payment is made unless otherwise agreed to in writing by OWNER, CONTRACTOR, and ENGINEER with 30 days written notice to each other additional insured to whom a certificate of insurance has been issued.~~

~~B. OWNER shall purchase and maintain such boiler and machinery insurance or additional property insurance as may be required by the Supplementary Conditions or Laws and Regulations which will include the interests of OWNER, CONTRACTOR, Subcontractors, ENGINEER, ENGINEER's Consultants, and any other individuals or entities identified in the Supplementary Conditions, each of whom is deemed to have an insurable interest and shall be listed as an insured or additional insured.~~

~~C. All the policies of insurance (and the certificates or other evidence thereof) required to be purchased and maintained in accordance with paragraph 5.06 will contain a provision or endorsement that the coverage afforded will not be canceled or materially changed or renewal refused until at least 30 days prior written notice has been given to OWNER and CONTRACTOR and to each other additional insured to whom a certificate of insurance has been issued and will contain waiver provisions in accordance with paragraph 5.07.~~

D. OWNER shall not be responsible for purchasing and maintaining any property insurance specified in this paragraph 5.06 to protect the interests of

CONTRACTOR, Subcontractors, or others in the Work to the extent of any deductible amounts that are identified in the Supplementary Conditions. The risk of loss within such identified deductible amount will be borne by CONTRACTOR, Subcontractors, or others suffering any such loss, and if any of them wishes property insurance coverage within the limits of such amounts, each may purchase and maintain it at the purchaser's own expense.

~~E. If CONTRACTOR requests in writing that other special insurance be included in the property insurance policies provided under paragraph 5.06, OWNER shall, if possible, include such insurance, and the cost thereof will be charged to CONTRACTOR by appropriate Change Order or Written Amendment. Prior to commencement of the Work at the Site, OWNER shall in writing advise CONTRACTOR whether or not such other insurance has been procured by OWNER.~~

5.07 Waiver of Rights

~~A. OWNER and CONTRACTOR intend that all policies purchased in accordance with paragraph 5.06 will protect OWNER, CONTRACTOR, Subcontractors, ENGINEER, ENGINEER's Consultants, and all other individuals or entities identified in the Supplementary Conditions to be listed as insureds or additional insureds (and the officers, directors, partners, employees, agents, and other consultants and subcontractors of each and any of them) in such policies and will provide primary coverage for all losses and damages caused by the perils or causes of loss covered thereby. All such policies shall contain provisions to the effect that in the event of payment of any loss or damage the insurers will have no rights of recovery against any of the insureds or additional insureds thereunder. OWNER and CONTRACTOR waive all rights against each other and their respective officers, directors, partners, employees, agents, and other consultants and subcontractors of each and any of them for all losses and damages caused by, arising out of or resulting from any of the perils or causes of loss covered by such policies and any other property insurance applicable to the Work; and, in addition, waive all such rights against Subcontractors, ENGINEER, ENGINEER's Consultants, and all other individuals or entities identified in the Supplementary Conditions to be listed as insureds or additional insureds (and the officers, directors, partners, employees, agents, and other consultants and subcontractors of each and any of them) under such policies for losses and damages so caused. None of the above waivers shall extend to the rights that any party making such waiver may have to the proceeds of insurance held by OWNER as trustee or otherwise payable under any policy so issued.~~

~~B. OWNER waives all rights against CONTRACTOR, Subcontractors, ENGINEER,~~
General Conditions - 00700 - 12

ENGINEER's Consultants, and the officers, directors, partners, employees, agents, and other consultants and subcontractors of each and any of them for:

1. ~~loss due to business interruption, loss of use, or other consequential loss extending beyond direct physical loss or damage to OWNER's property or the Work caused by, arising out of, or resulting from fire or other peril whether or not insured by OWNER; and~~

2. ~~loss or damage to the completed Project or part thereof caused by, arising out of, or resulting from fire or other insured peril or cause of loss covered by any property insurance maintained on the completed Project or part thereof by OWNER during partial utilization pursuant to paragraph 14.05, after Substantial Completion pursuant to paragraph 14.04, or after final payment pursuant to paragraph 14.07.~~

~~C. Any insurance policy maintained by OWNER covering any loss, damage or consequential loss referred to in paragraph 5.07.B shall contain provisions to the effect that in the event of payment of any such loss, damage, or consequential loss, the insurers will have no rights of recovery against CONTRACTOR, Subcontractors, ENGINEER, or ENGINEER's Consultants and the officers, directors, partners, employees, agents, and other consultants and subcontractors of each and any of them.~~

5.08 *Receipt and Application of Insurance Proceeds*

~~A. Any insured loss under the policies of insurance required by paragraph 5.06 will be adjusted with OWNER and made payable to OWNER as fiduciary for the insureds, as their interests may appear, subject to the requirements of any applicable mortgage clause and of paragraph 5.08.B. OWNER shall deposit in a separate account any money so received and shall distribute it in accordance with such agreement as the parties in interest may reach. If no other special agreement is reached, the damaged Work shall be repaired or replaced, the moneys so received applied on account thereof, and the Work and the cost thereof covered by an appropriate Change Order or Written Amendment.~~

~~B. OWNER as fiduciary shall have power to adjust and settle any loss with the insurers unless one of the parties in interest shall object in writing within 15 days after the occurrence of loss to OWNER's exercise of this power. If such objection be made, OWNER as fiduciary shall make settlement with the insurers in accordance with such agreement as the parties in interest may reach. If no such agreement among the parties in interest is reached, OWNER as fiduciary shall adjust and settle the loss with the insurers and, if required in writing by any party in interest, OWNER as~~

~~fiduciary shall give bond for the proper performance of such duties.~~

5.09 *Acceptance of Bonds and Insurance; Option to Replace*

~~A. If either OWNER or CONTRACTOR has any objection to the coverage afforded by or other provisions of the Bonds or insurance required to be purchased and maintained by the other party in accordance with Article 5 on the basis of non-conformance with the Contract Documents, the objecting party shall so notify the other party in writing within 10 days after receipt of the certificates (or other evidence requested) required by paragraph 2.05.C. OWNER and CONTRACTOR shall each provide to the other such additional information in respect of insurance provided as the other may reasonably request. If either party does not purchase or maintain all of the Bonds and insurance required of such party by the Contract Documents, such party shall notify the other party in writing of such failure to purchase prior to the start of the Work, or of such failure to maintain prior to any change in the required coverage. Without prejudice to any other right or remedy, the other party may elect to obtain equivalent Bonds or insurance to protect such other party's interests at the expense of the party who was required to provide such coverage, and a Change Order shall be issued to adjust the Contract Price accordingly.~~

5.10 *Partial Utilization, Acknowledgment of Property Insurer*

~~A. If OWNER finds it necessary to occupy or use a portion or portions of the Work prior to Substantial Completion of all the Work as provided in paragraph 14.05, no such use or occupancy shall commence before the insurers providing the property insurance pursuant to paragraph 5.06 have acknowledged notice thereof and in writing effected any changes in coverage necessitated thereby. The insurers providing the property insurance shall consent by endorsement on the policy or policies, but the property insurance shall not be canceled or permitted to lapse on account of any such partial use or occupancy.~~

ARTICLE 6 - CONTRACTOR'S RESPONSIBILITIES

6.01 *Supervision and Superintendence*

~~A. CONTRACTOR shall supervise, inspect, and direct the Work competently and efficiently, devoting such attention thereto and applying such skills and expertise as may be necessary to perform the Work in accordance with the Contract Documents. CONTRACTOR shall be solely responsible for the means, methods, techniques, sequences, and procedures of~~

construction, but CONTRACTOR shall not be responsible for the negligence of OWNER or ENGINEER in the design or specification of a specific means, method, technique, sequence, or procedure of construction which is shown or indicated in and expressly required by the Contract Documents. CONTRACTOR shall be responsible to see that the completed Work complies accurately with the Contract Documents.

B. At all times during the progress of the Work, CONTRACTOR shall assign a competent resident superintendent thereto who shall not be replaced without written notice to OWNER and ENGINEER except under extraordinary circumstances. The superintendent will be CONTRACTOR's representative at the Site and shall have authority to act on behalf of CONTRACTOR. All communications given to or received from the superintendent shall be binding on CONTRACTOR.

6.02 *Labor; Working Hours*

A. CONTRACTOR shall provide competent, suitably qualified personnel to survey, lay out, and construct the Work as required by the Contract Documents. CONTRACTOR shall at all times maintain good discipline and order at the Site.

B. Except as otherwise required for the safety or protection of persons or the Work or property at the Site or adjacent thereto, and except as otherwise stated in the Contract Documents, all Work at the Site shall be performed during regular working hours, and CONTRACTOR will not permit overtime work or the performance of Work on Saturday, Sunday, or any legal holiday without OWNER's written consent (which will not be unreasonably withheld) given after prior written notice to ENGINEER.

6.03 *Services, Materials, and Equipment*

A. Unless otherwise specified in the General Requirements, CONTRACTOR shall provide and assume full responsibility for all services, materials, equipment, labor, transportation, construction equipment and machinery, tools, appliances, fuel, power, light, heat, telephone, water, sanitary facilities, temporary facilities, and all other facilities and incidentals necessary for the performance, testing, start-up, and completion of the Work.

B. All materials and equipment incorporated into the Work shall be as specified or, if not specified, shall be of good quality and new, except as otherwise provided in the Contract Documents. All warranties and guarantees specifically called for by the Specifications shall expressly run to the benefit of OWNER. If required by ENGINEER, CONTRACTOR shall furnish satisfactory evidence (including reports of required tests) as to the source, kind, and quality of materials

and equipment. All materials and equipment shall be stored, applied, installed, connected, erected, protected, used, cleaned, and conditioned in accordance with instructions of the applicable Supplier, except as otherwise may be provided in the Contract Documents.

6.04 *Progress Schedule*

A. CONTRACTOR shall adhere to the progress schedule established in accordance with paragraph 2.07 as it may be adjusted from time to time as provided below.

1. CONTRACTOR shall submit to ENGINEER for acceptance (to the extent indicated in paragraph 2.07) proposed adjustments in the progress schedule that will not result in changing the Contract Times (or Milestones). Such adjustments will conform generally to the progress schedule then in effect and additionally will comply with any provisions of the General Requirements applicable thereto.

2. Proposed adjustments in the progress schedule that will change the Contract Times (or Milestones) shall be submitted in accordance with the requirements of Article 12. Such adjustments may only be made by a Change Order or Written Amendment in accordance with Article 12.

6.05 *Substitutes and "Or-Equals"*

A. Whenever an item of material or equipment is specified or described in the Contract Documents by using the name of a proprietary item or the name of a particular Supplier, the specification or description is intended to establish the type, function, appearance, and quality required. Unless the specification or description contains or is followed by words reading that no like, equivalent, or "or-equal" item or no substitution is permitted, other items of material or equipment or material or equipment of other Suppliers may be submitted to ENGINEER for review under the circumstances described below.

1. *"Or-Equal" Items:* If in ENGINEER's sole discretion an item of material or equipment proposed by CONTRACTOR is functionally equal to that named and sufficiently similar so that no change in related Work will be required, it may be considered by ENGINEER as an "or-equal" item, in which case review and approval of the proposed item may, in ENGINEER's sole discretion, be accomplished without compliance with some or all of the requirements for approval of proposed substitute items. For the purposes of this paragraph 6.05.A.1, a proposed item of material or

equipment will be considered functionally equal to an item so named if:

a. in the exercise of reasonable judgment ENGINEER determines that: (i) it is at least equal in quality, durability, appearance, strength, and design characteristics; (ii) it will reliably perform at least equally well the function imposed by the design concept of the completed Project as a functioning whole, and;

b. CONTRACTOR certifies that: (i) there is no increase in cost to the OWNER; and (ii) it will conform substantially, even with deviations, to the detailed requirements of the item named in the Contract Documents.

2. Substitute Items

a. If in ENGINEER's sole discretion an item of material or equipment proposed by CONTRACTOR does not qualify as an "or-equal" item under paragraph 6.05.A.1, it will be considered a proposed substitute item.

b. CONTRACTOR shall submit sufficient information as provided below to allow ENGINEER to determine that the item of material or equipment proposed is essentially equivalent to that named and an acceptable substitute therefor. Requests for review of proposed substitute items of material or equipment will not be accepted by ENGINEER from anyone other than CONTRACTOR.

c. The procedure for review by ENGINEER will be as set forth in paragraph 6.05.A.2.d, as supplemented in the General Requirements and as ENGINEER may decide is appropriate under the circumstances.

d. CONTRACTOR shall first make written application to ENGINEER for review of a proposed substitute item of material or equipment that CONTRACTOR seeks to furnish or use. The application shall certify that the proposed substitute item will perform adequately the functions and achieve the results called for by the general design, be similar in substance to that specified, and be suited to the same use as that specified. The application will state the extent, if any, to which the use of the proposed substitute item will prejudice CONTRACTOR's achievement of Substantial Completion on time, whether or not use of the proposed substitute item in the Work will require a

change in any of the Contract Documents (or in the provisions of any other direct contract with OWNER for work on the Project) to adapt the design to the proposed substitute item and whether or not incorporation or use of the proposed substitute item in connection with the Work is subject to payment of any license fee or royalty. All variations of the proposed substitute item from that specified will be identified in the application, and available engineering, sales, maintenance, repair, and replacement services will be indicated. The application will also contain an itemized estimate of all costs or credits that will result directly or indirectly from use of such substitute item, including costs of redesign and claims of other contractors affected by any resulting change, all of which will be considered by ENGINEER in evaluating the proposed substitute item. ENGINEER may require CONTRACTOR to furnish additional data about the proposed substitute item.

B. Substitute Construction Methods or Procedures: If a specific means, method, technique, sequence, or procedure of construction is shown or indicated in and expressly required by the Contract Documents, CONTRACTOR may furnish or utilize a substitute means, method, technique, sequence, or procedure of construction approved by ENGINEER. CONTRACTOR shall submit sufficient information to allow ENGINEER, in ENGINEER's sole discretion, to determine that the substitute proposed is equivalent to that expressly called for by the Contract Documents. The procedure for review by ENGINEER will be similar to that provided in subparagraph 6.05.A.2.

C. Engineer's Evaluation: ENGINEER will be allowed a reasonable time within which to evaluate each proposal or submittal made pursuant to paragraphs 6.05.A and 6.05.B. ENGINEER will be the sole judge of acceptability. No "or-equal" or substitute will be ordered, installed or utilized until ENGINEER's review is complete, which will be evidenced by either a Change Order for a substitute or an approved Shop Drawing for an "or equal." ENGINEER will advise CONTRACTOR in writing of any negative determination.

D. Special Guarantee: OWNER may require CONTRACTOR to furnish at CONTRACTOR's expense a special performance guarantee or other surety with respect to any substitute.

E. ENGINEER's Cost Reimbursement: ENGINEER will record time required by ENGINEER and ENGINEER's Consultants in evaluating substitute proposed or submitted by CONTRACTOR pursuant to paragraphs 6.05.A.2 and 6.05.B and in making changes in the Contract Documents (or in the

General Conditions - 00700 - 15

provisions of any other direct contract with OWNER for work on the Project) occasioned thereby. Whether or not ENGINEER approves a substitute item so proposed or submitted by CONTRACTOR, CONTRACTOR shall reimburse OWNER for the charges of ENGINEER and ENGINEER's Consultants for evaluating each such proposed substitute.

F. *CONTRACTOR's Expense*: CONTRACTOR shall provide all data in support of any proposed substitute or "or-equal" at CONTRACTOR's expense.

6.06 Concerning Subcontractors, Suppliers, and Others

A. CONTRACTOR shall not employ any Subcontractor, Supplier, or other individual or entity (including those acceptable to OWNER as indicated in paragraph 6.06.B), whether initially or as a replacement, against whom OWNER may have reasonable objection. CONTRACTOR shall not be required to employ any Subcontractor, Supplier, or other individual or entity to furnish or perform any of the Work against whom CONTRACTOR has reasonable objection.

B. If the Supplementary Conditions require the identity of certain Subcontractors, Suppliers, or other individuals or entities to be submitted to OWNER in advance for acceptance by OWNER by a specified date prior to the Effective Date of the Agreement, and if CONTRACTOR has submitted a list thereof in accordance with the Supplementary Conditions, OWNER's acceptance (either in writing or by failing to make written objection thereto by the date indicated for acceptance or objection in the Bidding Documents or the Contract Documents) of any such Subcontractor, Supplier, or other individual or entity so identified may be revoked on the basis of reasonable objection after due investigation. CONTRACTOR shall submit an acceptable replacement for the rejected Subcontractor, Supplier, or other individual or entity, and the Contract Price will be adjusted by the difference in the cost occasioned by such replacement, and an appropriate Change Order will be issued or Written Amendment signed. No acceptance by OWNER of any such Subcontractor, Supplier, or other individual or entity, whether initially or as a replacement, shall constitute a waiver of any right of OWNER or ENGINEER to reject defective Work.

C. CONTRACTOR shall be fully responsible to OWNER and ENGINEER for all acts and omissions of the Subcontractors, Suppliers, and other individuals or entities performing or furnishing any of the Work just as CONTRACTOR is responsible for CONTRACTOR's own acts and omissions. Nothing in the Contract Documents shall create for the benefit of any such Subcontractor, Supplier, or other individual or entity any contractual relationship between OWNER or ENGINEER and any such Subcontractor, Supplier or other individual or entity, nor shall it create any

obligation on the part of OWNER or ENGINEER to pay or to see to the payment of any moneys due any such Subcontractor, Supplier, or other individual or entity except as may otherwise be required by Laws and Regulations.

D. CONTRACTOR shall be solely responsible for scheduling and coordinating the Work of Subcontractors, Suppliers, and other individuals or entities performing or furnishing any of the Work under a direct or indirect contract with CONTRACTOR.

E. CONTRACTOR shall require all Subcontractors, Suppliers, and such other individuals or entities performing or furnishing any of the Work to communicate with ENGINEER through CONTRACTOR.

F. The divisions and sections of the Specifications and the identifications of any Drawings shall not control CONTRACTOR in dividing the Work among Subcontractors or Suppliers or delineating the Work to be performed by any specific trade.

G. All Work performed for CONTRACTOR by a Subcontractor or Supplier will be pursuant to an appropriate agreement between CONTRACTOR and the Subcontractor or Supplier which specifically binds the Subcontractor or Supplier to the applicable terms and conditions of the Contract Documents for the benefit of OWNER and ENGINEER. Whenever any such agreement is with a Subcontractor or Supplier who is listed as an additional insured on the property insurance provided in paragraph 5.06, the agreement between the CONTRACTOR and the Subcontractor or Supplier will contain provisions whereby the Subcontractor or Supplier waives all rights against OWNER, CONTRACTOR, ENGINEER, ENGINEER's Consultants, and all other individuals or entities identified in the Supplementary Conditions to be listed as insureds or additional insureds (and the officers, directors, partners, employees, agents, and other consultants and subcontractors of each and any of them) for all losses and damages caused by, arising out of, relating to, or resulting from any of the perils or causes of loss covered by such policies and any other property insurance applicable to the Work. If the insurers on any such policies require separate waiver forms to be signed by any Subcontractor or Supplier, CONTRACTOR will obtain the same.

6.07 *Patent Fees and Royalties*

A. CONTRACTOR shall pay all license fees and royalties and assume all costs incident to the use in the performance of the Work or the incorporation in the Work of any invention, design, process, product, or device which is the subject of patent rights or copyrights held by others. If a particular invention, design, process, product, or device is specified in the Contract Documents for use in the performance of the Work and if to the actual knowledge of OWNER or

General Conditions - 00700 - 16

ENGINEER its use is subject to patent rights or copyrights calling for the payment of any license fee or royalty to others, the existence of such rights shall be disclosed by OWNER in the Contract Documents. To the fullest extent permitted by Laws and Regulations, CONTRACTOR shall indemnify and hold harmless OWNER, ENGINEER, ENGINEER's Consultants, and the officers, directors, partners, employees or agents, and other consultants of each and any of them from and against all claims, costs, losses, and damages (including but not limited to all fees and charges of engineers, architects, attorneys, and other professionals and all court or arbitration or other dispute resolution costs) arising out of or relating to any infringement of patent rights or copyrights incident to the use in the performance of the Work or resulting from the incorporation in the Work of any invention, design, process, product, or device not specified in the Contract Documents.

6.08 *Permits*

A. Unless otherwise provided in the Supplementary Conditions, CONTRACTOR shall obtain and pay for all construction permits and licenses. OWNER shall assist CONTRACTOR, when necessary, in obtaining such permits and licenses. CONTRACTOR shall pay all governmental charges and inspection fees necessary for the prosecution of the Work which are applicable at the time of opening of Bids, or, if there are no Bids, on the Effective Date of the Agreement. CONTRACTOR shall pay all charges of utility owners for connections to the Work, and OWNER shall pay all charges of such utility owners for capital costs related thereto, such as plant investment fees.

6.09 *Laws and Regulations*

A. CONTRACTOR shall give all notices and comply with all Laws and Regulations applicable to the performance of the Work. Except where otherwise expressly required by applicable Laws and Regulations, neither OWNER nor ENGINEER shall be responsible for monitoring CONTRACTOR's compliance with any Laws or Regulations.

B. If CONTRACTOR performs any Work knowing or having reason to know that it is contrary to Laws or Regulations, CONTRACTOR shall bear all claims, costs, losses, and damages (including but not limited to all fees and charges of engineers, architects, attorneys, and other professionals and all court or arbitration or other dispute resolution costs) arising out of or relating to such Work; however, it shall not be CONTRACTOR's primary responsibility to make certain that the Specifications and Drawings are in accordance with Laws and Regulations, but this shall not relieve CONTRACTOR of CONTRACTOR's obligations under paragraph 3.03.

C. Changes in Laws or Regulations not known at the time of opening of Bids (or, on the Effective Date of the Agreement if there were no Bids) having an effect on the cost or time of performance of the Work may be the subject of an adjustment in Contract Price or Contract Times. If OWNER and CONTRACTOR are unable to agree on entitlement to or on the amount or extent, if any, of any such adjustment, a Claim may be made therefor as provided in paragraph 10.05.

6.10 *Taxes*

- A. CONTRACTOR shall pay all sales, consumer, use, and other similar taxes required to be paid by CONTRACTOR in accordance with the Laws and Regulations of the place of the Project which are applicable during the performance of the Work.
- B. OWNER qualifies for state and local sales tax exemption in the purchase of all material and equipment.

6.11 *Use of Site and Other Areas*

A. *Limitation on Use of Site and Other Areas*

1. CONTRACTOR shall confine construction equipment, the storage of materials and equipment, and the operations of workers to the Site and other areas permitted by Laws and Regulations, and shall not unreasonably encumber the Site and other areas with construction equipment or other materials or equipment. CONTRACTOR shall assume full responsibility for any damage to any such land or area, or to the owner or occupant thereof, or of any adjacent land or areas resulting from the performance of the Work.

2. Should any claim be made by any such owner or occupant because of the performance of the Work, CONTRACTOR shall promptly settle with such other party by negotiation or otherwise resolve the claim by arbitration or other dispute resolution proceeding or at law.

3. To the fullest extent permitted by Laws and Regulations, CONTRACTOR shall indemnify and hold harmless OWNER, ENGINEER, ENGINEER's Consultant, and the officers, directors, partners, employees, agents, and other consultants of each and any of them from and against all claims, costs, losses, and damages (including but not limited to all fees and charges of engineers, architects, attorneys, and other professionals and all court or arbitration or other dispute resolution costs) arising out of or relating to any claim or action, legal or equitable, brought by any such owner or

General Conditions - 00700 - 17

occupant against OWNER, ENGINEER, or any other party indemnified hereunder to the extent caused by or based upon CONTRACTOR's performance of the Work.

B. *Removal of Debris During Performance of the Work:* During the progress of the Work CONTRACTOR shall keep the Site and other areas free from accumulations of waste materials, rubbish, and other debris. Removal and disposal of such waste materials, rubbish, and other debris shall conform to applicable Laws and Regulations.

C. *Cleaning:* Prior to Substantial Completion of the Work CONTRACTOR shall clean the Site and make it ready for utilization by OWNER. At the completion of the Work CONTRACTOR shall remove from the Site all tools, appliances, construction equipment and machinery, and surplus materials and shall restore to original condition all property not designated for alteration by the Contract Documents.

D. *Loading Structures:* CONTRACTOR shall not load nor permit any part of any structure to be loaded in any manner that will endanger the structure, nor shall CONTRACTOR subject any part of the Work or adjacent property to stresses or pressures that will endanger it.

6.12 Record Documents

A. CONTRACTOR shall maintain in a safe place at the Site one record copy of all Drawings, Specifications, Addenda, Written Amendments, Change Orders, Work Change Directives, Field Orders, and written interpretations and clarifications in good order and annotated to show changes made during construction. These record documents together with all approved Samples and a counterpart of all approved Shop Drawings will be available to ENGINEER for reference. Upon completion of the Work, these record documents, Samples, and Shop Drawings will be delivered to ENGINEER for OWNER.

6.13 Safety and Protection

A. CONTRACTOR shall be solely responsible for initiating, maintaining and supervising all safety precautions and programs in connection with the Work. CONTRACTOR shall take all necessary precautions for the safety of, and shall provide the necessary protection to prevent damage, injury or loss to:

1. all persons on the Site or who may be affected by the Work;
2. all the Work and materials and equipment to be incorporated therein, whether in storage on or off the Site; and

3. other property at the Site or adjacent thereto, including trees, shrubs, lawns, walks, pavements, roadways, structures, utilities, and Underground Facilities not designated for removal, relocation, or replacement in the course of construction.

B. CONTRACTOR shall comply with all applicable Laws and Regulations relating to the safety of persons or property, or to the protection of persons or property from damage, injury, or loss; and shall erect and maintain all necessary safeguards for such safety and protection. CONTRACTOR shall notify owners of adjacent property and of Underground Facilities and other utility owners when prosecution of the Work may affect them, and shall cooperate with them in the protection, removal, relocation, and replacement of their property. All damage, injury, or loss to any property referred to in paragraph 6.13.A.2 or 6.13.A.3 caused, directly or indirectly, in whole or in part, by CONTRACTOR, any Subcontractor, Supplier, or any other individual or entity directly or indirectly employed by any of them to perform any of the Work, or anyone for whose acts any of them may be liable, shall be remedied by CONTRACTOR (except damage or loss attributable to the fault of Drawings or Specifications or to the acts or omissions of OWNER or ENGINEER or ENGINEER's Consultant, or anyone employed by any of them, or anyone for whose acts any of them may be liable, and not attributable, directly or indirectly, in whole or in part, to the fault or negligence of CONTRACTOR or any Subcontractor, Supplier, or other individual or entity directly or indirectly employed by any of them). CONTRACTOR's duties and responsibilities for safety and for protection of the Work shall continue until such time as all the Work is completed and ENGINEER has issued a notice to OWNER and CONTRACTOR in accordance with paragraph 14.07.B that the Work is acceptable (except as otherwise expressly provided in connection with Substantial Completion).

6.14 Safety Representative

A. CONTRACTOR shall designate a qualified and experienced safety representative at the Site whose duties and responsibilities shall be the prevention of accidents and the maintaining and supervising of safety precautions and programs.

6.15 Hazard Communication Programs

A. CONTRACTOR shall be responsible for coordinating any exchange of material safety data sheets or other hazard communication information required to be made available to or exchanged between or among employers at the Site in accordance with Laws or Regulations.

6.16 Emergencies

A. In emergencies affecting the safety or protection of persons or the Work or property at the Site or adjacent thereto, CONTRACTOR is obligated to act to prevent threatened damage, injury, or loss. CONTRACTOR shall give ENGINEER prompt written notice if CONTRACTOR believes that any significant changes in the Work or variations from the Contract Documents have been caused thereby or are required as a result thereof. If ENGINEER determines that a change in the Contract Documents is required because of the action taken by CONTRACTOR in response to such an emergency, a Work Change Directive or Change Order will be issued.

6.17 Shop Drawings and Samples

A. CONTRACTOR shall submit Shop Drawings to ENGINEER for review and approval in accordance with the acceptable schedule of Shop Drawings and Sample submittals. All submittals will be identified as ENGINEER may require and in the number of copies specified in the General Requirements. The data shown on the Shop Drawings will be complete with respect to quantities, dimensions, specified performance and design criteria, materials, and similar data to show ENGINEER the services, materials, and equipment CONTRACTOR proposes to provide and to enable ENGINEER to review the information for the limited purposes required by paragraph 6.17.E.

B. CONTRACTOR shall also submit Samples to ENGINEER for review and approval in accordance with the acceptable schedule of Shop Drawings and Sample submittals. Each Sample will be identified clearly as to material, Supplier, pertinent data such as catalog numbers, and the use for which intended and otherwise as ENGINEER may require to enable ENGINEER to review the submittal for the limited purposes required by paragraph 6.17.E. The numbers of each Sample to be submitted will be as specified in the Specifications.

C. Where a Shop Drawing or Sample is required by the Contract Documents or the schedule of Shop Drawings and Sample submittals acceptable to ENGINEER as required by paragraph 2.07, any related Work performed prior to ENGINEER's review and approval of the pertinent submittal will be at the sole expense and responsibility of CONTRACTOR.

D. Submittal Procedures

1. Before submitting each Shop Drawing or Sample, CONTRACTOR shall have determined and verified:

a. all field measurements, quantities, dimensions, specified performance criteria, installation requirements, materials, catalog

numbers, and similar information with respect thereto;

b. all materials with respect to intended use, fabrication, shipping, handling, storage, assembly, and installation pertaining to the performance of the Work;

c. all information relative to means, methods, techniques, sequences, and procedures of construction and safety precautions and programs incident thereto; and

d. CONTRACTOR shall also have reviewed and coordinated each Shop Drawing or Sample with other Shop Drawings and Samples and with the requirements of the Work and the Contract Documents.

2. Each submittal shall bear a stamp or specific written indication that CONTRACTOR has satisfied CONTRACTOR's obligations under the Contract Documents with respect to CONTRACTOR's review and approval of that submittal.

3. At the time of each submittal, CONTRACTOR shall give ENGINEER specific written notice of such variations, if any, that the Shop Drawing or Sample submitted may have from the requirements of the Contract Documents, such notice to be in a written communication separate from the submittal; and, in addition, shall cause a specific notation to be made on each Shop Drawing and Sample submitted to ENGINEER for review and approval of each such variation.

E. ENGINEER's Review

1. ENGINEER will timely review and approve Shop Drawings and Samples in accordance with the schedule of Shop Drawings and Sample submittals acceptable to ENGINEER. ENGINEER's review and approval will be only to determine if the items covered by the submittals will, after installation or incorporation in the Work, conform to the information given in the Contract Documents and be compatible with the design concept of the completed Project as a functioning whole as indicated by the Contract Documents.

2. ENGINEER's review and approval will not extend to means, methods, techniques, sequences, or procedures of construction (except where a particular means, method, technique, sequence, or procedure of construction is specifically and expressly called for

General Conditions - 00700 - 19

by the Contract Documents) or to safety precautions or programs incident thereto. The review and approval of a separate item as such will not indicate approval of the assembly in which the item functions.

3. ENGINEER's review and approval of Shop Drawings or Samples shall not relieve CONTRACTOR from responsibility for any variation from the requirements of the Contract Documents unless CONTRACTOR has in writing called ENGINEER's attention to each such variation at the time of each submittal as required by paragraph 6.17.D.3 and ENGINEER has given written approval of each such variation by specific written notation thereof incorporated in or accompanying the Shop Drawing or Sample approval; nor will any approval by ENGINEER relieve CONTRACTOR from responsibility for complying with the requirements of paragraph 6.17.D.1.

F. *Resubmittal Procedures*

1. CONTRACTOR shall make corrections required by ENGINEER and shall return the required number of corrected copies of Shop Drawings and submit as required new Samples for review and approval. CONTRACTOR shall direct specific attention in writing to revisions other than the corrections called for by ENGINEER on previous submittals.

6.18 *Continuing the Work*

A. CONTRACTOR shall carry on the Work and adhere to the progress schedule during all disputes or disagreements with OWNER. No Work shall be delayed or postponed pending resolution of any disputes or disagreements, except as permitted by paragraph 15.04 or as OWNER and CONTRACTOR may otherwise agree in writing.

6.19 *CONTRACTOR's General Warranty and Guarantee*

A. CONTRACTOR warrants and guarantees to OWNER, ENGINEER, and ENGINEER's Consultants that all Work will be in accordance with the Contract Documents and will not be defective. CONTRACTOR's warranty and guarantee hereunder excludes defects or damage caused by:

1. abuse, modification, or improper maintenance or operation by persons other than CONTRACTOR, Subcontractors, Suppliers, or any other individual or entity for whom CONTRACTOR is responsible; or
2. normal wear and tear under normal usage.

B. CONTRACTOR's obligation to perform and complete the Work in accordance with the Contract Documents shall be absolute. None of the following will constitute an acceptance of Work that is not in accordance with the Contract Documents or a release of CONTRACTOR's obligation to perform the Work in accordance with the Contract Documents:

1. observations by ENGINEER;
2. recommendation by ENGINEER or payment by OWNER of any progress or final payment;
3. the issuance of a certificate of Substantial Completion by ENGINEER or any payment related thereto by OWNER;
4. use or occupancy of the Work or any part thereof by OWNER;
5. any acceptance by OWNER or any failure to do so;
6. any review and approval of a Shop Drawing or Sample submittal or the issuance of a notice of acceptability by ENGINEER;
7. any inspection, test, or approval by others; or
8. any correction of defective Work by OWNER.

6.20 *Indemnification*

A. To the fullest extent permitted by Laws and Regulations, CONTRACTOR shall indemnify and hold harmless OWNER, ENGINEER, ENGINEER's Consultants, and the officers, directors, partners, employees, agents, and other consultants and subcontractors of each and any of them from and against all claims, costs, losses, and damages (including but not limited to all fees and charges of engineers, architects, attorneys, and other professionals and all court or arbitration or other dispute resolution costs) arising out of or relating to the performance of the Work, provided that any such claim, cost, loss, or damage:

1. is attributable to bodily injury, sickness, disease, or death, or to injury to or destruction of tangible property (other than the Work itself), including the loss of use resulting therefrom; and
 2. is caused in whole or in part by any negligent act or omission of CONTRACTOR, any Subcontractor, any Supplier, or any individual or entity directly or indirectly employed by any of them to perform any of the
- General Conditions - 00700 - 20

Work or anyone for whose acts any of them may be liable, regardless of whether or not caused in part by any negligence or omission of an individual or entity indemnified hereunder or whether liability is imposed upon such indemnified party by Laws and Regulations regardless of the negligence of any such individual or entity.

B. In any and all claims against OWNER or ENGINEER or any of their respective consultants, agents, officers, directors, partners, or employees by any employee (or the survivor or personal representative of such employee) of CONTRACTOR, any Subcontractor, any Supplier, or any individual or entity directly or indirectly employed by any of them to perform any of the Work, or anyone for whose acts any of them may be liable, the indemnification obligation under paragraph 6.20.A shall not be limited in any way by any limitation on the amount or type of damages, compensation, or benefits payable by or for CONTRACTOR or any such Subcontractor, Supplier, or other individual or entity under workers' compensation acts, disability benefit acts, or other employee benefit acts.

C. The indemnification obligations of CONTRACTOR under paragraph 6.20.A shall not extend to the liability of ENGINEER and ENGINEER's Consultants or to the officers, directors, partners, employees, agents, and other consultants and subcontractors of each and any of them arising out of:

1. the preparation or approval of, or the failure to prepare or approve, maps, Drawings, opinions, reports, surveys, Change Orders, designs, or Specifications; or
2. giving directions or instructions, or failing to give them, if that is the primary cause of the injury or damage.

ARTICLE 7 - OTHER WORK

7.01 *Related Work at Site*

A. OWNER may perform other work related to the Project at the Site by OWNER's employees, or let other direct contracts therefor, or have other work performed by utility owners. If such other work is not noted in the Contract Documents, then:

1. written notice thereof will be given to CONTRACTOR prior to starting any such other work; and
2. if OWNER and CONTRACTOR are unable to agree on entitlement to or on the

amount or extent, if any, of any adjustment in the Contract Price or Contract Times that should be allowed as a result of such other work, a Claim may be made therefor as provided in paragraph 10.05.

B. CONTRACTOR shall afford each other contractor who is a party to such a direct contract and each utility owner (and OWNER, if OWNER is performing the other work with OWNER's employees) proper and safe access to the Site and a reasonable opportunity for the introduction and storage of materials and equipment and the execution of such other work and shall properly coordinate the Work with theirs. Unless otherwise provided in the Contract Documents, CONTRACTOR shall do all cutting, fitting, and patching of the Work that may be required to properly connect or otherwise make its several parts come together and properly integrate with such other work. CONTRACTOR shall not endanger any work of others by cutting, excavating, or otherwise altering their work and will only cut or alter their work with the written consent of ENGINEER and the others whose work will be affected. The duties and responsibilities of CONTRACTOR under this paragraph are for the benefit of such utility owners and other contractors to the extent that there are comparable provisions for the benefit of CONTRACTOR in said direct contracts between OWNER and such utility owners and other contractors.

C. If the proper execution or results of any part of CONTRACTOR's Work depends upon work performed by others under this Article 7, CONTRACTOR shall inspect such other work and promptly report to ENGINEER in writing any delays, defects, or deficiencies in such other work that render it unavailable or unsuitable for the proper execution and results of CONTRACTOR's Work. CONTRACTOR's failure to so report will constitute an acceptance of such other work as fit and proper for integration with CONTRACTOR's Work except for latent defects and deficiencies in such other work.

7.02 *Coordination*

A. If OWNER intends to contract with others for the performance of other work on the Project at the Site, the following will be set forth in Supplementary Conditions:

1. the individual or entity who will have authority and responsibility for coordination of the activities among the various contractors will be identified;
2. the specific matters to be covered by such authority and responsibility will be itemized; and

3. the extent of such authority and responsibilities will be provided.

B. Unless otherwise provided in the Supplementary Conditions, OWNER shall have sole authority and responsibility for such coordination.

ARTICLE 8 - OWNER'S RESPONSIBILITIES

8.01 *Communications to Contractor*

A. Except as otherwise provided in these General Conditions, OWNER shall issue all communications to CONTRACTOR through ENGINEER.

8.02 *Replacement of ENGINEER*

A. In case of termination of the employment of ENGINEER, OWNER shall appoint an engineer to whom CONTRACTOR makes no reasonable objection, whose status under the Contract Documents shall be that of the former ENGINEER.

8.03 *Furnish Data*

A. OWNER shall promptly furnish the data required of OWNER under the Contract Documents.

8.04 *Pay Promptly When Due*

A. OWNER shall make payments to CONTRACTOR promptly when they are due as provided in paragraphs 14.02.C and 14.07.C.

8.05 *Lands and Easements; Reports and Tests*

A. OWNER's duties in respect of providing lands and easements and providing engineering surveys to establish reference points are set forth in paragraphs 4.01 and 4.05. Paragraph 4.02 refers to OWNER's identifying and making available to CONTRACTOR copies of reports of explorations and tests of subsurface conditions and drawings of physical conditions in or relating to existing surface or subsurface structures at or contiguous to the Site that have been utilized by ENGINEER in preparing the Contract Documents.

8.06 *Insurance*

A. OWNER's responsibilities, if any, in respect to purchasing and maintaining liability and property insurance are set forth in Article 5.

8.07 *Change Orders*

A. OWNER is obligated to execute Change Orders as indicated in paragraph 10.03.

8.08 *Inspections, Tests, and Approvals*

A. OWNER's responsibility in respect to certain inspections, tests, and approvals is set forth in paragraph 13.03.B.

8.09 *Limitations on OWNER's Responsibilities*

A. The OWNER shall not supervise, direct, or have control or authority over, nor be responsible for, CONTRACTOR's means, methods, techniques, sequences, or procedures of construction, or the safety precautions and programs incident thereto, or for any failure of CONTRACTOR to comply with Laws and Regulations applicable to the performance of the Work. OWNER will not be responsible for CONTRACTOR's failure to perform the Work in accordance with the Contract Documents.

8.10 *Undisclosed Hazardous Environmental Condition*

A. OWNER's responsibility in respect to an undisclosed Hazardous Environmental Condition is set forth in paragraph 4.06.

8.11 *Evidence of Financial Arrangements*

A. If and to the extent OWNER has agreed to furnish CONTRACTOR reasonable evidence that financial arrangements have been made to satisfy OWNER's obligations under the Contract Documents, OWNER's responsibility in respect thereof will be as set forth in the Supplementary Conditions.

ARTICLE 9 - ENGINEER'S STATUS DURING CONSTRUCTION

9.01 *OWNER'S Representative*

A. ENGINEER will be OWNER's representative during the construction period. The duties and responsibilities and the limitations of authority of ENGINEER as OWNER's representative during construction are set forth in the Contract Documents and will not be changed without written consent of OWNER and ENGINEER.

9.02 *Visits to Site*

A. ENGINEER will make visits to the Site at intervals appropriate to the various stages of construction as ENGINEER deems necessary in order to observe as an experienced and qualified design professional the progress that has been made and the quality of the various aspects of CONTRACTOR's executed Work. Based on information obtained during such visits and observations, ENGINEER, for the benefit of OWNER,

will determine, in general, if the Work is proceeding in accordance with the Contract Documents. ENGINEER will not be required to make exhaustive or continuous inspections on the Site to check the quality or quantity of the Work. ENGINEER's efforts will be directed toward providing for OWNER a greater degree of confidence that the completed Work will conform generally to the Contract Documents. On the basis of such visits and observations, ENGINEER will keep OWNER informed of the progress of the Work and will endeavor to guard OWNER against defective Work.

B. ENGINEER's visits and observations are subject to all the limitations on ENGINEER's authority and responsibility set forth in paragraph 9.10, and particularly, but without limitation, during or as a result of ENGINEER's visits or observations of CONTRACTOR's Work ENGINEER will not supervise, direct, control, or have authority over or be responsible for CONTRACTOR's means, methods, techniques, sequences, or procedures of construction, or the safety precautions and programs incident thereto, or for any failure of CONTRACTOR to comply with Laws and Regulations applicable to the performance of the Work.

9.03 *Project Representative*

A. If OWNER and ENGINEER agree, ENGINEER will furnish a Resident Project Representative to assist ENGINEER in providing more extensive observation of the Work. The responsibilities and authority and limitations thereon of any such Resident Project Representative and assistants will be as provided in paragraph 9.10 and in the Supplementary Conditions. If OWNER designates another representative or agent to represent OWNER at the Site who is not ENGINEER's Consultant, agent or employee, the responsibilities and authority and limitations thereon of such other individual or entity will be as provided in the Supplementary Conditions.

9.04 *Clarifications and Interpretations*

A. ENGINEER will issue with reasonable promptness such written clarifications or interpretations of the requirements of the Contract Documents as ENGINEER may determine necessary, which shall be consistent with the intent of and reasonably inferable from the Contract Documents. Such written clarifications and interpretations will be binding on OWNER and CONTRACTOR. If OWNER and CONTRACTOR are unable to agree on entitlement to or on the amount or extent, if any, of any adjustment in the Contract Price or Contract Times, or both, that should be allowed as a result of a written clarification or interpretation, a Claim may be made therefor as provided in paragraph 10.05.

9.05 *Authorized Variations in Work*

A. ENGINEER may authorize minor variations in the Work from the requirements of the Contract Documents which do not involve an adjustment in the Contract Price or the Contract Times and are compatible with the design concept of the completed Project as a functioning whole as indicated by the Contract Documents. ~~These may be accomplished by a Field Order and will be binding on OWNER and also on CONTRACTOR, who shall perform the Work involved promptly. If OWNER and CONTRACTOR are unable to agree on entitlement to or on the amount or extent, if any, of any adjustment in the Contract Price or Contract Times, or both, as a result of a Field Order, a Claim may be made therefor as provided in paragraph 10.05.~~

9.06 *Rejecting Defective Work*

A. ENGINEER will have authority to disapprove or reject Work which ENGINEER believes to be defective, or that ENGINEER believes will not produce a completed Project that conforms to the Contract Documents or that will prejudice the integrity of the design concept of the completed Project as a functioning whole as indicated by the Contract Documents. ENGINEER will also have authority to require special inspection or testing of the Work as provided in paragraph 13.04, whether or not the Work is fabricated, installed, or completed.

9.07 *Shop Drawings, Change Orders and Payments*

A. In connection with ENGINEER's authority as to Shop Drawings and Samples, see paragraph 6.17.

B. In connection with ENGINEER's authority as to Change Orders, see Articles 10, 11, and 12.

C. In connection with ENGINEER's authority as to Applications for Payment, see Article 14.

9.08 *Determinations for Unit Price Work*

A. ENGINEER will determine the actual quantities and classifications of Unit Price Work performed by CONTRACTOR. ENGINEER will review with CONTRACTOR the ENGINEER's preliminary determinations on such matters before rendering a written decision thereon (by recommendation of an Application for Payment or otherwise). ENGINEER's written decision thereon will be final and binding (except as modified by ENGINEER to reflect changed factual conditions or more accurate data) upon OWNER and CONTRACTOR, subject to the provisions of paragraph 10.05.

9.09 *Decisions on Requirements of Contract Documents and Acceptability of Work*

A. ENGINEER will be the initial interpreter of the requirements of the Contract Documents and judge of

the acceptability of the Work thereunder. Claims, disputes and other matters relating to the acceptability of the Work, the quantities and classifications of Unit Price Work, the interpretation of the requirements of the Contract Documents pertaining to the performance of the Work, and Claims seeking changes in the Contract Price or Contract Times will be referred initially to ENGINEER in writing, in accordance with the provisions of paragraph 10.05, with a request for a formal decision.

B. When functioning as interpreter and judge under this paragraph 9.09, ENGINEER will not show partiality to OWNER or CONTRACTOR and will not be liable in connection with any interpretation or decision rendered in good faith in such capacity. The rendering of a decision by ENGINEER pursuant to this paragraph 9.09 with respect to any such Claim, dispute, or other matter (except any which have been waived by the making or acceptance of final payment as provided in paragraph 14.07) will be a condition precedent to any exercise by OWNER or CONTRACTOR of such rights or remedies as either may otherwise have under the Contract Documents or by Laws or Regulations in respect of any such Claim, dispute, or other matter.

9.10 *Limitations on ENGINEER's Authority and Responsibilities*

A. Neither ENGINEER's authority or responsibility under this Article 9 or under any other provision of the Contract Documents nor any decision made by ENGINEER in good faith either to exercise or not exercise such authority or responsibility or the undertaking, exercise, or performance of any authority or responsibility by ENGINEER shall create, impose, or give rise to any duty in contract, tort, or otherwise owed by ENGINEER to CONTRACTOR, any Subcontractor, any Supplier, any other individual or entity, or to any surety for or employee or agent of any of them.

B. ENGINEER will not supervise, direct, control, or have authority over or be responsible for CONTRACTOR's means, methods, techniques, sequences, or procedures of construction, or the safety precautions and programs incident thereto, or for any failure of CONTRACTOR to comply with Laws and Regulations applicable to the performance of the Work. ENGINEER will not be responsible for CONTRACTOR's failure to perform the Work in accordance with the Contract Documents.

C. ENGINEER will not be responsible for the acts or omissions of CONTRACTOR or of any Subcontractor, any Supplier, or of any other individual or entity performing any of the Work.

D. ENGINEER's review of the final Application for Payment and accompanying documentation and all maintenance and operating instructions, schedules, guarantees, Bonds, certificates of inspection, tests and

approvals, and other documentation required to be delivered by paragraph 14.07.A will only be to determine generally that their content complies with the requirements of, and in the case of certificates of inspections, tests, and approvals that the results certified indicate compliance with, the Contract Documents.

E. The limitations upon authority and responsibility set forth in this paragraph 9.10 shall also apply to ENGINEER's Consultants, Resident Project Representative, and assistants.

ARTICLE 10 - CHANGES IN THE WORK; CLAIMS

10.01 *Authorized Changes in the Work*

A. Without invalidating the Agreement and without notice to any surety, OWNER may, at any time or from time to time, order additions, deletions, or revisions in the Work by a Written Amendment, a Change Order, or a Work Change Directive. Upon receipt of any such document, CONTRACTOR shall promptly proceed with the Work involved which will be performed under the applicable conditions of the Contract Documents (except as otherwise specifically provided).

B. If OWNER and CONTRACTOR are unable to agree on entitlement to, or on the amount or extent, if any, of an adjustment in the Contract Price or Contract Times, or both, that should be allowed as a result of a Work Change Directive, a Claim may be made therefor as provided in paragraph 10.05.

10.02 *Unauthorized Changes in the Work*

A. CONTRACTOR shall not be entitled to an increase in the Contract Price or an extension of the Contract Times with respect to any work performed that is not required by the Contract Documents as amended, modified, or supplemented as provided in paragraph 3.04, except in the case of an emergency as provided in paragraph 6.16 or in the case of uncovering Work as provided in paragraph 13.04.B.

10.03 *Execution of Change Orders*

A. OWNER and CONTRACTOR shall execute appropriate Change Orders recommended by ENGINEER (or Written Amendments) covering:

1. changes in the Work which are: (i) ordered by OWNER pursuant to paragraph 10.01.A, (ii) required because of acceptance of defective Work under paragraph 13.08.A or OWNER's correction of defective Work under paragraph 13.09, or (iii) agreed to by the parties;

2. changes in the Contract Price or Contract Times which are agreed to by the parties, including any undisputed sum or amount of time for Work actually performed in accordance with a Work Change Directive; and

3. changes in the Contract Price or Contract Times which embody the substance of any written decision rendered by ENGINEER pursuant to paragraph 10.05; provided that, in lieu of executing any such Change Order, an appeal may be taken from any such decision in accordance with the provisions of the Contract Documents and applicable Laws and Regulations, but during any such appeal, CONTRACTOR shall carry on the Work and adhere to the progress schedule as provided in paragraph 6.18.A.

10.04 *Notification to Surety*

A. If notice of any change affecting the general scope of the Work or the provisions of the Contract Documents (including, but not limited to, Contract Price or Contract Times) is required by the provisions of any Bond to be given to a surety, the giving of any such notice will be CONTRACTOR's responsibility. The amount of each applicable Bond will be adjusted to reflect the effect of any such change.

10.05 *Claims and Disputes*

A. *Notice:* Written notice stating the general nature of each Claim, dispute, or other matter shall be delivered by the claimant to ENGINEER and the other party to the Contract promptly (but in no event later than 30 days) after the start of the event giving rise thereto. Notice of the amount or extent of the Claim, dispute, or other matter with supporting data shall be delivered to the ENGINEER and the other party to the Contract within 60 days after the start of such event (unless ENGINEER allows additional time for claimant to submit additional or more accurate data in support of such Claim, dispute, or other matter). A Claim for an adjustment in Contract Price shall be prepared in accordance with the provisions of paragraph 12.01.B. A Claim for an adjustment in Contract Time shall be prepared in accordance with the provisions of paragraph 12.02.B. Each Claim shall be accompanied by claimant's written statement that the adjustment claimed is the entire adjustment to which the claimant believes it is entitled as a result of said event. The opposing party shall submit any response to ENGINEER and the claimant within 30 days after receipt of the claimant's last submittal (unless ENGINEER allows additional time).

B. *ENGINEER's Decision:* ENGINEER will render a formal decision in writing within 30 days after receipt of the last submittal of the claimant or the last submittal of the opposing party, if any. ENGINEER's

written decision on such Claim, dispute, or other matter will be final and binding upon OWNER and CONTRACTOR unless:

1. an appeal from ENGINEER's decision is taken within the time limits and in accordance with the dispute resolution procedures set forth in Article 16; or

2. if no such dispute resolution procedures have been set forth in Article 16, a written notice of intention to appeal from ENGINEER's written decision is delivered by OWNER or CONTRACTOR to the other and to ENGINEER within 30 days after the date of such decision, and a formal proceeding is instituted by the appealing party in a forum of competent jurisdiction within 60 days after the date of such decision or within 60 days after Substantial Completion, whichever is later (unless otherwise agreed in writing by OWNER and CONTRACTOR), to exercise such rights or remedies as the appealing party may have with respect to such Claim, dispute, or other matter in accordance with applicable Laws and Regulations.

C. If ENGINEER does not render a formal decision in writing within the time stated in paragraph 10.05.B, a decision denying the Claim in its entirety shall be deemed to have been issued 31 days after receipt of the last submittal of the claimant or the last submittal of the opposing party, if any.

D. No Claim for an adjustment in Contract Price or Contract Times (or Milestones) will be valid if not submitted in accordance with this paragraph 10.05.

ARTICLE 11 - COST OF THE WORK; CASH ALLOWANCES; UNIT PRICE WORK

11.01 *Cost of the Work*

A. *Costs Included:* The term Cost of the Work means the sum of all costs necessarily incurred and paid by CONTRACTOR in the proper performance of the Work. When the value of any Work covered by a Change Order or when a Claim for an adjustment in Contract Price is determined on the basis of Cost of the Work, the costs to be reimbursed to CONTRACTOR will be only those additional or incremental costs required because of the change in the Work or because of the event giving rise to the Claim. Except as otherwise may be agreed to in writing by OWNER, such costs shall be in amounts no higher than those prevailing in the locality of the Project, shall include only the following items, and shall not include any of the costs itemized in paragraph 11.01.B.

~~1. Payroll costs for employees in the direct employ of CONTRACTOR in the performance of the Work under schedules of job classifications agreed upon by OWNER and CONTRACTOR. Such employees shall include without limitation superintendents, foremen, and other personnel employed full time at the Site. Payroll costs for employees not employed full time on the Work shall be apportioned on the basis of their time spent on the Work. Payroll costs shall include, but not be limited to, salaries and wages plus the cost of fringe benefits, which shall include social security contributions, unemployment, excise, and payroll taxes, workers' compensation, health and retirement benefits, bonuses, sick leave, vacation and holiday pay applicable thereto. The expenses of performing Work outside of regular working hours, on Saturday, Sunday, or legal holidays, shall be included in the above to the extent authorized by OWNER.~~

2. Cost of all materials and equipment furnished and incorporated in the Work, including costs of transportation and storage thereof, and Suppliers' field services required in connection therewith. All cash discounts shall accrue to CONTRACTOR unless OWNER deposits funds with CONTRACTOR with which to make payments, in which case the cash discounts shall accrue to OWNER. All trade discounts, rebates and refunds and returns from sale of surplus materials and equipment shall accrue to OWNER, and CONTRACTOR shall make provisions so that they may be obtained.

3. Payments made by CONTRACTOR to Subcontractors for Work performed by Subcontractors. If required by OWNER, CONTRACTOR shall obtain competitive bids from subcontractors acceptable to OWNER and CONTRACTOR and shall deliver such bids to OWNER, who will then determine, with the advice of ENGINEER, which bids, if any, will be acceptable. If any subcontract provides that the Subcontractor is to be paid on the basis of Cost of the Work plus a fee, the Subcontractor's Cost of the Work and fee shall be determined in the same manner as CONTRACTOR's Cost of the Work and fee as provided in this paragraph 11.01.

4. Costs of special consultants (including but not limited to engineers, architects, testing laboratories, surveyors, attorneys, and accountants) employed for services specifically related to the Work.

5. Supplemental costs including the following:

a. The proportion of necessary transportation, travel, and subsistence expenses of CONTRACTOR's employees incurred in discharge of duties connected with the Work.

b. Cost, including transportation and maintenance, of all materials, supplies, equipment, machinery, appliances, office, and temporary facilities at the Site, and hand tools not owned by the workers, which are consumed in the performance of the Work, and cost, less market value, of such items used but not consumed which remain the property of CONTRACTOR.

c. Rentals of all construction equipment and machinery, and the parts thereof whether rented from CONTRACTOR or others in accordance with rental agreements approved by OWNER with the advice of ENGINEER, and the costs of transportation, loading, unloading, assembly, dismantling, and removal thereof. All such costs shall be in accordance with the terms of said rental agreements. The rental of any such equipment, machinery, or parts shall cease when the use thereof is no longer necessary for the Work.

d. Sales, consumer, use, and other similar taxes related to the Work, and for which CONTRACTOR is liable, imposed by Laws and Regulations.

e. Deposits lost for causes other than negligence of CONTRACTOR, any Subcontractor, or anyone directly or indirectly employed by any of them or for whose acts any of them may be liable, and royalty payments and fees for permits and licenses.

f. Losses and damages (and related expenses) caused by damage to the Work, not compensated by insurance or otherwise, sustained by CONTRACTOR in connection with the performance of the Work (except losses and damages within the deductible amounts of property insurance established in accordance with paragraph 5.06.D), provided such losses and damages have resulted from causes other than the negligence of CONTRACTOR, any Subcontractor, or anyone directly or indirectly employed by any of them or for whose acts any of them may be liable. Such losses shall include settlements made with the written consent and approval of OWNER. No such losses, damages, and expenses shall be included in the Cost of the Work for the purpose of determining CONTRACTOR's fee.

g. The cost of utilities, fuel, and sanitary facilities at the Site.

h. Minor expenses such as telegrams, long distance telephone calls, telephone service at the Site, expressage, and similar petty cash items in connection with the Work.

i. When the Cost of the Work is used to determine the value of a Change Order or of a Claim, the cost of premiums for additional Bonds and insurance required because of the changes in the Work or caused by the event giving rise to the Claim.

j. When all the Work is performed on the basis of cost-plus, the costs of premiums for all Bonds and insurance CONTRACTOR is required by the Contract Documents to purchase and maintain.

B. Costs Excluded: The term Cost of the Work shall not include any of the following items:

1. Payroll costs and other compensation of CONTRACTOR's officers, executives, principals (of partnerships and sole proprietorships), general managers, engineers, architects, estimators, attorneys, auditors, accountants, purchasing and contracting agents, expeditors, timekeepers, clerks, and other personnel employed by CONTRACTOR, whether at the Site or in CONTRACTOR's principal or branch office for general administration of the Work and not specifically included in the agreed upon schedule of job classifications referred to in paragraph 11.01.A.1 or specifically covered by paragraph 11.01.A.4, all of which are to be considered administrative costs covered by the CONTRACTOR's fee.

2. Expenses of CONTRACTOR's principal and branch offices other than CONTRACTOR's office at the Site.

3. Any part of CONTRACTOR's capital expenses, including interest on CONTRACTOR's capital employed for the Work and charges against CONTRACTOR for delinquent payments.

4. Costs due to the negligence of CONTRACTOR, any Subcontractor, or anyone directly or indirectly employed by any of them or for whose acts any of them may be liable, including but not limited to, the correction of defective Work, disposal of materials or equipment wrongly supplied, and making good any damage to property.

5. Other overhead or general expense costs of any kind and the costs of any item not specifically and expressly included in paragraphs 11.01.A and 11.01.B.

C. CONTRACTOR's Fee: When all the Work is performed on the basis of cost-plus, CONTRACTOR's fee shall be determined as set forth in the Agreement. When the value of any Work covered by a Change Order or when a Claim for an adjustment in Contract Price is determined on the basis of Cost of the Work, CONTRACTOR's fee shall be determined as set forth in paragraph 12.01.C.

D. Documentation: Whenever the Cost of the Work for any purpose is to be determined pursuant to paragraphs 11.01.A and 11.01.B, CONTRACTOR will establish and maintain records thereof in accordance with generally accepted accounting practices and submit in a form acceptable to ENGINEER an itemized cost breakdown together with supporting data.

11.02 Cash Allowances

A. It is understood that CONTRACTOR has included in the Contract Price all allowances so named in the Contract Documents and shall cause the Work so covered to be performed for such sums as may be acceptable to OWNER and ENGINEER. CONTRACTOR agrees that:

1. the allowances include the cost to CONTRACTOR (less any applicable trade discounts) of materials and equipment required by the allowances to be delivered at the Site, and all applicable taxes; and

2. CONTRACTOR's costs for unloading and handling on the Site, labor, installation costs, overhead, profit, and other expenses contemplated for the allowances have been included in the Contract Price and not in the allowances, and no demand for additional payment on account of any of the foregoing will be valid.

B. Prior to final payment, an appropriate Change Order will be issued as recommended by ENGINEER to reflect actual amounts due CONTRACTOR on account of Work covered by allowances, and the Contract Price shall be correspondingly adjusted.

11.03 Unit Price Work

A. Where the Contract Documents provide that all or part of the Work is to be Unit Price Work, initially the Contract Price will be deemed to include for all Unit Price Work an amount equal to the sum of the unit price for each separately identified item of Unit Price Work times the estimated quantity of each item as indicated in the Agreement. The estimated quantities of items of

General Conditions - 00700 - 27

Unit Price Work are not guaranteed and are solely for the purpose of comparison of Bids and determining an initial Contract Price. Determinations of the actual quantities and classifications of Unit Price Work performed by CONTRACTOR will be made by ENGINEER subject to the provisions of paragraph 9.08.

B. Each unit price will be deemed to include an amount considered by CONTRACTOR to be adequate to cover CONTRACTOR's overhead and profit for each separately identified item.

C. OWNER or CONTRACTOR may make a Claim for an adjustment in the Contract Price in accordance with paragraph 10.05 if:

1. the quantity of any item of Unit Price Work performed by CONTRACTOR differs materially and significantly from the estimated quantity of such item indicated in the Agreement; and
2. there is no corresponding adjustment with respect any other item of Work; and
3. if CONTRACTOR believes that CONTRACTOR is entitled to an increase in Contract Price as a result of having incurred additional expense or OWNER believes that OWNER is entitled to a decrease in Contract Price and the parties are unable to agree as to the amount of any such increase or decrease.

ARTICLE 12 - CHANGE OF CONTRACT PRICE; CHANGE OF CONTRACT TIMES

12.01 *Change of Contract Price*

A. The Contract Price may only be changed by a Change Order or by a Written Amendment. Any Claim for an adjustment in the Contract Price shall be based on written notice submitted by the party making the Claim to the ENGINEER and the other party to the Contract in accordance with the provisions of paragraph 10.05.

B. The value of any Work covered by a Change Order or of any Claim for an adjustment in the Contract Price will be determined as follows:

1. where the Work involved is covered by unit prices contained in the Contract Documents, by application of such unit prices to the quantities of the items involved (subject to the provisions of paragraph 11.03); or

2. where the Work involved is not covered by unit prices contained in the Contract Documents, by a mutually agreed lump sum (which may include an allowance for overhead and profit not necessarily in accordance with paragraph 12.01.C.2); or

3. where the Work involved is not covered by unit prices contained in the Contract Documents and agreement to a lump sum is not reached under paragraph 12.01.B.2, on the basis of the Cost of the Work (determined as provided in paragraph 11.01) plus a CONTRACTOR's fee for overhead and profit (determined as provided in paragraph 12.01.C).

C. *CONTRACTOR's Fee:* The CONTRACTOR's fee for overhead and profit shall be determined as follows:

1. a mutually acceptable fixed fee; or
2. if a fixed fee is not agreed upon, then a fee based on the following percentages of the various portions of the Cost of the Work:
 - a. for costs incurred under paragraphs 11.01.A.1 and 11.01.A.2, the CONTRACTOR's fee shall be 15 percent;
 - b. for costs incurred under paragraph 11.01.A.3, the CONTRACTOR's fee shall be five percent;
 - c. where one or more tiers of subcontracts are on the basis of Cost of the Work plus a fee and no fixed fee is agreed upon, the intent of paragraph 12.01.C.2.a is that the Subcontractor who actually performs the Work, at whatever tier, will be paid a fee of 15 percent of the costs incurred by such Subcontractor under paragraphs 11.01.A.1 and 11.01.A.2 and that any higher tier Subcontractor and CONTRACTOR will each be paid a fee of five percent of the amount paid to the next lower tier Subcontractor;
 - d. no fee shall be payable on the basis of costs itemized under paragraphs 11.01.A.4, 11.01.A.5, and 11.01.B;
 - e. the amount of credit to be allowed by CONTRACTOR to OWNER for any change which results in a net decrease in cost will be the amount of the actual net decrease in cost plus a deduction in CONTRACTOR's fee by an amount equal to five percent of such net decrease; and
 - f. when both additions and credits are involved in any one change, the adjustment

General Conditions - 00700 - 28

in CONTRACTOR's fee shall be computed on the basis of the net change in accordance with paragraphs 12.01.C.2.a through 12.01.C.2.e, inclusive.

12.02 *Change of Contract Times*

A. The Contract Times (or Milestones) may only be changed by a Change Order or by a Written Amendment. Any Claim for an adjustment in the Contract Times (or Milestones) shall be based on written notice submitted by the party making the claim to the ENGINEER and the other party to the Contract in accordance with the provisions of paragraph 10.05.

B. Any adjustment of the Contract Times (or Milestones) covered by a Change Order or of any Claim for an adjustment in the Contract Times (or Milestones) will be determined in accordance with the provisions of this Article 12.

12.03 *Delays Beyond CONTRACTOR's Control*

A. Where CONTRACTOR is prevented from completing any part of the Work within the Contract Times (or Milestones) due to delay beyond the control of CONTRACTOR, the Contract Times (or Milestones) will be extended in an amount equal to the time lost due to such delay if a Claim is made therefor as provided in paragraph 12.02.A. Delays beyond the control of CONTRACTOR shall include, but not be limited to, acts or neglect by OWNER, acts or neglect of utility owners or other contractors performing other work as contemplated by Article 7, fires, floods, epidemics, abnormal weather conditions, or acts of God.

12.04 *Delays Within CONTRACTOR's Control*

A. The Contract Times (or Milestones) will not be extended due to delays within the control of CONTRACTOR. Delays attributable to and within the control of a Subcontractor or Supplier shall be deemed to be delays within the control of CONTRACTOR.

12.05 *Delays Beyond OWNER's and CONTRACTOR's Control*

A. Where CONTRACTOR is prevented from completing any part of the Work within the Contract Times (or Milestones) due to delay beyond the control of both OWNER and CONTRACTOR, an extension of the Contract Times (or Milestones) in an amount equal to the time lost due to such delay shall be CONTRACTOR's sole and exclusive remedy for such delay.

12.06 *Delay Damages*

A. In no event shall OWNER or ENGINEER be liable to CONTRACTOR, any Subcontractor, any

Supplier, or any other person or organization, or to any surety for or employee or agent of any of them, for damages arising out of or resulting from:

1. delays caused by or within the control of CONTRACTOR; or

2. delays beyond the control of both OWNER and CONTRACTOR including but not limited to fires, floods, epidemics, abnormal weather conditions, acts of God, or acts or neglect by utility owners or other contractors performing other work as contemplated by Article 7.

B. Nothing in this paragraph 12.06 bars a change in Contract Price pursuant to this Article 12 to compensate CONTRACTOR due to delay, interference, or disruption directly attributable to actions or inactions of OWNER or anyone for whom OWNER is responsible.

ARTICLE 13 - TESTS AND INSPECTIONS; CORRECTION, REMOVAL OR ACCEPTANCE OF DEFECTIVE WORK

13.01 *Notice of Defects*

A. Prompt notice of all defective Work of which OWNER or ENGINEER has actual knowledge will be given to CONTRACTOR. All defective Work may be rejected, corrected, or accepted as provided in this Article 13.

13.02 *Access to Work*

A. OWNER, ENGINEER, ENGINEER's Consultants, other representatives and personnel of OWNER, independent testing laboratories, and governmental agencies with jurisdictional interests will have access to the Site and the Work at reasonable times for their observation, inspecting, and testing. CONTRACTOR shall provide them proper and safe conditions for such access and advise them of CONTRACTOR's Site safety procedures and programs so that they may comply therewith as applicable.

13.03 *Tests and Inspections*

A. CONTRACTOR shall give ENGINEER timely notice of readiness of the Work for all required inspections, tests, or approvals and shall cooperate with inspection and testing personnel to facilitate required inspections or tests.

~~B. OWNER shall employ and pay for the services of an independent testing laboratory to perform all~~

~~inspections, tests, or approvals required by the Contract Documents except:~~

~~1. for inspections, tests, or approvals covered by paragraphs 13.03.C and 13.03.D below;~~

~~2. that costs incurred in connection with tests or inspections conducted pursuant to paragraph 13.04.B shall be paid as provided in said paragraph 13.04.B; and~~

~~3. as otherwise specifically provided in the Contract Documents.~~

C. If Laws or Regulations of any public body having jurisdiction require any Work (or part thereof) specifically to be inspected, tested, or approved by an employee or other representative of such public body, CONTRACTOR shall assume full responsibility for arranging and obtaining such inspections, tests, or approvals, pay all costs in connection therewith, and furnish ENGINEER the required certificates of inspection or approval.

D. CONTRACTOR shall be responsible for arranging and obtaining and shall pay all costs in connection with any inspections, tests, or approvals required for OWNER's and ENGINEER's acceptance of materials or equipment to be incorporated in the Work; or acceptance of materials, mix designs, or equipment submitted for approval prior to CONTRACTOR's purchase thereof for incorporation in the Work. Such inspections, tests, or approvals shall be performed by organizations acceptable to OWNER and ENGINEER.

E. If any Work (or the work of others) that is to be inspected, tested, or approved is covered by CONTRACTOR without written concurrence of ENGINEER, it must, if requested by ENGINEER, be uncovered for observation.

F. Uncovering Work as provided in paragraph 13.03.E shall be at CONTRACTOR's expense unless CONTRACTOR has given ENGINEER timely notice of CONTRACTOR's intention to cover the same and ENGINEER has not acted with reasonable promptness in response to such notice.

13.04 *Uncovering Work*

A. If any Work is covered contrary to the written request of ENGINEER, it must, if requested by ENGINEER, be uncovered for ENGINEER's observation and replaced at CONTRACTOR's expense.

B. If ENGINEER considers it necessary or advisable that covered Work be observed by ENGINEER or inspected or tested by others, CONTRACTOR, at ENGINEER's request, shall uncover, expose,

or otherwise make available for observation, inspection, or testing as ENGINEER may require, that portion of the Work in question, furnishing all necessary labor, material, and equipment. If it is found that such Work is defective, CONTRACTOR shall pay all Claims, costs, losses, and damages (including but not limited to all fees and charges of engineers, architects, attorneys, and other professionals and all court or arbitration or other dispute resolution costs) arising out of or relating to such uncovering, exposure, observation, inspection, and testing, and of satisfactory replacement or reconstruction (including but not limited to all costs of repair or replacement of work of others); and OWNER shall be entitled to an appropriate decrease in the Contract Price. If the parties are unable to agree as to the amount thereof, OWNER may make a Claim therefor as provided in paragraph 10.05. If, however, such Work is not found to be defective, CONTRACTOR shall be allowed an increase in the Contract Price or an extension of the Contract Times (or Milestones), or both, directly attributable to such uncovering, exposure, observation, inspection, testing, replacement, and reconstruction. If the parties are unable to agree as to the amount or extent thereof, CONTRACTOR may make a Claim therefor as provided in paragraph 10.05.

13.05 *OWNER May Stop the Work*

~~A. If the Work is defective, or CONTRACTOR fails to supply sufficient skilled workers or suitable materials or equipment, or fails to perform the Work in such a way that the completed Work will conform to the Contract Documents, OWNER may order CONTRACTOR to stop the Work, or any portion thereof, until the cause for such order has been eliminated; however, this right of OWNER to stop the Work shall not give rise to any duty on the part of OWNER to exercise this right for the benefit of CONTRACTOR, any Subcontractor, any Supplier, any other individual or entity, or any surety for, or employee or agent of any of them.~~

13.06 *Correction or Removal of Defective Work*

A. CONTRACTOR shall correct all defective Work, whether or not fabricated, installed, or completed, or, if the Work has been rejected by ENGINEER, remove it from the Project and replace it with Work that is not defective. CONTRACTOR shall pay all Claims, costs, losses, and damages (including but not limited to all fees and charges of engineers, architects, attorneys, and other professionals and all court or arbitration or other dispute resolution costs) arising out of or relating to such correction or removal (including but not limited to all costs of repair or replacement of work of others).

13.07 *Correction Period*

~~A. If within one year after the date of Substantial Completion or such longer period of time as may be prescribed by Laws or Regulations or by the terms of any applicable special guarantee required by the Contract Documents or by any specific provision of the Contract Documents, any Work is found to be defective, or if the repair of any damages to the land or areas made available for CONTRACTOR's use by OWNER or permitted by Laws and Regulations as contemplated in paragraph 6.11.A is found to be defective, CONTRACTOR shall promptly, without cost to OWNER and in accordance with OWNER's written instructions: (i) repair such defective land or areas, or (ii) correct such defective Work or, if the defective Work has been rejected by OWNER, remove it from the Project and replace it with Work that is not defective, and (iii) satisfactorily correct or repair or remove and replace any damage to other Work, to the work of others or other land or areas resulting therefrom. If CONTRACTOR does not promptly comply with the terms of such instructions, or in an emergency where delay would cause serious risk of loss or damage, OWNER may have the defective Work corrected or repaired or may have the rejected Work removed and replaced, and all Claims, costs, losses, and damages (including but not limited to all fees and charges of engineers, architects, attorneys, and other professionals and all court or arbitration or other dispute resolution costs) arising out of or relating to such correction or repair or such removal and replacement (including but not limited to all costs of repair or replacement of work of others) will be paid by CONTRACTOR.~~

~~B. In special circumstances where a particular item of equipment is placed in continuous service before Substantial Completion of all the Work, the correction period for that item may start to run from an earlier date if so provided in the Specifications or by Written Amendment.~~

C. Where defective Work (and damage to other Work resulting therefrom) has been corrected or removed and replaced under this paragraph 13.07, the correction period hereunder with respect to such Work will be extended for an additional period of one year after such correction or removal and replacement has been satisfactorily completed.

D. CONTRACTOR's obligations under this paragraph 13.07 are in addition to any other obligation or warranty. The provisions of this paragraph 13.07 shall not be construed as a substitute for or a waiver of the provisions of any applicable statute of limitation or repose.

13.08 *Acceptance of Defective Work*

A. If, instead of requiring correction or removal and replacement of defective Work, OWNER (and, prior to ENGINEER's recommendation of final payment, ENGINEER) prefers to accept it, OWNER may do so. CONTRACTOR shall pay all Claims, costs, losses, and damages (including but not limited to all fees and charges of engineers, architects, attorneys, and other professionals and all court or arbitration or other dispute resolution costs) attributable to OWNER's evaluation of and determination to accept such defective Work (such costs to be approved by ENGINEER as to reasonableness) and the diminished value of the Work to the extent not otherwise paid by CONTRACTOR pursuant to this sentence. If any such acceptance occurs prior to ENGINEER's recommendation of final payment, a Change Order will be issued incorporating the necessary revisions in the Contract Documents with respect to the Work, and OWNER shall be entitled to an appropriate decrease in the Contract Price, reflecting the diminished value of Work so accepted. If the parties are unable to agree as to the amount thereof, OWNER may make a Claim therefor as provided in paragraph 10.05. If the acceptance occurs after such recommendation, an appropriate amount will be paid by CONTRACTOR to OWNER.

13.09 *OWNER May Correct Defective Work*

A. If CONTRACTOR fails within a reasonable time after written notice from ENGINEER to correct defective Work or to remove and replace rejected Work as required by ENGINEER in accordance with paragraph 13.06.A, or if CONTRACTOR fails to perform the Work in accordance with the Contract Documents, or if CONTRACTOR fails to comply with any other provision of the Contract Documents, OWNER may, after seven days written notice to CONTRACTOR, correct and remedy any such deficiency.

B. In exercising the rights and remedies under this paragraph, OWNER shall proceed expeditiously. In connection with such corrective and remedial action, OWNER may exclude CONTRACTOR from all or part of the Site, take possession of all or part of the Work and suspend CONTRACTOR's services related thereto, take possession of CONTRACTOR's tools, appliances, construction equipment and machinery at the Site, and incorporate in the Work all materials and equipment stored at the Site or for which OWNER has paid CONTRACTOR but which are stored elsewhere. CONTRACTOR shall allow OWNER, OWNER's representatives, agents and employees, OWNER's other contractors, and ENGINEER and ENGINEER's Consultants access to the Site to enable OWNER to exercise the rights and remedies under this paragraph.

C. All Claims, costs, losses, and damages (including but not limited to all fees and charges of engineers, architects, attorneys, and other professionals and all court or arbitration or other

General Conditions - 00700 - 31

dispute resolution costs) incurred or sustained by OWNER in exercising the rights and remedies under this paragraph 13.09 will be charged against CONTRACTOR, and a Change Order will be issued incorporating the necessary revisions in the Contract Documents with respect to the Work; and OWNER shall be entitled to an appropriate decrease in the Contract Price. If the parties are unable to agree as to the amount of the adjustment, OWNER may make a Claim therefor as provided in paragraph 10.05. Such claims, costs, losses and damages will include but not be limited to all costs of repair, or replacement of work of others destroyed or damaged by correction, removal, or replacement of CONTRACTOR's defective Work.

D. CONTRACTOR shall not be allowed an extension of the Contract Times (or Milestones) because of any delay in the performance of the Work attributable to the exercise by OWNER of OWNER's rights and remedies under this paragraph 13.09.

ARTICLE 14 - PAYMENTS TO CONTRACTOR AND COMPLETION

14.01 *Schedule of Values*

A. The schedule of values established as provided in paragraph 2.07.A will serve as the basis for progress payments and will be incorporated into a form of Application for Payment acceptable to ENGINEER. Progress payments on account of Unit Price Work will be based on the number of units completed.

14.02 *Progress Payments*

A. *Applications for Payments*

1. At least 20 days before the date established for each progress payment (but not more often than once a month), CONTRACTOR shall submit to ENGINEER for review an Application for Payment filled out and signed by CONTRACTOR covering the Work completed as of the date of the Application and accompanied by such supporting documentation as is required by the Contract Documents. If payment is requested on the basis of materials and equipment not incorporated in the Work but delivered and suitably stored at the Site or at another location agreed to in writing, the Application for Payment shall also be accompanied by a bill of sale, invoice, or other documentation warranting that OWNER has received the materials and equipment free and clear of all Liens and evidence that the materials and equipment are covered by appropriate property insurance or other

arrangements to protect OWNER's interest therein, all of which must be satisfactory to OWNER.

2. Beginning with the second Application for Payment, each Application shall include an affidavit of CONTRACTOR stating that all previous progress payments received on account of the Work have been applied on account to discharge CONTRACTOR's legitimate obligations associated with prior Applications for Payment.

3. The amount of retainage with respect to progress payments will be as stipulated in the Agreement.

B. *Review of Applications*

1. ENGINEER will, within 10 days after receipt of each Application for Payment, either indicate in writing a recommendation of payment and present the Application to OWNER or return the Application to CONTRACTOR indicating in writing ENGINEER's reasons for refusing to recommend payment. In the latter case, CONTRACTOR may make the necessary corrections and resubmit the Application.

2. ENGINEER's recommendation of any payment requested in an Application for Payment will constitute a representation by ENGINEER to OWNER, based on ENGINEER's observations on the Site of the executed Work as an experienced and qualified design professional and on ENGINEER's review of the Application for Payment and the accompanying data and schedules, that to the best of ENGINEER's knowledge, information and belief:

a. the Work has progressed to the point indicated;

b. the quality of the Work is generally in accordance with the Contract Documents (subject to an evaluation of the Work as a functioning whole prior to or upon Substantial Completion, to the results of any subsequent tests called for in the Contract Documents, to a final determination of quantities and classifications for Unit Price Work under paragraph 9.08, and to any other qualifications stated in the recommendation); and

c. The conditions precedent to CONTRACTOR's being entitled to such payment appear to have been fulfilled in so far

as it is ENGINEER's responsibility to observe the Work.

3. By recommending any such payment ENGINEER will not thereby be deemed to have represented that: (i) inspections made to check the quality or the quantity of the Work as it has been performed have been exhaustive, extended to every aspect of the Work in progress, or involved detailed inspections of the Work beyond the responsibilities specifically assigned to ENGINEER in the Contract Documents; or (ii) that there may not be other matters or issues between the parties that might entitle CONTRACTOR to be paid additionally by OWNER or entitle OWNER to withhold payment to CONTRACTOR.

4. Neither ENGINEER's review of CONTRACTOR's Work for the purposes of recommending payments nor ENGINEER's recommendation of any payment, including final payment, will impose responsibility on ENGINEER to supervise, direct, or control the Work or for the means, methods, techniques, sequences, or procedures of construction, or the safety precautions and programs incident thereto, or for CONTRACTOR's failure to comply with Laws and Regulations applicable to CONTRACTOR's performance of the Work. Additionally, said review or recommendation will not impose responsibility on ENGINEER to make any examination to ascertain how or for what purposes CONTRACTOR has used the moneys paid on account of the Contract Price, or to determine that title to any of the Work, materials, or equipment has passed to OWNER free and clear of any Liens.

5. ENGINEER may refuse to recommend the whole or any part of any payment if, in ENGINEER's opinion, it would be incorrect to make the representations to OWNER referred to in paragraph 14.02.B.2. ENGINEER may also refuse to recommend any such payment or, because of subsequently discovered evidence or the results of subsequent inspections or tests, revise or revoke any such payment recommendation previously made, to such extent as may be necessary in ENGINEER's opinion to protect OWNER from loss because:

a. the Work is defective, or completed Work has been damaged, requiring correction or replacement;

b. the Contract Price has been reduced by Written Amendment or Change Orders;

c. OWNER has been required to correct defective Work or complete Work in accordance with paragraph 13.09; or

~~d. ENGINEER has actual knowledge of the occurrence of any of the events enumerated in paragraph 15.02.A.~~

C. *Payment Becomes Due*

~~1. Ten days after presentation of the Application for Payment to OWNER with ENGINEER's recommendation, the amount recommended will (subject to the provisions of paragraph 14.02.D) become due, and when due will be paid by OWNER to CONTRACTOR.~~

D. *Reduction in Payment*

1. OWNER may refuse to make payment of the full amount recommended by ENGINEER because:

a. claims have been made against OWNER on account of CONTRACTOR's performance or furnishing of the Work;

b. Liens have been filed in connection with the Work, except where CONTRACTOR has delivered a specific Bond satisfactory to OWNER to secure the satisfaction and discharge of such Liens;

c. there are other items entitling OWNER to a set-off against the amount recommended; or

d. OWNER has actual knowledge of the occurrence of any of the events enumerated in paragraphs 14.02.B.5.a through 14.02.B.5.c or paragraph 15.02.A.

2. If OWNER refuses to make payment of the full amount recommended by ENGINEER, OWNER must give CONTRACTOR immediate written notice (with a copy to ENGINEER) stating the reasons for such action and promptly pay CONTRACTOR any amount remaining after deduction of the amount so withheld. OWNER shall promptly pay CONTRACTOR the amount so withheld, or any adjustment thereto agreed to by OWNER and CONTRACTOR, when CONTRACTOR corrects to OWNER's satisfaction the reasons for such action.

3. If it is subsequently determined that OWNER's refusal of payment was not justified, the amount wrongfully withheld shall be treated as an amount due as determined by paragraph 14.02.C.1.

14.03 *CONTRACTOR's Warranty of Title*

A. CONTRACTOR warrants and guarantees that title to all Work, materials, and equipment covered by any Application for Payment, whether incorporated in the Project or not, will pass to OWNER no later than the time of payment free and clear of all Liens.

14.04 *Substantial Completion*

A. When CONTRACTOR considers the entire Work ready for its intended use CONTRACTOR shall notify OWNER and ENGINEER in writing that the entire Work is substantially complete (except for items specifically listed by CONTRACTOR as incomplete) and request that ENGINEER issue a certificate of Substantial Completion. Promptly thereafter, OWNER, CONTRACTOR, and ENGINEER shall make an inspection of the Work to determine the status of completion. If ENGINEER does not consider the Work substantially complete, ENGINEER will notify CONTRACTOR in writing giving the reasons therefore. ~~If ENGINEER considers the Work substantially complete, ENGINEER will prepare and deliver to OWNER a tentative certificate of Substantial Completion which shall fix the date of Substantial Completion. There shall be attached to the certificate a tentative list of items to be completed or corrected before final payment. OWNER shall have seven days after receipt of the tentative certificate during which to make written objection to ENGINEER as to any provisions of the certificate or attached list. If, after considering such objections, ENGINEER concludes that the Work is not substantially complete, ENGINEER will within 14 days after submission of the tentative certificate to OWNER notify CONTRACTOR in writing, stating the reasons therefor. If, after consideration of OWNER's objections, ENGINEER considers the Work substantially complete, ENGINEER will within said 14 days execute and deliver to OWNER and CONTRACTOR a definitive certificate of Substantial Completion (with a revised tentative list of items to be completed or corrected) reflecting such changes from the tentative certificate as ENGINEER believes justified after consideration of any objections from OWNER. At the time of delivery of the tentative certificate of Substantial Completion ENGINEER will deliver to OWNER and CONTRACTOR a written recommendation as to division of responsibilities pending final payment between OWNER and CONTRACTOR with respect to security, operation, safety, and protection of the Work, maintenance, heat, utilities, insurance, and warranties and guarantees. Unless OWNER and CONTRACTOR agree otherwise in writing and so inform ENGINEER in writing prior to ENGINEER's issuing the definitive certificate of Substantial Completion, ENGINEER's aforesaid recommendation will be binding on OWNER and CONTRACTOR until final payment.~~

B. OWNER shall have the right to exclude CONTRACTOR from the Site after the date of

Substantial Completion, but OWNER shall allow CONTRACTOR reasonable access to complete or correct items on the tentative list.

14.05 *Partial Utilization*

A. Use by OWNER at OWNER's option of any substantially completed part of the Work which has specifically been identified in the Contract Documents, or which OWNER, ENGINEER, and CONTRACTOR agree constitutes a separately functioning and usable part of the Work that can be used by OWNER for its intended purpose without significant interference with CONTRACTOR's performance of the remainder of the Work, may be accomplished prior to Substantial Completion of all the Work subject to the following conditions.

1. OWNER at any time may request CONTRACTOR in writing to permit OWNER to use any such part of the Work which OWNER believes to be ready for its intended use and substantially complete. If CONTRACTOR agrees that such part of the Work is substantially complete, CONTRACTOR will certify to OWNER and ENGINEER that such part of the Work is substantially complete and request ENGINEER to issue a certificate of Substantial Completion for that part of the Work. CONTRACTOR at any time may notify OWNER and ENGINEER in writing that CONTRACTOR considers any such part of the Work ready for its intended use and substantially complete and request ENGINEER to issue a certificate of Substantial Completion for that part of the Work. Within a reasonable time after either such request, OWNER, CONTRACTOR, and ENGINEER shall make an inspection of that part of the Work to determine its status of completion. If ENGINEER does not consider that part of the Work to be substantially complete, ENGINEER will notify OWNER and CONTRACTOR in writing giving the reasons therefor. If ENGINEER considers that part of the Work to be substantially complete, the provisions of paragraph 14.04 will apply with respect to certification of Substantial Completion of that part of the Work and the division of responsibility in respect thereof and access thereto.

2. No occupancy or separate operation of part of the Work may occur prior to compliance with the requirements of paragraph 5.10 regarding property insurance.

14.06 *Final Inspection*

A. Upon written notice from CONTRACTOR that the entire Work or an agreed portion thereof is complete, ENGINEER will promptly make a final
General Conditions - 00700 - 34

inspection with OWNER and CONTRACTOR and will notify CONTRACTOR in writing of all particulars in which this inspection reveals that the Work is incomplete or defective. CONTRACTOR shall immediately take such measures as are necessary to complete such Work or remedy such deficiencies.

14.07 *Final Payment*

A. *Application for Payment*

1. After CONTRACTOR has, in the opinion of ENGINEER, satisfactorily completed all corrections identified during the final inspection and has delivered, in accordance with the Contract Documents, all maintenance and operating instructions, schedules, guarantees, Bonds, certificates or other evidence of insurance certificates of inspection, marked-up record documents (as provided in paragraph 6.12), and other documents, CONTRACTOR may make application for final payment following the procedure for progress payments.

2. The final Application for Payment shall be accompanied (except as previously delivered) by: (i) all documentation called for in the Contract Documents, including but not limited to the evidence of insurance required by subparagraph 5.04.B.7; (ii) consent of the surety, if any, to final payment; and (iii) complete and legally effective releases or waivers (satisfactory to OWNER) of all Lien rights arising out of or Liens filed in connection with the Work.

3. In lieu of the releases or waivers of Liens specified in paragraph 14.07.A.2 and as approved by OWNER, CONTRACTOR may furnish receipts or releases in full and an affidavit of CONTRACTOR that: (i) the releases and receipts include all labor, services, material, and equipment for which a Lien could be filed; and (ii) all payrolls, material and equipment bills, and other indebtedness connected with the Work for which OWNER or OWNER's property might in any way be responsible have been paid or otherwise satisfied. If any Subcontractor or Supplier fails to furnish such a release or receipt in full, CONTRACTOR may furnish a Bond or other collateral satisfactory to OWNER to indemnify OWNER against any Lien.

B. *Review of Application and Acceptance*

1. If, on the basis of ENGINEER's observation of the Work during construction and final inspection, and ENGINEER's review of the final Application for Payment and accompanying documentation as required by the Contract Documents, ENGINEER is satisfied that the Work has been completed and

CONTRACTOR's other obligations under the Contract Documents have been fulfilled, ENGINEER will, within ten days after receipt of the final Application for Payment, indicate in writing ENGINEER's recommendation of payment and present the Application for Payment to OWNER for payment. At the same time ENGINEER will also give written notice to OWNER and CONTRACTOR that the Work is acceptable subject to the provisions of paragraph 14.09. Otherwise, ENGINEER will return the Application for Payment to CONTRACTOR, indicating in writing the reasons for refusing to recommend final payment, in which case CONTRACTOR shall make the necessary corrections and resubmit the Application for Payment.

C. *Payment Becomes Due*

~~1. Thirty days after the presentation to OWNER of the Application for Payment and accompanying documentation, the amount recommended by ENGINEER will become due and, when due, will be paid by OWNER to CONTRACTOR.~~

14.08 *Final Completion Delayed*

A. If, through no fault of CONTRACTOR, final completion of the Work is significantly delayed, and if ENGINEER so confirms, OWNER shall, upon receipt of CONTRACTOR's final Application for Payment and recommendation of ENGINEER, and without terminating the Agreement, make payment of the balance due for that portion of the Work fully completed and accepted. If the remaining balance to be held by OWNER for Work not fully completed or corrected is less than the retainage stipulated in the Agreement, and if Bonds have been furnished as required in paragraph 5.01, the written consent of the surety to the payment of the balance due for that portion of the Work fully completed and accepted shall be submitted by CONTRACTOR to ENGINEER with the Application for such payment. Such payment shall be made under the terms and conditions governing final payment, except that it shall not constitute a waiver of Claims.

14.09 *Waiver of Claims*

A. The making and acceptance of final payment will constitute:

1. a waiver of all Claims by OWNER against CONTRACTOR, except Claims arising from unsettled Liens, from defective Work appearing after final inspection pursuant to paragraph 14.06, from failure to comply with the Contract Documents or the terms of any special guarantees specified therein, or from

CONTRACTOR's continuing obligations under the Contract Documents; and

2. a waiver of all Claims by CONTRACTOR against OWNER other than those previously made in writing which are still unsettled.

ARTICLE 15 - SUSPENSION OF WORK AND TERMINATION

15.01 OWNER May Suspend Work

A. At any time and without cause, OWNER may suspend the Work or any portion thereof for a period of not more than 90 consecutive days by notice in writing to CONTRACTOR and ENGINEER which will fix the date on which Work will be resumed. CONTRACTOR shall resume the Work on the date so fixed. ~~CONTRACTOR shall be allowed an adjustment in the Contract Price or an extension of the Contract Times, or both, directly attributable to any such suspension if CONTRACTOR makes a Claim therefor as provided in paragraph 10.05.~~

15.02 OWNER May Terminate for Cause

A. The occurrence of any one or more of the following events will justify termination for cause:

1. CONTRACTOR's persistent failure to perform the Work in accordance with the Contract Documents (including, but not limited to, failure to supply sufficient skilled workers or suitable materials or equipment or failure to adhere to the progress schedule established under paragraph 2.07 as adjusted from time to time pursuant to paragraph 6.04);

2. CONTRACTOR's disregard of Laws or Regulations of any public body having jurisdiction;

3. CONTRACTOR's disregard of the authority of ENGINEER; or

4. CONTRACTOR's violation in any substantial way of any provisions of the Contract Documents.

B. If one or more of the events identified in paragraph 15.02.A occur, OWNER may, after giving CONTRACTOR (and the surety, if any) seven days written notice, terminate the services of CONTRACTOR, exclude CONTRACTOR from the Site, and take possession of the Work and of all CONTRACTOR's tools, appliances, construction equipment, and machinery at the Site, and use the

same to the full extent they could be used by CONTRACTOR (without liability to CONTRACTOR for trespass or conversion), incorporate in the Work all materials and equipment stored at the Site or for which OWNER has paid CONTRACTOR but which are stored elsewhere, and finish the Work as OWNER may deem expedient. In such case, CONTRACTOR shall not be entitled to receive any further payment until the Work is finished. If the unpaid balance of the Contract Price exceeds all claims, costs, losses, and damages (including but not limited to all fees and charges of engineers, architects, attorneys, and other professionals and all court or arbitration or other dispute resolution costs) sustained by OWNER arising out of or relating to completing the Work, such excess will be paid to CONTRACTOR. If such claims, costs, losses, and damages exceed such unpaid balance, CONTRACTOR shall pay the difference to OWNER. Such claims, costs, losses, and damages incurred by OWNER will be reviewed by ENGINEER as to their reasonableness and, when so approved by ENGINEER, incorporated in a Change Order. When exercising any rights or remedies under this paragraph OWNER shall not be required to obtain the lowest price for the Work performed.

C. Where CONTRACTOR's services have been so terminated by OWNER, the termination will not affect any rights or remedies of OWNER against CONTRACTOR then existing or which may thereafter accrue. Any retention or payment of moneys due CONTRACTOR by OWNER will not release CONTRACTOR from liability.

15.03 OWNER May Terminate For Convenience

A. Upon seven days written notice to CONTRACTOR and ENGINEER, OWNER may, without cause and without prejudice to any other right or remedy of OWNER, elect to terminate the Contract. In such case, CONTRACTOR shall be paid (without duplication of any items):

1. for completed and acceptable Work executed in accordance with the Contract Documents prior to the effective date of termination, including fair and reasonable sums for overhead and profit on such Work;

2. for expenses sustained prior to the effective date of termination in performing services and furnishing labor, materials, or equipment as required by the Contract Documents in connection with uncompleted Work, plus fair and reasonable sums for overhead and profit on such expenses;

3. for all claims, costs, losses, and damages (including but not limited to all fees and charges of engineers, architects, attorneys, and other professionals and all court or

General Conditions - 00700 - 36

arbitration or other dispute resolution costs) incurred in settlement of terminated contracts with Subcontractors, Suppliers, and others; and

4. for reasonable expenses directly attributable to termination.

B. CONTRACTOR shall not be paid on account of loss of anticipated profits or revenue or other economic loss arising out of or resulting from such termination.

15.04 *CONTRACTOR May Stop Work or Terminate*

A. If, through no act or fault of CONTRACTOR, the Work is suspended for more than 90 consecutive days by OWNER or under an order of court or other public authority, or ENGINEER fails to act on any Application for Payment within 30 days after it is submitted, ~~or OWNER fails for 30 days to pay CONTRACTOR any sum finally determined to be due~~, then CONTRACTOR may, upon seven days written notice to OWNER and ENGINEER, and provided OWNER or ENGINEER do not remedy such suspension or failure within that time, terminate the Contract and recover from OWNER payment on the same terms as provided in paragraph 15.03. In lieu of terminating the Contract and without prejudice to any other right or remedy, if ENGINEER has failed to act on an Application for Payment within 30 days after it is submitted, ~~or OWNER has failed for 30 days to pay CONTRACTOR any sum finally determined to be due~~, CONTRACTOR may, seven days after written notice to OWNER and ENGINEER, stop the Work until payment is made of all such amounts due CONTRACTOR, including interest thereon. The provisions of this paragraph 15.04 are not intended to preclude CONTRACTOR from making a Claim under paragraph 10.05 for an adjustment in Contract Price or Contract Times or otherwise for expenses or damage directly attributable to CONTRACTOR's stopping the Work as permitted by this paragraph.

ARTICLE 16 - DISPUTE RESOLUTION

16.01 *Methods and Procedures*

A. Dispute resolution methods and procedures, if any, shall be as set forth in the Supplementary Conditions. If no method and procedure has been set forth, and subject to the provisions of paragraphs 9.09 and 10.05, OWNER and CONTRACTOR may exercise such rights or remedies as either may otherwise have under the Contract Documents or by Laws or Regulations in respect of any dispute.

ARTICLE 17 - MISCELLANEOUS

17.01 *Giving Notice*

A. Whenever any provision of the Contract Documents requires the giving of written notice, it will be deemed to have been validly given if delivered in person to the individual or to a member of the firm or to an officer of the corporation for whom it is intended, or if delivered at or sent by registered or certified mail, postage prepaid, to the last business address known to the giver of the notice.

17.02 *Computation of Times*

A. When any period of time is referred to in the Contract Documents by days, it will be computed to exclude the first and include the last day of such period. If the last day of any such period falls on a Saturday or Sunday or on a day made a legal holiday by the law of the applicable jurisdiction, such day will be omitted from the computation.

17.03 *Cumulative Remedies*

A. The duties and obligations imposed by these General Conditions and the rights and remedies available hereunder to the parties hereto are in addition to, and are not to be construed in any way as a limitation of, any rights and remedies available to any or all of them which are otherwise imposed or available by Laws or Regulations, by special warranty or guarantee, or by other provisions of the Contract Documents, and the provisions of this paragraph will be as effective as if repeated specifically in the Contract Documents in connection with each particular duty, obligation, right, and remedy to which they apply.

17.04 *Survival of Obligations*

A. All representations, indemnifications, warranties, and guarantees made in, required by, or given in accordance with the Contract Documents, as well as all continuing obligations indicated in the Contract Documents, will survive final payment, completion, and acceptance of the Work or termination or completion of the Agreement.

17.05 *Controlling Law*

A. This Contract is to be governed by the law of the state in which the Project is located.

**SECTION 00800 - SUPPLEMENTARY CONDITION TO THE
GENERAL CONDITIONS**

Table of Contents

<u>Article Title</u>	<u>Page Number</u>
SECTION 00800 - SUPPLEMENTARY CONDITION TO THE GENERAL CONDITIONS	1
Table Of Content.....	1
SECTION 00800 - SUPPLEMENTARY CONDITIONS TO THE GENERAL CONDITIONS	2
SC-1.00 Introduction	2
SC-1.01 Defined Terms.....	2
SC-1.02 Terminology	2
SC-2.05 Before Starting Construction	2
SC-2.06 Preconstruction Conference	2
SC-3.06 Coordination of Plans, Specifications, and Special Provisions	3
SC-4.02 Subsurface and Physical Conditions.....	4
SC-5.01 Performance, Payment and Other Bonds	4
SC-5.03 Certificates of Insurance	4
SC-5.04 CONTRACTOR’S Liability Insurance	4
SC-5.05 OWNER’S Liability Insurance	5
SC-5.06 Property Insurance.....	6
SC-5.07 Waiver of Rights	6
SC-5.08 Receipt and Application of Insurance Proceeds	6
SC-5.09 Acceptance of Bonds and Insurance; Option to Replace.....	6
SC-6.02 Labor; Working Hours	6
SC-6.06 Concerning Subcontractors, Suppliers, and Others	6
SC-6.08 Permits	7
SC-9.05 Authorized Variations in Work.....	7
SC-11.01 Cost of the Work	7
SC-13.03 Test and Inspections	7
SC-13.05 OWNER May Stop the Work	8
SC-13.07 Correction Period	8
SC-14.02 Progress Payments.....	8
SC-14.04 Substantial Completion.....	9
SC-14.07 Final Payment.....	10
SC-15.01 OWNER May Suspend Work	10
SC-15.02 OWNER May Terminate For Cause	10
SC-15.04 CONTRACTOR May Stop Work or Terminate	11
SC-16 Dispute Resolution	11
SC-16.02 Mediation.....	11
SC-17 Miscellaneous	12
SC-17.06 Liens	12

+++ END OF THIS SUPPLEMENTARY CONDITIONS INDEX +++

Supplementary Conditions – 00800-1

SECTION 00800 - SUPPLEMENTARY CONDITIONS TO THE GENERAL CONDITIONS

SC-1.00 Introduction

These Supplementary Conditions amend or supplement the Standard General Conditions of the Construction Contract (No. 1910-8, 1996 Edition) and other provisions of the Contract Documents as indicated below. All provisions, which are not so amended or supplemented, remain in full force and effect.

The terms used in these Supplementary Conditions will have the meanings indicated in the General Conditions.

SC-1.01 Defined Terms

SC-1.01.A.20 *Add the following language to the end of GC 1.01.A.20.*

ENGINEERS's Consultant:	MBV Engineering, Inc. 1835 20 th Street Vero Beach, FL 32960
-------------------------	---

SC-1.01.A.21. Delete paragraph GC 1.01.A.21 in its entirety.

SC-1.02 Terminology

SC-1.02.D.1, 2, and 3 *Delete paragraphs GC-1.02.D.1, 2, and 3 in their entirety and insert the following paragraphs in their place:*

D. *Furnish, Install, Perform, Provide*

1. The word "furnish" shall mean to supply and deliver services, materials, or equipment to the Site (or some other specified location) ready for use or installation and in usable or operable condition.
2. The word "install" shall mean to put into use or place in final position services, materials, or equipment complete and ready for intended use.
3. The words "perform" or "provide" shall mean to furnish and install services, materials, or equipment complete and ready for intended use.

SC-2.05 Before Starting Construction

SC-2.05.C. *Delete paragraph GC 2.05.C in its entirety and insert the following paragraph in its place:*

- C. Evidence of Insurance: CONTRACTOR shall not commence work under this Contract until he has obtained all insurance required under Article 5 and such insurance has been delivered to the OWNER and approved by the OWNER, nor shall the CONTRACTOR allow any Subcontractor to commence work on his subcontract until all similar insurance required of the Subcontractor has been so obtained and approved. All such insurance shall remain in effect until final payment and at all times thereafter when CONTRACTOR may be correcting, removing or replacing *defective* Work in accordance with Article 13.

SC-2.06 Preconstruction Conference

SC-2.06 *Delete paragraph GC-2.06.A in its entirety and insert the following paragraph in its place:*

Supplementary Conditions - 00800-2

- A. Immediately after awarding the contract, but before the CONTRACTOR begins work, the Project Manager will call a preconstruction conference at a place the ENGINEER designates to establish an understanding among the parties as to the work and to discuss schedules referred to in paragraph 2.05.B, procedures for handling Shop Drawings and other submittals, and maintaining required records. Utility companies and others as appropriate will be requested to attend to discuss and coordinate work.
- B. Per the FDOT Standard Specifications for Road and Bridge Construction, the Contractor will certify to the Engineer the following:
 - 1. A listing of on-site clerical staff, supervisory personnel and their pro-rated time assigned to the contract,
 - 2. Actual Rate for items listed in Table 4-3.2.1 (see below),
 - 3. Existence of employee benefit plan for Holiday, Sick and Vacation benefits and a Retirement Plan, and,
 - 4. Payment of Per Diem is a company practice for instances when compensation for Per Diem is requested.

Such certification must be made by an officer or director of the Contractor with authority to bind the Contractor. Timely certification is a condition precedent to any right of the Contractor to recover compensations for such costs, and failure to timely submit the certification will constitute a full, complete, absolute and irrevocable waiver by the Contractor of any right to recover such costs. Any subsequent changes shall be certified to the Engineer as part of the cost proposal or seven calendar days in advance of performing such extra work.

FDOT Table 4-3.2.1	
Item	Rate
FICA	Rate established by Law
FUTA/SUTA	Rate established by Law
Medical Insurance	Actual
Holidays, Sick & Vacation Benefits	Actual
Retirement Benefits	Actual
Workers Compensation	Rates based on the National Council on Compensation Insurance basic rates tables adjusted by Contractor's actual experience modification factor in effect at the time of the additional work or unforeseen work
Per Diem	Actual but not to exceed State of Florida's rate
Insurance*	Actual
*Compensation for Insurance is limited solely to General Liability Coverage and does not include any other insurance coverage (such as, but not limited to, Umbrella Coverage, Automobile Insurance, etc.).	

SC-3.06 Coordination of Plans, Specifications, and Special Provisions

SC-3.06 Add the following new paragraphs immediately after paragraph GC-3.05:

SC-3.06 Coordination of Plans, Specifications, and Special Provisions

- A. In case of discrepancy, the governing order of the documents shall be as follows:
 - 1. Written Interpretations
 - 2. Addenda
 - 3. Specifications
 - 4. Supplementary Conditions to the General Conditions
 - 5. General Conditions

6. Approved Shop Drawings
 7. Drawings
 8. Referenced Standards.
- B. Written/computed dimensions shall govern over scaled dimensions.

SC-4.02 Subsurface and Physical Conditions

SC-4.02 *Add the following new paragraphs immediately after paragraph GC-4.02.B:*

- C. In the preparation of Drawings and Specifications, ENGINEER or ENGINEER's Consultants relied upon the following reports of explorations and tests of subsurface conditions at the Site:
N/A

SC-5.01 Performance, Payment and Other Bonds

SC-5.01.A. *Delete paragraph GC-5.01.A in its entirety and insert the following paragraphs in its place:*

Within fifteen (15) days of receipt of the Contract Documents for execution, the CONTRACTOR shall furnish a Public Construction Bond in an amount equal to 100% of the Contract Price.

1. In lieu of the Public Construction Bond, the CONTRACTOR may furnish an alternative form of security in the form of cash, money order, certified check, cashier's check, irrevocable letter of credit or a security as listed in Part II of F.S. Chapter 625. Any such alternative form of security shall be for the same purpose, and be for the same amount and subject to the same conditions as those applicable to the bond otherwise required. The determination of the value of an alternative form of security shall be made by the OWNER.
2. Such Bond shall continue in effect for one (1) year after acceptance of the Work by the OWNER.
3. The OWNER shall record the Public Construction Bond with the Public Record Section of the Indian River County Courthouse located at 2000 16th Avenue, Vero Beach, Florida 32960.

SC-5.03 Certificates of Insurance

SC-5.03 *Delete the second sentence of paragraph GC-5.03 in its entirety.*

SC-5.04 CONTRACTOR's Liability Insurance

SC-5.04 *Add the following new paragraphs immediately after paragraph GC-5.04.B:*

- C. The limits of liability for the insurance required by paragraph 5.04 of the General Conditions shall provide coverage for not less than the following amounts or greater where required by Laws and Regulations:
1. Worker's Compensation: To meet statutory limits in compliance with the Worker's Compensation Law of Florida. This policy must include Employer Liability with a limit \$100,000 for each accident, \$500,000 disease (policy limit) and \$100,000 disease (each employee). Such policy shall include a waiver of subrogation as against OWNER and ENGINEER on account of injury sustained by an employee(s) of the CONTRACTOR.

2. Commercial General Liability: Coverage shall provide minimum limits of liability of \$1,000,000 per occurrence Combined Single Limit for Bodily Injury and Property Damage. This shall include coverage for:
 - a. Premises/Operations
 - b. Products/Completed Operations
 - c. Contractual Liability
 - d. Independent Contractors
 - e. Explosion
 - f. Collapse
 - g. Underground.
 3. Business Auto Liability: Coverage shall provide minimum limits of liability of \$1,000,000 per occurrence Combined Single Limit for Bodily Injury and Property Damage. This shall include coverage for:
 - a. Owned Autos, and other vehicles
 - b. Hired Autos, and other vehicles
 - c. Non-Owned Autos, and other vehicles.
 4. Special Requirements:
 - a. Ten (10) days prior to the commencement of any work under this Contract, certificates of insurance and endorsement forms in the exact wording and format as presented in these Contract Documents will be provided to the OWNER's Risk Manager for review and approval.
 - b. "Indian River County Florida" will be named as "Additional Insured" on both the General Liability and Auto Liability.
 - c. The OWNER will be given thirty (30) days notice prior to cancellation or modification of any stipulated insurance. Such notification will be in writing by registered mail, return receipt requested and addressed to the OWNER's Risk Manager.
 - d. An appropriate "Indemnification" clause shall be made a provision of the Contract (see paragraph 6.20 of the General Conditions).
 - e. It is the responsibility of the CONTRACTOR to insure that all subcontractors comply with all insurance requirements.
 - f. It should be remembered that these are minimum requirements, which are subject to modification in response to high hazard operation.
 - g. Insured must be authorized to do business and have an agent for service of process in Florida and have Best's Rating of A-VII or better.
 - h. All insurance requirements shall be at the Contractor's sole cost and expense, including any deductible or self-insured retention, without contribution from Indian River County or its insurance carriers.
- D. Additional Insureds:
1. In addition to "Indian River County, Florida," the following individuals or entities shall be listed as "additional insureds" on the CONTRACTOR's liability insurance policies:
 - a. Florida Department of Environmental Protection
- E. Contractor shall be responsible for any deductible or self-insured retention.

SC-5.05 OWNER's Liability Insurance

SC-5.05 Delete paragraph GC-5.05.A in its entirety.

SC-5.06 Property Insurance

SC-5.06 *Delete paragraphs GC-5.06.A, B, and C in their entirety.*

SC-5.06.E *Delete paragraph GC-5.06.E in its entirety*

SC-5.07 Waiver of Rights

SC-5.07 *Delete GC-5.07 (paragraphs A, B, and C) in its entirety.*

SC-5.08 Receipt and Application of Insurance Proceeds

SC-5.08 *Delete GC-5.08 (paragraphs A and B) in its entirety.*

SC-5.09 Acceptance of Bonds and Insurance; Option to Replace

SC-5.09 *Delete GC-5.09 (paragraph A) in its entirety.*

SC-6.02 Labor; Working Hours

SC-6.02.B. *Add the following paragraphs immediately after paragraph GC-6.02.B:*

1. Regular working hours are defined as Monday through Friday, excluding Indian River County Holidays, from 7 a.m. to 5 p.m.
2. Indian River County Holidays are: New Year's Day, Martin Luther King, Jr. Day, Good Friday, Memorial Day, Independence Day, Labor Day, Veterans Day, Thanksgiving Day, Friday after Thanksgiving, Christmas Eve and Christmas Day. Working on these days will not be permitted without prior written permission and approval from the Construction Coordination Manager.
3. The CONTRACTOR shall receive no additional compensation for overtime work, i.e., work in excess of eight hours in any one calendar day or 40 hours in any one calendar week, even though such overtime work may be required under emergency conditions and may be ordered by the ENGINEER in writing.
4. All costs of inspection and testing performed during overtime work by the CONTRACTOR, which is allowed solely for the convenience of the CONTRACTOR, shall be borne by the CONTRACTOR, and a credit given to the OWNER to deduct the costs of all such inspection and testing from any payments otherwise due the CONTRACTOR.
5. All costs of OWNER's employees and costs of ENGINEER's Consultant resulting from overtime work by the CONTRACTOR, which is allowed solely for the convenience of the CONTRACTOR, shall be borne by the CONTRACTOR, and a credit given to OWNER to deduct all such costs from any payments otherwise due the CONTRACTOR.
6. No work shall commence before 7 a.m. or continue after 5 p.m. except in case of emergency upon specific permission of the ENGINEER.

SC-6.06 Concerning Subcontractors, Suppliers, and Others

SC-6.06.C. *Add the following sentence at the end of paragraph GC-6.06.C:*

OWNER or ENGINEER may furnish to any such Subcontractor, Supplier, or other individual or entity, to the extent practicable, information about amounts paid to CONTRACTOR on account of Work performed for CONTRACTOR by a particular Subcontractor, Supplier, or other individual or entity.

SC-6.08 Permits

SC-6.08 *Add the following paragraphs immediately after paragraph GC-6.08.A:*

1. The OWNER has obtained the following permits (copies of these permits are contained in Appendix A):
 - A. St. Johns River Water Management District – Permit No. 446073-1
 - B. Florida Department of Environmental Protection – Permit No. 141651-2
2. The CONTRACTOR shall obtain and pay for all other required permits and licenses. The CONTRACTOR shall provide copies of the permits to the OWNER and ENGINEER and shall comply with all conditions contained in the permits at no extra cost to the OWNER.
3. The CONTRACTOR shall be familiar with all permit requirements during construction and shall be responsible for complying with these requirements. The cost of this effort shall be included in the pay item in which the work is most closely associated with.

SC-9.05 Authorized Variations in Work

SC-9.05.A. *Delete the second sentence in paragraph GC-9.05.A in its entirety.*

SC-11.01 Cost of the Work

SC-11.01.A.1. *Delete paragraph GC-11.01.A.1 in its entirety, and insert the following sentences in its place:*

1. CONTRACTOR will receive payment for actual costs of direct labor and burden (see SC-2.06.B) for the additional or unforeseen work. Labor includes foremen actually engaged in the work; and will not include project supervisory personnel nor necessary on-site clerical staff, except when the additional or unforeseen work is a controlling work item and the performance of such controlling work item actually extends completion of the project due to no fault of the Contractor. Compensation for project supervisory personnel, but in no case higher than a Project Manager's position, shall only be for the pro-rata time such supervisory personnel spent on the contract. In no case shall an officer or director of the Company, nor those persons who own more than 1% of the Company, be considered as project supervisory personnel, direct labor or foremen hereunder. The expenses of performing Work outside of regular working hours, on Saturday, Sunday, or legal holidays, shall be included in the above to the extent authorized by OWNER.

SC-13.03 Test and Inspections

SC-13.03.B. *Delete paragraph GC-13.03.B in its entirety, and insert the following sentences in its place:*

- B. OWNER shall employ and pay for the services of an independent testing laboratory to perform all initial inspections, tests, or approvals required by the Contract Documents except those inspections, tests, or approvals listed immediately below. Subsequent inspections, tests, or approvals required after initial failing inspections, tests, or approvals shall be paid for by the CONTRACTOR by back charge to subsequent applications for payment. The CONTRACTOR shall arrange, obtain, and pay for the following inspections, tests, or approvals:
 1. inspections, tests, or approvals covered by paragraphs 13.03.C and 13.03.D below;

2. costs incurred in connection with tests or inspections conducted pursuant to paragraph 13.04.B shall be paid as provided in said paragraph 13.04.B;
3. tests otherwise specifically provided in the Contract Documents.

SC-13.05 OWNER May Stop the Work

SC-13.05.A. *Delete paragraph GC-13.05.A in its entirety and insert the following paragraph in its place:*

- A. If the Work is defective, or CONTRACTOR fails to supply sufficient skilled workers or suitable materials or equipment, or fails to comply with permit requirements, or fails to comply with the technical specifications, or fails to perform the Work in such a way that the completed Work will conform to the Contract Documents, OWNER may order CONTRACTOR to stop the Work, or any portion thereof, until the cause for such order has been eliminated; however, this right of OWNER to stop the Work shall not give rise to any duty on the part of OWNER to exercise this right for the benefit of CONTRACTOR, any Subcontractor, any Supplier, any other individual or entity, or any surety for, or employee or agent of any of them.

SC-13.07 Correction Period

SC-13.07 A. *Delete the first sentence of paragraph GC-13.07.A in its entirety and insert the following sentence in its place*

- A. If within one year after the date of Final Completion or such longer period of time as may be prescribed by Laws or Regulations or by the terms of any applicable special guarantee required by the Contract Documents or by any specific provision of the Contract Documents, any Work is found to be defective, or if the repair of any damages to the land or areas made available for CONTRACTOR's use by OWNER or permitted by Laws and Regulations as contemplated in paragraph 6.11.A is found to be defective, CONTRACTOR shall promptly, without cost to OWNER and in accordance with OWNER's written instructions: (i) repair such defective land or areas, or (ii) correct such defective Work or, if the defective Work has been rejected by OWNER, remove it from the Project and replace it with Work that is not defective, and (iii) satisfactorily correct or repair or remove and replace any damage to other Work, to the work of others or other land or areas resulting therefrom.

SC-13.07 B. *Delete paragraph GC-13.07.B in its entirety and insert the following sentence in its place*

- B. In special circumstances where a particular item of equipment is placed in continuous service before Final Completion of all the Work, the correction period for that item may start to run from an earlier date if so provided in the Specifications or by Written Amendment.

SC-14.02 Progress Payments

SC-14.02.B.5. *Delete paragraph GC-14.02.B.5.d in its entirety and insert the following paragraph in its place:*

- d. ENGINEER has actual knowledge of the occurrence of any of the events enumerated in paragraph 15.02.A; or

SC-14.02.B.5. *Add the following sentences at the end of paragraph GC-14.02.B.5:*

- e. OWNER has been required to pay ENGINEER additional compensation because of CONTRACTOR delays or rejection of defective Work; or
- f. OWNER has been required to pay an independent testing laboratory for subsequent inspections, tests, or approvals taken after initial failing inspections, tests, or approvals.

SC-14.02.C.1. *Delete paragraph GC-14.02.C.1 in its entirety and insert the following paragraph in its place:*

- C. Payment Becomes Due
 - 1. Payment shall be made by OWNER to CONTRACTOR according to the Local Government Prompt Payment Act. F.S. 218.70 et. seq.

SC-14.04 Substantial Completion

SC-14.04A. *After the third sentence in paragraph GC-14.04A of the General Conditions, delete the remainder of paragraph 14.04A in its entirety and replace with the following:*

“If Engineer considers the Work substantially complete, Engineer will prepare and deliver to Owner a tentative certificate of Substantial Completion that shall fix the date of Substantial Completion. In accordance with the provisions of Florida Statutes section 208.735(7)(a)(2023), upon receipt of the tentative certificate of Substantial Completion from Engineer, the Owner, the Engineer, and the Contractor shall conduct a walk-through inspection of the Project to document a list of any items required to render the Work on the Project complete, satisfactory, and acceptable under this Agreement (herein the “Statutory List”). The Statutory List shall be reduced to writing and circulated among the Owner, the Engineer, and the Contractor by the Owner or the Engineer within 30 calendar days after substantial completion. The Owner and Contractor acknowledge and agree that: 1) the failure to include any corrective work, or pending items that are not yet completed, on the Statutory List does not alter the responsibility of the Contractor to complete all of the Work under this Agreement; 2) upon completion of all items on the Statutory List, the Contractor may submit a pay request for all remaining retainage except as otherwise set forth in this Agreement; and 3) any and all items that require correction under this Agreement and that are identified after the preparation of the Statutory List remain the obligation of the Contractor to complete to the Owner’s satisfaction under this Agreement. After receipt of the Statutory List by the Contractor, the Contractor acknowledges and agrees that it will diligently proceed to complete all items on the Statutory List and schedule a final walk-through in anticipation of final completion on the Project.”

SC-14.04B *Add the following new paragraph immediately after paragraph GC 14.04B:*

C. At the time of delivery of the tentative certificate of Substantial Completion, Engineer will deliver to Owner and Contractor a written recommendation as to division of responsibilities pending final payment between Owner and Contractor with respect to security, operation,

safety, and protection of the Work, maintenance, heat, utilities, insurance, and warranties and guarantees.

D. For construction projects less than \$10 million, at the time the Owner is in receipt of the Certificate of Substantial Completion, the Owner shall have 30 calendar days to provide a list to the Contractor of items to be completed and the estimated cost to complete each item on the list. Owner and Contractor agree that the Contractor's itemized bid shall serve as the basis for determining the cost of each item on the list. For projects in excess of \$10 million, Owner shall have up to 45 calendar days following receipt of Certificate of Substantial Completion of the project to provide contractor with said list.

Payment of retainage

E. Within 20 business days following the creation of the list, Owner shall pay Contractor the remaining contract balance including all retainage previously withheld by Owner except for an amount equal to 150% of the estimated cost to complete all of the items on the list.

Upon completion of all items on the list, the Contractor may submit a payment request for the amount of the 150% retainage held by the Owner. If a good faith dispute exists as to whether one or more of the items have been finished, the Owner may continue to withhold the 150% of the total cost to complete such items. The Owner shall provide Contractor written reasons for disputing completion of the list.

SC-14.07 Final Payment

SC-14.07.C.1. *Delete paragraph GC-14.07.C.1 in its entirety and insert the following paragraph in its place:*

C. Payment Becomes Due

1. Payment shall be made by OWNER to CONTRACTOR according to the "Local Government Prompt Payment Act", Florida Statutes section 218.70, et. seq.

SC-15.01 OWNER May Suspend Work

SC-15.01.A *Delete the last sentence in paragraph GC-15.01.A and insert the following in its place:*

CONTRACTOR shall be allowed an extension of the Contract Times, directly attributable to any such suspension if CONTRACTOR makes a Claim for an extension as provided in paragraph 10.05. CONTRACTOR shall not be allowed an adjustment of the Contract Price and CONTRACTOR shall not be paid on account of loss of anticipated profits or revenue or other economic loss arising out of or resulting from such Work suspension.

SC-15.02 OWNER May Terminate For Cause

SC-15.02.A.5 and SC-15.02.A.6 *Add the following new paragraphs immediately after paragraph GC-15.02.A.4:*

5. CONTRACTOR's violation of Section 02225 – "Erosion Control and Treatment of Dewatering Water From the Construction Site."

6. CONTRACTOR's failure to make payment to Subcontractors or Suppliers for materials or labor in accordance with the respective agreements between the CONTRACTOR and the Subcontractors or Suppliers.
7. CONTRACTOR certifies that it and its related entities as defined by Florida law are not on the Scrutinized Companies that Boycott Israel List, created pursuant to s. 215.4725 of the Florida Statutes, and are not engaged in a boycott of Israel. In addition, if this agreement is for goods or services of one million dollars or more, CONTRACTOR certifies that it and its related entities as defined above by Florida law are not on the Scrutinized Companies with Activities in Sudan List or the Scrutinized Companies with Activities in the Iran Petroleum Energy Sector List, created pursuant to Section 215.473 of the Florida Statutes and are not engaged in business operations in Cuba or Syria.

OWNER may terminate this Contract if CONTRACTOR is found to have submitted a false certification as provided under section 287.135(5), Florida Statutes, been placed on the Scrutinized Companies with Activities in Sudan List or the Scrutinized Companies with Activities in the Iran Petroleum Energy Sector List, or been engaged in business operations in Cuba or Syria, as defined by section 287.135, Florida Statutes.

OWNER may terminate this Contract if CONTRACTOR, including all wholly owned subsidiaries, majority-owned subsidiaries, and parent companies, that exist for the purpose of making profit, is found to have been placed on the Scrutinized Companies that Boycott Israel List or is engaged in a boycott of Israel as set forth in section 215.4725, Florida Statutes.

SC-15.04 CONTRACTOR May Stop Work or Terminate

SC-15.04 *Delete the following text from the first sentence of paragraph GC-15.04.A:*

~~or OWNER fails for 30 days to pay CONTRACTOR any sum finally determined to be due,~~

SC-15.04 *Delete the following text from the second sentence of paragraph GC-15.04.A:*

~~or OWNER has failed for 30 days to pay CONTRACTOR any sum finally determined to be due,~~

SC-16 Dispute Resolution

SC-16.02 Mediation

SC-16 *Add the following new paragraph immediately after paragraph GC-16.01.*

SC-16.02 Mediation

- A. OWNER and CONTRACTOR agree that they shall submit any and all unsettled Claims or counterclaims, disputes, or other matters in question between them arising out of or relating to the Contract Documents or the breach thereof, to mediation by a certified mediator of the 19th Judicial Circuit in Indian River County unless delay in initiating mediation would irrevocably prejudice one of the parties. The mediator of any dispute submitted to mediation under this agreement shall not serve as arbitrator of such dispute unless otherwise agreed.

SC-17 Miscellaneous**SC-17.06 Liens**

Add the following new paragraphs immediately after paragraph GC17.05:

SC-17.06 Liens

- A. This project is a "Public Works" under Chapter 255, Florida Statutes. No merchant's liens may be filed against the OWNER. Any claimant may apply to the OWNER for a copy of this Contract. The claimant shall have a right of action against the CONTRACTOR for the amount due him. Such action shall not involve the OWNER in any expense. Claims against the CONTRACTOR are subject to timely prior notice to the CONTRACTOR as specified in Florida Statutes Section 255.05. The CONTRACTOR shall insert the following paragraph in all subcontracts hereunder:

"Notice: Claims for labor, materials and supplies are not assessable against Indian River County and are subject to proper prior notice to (CONTRACTOR'S Name) and to (CONTRACTOR Surety Company Name), pursuant to Chapter 255 of the Florida Statutes. This paragraph shall be inserted in every sub-subcontract hereunder." The payment due under the Contract shall be paid by the OWNER to the CONTRACTOR only after the CONTRACTOR has furnished the OWNER with an affidavit stating that all persons, firms or corporations who are defined in Section 713.01, Florida Statutes, who have furnished labor or materials, employed directly or indirectly in the Work, have been paid in full. The OWNER may rely on said affidavit at face value. The CONTRACTOR does hereby release, remiss and quit-claim any and all rights he may enjoy perfecting any lien or any other type of statutory common law or equitable lien against the job.

++END OF SUPPLEMENTARY CONDITIONS++

SECTION 00942 – Change Order Form

No. ____

DATE OF ISSUANCE: _____

EFFECTIVE DATE: _____

OWNER: Indian River County
 CONTRACTOR _____
 Project: **TRANS-FLORIDA RAILWAY TRAIL FROM FELLSMERE TO WEST OF I-95**
 OWNER's Project No. **IRC-2115** OWNER'S Bid No. **2024006**
 FM No.: **446073-01-58-01**

You are directed to make the following changes in the Contract Documents:

Description:

Reason for Change Order:

Attachments: (List documents supporting change)

CHANGE IN CONTRACT PRICE:	
Description	Amount
Original Contract Price	\$ _____
Net Increase (Decrease) from previous Change Orders No. _____ to _____:	\$ _____
Contract Price prior to this Change Order:	\$ _____
Net increase (decrease) of this Change Order:	\$ _____
Contract Price with all approved Change Orders:	\$ _____

CHANGE IN CONTRACT TIMES	
Description	Time
Original Contract Time:	(days or dates) _____
Substantial Completion:	_____
Final Completion:	_____
Net change from previous Change Orders No. _____ to _____:	(days) _____
Substantial Completion:	_____
Final Completion:	_____
Contract Time prior to this Change Order:	(days or dates) _____
Substantial Completion:	_____
Final Completion:	_____
Net increase (decrease) this Change Order:	(days or dates) _____
Substantial Completion:	_____
Final Completion:	_____
Contract Time with all approved Change Orders:	(days or dates) _____
Substantial Completion:	_____
Final Completion:	_____

ACCEPTED:
By:
CONTRACTOR (Signature)
Date:

RECOMMENDED:
By:
ENGINEER (Signature)
Date:

APPROVED:
By:
OWNER (Signature)
Date:

SECTION 00948 – Work Change Directive

No. _____

DATE OF ISSUANCE: _____

EFFECTIVE DATE: _____

OWNER: Indian River County

CONTRACTOR _____

Project: **TRANS-FLORIDA RAILWAY TRAIL FROM FELLSMERE TO WEST OF I-95**

OWNER's Project No. **IRC-2115**

OWNER'S Bid No. **2024006**

FM No.: **446073-01-58-01**

You are directed to proceed promptly with the following changes:

Description:

Reason for Change Order:

Attachments: (List documents supporting change)

If OWNER or CONTRACTOR believe that the above change has affected Contract Price any Claim for a Change Order based thereon will involve one or more of the following methods as defined in the Contract Documents.

Method of determining change in Contract Prices

- Unit Prices
- Lump Sum
- Other: _____
- By Change Order:

Estimated increase (decrease) of this Work Change Directive
\$ _____

If the change involves an increase, the estimated amount is not to be exceeded without further authorization.

Method of determining change in Contract Times

- Contractor's Records
- Engineer's Records
- Other: _____
- By Change Order:

Estimated increase (decrease) in Contract Times:

Substantial Completion: _____ days;
Ready for Final Completion: _____ days.

If the change involves an increase, the estimated time is not to be exceeded without further authorization.

ACCEPTED:
By:
CONTRACTOR (Signature)
Date:

RECOMMENDED:
By:
ENGINEER (Signature)
Date:

APPROVED:
By:
OWNER (Signature)
Date:

**** END OF SECTION ****

DIVISION 1 - GENERAL REQUIREMENTS

DIVISION 1 - GENERAL REQUIREMENTS

SECTION 01009 - SPECIAL PROVISIONS

SECTION 01024 - FORCE ACCOUNT

SECTION 01050 - FIELD ENGINEERING AND LAYOUT

SECTION 01091 - REFERENCE STANDARDS

SECTION 01215 - GENERAL QUALITY CONTROL

SECTION 01220 - PROGRESS MEETINGS

SECTION 01310 - CONSTRUCTION SCHEDULES

SECTION 01340 - SUBMITTAL OF SHOP DRAWINGS

SECTION 01520 - CONSTRUCTION FACILITIES AND TEMPORARY CONTROLS

SECTION 01541 - PROTECTION OF THE WORK AND PROPERTY

SECTION 01550 - ACCESS ROADS, PARKING AREAS AND USE OF PUBLIC STREETS

SECTION 01610 - TRANSPORTATION AND HANDLING OF MATERIALS AND EQUIPMENT

SECTION 01611 - STORAGE OF MATERIAL AND EQUIPMENT

SECTION 01630 - SUBSTITUTIONS

SECTION 01710 - SITE CLEANUP AND RESTORATION

SECTION 01820 - POST FINAL INSPECTION

SECTION 01009 - SPECIAL PROVISIONS

1.1 GENERAL

- A. Visits to the construction site may be made by representatives of permitting or governing bodies. Submit details of all instructions from the above to the ENGINEER immediately. The Work will not be accepted by the OWNER until final acceptance has been received from the various Regulatory Agencies having jurisdiction.
- B. Furnish sufficient labor, construction equipment and materials, and work such hours, including night shifts and overtime operations, as may be necessary to insure the prosecution of the work in accordance with the approved progress schedule. If, in the opinion of the ENGINEER, the CONTRACTOR falls behind the progress schedule, take such steps as may be necessary to improve progress, all without additional cost to the OWNER. The ENGINEER shall be compensated for his overtime services in accordance with the Supplementary Conditions, SC-6.02.
- C. All salvageable material and equipment for which specific use, relocation or other disposal is not specifically noted, shall remain the property of the OWNER and shall be delivered to the OWNER at the following location: 4550 41st Street, at the CONTRACTOR's expense. All material and equipment not in salvageable condition, as determined by the ENGINEER and the OWNER, shall be disposed of by the CONTRACTOR, at the CONTRACTOR's expense.
- D. In addition to these Specifications all work must comply with the requirements of the local governing agency, St. Johns River Water Management District, Department of Environmental Protection, Army Corps of Engineers, Indian River Farms Water Control District, and all other applicable State or Federal agencies' specifications and permits. In the event of a conflict, the more stringent specification or requirement shall govern.
- E. Before performing any work outside the designated limits of the work site, secure any necessary permits and authorization from the applicable owner, or verify in writing that such has been previously obtained. Follow all requirements of any said permits or authorization. Give the ENGINEER and appropriate owner ten (10) days minimum notice before commencing construction operations outside the designated limits of the work site.

+ + END OF SECTION + +

SECTION 01024 - FORCE ACCOUNT

1.1 GENERAL

- A. CONTRACTOR shall furnish all labor, materials, equipment and incidentals necessary to perform additional work not covered on the Contract Drawings. The force Account is intended as a contingency for unforeseen work.

1.2 PAYMENT

- A. Lump sum amount for force account work is included in the bid schedule. The value of force account work will be determined in accordance with Article 12 of the General Conditions.

+ + END OF SECTION + +

SECTION 01050 - FIELD ENGINEERING AND LAYOUT

1.1 GENERAL

- A. The CONTRACTOR will furnish all construction staking for the project. All staking from control will be under the supervision of a Florida Registered Land Surveyor.
- B. Develop and make all detail surveys and measurements needed for construction including but not limited to, slope stakes, batter boards, piling layouts and all other working lines, elevations and cut sheets.
- C. Keep a transit and leveling instrument on the site at all times and a skilled instrument man available whenever necessary for layout of the Work.
- D. Provide all material required for benchmarks, control points, batter boards, grade stakes, and other items.
- E. Be solely responsible for all locations, dimensions and levels. No data other than written orders of the ENGINEER shall justify departure from the dimensions and levels required by the Drawings.
- F. Safeguard all points, stakes, grademarks, monuments and benchmarks made or established on the Work, and reestablish same, if disturbed. Rectify all Work improperly installed because of not maintaining, not protecting or removing without authorization such established points, stakes, marks and monuments.
- G. When requested by the ENGINEER, provide such facilities and assistance as may be necessary for the ENGINEER to check line and grade points placed by the CONTRACTOR. Do no excavation or embankment work until all cross-sectioning necessary for determining pay quantities has been completed and checked by the ENGINEER.
- H. The cost of performing engineering and layout work described above shall be included in the contract unit prices for the various items of work to which it is incidental. No separate payment will be made for surveying or engineering.

1.2 SURVEY WORK AND QUALIFICATIONS OF SURVEYOR

- A. Prior to commencing work, the CONTRACTOR shall satisfy himself as to the accuracy of all survey and existing site information as indicated in the Contract Documents. Immediately notify the ENGINEER upon discovery of any errors, inaccuracies or omissions in the survey data. The commencing of any of the work by the CONTRACTOR shall be held as the CONTRACTOR's acceptance that all survey or existing site information is correct and accurate, without any reasonably inferable errors, inaccuracies or omissions.

- B. The CONTRACTOR shall carefully preserve all control stakes, benchmarks, reference points and property corners and will be responsible for any mistake or loss of time caused by their unnecessary loss or disturbance. If the loss or disturbance of the stakes or marks cause a delay in the Work, the CONTRACTOR shall have no claim for damages or extension of time. Control stakes, benchmarks, reference points and property corners disturbed by the CONTRACTOR's work shall be replaced by a Florida Registered Land Surveyor and Mapper, at the CONTRACTOR's expense. In the event the Owner must provide the services of the Florida Registered Surveyor and Mapper to perform this replacement work, the cost of the surveying services will be deducted from any sums due the CONTRACTOR for the work performed under this Contract.

- C. All survey work shall be performed under the guidance and direction of a Florida Registered Surveyor and Mapper.

- D. All survey work for Record Drawings shall be performed by a Florida Registered Surveyor and Mapper.

1.3 STATION BOARDS

- A. CONTRACTOR shall erect and maintain white/black standard FDOT station markers every 100 feet.

1.4 LAYOUT OF STRIPING

- A. Establish by instrument, and mark the finished surface, the points necessary for striping finished roadway in conformance with Section 5-7 of FDOT Standard Specifications.

+ + END OF SECTION + +

SECTION 01091 - REFERENCE STANDARDS**1.1 GENERAL**

- A. Whenever reference is made to the furnishing of materials or testing thereof to conform to the standards of any technical society, organization or body, it shall be construed to mean the latest standard, code, specification or tentative specification adopted and published at the date of advertisement for bids, unless noted otherwise in the Technical Specifications or on the Drawings. When a reference standard is specified, comply with requirements and recommendations stated in that standard, except when they are modified by the Contract Documents, or when applicable laws, ordinances, rules, regulations or codes establish stricter standards. The list of specifications presented in Paragraph B is hereby made a part of the Contract, the same as if repeated herein in full.
- B. Reference to a technical society, organization, or body may be made in the Specifications by abbreviations, in accordance with the following list:

AASHTO	The American Association of State Highway and Transportation Officials
ACI	American Concrete Institute
AGA	American Gas Association
AISC	American Institute of Steel Construction
AISI	American Iron and Steel Institute
ANSI	American National Standards Institute
ASCE	American Society of Civil Engineers
ASTM	American Society for Testing and Materials
AWPA	American Wood Preservers Association
AWWA	American Water Works Association
AWS	American Welding Society
FED.SPEC.	Federal Specifications
CRSI	Concrete Reinforcing Steel Institute
FDEP/DEP	Florida Department of Environmental Protection
DNR	Department of Natural Resources
NCPI	National Clay Pipe Institute
NEMA	National Electrical Manufacturers Association
NEC	National Electric Code
NSPE	National Society of Professional Engineers
OSHA	Occupational Safety and Health Administration

PCI	Prestressed Concrete Institute
FDOT/DOT	Florida Department of Transportation
U. L., Inc.	Underwriter's Laboratories, Inc.
SSPC	Steel Structures Painting Council
SJRWMD	St. Johns River Water Management District

- C. When no reference is made to a code, standard or specification, the standard specifications of ASTM, FDOT, or ANSI shall govern.
- D. In the event of a conflict between the specifications prepared by the ENGINEER and the above referenced specifications and standards, or any other regulatory specification or standard, the more stringent requirement prevails.

+ + END OF SECTION + +

SECTION 01215 - GENERAL QUALITY CONTROL

1.1 DESCRIPTION OF REQUIREMENTS

- A. Definitions: Specific quality control requirements for the work are indicated throughout the Contract Documents. The requirements of this section are primarily related to the performance of the work beyond the furnishing of manufactured products. The term "Quality Control" includes, but is not necessarily limited to, inspection and testing and associated requirements. This section does not specify or modify the OWNER and ENGINEER duties relating to quality review and Contract surveillance.

1.2 RESPONSIBILITY FOR INSPECTIONS AND TESTS

- A. Residual OWNER Responsibility: The OWNER will employ and pay for the services of independent testing laboratories to perform those required inspections and tests.
- B. CONTRACTORS General Responsibility: No failure of test agencies, whether engaged by the OWNER or CONTRACTOR, to perform adequate inspections of tests or to properly analyze or report results, shall relieve the CONTRACTOR of responsibility for the fulfillment of the requirements of the Contract Documents. It is recognized that the required inspection and testing program is intended to assist the CONTRACTOR, OWNER, ENGINEER, and governing authorities in the nominal determination of probable compliance with requirements for certain crucial elements of work. The program is not intended to limit the CONTRACTOR in his regular quality control program, as needed for general assurance of compliance.

1.3 QUALITY ASSURANCE

- A. General Workmanship Standards: It is a requirement that each category of tradesman or installer performing the work be pre-qualified, to the extent of being familiar with the applicable and recognized quality standards for his category of work, and being capable of workmanship complying with those standards.

1.4 PRODUCT DELIVERY-STORAGE-HANDLING

Handle, store and protect materials and products, including fabricated components, by methods and means which will prevent damage, deterioration and losses (and resulting delays), thereby ensuring highest quality results as the performance of the work progresses. Control delivery schedules so as to minimize unnecessary long-term storage at the project site prior to installation.

1.5 PROJECT PHOTOGRAPHS/VIDEOS

- A. The CONTRACTOR shall make provisions, at his expense, for photographs and video tapes of all work areas just prior to construction, and for unusual conditions during construction. The photographs and videos shall show pertinent physical features along the line of construction. The purpose of the videos is to determine any damage to private or public property during construction. The video must be performed by a professional videographer.
- B. Pre-Construction Photographs and Video:
1. Contractor shall provide the Owner with photographs and video record and one copy of the existing conditions prior to construction. These photographs and videos shall be a standard DVD format and shall be narrated.
 2. The photographs and video shall include, but not be limited to, the following items shown in a clear manner:
 - 1) All existing features within the right-of-way.
 - 2) All existing features within the temporary construction easement.
 - 3) All existing features within permanent easements.
 - 4) All existing features adjacent to any construction.
 3. Detail of the photographs and video shall be such that the following examples shall be clear and visible:
 - 1) Cracks in walls.
 - 2) Condition of fencing.
 - 3) Condition of planted areas and types of vegetation.
 - 4) Condition of sodded areas.
 - 5) Conditions of sprinkler systems and associated controls and wiring.
 - 6) Condition of signs.
 - 7) Conditions of lighting and associated wiring.
 - 8) Significant detail of any pre-existing damages physical features shall be shown. The coverage of the photographs and video should include the limits of effects of the use of vibratory rollers.
 - 9) These photographs and video record shall be presented and approved by the Owner prior to the Notice to Proceed. A copy shall be kept in the Contractor's field office.
 - 10) Payment – No additional payment will be made for this work.

+ + END OF SECTION + +

SECTION 01220 - PROGRESS MEETINGS

1.1 SCOPE

- A. Date and Time:
 - 1. Regular Meetings: As mutually agreed upon by ENGINEER and CONTRACTOR.
 - 2. Other Meetings: On call.
- B. Place: CONTRACTOR'S office at Project site or other mutually agreed upon location.
- C. ENGINEER shall prepare agenda, preside at meetings, and prepare and distribute a transcript of proceedings to all parties.
- D. CONTRACTOR shall provide data required and be prepared to discuss all items on agenda.

1.2 MINIMUM ATTENDANCE

- A. CONTRACTOR
- B. SUBCONTRACTOR:
When needed for the discussion of a particular agenda item, CONTRACTOR shall require representatives of Subcontractors or suppliers to attend a meeting.
- C. PROJECT MANAGER
- D. OWNER'S representative, if required.
- E. Utility Representatives
- F. Others as appropriate.
- G. Representatives present for each party shall be authorized to act on their behalf.

1.3 AGENDA

Agenda will include, but will not necessarily be limited to, the following:

- 1. Transcript of previous meeting.
- 2. Progress since last meeting.
- 3. Planned progress for next period.
- 4. Problems, conflicts and observations.
- 5. Change Orders.
- 6. Status of Shop Drawings.
- 7. Quality standards and control.
- 8. Schedules, including off-site fabrication and delivery schedules. Corrective measures, if required.
- 9. Coordination between parties.
- 10. Safety concerns.
- 11. Other business.

++ END OF SECTION ++

SECTION 01310 - CONSTRUCTION SCHEDULES

1.1 GENERAL REQUIREMENTS

- A. No partial payments shall be approved by the ENGINEER until there is an approved construction progress schedule on hand.
- B. Designate an authorized representative who shall be responsible for development and maintenance of the schedule and of all progress and payment reports. This representative shall have direct project control and complete authority to act on behalf of the CONTRACTOR in fulfilling the commitments of the CONTRACTOR's schedules.

1.2 REVISIONS TO THE CONSTRUCTION SCHEDULES

When the ENGINEER requires the CONTRACTOR to submit revised (updated) progress schedules on a monthly basis the CONTRACTOR shall:

- A. Indicate the progress of each activity to the date of submission.
- B. Show changes occurring since the previous submission listing:
 - 1. Major changes in scope.
 - 2. Activities modified since the previous submission.
 - 3. Revised projections of progress and completion.
 - 4. Other identifiable changes.
- C. Provide a narrative report as needed to define:
 - 1. Problem areas, anticipated delays, and the impact on the schedule.
 - 2. Corrective action recommended and its effect.
 - 3. The effect of changes on schedules of other prime contractors.

1.3 SUBMISSION OF THE CONSTRUCTION SCHEDULES

On or before the tenth day after the effective date of the Agreement, submit the initial schedules to the ENGINEER. The ENGINEER will review the schedules and return a review copy to the CONTRACTOR within 21 days after receipt. If required by the ENGINEER, resubmit revised schedules on or before the seventh day after receipt of the review copy. If required by the ENGINEER, submit revised monthly progress schedules with that month's application for payment.

1.4 DISTRIBUTION OF THE CONSTRUCTION SCHEDULES

- A. After receiving approval by the ENGINEER, distribute copies of the approved initial schedule and all reviewed revisions (updated) to:
 - 1. Job site file.
 - 2. Subcontractors.
 - 3. Other concerned parties.
 - 4. OWNER (two copies).
 - 5. ENGINEER

- B. In the cover letter, instruct recipients to report promptly to the CONTRACTOR, in writing, any problems anticipated by the projections shown in the schedules.

+ + END OF SECTION + +

SECTION 01340 - SUBMITTAL OF SHOP DRAWINGS

1.1 SCOPE

- A. Submit shop drawings, product data and samples as required by or inferred by the Drawings and Specifications. Submittals shall conform to the requirements of Article 6.17 of the General Conditions, Section 00700, and as described in this Section.

1.2 SHOP DRAWINGS

- A. Shop drawings are original drawings, prepared by the CONTRACTOR, a subcontractor, supplier, or distributor, which illustrate some portion of the work; showing fabrication, layout, setting, or erection details. Shop drawings are further defined in Article 6.17, Section 00700.
- B. Shop drawings shall be prepared by a qualified detailer and shall be identified by reference to sheet and detail numbers on the Contract Drawings.

1.3 PRODUCT DATA

- A. Product data are manufacturer's standard schematic drawings and manufacturer's catalog sheets, brochures, diagrams, schedules, performance charts, illustrations, and other standard descriptive data. Product data are further defined in Article 6.17, Section 00700.
- B. Modify standard drawings to delete information which is not applicable to the project and supplement them to provide additional information applicable to the project.
- C. Clearly mark catalog sheets, brochures, etc., to identify pertinent materials, products, or models.

1.4 SAMPLES

- A. Samples are physical examples to illustrate materials, equipment, or workmanship and to establish standards by which work is to be evaluated. Samples are further defined in Article 6.17, Section 00700.

1.5 CONTRACTOR'S RESPONSIBILITIES FOR SUBMITTAL OF SHOP DRAWINGS, PRODUCT DATA AND SAMPLES

- A. The CONTRACTOR's responsibilities for submittal of shop drawings, product data, and samples are set forth in paragraph 6.17 of the General Conditions and as further explained herein.
- B. Prior to submission, thoroughly check shop drawings, product data, and samples for completeness and for compliance with the Contract Documents, verify all dimensions and field conditions, and coordinate the shop drawings with the requirements for other related work. Also review each shop drawing before submitting it to the ENGINEER to determine that it is acceptable in terms of the means, methods, techniques, sequences and operations of construction, safety precautions and programs incidental thereto, all of which are the CONTRACTOR's responsibility.
 - 1. It is CONTRACTOR'S responsibility to review submittals made by his suppliers and Subcontractors before transmitting them to ENGINEER to assure proper coordination of the Work and to determine that each submittal is in accordance with its desires and that there is sufficient information about materials and equipment for ENGINEER to determine compliance with the Contract Documents.
 - 2. Incomplete or inadequate submittals will be returned for revision without review.
- C. The CONTRACTOR's responsibility for errors and omissions in submittals is not relieved by the ENGINEER's review of submittals. The CONTRACTOR shall approve the shop drawings based on his in-the-field measurements, prior to submittal to the ENGINEER for his review.
- D. Notify the ENGINEER, in writing at the time of submission, of deviations in submittals from the requirements of the Contract Documents. The CONTRACTOR's responsibility for deviations in submittals from the requirements of the Contract Documents is not relieved by the ENGINEER's review of submittals, unless the ENGINEER gives written acceptance of specific deviations.
- E. Begin no work, which requires submittals until return of submittals with the ENGINEER's stamp and initials or signature indicating the submittal has been reviewed.

1.6 SUBMITTAL REQUIREMENTS AND ENGINEER'S REVIEW FOR SHOP DRAWINGS, PRODUCT DATA AND SAMPLES

- A. Submit to:
Indian River County
Engineering Division
1801 27th Street
Vero Beach, FL 32960

- B. A letter of transmittal shall accompany each submittal. If data for more than one Section of the Specifications is submitted, a separate transmittal letter shall accompany the data submitted for each Section.

- C. At the beginning of each letter of transmittal, provide a reference heading indicating the following:
 - 1. OWNER'S Name
 - 2. Project Name
 - 3. Project Number
 - 4. Transmittal Number
 - 5. Section Number

- D. All submittals shall have a title block with complete identifying information satisfactory to the ENGINEER. The following is a sample Submittal Form that the CONTRACTOR may use:

[The remainder of this page has been left blank intentionally]

CONTRACTOR SUBMITTALS

SUBMITTAL NO.

Contractor:

Date Sent to County _____
No. Copies Sent to County _____
 Original Submittal Re-Submittal

Project Name: RAILS TO TRAILS 1.4 MILE EXTENSION OF THE HISTORIC TRANS-FLORIDA RAIL TRAIL
Project No.: IRC-2115

Shop Drawing Cut Sheet Other _____

Description: _____

Sub-Contractor: _____

Remarks: _____

Reviewing Agency: (As checked below)

Date Received Date Returned No. Copies Ret'd

I R C Engineering Div. _____
 I R C Utilities Services _____

Remarks: _____

IRC Engineering Division

Date Rec'd from Contractor _____

Date Ret'd to Contractor _____

1801 27th Street
Vero Beach, Fl. 32960

No. Copies Ret'd _____

Remarks: _____

Distribution of Copies:
IRC Engineering Division
Office File
Field Office File

- E. All submittals shall bear the stamp of approval and signature of CONTRACTOR as evidence that they have been reviewed by CONTRACTOR. Submittals without this stamp of approval will not be reviewed by the ENGINEER and will be returned to CONTRACTOR.
- F. Assign a number to each submittal starting with No. 1 and thence numbered consecutively. Identify resubmittals by the original submittal number followed by the suffix "A" for the first resubmittal, the suffix "B" for the second resubmittal, etc.
- G. Initially submit to ENGINEER a minimum of two (2) copies of all submittals that are on 11-inch by 17-inch or smaller sheets (no less than 8 1/2-inch x 11-inch).
- H. After ENGINEER completes his review, Shop Drawings will be marked with one of the following notations:
 - 1. Approved
 - 2. Approved as Noted
 - 3. NOT Approved - Resubmit
- I. If a submittal is acceptable, it will be marked "Approved" or "Approved as Noted". One (1) electronic copy of the submittal will be returned to CONTRACTOR.
- J. Upon return of a submittal marked "Approved" or "Approved as Noted", CONTRACTOR may order, ship or fabricate the materials included on the submittal, provided it is in accordance with the corrections indicated.
- K. If a submittal is unacceptable, one (1) copy will be returned to CONTRACTOR with following notation, "NOT Approved - Resubmit".
- L. Upon return of a submittal marked "NOT Approved - Resubmit", make the corrections indicated and repeat the initial approval procedure. Upon return of a submittal so marked, repeat the initial approval procedure utilizing acceptable material or equipment.
- M. Work shall not be performed nor equipment installed without an ENGINEER "Approved" or "Approved as Noted" Shop Drawing.
- N. Submit Shop Drawings well in advance of the need for the material or equipment for construction and with ample allowance for the time required to make delivery of material or equipment after data covering such is approved. CONTRACTOR shall assume the risk for all materials or equipment which is fabricated or delivered prior to the approval of Shop Drawings. Materials or equipment requiring Shop Drawings which have not yet received approval by the ENGINEER shall not be installed on the project. Materials or equipment will not be included in periodic progress payments until approval thereof has been obtained in the specified manner.

- P. ENGINEER will review and process all submittals promptly, but a reasonable time should be allowed for this, for the Shop Drawings being revised and resubmitted, and for time required to return the approved Shop Drawings to CONTRACTOR.
- Q. Furnish required submittals with complete information and accuracy in order to achieve required approval of an item within three submittals. All costs to ENGINEER involved with subsequent submittals of Shop Drawings, Samples or other items requiring approval, will be back-charged to CONTRACTOR in accordance with the General Conditions and the Supplementary Conditions. If the CONTRACTOR requests a substitution for a previously approved item, all of ENGINEER'S costs in the reviewing and approval of the substitution will be back-charged to CONTRACTOR unless the need for such substitution is beyond the control of CONTRACTOR.

+ + END OF SECTION + +

SECTION 01520 - CONSTRUCTION FACILITIES AND TEMPORARY CONTROLS

1.1 SCOPE

- A. Provide all construction equipment and facilities and temporary controls required to satisfactorily complete the work represented on the Drawings and described in the Specifications.

1.2 RESPONSIBILITY

- A. All construction facilities and temporary controls remain the property of the Contractor establishing them and shall be maintained in a safe and useful condition until removed from the construction site.
- B. All false work, scaffolding, ladders, hoistways, braces, pumps, roadways, sheeting, forms, barricades, drains, flumes, and the like, any of which may be needed in construction of any part of the work and which are not herein described or specified in detail, must be furnished, maintained and removed by the CONTRACTOR, who is responsible for the safety and efficiency of such work and for any damage that may result from their failure or from their improper construction, maintenance or operation.
- C. In accepting the Contract, the CONTRACTOR assumes full responsibility for the sufficiency and safety of all hoists, cranes, temporary structures or work and for any damage which may result from their failure or their improper construction, maintenance or operation and will indemnify and save harmless the OWNER and ENGINEER from all claims, suits or actions and damages or costs of every description arising by reason of failure to comply with the above provision.

1.3 TEMPORARY UTILITIES AND SERVICES

- A. **TEMPORARY WATER**
 - 1. Provide a temporary water service as required for all construction purposes and pay for all water used.
 - 2. Furnish potable drinking water in suitable dispensers and with cups for use of all employees at the job.
 - 3. Provide all temporary piping, hoses, etc., required to transport water to the point of usage by all trades.
 - 4. When temporary water service is no longer required, remove all temporary water lines.

B. TEMPORARY SANITARY FACILITIES

1. Provide temporary toilet facilities separate from the job office. Maintain these during the entire period of construction under this Contract for the use of all construction personnel on the job. Provide enough chemical toilets to conveniently serve the needs of all personnel. Properly seclude toilet facilities from public observation.
2. Chemical toilets and their maintenance shall meet the requirements of State and local health regulations and ordinances. Immediately correct any facilities or maintenance methods failing to meet these requirements. Upon completion of work, remove the facilities from the premises.

1.4 SECURITY

Full time watchmen will not be specifically required as a part of the Contract, but the CONTRACTOR shall provide inspection of work area daily and shall take whatever measures are necessary to protect the safety of the public, workmen, and materials, and provide for the security of the site, both day and night.

1.5 TEMPORARY CONTROLS

Take all necessary precautions to control dust and mud associated with the work of this Contract. In dry weather, spray dusty areas daily with water in order to control dust. Take necessary steps to prevent the tracking of mud onto adjacent streets and highways.

1.6 REMOVAL OF TEMPORARY CONSTRUCTION FACILITIES

Remove the various temporary facilities, services, and controls and legally dispose of them as soon as the work is complete. The areas of the site used for temporary facilities shall be properly reconditioned and restored to a condition acceptable to the OWNER.

+ + END OF SECTION + +

SECTION 01541 - PROTECTION OF THE WORK AND PROPERTY

1.1 GENERAL

- A. CONTRACTOR shall be responsible for taking all precautions, providing all programs, and taking all actions necessary to protect the Work and all public and private property and facilities from damage as specified in the General Conditions and herein.
- B. In order to prevent damage, injury or loss, CONTRACTOR'S actions shall include, but not be limited to, the following:
 - 1. Store apparatus, materials, supplies, and equipment in an orderly, safe manner that will not unduly interfere with the progress of the Work or the Work of any other Contractor or utility service company.
 - 2. Provide suitable storage facilities for all materials, which are subject to injury by exposure to weather, theft, breakage, or otherwise.
 - 3. Place upon the Work or any part thereof, only such loads as are consistent with the safety of that portion of the Work.
 - 4. Clean up frequently all refuse, rubbish, scrap materials, and debris caused by construction operations, so that at all times, the site of the Work presents a safe, orderly, and workmanlike appearance.
 - 5. Provide barricades and guard rails around openings, for scaffolding, for temporary stairs and ramps, around excavations, elevated walkways and other hazardous areas.
- C. Except after written consent from proper parties, do not enter or occupy privately-owned land with men, tools, materials or equipment, except on easements provided herein.
- D. Assume full responsibility for the preservation of all public and private property or facility on or adjacent to the site. If any direct or indirect damage is done by or on account of any act, omission, neglect or misconduct in the execution of the Work by the CONTRACTOR, it shall be restored by the CONTRACTOR, at its expense, to a condition equal to or better than that existing before the damage was done.

1.2 BARRICADES AND WARNING SIGNALS

CONTRACTOR's responsibility for the maintenance of barricades, signs, lights, and for providing watchmen shall continue until OWNER accepts the Project.

1.3 TREE AND PLANT PROTECTION

- A. Protect existing trees, shrubs and plants on or adjacent to the site that are shown or designated to remain in place against unnecessary cutting, breaking or skinning of trunk, branches, bark or roots.

- B. Do not store or park materials or equipment within the drip line of trees that are to remain.
- C. Install temporary fences or barricades to protect trees and plants in areas subject to traffic.
- D. Fires shall not be permitted under or adjacent to trees and plants.
- E. Within the limits of the Work, water trees and plants that are to remain, in order to maintain their health during construction operations.
- F. Cover all exposed roots with burlap and keep it continuously wet. Cover all exposed roots with earth as soon as possible. Protect root systems from mechanical damage and damage by erosion, flooding, run-off or noxious materials in solution.
- G. If branches or trunks are damaged, prune branches immediately and protect the cut or damaged areas with emulsified asphalt compounded specifically for horticultural use.
- H. Remove all damaged trees and plants that die or suffer permanent injury and replace them with a specimen of equal or better quality.
- I. Coordinate Work in this Section with requirements of other sections herein.

1.4 PROTECTION OF IRRIGATION

The CONTRACTOR shall be responsible for maintaining in good condition all irrigation systems within the easements, which could be damaged by construction activities. The CONTRACTOR shall repair any irrigation systems damaged by construction activities within two (2) days. Irrigation systems partially within the right-of-way and all intersecting side streets within project limits may be cut off and capped or connected to same system to maintain functionality. The CONTRACTOR shall be responsible for maintaining the functionality of the remaining portion of the system if it should fall outside of the right-of-way.

1.5 PROTECTION OF EXISTING STRUCTURES

- A. Underground Structures:
 - 1. Underground structures are defined to include, but not be limited to, all sewer, water, gas, and other piping, and manholes, chambers, electrical conduits, tunnels and other existing subsurface work located within or adjacent to the limits of the Work.
 - 2. All underground structures known to ENGINEER except service connections for water, sewer, electric, and telephone are shown. This information is shown for the assistance of CONTRACTOR in accordance with the best information available, but is not guaranteed to be correct or complete. The existing utilities shown on the Contract Drawings are located according to the information available to the ENGINEER at the time the Drawings were prepared and have not been

Protection of the Work and Property - 01541-2

independently verified by the OWNER or the ENGINEER. Guarantee is not made that all existing underground utilities are shown or that the locations of those shown are accurate. The locations shown are for bidding purposes only. Finding the actual location of any existing utilities is the CONTRACTOR's responsibility and shall be done before it commences any work in the vicinity. Furthermore, the CONTRACTOR shall be fully responsible for any and all damages, which might be occasioned by the CONTRACTOR's failure to exactly locate and preserve any and all underground utilities. The OWNER or ENGINEER will assume no liability for any damages sustained or costs incurred because of the CONTRACTOR's operations in the vicinity of existing utilities or structures, nor for temporary bracing and shoring of same. If it is necessary to shore, brace, or swing a utility, contact the utility company or department affected and obtain their permission regarding the method to use for such work.

3. Contact the various utility companies which may have buried or aerial utilities within or near the construction area before commencing work. Provide 48 hours minimum notice to all utility companies prior to beginning construction.
4. Schedule and execute all work involving existing utilities in order to minimize necessary interruption of services. Whenever such interruption is necessary for completion of the work, notify the ENGINEER and the appropriate utility at least 48 hours in advance. Perform all work to repair/restore utility service to the satisfaction of the appropriate utility. Include all costs related to service maintenance, interruption, and restoration in the appropriate line item in the Contract.
5. Where it is necessary to temporarily interrupt house or business services, the CONTRACTOR shall notify the owner or occupant, both before the interruption (24-hour minimum), and again immediately before service is resumed. Before disconnecting and pipes or cables, the CONTRACTOR shall obtain permission from their owner, or shall make suitable arrangement for their disconnection by their owner.
6. Explore ahead of trenching and excavation work and uncover all obstructing underground structures sufficiently to determine their location, to prevent damage to them and to prevent interruption of the services which such structures provide. If CONTRACTOR damages an underground structure, restore it to original condition at CONTRACTOR's expense.
7. Necessary changes in the location of the Work may be made by ENGINEER, to avoid unanticipated underground structures.
8. If permanent relocation of an underground structure or other subsurface facility is required and is not otherwise provided for in the Contract Documents, ENGINEER will direct CONTRACTOR in writing to perform the Work, which shall be paid for under the provisions of Article 11 of the General Conditions.

B. Surface Structures:

1. Surface structures are defined as structures or facilities above the ground surface. Included with such structures are their foundations and any extension below the surface. Surface structures include, but are not limited to, buildings, tanks, walls, bridges, roads, dams, channels, open drainage, piping, poles, wires, posts, signs, markers, curbs, walks and all other facilities that are visible above the ground surface.

C. Protection of Underground and Surface Structures:

1. Sustain in their places and protect from direct or indirect injury, all underground and surface structures located within or adjacent to the limits of the Work. Such sustaining and supporting shall be done carefully, and as required by the party owning or controlling such structure. Before proceeding with the work of sustaining and supporting such structure, satisfy the ENGINEER that the methods and procedures to be used have been approved by the party owning same.
2. Assume all risks attending the presence or proximity of all underground and surface structures within or adjacent to the limits of the Work. CONTRACTOR shall be responsible for all damage and expense for direct or indirect injury caused by its Work to any structure. CONTRACTOR shall repair immediately all damage caused by his work, to the satisfaction of the OWNER of the damaged structure.

- D. All other existing surface facilities, including but not limited to, guard rails, posts, guard cables, signs, poles, markers, and curbs which are temporarily removed to facilitate installation of the Work shall be replaced and restored to their original condition at CONTRACTOR'S expense.

1.6 DAMAGE TO EXISTING STRUCTURES AND UTILITIES

- A. The CONTRACTOR shall be responsible for and make good all damage to pavement beyond the limits of this Contract, buildings, telephone or other cables, water pipes, sanitary pipes, or other structures which may be encountered, whether or not shown on the Drawings.
- B. Information shown on the Drawings as to the location of existing utilities has been prepared from the most reliable data available to the Engineer. This information is not guaranteed, however, and it shall be this CONTRACTOR's responsibility to determine the location, character and depth of any existing utilities. He shall assist the utility companies, by every means possible to determine said locations. Extreme caution shall be exercised to eliminate any possibility of any damage to utilities resulting from his activities.

1.7 ADJUSTMENTS OF UTILITY CASTINGS, COVERS AND BOXES

- A. All existing utility castings, including valve boxes, junction boxes, manholes, pull boxes, inlets and similar structures in the areas of construction that are to remain in service shall be adjusted by the CONTRACTOR to bring them flush with the surface of the finished work.

- B. The CONTRACTOR shall coordinate the utilities to ensure proper construction sequencing. CONTRACTOR shall make available survey reference markers to the various utility companies.

+ + END OF SECTION + +

SECTION 01550 - ACCESS ROADS, PARKING AREAS AND USE OF PUBLIC STREETS

1.1 GENERAL

- A. Provide all temporary construction roads, walks and parking areas required during construction and for use of emergency vehicles. Design and maintain temporary roads and parking areas so they are fully usable in all weather conditions.
- B. Prevent interference with traffic and the OWNER's operations on existing roads. Indemnify and save harmless the OWNER from any expenses caused by CONTRACTOR's operations over these roads.
- C. Roadways damaged by CONTRACTOR shall be restored to their original condition by the CONTRACTOR subject to approval of the OWNER or ENGINEER.
- D. Remove temporary roads, walks and parking areas prior to final acceptance and return the ground to its original condition, unless otherwise required by the Contract Documents.

1.2 USE OF PUBLIC STREETS

The use of public streets and alleys shall be such as to provide a minimum of inconvenience to the public and to other traffic. Any earth or other excavated material spilled from trucks shall be removed immediately by the CONTRACTOR and the streets cleaned to the satisfaction of the Owner.

1.3 USE OF PUBLIC STREETS FOR HAUL ROADS

- A. Prior to construction, the CONTRACTOR shall designate all proposed haul roads to be used during the life of the project. Any earth or other materials spilled from trucks shall be removed by the CONTRACTOR and streets cleaned to the satisfaction of the Owner. He further shall be responsible for repairs to any damages caused by his operations, prior to final payment.
- B. All trucks carrying earth shall be covered while moving with an appropriate tarpaulin. Should trucks hauling earth fail to cover their loads, the CONTRACTOR will be given two (2) written warnings, after which the CONTRACTOR shall pay a fine of \$50 per uncovered truck to the Owner when invoked by the Owner to Owner's Engineer. All cleanup shall be the responsibility of the CONTRACTOR.
- C. All trucks/moving equipment shall have backup warning horns in proper working order while on the job site.

+ + END OF SECTION + +

SECTION 01610 - TRANSPORTATION AND HANDLING OF MATERIALS AND EQUIPMENT

1.1 GENERAL

- A. Make all arrangements for transportation, delivery and handling of equipment and materials required for prosecution and completion of the Work.
- B. Shipments of materials to CONTRACTOR or Subcontractors shall be delivered to the site only during regular working hours. Shipments shall be addressed and consigned to the proper party giving name of Project, street number and city. Shipments shall not be delivered to OWNER except where otherwise directed.
- C. If necessary, to move stored materials and equipment during construction, CONTRACTOR shall move or cause to be moved materials and equipment without any additional compensation.

1.2 DELIVERY

- A. Arrange deliveries of products in accord with construction schedules and in ample time to facilitate inspection prior to installation.
- B. Coordinate deliveries to avoid conflict with Work and conditions at site and to accommodate the following:
 - 1. Work of other contractors, or OWNER.
 - 2. Limitations of storage space.
 - 3. Availability of equipment and personnel for handling products.
 - 4. OWNER'S use of premises.
- C. Do not have products delivered to project site until related Shop Drawings have been approved by the ENGINEER.
- D. Do not have products delivered to site until required storage facilities have been provided.
- E. Have products delivered to site in manufacturer's original, unopened, labeled containers. Keep ENGINEER informed of delivery of all equipment to be incorporated in the Work.
- F. Partial deliveries of component parts of equipment shall be clearly marked to identify the equipment, to permit easy accumulation of parts, and to facilitate assembly.
- G. Immediately on delivery, Contractor shall inspect shipment to assure:
 - 1. Product complies with requirements of Contract Documents and reviewed submittals.
 - 2. Quantities are correct.
 - 3. Containers and packages are intact, labels are legible.
 - 4. Products are properly protected and undamaged.

1.3 PRODUCT HANDLING

- A. Provide equipment and personnel necessary to handle products, including those provided by OWNER, by methods to prevent soiling or damage to products or packaging.
- B. Provide additional protection during handling as necessary to prevent scraping, marring or otherwise damaging products or surrounding surfaces.
- C. Handle products by methods to prevent bending or overstressing.
- D. Lift heavy components only at designated lifting points.
- E. Materials and equipment shall at all times be handled in a safe manner and as recommended by manufacturer or supplier so that no damage will occur to them. Do not drop, roll or skid products off delivery vehicles. Hand carry or use suitable materials handling equipment.

+ + END OF SECTION + +

SECTION 01611 - STORAGE OF MATERIAL AND EQUIPMENT

1.1 GENERAL

- A. Store and protect materials and equipment in accordance with manufacturer's recommendations and requirements of Specifications.
- B. Make all arrangements and provisions necessary for the storage of materials and equipment. Place all excavated materials, construction equipment, and materials and equipment to be incorporated into the Work, so as not to injure any part of the Work or existing facilities, and so that free access can be had at all times to all parts of the Work and to all public utility installations in the vicinity of the Work. Keep materials and equipment neatly and compactly stored in locations that will cause a minimum of inconvenience to other contractors, public travel, adjoining owners, tenants and occupants. Arrange storage in a manner to provide easy access for inspection.
- C. Areas available on the construction site for storage of material and equipment shall be as shown or approved by the ENGINEER.
- D. Store materials and equipment which are to become the property of the OWNER to facilitate their inspection and insure preservation of the quality and fitness of the Work, including proper protection against damage by extreme temperatures and moisture.
- E. Do not use lawns, grass plots or other private property for storage purposes without written permission of the OWNER or other person in possession or control of such premises.
- F. CONTRACTOR shall be fully responsible for loss or damage to stored materials and equipment.
- G. Do not open manufacturers containers until time of installation unless recommended by the manufacturer or otherwise specified.
- H. When appropriate store materials on wood blocking so there is no contact with the ground.

+ + END OF SECTION + +

SECTION 01630 - SUBSTITUTIONS

1.1 GENERAL

- A. Requests for review of a substitution shall conform to the requirements of Article 6.05, "Substitutes and Or-Equals," of the General Conditions, and shall contain complete data substantiating compliance of the proposed substitution with the Contract Documents.

1.2 CONTRACTOR'S OPTIONS

- A. For materials or equipment (hereinafter products) specified only by reference standard, select product meeting that standard by any manufacturer, fabricator, supplier or distributor (hereinafter manufacturer). To the maximum extent possible, provide products of the same generic kind from a single source.
- B. For products specified by naming several products or manufacturers, select any one of the products or manufacturers named which complies with Specifications.
- C. For products specified by naming one or more products or manufacturers and stating "or equivalent," submit a request for a substitution for any product or manufacturer which is not specifically named.
- D. For products specified by naming only one product or manufacturer and followed by words indicating that no substitution is permitted, there is no option and no substitution will be allowed.
- E. Where more than one choice is available as a CONTRACTOR's option, select product which is compatible with other products already selected or specified.

1.3 SUBSTITUTIONS

- A. During a period of 15 days after date of commencement of Contract Time, ENGINEER will consider written requests from CONTRACTOR for substitution of products or manufacturers, and construction methods (if specified).
 - 1. After end of specified period, requests will be considered only in case of unavailability of product or other conditions beyond control of CONTRACTOR.
- B. Submit 5 copies of Request for Substitution. Submit a separate request for each substitution. In addition to requirements set forth in Article 6.05 of General Conditions, include in the request the following:
 - 1. For products or manufacturers:
 - a. Product identification, including manufacturer's name and address.
 - b. Manufacturer's literature with product description, performance and test data, and reference standards.
 - c. Samples, if appropriate.

- d. Name and address of similar projects on which product was used, and date of installation.
 2. For construction methods (if specified):
 - a. Detailed description of proposed method.
 - b. Drawings illustrating method.
 3. Such other data as the ENGINEER may require to establish that the proposed substitution is equal to the product, manufacturer or method specified.
- C. In making Request for Substitution, CONTRACTOR represents that:
1. CONTRACTOR has investigated proposed substitution, and determined that it is equal to or superior in all respects to the product, manufacturer or method specified.
 2. CONTRACTOR will provide the same or better guarantees or warranties for proposed substitution as for product, manufacturer, or method specified.
 3. CONTRACTOR waives all claims for additional costs or extension of time related to a proposed substitution that subsequently may become apparent.
- D. A proposed substitution will not be accepted if:
1. Acceptance will require changes in the design concept or a substantial revision of the Contract Documents.
 2. It will delay completion of the Work, or the work of other contractors.
 3. It is indicated or implied on a Shop Drawing and is not accompanied by a formal Request for Substitution from CONTRACTOR.
- E. If the ENGINEER determines that a proposed substitute is not equal to that specified, furnish the product, manufacturer, or method specified at no additional cost to OWNER.
- F. Approval of a substitution will not relieve CONTRACTOR from the requirement for submission of Shop Drawings as set forth in the Contract Documents.
- G. The procedure for review by Engineer will include the following:
1. Requests for review of substitute items of material and equipment will not be accepted by Engineer from anyone other than CONTRACTOR.
 2. Upon receipt of an application for review of a substitution, Engineer will determine whether the review will be more extensive than a normal shop drawing review for the specified item.
 3. If the substitution will not require a more extensive review, Engineer will proceed with the review without additional cost to CONTRACTOR.
 4. If the substitution requires a more extensive review, Engineer will proceed with the review only after CONTRACTOR has agreed to reimburse Owner for the review cost.
 5. Engineer may require CONTRACTOR to furnish at CONTRACTOR's expense additional data about the proposed substitute.

- H. Any redesign of structural members shall be performed by, and the plans signed and sealed by, a Professional Engineer registered in the State of Florida. The redesign shall be at the CONTRACTOR's expense. Any redesign will require an extensive review by the Engineer. The CONTRACTOR must agree to reimburse the Owner for the review cost prior to the Owner's Engineer proceeding with the design review. The ENGINEER's estimated cost of review shall be provided to the CONTRACTOR prior to proceeding with the review to allow the CONTRACTOR the opportunity to rescind the request.
- I. Engineer will be allowed a reasonable time within which to evaluate each proposed substitution. Engineer will be the sole judge of acceptability and shall have the right to deny use of any proposed substitution. The CONTRACTOR shall not order, install, or utilize any substitution without either an executed Change Order or Engineer's notation on the reviewed shop drawing. Owner may require CONTRACTOR to furnish at CONTRACTOR's expense a special manufacturer's performance guarantee(s) or other surety with respect to any substitute and an indemnification by the CONTRACTOR. ENGINEER will record time required by Engineer and Engineer's consultants in evaluating substitutions proposed by CONTRACTOR and in making changes in the Contract Documents occasioned thereby. Whether or not a proposed substitute is used, CONTRACTOR shall reimburse Owner for the charges of Engineer and Engineer's consultants for evaluating each proposed substitute.
- J. Substitute materials or equipment may be proposed for acceptance in accordance with this Section. In the event that substitute materials or equipment are used and are less costly than the originally specified material or equipment, than the net difference in cost shall benefit the Owner and CONTRACTOR in equal proportions. This cost difference shall not be reduced by any failure of the CONTRACTOR to base his bid on the named materials or equipment.

+ + END OF SECTION + +

SECTION 01710 - SITE CLEANUP AND RESTORATION

1.1 SCOPE

Furnish all labor, equipment, appliances, and materials required or necessary to clean up and restore the site after the construction is completed.

1.2 REQUIREMENTS

- A. During the progress of the project, keep the work and the adjacent areas affected thereby in a neat and orderly condition. Remove all rubbish, surplus materials, and unused construction equipment. Repair all damage so that the public and property owners will be inconvenienced as little as possible.
- B. Provide onsite containers for the collection of waste materials, debris, and rubbish and empty such containers in a legal manner when they become full.
- C. Where material or debris has been deposited in watercourses, ditches, gutters, drains, or catch-basins as a result of the CONTRACTOR's operations, such material or debris shall be entirely removed and satisfactorily disposed of during the progress of the work, and the ditches, channels, drains, etc., shall be kept clean and open at all times.
- D. Before the completion of the project, unless otherwise especially directed or permitted in writing:
 - 1. Tear down and remove all temporary buildings and structures;
 - 2. Remove all temporary works, tools, and machinery, or other construction equipment furnished;
 - 3. Remove all rubbish from any grounds occupied; and
 - 4. Leave the roads, all parts of the premises, and adjacent property affected by construction operations, in a neat and satisfactory condition.
- E. Restore or replace any public or private property damaged by construction work, equipment, or employees, to a condition at least equal to that existing immediately prior to the beginning of the operations. To this end, the CONTRACTOR shall restore all highway, roadside, and landscaping work within any right-of-way, platted or prescriptive. Acceptable materials, equipment, and methods shall be used for such restoration.
- F. Thoroughly clean all materials and equipment installed and on completion of the work, deliver the facilities undamaged and in fresh and new-appearing condition.
- G. It is the intent of the Specifications to place the responsibility on the CONTRACTOR to restore to their original condition all items disturbed, destroyed, or damaged during construction. Particular attention will be placed on restoration of canals to equal or better condition than prior to construction.

- H. When finished surfaces require cleaning with cleaning materials, use only those cleaning materials which will not create hazards to health or property and which will not damage the surfaces. Use cleaning materials only on those surfaces recommended by the manufacturer. Follow the manufacturer's directions and recommendations at all times.
- I. Keep the amount of dust produced during construction activities to a minimum. At CONTRACTOR's expense, spray water or other dust control agents over the areas, which are producing the dust. Schedule construction operations so that dust and other contaminants will not fall on wet or newly coated surfaces.

1.3 SITE CLEANUP AND RESTORATION

Prior to final completion, the OWNER, ENGINEER, and CONTRACTOR shall review the site with regards to site cleanup and restoration. Clean and/or restore all items determined to be unsatisfactory by the OWNER or ENGINEER, at no additional expense.

+ + END OF SECTION + +

SECTION 01820 - POST FINAL INSPECTION

1.1 GENERAL

- A. Approximately one year after Final Completion, the OWNER will make arrangements with the Project Manager and the CONTRACTOR for a post final inspection and will send a written notice to said parties to inform them of the date and time of the inspection.
- B. Corrections of defective work noted by OWNER and Project Manager shall comply with the applicable sections of Article 13, General Conditions.
- C. After the inspection, the OWNER will inform the CONTRACTOR of any corrections required to release the performance and payment bonds.

++ END OF SECTION ++

DIVISION 2 - TECHNICAL PROVISIONS

Table of Contents

DIVISION 2 - TECHNICAL PROVISIONS 1

SECTION 001 - TECHNICAL SPECIFICATIONS..... 2

SECTION 004 - SCOPE OF WORK..... 2

SECTION 101 - MOBILIZATION 2

SECTION 102 - MAINTENANCE OF TRAFFIC..... 3

SECTION 104 - PREVENTION, CONTROL, AND ABATEMENT OF EROSION AND WATER POLLUTION 5

SECTION 110 - CLEARING AND GRUBBING..... 15

SECTION 120 - EXCAVATION AND EMBANKMENT..... 16

SECTION 160 - STABILIZING 17

SECTION 285 - OPTIONAL BASE COURSE..... 17

SECTION 334 - SUPERPAVE ASPHALT CONCRETE 18

SECTION 430 - PIPE CULVERTS 18

SECTION 570 - PERFORMANCE TURF..... 18

SECTION 700 - HIGHWAY SIGNING..... 20

SECTION 519 – BOLLARDS (COLLAPSIBLE)..... 21

SECTION 999 - RECORDS/AS-BUILTS 21

SECTION 001 - TECHNICAL SPECIFICATIONS

STANDARD SPECIFICATIONS

- A. All work of this Contract shall conform to the applicable technical specifications of Florida Department of Transportation Standard Specifications for Road and Bridge Construction, January 2022, and Supplemental Specification, Special Provisions and addenda thereto, except as modified and supplemented hereinafter. Reference to Article numbers herein-after apply to the FDOT Standard Specifications, and reference in FDOT Standard Specifications to Department shall be taken as the Owner or its appointed Representative. Wherever the Specifications, Supplementals, etc. may refer to the "Owner", "Department", "State of Florida Department of Transportation", or words relating to offices of State Government, such words shall be taken as meaning Owner or Indian River County, Florida. Wherever the word "Owner's Engineer", "District Engineer", "Engineer", "Project Engineer", etc., appears, it shall be taken to mean the Registered Professional Project Engineer of the Indian River County Public Works Department, Engineering Division acting directly or through duly authorized representatives. Wherever the word "Resident Engineer" appears, it shall be taken to mean an authorized representative of the Owner's Engineer on the Project (Resident Construction Inspector) who will act as an agent for Indian River County, assigned to observe the progress quantity and quality of the work.

The work to be performed for utility work (if any) shall conform to the applicable technical specifications of the "Indian River County Department of Utility Services, Water, Wastewater, and Reclaimed Water Utility Construction Standards" March, 2018 or the current version.

The work to be performed per line items 700 through 711 shall conform to the applicable standards of Indian River County Typical Drawings for Pavement Markings, Signing & Geometrics Revised March 2012.

SECTION 004 - SCOPE OF WORK

Section 4-3.9 Value Engineering Incentive is deleted in its entirety.

SECTION 101 - MOBILIZATION

The work specified in this section shall conform to Section 101 of the Florida Department of Transportation Standard Specifications for Road and Bridge Construction.

- A. The Contractor shall maintain all grassed and landscaped areas within the project limits in a satisfactory condition until final acceptance of the project. Such maintenance within the limits of construction shall include the mowing of all existing grassed areas within the Right-of-Way, removal of all trash and debris on a weekly basis, and keeping vegetation

trimmed on all sidewalks. Grass height shall not exceed 6" without mowing. Clippings shall be removed from sidewalk.

Item of Payment

Payment for the work specified in this item shall be made under:

Bid Item No. 101-1 – Mobilization/Demobilization – Per Lump Sum

SECTION 102 - MAINTENANCE OF TRAFFIC

The work specified in this item shall conform to Section 102 of the Florida Department of Transportation Standard Specifications for Road and Bridge Construction, except as modified herein.

- A. **GENERAL PROVISIONS-DESCRIPTION:** The work specified in this Section consists of maintaining traffic within the limits of the project for the duration of the construction period, including any temporary suspensions of the work. It shall include the construction and maintenance of any necessary detour facilities; the providing of necessary facilities for access to residences, businesses, etc., along the project; the furnishing, installing and maintaining of traffic control and safety devices during construction, the control of dust through the use of calcium chloride if necessary, and any other special requirements for safe and expeditious movement of traffic as may be called for on the plans. The term, Maintenance of Traffic, as used herein, shall include all of such facilities, devices and operations as are required for the safety and convenience of the public as well as for minimizing public nuisance; all as specified in this Itemized Section 14 of these provisions and Paragraph 24 in General Conditions Section.
- B. **BEGINNING DATE OF CONTRACTOR'S RESPONSIBILITY:** The Contractor shall present his Maintenance of Traffic Plan at or before the pre-construction conference. The Maintenance of Traffic Plan shall indicate the type and location of all signs, lights, barricades, striping and barriers to be used for the safe passage of pedestrians and vehicular traffic through the project and for the protection of the workmen. The plan will indicate conditions and setups for each phase of the Contractor's activities.

When the project plans include or specify a specific Maintenance of Traffic Plan, alternate proposals will be considered when they are found to be equal to or better than the plan specified.

In no case may the Contractor begin work until the Maintenance of Traffic Plan has been approved in writing by the Engineer. Modifications to the Maintenance of Traffic Plan that become necessary shall also be approved in writing. Except in an emergency, no changes to the approved plan will be allowed until approval to change such plan has been received.

The cost of all work included in the Maintenance of Traffic Plan shall be included in the pay

item for Maintenance of Traffic.

The Contractor shall be responsible for performing daily inspections, including weekends and holidays, with some inspections at nighttime, of the installations on the project and replace all equipment and devices not conforming with the approved standards during that inspection. The project personnel will be advised of the schedule of these inspections and be given the opportunity to join in the inspection as is deemed necessary.

- C. TRAFFIC CONTROL - STANDARDS: The FDOT Design Standards For Design, Construction, Maintenance and Utility Operations On The State Highway System, Edition as dated on the plans set forth the basic principles and prescribes minimum standards to be followed in the design, application, installation, maintenance and removal of all traffic control devices and all warning devices and barriers which are necessary to protect the public and workmen from hazards within the project limits. The standards established in the aforementioned manual constitute the minimum requirements for normal conditions, and additional traffic control devices warning devices, barriers or other safety devices will be required where unusual, complex or particularly hazardous conditions exist.

The above referenced standards were developed using F.H.W.A., U.S.D.O.T. Manual on Uniform Traffic Control Devices (MUTCD).

- D. TRAFFIC CONTROL DEVICES, WARNING DEVICES AND BARRIERS - INSTALLATION: The responsibility for installation and maintenance of adequate traffic control devices, warning devices and barriers, for the protection of the travel in public and workmen, as well as to safeguard the work area in general shall rest with the Contractor. Consideration shall be given to recommendations of the Engineer. The required traffic control devices, warning devices and barriers shall be erected by the Contractor prior to creation of any hazardous condition and in conjunction with any necessary re-routing of traffic. The Contractor shall immediately remove, turn or cover any devices or barriers which do not apply to existing conditions. All traffic control devices shall conform to MUTCD standards and shall be clean and relatively undamaged. Damaged devices diminishing legibility and recognition, during either night or day conditions, are not acceptable for use.
- E. NO WAIVER OF LIABILITY: The Contractor shall conduct his operations in such a manner that no undue hazard will result due to the requirements of this article, and the procedures and policies described therein shall in no way act as a waiver of any of the terms of the liability of the Contractor or his surety.
- F. Contractor's Maintenance of Traffic Plan shall maintain continuous vehicular traffic at all times.
- G. The Changeable Variable Message Sign shall be used as necessary. The location, message, and duration shall be as directed by Engineer.
- H. In addition to above, the Contractor shall comply with INDIAN RIVER COUNTY TRAFFIC ENGINEERING DIVISION SPECIAL CONDITIONS FOR RIGHT-OF-WAY CONSTRUCTION in

Appendix C.

Item of Payment

Payment for the work specified in this item shall be made under:

Bid Item No. 102-1 – Maintenance of Traffic – Per Lump Sum

SECTION 104 - PREVENTION, CONTROL, AND ABATEMENT OF EROSION AND WATER POLLUTION**PART 1 – GENERAL****1.1 SCOPE**

- A. This Section covers erosion control and the treatment of dewatering water and stormwater runoff from the construction site and work area. Pollution control measures shall prevent polluted or turbid waters from being discharged from the construction site or work area to undeveloped portions of the site or offsite, including but not limited to Multiple Separate Storm Sewer Systems (MS4s) and Waters of the State.
- B. The OWNER considers pollution from dewatering water and stormwater runoff from a construction site or work area to be a very serious offense. The CONTRACTOR is solely responsible for preventing pollution caused by dewatering water and stormwater runoff from the construction site or work area. Note that state regulations do not allow mixing stormwater and dewatering groundwater in the same release – separate and independent discharges are required.
- C. Pollution control measures specified herein represent minimum standards to be adhered to by the CONTRACTOR throughout the Project's construction. The OWNER reserves the right to require the CONTRACTOR to employ additional pollution control measures, when in the sole opinion of the OWNER, they are warranted. If site specific conditions require additional erosion and stormwater pollution control measures during any phase of construction or operation to prevent erosion or to control sediment or other pollution, beyond those specified in the Drawings, the Project's approved Stormwater Pollution Prevention Plan (SWPPP), or herein, implement additional best management practices as necessary, in accordance with [Chapter 4, "Best Management Practices for Erosion and Sedimentation Control" of the Florida Erosion and Sediment Control Inspector's Manual](#) and other references as may be applicable or required by regulatory permits.
- D. The OWNER may terminate this Contract if the CONTRACTOR fails to comply with this Section. Alternatively, the OWNER may halt the CONTRACTOR's operations until the CONTRACTOR is in full compliance with this Section. If the OWNER halts the CONTRACTOR's Work as a result of failure to comply with this Section, the Contract time clock will continue to run.

- E. In addition to these Specifications, comply with [Chapter 4 - "Best Management Practices for Erosion and Sedimentation Control"](#) and [Chapter 5 - "Best Management Practices for Dewatering"](#) of the [Florida Erosion and Sediment Control Inspector's Manual](#). In the event of a conflict between the referenced chapters and these Specifications, the more stringent requirement shall prevail.
- F. Submit to SJRWMD a "Notice to District of Dewatering Activity" (SJRWMD Form No. 40C-2.900(12)) prior to commencement of dewatering in accordance with F.A.C. 40C-2.042(9). Provide a copy of the Notice to Indian River County.

1.2 PERMITS

- A. The OWNER has obtained certain permits for this project and they are listed in [paragraph 6.08.B of the EJCDC Standard General Conditions of the Construction Contract \(General Conditions\)](#). [Per paragraph 6.08.C of the General Conditions](#), apply for and obtain all other required federal, state, and local permits, licenses, sampling, and tests.
- B. Provide copies of all approved permits to the OWNER and ENGINEER and comply with all conditions contained in all permits at no extra cost to the OWNER. If there is a conflict between any permit requirement and these Specifications or requirements between permits, the more stringent specification or requirement shall govern.
- C. Pay for all required water quality sampling and laboratory tests.

1.3 GENERAL

- A. Do not begin any other construction work until the pollution control and treatment system has been constructed in accordance with approved plans, permits, and these Specifications; and the installed system has been examined by the OWNER for compliance.
- B. From time to time, the OWNER or ENGINEER will inspect the pollution control and treatment system and may take effluent samples for analysis by a testing laboratory selected and paid for by the OWNER. If at any time, the OWNER or ENGINEER determines that the pollution control and treatment system is not in compliance with the approved system, the OWNER or ENGINEER will shut the portion of the project down that is not in compliance, and it shall remain shut-down until the pollution control and treatment system is properly constructed or repaired, and complies with the approved pollution control and treatment system plans, specifications, contract documents, and permits.
- C. Schedule construction to minimize erosion and stormwater runoff from the construction site. Implement erosion control measures on disturbed areas as soon as practicable in portions of the site where construction activities have temporarily or permanently ceased, but in no case more than 7 days after the construction activity in that portion of the site has temporarily or permanently ceased. In addition to other temporary erosion control measures that may be implemented, application of polyacrylamide is required on all such disturbed areas within 7 days after the construction activity in that portion of the site has

temporarily or permanently ceased, unless final landscaping has been installed. Polyacrylamide application shall be as specified herein. Include polyacrylamide application in the Project's SWPPP.

- D. Inspect each pollution control system at least once per day and after each rainfall event. Clean and maintain each pollution control system as required until the system is no longer needed. If a water quality violation occurs, immediately cease all work contributing to the water quality violation and correct the problem. Immediately report all water quality violations to the OWNER. Immediately report the discharge of any hazardous substance to the State Warning Point at 800-320-0519 or 850-413-9911.
- E. Discharge shall not violate State or local water quality standards in receiving waters, nor cause injury to the public health or to public or private property, nor to the Work completed or in progress. The receiving point for water from construction operations shall be approved by the applicable owner, regulatory agency, and the ENGINEER. The receiving point shall be shown on the Project SWPPP.
- F. Promptly repair all damage at no cost to the OWNER.

1.4 SUBMITTALS

- A. Shop Drawings: Submit shop drawings of the proposed pollution control and treatment systems in accordance with [Section 1340](#).
- B. Approved Stormwater Pollution Prevention Plan.
- C. "Contractor's Affidavit Regarding Erosion Control and Treatment of Dewatering Water and Stormwater From Construction Activities"

1.5 STORMWATER TREATMENT AND EROSION CONTROL SYSTEM RESPONSIBILITY

- A. Prepare a site-specific design of the erosion and stormwater pollution control system. Install and maintain all erosion and stormwater pollution control devices under the supervision of a State Certified Stormwater, Erosion, and Sedimentation Control Inspector. Maintain the erosion and stormwater pollution control devices until in the ENGINEER's sole opinion, the devices are no longer necessary (such time not to extend past the date the OWNER formally accepts the project as complete). Before beginning construction, submit to Indian River County, Florida Department of Environmental Protection (FDEP) and other applicable regulatory agencies for review and approval, a Stormwater Pollution Prevention Plan (SWPPP), prepared by the certified erosion control subcontractor. Construction shall not begin until the SWPPP has been approved by Indian River County, FDEP, and all applicable regulatory agencies. Submit the approved SWPPP to the ENGINEER before beginning construction. Include in the SWPPP, the "Contractor's Affidavit Regarding Erosion Control and Treatment of Dewatering Water and Stormwater From Construction Activities" (located at the end of this Section).

1.6 "POLLUTION" AND CERTAIN UNCONTESTABLE POLLUTION EVENTS DEFINED

- A. With respect to this Section and as may be further defined in paragraphs [1.6.B](#), [1.6.C](#), and [1.6.D](#), "pollution" is the presence in off-site waters of any substances, contaminants, or manmade or human-induced impairment of off-site waters or alteration of the chemical, physical, biological, or radiological integrity of off-site water in quantities or at levels which are or may be potentially harmful or injurious to human health or welfare, animal or plant life, or property. Pollutants to be removed include but are not limited to, sediment and suspended solids, solid and sanitary wastes, phosphorus, nitrogen, pesticides, oil and grease, concrete truck washout, stucco mixer washout, curb machine washout, washout from other construction equipment, construction chemicals, and construction debris.
- B. When the Discharge is Directly Into an Existing Water Body An existing water body (including ditches and canals) is defined to be polluted by the CONTRACTOR's operations when at any time, the turbidity of the water immediately downstream of the CONTRACTOR's discharge point(s) is at least 29 nephelometric turbidity units (NTUs) higher than the turbidity of the background water upstream of the discharge point(s). [See [Fla. Administrative Code 62-302.530](#)] Exception: When the discharge is directly into or through an outfall discharging into "Outstanding Florida Waters," designated by [Florida Statute 403.061\(27\)](#), the turbidity of the discharged water cannot exceed the turbidity of the immediate receiving water. The ENGINEER or OWNER shall determine the locations where the turbidity is measured.
- C. When the Discharge is not Directly Into an Existing Water Body In some instances, dewatering water or stormwater runoff from the construction site or work area may reach a water body indirectly, such as by overland flow. If the discharge water's TSS and turbidity measurements exceed pre-construction background values by 20 percent for TSS and 29 NTUs for turbidity, then the discharge is defined to be polluted.
- D. When Pollution Always Occurs The discharge from a construction site or work area is defined to be polluted whenever the pH of the discharge is less than 6.5 or greater than 8.5, or whenever any of the following is present in the discharge water:
- (1) Hazardous waste or hazardous materials in any quantity,
 - (2) Any petroleum product or by-product in any quantity,
 - (3) Any chemical in any quantity, or
 - (4) Concentrated pollutants.
- E. Above paragraphs [1.6.B](#), [1.6.C](#), and [1.6.D](#) do not in any way, limit the types of conditions in which pollution may be determined to occur.

1.7 PENALTIES FOR NONCOMPLIANCE WITH THIS SECTION

- A. In addition to the OWNER's specific remedies, if erosion or pollution is caused by dewatering water or stormwater runoff from the construction site, the OWNER may report the violations to Indian River County Stormwater Enforcement, SJRWMD, FDEP, Indian River Farms Water

Control District (or other F. S. Chapter 298 Drainage District, as appropriate), and other pertinent regulatory or enforcement agencies.

PART 2 - MATERIALS AND INSTALLATION

2.1 GENERAL

- A. Polyacrylamide: As required in Paragraph 1.3.C, place polyacrylamide (PAM) on bare ground to reduce the potential for erosion and cover it with hay, jute, or mulch. PAM may also be used in water bodies to remove turbidity. In all cases, use the anionic form of polyacrylamide that does not stick to fish gills. For PAM information and its proper application, a contact is Applied Polymer Systems, Inc., (678) 494-5998, www.siltstop.com.
- B. Staked Silt Fences:
1. General: Use silt fences to control runoff from the construction site where the soil has been disturbed.
 2. Installation: Install per the manufacture's recommendations and as specified herein. In general, install the silt fence in a manner that allows it to stop the water long enough for the sediment to settle while the water passes through the silt fence fabric. All supporting posts shall be on the down-slope side of the fencing. Place the bottom of the fabric 6-inches minimum, under compacted soil to prevent the flow of sediment underneath the fence. Place silt fences away from the toe of slopes. Otherwise, work shall conform to Section 104 of the Florida Department of Transportation Standard Specifications for Road and Bridge Construction.
 3. Product: All material shall be new and unused. Use FDOT Types III through IV silt fences where large sediment loads are anticipated, where slopes are 1:2 (vertical: horizontal) or steeper, or as directed by the ENGINEER; otherwise use FDOT Type II silt fence.
- C. Turbidity Barriers:
1. General: Use turbidity barriers to control sediment contamination of rivers, lakes, ponds, canals, etc.
 2. Installation: Install per the manufacturer's recommendations and per Section 104 of the Florida Department of Transportation Standard Specifications for Road and Bridge Construction unless directed otherwise by the ENGINEER.
 3. Product: All material shall be new and unused. The turbidity barrier shall be a pervious barrier and the fabric color shall be yellow. Use staked turbidity barriers in water less than one-foot deep. Use floating turbidity barriers in water one-foot or deeper.
- D. Sedimentation Control From Dewatering or Pumping Operations Using Filter Bags:
1. Filter bags shall be manufactured using a polypropylene non-woven geotextile and sewn by a double-needle machine, using a high strength nylon thread. The bag shall have a fill spout large enough to accommodate a 4-inch pump discharge hose. Straps shall be attached to the bag to secure the hose and prevent pumped water from escaping without being filtered.

2. Installation: Install in accordance with the manufacturer's specifications. Use as many filter bags as required, at no additional cost to the OWNER. Legally dispose of the bags offsite, at no cost to the OWNER. If the bags are placed on aggregate to facilitate filtration efficiency, do not use limerock aggregate – use non-calcareous rock.
 3. Product: The filter bag shall be supplied with lifting straps.
 - a. "DIRTBAG 53 or 55 as applicable," supplied by ACF Environmental, Inc. (1-800-448-3636).
 - b. "DANDY DEWATERING BAG" supplied by Dandy Products, Inc. (1-800-591-2284).
 - c. Or equivalent.
- E. Curb Inlet Protection:
1. Filter stormwater before it enters curb inlets.
 2. Installation: Install in accordance with the manufacturer's specifications. Use as many of the specified filtration devices as required, at no additional cost to the OWNER.
 3. Product: All materials shall be new and unused. The length of the curb inlet filtration device shall be at least 2-feet longer than the curb inlet opening.
 - a. "GUTTERBUDDY," supplied by ACF Environmental, Inc. (1-800-448-3636).
 - b. Or equivalent.
- F. Catch Basin Protection:
1. Filter stormwater before it enters catch basins (drop inlets). The filter "sack" shall be manufactured from woven polypropylene geotextile and sewn by a double-needle machine, using a high strength nylon thread. The sack shall be manufactured to fit the opening of the catch basin or drop inlet and it shall have the following features: two dump straps attached at the bottom to facilitate emptying; lifting loops as an integral part of the system to be used to lift the sack from the basin; and a colored restraint chord approximately halfway up the sack to keep the sides away from the catch basin walls. The colored restraint chord shall also serve as a visual means of indicating when the sack should be emptied.
 2. Installation: Install in each catch basin in accordance with the manufacturer's specifications. Use as many of the specified filtration devices as required, at no additional cost to the OWNER.
 3. Product: All materials shall be new and unused.
 - a. "SILTSACK" (regular flow), supplied by ACF Environmental, Inc. (1-800-448-3636).
 - b. "FloGuard+PLUS," supplied by Kristar Enterprises, Inc. (1-800-579-8819).
 - c. Or equivalent.
- G. Construction Site Egress Driveways: Minimize the transport of sediment and soil from the construction site or work area by vehicle wheels. Construct a crushed rock driving surface at the vehicle exit point(s). Locate the site egress driveways a minimum of 25 feet from all drainage inlets or pipes. Provide an area large enough to remove the sediment and soil from vehicle wheels before the vehicle leaves the construction site or work area. Provide wash-

down stations as required to wash vehicle tires and retain all washwater on-site. Do not use limerock.

- H. Rock and Stone for Erosion Control and Pollution Control and Treatment:
1. Crushed Limerock: Limerock shall not be used under any circumstance.
 2. Acceptable Material: FDOT #4 non-calcareous aggregate, washed and meeting the requirements of FDOT Standard Specifications for Road and Bridge Construction, Section 901.
- I. Hay Bales: Hay bales shall not be used.

PART 3 - EXECUTION

- A. Design, construct, and maintain the pollution control and treatment system to minimize erosion and capture and remove pollutants from the construction site and from all other areas disturbed by construction activities.
- B. Apply polyacrylamide in strict accordance with the polyacrylamide manufacturer/supplier's recommendations and specifications.
- C. REPAIR ALL EROSION DAMAGE – At no additional cost to the OWNER and regardless of the state of completion of the Work, immediately clean all dirt and debris from all pipes and drainage structures; and repair all flooding, washouts, and all other erosion damage to the Work. This responsibility shall not end until Final Acceptance of the Work by the OWNER. Included is damage caused by erosion of any kind (e.g. wind, waves, stormwater runoff, hurricanes, etc.) including Acts of God. Restore all erosion damaged areas to design grades and elevations. Also, refer to [General Conditions 6.13.B](#).

Item of Payment

Payment for the work specified in this item shall be made under:

- Bid Item No. 104-1 – Artificial Coverings/Erosion Control Abatement Products – Per Square Yard
 Bid Item No. 104-10-3 – Sediment Barrier – Per Linear Feet
 Bid Item No. 104-15 – Soil Tracking Prevention Device – Per Each

[The remainder of this page was left blank intentionally]

PERMITTEE’S AFFIDAVIT REGARDING POLLUTION

This sworn statement is submitted to Indian River County for the following project:

TRANS-FLORIDA RAILWAY TRAIL FROM FELLSMERE TO WEST OF I-95

STATE OF _____

COUNTY OF _____

Personally, before me the undersigned authority, appeared

_____, who upon oath duly administered, stated as follows:

1. This sworn statement is submitted by the PERMITTEE,

_____ whose business address is

and (if applicable) its Federal Identification No.(FEIN) is _____

2. My name is _____ and my relationship to the

entity named above is _____

(if signing as Owner’s Agent, attach Letter of Authorization to Sign from Owner)

3. PERMITTEE understands and agrees that in addition to complying with the terms and conditions of the Stormwater Management System Permit issued by Indian River County, Permittee is responsible for complying with the terms and conditions of the following as applicable to the site:

- (a) State of Florida Generic Permit for Stormwater Discharge From Large and Small Construction Activities (for projects one acre or larger),
- (b) Stormwater Pollution Prevention Plan (regardless of project size),
- (c) St. Johns River Water Management District permit(s) (regardless of project size),
- (d) Florida Department of Environmental Protection permit(s) (regardless of project size),
- (e) All other permits required for this project not specifically listed herein, and
- (f) All Codes and Ordinances of Indian River County.

4. PERMITTEE understands and agrees that “pollution” as defined by Florida Statutes Chapter 403.031(7) includes: “. . . the presence in the outdoor atmosphere or waters of the state of any substances, contaminants, noise, or manmade or human-induced impairment of air or waters or alteration of the chemical, physical, biological, or radiological integrity of air or water in quantities or at levels which are or may be potentially harmful or injurious to human health or

welfare, animal or plant life, or property or which unreasonably interfere with the enjoyment of life or property, including outdoor recreation unless authorized by applicable law.”

5. PERMITTEE understands and agrees that in addition to the definition set forth in Item 4 above, “pollution” is also defined by Florida Administrative Code 62-302.530 and as may be further defined in the Indian River County permit(s).
6. PERMITTEE understands that Indian River County requires the design, installation, and maintenance of proper erosion control measures at all times UNTIL Final Acceptance of the Project by the OWNER.
7. PERMITTEE understands that there are civil and criminal penalties for pollution listed in Florida Statutes Ch. 403.141 and Ch. 403.161 and that there are other penalties listed in Indian River County’s permits, including but not limited to, Indian River County issuing a Cease and Desist Order for the project. CONTRACTOR understands that it may be liable for these and other penalties if offsite pollution occurs as a result of activities associated with the Project.
8. Transfer of Ownership or County Issued Permits:
 - (a) Transfer of Interest in Real Property: Within twenty-one (21) days of any transfer of ownership or control of the real property at which the permitted activity, facility, or system is located or authorized, the Permittee shall notify in writing, both the Indian River County Engineering Division and the Indian River County Stormwater Division of the transfer. Permittee shall provide the name, mailing address, and telephone number of the transferee and a copy of the instrument effectuating the transfer. Said notification is in addition to notifying the County Attorney’s Office as required by County Code.
 - (b) Transfer of a County Permit. To transfer a County issued permit, Permittee must provide (1) the information required in Item 8(a); (2) a written statement from the proposed transferee that it will be bound by all terms and conditions of the permit; and (3) a new “Permittee’s Affidavit” form properly executed by the transferee. Upon proper receipt of these items the County shall transfer the permit to the transferee.
 - (c) Permittee is encouraged to request a permit transfer prior to the sale or legal transfer of the real property at which a permitted facility, system, or activity is located or authorized. However, the transfer shall not be effective prior to the sale or legal transfer.
 - (d) An “Illicit Discharge Sign” must be present at the site at the time of transfer. Replacement or additional signs may be obtained from the Indian River County Public Works Department at a cost of \$30.00 per sign.

Under penalty of perjury, PERMITTEE declares that it has read the foregoing affidavit and the facts stated in it are true.

FURTHER AFFIANT SAYETH NAUGHT

CONTRACTOR: _____

Authorized Signature: _____

Printed Name: _____

Date: _____

Work Telephone: _____

Mobile Telephone: _____

STATE OF _____

COUNTY OF _____

Sworn to (or affirmed) and subscribed before me by means of physical presence or online notarization, this ____ day of _____, 20____, by _____ (name of person making statement).

(Signature of Notary Public - State of Florida)
(Print, Type, or Stamp Commissioned Name of Notary Public)

who is personally known to me or who has produced _____ as identification.

++ END OF SECTION ++

SECTION 110 - CLEARING AND GRUBBING

The work specified in this item shall conform to Section 110 of the Florida Department of Transportation Standard Specifications for Road and Bridge Construction with the following modifications:

- A. Prior to any clearing and grubbing, the contractor will stake the right-of-way. Unimproved areas shall be cleared of trees, logs, stumps, brush, vegetation, rubbish and other perishable or objectionable matter within limits shown on the plans excepting for certain trees and shrubs shown on the plans or as directed by the Engineer which are to remain undisturbed and protected. Stumps and roots between slope stakes in cuts and in embankments 3 feet or less in depth shall be removed to a depth of 18 inches below subgrade. No stumps, roots, or perishable matter of any description shall remain under concrete slabs or footing, including pavement and sidewalks.
- B. No trees shall be removed or relocated until the Engineer or his representative has marked all trees to be saved, after a review of the project site with the Contractor's representative.
- C. Where the final pavement or structural work will be close to existing trees, the Contractor shall exercise care in the vicinity of the trees. Further, the Contractor shall saw cut along the edge of the outside limits of the stabilization, structure subgrade or sidewalk to a minimum depth of 4 feet below the finish grade and paint with a commercial grade pruning paint the ends of all sawn roots. If directed by the Engineer or where shown on the drawings, work shall be done by hand in order to protect the trees.
- D. The Contractor shall exercise care when working in the vicinity of all trees to remain so as to not damage or remove major root structures. The Contractor shall not pull hair or major root structures. All severed roots shall be sawn clean and paint with pruning paint. Stumps, roots, etc., shall be completely removed and disposed of by the Contractor. Undesirable, dead, and/or damaged trees (as so designated by the Engineer) shall be removed.
- E. All trees to be removed shall be disposed off site; burning will be strictly prohibited.
- F. All trees or shrubs which are to remain shall be preserved and protected by the Contractor. Where the removal of valuable trees or shrubs specifically for transplanting is required, this work shall be done in cooperation with the Owner and at no additional expense to the Owner.
- G. All items to be removed shall be excavated to their full depth. All culverts removed from residential driveway entrances within the right-of-way shall become the property of the respective homeowner. Those homeowners not desiring the culverts may donate them to the County free of charge. (See Paragraph C, Special Provisions) The Contractor shall transport the culverts to the County's storage yard. All metal castings for catch basins, manholes, or other structures shall be carefully removed and stored in the County's Storage Yard if they are deemed salvageable by the Engineer. The excavated materials shall be removed from the job site and disposed in a location designated or approved by the Owner.

Any culverts, structures or any material excavated or removed from the project site under clearing and grubbing deemed unsalvageable by the Engineer shall be disposed of in a legal manner by the Contractor. Where required, suitable material as approved by the Engineer shall then be backfilled and compacted to restore the original contour of the ground. The fill material shall be backfilled and compacted in accordance with Section 120 of these specifications.

- H. No additional payment will be made, nor will additional work, or change orders be authorized for work needed to remove, relocate, protect, or otherwise account for in the construction of the work depicted in the plans, for any feature, or item that would be apparent from a careful inspection of the site and review of the plans, even though such feature or item is not specifically called out in the plans. It is therefore essential the contractor make such inspection and review.
- I. The unit price bid for this item shall include the cost of all labor, tools, and equipment necessary to excavate, remove, and dispose of those items as directed by the Engineer and where designated on the Drawings. The cost of restoration and backfill and compaction for the specific area of removal shall also be included under this item.

Item of Payment

Payment for the work specified in this item shall be made under:

Bid Item No. 110-1-1 – Clearing and Grubbing – Per Acre

SECTION 120 - EXCAVATION AND EMBANKMENT

- A. Earthwork, including earthwork for drives outside the right-of-way limits, shall be paid for as embankment. Cost shall include all work specified in this section and Section 120 of the FDOT Standard Specifications for Road and Bridge Construction. Such price and payment shall specifically include all cost of any roadway, lateral ditch or canal, and final dressing operations.
- B. Earthwork quantities shall be considered as in-place material with no shrinkage or expansion factors.
- C. Subsoil Excavation - Any excavation below the proposed bottom elevation of the select fill, isolated swale bottom locations, isolated locations for pipe installations and as approved by the engineer shall be paid for as subsoil excavation. Approximately 2.0 ft of subsoil excavation is required in sublateral canals. Cost of replacement embankment shall be included in cost of subsoil excavation. Contractor shall coordinate with county representative prior to any subsoil excavation.
- D. Embankment - General Requirements for Embankment Materials: The following is added after the first paragraph of Subarticle 120-7.2:

Roadway Design Standard Index No. 505, Embankment Utilization Details is modified by the addition of the following:

Any stratum or stockpile or soil which contains obvious pockets of highly organic material may be designated as muck or unsuitable for construction of subgrade by the Owner.

Backfill material containing more than 2.0% by weight of organic material, as determined by FM 1-T 267 and by averaging the test results for three randomly selected samples from each stratum or stockpile of a particular material, shall not be used in construction of the reinforced volume. If an individual test value of the three samples exceeds 3.0%, the stratum or stockpile will not be suitable for construction of the reinforced volume.

No A-8 material permitted in embankment.

Item of Payment

Payment for the work specified in this item shall be made under:

Bid Item No. 120-1 – Regular Excavation - Per Cubic Yard

Bid Item No. 120-6 – Embankment - Per Cubic Yard

SECTION 160 - STABILIZING

A. Section 160 is modified by the addition of the following:

"The stabilization thickness indicated on plans shall be considered a minimum thickness. Thickness will vary to conform to the lines, and grades shown in the plans." Minimum L.B.R. = 40
- No under-tolerance.

Item of Payment

Payment for the work specified in this item shall be made under:

Bid Item No. 160-4 – Type B Stabilization 12" (LBR-40) - Per Square Yard

SECTION 285 - OPTIONAL BASE COURSE

A. Sub Article 285-4 is modified by the addition of the following:

Base material, thickness and requirements are described in the construction plans. Only one type of alternate base material shall be used. No additional payment will be made for base thickness in excess of the specified thickness

Item of Payment

Payment for the work specified in this item shall be made under:

Bid Item No. 285-704 – Optional Base Group 4 (6" Cemented Coquina (LBR 100)) – Per Square Yard

Bid Item No. 285-706 – Optional Base Group 6 (8" Cemented Coquina (LBR 100)) – Per Square Yard

Bid Item No. 285-711 – Optional Base Group 11 (12" Cemented Coquina (LBR 100)) – Per Square Yard

SECTION 334 - SUPERPAVE ASPHALT CONCRETE

The work specified in this item shall conform to Section 334 of the Florida Department of Transportation Standard Specifications for Road and Bridge Construction.

Sub article 334-8.1 through 334-8.3 – Basis of Payment shall be deleted in its entirety.

Sub article 334-8.4 – Payment shall be amended as follows:

Item of Payment

Bid Item No. 334-1-12 – Superpave Asphalt Concrete Traffic B (Type SP-9.5, 1.5”) – Per Ton

Bid Item No. 334-1-13 – Superpave Asphalt Concrete Traffic C (Type SP-9.5, 1”) (FPL Easement Area) – Per Ton

Bid Item No. 334-1-13A – Superpave Asphalt Concrete Traffic C (Type SP-12.5, 1”) (FPL Easement Area) – Per Ton

SECTION 430 - PIPE CULVERTS

The work specified in this item shall conform to Section 430 of the Florida Department of Transportation Standard Specifications for Road and Bridge Construction.

Item of Payment

Payment for the work specified in this item shall be made under:

Bid Item No. 430-175-115 – Pipe Culvert, Optional Material, Round, 15” S/CD (RCP) – Per Linear Foot

Bid Item No. 430-175-124 – Pipe Culvert, Optional Material, Round, 24” S/CD (RCP) – Per Linear Foot

Bid Item No. 430-175-224 – Pipe Culvert, Optional Material, Round, 19”x30” S/CD (ERCP) – Per Linear Foot

SECTION 570 - PERFORMANCE TURF

The work specified in this item shall conform to Section 570 of the Florida Department of Transportation Standard Specifications for Road and Bridge Construction.

- A. Description: Sod for the project shall be of the variety that is common to the area and of a variety approved by the Engineer. This work shall also include mowing, to be mowed at maximum 6" height with a mulching mower.
- B. Work Included: Scope of Work: The work specified in this section consists of the establishing of a stand of grass, within the project, right-of-way, easements, and other areas indicated on the Drawings, by furnishing and placing grass sod. Also included are fertilizing, watering and maintenance as required to assure a healthy stand of grass. Two applications of fertilizer will be required with the initial application being fertilizer and the second application being “weed and feed”.
- C. Guarantee: All sodded areas shall be guaranteed for one year after date of final acceptance.

Replacement of Defective Sod: Any dead sod or sod showing (less than 95% of a square) indication of probable non-survival or lack of health and vigor, or which do not exhibit the characteristics to meet specifications, shall be replaced within two weeks of notice from Owner or Engineer. All replacement sod shall be furnished/installed at no additional cost to the Owner and shall be guaranteed for three months. All replacement shall meet original specifications.

The Contractor shall notify the Owner and Engineer ten days prior to the end of the guarantee period and such guarantee shall be extended until notification is received.

At the end of the guarantee period, all sod that is dead or in unsatisfactory growth shall be replaced within two weeks.

- D. Fertilizer: Commercial fertilizers shall comply with the Indian River County Fertilizer Ordinance 2013-012 and Supplement Ordinance 2013-014 (see Appendix B).
- E. Water for Grassing: Contractor shall provide the water used in the sodding operations as necessary to meet the requirements of Article 570-3.6.
- F. Preparation of Ground: The area over which the sod is to be placed shall be scarified or loosened to a depth and then raked smooth and free from debris. Where the soil is sufficiently loose and clean, the Owner, at his discretion, may authorize the elimination of ground preparation.
- G. Application of Fertilizer: Before applying fertilizer, the soil pH shall be brought to a range of 6.0 - 7.0.

Contractor shall apply two (2) applications. The initial shall be fertilizer and the second application shall be "weed and feed".

The fertilizer shall be spread uniformly over the sodded area at the rate of 436 pounds per acre, or 10 pounds per 1,000 square feet, by a spreading device capable of uniformly distributing the material at the specified rate.

Contractor shall apply applications as per manufacturer's specification. All tickets from bags shall be handed over to the County Inspector.

On steep slopes, where the use of a machine for spreading or mixing is not practicable, the fertilizer shall be spread by hand and raked in and thoroughly mixed with the soil to a depth of approximately 2 inches.

- H. Placing Sod: The sod shall be placed on the prepared surface, with edges in close contact and shall be firmly and smoothly embedded by light tamping with appropriate tools.

Where sodding is used in drainage ditches, the setting of the pieces shall be staggered so as to avoid a continuous seam along the line of flow. Along the edges of such staggered areas, the offsets of individual strips shall not exceed 6 inches. In order to prevent erosion caused by vertical edges at the outer limits, the outer pieces of sod shall be tamped so as to produce a featheredge effect.

Where sodding is placed abutting paved shoulder, the contractor is to ensure that the finished sod elevation is 1½" below paved shoulder.

On slopes greater than 3:1, the Contractor shall prevent the sod from sliding by means of wooden pegs driven through the sod blocks into firm earth, at suitable intervals.

Sodding shall not be performed when weather and soil conditions are, in the Engineer's opinion, unsuitable for proper results.

Sod shall be placed around all structures, equipment pads, etc.

- I. Watering: The areas on which the sod is to be placed shall contain sufficient moisture, as determined by the Engineer, for optimum results. After being placed, the sod shall be kept in a moist condition to the full depth of the rooting zone for at least 2 weeks. Thereafter, the Contractor shall apply water as needed until the sod roots and starts to grow for a minimum of 60 days (or until final acceptance, whichever is latest).
- J. Maintenance: The Contractor shall, at his expense, maintain the sodded areas in a satisfactory condition until final acceptance of the project. Such maintenance shall include repairing of any damaged areas and replacing areas in which the establishment of the grass stand does not appear to be developing satisfactorily.

Replanting or repair necessary due to the Contractor's negligence, carelessness or failure to provide routine maintenance shall be at the Contractor's expense.

The Contractor shall maintain the sodded area up to the final acceptance date as directed by the Engineer. Grass height shall not exceed 6" without mowing. Clippings shall be removed from sidewalk.

- K. Article 570-9. The first two paragraphs under this Article are deleted and the following is added:

The contract unit price for performance turf shall include the costs of sod, fertilizer (2 applications), sidewalk sweeping after mowing, mowing, pegging disposal of clippings, water, tools, equipment, labor and all other incidentals necessary.

Item of Payment

Payment for the work specified in this item shall be made under:

Bid Item No. 570-1-2 – Performance Turf, Sod (Match Existing) - Per Square Yard

SECTION 700 - HIGHWAY SIGNING

- A. Signing for traffic control shall conform to the requirements of the Standard Specifications, Manual on Uniform Traffic Control Devices, Supplemental Specifications, Roadway and Traffic Design Standards, manufacturer's specifications.
- B. Traffic Signs: All existing signs which are the property of the Owner shall be transported to the Indian River County Road and Bridge Maintenance Yard by the Contractor during construction if they are within the construction limits. Care shall be exercised by the Contractor during removal, storage and relocation so as not to damage the signs. If any damage occurs, as

determined by the Owner's Engineer or Resident Construction Inspector, the sign shall be replaced by the Contractor with no compensation.

Item of Payment

Payment shall be made under:

Bid Item No. 700-1-11 – Scrub Jay Signage (Installation Only) - Per Assembly

Bid Item No. 700-1-11A – Single Post Sign, up to 12SF - Per Assembly

SECTION 519 – BOLLARDS (COLLAPSIBLE)

Item of Payment

Payment shall be made under:

Bid Item No. 519-78 – Bollards (Collapsible) – Per Each

SECTION 999 - RECORDS/AS-BUILTS

GENERAL

Maintain, prepare and provide the ENGINEER with record documents as specified below, except where otherwise specified or modified within the scope of work provided in the specific project contract documents. The Contractor and/or Developer shall be responsible for, and required to provide, Record Drawings as outlined in this section.

MAINTENANCE OF RECORD DOCUMENTS:

1. Maintain in CONTRACTOR's field office in clean, dry, legible condition complete sets of the following project documents: Drawings, Specifications, Addenda, approved Shop Drawings, samples, photographs, Change Orders, other modifications of Contract Documents, test records, survey data, Field Orders, and all other documents pertinent to CONTRACTOR'S Work.
2. Provide files and racks for proper storage and easy access.
3. Make documents available at all times for inspection by ENGINEER and OWNER.
4. Do not use record documents for any other purpose and do not remove them from the field office.
5. Label each document "RECORD DRAWING" in 2-inch high printed letters.
6. Keep record documents current at all times.
7. No work shall be permanently concealed until the required record data has been obtained.

RECORD / AS-BUILT DRAWINGS

- A. During the construction operation, the CONTRACTOR shall maintain records of all deviations from the approved Project Plans and Specifications and shall prepare therefrom "RECORD"

drawings showing correctly and accurately all changes and deviations from the work made during construction to reflect the work as it was actually constructed.

- B. The Record/As-Built survey shall be performed and subsequent plans prepared by a Professional Surveyor and Mapper, registered in the state of Florida and certified to the standards set forth in Chapter 472, Florida Statutes and Chapter 5J-17.050 Florida Administrative Code (Florida Minimum Technical Standards).
- C. Field measurements of vertical or horizontal dimensions of constructed improvements shall be obtained so that the constructed facility can be delineated in such a way that the location of the construction may be compared with the construction plans. Clearly shown by symbols, notations, or delineations, those constructed improvements located by the survey.
- D. All vertical information (elevations) provided on the Record Drawings shall be referenced to the North American Vertical Datum of 1988 (NAVD 88) unless otherwise specified by the Project Engineer.
- E. The horizontal information provided on the Record Drawings shall be referenced to the State of Florida, State Plane Coordinate System, Florida East Zone as established by Global Positioning System (GPS) which meets or exceeds Third Order Class I Accuracy Standards according to current publication of the Federal Geodetic Control Committee (FGCC) procedures.
- F. All Record/As-Built drawings shall be prepared in digital format (ACAD Civil 3D 2013) and shall utilize the digital design drawings as prepared by the Project Engineer as a base for the Record/As-Built drawings. It is the responsibility of the Surveyor to request these files from the Contractor or Project Owner in order to produce the Record/As-Built drawing set.
- G. ALL improvements proposed to be constructed as shown on the approved construction plans shall be field measured upon completion and shown on the Record/As-Built survey. Any improvements that appear in both plan and profile views shall show the Record/As-Built information in both views.
- H. The following items are required to be shown on all Indian River County project Record/As-Built drawings submitted to the County:

DRAINAGE:

1. Right-of-way Swale/Drainage – All culvert inverts, elevations and station offsets; inlet grate and bottom elevations; swale beginning and end bottom elevations; and highs and lows along top of bank. Size of swale.
2. Pipe Culvert/PVC Sleeves – All inverts, pipe size, stations and offsets.
3. Outfalls – All pipe inverts, pipe size, elevations and station offsets, weir box elevations, weir elevation, bleeder elevation and sizes.
4. Roadway/Off Site Drainage – All inverts, elevations and station offsets; manhole top elevation; grate top elevations.

5. Retention Ponds – Provide perimeter elevations, grade breaks, depths and calculated pond areas at control elevation and grade breaks above and below water surface. Show as-built of typical cross section as shown on design plan.

ROADWAY:

1. Stations and offsets related to controlling baseline and elevations of all structures, side street and major driveway radius returns (edge of pavement), bends and/or change in direction of roadway alignment, minimum of 1000' intervals along roadway alignment.
2. Elevations along Profile Grade Line (PGL), of all edge of pavements on each side of Profile Grade Line (PGL), at medians at the high/low and PVI points along Profile Grade Line (PGL).
3. All final Elevations to be plotted on PGL AND Plan & Profile sheets as applicable.
4. Elevations of edge of pavement and flow line at curb inlets and on the adjacent edge of pavement at curb inlets.

WATER, FORCE, AND RECLAIMED WATER MAINS:

1. Show size and type of material used to construct mains.
2. Show horizontal location and elevation of all tees, crosses, bends, terminal ends, valves, fire hydrants, air release valves, and sampling points, etc., by distances from known reference points.
3. Show location, size and type of material of all sleeves and casing pipes.
4. Elevation and horizontal location of all storm sewers, gravity sewers including laterals, force mains, water mains, etc. which are crossed; including clearance dimension at all conflicts or crossings.
5. Top of pipe elevation and horizontal location of all water and force main stub-outs.
6. Horizontal location of all services at the property lines.
7. Horizontal and vertical location of pipe including size of all mains and ground elevation shall be obtained at one-hundred (100) foot intervals. Contractor shall place temporary PVC stand pipes (tell-tales) at each of the one-hundred (100) foot intervals and at all fittings and conflicts/crossings to facilitate the record drawing survey. The tell-tale pipes shall be constructed of 2-inch PVC pipe, shall be placed on the top of the pipes to be surveyed, and shall be removed by the Contractor after completion of the field survey by the "As-Built" Professional Surveyor.
8. Location of fire lines.
9. Dedicated easement locations, identified by O.R. Book and Page Number.

GRAVITY SEWER:

1. Manholes: Elevation of top rim, bottom elevation and invert of each influent and effluent line.
2. Show distance between manholes center-to-center and horizontal location by baseline station and offset.
3. Show material size and type used to construct sewer mains.
4. Show length (center of manhole to end of stub) distances from known reference points

- or baseline offsets, and elevation of stub-outs.
5. Show which services have twenty (20) foot length of DIP at water main crossings.
 6. Show station and offset location of sanitary services' at property line. Particular care in dimensioning needed in special situations, i.e., cul-de-sacs and locations where services are not perpendicular to wye.
 7. Show invert elevation of sanitary service at property line.
 8. Any and all necessary dedicated easement locations, identified by O.R. Book and Page Number.

PUMP / LIFT STATION:

Record Drawings shall show elevations for the top and bottom and diameter of wet well along with invert of effluent line. Record Drawings should also indicate the make, model number, horsepower, impeller and condition point of pumps selected and installed, shape of wet well, location of control panel, location of pump out connection, float level settings, any deviation from the plans, and serial number(s) of the pump(s).

SURVEY CONTROL

1. Install/re-establish: It shall be the contractor's responsibility to hire a Professional Surveyor and Mapper as defined per Chapter 472, Florida Statutes, to replace any horizontal and vertical control shown on the engineering plans that was destroyed during construction.
2. New roadway alignment control points (survey baseline or controlling line and all points as indicated on the plans or control sheet) upon final roadway completion. Include all intersections and side streets. State plane coordinates and elevations for all control points.
3. If shown on plans or not: Any Public Land Corner or Governmental Survey Control point(s), vertical control (bench marks), property corners destroyed and/or disturbed during the scope of the project shall be properly re-established as per standards as set forth within Florida Statutes, Administrative code and Minimum Technical Standards for that type of survey. All said surveying mentioned above shall be performed under the direct supervision of a registered Professional Surveyor and Mapper in the state of Florida and certified accordingly. Said Governmental agency(s) shall be notified in writing of disturbance and re-establishments.

RECORD/AS-BUILTS DRAWINGS FORMAT - SUBMITTAL

- A. ENGINEER will supply the CONTRACTOR with the electronic file of the approved construction plans for the input of the As-Built (record) information.
- B. CONTRACTOR shall deliver seven (7) certified sets of Record/As-Builts with Electronic Drawing files prepared in AutoCAD Civil 3D 2013 AND PDF format or in current version as agreed by the ENGINEER.

- C. CONTRACTOR's surveyor shall review, sign and seal As-Builts or Record drawing(s). Said drawing(s) shall clearly state type of survey, positional tolerances, adhere and be certified to by a registered Professional Surveyor and Mapper in the state of Florida, any standards set forth by Florida Statutes, Administrative code and Minimum Technical Standards for As-Built/Record surveys.
- D. All Record/As-Built drawings are subject to review and approval by County Surveyor.

ACCURACY

The CONTRACTOR will be held responsible for the accuracy and completeness of Record Drawings and Electronic As-Builts and shall bear any costs incurred in finding utilities as a result of incorrect data furnished by the CONTRACTOR.

COMPLETION OF WORK

Upon Substantial Completion of the Work, deliver Record Drawings/As-Built Drawings to ENGINEER. Final payment will not be made until satisfactory record documents are received and approved by ENGINEER.

AERIAL PHOTOGRAPH

The CONTRACTOR shall provide aerial photographs of the project every 30 days during construction. The photographs shall be done in a manner to show the construction progress for the entire length of the project. The photographs can be angled and not prepared to a particular scale, however, must be detailed enough to identify the work in detail.

Item of Payment

Payment for the work specified in this item shall be made under:

Bid Item No. 999-1 – Asbuilt Surveying and Record Drawing Preparation (By Registered Surveyor) – Per Lump Sum

Board of Professional Surveyors and Mappers
Record As-Built Survey Checklist

Lic. Name _____ Date: _____

Project Name: **TRANS-FLORIDA RAILWAY TRAIL FROM FELLSMERE TO WEST OF I-95**

Project No.: **IRC-2115**

Chapter 61G17-6 Minimum Technical Standards F.A.C.

61G17-6.003 General Survey, Map, and Report Content Requirements

☐ **(1) REGULATORY OBJECTIVE: The public must be able to rely on the accuracy of measurements and maps produced by a surveyor and mapper. In meeting this objective, surveyors and mappers must achieve the following minimum standards of accuracy, completeness, and quality:**

☐ **(a) Accuracy of survey measurements based on the type of survey and expected use.**

☐ **(b) Measurements made in accordance with the United States standard, feet or meters.**

☐ **(c) Records of measurements maintained for each survey (check field notes.)**

☐ **(d) Measurement and computation records dated.**

☐ **(e) Measurement and computation records substantiate the survey map.**

☐ **(f) Measurement and computation records support accuracy statement (closure calculations or redundant measurements, if applicable.)**

(2) Other More Stringent Requirements:

☐ **(a) Met more stringent requirements set by federal, state, or local governmental agencies.**

(3) Other Standards and/or Requirements that Apply to All Surveys, Maps, and/or Survey Products:

☐ **(a) REGULATORY OBJECTIVE: In order to avoid misuse of a survey and map, the surveyor and mapper must adequately communicate the survey results to the public through a map, report, or report with an attached map.**

(b) Survey map or report identified the responsible surveyor and mapper and contain standard content. In meeting this objective, surveyors and mappers must meet the following minimum standards of accuracy, completeness, and quality:

☐ (c) Type survey stated on map and report:

As-Built Survey

Construction Layout Survey

Boundary Survey

Control Survey

Condominium Survey

Hydrographic Survey

Mean High Water Line Survey

Specific or Special Purpose Survey

Quantity Survey

Topographic Survey

Record Survey

☐ (d) Name, certificate of authorization number, and street and mailing address of the business entity on the map and report.

☐ (e) Name and license number of the surveyor and mapper in responsible charge.

☐ (f) Name, license number, and street and mailing address of a surveyor and mapper practicing independent of any business entity on the map and report.

☐ (g) Survey date (date of data acquisition.)

☐ (h) Revision date for any graphic revisions (when survey date does not change.)

☐ (i) Map and report statement “Survey map and report or the copies thereof are not valid without the signature and the original raised seal of a Florida licensed surveyor and mapper.”

☐ (j) Insurance statement in ¼” high letters “The survey depicted here is not covered by professional liability insurance” if there is no professional liability insurance.

☐ (k) Additions or deletions to survey maps or reports by other than the signing party or parties is prohibited without written consent of the signing party or parties.

☐ (l) All computed data or plotted features shown on survey maps supported by accurate survey measurements unless clearly stated otherwise.

☐ (m) Bearings, distances, coordinates, and elevations shown on a survey map shall be substantiated by survey measurements unless clearly stated otherwise.

☐ (n) Bearing reference (well established and monumented line)

☐ (o) A designated “north arrow”

☐ (p) Stated scale or graphic scale

☐ (q) Abbreviations in legend or notes.

☐ (r) Special conditions and any necessary deviation from the standards noted upon the map or report.

☐ (s) Responsibility for all mapped features stated on the map or report

☐ (t) Map or report clearly states the individual primarily responsible for the map or report when mapped features have been integrated with others.

(u) Map Accuracy.

(1) Vertical Feature Accuracy:

- ☐ **(a) Vertical Control: Field-measured control for elevation information shown upon survey maps or reports shall be based on a level loop or closure to a second benchmark.**
- ☐ **(b) Closure in feet must be accurate to a standard of plus or minus .05 ft. times the square root of the distance in miles.**
- ☐ **(c) All surveys and maps or reports with elevation data shall indicate the datum and a description of the benchmark(s) upon which the survey is based.**
- ☐ **(d) Minor elevation data may be obtained on an assumed datum provided the base elevation of the datum is obviously different than the established datum.**

(2) Horizontal Feature Accuracy:

- ☐ **(a) Horizontal Control: All surveys and maps or reports expressing or displaying features in a publicly published coordinate system shall indicate the coordinate datum and a description of the control points upon which the survey is based.**
- ☐ **(b) Minor coordinate data may be obtained and used on an assumed datum provided the numerical basis of the datum is obviously different than a publicly published datum.**
- ☐ **(c) The accuracy of control survey data shall be verified by redundant measurements or traverse closures. All control measurements shall achieve the following closures:**

Commercial/High Risk Linear: 1 foot in 10,000 feet;
Suburban: Linear: 1 foot in 7,500 feet;
Rural: Linear: 1 foot in 5,000 feet;
- ☐ **(d) When statistical procedures are used to calculate survey accuracies, the maximum acceptable positional tolerance, based on the 95% confidence level, should meet the same equivalent relative distance standards as set forth in 61G17- 6.003(3)(p)(2.) (c) F.A.C.**
- ☐ **(e) Intended Display Scale: All maps or reports of surveys produced and delivered with digital coordinate files must contain a statement to the effect of: "This map is intended to be displayed at a scale of 1/___ or smaller".**

61G17-6.004 Specific Survey, Map, and Report Requirements

(1) As-Built/Record Survey:

- ☐ (a) Obtained field measurements of vertical or horizontal dimensions of constructed improvements so that the constructed facility can be delineated in such a way that the location of the construction may be compared with the construction plans.**
- ☐ (b) Clearly shows by symbols, notations, or delineations, those constructed improvements located by the survey.**
- ☐ (c) All maps prepared shall meet applicable minimum technical standards.**
- ☐ (d) Vertical and horizontal accuracy of the measurements made shall be such that it may be determined whether the improvements were constructed consistent with planned locations.**

(END OF SECTION)

APPENDIX A

PERMITS

FDEP – Permit No. 31-0423078-001-SFG
SJRWMD – PDEX 192063-1 – Permit Exemption



FLORIDA DEPARTMENT OF Environmental Protection

Bob Martinez Center
2600 Blair Stone Road
Tallahassee, FL 32399-2400

Ron DeSantis
Governor

Jeanette Nuñez
Lt. Governor

Shawn Hamilton
Secretary

March 10, 2023

Indian River County, Public Works
c/o James Ennis
1801 27th Street
Vero Beach, FL 32960
jennis@ircgov.com

File No.: 31-0423078-001-SFG, Indian River County
File Name: IRC Rails Phase 2 Trail Extension of the Historic Trans-Florida Rail Trail

Dear Mr. Ennis:

On September 9th, 2022, the Florida Department of Environmental Protection (Department) received a notice of intent to use General Permits (GP), pursuant to Chapter 62-331.214, of the Florida Administrative Code (F.A.C.), to construct a 12-foot-wide paved trail along the western edge of an existing pedestrian trail on the west side of Interstate 95 (I-95) as part of the Rails to Trails project. The proposed work includes installation of three culverts to restore flow and rehydrate three large wetland systems bisected and isolated by the original trail constructed in the early 1900's. Installation of the three culverts will require temporary impacts to 0.02 acres of freshwater non-forested, herbaceous wetlands (Wet Prairie FNAI) adjacent to the Saint Sebastian River, a Class III Florida waterbody. The project was designed to avoid permanent impacts and minimize any unavoidable, temporary impacts. Mitigation is not proposed for the 0.02 acres of temporary impacts due to the proposed improvement to flow, and expansion of potential habitat for existing wildlife. The activities authorized by this permit are located 1,700 feet north of County Road 512 (CR-512) and west of I-95 to the City of Fellsmere limits at Sections 20, 21 and 22, Township 31 South, Range 38 East, Indian River County, Florida 32960 (Latitude 27°46'20.31" N, Longitude 80°33'41.47" W).

Your intent to use a general permit has been reviewed by Department staff for State 404 Program authorization. **Your project qualifies for authorization.** However, this letter does not relieve you from the responsibility of obtaining other federal, state, or local authorizations that may be required for the activity.

State 404 Program Review – Approved

Based on the forms, drawings, and documents revised with your notice, it appears that the project meets the requirements for the General Permit under Rules 62-331.214, F.A.C. Any activities performed under a general permit are subject to general conditions required in Rule 62-331.201, F.A.C., the conditions of

Rules 62-331.214, F.A.C. (attached), and any specific conditions, below. Any deviations from these conditions may subject the permittee to enforcement action and possible penalties. Please read each section carefully.

Please be advised that the construction phase of the GP must be completed by December 22, 2025. State 404 Program permits cannot be extended or renewed.

SPECIFIC CONDITIONS –PRIOR TO CONSTRUCTION

1. Prior to any construction or impacts authorized by this permit, the Permittee shall provide documentation of the permittee's real property interest over the land upon which the activities subject authorized by this permit will be conducted. The required submittal shall be provided to the Department in a digital format (via electronic mail, CD or DVD, or through file transfer site) when practicable. Interests in real property are defined in Section 4.2.3(d) of Applicant's Handbook Volume I.
2. The reporting address for any submittals required herein for compliance or as a requirement of the General Permit shall be submitted to the Department. Submittals shall be made electronically (via e-mail, CD or DVD, or through a file transfer site) when practicable and shall include the permittee's name and permit number 31-0423078-001-SFG. Email submittals shall be sent to 404_DOT@FloridaDEP.gov with a subject line of "Compliance: permit number 31-0423078-001-SFG", or by mail to:

Department of Environmental Protection
ATTN: Jennipher Walton
3319 Maguire Boulevard
Orlando, Florida 32803

3. Prior to commencement of work authorized by this permit, the permittee shall provide written notification of the date of the commencement and proposed schedule of construction by email to 404_DOT@FloridaDEP.gov or by mail.
4. Prior to construction, the limits of impact shall be clearly marked in a way which is visible and obvious to anyone performing work on-site, including someone operating heavy equipment. Orange construction fencing or tall flagged stakes along the construction limits are possible methods.
5. Prior to initiation of any work authorized by this permit, all wetlands, surface waters, and storm drains, outside the specific limits of construction authorized by this permit shall be protected from erosion, siltation, sedimentation, and/or scouring, including the placement of staked erosion control devices around the project area and staging area(s) that are located outside of any authorized impact areas.
6. Best management practices for erosion control shall be implemented prior to construction commencement and shall be maintained at all times during construction to prevent siltation and turbid discharges in excess of State water quality standards pursuant to Rule 62-302, F.A.C.

Methods shall include, but are not limited to the use of staked hay bales, staked filter cloth, sodding, seeding, staged construction and the installation of turbidity screens around the immediate project site.

SPECIFIC CONDITIONS – CONSTRUCTION ACTIVITIES

7. The limits of construction shall be delineated by silt fencing. The permittee shall bear the responsibility of notifying all construction workers that silt fencing or turbidity barrier represents the limits of all construction activities. The permittee shall bear the responsibility of keeping all construction workers and equipment out of the adjacent wetlands and surface waters where work has not been permitted for impacts.
8. The permittee shall be responsible for ensuring erosion control devices/procedures are inspected and maintained daily during all phases of construction authorized by this permit until areas disturbed during construction are sufficiently stabilized to prevent erosion, siltation, and turbid discharges.
9. This permit authorizes permanent impacts to the wetland fill area shown in the enclosures and exhibits. No other areas are authorized to be impacted, which includes but is not limited to clearing with the use of heavy equipment, filling, or excavation.
10. The permittee shall report any damage to the Department within 24 hours that occurs to the wetlands not authorized for impacts under this permit. If any damage occurs to wetlands or surface waters because of any construction activities, the permittee shall be required to restore the wetland area by regrading the damaged areas back to the natural preconstruction elevations and planting vegetation of the size, densities, and species that exist in the adjacent areas pursuant to a consent order. The restoration shall be completed within 30 days of completion of the construction and shall be done to the satisfaction of the Department.
11. There shall not be any excess lumber, scrap wood, trash, garbage, etc. within wetlands or waters of the State.
12. Construction equipment shall not be repaired or refueled in wetlands or elsewhere within waters of the State.
13. Any fill material used shall be clean fill and free of vegetative matter, trash, garbage, toxic or hazardous waste or any other materials the Department considers unsuitable.
14. The fill and associated side slopes that will be placed on the property shall be stabilized with sod immediately (within 48 hours) following completion of the placement and compaction of the fill material.

SPECIFIC CONDITIONS – HISTORIC ARTIFACTS

15. If prehistoric or historic artifacts, such as pottery or ceramics, projectile points, dugout canoes, metal implements, historic building materials, or any other physical remains that could be associated with Native American, early European, or American settlement are encountered at any

time within the project site area, the permitted project shall cease all activities involving subsurface disturbance in the vicinity of the discovery. The applicant shall contact the Florida Department of State, Division of Historical Resources, Compliance and Review Section at (850)-245-6333. Project activities shall not resume without verbal and/or written authorization. In the event that unmarked human remains are encountered during permitted activities, all work shall stop immediately, and the proper authorities notified in accordance with Section 872.05, Florida Statutes.

SPECIFIC CONDITIONS – LISTED SPECIES

16. The Permittee shall report any injured, sick, or dead federally or state listed animal(s) discovered onsite to the Florida Fish and Wildlife Conservation Commission Wildlife Alert number at 888-404-FWCC (3922).
17. This permit does not authorize the permittee to cause any adverse impact to or “take” of state listed species and other regulated species of fish and wildlife. Compliance with state laws regulating the take of fish and wildlife is the responsibility of the owner or permittee associated with this project. Please refer to Chapter 68A-27 of the Florida Administrative Code for definitions of “take” and a list of fish and wildlife species. If listed species are observed onsite, Florida Fish and Wildlife Conservation Commission (FWC) staff are available to provide decision support information or assist in obtaining the appropriate FWC permits. Most marine endangered and threatened species are statutorily protected and a “take” permit cannot be issued. Requests for further information or review can be sent to ConservationPlanningServices@MyFWC.com.
18. If new information (e.g. listing of new species, new critical habitat, etc.) shows that the magnitude of impacts to federally listed species has the potential for adverse effects, the U.S. Fish and Wildlife Service (USFWS) will notify the Department. The Department will initiate coordination with the permittee and with the USFWS to determine what adverse impacts are likely and if additional minimization measures, reporting, or monitoring are required in order to be consistent with the Endangered Species Act, as deemed necessary by USFWS.

SPECIFIC CONDITIONS – POST-CONSTRUCTION ACTIVITIES

19. Upon final completion of the project and upon reasonable assurance that the project is no longer a potential turbidity source, the permittee will be responsible for the removal of the temporary best management practices and turbidity control devices. All turbidity control devices shall be disposed of in an upland disposal area.
20. Each permittee who receives a general permit verification letter under this Chapter must submit a completed Form 62-331.200(1) – “Certification of Compliance with a State 404 Program General Permit” (effective date), incorporated by reference in subsection 62-331.200(4), F.A.C., within 30 days of completion of the authorized activity, or the implementation of any required compensatory mitigation, whichever is later.

Authority for review – Part IV of Chapter 373, Florida Statutes (F.S.), and Title 62, F.A.C.

Additional Information

Please retain this general permit. The activities may be inspected by authorized state personnel in the future to ensure compliance with appropriate statutes and administrative codes. If the activities are not in compliance, you may be subject to penalties under Chapter 373, F.S., and Chapter 18-14, F.A.C.

NOTICE OF RIGHTS

This action is final and effective on the date filed with the Clerk of the Department unless a petition for an administrative hearing is timely filed under Sections 120.569 and 120.57, F.S., before the deadline for filing a petition. On the filing of a timely and sufficient petition, this action will not be final and effective until further order of the Department. Because the administrative hearing process is designed to formulate final agency action, the subsequent order may modify or take a different position than this action.

Petition for Administrative Hearing

A person whose substantial interests are affected by the Department's action may petition for an administrative proceeding (hearing) under Sections 120.569 and 120.57, F.S. Pursuant to Rules 28-106.201 and 28-106.301, F.A.C., a petition for an administrative hearing must contain the following information:

- (a) The name and address of each agency affected and each agency's file or identification number, if known;
- (b) The name, address, any e-mail address, any facsimile number, and telephone number of the petitioner, if the petitioner is not represented by an attorney or a qualified representative; the name, address, and telephone number of the petitioner's representative, if any, which shall be the address for service purposes during the course of the proceeding; and an explanation of how the petitioner's substantial interests will be affected by the agency determination;
- (c) A statement of when and how the petitioner received notice of the agency decision;
- (d) A statement of all disputed issues of material fact. If there are none, the petition must so indicate;
- (e) A concise statement of the ultimate facts alleged, including the specific facts that the petitioner contends warrant reversal or modification of the agency's proposed action;
- (f) A statement of the specific rules or statutes that the petitioner contends require reversal or modification of the agency's proposed action, including an explanation of how the alleged facts relate to the specific rules or statutes; and
- (g) A statement of the relief sought by the petitioner, stating precisely the action that the petitioner wishes the agency to take with respect to the agency's proposed action.

The petition must be filed (received by the Clerk) in the Office of General Counsel of the Department at 3900 Commonwealth Boulevard, Mail Station 35, Tallahassee, Florida 32399- 3000, or via electronic correspondence at Agency_Clerk@dep.state.fl.us. Also, a copy of the petition shall be mailed to the applicant at the address indicated above at the time of filing.

Time Period for Filing a Petition

In accordance with Rule 62-110.106(3), F.A.C., petitions for an administrative hearing by the applicant and persons entitled to written notice under Section 120.60(3), F.S., must be filed within 21 days of receipt of this written notice. Petitions filed by any persons other than the applicant, and other than those entitled to written notice under Section 120.60(3), F.S., must be filed within 21 days of publication of the notice or within 21 days of receipt of the written notice, whichever occurs first. You cannot justifiably rely on the finality of this decision unless notice of this decision and the right of substantially affected persons to challenge this decision has been duly published or otherwise provided to all persons substantially affected by the decision. While you are not required to publish notice of this action, you may elect to do so pursuant Rule 62- 110.106(10)(a).

The failure to file a petition within the appropriate time period shall constitute a waiver of that person's right to request an administrative determination (hearing) under Sections 120.569 and 120.57, F.S., or to intervene in this proceeding and participate as a party to it. Any subsequent intervention (in a proceeding initiated by another party) will be only at the discretion of the presiding officer upon the filing of a motion in compliance with Rule 28-106.205, F.A.C. If you do not publish notice of this action, this waiver will not apply to persons who have not received written notice of this action.

Extension of Time

Under Rule 62-110.106(4), F.A.C., a person whose substantial interests are affected by the Department's action may also request an extension of time to file a petition for an administrative hearing. The Department may, for good cause shown, grant the request for an extension of time. Requests for extension of time must be filed with the Office of General Counsel of the Department at 3900 Commonwealth Boulevard, Mail Station 35, Tallahassee, Florida 32399- 3000, or via electronic correspondence at Agency_Clerk@dep.state.fl.us, before the deadline for filing a petition for an administrative hearing. A timely request for extension of time shall toll the running of the time period for filing a petition until the request is acted upon.

Mediation

Mediation is not available in this proceeding.

FLAWAC Review

The applicant, or any party within the meaning of Section 373.114(1)(a) or 373.4275, F.S., may also seek appellate review of this order before the Land and Water Adjudicatory Commission under Section 373.114(1) or 373.4275, F.S. Requests for review before the Land and Water Adjudicatory Commission must be filed with the Secretary of the Commission and served on the Department within 20 days from the date when this order is filed with the Clerk of the Department.

Judicial Review

Once this decision becomes final, any party to this action has the right to seek judicial review pursuant to Section 120.68, F.S., by filing a Notice of Appeal pursuant to Florida Rules of Appellate Procedure 9.110 and 9.190 with the Clerk of the Department in the Office of General Counsel (Station #35, 3900 Commonwealth Boulevard, Tallahassee, Florida 32399-3000) and by filing a copy of the Notice of Appeal accompanied by the applicable filing fees with the appropriate district court of appeal. The notice must be filed within 30 days from the date this action is filed with the Clerk of the Department.

EXECUTION AND CLERKING

Executed in West Palm Beach, Florida.

STATE OF FLORIDA DEPARTMENT OF ENVIRONMENTAL PROTECTION



Timothy Rach
Program Administrator
Submerged Lands & Environmental Resources Coordination
Division of Water Resource Management

Enclosures:

General Permit for Outfall and Intake Structures, Ch. 62-331.214, F.A.C.
General Conditions for All General Permits, Ch. 62-331.201, F.A.C.
Project drawings, 30 pages
Certification of Compliance with State 404 Program General Permit, [form 62-331.200\(1\)](#)

CERTIFICATE OF SERVICE

The undersigned duly designated deputy clerk hereby certifies that this document and all attachments were sent on the filing date below to the following listed persons:

FDEP: Lindsay Furr, Jennipher Walton, Allan Popak
U.S. Environmental Protection Agency, State404FinalPermits-Florida@epa.gov
James Mann, Indian River County Government, jmann@ircgov.com
James Poole, FDOT, James.Poole@dot.state.fl.us
Fernando Ascanio, FDOT, Fernando.Ascanio@dot.state.fl.us
Rupa Magar-Chhabra, FDOT, Rupa.Magar-Chhabra@dot.state.fl.us
Ann Broadwell, FDOT, Ann.Broadwell@dot.state.fl.us
George Kulczycki, G.K. Environmental, GKE@ME.com
Todd Howder, MBV Engineering, Inc., toddh@mbveng.com
Aaron Stanton, MBV Engineering, Inc., aarons@mbveng.com

FILING AND ACKNOWLEDGMENT

FILED, on this date, pursuant to Section 120.52, F. S., with the designated Department Clerk, receipt of which is hereby acknowledged.

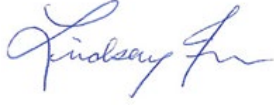

March 10, 2023

Clerk

Date

62-331.214 General Permit for Outfall and Intake Structures.

(1) This general permit authorizes activities related to the construction or modification of outfall structures and associated intake structures, where the effluent from the outfall is authorized, conditionally authorized, or specifically exempted by, or otherwise in compliance with regulations issued under Part I of Chapter 403, F.S.

(2) This general permit does not authorize the construction of intake structures, unless they are directly associated with an authorized outfall structure.

(3) Notification: The permittee must submit a notice to the Agency prior to commencing the activity.

Rulemaking Authority 373.026(7), 373.043, 373.118(1), 373.4131, 373.414(9), 373.4145, 373.4146(2), 403.805(1) FS. Law Implemented 373.118, 373.129, 373.136, 373.413, 373.4131, 373.414, 373.4145, 373.4146, 373.416, 373.422, 373.423, 373.429 FS. History—New 12-22-20.

Conditions for General Permits – Rule 62-331.201, F.A.C.

(1) General permits shall be subject to the conditions in subsections (2) and (3), below, and the general conditions for all general permits in Rule 62-330.405, F.A.C., except subsections 62-330.405(7) and (10), F.A.C. The Agency may revise the general conditions in Rule 62-330.405, F.A.C. to include references to applicable rules under this Chapter, as necessary.

(2) When a project requires submittal of a notice of intent to use a general permit, the Agency shall impose specific conditions as necessary to assure that the activities will be conducted in compliance with this Chapter, and in a manner which minimizes adverse impacts upon the physical, chemical, and biological integrity of wetlands or other surface waters, such as mitigation, monitoring, reporting, or recordkeeping requirements and protection measures for listed species or historical resources.

(3) In addition, general permits under this Chapter are subject to the following conditions:

(a) Aquatic Life Movements. No activity may substantially disrupt the necessary life cycle movements of those species of aquatic life indigenous to the waterbody, including those species that normally migrate through the area, unless the activity's primary purpose is to impound water. All permanent and temporary crossings of waterbodies shall be suitably culverted, bridged, or otherwise designed and constructed to maintain low flows to sustain the movement of those aquatic species. If a bottomless culvert cannot be used, then the crossing shall be designed and constructed to minimize adverse effects to aquatic life movements.

(b) Spawning Areas. Activities in spawning areas during spawning seasons must be avoided to the maximum extent practicable. Activities that result in the physical destruction (e.g., through excavation, fill, or downstream smothering by substantial turbidity) of an important spawning area are not authorized.

(c) Migratory Bird Breeding Areas. Activities in state-assumed waters that serve as breeding areas for migratory birds must be avoided to the maximum extent practicable.

(d) Shellfish Beds. No activity may occur in areas of concentrated shellfish populations, unless the activity is directly related to a shellfish harvesting activity authorized by general permits in Rule 62-331.211 or 62-331.244, F.A.C., or is a shellfish seeding or habitat restoration activity authorized by the general permit in Rule 62-331.225, F.A.C.

(e) Suitable Material. No activity may use unsuitable material (e.g., trash, debris, car bodies, asphalt, etc.). Material used for construction or fill must be free from toxic pollutants in toxic amounts as listed in section 307 of the CWA, which is incorporated by reference in subparagraph 62-331.053(3)(a)3., F.A.C., or state law.

(f) Water Supply Intakes. No activity may occur within 1000 feet of a public water supply intake, except where the activity is for the repair or improvement of public water supply intake structures or adjacent bank stabilization.

(g) Fills Within 100-year Floodplains. The activity shall comply with applicable FEMA-approved state or local floodplain management requirements.

(h) Single and Complete Project. The activity must be a single and complete project. The same general permit cannot be used more than once for the same single and complete project unless otherwise stated within the general permit. (See 404 Handbook, section 3.2.1).

(i) Wild and Scenic Rivers. No general permit activity may occur in a component of the National Wild and Scenic Rivers System, or in a river officially designated by Congress as a study river for possible inclusion in the System while the river is in an official study status, unless the appropriate federal agency with direct management responsibility for such river has determined in writing that the proposed activity will not adversely affect the Wild and Scenic River designation or study status.

(j) Tribal Rights. No general permit activity may cause more than minimal adverse effects on tribal rights (including treaty rights, settlement rights, or rights reserved under state or federal law), protected tribal resources (including cultural or burial resources off reservation), tribal waters, or to tribal lands.

(k) Listed species. No activity is authorized under any general permit which is likely to directly or indirectly jeopardize the continued existence of an endangered or threatened species or a species proposed for such designation, or which will directly or indirectly destroy or adversely modify the critical habitat of such species. No activity is authorized under any general permit which may affect a listed species or critical habitat, unless the Agency has consulted with, or been provided technical assistance by the Florida Fish & Wildlife Conservation Commission, the U.S. Fish & Wildlife Service, and the National Marine Fisheries Service under their respective authorities and appropriate measures to address the effects of the proposed activity have been implemented or are required as a specific condition to the general permit.

(l) Migratory Birds and Bald and Golden Eagles. The permittee is responsible for ensuring their action complies with the Migratory Bird Treaty Act, 16 U.S.C. §§ 703 – 712 (2018), incorporated by reference herein (<https://www.flrules.org/Gateway/reference.asp?No=Ref-12068>), and the Bald and Golden Eagle Protection Act, 16 U.S.C. §§ 668 – 668(d) (2018), incorporated by reference herein (<https://www.flrules.org/Gateway/reference.asp?No=Ref-12069>). The permittee is responsible for contacting the appropriate local office of the U.S. Fish and Wildlife Service to determine applicable measures to reduce impacts to migratory birds or eagles, including whether incidental take permits are necessary and available under the Migratory Bird Treaty Act or Bald and Golden Eagle Protection Act for a particular activity.

(m) Historic Properties. In cases where the Agency determines, based on information from SHPO, that the activity may have the potential to cause effects to properties listed, or eligible for listing, in the National Register of Historic Places, the activity is not authorized until a determination of “no effect” or “no adverse effect” is provided by SHPO.

(n) Manatees. In waters that are accessible to manatees, the permittee shall follow the “Standard Manatee Conditions for In-Water Work (2011)”, incorporated by reference herein (<https://www.flrules.org/Gateway/reference.asp?No=Ref-12070>).

(o) Sea turtles, smalltooth sawfish, Gulf sturgeon, or shortnose sturgeon. In waters that are accessible to these species, the permittee shall follow the “Sea Turtle and Smalltooth Sawfish Construction Conditions” (March 23, 2006), incorporated by reference herein (<https://www.flrules.org/Gateway/reference.asp?No=Ref-12071>).

(p) Use of Multiple General Permits. The use of more than one general permit under this Chapter for a single and complete project is prohibited, except when specified within a specific general permit, or when the acreage loss of state-assumed waters authorized by the general permits does not exceed the acreage limit of the general permit with the highest specified acreage limit.

(q) Transfer of General Permit Verifications. If the permittee sells the property associated with the general permit verification, the permittee shall transfer the general permit verification to the new owner by submitting a completed Form 62-331.100(1) – “Transfer of State 404 Program General Permit Verification” (effective date), incorporated by reference in subsection 62-331.100(2), F.A.C., within 30 days of the sale, to the Agency that processed the original notice.

(r) Compliance Certification. Each permittee who receives a general permit verification letter under this Chapter must submit a completed Form 62-331.200(1) – “Certification of Compliance with a State 404 Program General Permit” (effective date), incorporated by reference in subsection 62-331.200(4), F.A.C., within 30 days of completion of the authorized activity, or the implementation of any required compensatory mitigation, whichever is later.

(s) Activities Affecting Structures or Work Built by the United States. If an activity also requires permission from the Corps pursuant to 33 U.S.C. § 408 because it will alter or temporarily or permanently occupy or use a Corps federally authorized Civil Works project, the prospective permittee is responsible for obtaining such permission separately from the Corps prior to commencing activities authorized by the general permit.

(t) If during the ground disturbing activities and construction work within the permit area, there are archaeological or cultural materials encountered which were not the subject of a previous cultural resources assessment survey or to which such impacts were not anticipated, including but not limited to pottery, modified shell, flora, fauna, human remains, ceramics, stone tools or metal implements, dugout canoes, evidence of structures or any other physical remains that could be associated with Native American cultures or early colonial or American settlement; the Permittee shall immediately stop all work and ground-disturbing activities within a 100-meter diameter of the discovery and notify the Agency within the same business day. The Agency shall then notify the State Historic Preservation Officer (SHPO) and the appropriate Tribal Historic Preservation Officer(s) (THPO(s)) or tribe when the interested tribe does not have a THPO, to assess the significance of the discovery and devise appropriate actions.

(u) Additional cultural resources assessments may be required of the permit area in the case of unanticipated discoveries or effects to historic properties as referenced in accordance with

condition (t), above, and if deemed necessary by the SHPO, or THPO(s), Tribes, or Agency. Based on the circumstances of the discovery, equity to all parties, and considerations of the public interest, the Agency may modify, suspend, or revoke the permit in accordance with Rule 62-331.080, F.A.C. Such activity shall not resume without written authorization from the SHPO and THPO(s), or tribe when the interested tribe does not have a THPO, concerning potential effects to cultural resources or historic properties for finds under their jurisdiction, and from the Agency.

(v) In the event that unmarked human remains are identified, they shall be treated in accordance with Section 872.05, F.S. All work and ground-disturbing activities within a 100-meter diameter of the unmarked human remains shall immediately cease and the Permittee shall immediately notify the medical examiner, Agency, and State Archaeologist within the same business day. The Agency shall then notify the appropriate SHPO and THPO(s) and appropriate tribes and other appropriate consulting parties. Based on the circumstances of the discovery, equity to all parties, and considerations of the public interest, the Agency may modify, suspend, or revoke the permit in accordance with Rule 62-331.080, F.A.C. Such activity shall not resume without written authorization from the medical examiner, State Archaeologist, and from the Agency. Additionally, if the unmarked remains were identified on federal lands, or lands where the Archaeological Resources Protection Act, 16 U.S.C. §§ 470aa – 470mm (2018), incorporated by reference herein (<https://www.flrules.org/Gateway/reference.asp?No=Ref-12072>), or the Native American Graves Protection and Repatriation Act, 25 U.S.C. §§ 3001-3013 (2018), incorporated by reference herein (<https://www.flrules.org/Gateway/reference.asp?No=Ref-12073>), applies, such activity shall not resume without written authorization from the SHPO, the appropriate THPO(s), and the federal land manager.

(w) Noncompliance. The permittee shall timely notify the Agency of any expected or known actual noncompliance.

(x) Inspection and entry. The permittee shall allow the Agency, upon presentation of proper identification, at reasonable times to:

1. Enter upon the permittee's premises where a regulated activity is located or where records must be kept under the conditions of the permit,
2. Have access to and copy any records that must be kept under the conditions of the permit,
3. Inspect operations regulated or required under the permit, and
4. Sample or monitor, for the purposes of assuring permit compliance or as otherwise authorized by the Act, any substances or parameters at any location.

(y) The permittee shall comply with all conditions of the permit, even if that requires halting or reducing the permitted activity to maintain compliance. Any permit violation constitutes a violation of Part IV of Chapter 373, F.S., and this Chapter, as well as a violation of the CWA.

(z) The permittee shall take all reasonable steps to prevent any unauthorized dredging or filling in violation of this permit.

(aa) Upon Agency request, the permittee shall provide information necessary to determine compliance status, or whether cause exists for permit modification, revocation, or termination.

Rulemaking Authority 373.026(7), 373.043, 373.118(1), 373.4131, 373.414(9), 373.4145, 373.4146(2), 403.805(1) FS. Law Implemented 373.118, 373.129, 373.136, 373.413, 373.4131, 373.414, 373.4145, 373.4146, 373.416, 373.422, 373.423, 373.429 FS. History – New 12.22.2020.

62-330.405 General Conditions for All General Permits.

The following general permit conditions are binding upon the permittee and are enforceable under chapter 373, F.S. These conditions do not apply to the general permit for stormwater management systems under section 403.814(12), F.S

(1) The general permit is valid only for the specific activity indicated. Any deviation from the specified activity and the conditions for undertaking that activity shall constitute a violation of the permit and may subject the permittee to enforcement action and revocation of the permit under chapter 373, F.S

(2) The general permit does not eliminate the necessity to obtain any required federal, state, local and special district authorizations prior to the start of any construction, alteration, operation, maintenance, removal or abandonment authorized by this permit; and it does not authorize any violation of any other applicable federal, state, local, or special district laws (including, but not limited to, those governing the “take” of listed species).

(3) The general permit does not convey to the permittee or create in the permittee any property right, or any interest in real property, nor does it authorize any entrance upon or activities on property which is not owned or controlled by the permittee, or convey any rights or privileges other than those specified in the general permit.

(4) The general permit does not relieve the permittee from liability and penalties when the permitted activity causes harm or injury to: human health or welfare; animal, plant or aquatic life; or property. It does not allow the permittee to cause pollution that violates state water quality standards.

(5) Section 253.77, F.S., provides that a person may not commence any excavation, construction, or other activity involving the use of state-owned or other lands of the state, the title to which is vested in the Board of Trustees of the Internal Improvement Trust Fund without obtaining the required consent, lease, easement, or other form of authorization authorizing the proposed use. Therefore, the permittee is responsible for obtaining any necessary authorizations from the Board of Trustees prior to commencing activity on state-owned lands.

(6) The authorization to conduct activities under a general permit may be modified, suspended or revoked in accordance with chapter 120, F.S., and section 373.429, F.S.

(7) Not applicable.

(8) Upon reasonable notice to the permittee, Agency staff with proper identification shall have permission to enter, inspect, sample and test the permitted system to ensure conformity with the plans and specifications approved by the general permit.

(9) The permittee shall maintain any permitted project or activity in accordance with the plans

submitted to the Agency and authorized in the general permit.

(10) Not applicable.

(11) Activities shall be conducted in a manner that does not cause or contribute to violations of state water quality standards. Performance-based erosion and sediment control best management practices shall be implemented and maintained immediately prior to, during, and after construction as needed to stabilize all disturbed areas, including other measures specified in the permit to prevent adverse impacts to the water resources and adjacent lands. Erosion and sediment control measures shall be installed and maintained in accordance with the *State of Florida Erosion and Sediment Control Designer and Reviewer Manual (Florida Department of Environmental Protection and Florida Department of Transportation, June 2007)*, available at <https://www.flrules.org/Gateway/reference.asp?No=Ref-04227>, and the *Florida Stormwater Erosion and Sedimentation Control Inspector's Manual (Florida Department of Environmental Protection, Nonpoint Source Management Section, Tallahassee, Florida, July 2008)*, available at http://publicfiles.dep.state.fl.us/DEAR/Stormwater_Training_Docs/erosion-inspectors-manual.pdf.

(12) Unless otherwise specified in the general permit, temporary vehicular access within wetlands during construction shall be performed using vehicles generating minimum ground pressure to minimize rutting and other environmental impacts. Within forested wetlands, the permittee shall choose alignments that minimize the destruction of mature wetland trees to the greatest extent practicable. When needed to prevent rutting or soil compaction, access vehicles shall be operated on wooden, composite, metal, or other non-earthen construction mats. In all cases, access in wetlands shall comply with the following:

(a) Access within forested wetlands shall not include the cutting or clearing of any native wetland tree having a diameter four inches or greater at breast height;

(b) The maximum width of the construction access area shall be limited to 15 feet;

(c) All mats shall be removed as soon as practicable after equipment has completed passage through, or work has been completed, at any location along the alignment of the project, but in no case longer than seven days after equipment has completed work or passage through that location; and

(d) Areas disturbed for access shall be restored to natural grades immediately after the maintenance or repair is completed.

(13) Barges or other work vessels used to conduct in-water activities shall be operated in a manner that prevents unauthorized dredging, water quality violations, and damage to submerged aquatic communities.

(14) The construction, alteration, or use of the authorized project shall not adversely impede navigation or create a navigational hazard in the water body.

(15) Except where specifically authorized in the general permit, activities must not:

(a) Impound or obstruct existing water flow, cause adverse impacts to existing surface water storage and conveyance capabilities, or otherwise cause adverse water quantity or flooding impacts to receiving water and adjacent lands; or

(b) Cause an adverse impact to the maintenance of surface or ground water levels or surface water flows established pursuant to section 373.042, F.S., or a Works of the District established pursuant to section 373.086, F.S.

(16) If prehistoric or historic artifacts, such as pottery or ceramics, projectile points, stone tools, dugout canoes, metal implements, historic building materials, or any other physical remains that could be associated with Native American, early European, or American settlement are encountered at any time within the project site area, the permitted project shall cease all activities involving subsurface disturbance in the vicinity of the discovery. The permittee or other designee shall contact the Florida Department of State, Division of Historical Resources, Compliance Review Section (DHR), at (850)245-6333, as well as the appropriate permitting agency office. Project activities shall not resume without verbal or written authorization from the Division of Historical Resources. If unmarked human remains are encountered, all work shall stop immediately and the proper authorities notified in accordance with section 872.05, F.S.

(17) The activity must be capable, based on generally accepted engineering and scientific principles, of being performed and of functioning as proposed, and must comply with any applicable District special basin and geographic area criteria.

(18) The permittee shall comply with the following when performing work within waters accessible to federally- or state-listed aquatic species, such as manatees, marine turtles, smalltooth sawfish, and Gulf sturgeon:

(a) All vessels associated with the project shall operate at "Idle Speed/No Wake" at all times while in the work area and where the draft of the vessels provides less than a four-foot clearance from the bottom. All vessels will follow routes of deep water whenever possible.

(b) All deployed siltation or turbidity barriers shall be properly secured, monitored, and maintained to prevent entanglement or entrapment of listed species.

(c) All in-water activities, including vessel operation, must be shut down if a listed species comes within 50 feet of the work area. Activities shall not resume until the animal(s) has moved beyond a 50-foot radius of the in-water work, or until 30 minutes elapses since the last sighting within 50 feet. Animals must not be herded away or harassed into leaving. All onsite project personnel are responsible for observing water-related activities for the presence of listed species.

(d) Any listed species that is killed or injured by work associated with activities performed shall be reported immediately to the Florida Fish and Wildlife Conservation Commission (FWC) Hotline at 1(888)404-3922 and ImperiledSpecies@myFWC.com.

(e) Whenever there is a spill or frac-out of drilling fluid into waters accessible to the above species during a directional drilling operation, the FWC shall be notified at ImperiledSpecies@myfwc.com with details of the event within 24 hours following detection of the spill or frac-out.

(19) The permittee shall hold and save the Agency harmless from any and all damages, claims, or liabilities which may arise by reason of the construction, alteration, operation, maintenance, removal, abandonment or use of any activity authorized by the general permit.

(20) The permittee shall immediately notify the Agency in writing of any submitted information that is discovered to be inaccurate.

Rulemaking Authority 373.026(7), 373.043, 373.118(1), 373.406(5), 373.4131, 373.414(9), 373.4145, 373.418, 403.805(1) FS. Law Implemented 373.044, 373.118(1), 373.129, 373.136, 373.406(5), 373.413, 373.4131, 373.414(9), 373.4145, 373.416, 373.422, 373.423, 373.429, 403.814(1) FS. History—New 10-3-95, Amended 10-1-07, Formerly 62-341.215, Amended 10-1-13, 6-1-18.

INDIAN RIVER COUNTY BOARD OF COUNTY COMMISSIONERS

CONTRACT PLANS

RAILS TO TRAILS 1.4 MILE EXTENSION OF
THE HISTORIC TRANS-FLORIDA RAIL TRAIL

FDOT FM# 446073-1-58-01

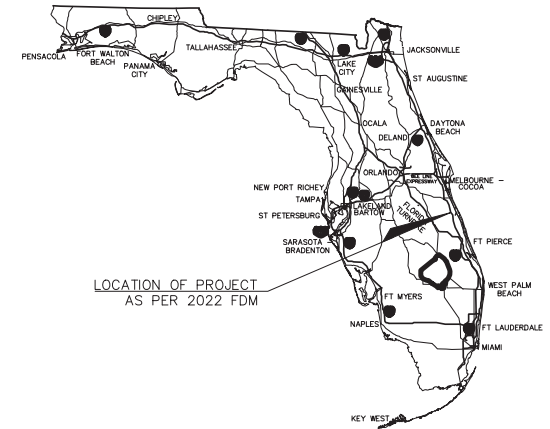

INDEX OF ROADWAY PLANS	
SHEET NO.	SHEET DESCRIPTION
C1	KEY SHEET
C2	REVISIONS TABLE
C3	SIGNATURE SHEET
C4	SUMMARY OF QUANTITIES, PAY ITEMS & DRAINAGE PIPES
C5	TYPICAL SECTION
C6	WETLAND RE-HYDRATION CULVERT SECTIONS
C7	WETLAND RE-HYDRATION CULVERT SECTION AND
C8	PIPE INSTALLATION DETAILS
C9	GENERAL NOTES
C10	SITE SIGNAGE AND DETAILS
C11-C15	SITE PLAN WITH AERIAL OVERLAY
C16	EROSION CONTROL DETAILS
C17	DEMOLITION PLAN
C18-C30	PLAN & PROFILE SHEETS

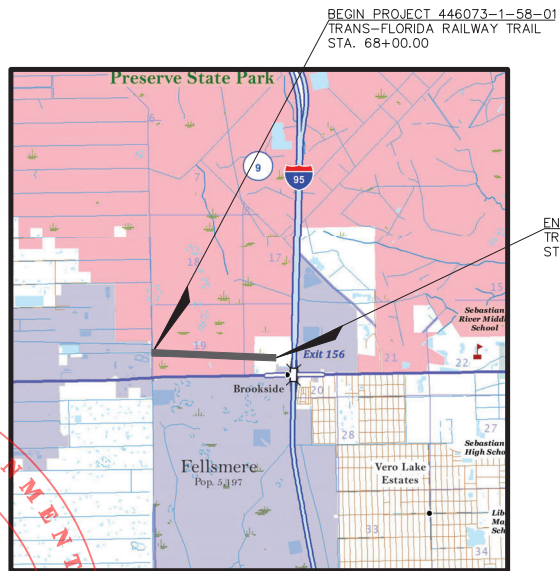

END PROJECT 446073-1-58-01
TRANS-FLORIDA RAILWAY TRAIL
STA. 141+15.04

BEGIN PROJECT 446073-1-58-01
TRANS-FLORIDA RAILWAY TRAIL
STA. 68+00.00



This item has been digitally signed & sealed by Aaron Stanton, P.E. on the date adjacent to the seal.
Printed copies of this document are not considered signed & sealed and the signature must be verified on any electronic copies.



I.R.C. PROJECT MANAGERS:
METROPOLITAN PLANNING ORGANIZATION:
MPO STAFF DIRECTOR:
BRIAN FREEMAN - 772-226-1455
1801 27th STREET
VERO BEACH, FL 32960-3388
Civil Engineer

FDOT
CONSTRUCTABILITY
SUBMITTAL:
JUNE, 2022

REVISED: AUGUST 2022
REVISED: SEPTEMBER 2022

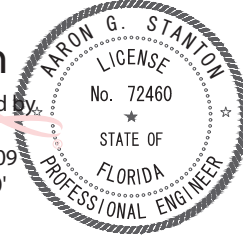

Aaron Stanton

Digitally signed by: Aaron Stanton

Date: 2022.09.09

13:37:01 -04'00'

COUNTY COMMISSIONERS:

- SUSAN ADAMS, COMMISSIONER, DISTRICT 1
- JOSEPH E. FLESCHER, COMMISSIONER, DISTRICT 2
- JOE EARMAN, VICE-CHAIRMAN, DISTRICT 3
- PETER D. O'BRYAN, CHAIRMAN, DISTRICT 4
- LAURA MOSS, COMMISSIONER, DISTRICT 5

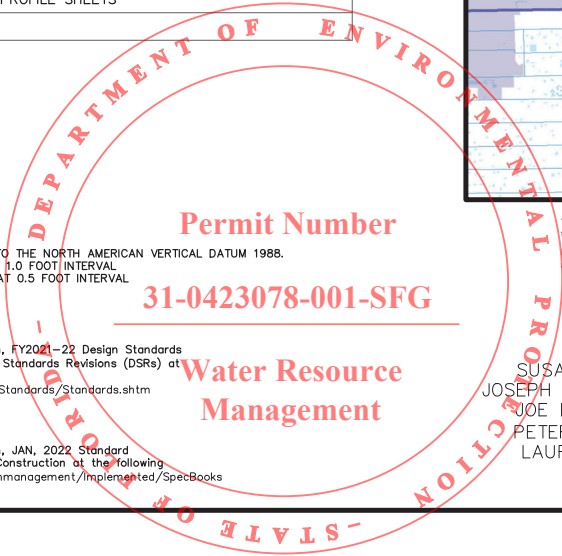

ELEVATIONS SHOWN HEREIN REFER TO THE NORTH AMERICAN VERTICAL DATUM 1988.
EXISTING CONTOURS SHOWN AT 1.0 FOOT INTERVAL
PROPOSED CONTOURS SHOWN AT 0.5 FOOT INTERVAL

Florida Department of Transportation, FY2021-22 Design Standards eBook (DSeB) and applicable Design Standards Revisions (DSRs) at the following website:
<http://www.fdot.gov/roadway/DesignStandards/Standards.shtm>
APPLICABLE DSRs:

Florida Department of Transportation, JAN, 2022 Standard Specifications for Road and Bridge Construction at the following website:
<http://www.fdot.gov/programmanagement/Implemented/SpecBooks>

CONSTRUCTION CONTRACT NO.	FISCAL YEAR	SHEET NO.
-	22	C1

THE OFFICIAL RECORD OF THIS SHEET IS THE ELECTRONIC FILE DIGITALLY SIGNED AND SEALED UNDER RULE 61G15-23.004 F.A.C.

1. REVISIONS TO SHEETS C24 AND C25 TO REMOVE PREVIOUSLY DEPICTED WETLAND IMPACTS AND SHIFT TRAIL NORTH IN THIS AREA.
2. REVISIONS TO SHEETS C9 TO ADD FDEP TEMPORARY FILL DIRECTIVE TO THE CONTRACTOR IF APPLICABLE.



REVISIONS	DATE	JOB NO.
△		21-0311
---		DESIGNED TH
---		DRAWN SS
---		DATE DEC. 2021
---		CHECKED AS
△ PER FDEP RAI #1 COMMENTS	09/09/2022	
△ PER SJRWMD FIELD INSPECTION	08/23/2022	DATE ISSUED 08/11/2022



1835 20TH STREET
 VERO BEACH, FL 32960
 PH. (772) 569-0035
 FX. (772) 778-3617

MELBOURNE, FL - PH (321) 253-1510
 FT. PIERCE, FL - PH (772) 468-8055

HISTORIC TRANS-FLORIDA RAIL
 TRAIL PHASE 2 EXTENSION

INDIAN RIVER COUNTY FLORIDA

REVISIONS TABLE

SHEET
C2
 DATE: 21-0311

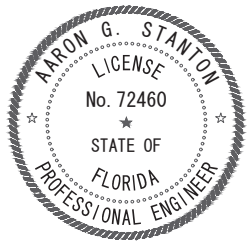

MBV ENGINEERING, INC.
 1835 20th STREET
 VERO BEACH, FL 32960
 CERTIFICATE OF AUTHORIZATION 3728

THE ABOVE NAMED PROFESSIONAL ENGINEER SHALL BE RESPONSIBLE FOR THE FOLLOWING SHEETS IN ACCORDANCE WITH RULE 61G15-23.004, F.A.C.



INDIAN RIVER COUNTY
 PUBLIC WORKS DEPARTMENT
 SURVEY SECTION
 1801 27th STREET
 VERO BEACH, FL 32960
 FLORIDA CERTIFICATE No. 6139

THE ABOVE NAMED PROFESSIONAL SURVEYOR AND MAPPER SHALL BE RESPONSIBLE FOR THE FOLLOWING SHEETS: Existing Conditions Survey and Easement Documents.



REVISIONS	DATE

JOB NO.	21-0311
DESIGNED	TH
DRAWN	SS
DATE	DEC. 2021
CHECKED	AS
DATE ISSUED	08/11/2022



1835 20TH STREET
 VERO BEACH, FL 32960
 PH. (772) 569-0035
 FX. (772) 778-3617

MELBOURNE, FL - PH (321) 253-1510
 FT. PIERCE, FL - PH (772) 468-8055

HISTORIC TRANS-FLORIDA RAIL
 TRAIL PHASE 2 EXTENSION

INDIAN RIVER COUNTY FLORIDA

SIGNATURE SHEET

DATE: _____

SHEET
C3
 21-0311

SUMMARY OF PAY ITEMS:

- 110-1-1 THIS PROJECT WILL REQUIRE REMOVAL OF EXISTING ASPHALT MILLINGS AND SEMI-FLEXIBLE PAVEMENT FROM STA 127+04.10 TO STA 141+15.04. REMOVAL AND DISPOSAL SHALL BE INCLUDED UNDER THIS PAY ITEM.

- 700-1-11 INDIAN RIVER COUNTY SHALL PRODUCE SCRUB JAY SIGN GRAPHIC AND SIGN POST ASSEMBLY. CONTRACTOR SHALL BE RESPONSIBLE FOR INSTALLATION AS DEPICTED ON APPROVED PLANS OR AS DIRECTED BY PARK PRESERVE STAFF.

- 519-78 CONTRACTOR SHALL INCLUDE MATERIAL COSTS AND INSTALLATION OF COLLAPSIBLE BOLLARDS. COLLAPSIBLE BOLLARD SHALL BE PER SPECIFICATION AS NOTED IN THE CONTRACT DOCUMENT, OR APPROVED EQUAL UPON REVIEW AND APPROVAL OF APPROVED EQUUAL BY IRC STAFF AND ENGINEER OF RECORD.

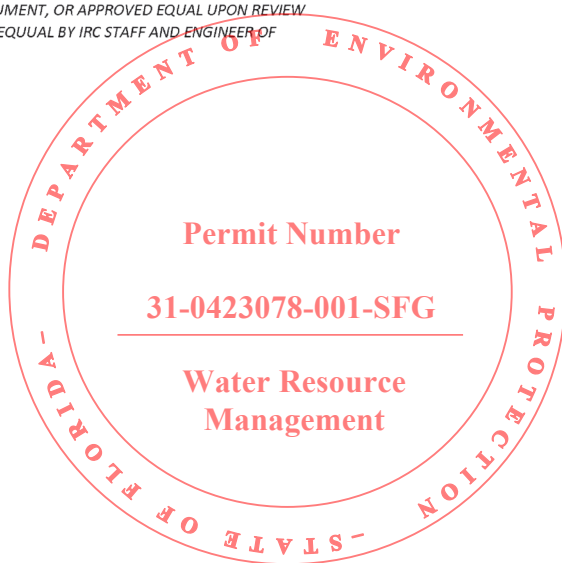

PAY ITEM NO.	DESCRIPTION	UNIT	PROJECT QUANTITY
ROADWAY PAY ITEMS			
101-1	MOBILIZATION	LS	1
102-1	MAINTENANCE OF TRAFFIC	LS	1
104-1	ARTIFICIAL COVERINGS / EROSION CONTROL ABATEMENT PRODUCTS	SY	8,150
104-10-3	SEDIMENT BARRIER	LF	14,800
104-15	SOIL TRACKING PREVENTION DEVICE	EA	2
110-1-1	CLEARING AND GRUBBING	AC	4.50
120-1	REGULAR EXCAVATION	CY	10
120-6	EMBANKMENT	CY	2,650
160-4	TYPE B STABILIZATION 12" (LBR-40)	SY	13,000
285-704	OPTIONAL BASE GROUP 4 (6" CEMENTED COQUINA) (LBR 100)	SY	10,250
285-706	OPTIONAL BASE GROUP 6 (8" CEMENTED COQUINA) (LBR 100)	SY	300
334-1-12	SUPERPAVE ASPHALT CONCRETE, TRAFFIC B (TYPE SP-9.5, 1.5")	TN	790
334-1-13	SUPERPAVE ASPHALT CONCRETE, TRAFFIC C (TYPE SP-9.5, 1") (FPL EASEMENT AREA)	TN	14
334-1-13	SUPERPAVE ASPHALT CONCRETE, TRAFFIC C (TYPE SP-12.5, 1.5") (FPL EASEMENT AREA)	TN	21
430-175-115	PIPE CULVERT, OPTIONAL MATERIAL, ROUND, 15" S/CD (RCP)	LF	24
430-175-124	PIPE CULVERT, OPTIONAL MATERIAL, ROUND, 24" S/CD (RCP)	LF	80
430-175-224	PIPE CULVERT, OPTIONAL MATERIAL, ROUND, 19"x30" S/CD (ERCP)	LF	40
570-1-2	PERFORMANCE TURF, SOD (MATCH EXISTING)	SY	6,450
700-1-11	SCRUB JAY TRAIL SIGNAGE (INSTALLATION ONLY)	AS	2
700-1-11	SINGLE OST SIGN, UP TO 12 SF	AS	1
519-78	BOLLARDS (COLLAPSIBLE)	EA	4

LS = Lump Sum DA = Day LF = Linear Foot AC = Acre SY = Square Yard CY = Cubic Yard TN = Ton
 EA = Each AS = Assembly GM = Gross Mile PI = Per Intersection

SUMMARY OF DRAINAGE PIPES

MARK	STATION	DESCRIPTION	SIZE	LENGTH	START PIPE	START INVERT	END PIPE	END INVERT
#1	68+23.93	RCP	15"	24 LF	10.11 RIGHT	25.00	13.89 RIGHT	25.00
#2	73+71.68	RCP	24"	40 LF	18.57 RIGHT	25.00	21.43 RIGHT	25.00
#3	83+09.52	RCP	24"	40 LF	19.90 RIGHT	26.40	20.10 LEFT	26.40
#4	141+00.0	ERCP	19"x30"	40 LF	17.11 RIGHT	22.50	22.89 LEFT	22.50

REVISIONS	DATE	JOB NO.
DESIGNED		21-0311
DRAWN		
CHECKED		
DATE	DEC. 2021	
CHECKED		AS
PER FDEP RAI #1 COMMENTS	09/09/2022	
PER SJRWMD FIELD INSPECTION	08/23/2022	
DATE ISSUED	08/11/2022	



1835 20TH STREET
 VERO BEACH, FL 32960
 PH. (772) 569-0035
 FX. (772) 778-3617
 MELBOURNE, FL - PH (321) 253-1510
 FT. PIERCE, FL - PH (772) 468-8065

INDIAN RIVER COUNTY

HISTORIC TRANS-FLORIDA RAIL
 TRAIL PHASE 2 EXTENSION

FLORIDA

SUMMARY OF QUANTITIES,
 PAY ITEMS AND DRAINAGE PIPES

DATE:

SHEET

C4

21-0311

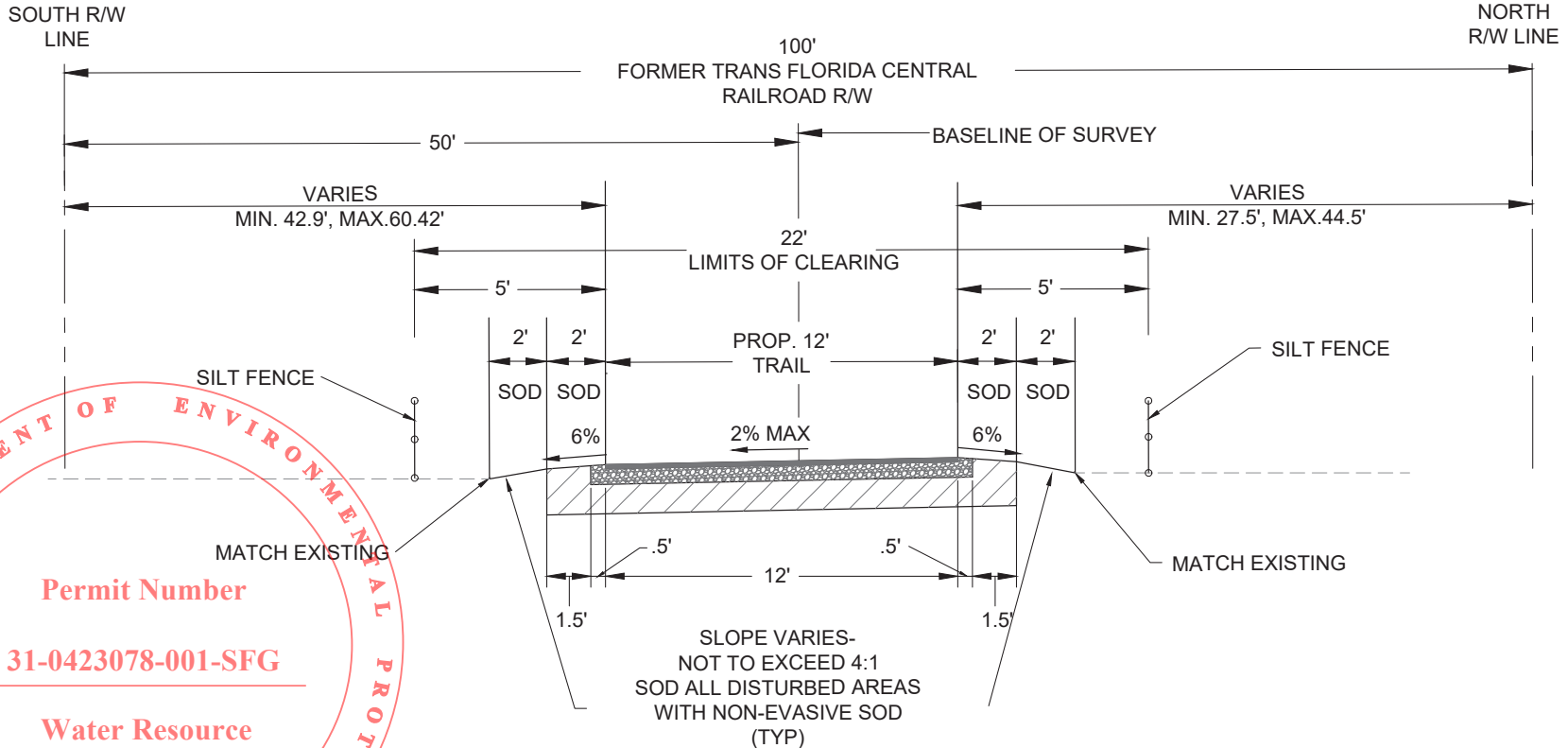

DEPARTMENT OF ENVIRONMENTAL PROTECTION
STATE OF FLORIDA
 Permit Number
31-0423078-001-SFG
 Water Resource Management

TYPICAL TRAIL SECTION

N.T.S.

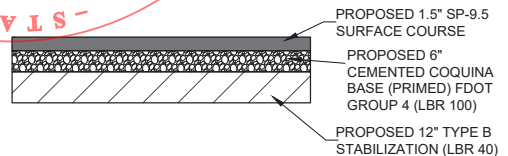

TYPICAL TRAIL STRUCTURAL SECTION

N.T.S.

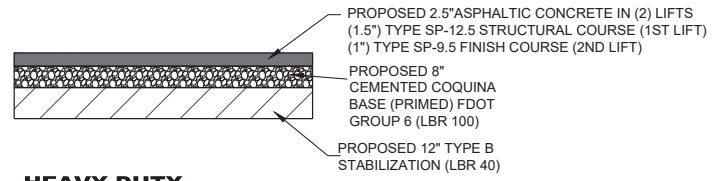

HEAVY DUTY TYPICAL TRAIL STRUCTURAL SECTION
STA. 95+08.70 TO STA. 96+96.02

N.T.S.

REVISIONS	DATE	JOB NO.
		21-0311
		DESIGNED TH
		DRAWN SS
		DATE DEC. 2021
		CHECKED AS
PER FDEP RAI #1 COMMENTS	09/09/2022	
PER SJRWMD FIELD INSPECTION	08/23/2022	DATE ISSUED 08/11/2022

MBV ENGINEERING, INC.
 MOIRA BOWLES VILLAMIZAR & ASSOCIATES
 CONSULTING ENGINEERING CA #3728
 1835 20TH STREET
 VERO BEACH, FL 32960
 PH. (772) 569-0035
 FX. (772) 778-3617
 MELBOURNE, FL - PH (321) 253-1510
 FT. PIERCE, FL - PH (772) 468-9065

HISTORIC TRANS-FLORIDA RAIL
 TRAIL PHASE 2 EXTENSION
 INDIAN RIVER COUNTY FLORIDA

TYPICAL SECTION
 DATE: 21-0311

SHEET
C5
 21-0311

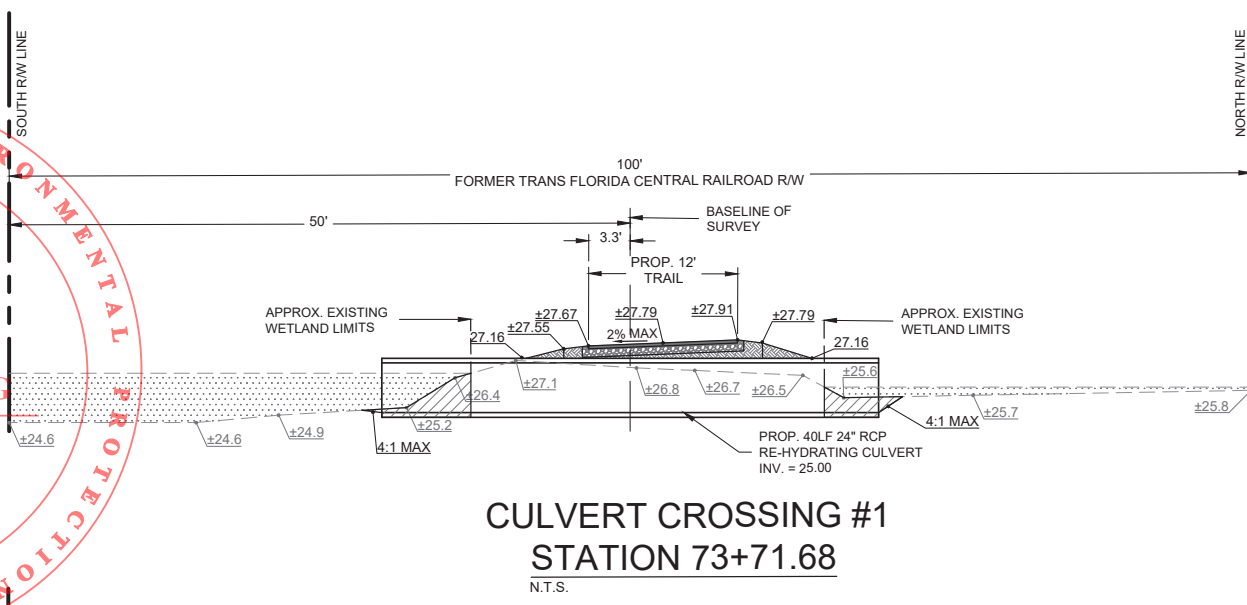
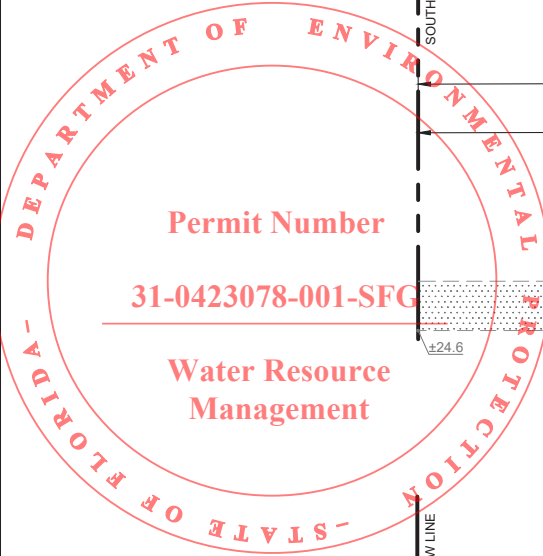

LEGEND

- EXISTING WETLANDS
- PROPOSED FILL
- PROPOSED EXCAVATION

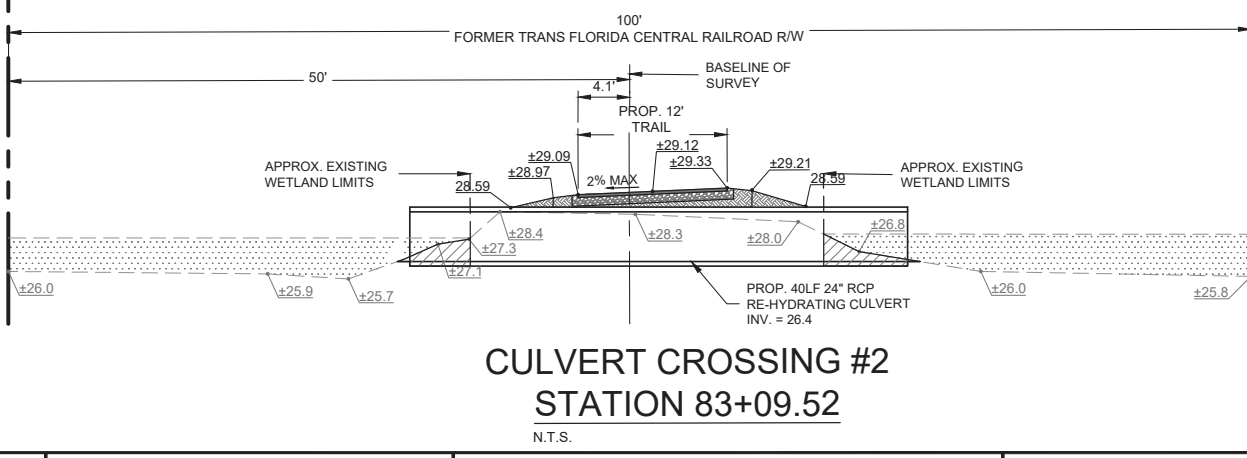

LEGEND

- EXISTING WETLANDS
- PROPOSED FILL
- PROPOSED EXCAVATION

REVISIONS	DATE	JOB NO.
---	---	21-0311
DESIGNED	TH	
DRAWN	SS	
DATE	DEC. 2021	
CHECKED	AS	
PER FDEP RAI #1 COMMENTS	09/09/2022	
PER SJRWMD FIELD INSPECTION	08/23/2022	

MBV ENGINEERING, INC.
 MOYA BOWLES VILLAMIZAR & ASSOCIATES
 CONSULTING ENGINEERING CA #3728

1835 20TH STREET
 VERO BEACH, FL 32960
 PH. (772) 569-0035
 FX. (772) 778-3617

MELBOURNE, FL - PH (321) 253-1510
 FT. PIERCE, FL - PH (772) 468-9055

HISTORIC TRANS-FLORIDA RAIL
 TRAIL PHASE 2 EXTENSION

INDIAN RIVER COUNTY FLORIDA

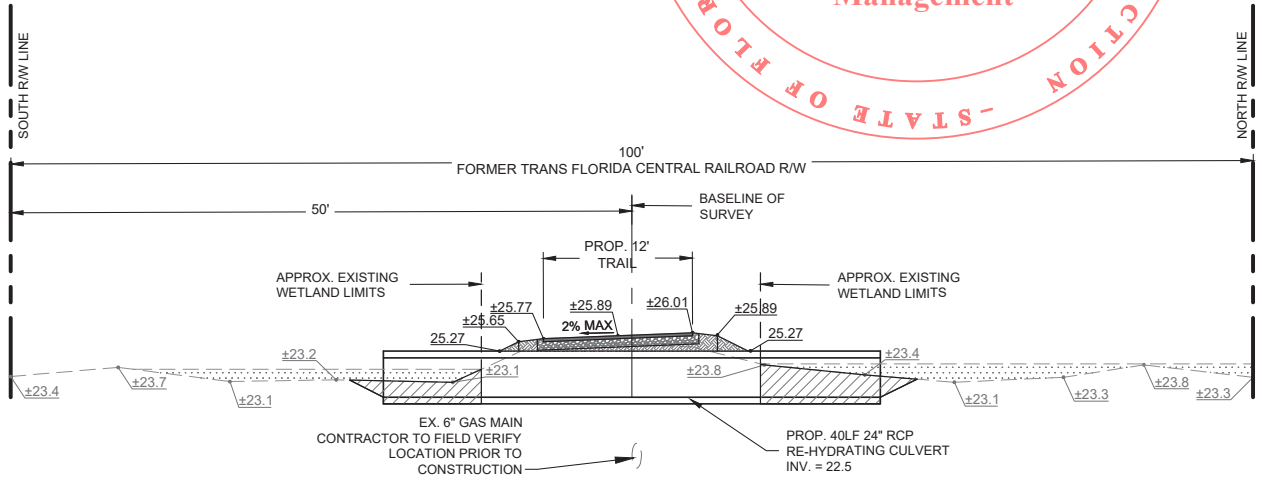

WETLAND RE-HYDRATION CULVERT
 SECTIONS

SHEET
C6
 DATE: 21-0311

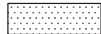

CULVERT CROSSING #3
STATION 141+00
 N.T.S.

LEGEND

	EXISTING WETLANDS
	PROPOSED FILL
	PROPOSED EXCAVATION

REVISIONS	DATE	JOB NO.
		21-0311
DESIGNED		TH
DRAWN		SS
DATE	DEC. 2021	
CHECKED		AS
PER FDEP RAI #1 COMMENTS	09/09/2022	
PER SJRWMD FIELD INSPECTION	08/23/2022	

MBV ENGINEERING, INC.
 MOIJA BOWLES VILLAMIZAR & ASSOCIATES
 CONSULTING ENGINEERING CA #3728

1835 20TH STREET
 VERO BEACH, FL 32960
 PH. (772) 569-0035
 FX. (772) 778-3617

MELBOURNE, FL - PH (321) 253-1510
 FT. PIERCE, FL - PH (772) 468-9065

HISTORIC TRANS-FLORIDA RAIL
 TRAIL PHASE 2 EXTENSION

INDIAN RIVER COUNTY FLORIDA

WETLAND RE-HYDRATION CULVERT
 SECTION AND WETLAND IMPACT SECTION

SHEET
C7

DATE: 21-0311

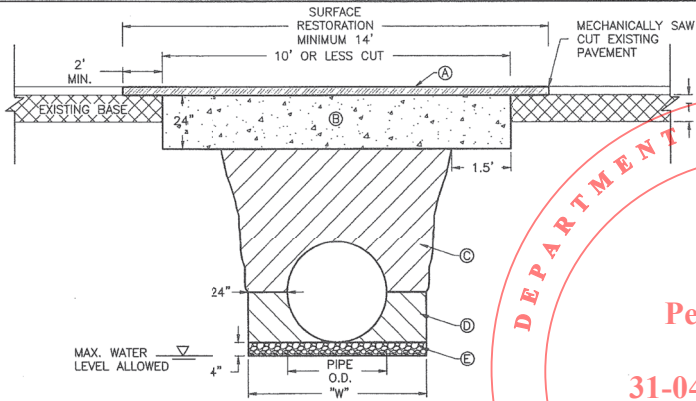

STORMWATER/UTILITY PIPE
INSTALLATION

NOTES:

1. UTILITY CONSTRUCTION WITHIN THE RIGHT-OF-WAY SHALL COMPLY WITH COUNTY CODE CHAPTER 312.
 - 1.1. ALL INSTALLATIONS LESS THAN 12" DIAMETER AND NON GRAVITY UTILITIES SHALL BE BY DIRECTIONAL BURE.
 - 1.2. PARTIAL LANE CUTS REQUIRE A MINIMUM OF SINGLE LANE RESTORATION.
 2. WHERE SOIL CONDITIONS CANNOT BE MAINTAINED AS SHOWN ABOVE, PROVIDE APPROVED METHOD OF CONSTRUCTION FOR APPROVAL BY THE COUNTY ENGINEER OR DESIGNEE PRIOR TO INSTALLATION.
 3. SHORING MAY BE REQUIRED IN ACCORDANCE WITH ALL INDUSTRY STANDARDS.
 4. NEW SURFACING MATERIALS SHALL BE CONSISTENT OR BETTER THAN EXISTING CONDITIONS AND SHALL HAVE BUTT JOINTS (2.5 INCH MINIMUM THICKNESS).
 5. ALL ROADWAY RESTORATION SHALL COMPLY WITH INDIAN RIVER COUNTY PUBLIC WORKS AND FDOT STANDARDS (LATEST EDITION).
 6. MINIMUM TRENCH WIDTH "W" = PIPE O.D. PLUS 2'-0" ON EACH SIDE.
- Ⓐ MINIMUM EXISTING PAVEMENT DEPTH OR PER COUNTY ROADWAY DESIGN CRITERIA DETAIL, WHICHEVER IS GREATER.
- Ⓑ FLOWABLE FILL AS DEFINED AS NON-EXCAVATABLE IN ACCORDANCE WITH FDOT STANDARD SPECIFICATIONS FOR ROAD AND BRIDGE CONSTRUCTION, SECTION 121, WITH STRENGTH OF 125-300 PSI.
- Ⓒ A.A.S.H.T.O. TYPE A-3 MATERIAL IN MAXIMUM 6" LIFTS COMPACTED AT 98% A.A.S.H.T.O. T-180.
- Ⓓ A.A.S.H.T.O. TYPE A-3 MATERIAL IN MAXIMUM 4" LIFTS COMPACTED AT 98% A.A.S.H.T.O. T-180. EXCAVATABLE FLOWABLE FILL IS ALLOWED WITH PRIOR APPROVAL OF PROPOSED MATERIAL STRENGTH BY THE COUNTY ENGINEER OR DESIGNEE.
- Ⓔ ¾" DIAMETER, WASHED BEDDING ROCK OR PEA ROCK WHERE UNSUITABLE BEDDING MATERIAL EXISTS OR IF DEWATERING IS REQUIRED. SUITABLE MATERIAL IS DEFINED AS STABLE GRANULAR MATERIAL FREE OF ROCK FORMATION, OTHER FOREIGN FORMATIONS AND CONSTRUCTED TO UNIFORM GRADE AND LINE.

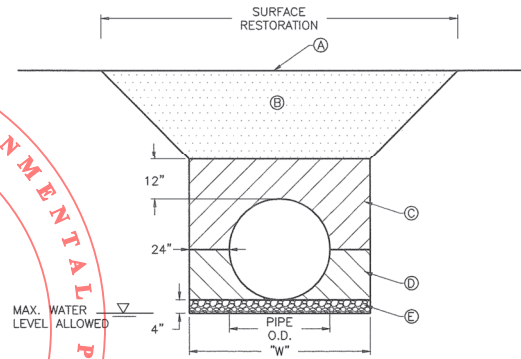

STORMWATER/UTILITY PIPE
INSTALLATION

NOTES:

1. UTILITY CONSTRUCTION WITHIN THE RIGHT-OF-WAY SHALL COMPLY WITH COUNTY CODE CHAPTER 312.
 - 1.1. ALL INSTALLATIONS LESS THAN 12" DIAMETER AND NON GRAVITY UTILITIES SHALL BE BY DIRECTIONAL BURE.
 - 1.2. PARTIAL LANE CUTS REQUIRE A MINIMUM OF SINGLE LANE RESTORATION.
 2. WHERE SOIL CONDITIONS CANNOT BE MAINTAINED AS SHOWN ABOVE, PROVIDE METHOD OF CONSTRUCTION FOR APPROVAL BY COUNTY ENGINEER OR DESIGNEE PRIOR TO INSTALLATION.
 3. SHORING MAY BE REQUIRED IN ACCORDANCE WITH ALL INDUSTRY STANDARDS.
 4. MINIMUM TRENCH WIDTH "W" = PIPE O.D. PLUS 2'-0" ON EACH SIDE.
- Ⓐ MATCH EXISTING GROUND WITH SMOOTH, LEVEL TRANSITION.
- Ⓑ UNPAVED ROADS IN ROW SHALL CONSIST OF 8" LIMEROCK BASE OR COQUINA SHELL IN A MINIMUM OF (2) 4" LIFTS WITH A MINIMUM LBR OF 100 COMPACTED TO 98% MAXIMUM DENSITY PER A.A.S.H.T.O. T-180. WHEN INSTALLATION IS NOT LOCATED IN A TRAVEL LANE, RESTORATION SHALL BE ACCORDING TO Ⓒ BELOW WITH SOD LAID WITHIN THREE DAYS OF FINAL GRADING.
- Ⓒ A.A.S.H.T.O. TYPE A-3 MATERIAL IN MAXIMUM 6" LIFTS COMPACTED AT 98% A.A.S.H.T.O. T-180.
- Ⓓ A.A.S.H.T.O. TYPE A-3 MATERIAL IN MAXIMUM 4" LIFTS COMPACTED AT 98% A.A.S.H.T.O. T-180. EXCAVATABLE FLOWABLE FILL IS ALLOWED WITH PRIOR APPROVAL OF PROPOSED MATERIAL STRENGTH BY COUNTY ENGINEER OR DESIGNEE.
- Ⓔ ¾" DIAMETER, WASHED BEDDING ROCK OR PEA ROCK WHERE UNSUITABLE BEDDING MATERIAL EXISTS OR DEWATERING IS REQUIRED. SUITABLE MATERIAL IS DEFINED AS STABLE GRANULAR MATERIAL FREE OF ROCK FORMATION, OTHER FOREIGN FORMATIONS AND CONSTRUCTED TO UNIFORM GRADE AND LINE.

FLORIDA - DEPARTMENT OF ENVIRONMENTAL PROTECTION - STATE

Permit Number
31-0423078-001-SFG

Water Resource Management

LAND DEVELOPMENT DESIGN STANDARDS AND SPECIFICATIONS		TRENCH (PAVED AREAS) 10' OR LESS CUT
DATE:	11/1/2016	
INDEX:	1B	
James William Ennis, P.E. Florida Reg. No. 7193B Public Works - County Engineer		

LAND DEVELOPMENT DESIGN STANDARDS AND SPECIFICATIONS		TRENCH (UNPAVED AREAS)
DATE:	11/1/2016	
INDEX:	2	
James William Ennis, P.E. Florida Reg. No. 7193B Public Works - County Engineer		

REVISIONS	DATE	JOB NO.
Δ		21-0311
---		DESIGNED TH
---		DRAWN SS
---		DATE DEC. 2021
---		CHECKED AS
Δ	09/09/2022	PER FDEP RAI #1 COMMENTS
Δ	08/23/2022	PER SJRWMD FIELD INSPECTION

MBV ENGINEERING, INC.
 MOVA BOWLES VILLAMIZAR & ASSOCIATES
 CONSULTING ENGINEERING CA #3728

1835 20TH STREET
 VERO BEACH, FL 32960
 PH. (772) 569-0035
 FX. (772) 778-3617

MELBOURNE, FL - PH (321) 253-1510
 FT. PIERCE, FL - PH (772) 468-9055

INDIAN RIVER COUNTY
 HISTORIC TRANS-FLORIDA RAIL
 TRAIL PHASE 2 EXTENSION
 FLORIDA

PIPE INSTALLATION DETAILS

DATE: 21-0311

SHEET
C8

GENERAL NOTES:

- GOVERNING SPECIFICATIONS: FLORIDA DEPARTMENT OF TRANSPORTATION "STANDARD SPECIFICATIONS FOR ROAD AND BRIDGE CONSTRUCTION" DATED JANUARY 2022 AND INDIAN RIVER COUNTY STANDARD SPECIFICATIONS.
- CONSTRUCTION DETAILS SHALL BE IN ACCORDANCE WITH FLORIDA DEPARTMENT OF TRANSPORTATION STANDARD PLANS FY 2021-22.
- ALL STATIONS AND OFFSETS ARE REFERENCED TO BASELINE OF SURVEY.
- ALL DISTURBED R/W SHALL BE SODDED WITHIN SEVEN DAYS OF FINAL GRADING. ALL SOD PLACED ON A SLOPE STEEPER THAN 4:1 SHALL BE PEGGED. COST OF PEGGING SOD SHALL BE INCLUDED IN PERFORMANCE TURF UNIT COST. ALL SOD TO BE NON-INVASIVE.
- THE CONTRACTOR WILL RESTORE ALL AREAS DISTURBED BY THIS CONSTRUCTION TO A CONDITION EQUAL TO, OR BETTER THAN THAT NOW EXISTING.
- ITEMS IN CONFLICT WITH CONSTRUCTION SUCH AS EXISTING SIDEWALKS, DRAINAGE STRUCTURES, PAVEMENT AND BASE AND EXCESS EXCAVATIONS ARE TO BE REMOVED BY CONTRACTOR AND DISPOSED OF IN A LEGAL AND PROPER MANNER AWAY FROM THE JOB SITE AT THE CONTRACTOR'S EXPENSE, UNLESS THE ITEMS ARE SPECIFIED TO BE REUSED ON THE PROJECT.
- EXISTING TREES WITHIN THE PROJECT LIMITS ARE INTENDED TO REMAIN, UNLESS THEY ARE IN DIRECT CONFLICT WITH THE PROPOSED IMPROVEMENTS OR INDICATED TO BE REMOVED. CONTRACTOR SHALL TAKE DUE CARE AS TO PROTECT EXISTING TREES WITHIN THE PROJECT LIMITS THAT ARE NOT IN DIRECT CONFLICT WITH THE IMPROVEMENTS. THE CONTRACTOR SHALL REMOVE ALL EXOTIC VEGETATION LOCATED WITH THE PROJECT LIMITS WITHIN PUBLIC RIGHT OF WAY. COST OF TREE PRESERVATION SHALL BE INCLUDED WITHIN PAY ITEM 104-2 AND EXOTIC VEGETATION REMOVAL SHALL BE INCLUDED WITHIN PAY ITEM 110-1-1.
- STAGING AND MATERIAL STORAGE SHALL NOT BE CONDUCTED ON ANY ABUTTING PRIVATE PROPERTY WITHOUT WRITTEN AGREEMENT APPROVAL FROM THE OWNER. UPON PROJECT COMPLETION, SHOULD CONTRACTOR HAVE STAGED AND/OR STORED MATERIAL ON PRIVATE PROPERTY THE CONTRACTOR SHALL OBTAIN A WRITTEN RELEASE FROM THE PROPERTY OWNER. A COPY OF THE WRITTEN RELEASE SHALL BE PROVIDED TO THE COUNTY.
- NO EXISTING BASE MATERIAL REMOVED IN EXCAVATION SHALL BE REUSED AS PROPOSED BASE MATERIAL.
- CLEARING AND GRUBBING - WITHIN THE LIMITS OF CONSTRUCTION, ALL VEGETATION AND ROOT MATERIAL SHALL BE REMOVED.
- ALL VEGETATION, DEBRIS, A.C., CONCRETE OR OTHER UNSUITABLE MATERIAL SHALL BE DISPOSED OF OFF-SITE BY THE CONTRACTOR IN LEGAL MANNER AT THE CONTRACTOR'S EXPENSE.
- SOD PLACEMENT SHALL BE AS PER F.D.O.T. INDEX #105. SOD TYPE SHALL MATCH EXISTING GRASS AND NOT BE OF ANY TYPE OF INVASIVE SPECIES.
- ANY EXISTING ROADWAY AND/OR UTILITY THAT IS DAMAGED BY THE CONTRACTOR SHALL BE CORRECTED AT THE CONTRACTOR'S EXPENSE.
- EXISTING DRAINAGE STRUCTURES AND PIPES WITHIN THE CONSTRUCTION LIMITS SHALL REMAIN UNLESS OTHERWISE NOTED.
- SURFACE COURSE - TYPE F.C. 9.5 AND STRUCTURAL COURSE-TYPE S.P. 12.5 SHALL CONFORM TO THE REQUIREMENTS OF THE F.D.O.T. SPECIFICATIONS, 2022 EDITION, SECTION 334, THE MINIMUM COMPACTED THICKNESS TO BE AS NOTED.
- EMBANKMENT, SUBGRADE, BASE AND ASPHALT ARE 'IN PLACE' MEASUREMENTS.
- THERE SHALL BE NO EXCAVATIONS LEFT OPEN AFTER END OF SHIFT, UNLESS POSITIVELY SHIELDED.
- ALL CONSTRUCTION EQUIPMENT AND MATERIALS SHALL BE STORED IN AN AREA DESIGNATED BY THE PARKS MANAGEMENT STAFF TO AVOID IMPACTS TO THE ENVIRONMENTALLY SENSITIVE AREAS.
- THE CONTRACTOR SHALL NOTIFY IRC MPO AT (772) 226-1034 & FDEP PARKS MANAGEMENT STAFF, 48 HOURS PRIOR TO BEGINNING CONSTRUCTION.
- GUARANTEE - ALL MATERIAL AND EQUIPMENT TO BE FURNISHED AND/OR INSTALLED BY THE CONTRACTOR UNDER THIS CONTRACT SHALL BE GUARANTEED FOR A PERIOD OF ONE YEAR FROM THE DATE OF FINAL ACCEPTANCE THEREOF, AGAINST DEFECTIVE MATERIALS, DESIGN AND WORKMANSHIP. UPON RECEIPT OF NOTICE FROM THE OWNER OF FAILURE OF ANY PART OF THE GUARANTEED EQUIPMENT OR MATERIALS DURING THE GUARANTY PERIOD, THE AFFECTED PART, PARTS OR MATERIALS SHALL BE REPAIRED OR REPLACED BY THE CONTRACTOR AT NO EXPENSE TO THE OWNER. IN THE EVENT THE CONTRACTOR FAILS TO MAKE THE NECESSARY REPLACEMENT OR REPAIRS WITHIN SEVEN DAYS AFTER NOTIFICATION BY THE OWNER, THE OWNER MAY ACCOMPLISH THE WORK AT THE EXPENSE OF THE CONTRACTOR. (FINAL ACCEPTANCE IS CONSIDERED TO BE FINAL APPROVAL BY THE I.R.C. BOARD OF COUNTY COMMISSIONERS.)
- ALL CHANGES SHALL BE APPROVED IN WRITING BY INDIAN RIVER COUNTY AND THE ENGINEER OF RECORD.

- ATTENTION IS DIRECTED TO THE FACT THAT THESE PLANS MAY HAVE BEEN CHANGED IN SIZE BY REPRODUCTION. THIS MUST BE CONSIDERED WHEN OBTAINING SCALED DATA.
- CONTRACTOR SHALL UTILIZE CONSTRUCTION METHODS AND DEVICES SUCH AS TURBIDITY BARRIERS, SYNTHETIC BALES AND FLOATING SILT BARRIERS WHERE NECESSARY TO COMPLY WITH ALL LOCAL, STATE AND FEDERAL WATER QUALITY STANDARDS.

FDEP SPECIAL CONDITIONS:

- CONTRACTOR SHALL DECONTAMINATE ALL EQUIPMENT BEFORE ENTERING OR LEAVING THE PROJECT AREA, TO ENSURE THAT NO PROPAGATES OR REPRODUCTIVE MATERIAL IS TRANSPORTED BETWEEN TREATMENT SITES OR MANAGED AREAS.
- IT SHALL BE THE RESPONSIBILITY OF THE ST. SEBASTIAN RIVER PRESERVE STATE PARK STAFF TO INSPECT ALL EQUIPMENT PRIOR TO WORK COMMENCING ON THE FIRST DAY AT THE PROJECT SITE. ON ANY OCCASION THAT THE EQUIPMENT LEAVES THE PROJECT SITE, AND ANY TIME DURING THE COURSE OF THE OPERATION, ARRANGEMENTS FOR INSPECTIONS MUST BE MADE IN ADVANCE BY THE CONTRACTOR WITH PARK STAFF.

UNIDENTIFIED AREAS OF CONTAMINATION

- WHEN ENCOUNTERING OR EXPOSING ANY ABNORMAL CONDITION INDICATING THE PRESENCE OF A HAZARDOUS OR TOXIC WASTE, OR CONTAMINANTS, CEASE OPERATIONS IMMEDIATELY IN THE VICINITY AND NOTIFY THE INDIAN RIVER COUNTY LAP ENGINEER. THE PRESENCE OF TANKS OR BARRELS; DISCOLORED EARTH, METAL, WOOD, GROUND WATER, ETC.; VISIBLE FUMES; ABNORMAL ODORS; EXCESSIVELY HOT EARTH; SMOKE; OR OTHER CONDITIONS THAT APPEAR ABNORMAL MAY INDICATE HAZARDOUS OR TOXIC WASTES OR CONTAMINANTS AND MUST BE TREATED WITH EXTREME CAUTION.
- MAKE EVERY EFFORT TO MINIMIZE THE SPREAD OF CONTAMINATION INTO UNCONTAMINATED AREAS. IMMEDIATELY PROVIDE FOR THE HEALTH AND SAFETY OF ALL WORKERS AT THE JOB SITE AND MAKE PROVISIONS NECESSARY FOR THE HEALTH AND SAFETY OF THE PUBLIC THAT MAY BE EXPOSED TO ANY POTENTIALLY HAZARDOUS CONDITIONS. PROVISIONS SHALL MEET ALL APPLICABLE LOCAL, STATE, AND FEDERAL LAWS, RULES, REGULATIONS OR CODES COVERING HAZARDOUS CONDITIONS AND WILL BE IN A MANNER COMMENSURATE WITH THE GRAVITY OF THE CONDITIONS.
- THE INDIAN RIVER COUNTY LAP ENGINEER WILL COORDINATE AND MOBILIZE A QUALIFIED CONTAMINATION ASSESSMENT/REMEDIATION (C.A.R.) CONTRACTOR. QUALIFICATIONS OF SUCH C.A.R. CONTRACTOR SHALL INCLUDE, BUT NOT BE LIMITED TO: EXPERIENCE AND PERSONNEL TO PREPARE CONTAMINATION ASSESSMENT PLANS, CONDUCT CONTAMINATION ASSESSMENTS, PREPARE SITE ASSESSMENT REPORTS, REMEDIATION PLANS, IMPLEMENT REMEDIAL ACTION PLANS, RISK BASED CORRECTIVE ACTIONS, STORAGE TANKS SYSTEM REMOVAL, HIGHWAY SPILL RESPONSE AS WELL AS EXPERIENCE WITH INFRASTRUCTURE/CONSTRUCTION ACTIVITIES WITHIN (POTENTIALLY) CONTAMINATED AREAS SPECIFIC TO TRANSPORTATION SYSTEMS.
- ALL THE WORK PERFORMED BY THE C.A.R. CONTRACTOR SHALL BE PERFORMED IN COMPLIANCE WITH ALL APPLICABLE LOCAL, STATE AND FEDERAL REGULATIONS GOVERNING WORKER SAFETY AND ENVIRONMENTAL REGULATIONS. THIS IS TO INCLUDE OCCUPATIONAL EXPOSURE TO CONTAMINATED SOILS, GROUNDWATER, WASTES AND ATMOSPHERE DURING THE CONSTRUCTION OF ALL FEATURES INCLUDED IN THE CONSTRUCTION PLANS. IN ADDITION, THE C.A.R. CONTRACTOR MUST BE STAFFED WITH FLORIDA LICENSED TECHNICAL PROFESSIONALS (GEOLOGISTS AND ENGINEERS) WHO WILL BE INVOLVED WITH THE PROJECT AND KNOWLEDGEABLE OF THE WORK ACTIVITIES CONDUCTED WITHIN THE IDENTIFIED CONTAMINATED AREAS AND WHO WOULD SIGN AND SEAL PROJECT REPORTS AS REQUIRED FOR SUBMITTAL TO THE APPROPRIATE ENVIRONMENTAL REGULATORY AGENCIES.
- THE INDIAN RIVER COUNTY LAP ENGINEER WILL IMMEDIATELY NOTIFY THE FLORIDA DEPARTMENT OF TRANSPORTATION (FDOT) DISTRICT IV CONTAMINATION IMPACT COORDINATOR (DCIC) AT (854) 777-4286 AFTER ENCOUNTERING THE UNIDENTIFIED AREAS OF CONTAMINATION. PRELIMINARY INVESTIGATION BY THE C.A.R. CONTRACTOR WILL DETERMINE THE COURSE OF ACTION NECESSARY FOR SITE SECURITY AND THE STEPS NECESSARY UNDER APPLICABLE LAWS, RULES, AND REGULATIONS FOR ADDITIONAL ASSESSMENT AND/OR REMEDIATION WORK TO RESOLVE THE CONTAMINATION ISSUE.
- FOLLOWING COMPLETION OF THE PROJECT, THE C.A.R. CONTRACTOR SHALL BE REQUIRED TO PROVIDE COPIES OF ALL REPORTS SUBMITTED TO REGULATORY AGENCIES, WASTE MATERIAL PROFILES, MANIFESTS AND/OR DISPOSAL RECEIPTS FOR THE HANDLING OF ALL CONTAMINATED MEDIA INCLUDING BUT NOT LIMITED TO GROUND WATER, WASTE WATER, SOILS, SOLID WASTES, SLUDGE, HAZARDOUS WASTES, AIR MONITORING RECORDS AND SAMPLE RESULTS FOR ALL MATERIALS TESTED AND ANALYZED TO THE INDIAN RIVER COUNTY LAP ENGINEER AND THE FDOT DCIC.
- THIS PROJECT DOES NOT ANTICIPATE THE USE OF ANY TEMPORARY FILLS. SHOULD THE CONTRACTOR NEED TO UTILIZE TEMPORARY FILL DURING THE CONSTRUCTION PHASE, THESE FILLS SHALL BE REMOVED UPON COMPLETION AND THE AREA RESTORED TO PRE-CONSTRUCTION CONDITIONS PURSUANT TO F.A.C. 62-33.217.

INVASIVE SPECIES MANAGEMENT: DECONTAMINATION GUIDELINES FOR EQUIPMENT AND PPE

PRELIMINARY STATEMENT EXAMPLES:

- THE CONTRACTOR SHALL REQUIRE ALL PERSONNEL TO PRACTICE PROPER SANITATION PROCEDURES FOR ALL EQUIPMENT (INCLUDING PERSONAL PROTECTIVE GEAR) TO AVOID UNNECESSARY SPREADING OF INVASIVE AND EXOTIC PEST PLAN SPECIES WITHIN AND FROM THE TREATMENT SITE.
- CONTRACTORS WORKING ON INVASIVE EXOTIC REMOVAL PROJECTS MUST ADHERE TO THE FOLLOWING PROTOCOL:
 - MANDATORY DECONTAMINATION PROTOCOLS MUST BE FOLLOWED FOR VEHICLES AND EQUIPMENT PRIOR TO ENTERING INDIAN RIVER COUNTY FROM OUTSIDE OF THE COUNTY
 - WHEN MOVING EQUIPMENT FROM SIT TO SITE WITHIN INDIAN RIVER COUNTY, DECONTAMINATION REQUIREMENTS WILL BE AT THE DISCRETION OF THE PROJECT MANAGER AND WILL BE DEPENDANT UPON THE EXOTIC SPECIES THAT WERE TREATED AT THE PREVIOUS SITE, AND ON THE NATURE OF THE TREATMENT SITES.
 - IF DECONTAMINATION IS REQUIRED BY THE PROJECT MANAGER THEN THE CONTRACTOR MUST UTILIZE A DESIGNATED DECONTAMINATION SITE WITHIN INDIAN RIVER COUNTY. THE PROJECT MANAGER SHALL SUPPLY THE CONTRACTOR WITH A LIST OF DESIGNATED DECONTAMINATION SITES (THESE MAY INCLUDE COUNTY TRANSFER STATIONS AND DOT STORAGE SITES).
- PRIOR TO THE COMMENCEMENT OF AN INVASIVE PLAN REMOVAL PROJECT, THE SITE MANAGER SHALL ADDRESS THE NECESSITY FOR A DECONTAMINATION PLAN. IF THE PROJECT MANAGER REQUIRES A PLAN, THEN THE CONTRACTOR SHALL SUBMIT A BRIEF DECONTAMINATION PLAN IN WRITING, TO THE PROJECT MANAGER FOR APPROVAL. THE DECONTAMINATION PLAN SHALL IDENTIFY SPECIFIC DECONTAMINATION PROCEDURES AND DECONTAMINATION LOCATIONS. DECONTAMINATION PROTOCOLS MAY VARY DEPENDING UPON THE NATURE OF THE TREATMENT SITE, TYPE OF TREATMENT CONDUCTED AT THE SITE, AND EXOTIC SPECIES THAT ARE SCHEDULED FOR TREATMENT.
 - IT WILL BE THE RESPONSIBILITY OF THE SITE MANAGER TO INSPECT ALL EQUIPMENT PRIOR TO WORK COMMENCING ON THE FIRST DAY AT THE PROJECT SITE, ON ANY OCCASION THAT THE EQUIPMENT LEAVES THE PROJECT SITE, AND ANY TIME DURING THE COURSE OF THE CONTROL OPERATION.
 - FAILURE TO COMPLY WITH THE DECONTAMINATION PROTOCOLS CONSTITUTES A REASON FOR CONTRACT CANCELLATION AND DISMISSAL OF THE CONTRACTOR.

PROTOCOL EXAMPLES:

- ALL EQUIPMENT INCLUDING BUT NOT LIMITED TO VEHICLES, TRAILER, ATV'S, AND CHIPPERS MUST BE CLEANED WITH A PRESSURE WASHER (AT A FACILITY APPROVED BY THE MANAGING AGENCY'S PROJECT MANAGER). DECONTAMINATION PROTOCOLS INCLUDE SPRAYING DOWN ALL EQUIPMENT SURFACES INCLUDING THE UNDERCARRIAGE AND TIRES TO INSURE MUD, VEGETATIVE DEBRIS AND OTHER DEBRIS IN NOT TRANSPORTED FROM THE PREVIOUS TREATMENT SITE. SPECIAL ATTENTION WILL BE PAID TO EQUIPMENT THAT HAS WORKED AT SITE WHERE **LYGODIUM**, **COGAN GRASS** AND OTHER EXOTICS SPECIFIC TO THE MAINLAND WERE TREATED TO PREVENT THE SPREAD OF THESE INTO MONROE COUNTY. EQUIPMENT SUCH AS CHAIN SAWS, LOPPERS, ETC. USED FOR CUT STUMP TREATMENT MUST BE WIPED DOWN AND CLEANED SO THAT THEY ARE FREE OF DEBRIS.
- ALL EQUIPMENT INCLUDING BUT NOT LIMITED TO VEHICLES, TRAILER, ATV'S, AND CHIPPERS MUST BE CLEANED WITH A PRESSURE WASHER TO REDUCE THE SPREAD OF EXOTIC VEGETATION PRIOR TO INITIATING WORK ACTIVITIES ON PUBLIC LANDS. DECONTAMINATION PROTOCOLS INCLUDE SPRAYING DOWN ALL EQUIPMENT SURFACES INCLUDING THE UNDERCARRIAGE AND TIRES TO INSURE MUD, VEGETATIVE DEBRIS AND OTHER DEBRIS IN NOT TRANSPORTED FROM THE PREVIOUS TREATMENT SITE. ALL HAND-HELD EQUIPMENT SUCH AS CHAIN SAWS, LOPPERS, ETC. TO BE USED FOR TREATMENT ACTIVITIES MUST BE WIPED DOWN AND CLEANED SO THAT THEY ARE FREE OF DEBRIS.
- IN AREAS OF KNOWN **LYGODIUM** POPULATIONS, CONCERTED EFFORT WILL BE MADE TO REMOVE SPORES FROM CLOTHING AND BOOTS BY USE OF COMPRESSED AIR ON GARMENTS AND CLEANING BOOT LUGS PRIOR TO LEAVING THE TREATMENT SITE. QUARANTINE EQUIPMENT AT A 'STAGING AREA' AND SPRAY EQUIPMENT THOROUGHLY, INCLUDING THE UNDERCARRIAGE AND TIRES.

US FISH AND WILDLIFE SERVICE SPECIAL CONSTRUCTION NOTES:

- ALL CONSTRUCTION AND PAVING ACTIVITIES WILL OCCUR OUTSIDE OF THE FLORIDA SCRUB-JAY NESTING SEASON FROM JULY 15TH TO FEBRUARY 15TH.
- STORAGE OF MATERIALS AND EQUIPMENT ASSOCIATED WITH THE PROJECT WILL NOT OCCUR IN NEAR SUITABLE HABITAT FOR THE FLORIDA SCRUB-JAY AND WILL BE LIMITED TO DISTURBED AREAS TO HAVE THE GREATEST EXTENT PRACTICABLE.

REVISIONS	DATE	JOB NO.	21-0311
---	---	DESIGNED	TH
---	---	DRAWN	SS
---	---	DATE	DEC. 2021
---	---	CHECKED	AS
PER FDEP #1 COMMENTS	09/09/2022		
PER SJRWMD FIELD INSPECTION	08/23/2022	DATE ISSUED	08/11/2022



1835 20TH STREET
 VERO BEACH, FL 32960
 PH. (772) 569-0035
 FX. (772) 778-3617

MOVA BOWLES VILLAMIZAR & ASSOCIATES
 CONSULTING ENGINEERING CA #93728
 MELBOURNE, FL - PH (321) 253-1510
 FT. PIERCE, FL - PH (772) 488-8065

**HISTORIC TRANS-FLORIDA RAIL
 TRAIL PHASE 2 EXTENSION**

INDIAN RIVER COUNTY

FLORIDA

**GENERAL NOTES AND
 SPECIAL CONDITIONS**

SHEET

C9

DATE: 21-0311

Please keep me
wild & free

If you love me, you won't feed me

Feeding scrub-jays disrupts their natural feeding, breeding & sentinel behavior which can harm them

What's the Harm?

- Feeding scrub-jays can cause earlier breeding which can harm the young & future generations
- Feeding scrub-jays makes them more vulnerable to humans and predators
- Feeding scrub-jays provides them with unnatural foods that are unhealthy



Florida scrub-jay



The Florida scrub-jay is a federally threatened species. Feeding the Florida scrub-jay is unlawful under the Federal Endangered Species Act of 1973 and State FAC Rule 68A-27.003. Violations of these laws are punishable by up to 6 months imprisonment and \$25,000 in fines or 60 days imprisonment and \$500 in fines, respectively.

SCRUB JAY SIGN GRAPHIC
N.T.S.

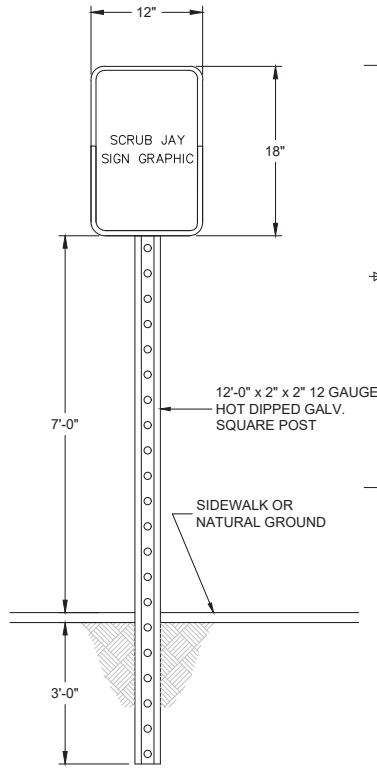

GENERAL NOTES

- SIGN GRAPHIC AND PANEL TO BE DEVELOPED BY IRC AND INSTALLED BY CONTRACTOR.
- THE SIGN SHALL BE PLACED A MINIMUM OF 3' FROM THE EDGE OF THE TRAIL SURFACE OR WHERE DESIGNATED BY PARK STAFF.

SCRUB JAY SIGN DETAIL
N.T.S.

MaxiForce™ Collapsible Bollard
Standard Body, Wrench Operated, Standard Style 1 Head, Simple Base

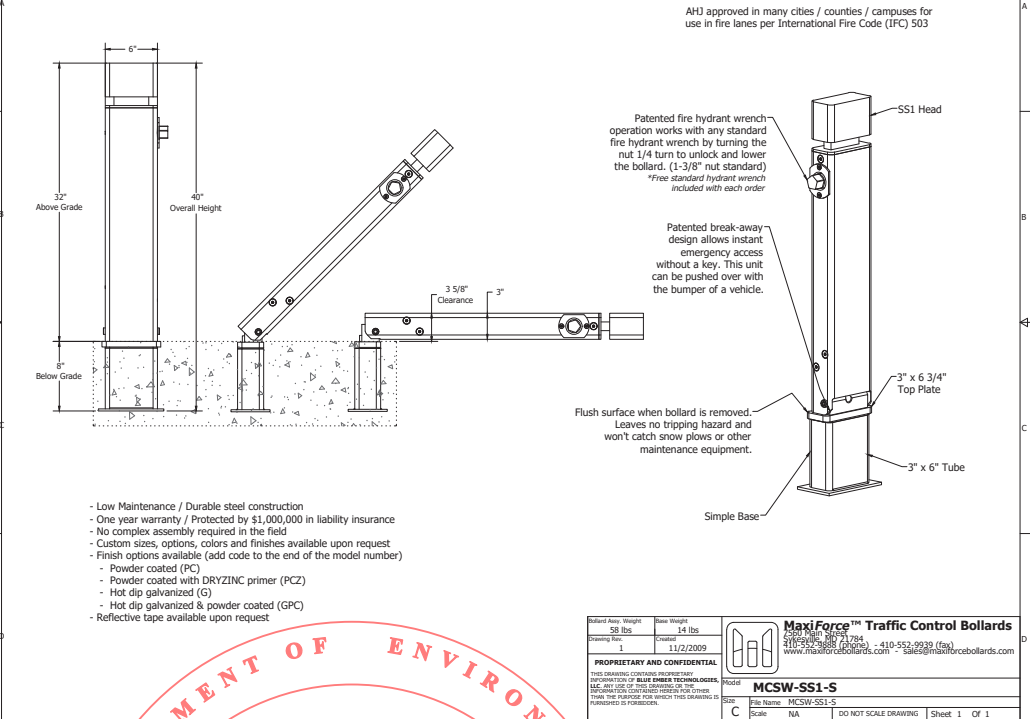

- Low Maintenance / Durable steel construction
- One year warranty / Protected by \$1,000,000 in liability insurance
- No complex assembly required in the field
- Custom sizes, options, colors and finishes available upon request
- Finish options available (add code to the end of the model number)
 - Powder coated (PC)
 - Powder coated with DRYZINC primer (PCZ)
 - Hot dip galvanized (G)
 - Hot dip galvanized & powder coated (GPC)
 - Reflective tape available upon request

Standard Body Weight	14 lbs	MaxiForce™ Traffic Control Bollards 410-552-9939 (toll free) 410-552-9939 (local) www.maxiforcebollards.com • sales@maxiforcebollards.com
Shipping Box	11/2/2009	
Model	MCSW-SS1-S	THIS DRAWING CONTAINS PROPRIETARY INFORMATION OF BLUE BEAR ENGINEERING, LLC. ANY USE OF THIS DRAWING OR THE INFORMATION HEREON WITHOUT THE WRITTEN PERMISSION OF BLUE BEAR ENGINEERING, LLC IS PROHIBITED.
Scale	NA	



COLLAPSIBLE BOLLARD DETAIL

N.T.S.

REVISIONS	DATE	JOB NO.	21-0311
DESIGNED	TH		
DRAWN	SS		
DATE	DEC. 2021		
CHECKED	AS		
PER FDEP RAI #1 COMMENTS	09/09/2022		
PER SJRWMD FIELD INSPECTION	08/23/2022		

MBV ENGINEERING, INC.
MOYA BOWLES VILLAMIZAR & ASSOCIATES
CONSULTING ENGINEERING CA #3728

1835 20TH STREET
VERO BEACH, FL 32960
PH. (772) 569-0035
FX. (772) 778-3617
MELBOURNE, FL - PH (321) 253-1510
FT. PIERCE, FL - PH (772) 468-9065

INDIAN RIVER COUNTY

HISTORIC TRANS-FLORIDA RAIL
TRAIL PHASE 2 EXTENSION

FLORIDA

SITE SIGNAGE AND DETAILS

DATE: 21-0311

SHEET

C10



BEGIN PROJECT 446073-1-59-01
TRANS-FLORIDA RAILWAY TRAIL
STA. 68+00.00



TRAIL PLAN

SCALE: 1" = 60'



GRAPHIC SCALE
0 60
(IN FEET)
1 inch = 60 ft.

LEGEND

-  PROPOSED PAVED TRAIL
-  EXISTING VACATED 100' R/W LINE
-  PROPOSED 60' TRAIL EASEMENT

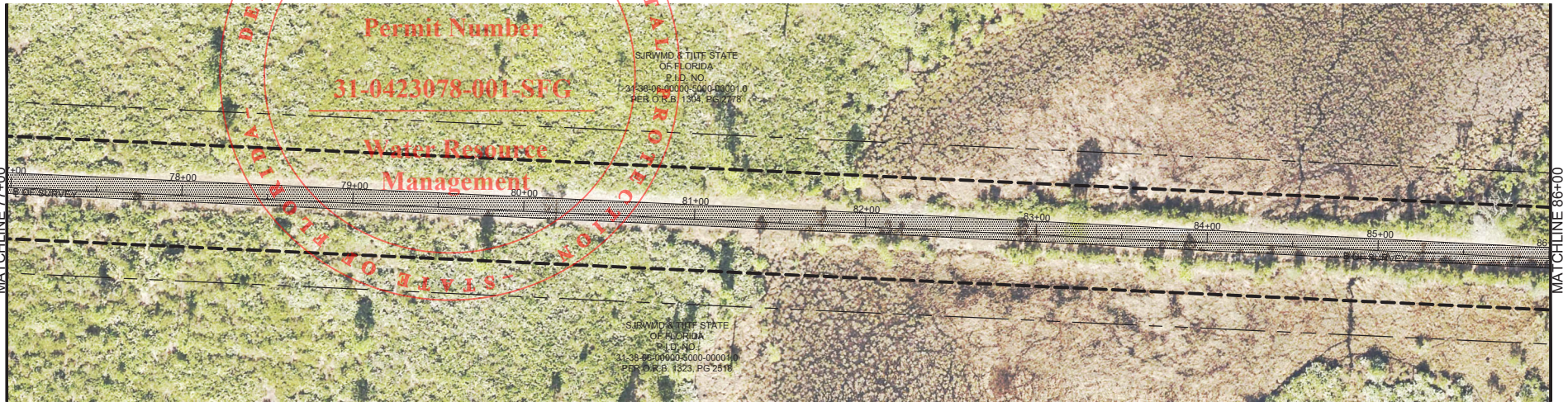

REVISIONS	DATE	JOB NO.
		21-0311
		DESIGNED TH
		DRAWN SS
		DATE DEC. 2021
		CHECKED AS
		DATE ISSUED 08/11/2022

PER FDEP RAI #1 COMMENTS	09/09/2022
PER SURVMD FIELD INSPECTION	08/23/2022

MBV
ENGINEERING, INC.
MOYA BOWLES VILLAMIZAR & ASSOCIATES
CONSULTING ENGINEERING CA #3728

1835 20TH STREET
VERO BEACH, FL 32960
PH. (772) 569-0035
FX. (772) 778-3617
MELBOURNE, FL - PH (321) 253-1510
FT. PIERCE, FL - PH (772) 468-9055

HISTORIC TRANS-FLORIDA RAIL
TRAIL PHASE 2 EXTENSION
INDIAN RIVER COUNTY
FLORIDA

SITE PLAN WITH AERIAL OVERLAY

SHEET
C11
DATE: 21-0311



DEPARTMENT OF ENVIRONMENTAL PROTECTION
STATE OF FLORIDA
 Permit Number
31-0423878-001-SFG
 Water Resource
Management TRAIL PLAN

SJRWMD & TITF STATE OF FLORIDA
 P.I.D. NO. 31-85-06-00000-5000-00001.0
 PER O.R.B. 1304, PG 2778

SJRWMD & TITF STATE OF FLORIDA
 P.I.D. NO. 31-38-06-00000-5000-00001.0
 PER O.R.B. 1323, PG 2518

SCALE: 1" = 60'

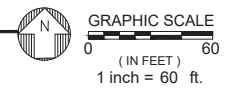

LEGEND

- PROPOSED PAVED TRAIL
- EXISTING VACATED 100' RW LINE
- PROPOSED 60' TRAIL EASEMENT

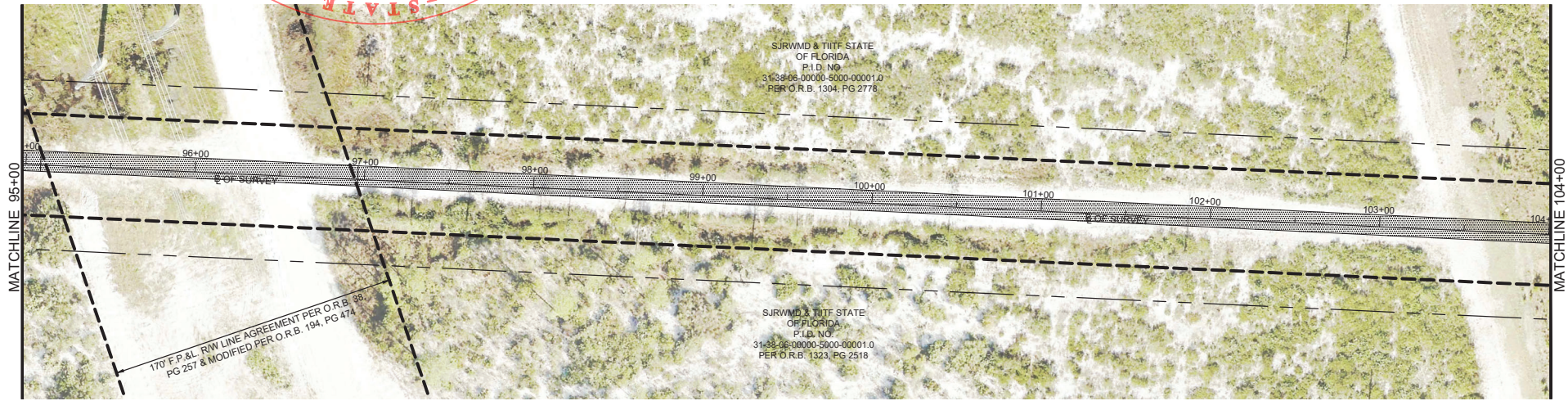

SJRWMD & TITF STATE OF FLORIDA
 P.I.D. NO. 31-38-06-00000-5000-00001.0
 PER O.R.B. 1304, PG 2778

SJRWMD & TITF STATE OF FLORIDA
 P.I.D. NO. 31-38-06-00000-5000-00001.0
 PER O.R.B. 1323, PG 2518

170' F.P.&L. RW LINE AGREEMENT PER O.R.B. 88,
 PG 257 & MODIFIED PER O.R.B. 194, PG 474

REVISIONS	DATE	JOB NO.
		21-0311
		DESIGNED TH
		DRAWN SS
		DATE DEC. 2021
		CHECKED AS
PER FDEP RAI #1 COMMENTS	09/09/2022	
PER SJRWMD FIELD INSPECTION	08/23/2022	

MBV ENGINEERING, INC.
 1835 20TH STREET
 VERO BEACH, FL 32960
 PH. (772) 569-0035
 FX. (772) 778-3617
 MELBOURNE, FL - PH (321) 253-1510
 FT. PIERCE, FL - PH (772) 468-9055

HISTORIC TRANS-FLORIDA RAIL TRAIL PHASE 2 EXTENSION
 INDIAN RIVER COUNTY FLORIDA

SITE PLAN WITH AERIAL OVERLAY
 DATE: 21-0311

SHEET
C12

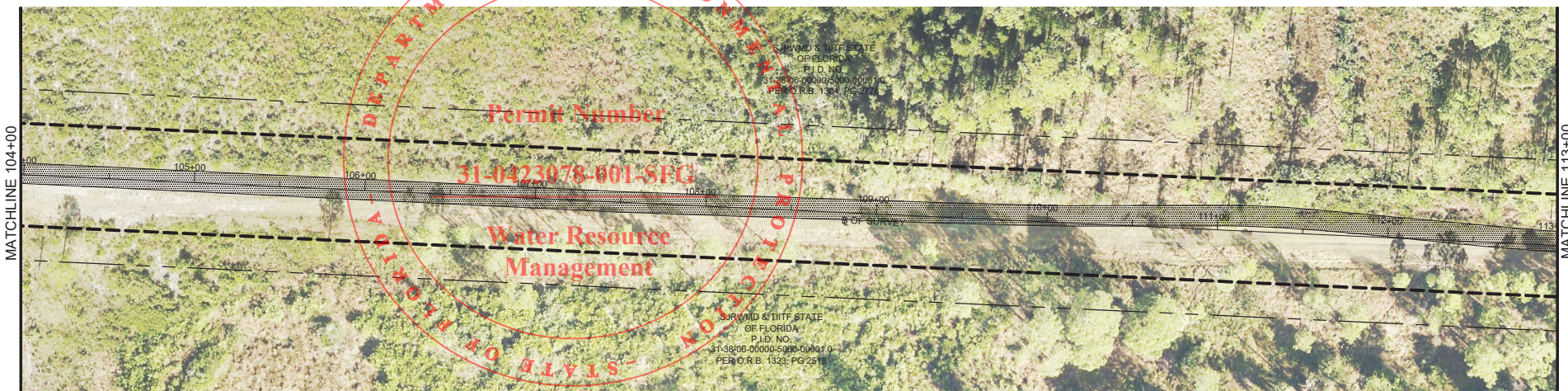
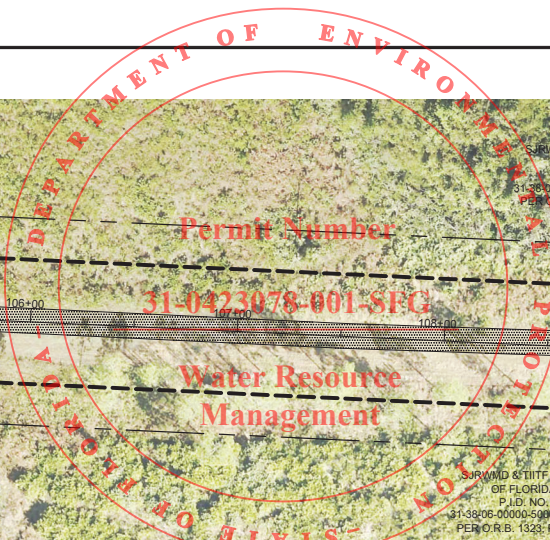

TRAIL PLAN

SCALE: 1" = 60'

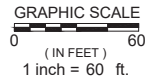

LEGEND

- PROPOSED PAVED TRAIL
- EXISTING VACATED 100' R/W LINE
- PROPOSED 60' TRAIL EASEMENT



REVISIONS	DATE	JOB NO.	21-0311
DESIGNED	TH		
DRAWN	SS		
DATE	DEC. 2021		
CHECKED	AS		
PER FDEP RAI #1 COMMENTS	09/09/2022		
PER SJRWMD FIELD INSPECTION	08/23/2022		

MBV ENGINEERING, INC.
 MOYA BOWLES VILLAMIZAR & ASSOCIATES
 CONSULTING ENGINEERING CA #3728

1835 20TH STREET
 VERO BEACH, FL 32960
 PH. (772) 569-0035
 FX. (772) 778-3617

MELBOURNE, FL - PH (321) 253-1510
 FT. PIERCE, FL - PH (772) 468-9055

HISTORIC TRANS-FLORIDA RAIL
 TRAIL PHASE 2 EXTENSION

INDIAN RIVER COUNTY FLORIDA

SITE PLAN WITH AERIAL OVERLAY

SHEET
C13
 DATE: 21-0311

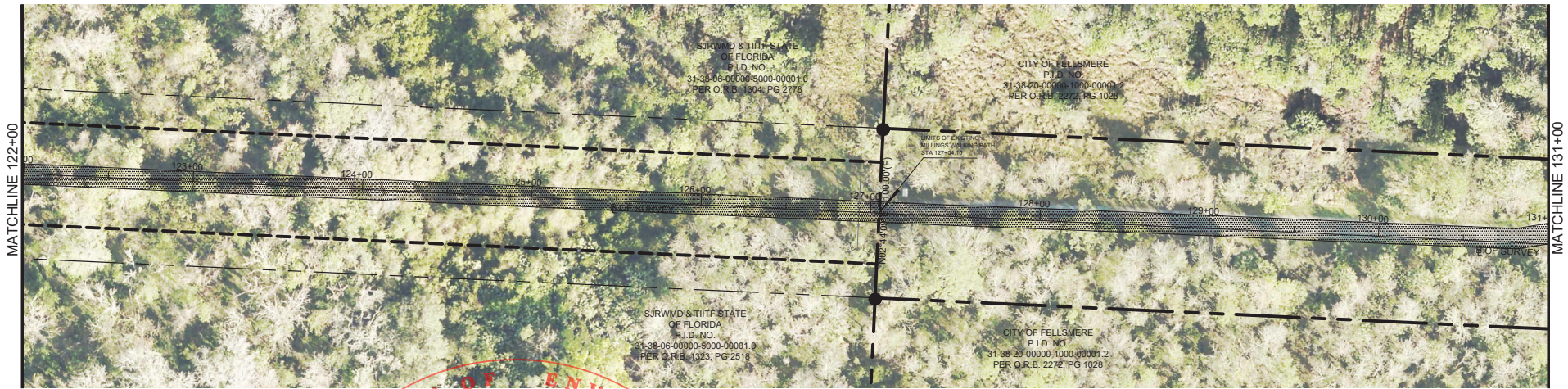

TRAIL PLAN

SCALE: 1" = 60'



GRAPHIC SCALE
0 60
(IN FEET)
1 inch = 60 ft.

LEGEND

- PROPOSED PAVED TRAIL
- EXISTING VACATED 100' R/W LINE
- EXISTING CITY OF FELLSMERE 100' TRAIL EASEMENT
- PROPOSED 60' TRAIL EASEMENT

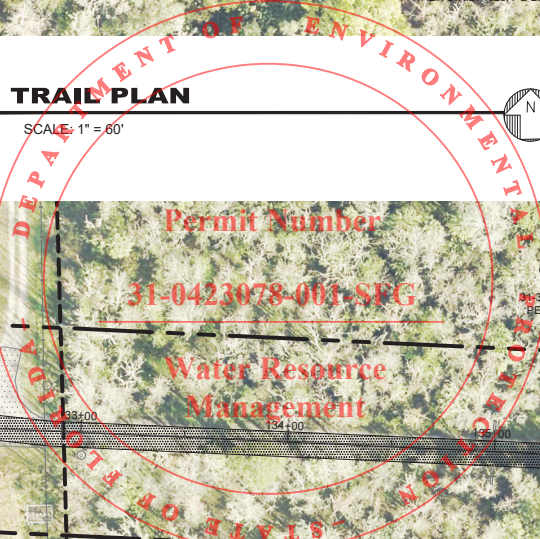
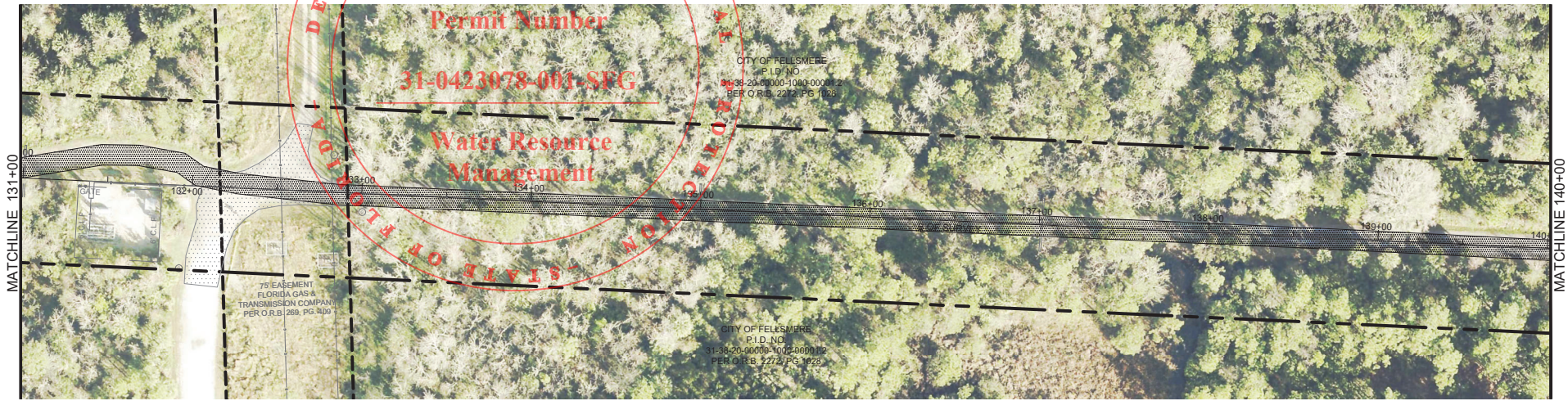

REVISIONS	DATE

JOB NO.	21-0311
DESIGNED	TH
DRAWN	SS
DATE	DEC. 2021
CHECKED	AS
DATE ISSUED	08/11/2022
PER FDEP RAI #1 COMMENTS	09/09/2022
PER SJRWMD FIELD INSPECTION	08/23/2022

MBV ENGINEERING, INC.
MOYA BOWLES VILLAMIZAR & ASSOCIATES
CONSULTING ENGINEERING CA #3728

1835 20TH STREET
VERO BEACH, FL 32960
PH. (772) 569-0035
FX. (772) 778-3617

MELBOURNE, FL - PH (321) 253-1510
FT. PIERCE, FL - PH (772) 468-9065

HISTORIC TRANS-FLORIDA RAIL
TRAIL PHASE 2 EXTENSION

INDIAN RIVER COUNTY FLORIDA

SITE PLAN WITH AERIAL OVERLAY

DATE: _____

SHEET
C14
21-0311



MATCHLINE 140+00

MATCHLINE 148+00

CITY OF FELLSMERE
P.I.D. NO.
338-20-0000-1000-0001.2
PER O.R.B. 2272, PG. 0028

CITY OF FELLSMERE
P.I.D. NO.
338-20-0000-1000-0001.2
PER O.R.B. 2272, PG. 0028

END PROJECT 446073-1-58-01
TRANS-FLORIDA RAILWAY TRAIL
STA. 141+15.04

TRAIL PLAN

SCALE: 1" = 60'



GRAPHIC SCALE
0 60
(IN FEET)
1 inch = 60 ft.

LEGEND



PROPOSED PAVED TRAIL



EXISTING CITY OF FELLSMERE 100' TRAIL EASEMENT

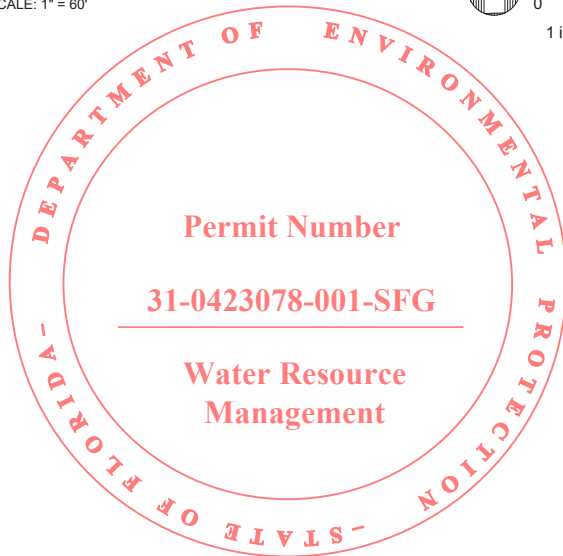

REVISIONS	DATE

JOB NO.	DATE
21-0311	
DESIGNED	TH
DRAWN	SS
DATE	DEC. 2021
CHECKED	AS
DATE ISSUED	08/11/2022

MBV ENGINEERING, INC.
MOJA BOWLES VILLAMIZAR & ASSOCIATES
CONSULTING ENGINEERING CA #3728

1835 20TH STREET
VERO BEACH, FL 32960
PH. (772) 569-0035
FX. (772) 778-3617

MELBOURNE, FL - PH (321) 253-1510
FT. PIERCE, FL - PH (772) 468-9065

HISTORIC TRANS-FLORIDA RAIL
TRAIL PHASE 2 EXTENSION

INDIAN RIVER COUNTY FLORIDA

SITE PLAN WITH AERIAL OVERLAY

DATE: 21-0311

SHEET
C15

NOTES:

1. SILT FENCE SHALL BE PLACED ON SLOPE CONTOURS TO MAXIMIZE PONDING EFFICIENCY.
2. INSPECT AND REPAIR FENCE AFTER EACH STORM EVENT AND REMOVE SEDIMENT WHEN NECESSARY. 9" MAXIMUM RECOMMENDED STORAGE HEIGHT.
3. REMOVED SEDIMENT SHALL BE DEPOSITED TO AN AREA THAT WILL NOT CONTRIBUTE SEDIMENT OFF-SITE AND CAN BE PERMANENTLY STABILIZED.

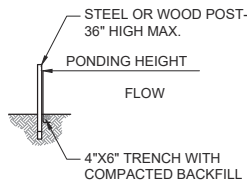
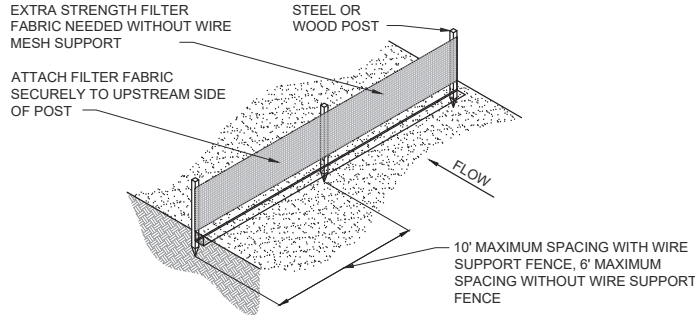

TRENCH DETAIL

TYPE IV SILT FENCE
N.T.S.

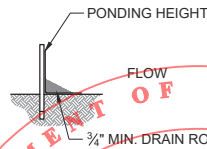

INSTALLATION WITHOUT TRENCHING



EROSION AND SEDIMENTATION CONTROL NOTES

CONSTRUCTION ACTIVITIES CAN RESULT IN THE GENERATION OF SIGNIFICANT AMOUNTS OF POLLUTANTS WHICH MAY REACH SURFACE OR GROUND WATERS. ONE OF THE PRIMARY POLLUTANTS OF SURFACE WATERS IS SEDIMENT DUE TO EROSION. EXCESSIVE QUANTITIES OF SEDIMENT WHICH REACH WATER BODIES OF FLOOD PLAINS HAVE BEEN SHOWN TO ADVERSELY AFFECT THEIR PHYSICAL, BIOLOGICAL AND CHEMICAL PROPERTIES. TRANSPORTED SEDIMENT CAN OBSTRUCT STREAM CHANNELS, REDUCE HYDRAULIC CAPACITY OF WATER BODIES OF FLOOD PLAINS, REDUCE THE DESIGN CAPACITY OF CULVERTS AND OTHER WORKS, AND ELIMINATE BENTHIC INVERTEBRATES AND FISH SPAWNING SUBSTRATES BY SILTATION. EXCESSIVE SUSPENDED SEDIMENTS REDUCE LIGHT PENETRATION AND THEREFORE, REDUCE PRIMARY PRODUCTIVITY.

MINIMUM STANDARDS

1. SEDIMENT BASIN AND TRAPS, PERIMETER DIKES, SEDIMENT BARRIERS AND OTHER MEASURES INTENDED TO TRAP SEDIMENT SHALL BE CONSTRUCTED AS A FIRST STEP IN ANY LAND-DISTURBING ACTIVITY AND SHALL BE MADE FUNCTIONAL BEFORE UNSLOPE LAND DISTURBANCE TAKES PLACE.
2. ALL SEDIMENT CONTROL MEASURES ARE TO BE ADJUSTED TO MEET FIELD CONDITIONS AT THE TIME OF CONSTRUCTION AND BE CONSTRUCTED PRIOR TO ANY GRADING OR DISTURBANCE OF EXISTING SURFACE MATERIAL ON BALANCE OF SITE. PERIMETER SEDIMENT BARRIERS SHALL BE CONSTRUCTED TO PREVENT SEDIMENT OR TRASH FROM FLOWING OR FLOATING ON TO ADJACENT PROPERTIES.
3. PERMANENT OR TEMPORARY SOIL STABILIZATION SHALL BE APPLIED TO DENUDED AREAS WITHIN SEVEN DAYS AFTER FINAL GRADE IS REACHED ON ANY PORTION OF THE SITE. TEMPORARY SOIL STABILIZATION SHALL BE APPLIED WITHIN SEVEN DAYS TO DENUDED AREAS THAT MAY NOT BE AT FINAL GRADE BUT WILL REMAIN UNDISTURBED FOR LONGER THAN 30 DAYS. PERMANENT STABILIZATION SHALL BE APPLIED TO AREAS THAT ARE TO BE LEFT UNDISTURBED FOR MORE THAN ONE YEAR.
4. DURING CONSTRUCTION OF THE PROJECT, SOIL STOCKPILES SHALL BE STABILIZED OR PROTECTED WITH SEDIMENT TRAPPING MEASURES. THE APPLICANT IS RESPONSIBLE FOR THE TEMPORARY PROTECTION AND PERMANENT STABILIZATION OF ALL SOIL STOCKPILES ON SITE AS WELL AS SOIL INTENTIONALLY TRANSPORTED FROM THE PROJECT SITE.
5. A PERMANENT VEGETATIVE COVER SHALL BE ESTABLISHED ON DENUDED AREAS NOT OTHERWISE PERMANENTLY STABILIZED. PERMANENT VEGETATION SHALL NOT BE CONSIDERED ESTABLISHED UNTIL A GROUND COVER IS ACHIEVED THAT, IN THE OPINION OF THE REVIEWER, IS UNIFORM, MATURE ENOUGH TO SURVIVE AND WILL INHIBIT EROSION.
6. STABILIZATION MEASURES SHALL BE APPLIED TO EARTHEN STRUCTURES SUCH AS DAMS, DIKES AND DIVERSIONS IMMEDIATELY AFTER INSTALLATION.
7. SURFACE RUNOFF FROM DISTURBED AREAS THAT IS COMPRISED OF FLOW FROM DRAINAGE AREAS GREATER THAN OR EQUAL TO THREE ACRES SHALL BE CONTROLLED BY A SEDIMENT BASIN. THE SEDIMENT BASIN SHALL BE DESIGNED AND CONSTRUCTED TO ACCOMMODATE THE ANTICIPATED SEDIMENT LOADING FROM THE LAND-DISTURBING ACTIVITY. THE OUTFALL DEVICE OR SYSTEM DESIGN SHALL TAKE INTO ACCOUNT THE TOTAL DRAINAGE AREA FLOWING THROUGH THE DISTURBED AREA TO BE SERVED BY THE BASIN.
8. AFTER ANY SIGNIFICANT RAINFALL, SEDIMENT CONTROL STRUCTURES WILL BE INSPECTED FOR INTEGRITY. ANY DAMAGED DEVICES SHALL BE CORRECTED IMMEDIATELY.
9. CONCENTRATED RUNOFF SHALL NOT FLOW DOWN CUT OR FILL SLOPES UNLESS CONTAINED WITHIN AN ADEQUATE TEMPORARY OR PERMANENT CHANNEL, FLUME OR SLOPE DRAIN STRUCTURE.
10. WHENEVER WATER SEEPS FROM A SLOPE FACE, ADEQUATE DRAINAGE OR OTHER PROTECTION SHALL BE PROVIDED.
11. SEDIMENT WILL BE PREVENTED FROM ENTERING ANY STORM DRAIN SYSTEM, DITCH OR CHANNEL. ALL STORM SEWER INLETS THAT ARE MADE OPERABLE DURING CONSTRUCTION SHALL BE PROTECTED SO THAT SEDIMENT-LADEN WATER CANNOT ENTER THE CONVEYANCE SYSTEM WITHOUT FIRST BEING FILTERED OR OTHERWISE TREATED TO REMOVE SEDIMENT.
12. BEFORE TEMPORARY OR NEWLY CONSTRUCTED STORMWATER CONVEYANCE CHANNELS ARE MADE OPERATIONAL, ADEQUATE OUTLET PROTECTION AND ANY REQUIRED TEMPORARY OR PERMANENT CHANNEL LINING SHALL BE INSTALLED IN BOTH THE CONVEYANCE CHANNEL AND RECEIVING CHANNEL.
13. WHEN WORK IN A LIVE WATERCOURSE IS PERFORMED, PRECAUTIONS SHALL BE TAKEN TO MINIMIZE ENCROACHMENT, CONTROL SEDIMENT TRANSPORT AND STABILIZE THE WORK AREA TO THE GREATEST EXTENT POSSIBLE DURING CONSTRUCTION. NONERODIBLE MATERIAL SHALL BE USED FOR THE CONSTRUCTION OF CAUSEWAYS AND COFFERDAMS. EARTHEN FILL MAY BE USED FOR THESE STRUCTURES IF ARMORED BY NONERODIBLE COVER MATERIALS.
14. WHEN A LIVE WATERCOURSE MUST BE CROSSED BY CONSTRUCTION VEHICLES, A TEMPORARY STREAM CROSSING CONSTRUCTED OF NONERODIBLE MATERIAL SHALL BE PROVIDED.
15. THE BED AND BANKS OF A WATERCOURSE SHALL BE STABILIZED IMMEDIATELY AFTER WORK IN THE WATERCOURSE IS COMPLETED.
16. PERIODIC INSPECTION AND MAINTENANCE OF ALL SEDIMENT CONTROL STRUCTURES MUST BE PROVIDED TO ENSURE INTENDED PURPOSE IS ACCOMPLISHED. THE DEVELOPER, OWNER AND/OR CONTRACTOR SHALL BE CONTINUALLY RESPONSIBLE FOR ALL SEDIMENT LEAVING THE PROPERTY. SEDIMENT CONTROL MEASURES SHALL BE IN WORKING CONDITION AT THE END OF EACH WORKING DAY.
17. WHERE CONSTRUCTION VEHICLE ACCESS ROUTES INTERSECT PAVED PUBLIC ROADS, PROVISIONS SHALL BE MADE TO MINIMIZE THE TRANSPORT OF SEDIMENT BY TRACKING ONTO THE PAVED SURFACE. WHERE SEDIMENT IS TRANSPORTED ONTO A PUBLIC ROAD SURFACE WITH CURBS AND GUTTERS, THE ROAD SHALL BE CLEANED THOROUGHLY AT THE END OF EACH DAY. SEDIMENT SHALL BE REMOVED FROM THE ROADS BY SHOVELING OR SWEEPING AND TRANSPORTED TO A SEDIMENT CONTROL DISPOSAL AREA. STREET WASHING SHALL BE ALLOWED ONLY AFTER SEDIMENT IS REMOVED IN THIS MANNER. THIS PROVISION SHALL APPLY TO INDIVIDUAL SUBDIVISION LOTS AS WELL AS TO LARGER LAND-DISTURBING ACTIVITIES.
18. ALL TEMPORARY EROSION AND SEDIMENT CONTROL MEASURES SHALL BE REMOVED WITHIN 30 DAYS AFTER FINAL SITE STABILIZATION OR AFTER THE TEMPORARY MEASURES ARE NO LONGER NEEDED, IN THE OPINION OF THE REVIEWER. DISTURBED SOIL AREAS RESULTING FROM THE DISPOSITION OF TEMPORARY MEASURES SHALL BE PERMANENTLY STABILIZED TO PREVENT FURTHER EROSION AND SEDIMENTATION.
19. PROPERTIES AND WATERWAYS DOWNSTREAM FROM CONSTRUCTION SITE SHALL BE PROTECTED FROM SEDIMENT DISPOSITION AND EROSION.
20. EROSION CONTROL DESIGN AND CONSTRUCTION SHALL FOLLOW THE REQUIREMENTS IN INDEX NOS. 104 AND 105 OF FDOT ROADWAY AND TRAFFIC DESIGN STANDARDS.
21. THE REVIEWER MAY APPROVE MODIFICATIONS OR ALTER PLANS TO THESE EROSION CONTROL CRITERIA DUE TO SITE SPECIFIC CONDITIONS.

REVISIONS	DATE	JOB NO.
---	---	21-0311
---	---	DESIGNED TH
---	---	DRAWN SS
---	---	DATE DEC. 2021
---	---	CHECKED AS
PER FDEP RAI #1 COMMENTS	09/09/2022	
PER SURJMD FIELD INSPECTION	08/23/2022	DATE ISSUED 08/11/2022

MBV
ENGINEERING, INC.
MOIRA BOWLES VILLAMIZAR & ASSOCIATES
CONSULTING ENGINEERING CA #3728

1835 20TH STREET
VERO BEACH, FL 32960
PH. (772) 569-0035
FX. (772) 778-3617
MELBOURNE, FL - PH (321) 253-1510
FT. PIERCE, FL - PH (772) 468-9065

INDIAN RIVER COUNTY

HISTORIC TRANS-FLORIDA RAIL
TRAIL PHASE 2 EXTENSION

FLORIDA

EROSION CONTROL DETAILS

DATE:

SHEET

C16

21-0311

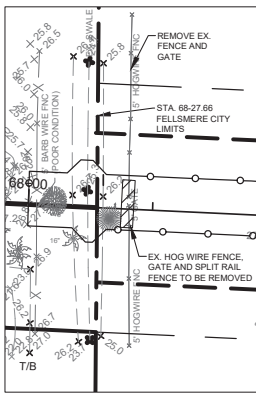

**EXISTING TRAIL
STA. 68+40.42**

SCALE: 1" = 50'

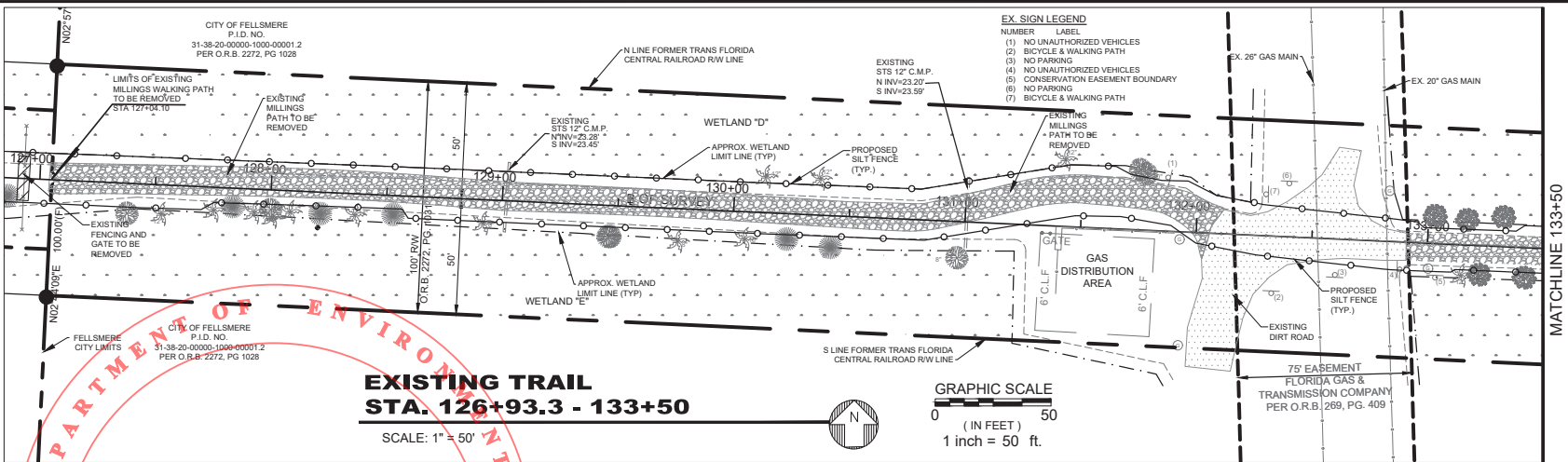
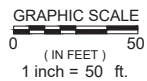

**EXISTING TRAIL
STA. 126+93.3 - 133+50**

SCALE: 1" = 50'

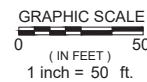

Permit Number

31-0423078-001-SFG

Water Resource
Management

NOTE:
CONTRACTOR TO INSTALL SILT FENCE AROUND EXISTING TREES AS NEEDED TO AVOID CONFLICTS. TO AVOID WETLAND IMPACTS, CONTRACTOR TO LOCATE SILT FENCE ON TRAIL-SIDE OF TREE EXCEPT IN THOSE LOCATIONS WHERE SILT FENCE AND CAN BE LOCATED ON THE BACKSIDE OF TREE WITHOUT IMPACT TO THE WETLAND AREA OR TREE.

LEGEND

- EXISTING MILLINGS TRAIL TO BE REMOVED
- EXISTING WETLAND
- EXISTING WETLAND BOUNDARY
- WETLAND BUFFER
- PROPOSED SILT FENCE
- EXISTING VACATED 100' R/W LINE
- EXISTING FELLSMERE 100' TRAIL EASEMENT
- PROPOSED 60' TRAIL EASEMENT

MATCHLINE 133+50

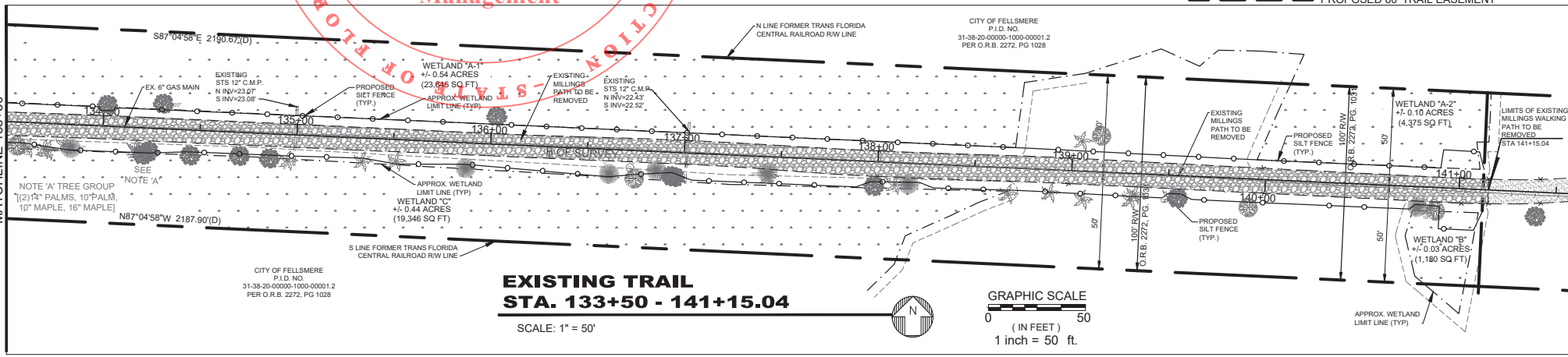

**EXISTING TRAIL
STA. 133+50 - 141+15.04**

SCALE: 1" = 50'

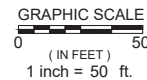

REVISIONS	DATE	JOB NO.	21-0311
DESIGNED	TH		
DRAWN	SS		
DATE	DEC. 2021		
CHECKED	AS		
PER FDEP RAI #1 COMMENTS	09/09/2022		
PER SJRWMD FIELD INSPECTION	08/23/2022		

MBV
ENGINEERING, INC.
MOYA BOWLES VILLAMIZAR & ASSOCIATES
CONSULTING ENGINEERING CA #3728

1835 20TH STREET
VERO BEACH, FL 32960
PH. (772) 569-0035
FX. (772) 778-3617
MELBOURNE, FL - PH (321) 253-1510
FT. PIERCE, FL - PH (772) 468-9055

HISTORIC TRANS-FLORIDA RAIL
TRAIL PHASE 2 EXTENSION

INDIAN RIVER COUNTY

FLORIDA

DEMOLITION PLAN

DATE: 21-0311

SHEET

C17

MATCHLINE 133+50

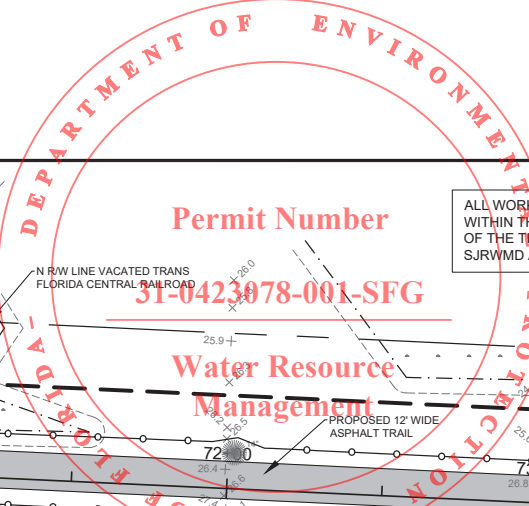

ALL WORK SHALL BE COMPLETED FROM AND WITHIN THE EASEMENTS AND RIGHT-OF-WAYS OF THE THREE AGENCIES (CITY OF FELLSMERE, SJRWMD AND THE STATE OF FLORIDA)

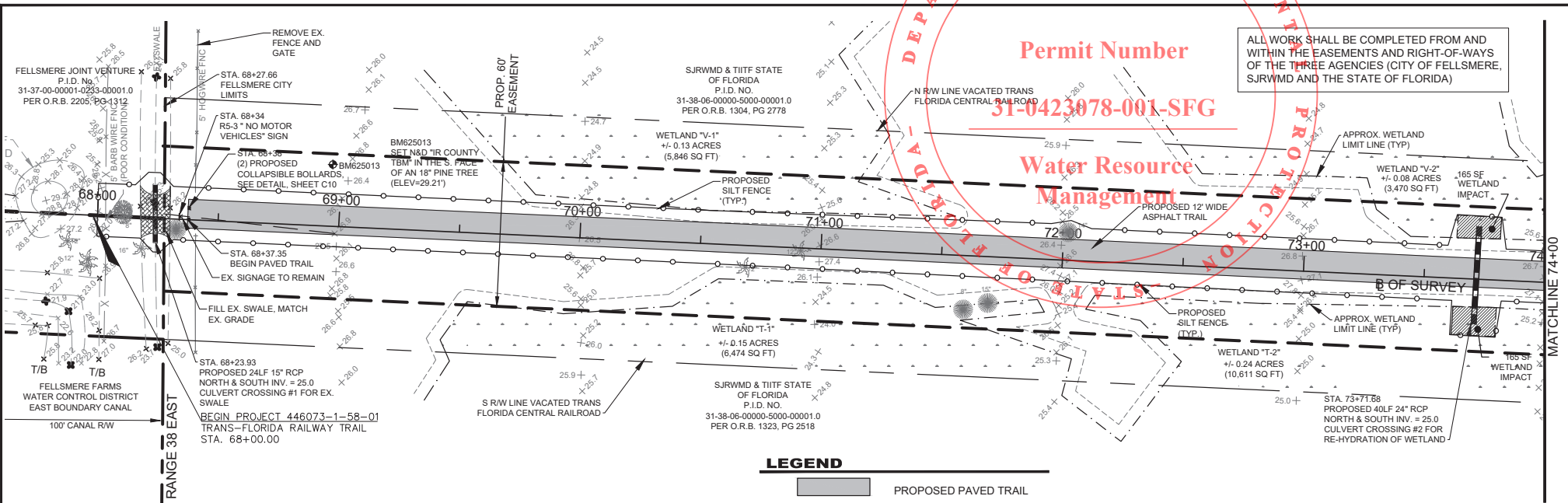

TRAIL PLAN

SCALE: 1" = 40'

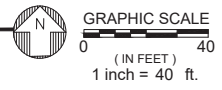

LEGEND

- PROPOSED PAVED TRAIL
- EXISTING WETLAND
- PROPOSED WETLAND IMPACT
- PROPOSED FILL
- EXISTING WETLAND BOUNDARY
- WETLAND BUFFER
- PROPOSED SILT FENCE
- EXISTING VACATED 100' R/W LINE
- PROPOSED 60' TRAIL EASEMENT

NOTE: CONTRACTOR TO INSTALL SILT FENCE AROUND EXISTING TREES AS NEEDED TO AVOID CONFLICTS. TO AVOID WETLAND IMPACTS, CONTRACTOR TO LOCATE SILT FENCE ON TRAIL- SIDE OF TREE EXCEPT IN THOSE LOCATIONS WHERE SILT FENCE AND CAN BE LOCATED ON THE BACKSIDE OF TREE WITHOUT IMPACT TO THE WETLAND AREA OR TREE.

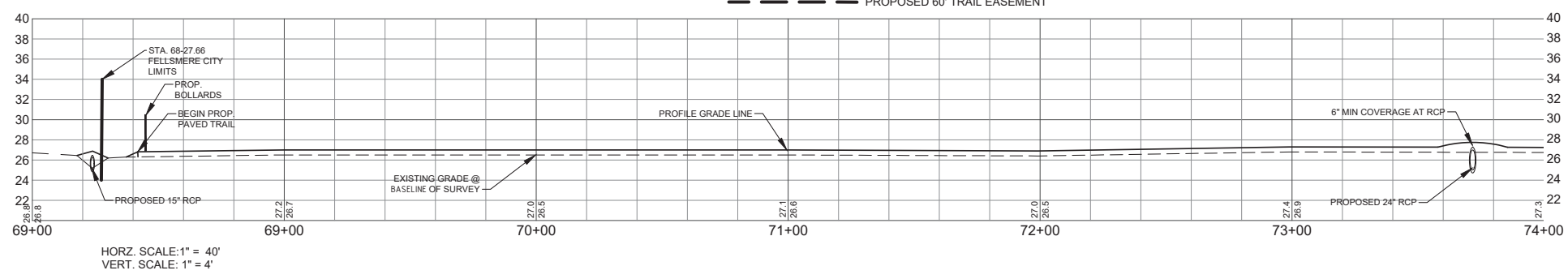

HORZ. SCALE: 1" = 40'
VERT. SCALE: 1" = 4'

REVISIONS	DATE	JOB NO.
		21-0311
		DESIGNED TH
		DRAWN SS
		DATE DEC. 2021
		CHECKED AS
PER FDEP RAI #1 COMMENTS	09/09/2022	
PER SJRWMD FIELD INSPECTION	08/23/2022	
	DATE ISSUED	08/11/2022

MBV ENGINEERING, INC.
 1835 20TH STREET
 VERO BEACH, FL 32960
 PH. (772) 569-0035
 FX. (772) 778-3617

MOJA BOWLES VILLAMIZAR & ASSOCIATES
 CONSULTING ENGINEERING CA #3728
 MELBOURNE, FL - PH (321) 253-1510
 FT. PIERCE, FL - PH (772) 468-9065

HISTORIC TRANS-FLORIDA RAIL
 TRAIL PHASE 2 EXTENSION

INDIAN RIVER COUNTY FLORIDA

PLAN AND PROFILE	SHEET
	C18
DATE:	21-0311

ALL WORK SHALL BE COMPLETED FROM AND WITHIN THE EASEMENTS AND RIGHT-OF-WAYS OF THE THREE AGENCIES (CITY OF FELLSMERE, SJRWMD AND THE STATE OF FLORIDA)

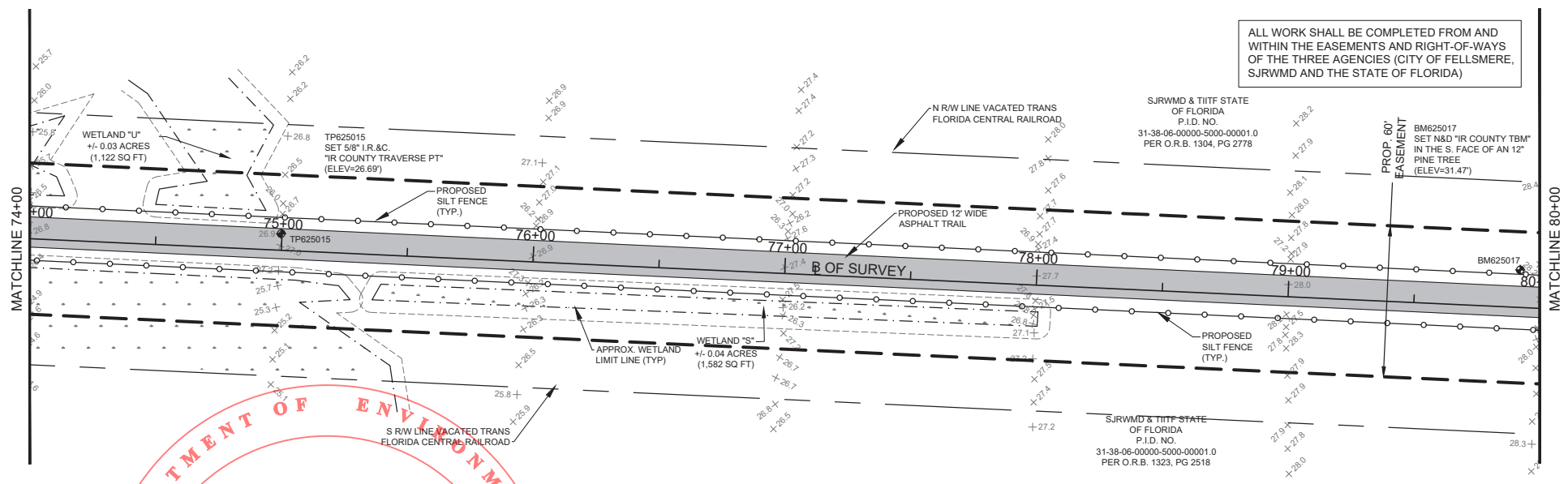

TRAIL PLAN

SCALE: 1" = 40'

Permit Number
31-0423078-001-SFG

Water Resource
Management

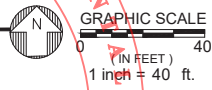

LEGEND

- PROPOSED PAVED TRAIL
- EXISTING WETLAND
- EXISTING WETLAND BOUNDARY
- WETLAND BUFFER
- PROPOSED SILT FENCE
- EXISTING VACATED 100' R/W LINE
- PROPOSED 60' TRAIL EASEMENT

NOTE:
CONTRACTOR TO INSTALL SILT FENCE AROUND EXISTING TREES AS NEEDED TO AVOID CONFLICTS. TO AVOID WETLAND IMPACTS, CONTRACTOR TO LOCATE SILT FENCE ON TRAIL- SIDE OF TREE EXCEPT IN THOSE LOCATIONS WHERE SILT FENCE AND CAN BE LOCATED ON THE BACKSIDE OF TREE WITHOUT IMPACT TO THE WETLAND AREA OR TREE.

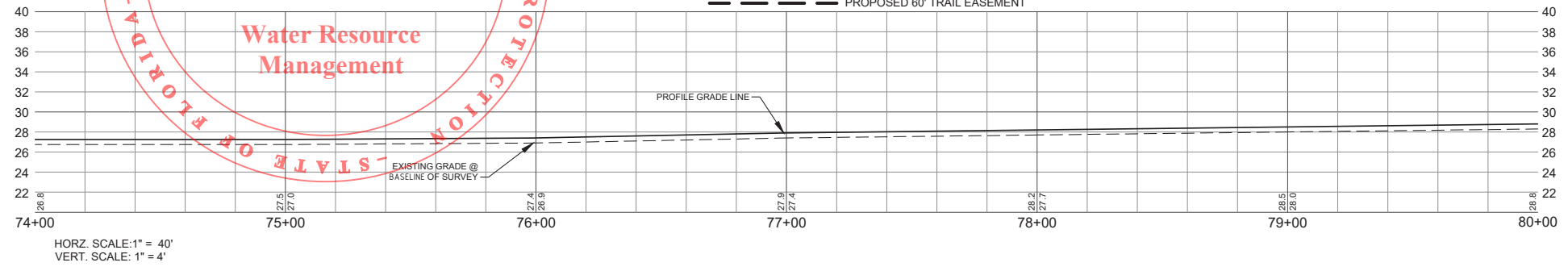

HORZ. SCALE: 1" = 40'
VERT. SCALE: 1" = 4'

REVISIONS	DATE	JOB NO.
DESIGNED	TH	21-0311
DRAWN	SS	
DATE	DEC. 2021	
CHECKED	AS	
PER FDEP RAI #1 COMMENTS	09/09/2022	
PER SJRWMD FIELD INSPECTION	08/23/2022	

MBV ENGINEERING, INC.
1835 20TH STREET
VERO BEACH, FL 32960
PH. (772) 569-0035
FX. (772) 778-3617

MOJA BOWLES VILLAMIZAR & ASSOCIATES
CONSULTING ENGINEERING CA #3728
MELBOURNE, FL - PH (321) 253-1510
FT. PIERCE, FL - PH (772) 468-9065

HISTORIC TRANS-FLORIDA RAIL
TRAIL PHASE 2 EXTENSION

INDIAN RIVER COUNTY FLORIDA

PLAN AND PROFILE	SHEET C19
DATE:	21-0311

ALL WORK SHALL BE COMPLETED FROM AND WITHIN THE EASEMENTS AND RIGHT-OF-WAYS OF THE THREE AGENCIES (CITY OF FELLSMERE, SJRWMD AND THE STATE OF FLORIDA)

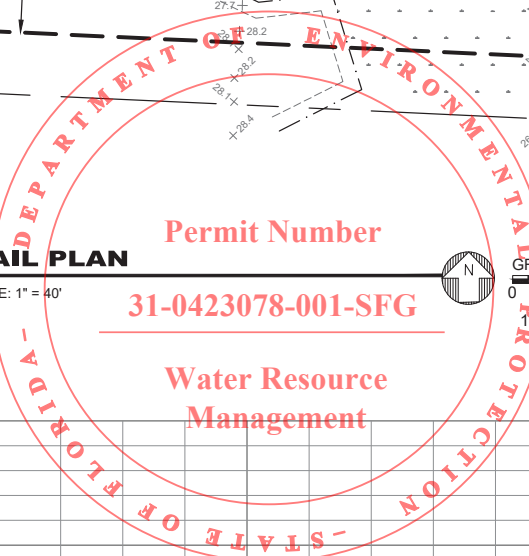
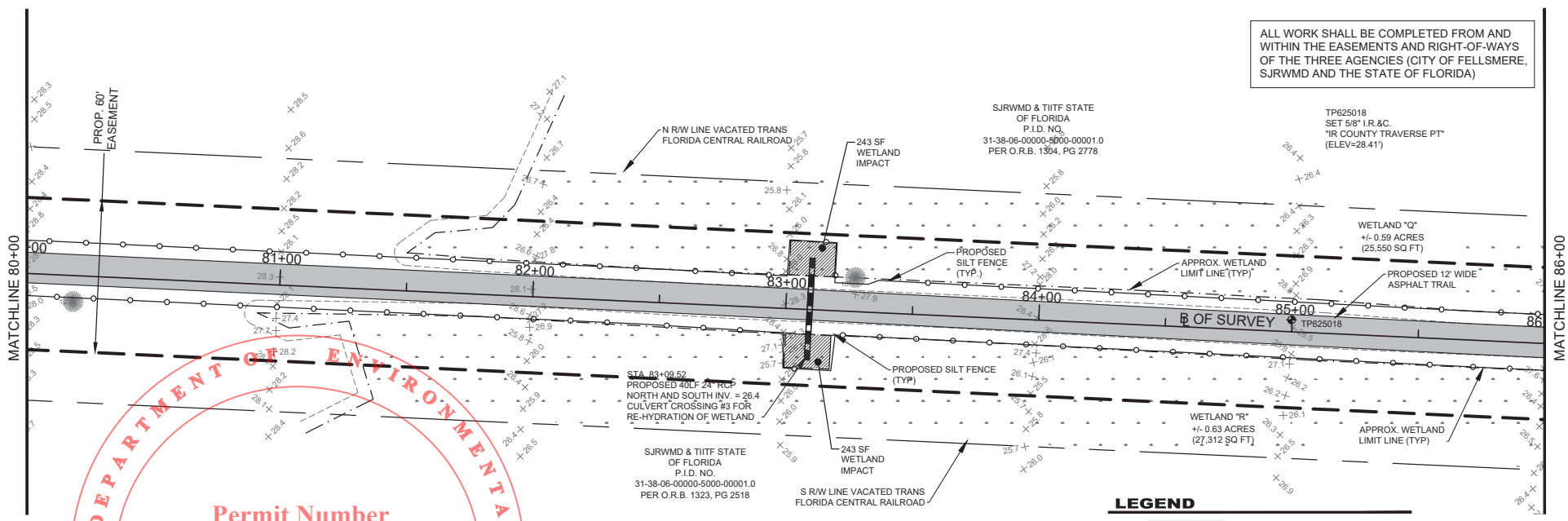

NOTE:
CONTRACTOR TO INSTALL SILT FENCE AROUND EXISTING TREES AS NEEDED TO AVOID CONFLICTS. TO AVOID WETLAND IMPACTS, CONTRACTOR TO LOCATE SILT FENCE ON TRAIL- SIDE OF TREE EXCEPT IN THOSE LOCATIONS WHERE SILT FENCE AND CAN BE LOCATED ON THE BACKSIDE OF TREE WITHOUT IMPACT TO THE WETLAND AREA OR TREE.

LEGEND

	PROPOSED PAVED TRAIL
	EXISTING WETLAND
	PROPOSED WETLAND IMPACT
	EXISTING WETLAND BOUNDARY
	WETLAND BUFFER
	PROPOSED SILT FENCE
	EXISTING VACATED 100' R/W LINE
	PROPOSED 60' TRAIL EASEMENT

TRAIL PLAN
SCALE: 1" = 40'
GRAPHIC SCALE
0 (IN FEET) 40
1 inch = 40 ft.

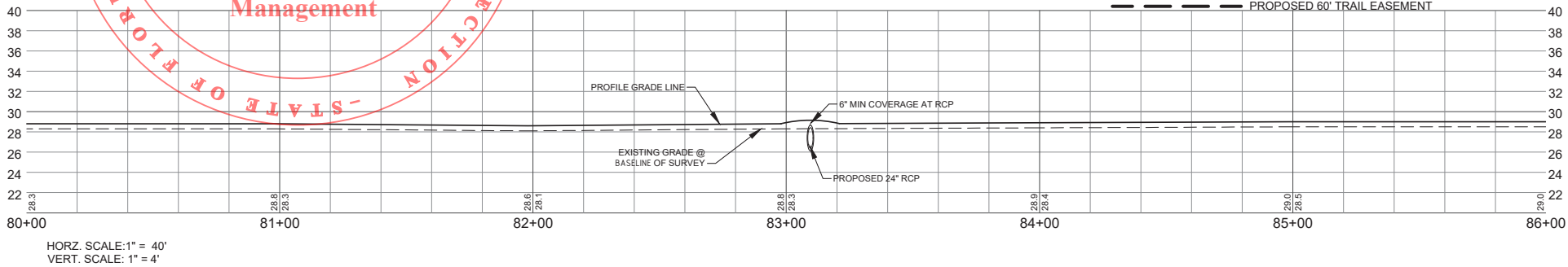

REVISIONS	DATE	JOB NO.
		21-0311
		DESIGNED TH
		DRAWN SS
		DATE DEC. 2021
		CHECKED AS
PER FDEP RAI #1 COMMENTS	09/09/2022	
PER SJRWMD FIELD INSPECTION	08/23/2022	

DATE	08/11/2022
DATE ISSUED	08/11/2022

MBV ENGINEERING, INC.
1835 20TH STREET
VERO BEACH, FL 32960
PH. (772) 569-0035
FX. (772) 778-3617

MELBOURNE, FL - PH (321) 253-1510
FT. PIERCE, FL - PH (772) 468-9065

HISTORIC TRANS-FLORIDA RAIL
TRAIL PHASE 2 EXTENSION
INDIAN RIVER COUNTY
FLORIDA

PLAN AND PROFILE
DATE: 21-0311

SHEET
C20

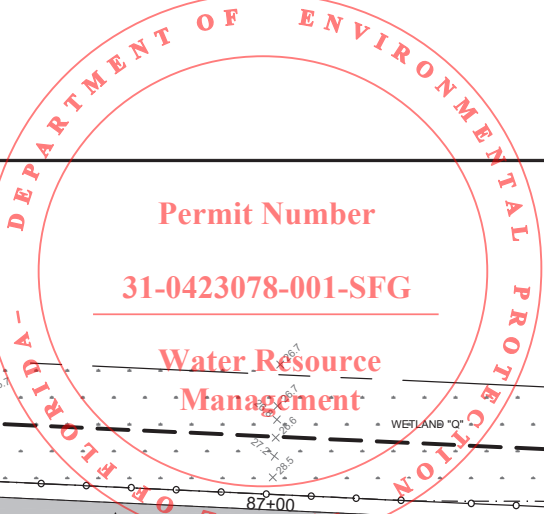

ALL WORK SHALL BE COMPLETED FROM AND WITHIN THE EASEMENTS AND RIGHT-OF-WAYS OF THE THREE AGENCIES (CITY OF FELLSMERE, SJRWMD AND THE STATE OF FLORIDA)

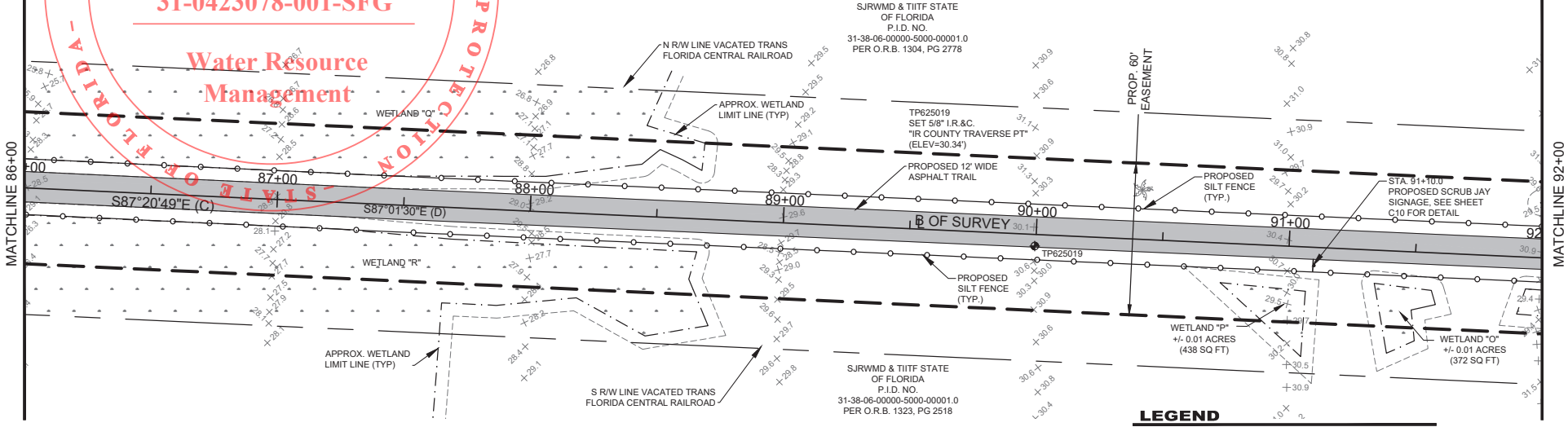

TRAIL PLAN

SCALE: 1" = 40'

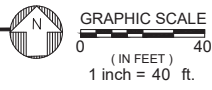

NOTE:
CONTRACTOR TO INSTALL SILT FENCE AROUND EXISTING TREES AS NEEDED TO AVOID CONFLICTS. TO AVOID WETLAND IMPACTS, CONTRACTOR TO LOCATE SILT FENCE ON TRAIL- SIDE OF TREE EXCEPT IN THOSE LOCATIONS WHERE SILT FENCE AND CAN BE LOCATED ON THE BACKSIDE OF TREE WITHOUT IMPACT TO THE WETLAND AREA OR TREE.

LEGEND

- PROPOSED PAVED TRAIL
- EXISTING WETLAND
- EXISTING WETLAND BOUNDARY
- WETLAND BUFFER
- PROPOSED SILT FENCE
- EXISTING VACATED 100' R/W LINE
- PROPOSED 60' TRAIL EASEMENT

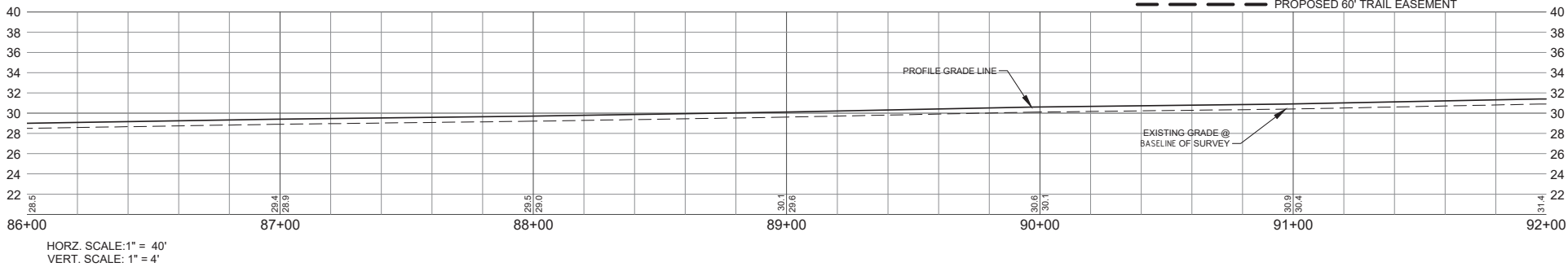

HORZ. SCALE: 1" = 40'
VERT. SCALE: 1" = 4'

REVISIONS	DATE	JOB NO.
△		21-0311
---		DESIGNED TH
---		DRAWN SS
---		DATE DEC. 2021
---		CHECKED AS
△	09/09/2022	PER FDEP RAI #1 COMMENTS
△	08/23/2022	PER SJRWMD FIELD INSPECTION

MBV ENGINEERING, INC.
MOYA BOWLES VILLAMIZAR & ASSOCIATES
CONSULTING ENGINEERING CA #3728

1835 20TH STREET
VERO BEACH, FL 32960
PH. (772) 569-0035
FX. (772) 778-3617

MELBOURNE, FL - PH (321) 253-1510
FT. PIERCE, FL - PH (772) 468-9065

HISTORIC TRANS-FLORIDA RAIL
TRAIL PHASE 2 EXTENSION

INDIAN RIVER COUNTY FLORIDA

PLAN AND PROFILE	SHEET C21
DATE:	21-0311

ALL WORK SHALL BE COMPLETED FROM AND WITHIN THE EASEMENTS AND RIGHT-OF-WAYS OF THE THREE AGENCIES (CITY OF FELLSMERE, SJRWMD AND THE STATE OF FLORIDA)

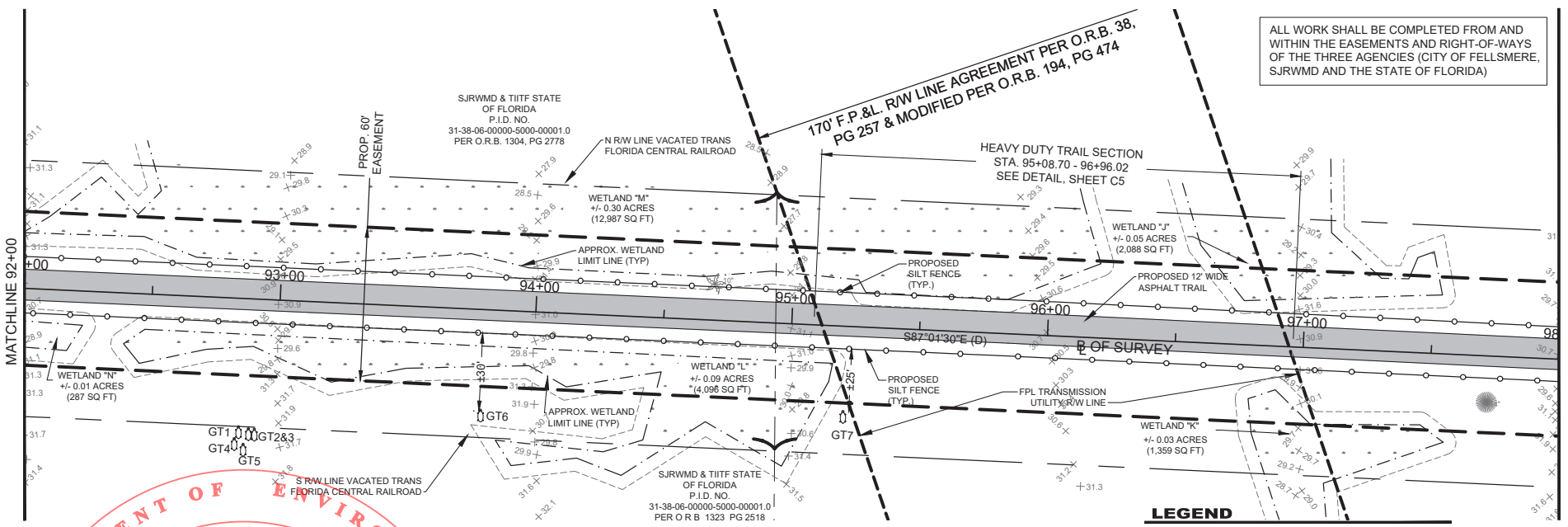

TRAIL PLAN

SCALE: 1" = 40'

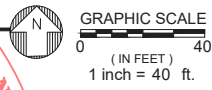

NOTE:
CONTRACTOR TO INSTALL SILT FENCE AROUND EXISTING TREES AS NEEDED TO AVOID CONFLICTS. TO AVOID WETLAND IMPACTS, CONTRACTOR TO LOCATE SILT FENCE ON TRAIL- SIDE OF TREE EXCEPT IN THOSE LOCATIONS WHERE SILT FENCE AND CAN BE LOCATED ON THE BACKSIDE OF TREE WITHOUT IMPACT TO THE WETLAND AREA OR TREE.

LEGEND

- PROPOSED PAVED TRAIL
- EXISTING WETLAND
- EXISTING WETLAND BOUNDARY
- WETLAND BUFFER
- PROPOSED SILT FENCE
- EXISTING VACATED 100' RW LINE
- PROPOSED 60' TRAIL EASEMENT
- GT# GOPHER TORTOISE LOCATION

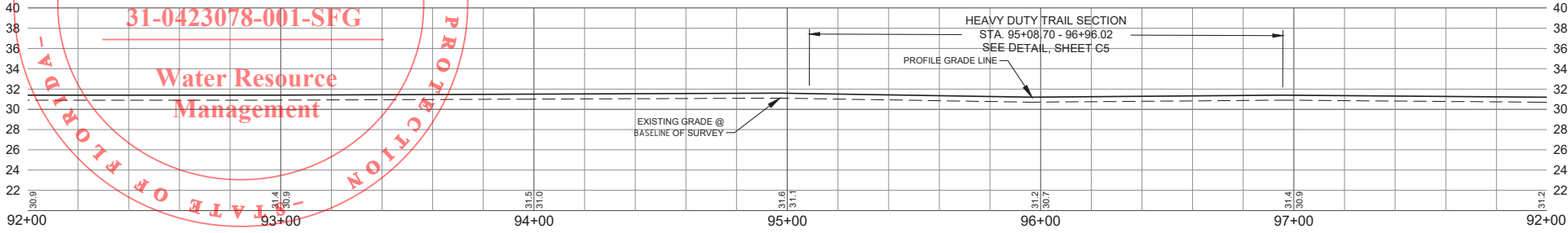

HORZ. SCALE: 1" = 40'
VERT. SCALE: 1" = 4'

REVISIONS	DATE	JOB NO.
DESIGNED	TH	21-0311
DRAWN	SS	
DATE	DEC. 2021	
CHECKED	AS	
PER FDEP RAI #1 COMMENTS	09/09/2022	
PER SJRWMD FIELD INSPECTION	08/23/2022	

MBV ENGINEERING, INC.
 1835 20TH STREET
 VERO BEACH, FL 32960
 PH. (772) 569-0035
 FX. (772) 778-3617

MOJA BOWLES VILLAMIZAR & ASSOCIATES
 CONSULTING ENGINEERING CA #3728
 MELBOURNE, FL - PH (321) 253-1510
 FT. PIERCE, FL - PH (772) 468-9065

HISTORIC TRANS-FLORIDA RAIL
 TRAIL PHASE 2 EXTENSION
 INDIAN RIVER COUNTY
 FLORIDA

PLAN AND PROFILE	SHEET C22
DATE:	21-0311

ALL WORK SHALL BE COMPLETED FROM AND WITHIN THE EASEMENTS AND RIGHT-OF-WAYS OF THE THREE AGENCIES (CITY OF FELLSMERE, SJRWMD AND THE STATE OF FLORIDA)

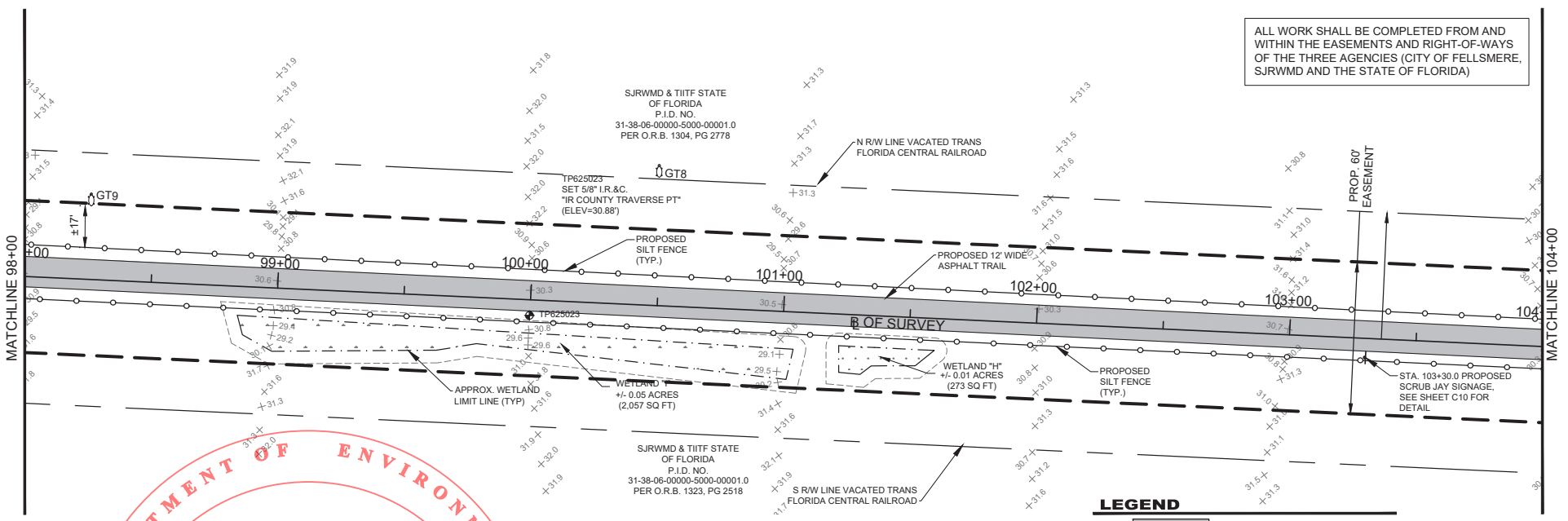

TRAIL PLAN

SCALE: 1" = 40'
 GRAPHIC SCALE
 (IN FEET) 40
 1 inch = 40 ft.

NOTE:
 CONTRACTOR TO INSTALL SILT FENCE AROUND EXISTING TREES AS NEEDED TO AVOID CONFLICTS. TO AVOID WETLAND IMPACTS, CONTRACTOR TO LOCATE SILT FENCE ON TRAIL- SIDE OF TREE EXCEPT IN THOSE LOCATIONS WHERE SILT FENCE AND CAN BE LOCATED ON THE BACKSIDE OF TREE WITHOUT IMPACT TO THE WETLAND AREA OR TREE.

LEGEND

- PROPOSED PAVED TRAIL
- EXISTING WETLAND
- EXISTING WETLAND BOUNDARY
- WETLAND BUFFER
- PROPOSED SILT FENCE
- EXISTING VACATED 100' R/W LINE
- PROPOSED 60' TRAIL EASEMENT
- GOPHER TORTOISE LOCATION

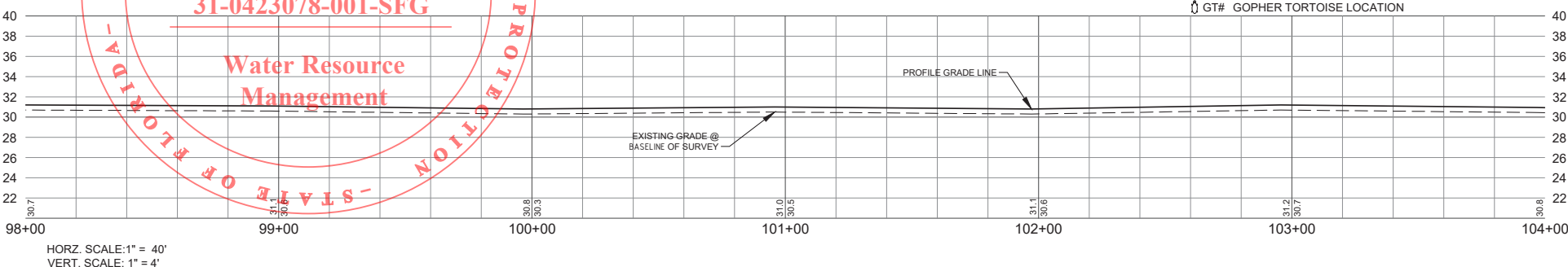
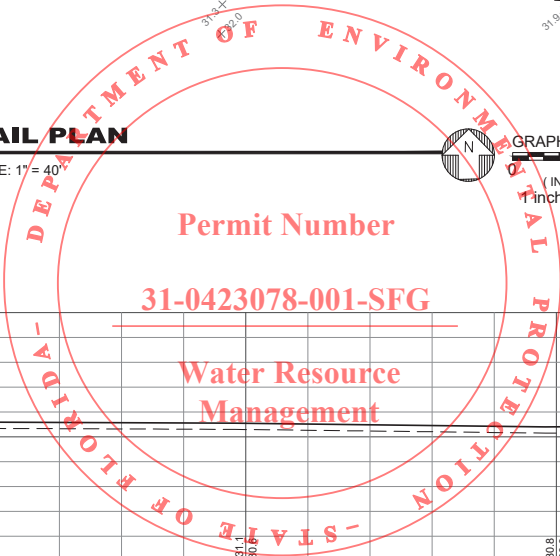

HORZ. SCALE: 1" = 40'
 VERT. SCALE: 1" = 4'

<table border="1"> <thead> <tr> <th>REVISIONS</th> <th>DATE</th> <th>JOB NO.</th> </tr> </thead> <tbody> <tr> <td> </td> <td> </td> <td>21-0311</td> </tr> <tr> <td> </td> <td> </td> <td>DESIGNED TH</td> </tr> <tr> <td> </td> <td> </td> <td>DRAWN SS</td> </tr> <tr> <td> </td> <td> </td> <td>DATE DEC. 2021</td> </tr> <tr> <td> </td> <td> </td> <td>CHECKED AS</td> </tr> <tr> <td> </td> <td> </td> <td>DATE ISSUED 08/11/2022</td> </tr> </tbody> </table>	REVISIONS	DATE	JOB NO.			21-0311			DESIGNED TH			DRAWN SS			DATE DEC. 2021			CHECKED AS			DATE ISSUED 08/11/2022	<p>MBV ENGINEERING, INC. MOYA BOWLES VILLAMIZAR & ASSOCIATES CONSULTING ENGINEERING CA #3728</p>	<p>1835 20TH STREET VERO BEACH, FL 32960 PH. (772) 569-0035 FX. (772) 778-3617</p>	<p>HISTORIC TRANS-FLORIDA RAIL TRAIL PHASE 2 EXTENSION</p>	<p>INDIAN RIVER COUNTY</p>	<p>FLORIDA</p>	<p>PLAN AND PROFILE</p>	<p>DATE: 21-0311</p>	<p>SHEET C23</p>
REVISIONS	DATE	JOB NO.																											
		21-0311																											
		DESIGNED TH																											
		DRAWN SS																											
		DATE DEC. 2021																											
		CHECKED AS																											
		DATE ISSUED 08/11/2022																											

ALL WORK SHALL BE COMPLETED FROM AND WITHIN THE EASEMENTS AND RIGHT-OF-WAYS OF THE THREE AGENCIES (CITY OF FELLSMERE, SJRWMD AND THE STATE OF FLORIDA)

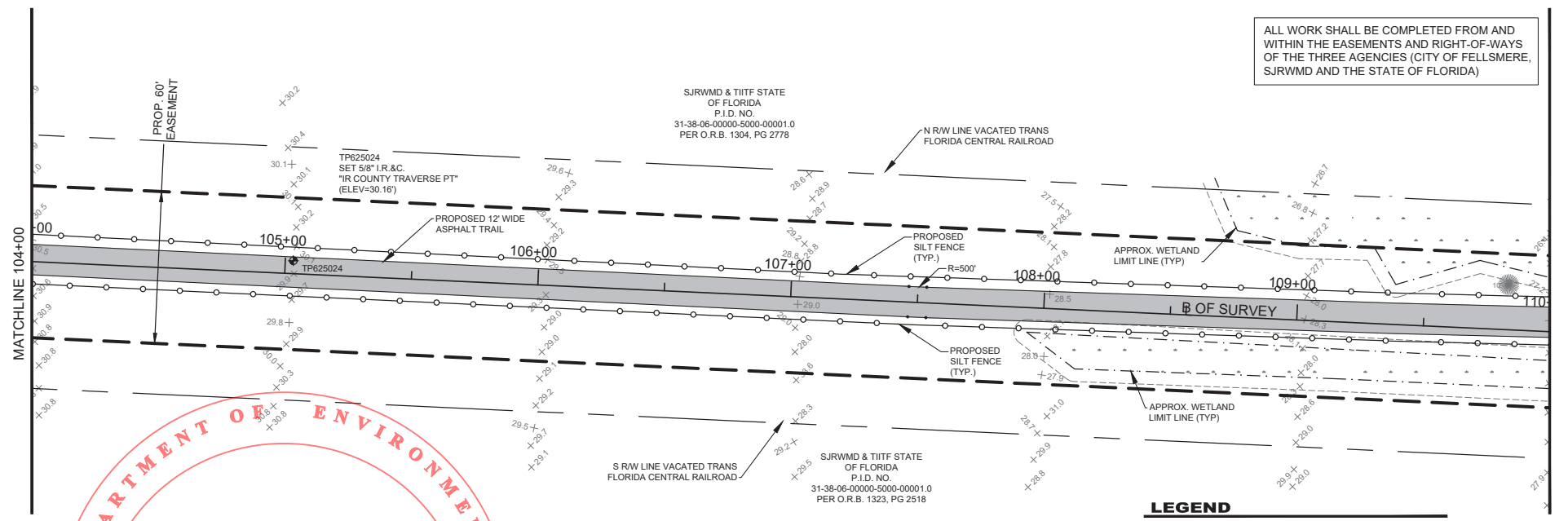

LEGEND

	PROPOSED PAVED TRAIL
	EXISTING WETLAND
	EXISTING WETLAND BOUNDARY
	WETLAND BUFFER
	PROPOSED SILT FENCE
	EXISTING VACATED 100' R/W LINE
	PROPOSED 60' TRAIL EASEMENT

NOTE:
 CONTRACTOR TO INSTALL SILT FENCE AROUND EXISTING TREES AS NEEDED TO AVOID CONFLICTS. TO AVOID WETLAND IMPACTS, CONTRACTOR TO LOCATE SILT FENCE ON TRAIL- SIDE OF TREE EXCEPT IN THOSE LOCATIONS WHERE SILT FENCE AND CAN BE LOCATED ON THE BACKSIDE OF TREE WITHOUT IMPACT TO THE WETLAND AREA OR TREE.

TRAIL PLAN
 SCALE: 1" = 40'
 GRAPHIC SCALE
 (IN FEET) 40
 inch = 40 ft.

Permit Number
31-0423078-001-SFG
Water Resource Management

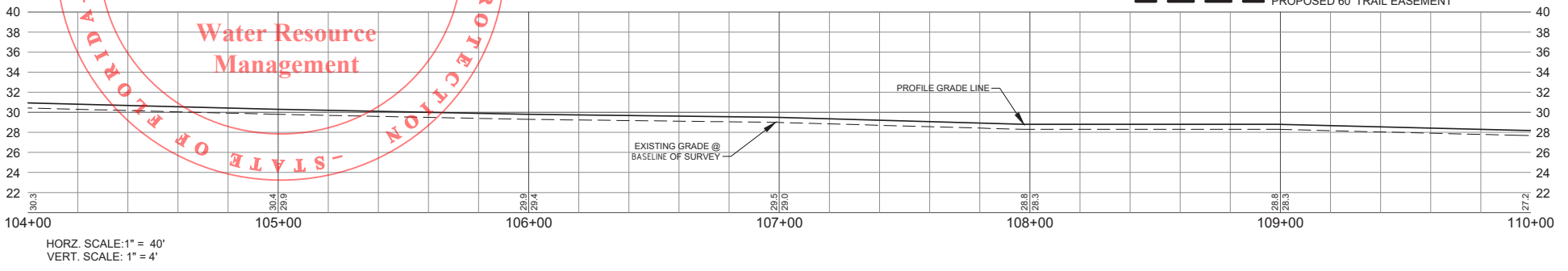

HORZ. SCALE: 1" = 40'
 VERT. SCALE: 1" = 4'

REVISIONS	DATE	JOB NO.
DESIGNED	TH	21-0311
DRAWN	SS	
DATE	DEC. 2021	
CHECKED	AS	
DATE ISSUED	08/11/2022	

MBV ENGINEERING, INC.
 1835 20TH STREET
 VERO BEACH, FL 32960
 PH. (772) 569-0035
 FX. (772) 778-3617
 MELBOURNE, FL - PH (321) 253-1510
 FT. PIERCE, FL - PH (772) 468-9065

HISTORIC TRANS-FLORIDA RAIL
 TRAIL PHASE 2 EXTENSION
 INDIAN RIVER COUNTY
 FLORIDA

PLAN AND PROFILE	SHEET C24
DATE:	21-0311

ALL WORK SHALL BE COMPLETED FROM AND WITHIN THE EASEMENTS AND RIGHT-OF-WAYS OF THE THREE AGENCIES (CITY OF FELLSMERE, SJRWMD AND THE STATE OF FLORIDA)

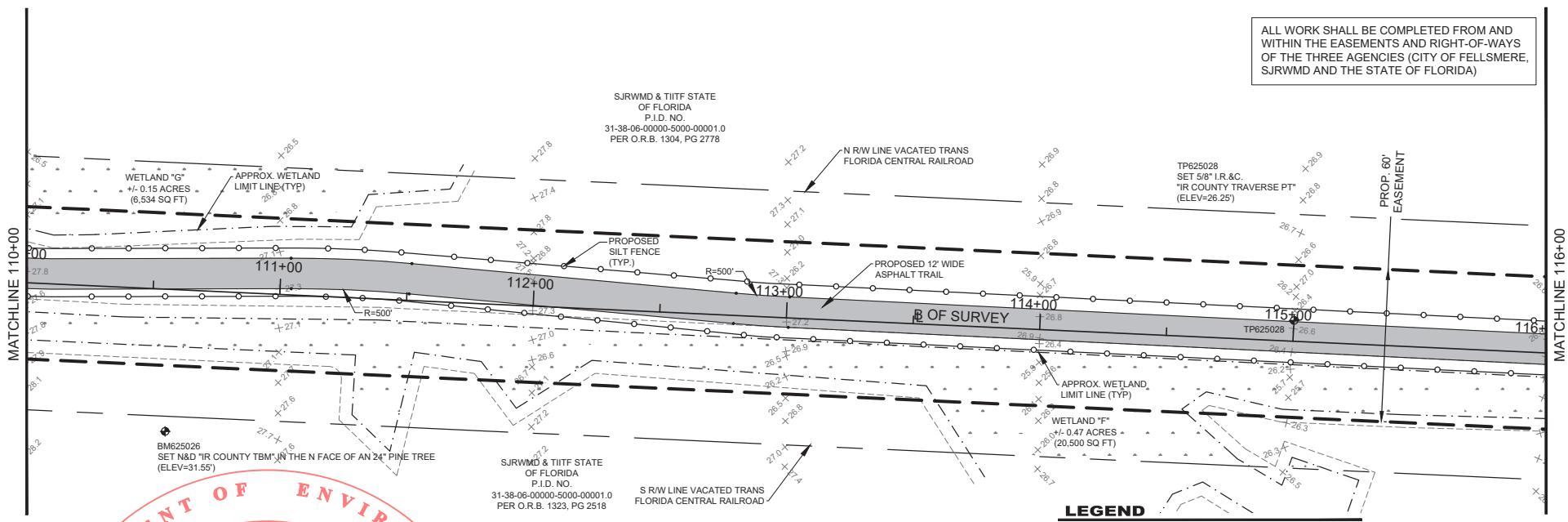

TRAIL PLAN

SCALE: 1" = 40'

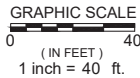

NOTE:
 CONTRACTOR TO INSTALL SILT FENCE AROUND EXISTING TREES AS NEEDED TO AVOID CONFLICTS. TO AVOID WETLAND IMPACTS, CONTRACTOR TO LOCATE SILT FENCE ON TRAIL- SIDE OF TREE EXCEPT IN THOSE LOCATIONS WHERE SILT FENCE AND CAN BE LOCATED ON THE BACKSIDE OF TREE WITHOUT IMPACT TO THE WETLAND AREA OR TREE.

LEGEND

- PROPOSED PAVED TRAIL
- EXISTING WETLAND
- EXISTING WETLAND BOUNDARY
- WETLAND BUFFER
- PROPOSED SILT FENCE
- EXISTING VACATED 100' R/W LINE
- PROPOSED 60' TRAIL EASEMENT

Permit Number

31-0423078-001-SFG

Water Resource
 Management

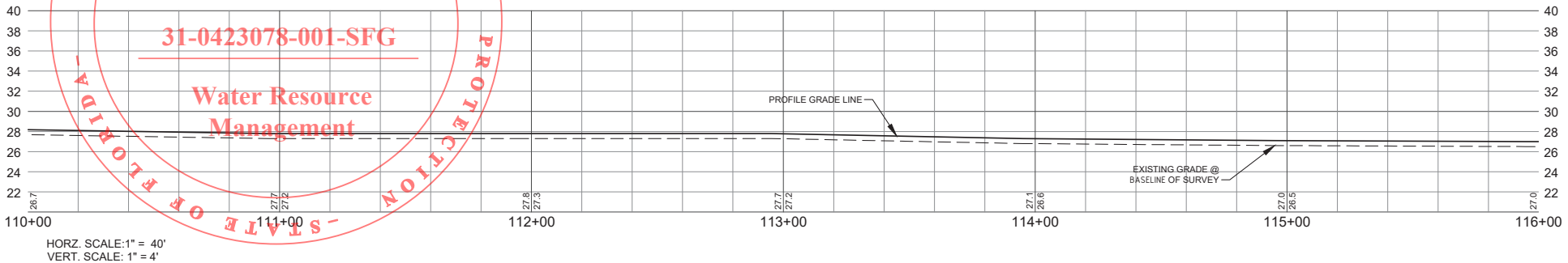

HORZ. SCALE: 1" = 40'
 VERT. SCALE: 1" = 4'

REVISIONS	DATE	JOB NO.	21-0311
DESIGNED	TH		
DRAWN	SS		
DATE	DEC. 2021		
CHECKED	AS		
PER FDEP RAI #1 COMMENTS	09/09/2022		
PER SJRWMD FIELD INSPECTION	08/23/2022		

MBV
ENGINEERING, INC.
 MOYA BOWLES VILLAMIZAR & ASSOCIATES
 CONSULTING ENGINEERING CA #3728

1835 20TH STREET
 VERO BEACH, FL 32960
 PH. (772) 569-0035
 FX. (772) 778-3617
 MELBOURNE, FL - PH (321) 253-1510
 FT. PIERCE, FL - PH (772) 468-9055

HISTORIC TRANS-FLORIDA RAIL
 TRAIL PHASE 2 EXTENSION

INDIAN RIVER COUNTY

FLORIDA

PLAN AND PROFILE

DATE: 21-0311

SHEET
C25

ALL WORK SHALL BE COMPLETED FROM AND WITHIN THE EASEMENTS AND RIGHT-OF-WAYS OF THE THREE AGENCIES (CITY OF FELLSMERE, SJRWMD AND THE STATE OF FLORIDA)

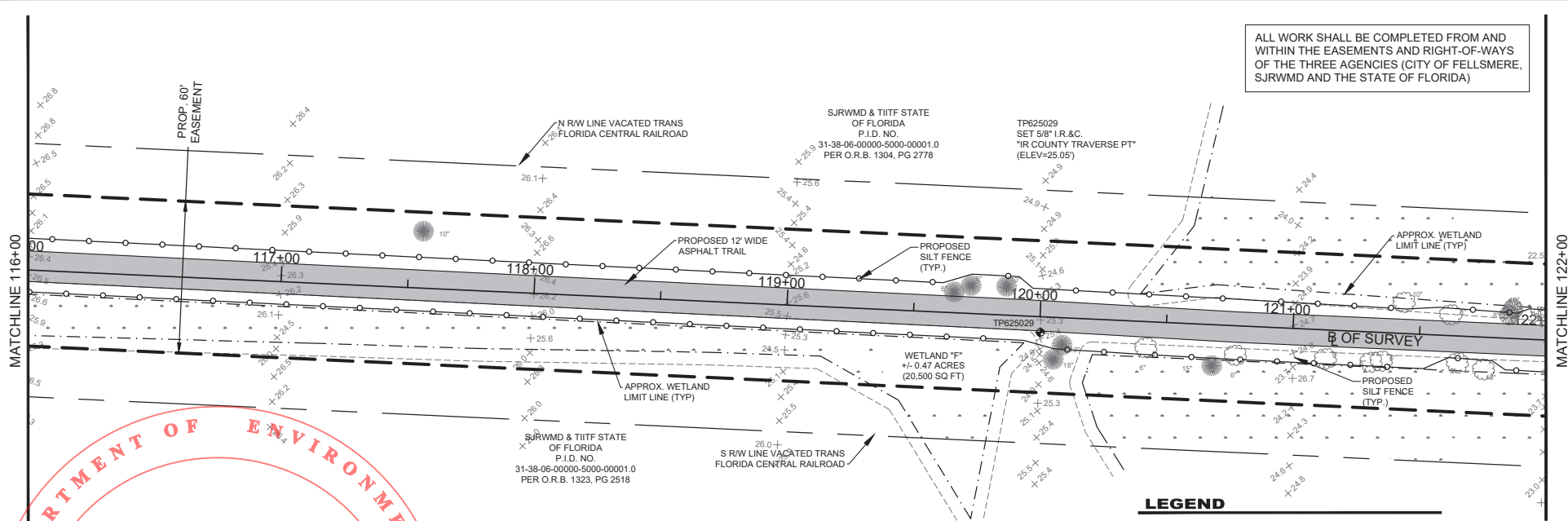

TRAIL PLAN
 SCALE: 1" = 40'
Permit Number
31-0423078-001-SFG
Water Resource Management

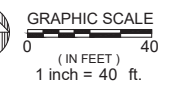

NOTE:
 CONTRACTOR TO INSTALL SILT FENCE AROUND EXISTING TREES AS NEEDED TO AVOID CONFLICTS. TO AVOID WETLAND IMPACTS, CONTRACTOR TO LOCATE SILT FENCE ON TRAIL- SIDE OF TREE EXCEPT IN THOSE LOCATIONS WHERE SILT FENCE AND CAN BE LOCATED ON THE BACKSIDE OF TREE WITHOUT IMPACT TO THE WETLAND AREA OR TREE.

- LEGEND**
- PROPOSED PAVED TRAIL
 - EXISTING WETLAND
 - EXISTING WETLAND BOUNDARY
 - WETLAND BUFFER
 - PROPOSED SILT FENCE
 - EXISTING VACATED 100' R/W LINE
 - PROPOSED 60' TRAIL EASEMENT

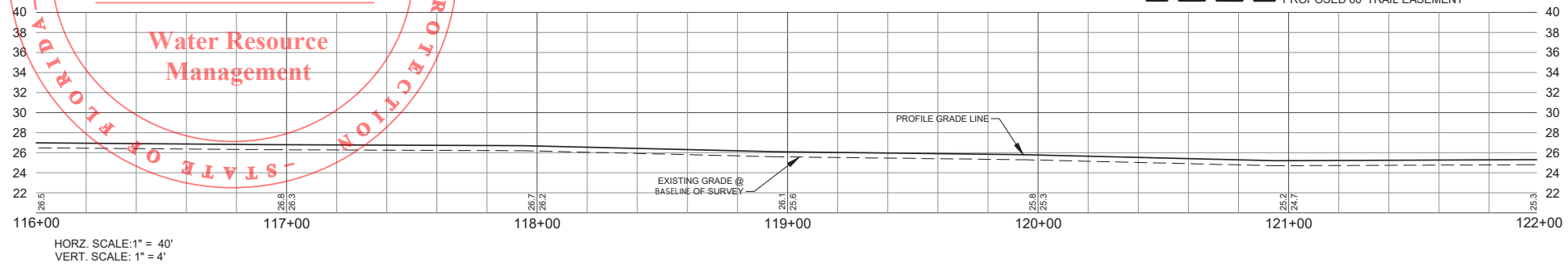

REVISIONS	DATE	JOB NO.
		21-0311
		DESIGNED TH
		DRAWN SS
		DATE DEC. 2021
		CHECKED AS
PER FDEP RAI #1 COMMENTS	09/09/2022	
PER SJRWMD FIELD INSPECTION	08/23/2022	

MBV ENGINEERING, INC.
 MOYA BOWLES VILLAMIZAR & ASSOCIATES
 CONSULTING ENGINEERING CA #3728

1835 20TH STREET
 VERO BEACH, FL 32960
 PH. (772) 569-0035
 FX. (772) 778-3617

MELBOURNE, FL - PH (321) 253-1510
 FT. PIERCE, FL - PH (772) 468-9055

HISTORIC TRANS-FLORIDA RAIL
 TRAIL PHASE 2 EXTENSION

INDIAN RIVER COUNTY FLORIDA

PLAN AND PROFILE

DATE: 21-0311

SHEET
C26

ALL WORK SHALL BE COMPLETED FROM AND WITHIN THE EASEMENTS AND RIGHT-OF-WAYS OF THE THREE AGENCIES (CITY OF FELLSMERE, SJRWMD AND THE STATE OF FLORIDA)

- EX. SIGN LEGEND**
- | NUMBER | LABEL |
|--------|--------------------------------|
| (1) | NO UNAUTHORIZED VEHICLES |
| (2) | BICYCLE & WALKING PATH |
| (3) | NO PARKING |
| (4) | NO UNAUTHORIZED VEHICLES |
| (5) | CONSERVATION EASEMENT BOUNDARY |
| (6) | NO PARKING |
| (7) | BICYCLE & WALKING PATH |

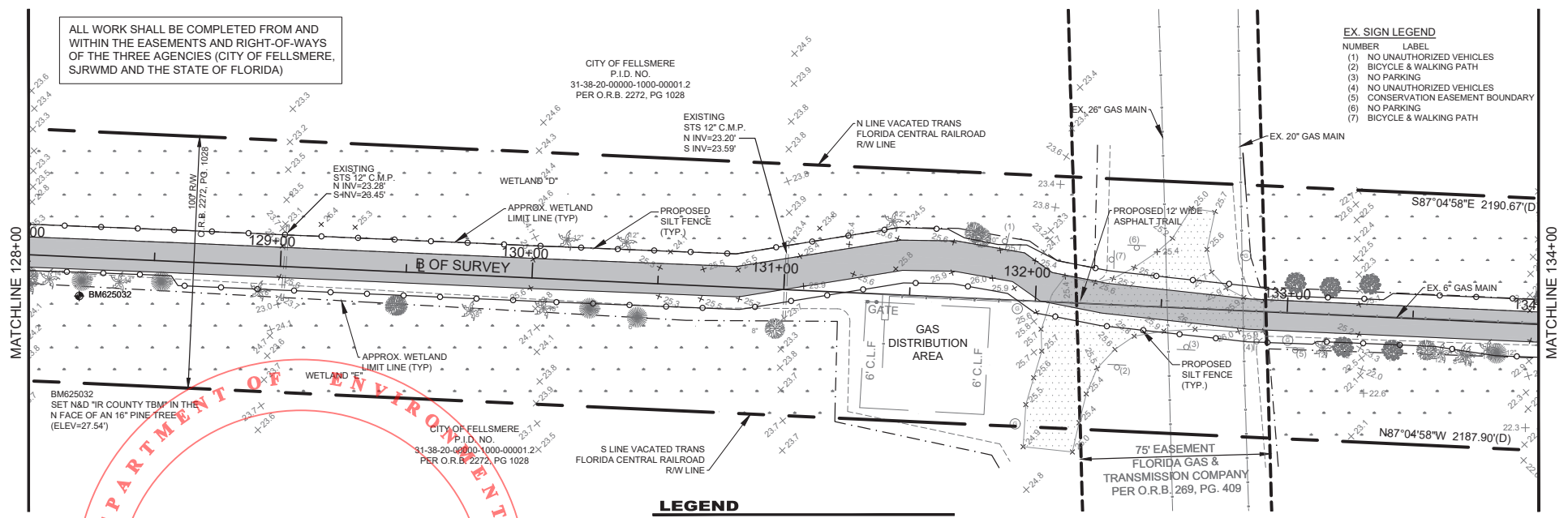

LEGEND

- PROPOSED PAVED TRAIL
- EXISTING WETLAND
- EXISTING WETLAND BOUNDARY
- WETLAND BUFFER
- PROPOSED SILT FENCE
- EXISTING CITY OF FELLSMERE 100' TRAIL EASEMENT

NOTE:
 CONTRACTOR TO INSTALL SILT FENCE AROUND EXISTING TREES AS NEEDED TO AVOID CONFLICTS. TO AVOID WETLAND IMPACTS, CONTRACTOR TO LOCATE SILT FENCE ON TRAIL-SIDE OF TREE EXCEPT IN THOSE LOCATIONS WHERE SILT FENCE AND CAN BE LOCATED ON THE BACKSIDE OF TREE WITHOUT IMPACT TO THE WETLAND AREA OR TREE.

TRAIL PLAN

Permit Number

31-0423078-001-SFG

Water Resource Management



GRAPHIC SCALE
 0 40
 (IN FEET)
 1 inch = 40 ft.

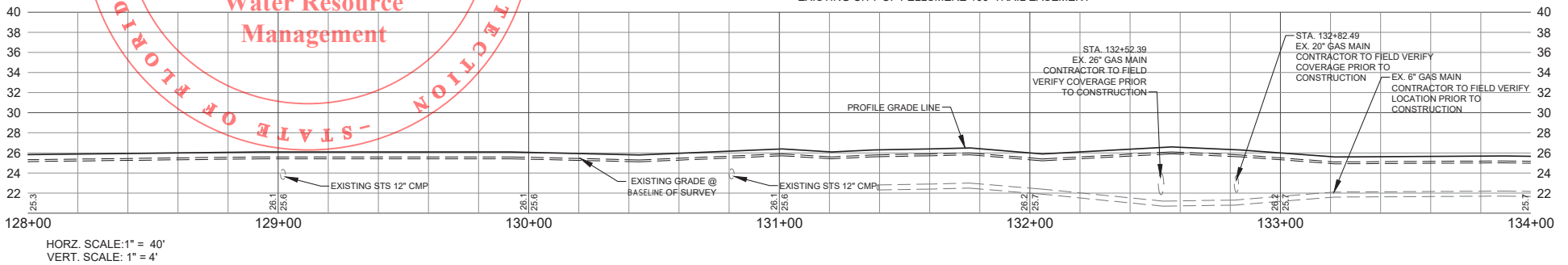

HORZ. SCALE: 1" = 40'
 VERT. SCALE: 1" = 4'

REVISIONS	DATE	JOB NO.
DESIGNED	TH	21-0311
DRAWN	SS	
CHECKED	AS	
DATE ISSUED	08/11/2022	

MBV ENGINEERING, INC.
 MOYA BOWLES VILLAMIZAR & ASSOCIATES
 CONSULTING ENGINEERING CA #3728

1835 20TH STREET
 VERO BEACH, FL 32960
 PH. (772) 569-0035
 FX. (772) 778-3617

MELBOURNE, FL - PH (321) 253-1510
 FT. PIERCE, FL - PH (772) 468-9065

HISTORIC TRANS-FLORIDA RAIL
 TRAIL PHASE 2 EXTENSION

INDIAN RIVER COUNTY FLORIDA

PLAN AND PROFILE	DATE:	21-0311
------------------	-------	---------

SHEET
C28

ALL WORK SHALL BE COMPLETED FROM AND WITHIN THE EASEMENTS AND RIGHT-OF-WAYS OF THE THREE AGENCIES (CITY OF FELLSMERE, SJRWMD AND THE STATE OF FLORIDA)

CITY OF FELLSMERE
P.I.D. NO.
31-38-20-00000-1000-00001.2
PER O.R.B. 2272, PG 1028

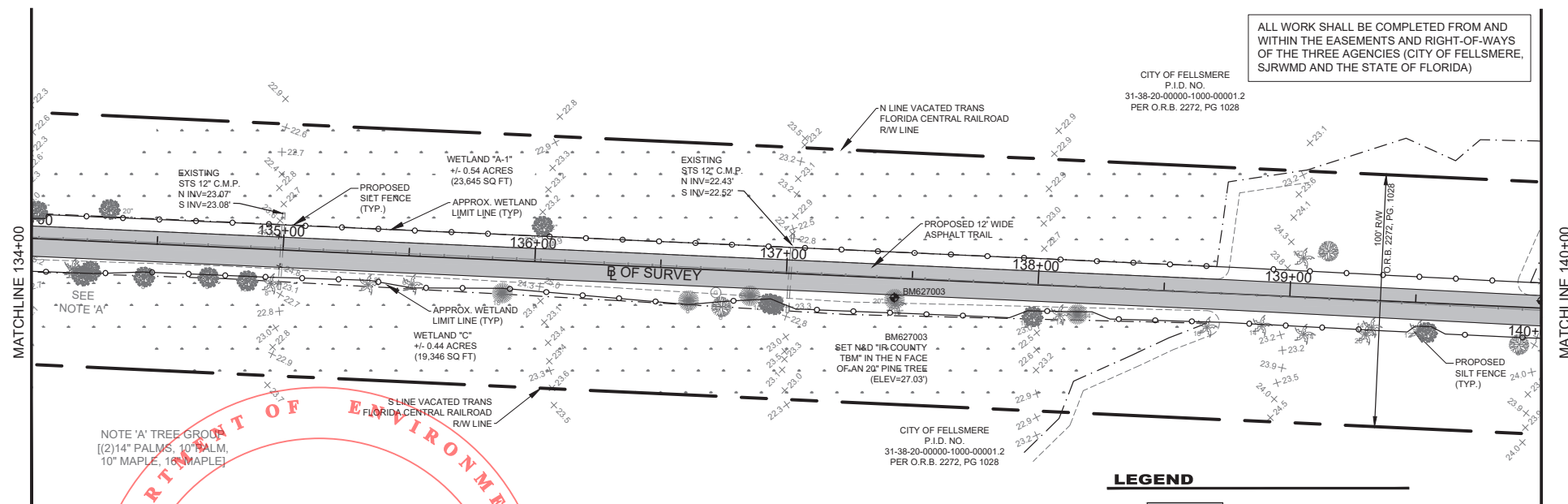

LEGEND

	PROPOSED PAVED TRAIL
	EXISTING WETLAND
	EXISTING WETLAND BOUNDARY
	WETLAND BUFFER
	PROPOSED SILT FENCE
	EXISTING CITY OF FELLSMERE 100' TRAIL EASEMENT

NOTE:
CONTRACTOR TO INSTALL SILT FENCE AROUND EXISTING TREES AS NEEDED TO AVOID CONFLICTS. TO AVOID WETLAND IMPACTS, CONTRACTOR TO LOCATE SILT FENCE ON TRAIL-SIDE OF TREE EXCEPT IN THOSE LOCATIONS WHERE SILT FENCE AND CAN BE LOCATED ON THE BACKSIDE OF TREE WITHOUT IMPACT TO THE WETLAND AREA OR TREE.

TRAIL PLAN

SCALE: 1" = 40'

Permit Number

31-0423078-001-SFG

Water Resource Management

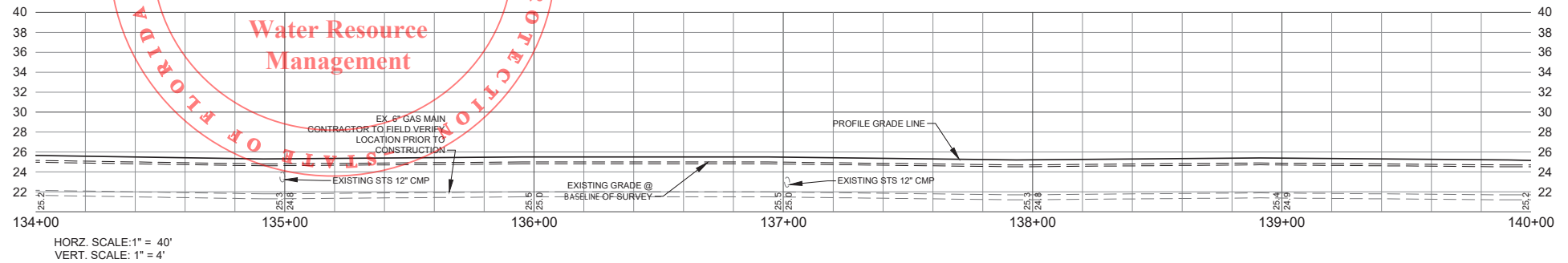
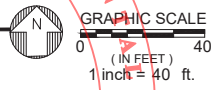

HORZ. SCALE: 1" = 40'
VERT. SCALE: 1" = 4'

REVISIONS	DATE	JOB NO.
DESIGNED	TH	21-0311
DRAWN	SS	
DATE	DEC. 2021	
CHECKED	AS	
PER FDEP RAI #1 COMMENTS	09/09/2022	
PER SJRWMD FIELD INSPECTION	08/23/2022	

MBV ENGINEERING, INC.
MOIWA BOWLES VILLAMIZAR & ASSOCIATES
CONSULTING ENGINEERING CA #3728

1835 20TH STREET
VERO BEACH, FL 32960
PH. (772) 569-0035
FX. (772) 778-3617

MELBOURNE, FL - PH (321) 253-1510
FT. PIERCE, FL - PH (772) 468-9065

HISTORIC TRANS-FLORIDA RAIL
TRAIL PHASE 2 EXTENSION

INDIAN RIVER COUNTY FLORIDA

PLAN AND PROFILE

SHEET
C29

DATE: 21-0311

ALL WORK SHALL BE COMPLETED FROM AND WITHIN THE EASEMENTS AND RIGHT-OF-WAYS OF THE THREE AGENCIES (CITY OF FELLSMERE, SJRWMD AND THE STATE OF FLORIDA)

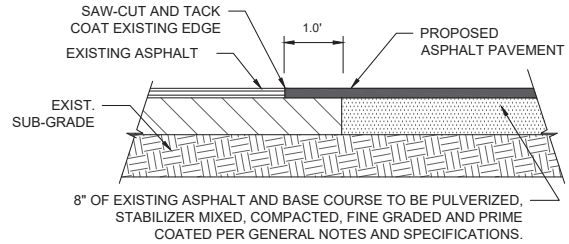
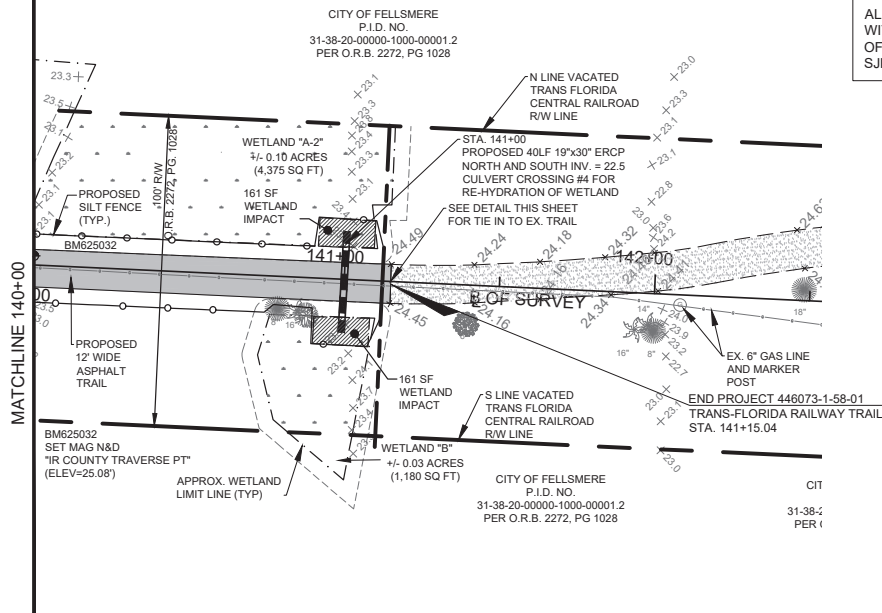

PAVEMENT SAW-CUT AND BUTT JOINT
N.T.S.

TRAIL PLAN

SCALE: 1" = 40'

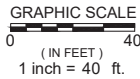

NOTE:
CONTRACTOR TO INSTALL SILT FENCE AROUND EXISTING TREES AS NEEDED TO AVOID CONFLICTS. TO AVOID WETLAND IMPACTS, CONTRACTOR TO LOCATE SILT FENCE ON TRAIL-SIDE OF TREE EXCEPT IN THOSE LOCATIONS WHERE SILT FENCE AND CAN BE LOCATED ON THE BACKSIDE OF TREE WITHOUT IMPACT TO THE WETLAND AREA OR TREE.

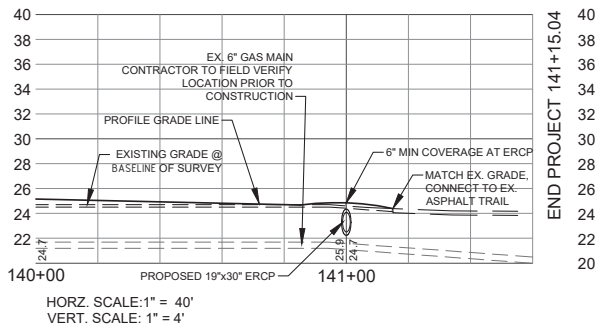

HORZ. SCALE: 1" = 40'
VERT. SCALE: 1" = 4'

LEGEND

- PROPOSED PAVED TRAIL
- EXISTING WETLAND
- PROPOSED WETLAND IMPACT
- EXISTING WETLAND BOUNDARY
- WETLAND BUFFER
- PROPOSED SILT FENCE
- EXISTING CITY OF FELLSMERE 100' TRAIL EASEMENT

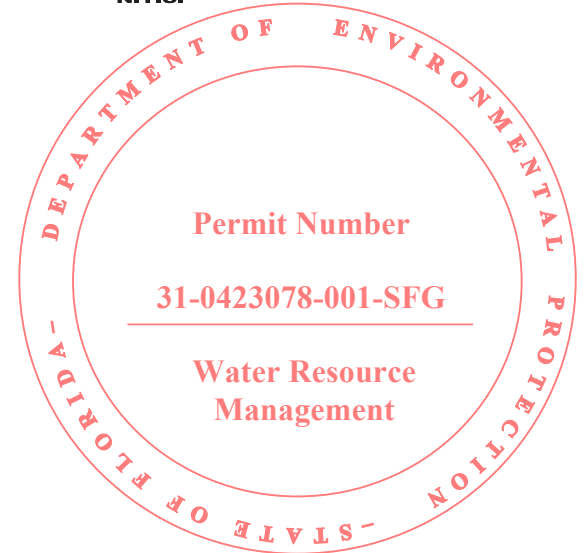

REVISIONS	DATE	JOB NO.
		21-0311
		DESIGNED TH
		DRAWN SS
		DATE DEC. 2021
		CHECKED AS
PER FDEP RAI #1 COMMENTS	09/09/2022	
PER SJRWMD FIELD INSPECTION	08/23/2022	

DATE	DATE ISSUED
	08/11/2022



1835 20TH STREET
VERO BEACH, FL 32960
PH. (772) 569-0035
FX. (772) 778-3617

MELBOURNE, FL - PH (321) 253-1510
FT. PIERCE, FL - PH (772) 468-9065

HISTORIC TRANS-FLORIDA RAIL
TRAIL PHASE 2 EXTENSION

INDIAN RIVER COUNTY

FLORIDA

PLAN AND PROFILE

DATE:

SHEET

C30

21-0311

Certification of Compliance with a State 404 Program General Permit

Instructions: To be completed, executed, and submitted to the Agency within 30 days of completion of the authorized activity.

Permit No: _____ Permittee's Name: _____

Permittee's Address: _____

Telephone Number: _____

Location of the Work: _____

Date Work Started: _____ Date Work Completed: _____

PROPERTY IS INACCESSIBLE WITHOUT PRIOR NOTIFICATION: YES NO
TO SCHEDULE AN INSPECTION, PLEASE CONTACT AT

Description of the Work (e.g., bank stabilization, residential or commercial filling, docks, dredging, etc.):

Acreage or Square Feet of Impacts to state-assumed waters:

Describe Mitigation completed (if applicable):

Describe any Deviations from Permit (attach drawing(s) depicting the deviations):

I certify that all work, and mitigation (if applicable) was done in accordance with the limitations and conditions as described in the permit. Any deviations as described above are depicted on the attached drawing(s).

Signature of Permittee

Date:

Name and Title

Enclosures:

- Attached drawing(s) depicting deviations from the permit (if any)
 Other



St. Johns River Water Management District

Michael A. Register, P.E., Executive Director

4049 Reid Street • P.O. Box 1429 • Palatka, FL 32178-1429 • 386-329-4500 • www.sjrwmd.com

February 21, 2023

Aaron Stanton, P.E. - *Sent via email:* aarons@mbveng.com
MBV Engineering, Inc

Re: Rails to Trails, PDEX: 192063-1
(Please reference the permit number/item number on all correspondence.)

Dear Mr. Stanton:

On September 22, 2022, the St. Johns River Water Management District received your application, construction plans, and determination fee requesting an exemption verification for the above referenced project. Based on this submittal, the proposed project involves the construction of a 12-foot wide multi-use trail from Fellsmere to just west of I-95 on the north side of SR 512.

Pursuant to 62-330.051(9)(b), and 62-330.051(10)(c), Florida Administrative Code (F.A.C.), an Environmental Resource Permit is not required since the project meets the exemption requirements.

Please be advised that this determination only applies to the District and does not relieve you from the permitting requirements of other agencies.

Thank you for your cooperation with the permitting and compliance process. If you have any questions, please contact the District at (321) 409-2185 or by email at PJenning@sjrwmd.com.

Sincerely,

Nanette Church
Supervising Regulatory Scientist
Division of Regulatory Services

CC: Regulatory File
James Ennis, P.E. - *Sent via email:* jennis@ircgov.com
Indian River County

GOVERNING BOARD

Rob Bradley, CHAIR
FLEMING ISLAND

Ryan Atwood
MOUNT DORA

Maryam H. Ghyabi-White, VICE CHAIR
ORMOND BEACH

Doug Bourmique
VERO BEACH

J. Chris Peterson, SECRETARY
WINTER PARK

Douglas Burnett
ST. AUGUSTINE

Cole Oliver
MERRITT ISLAND

Ron Howse, TREASURER
COCOA

Janet Price
FERNANDINA BEACH

APPENDIX B

IRC Fertilizer Ordinances

ORDINANCE NO. 2013 - 012

AN ORDINANCE OF THE BOARD OF COUNTY COMMISSIONERS OF INDIAN RIVER COUNTY, FLORIDA, AMENDING THE CODE OF INDIAN RIVER COUNTY TO ESTABLISH A NEW CHAPTER 316, ENTITLED "FERTILIZER AND LANDSCAPE MANAGEMENT;" ADOPTING THE FLORIDA DEPARTMENT OF ENVIRONMENTAL PROTECTION'S MODEL ORDINANCE FOR FLORIDA-FRIENDLY USE OF FERTILIZER ON URBAN LANDSCAPES, WITH MODIFICATIONS; MAKING FINDINGS AND PROVIDING FOR SEVERABILITY, CODIFICATION; DIRECTING COUNTY ATTORNEY'S OFFICE TO POST SUMMARY ON COUNTY WEBSITE, AND AN EFFECTIVE DATE.

WHEREAS, as a result of impairment to Indian River County's surface waters caused by excessive nutrients, or, as a result of increasing levels of nitrogen in the surface and/or ground water within the aquifers or canals within the boundaries of Indian River County, the Board of County Commissioners has determined that the use of fertilizers on lands within Indian River County creates a risk of contributing to adverse effects on surface and/or ground water; and

WHEREAS, in order to address this risk, the Board of County Commissioners has determined that it is not only critical to adopt the Florida Department of Environmental Protection's Model Ordinance for Florida-Friendly Use of Fertilizer on Urban Landscapes, but that as part of Indian River County's science-based, and economically and technically feasible, comprehensive program to address nonpoint sources of nutrient pollution, additional and more stringent standards are necessary in order to adequately address urban fertilizer contributions to nonpoint source nutrient loading to the surface and/or ground water of Indian River County; and

WHEREAS, this ordinance regulates the proper use of fertilizers by any applicator; requires proper training of Commercial Fertilizer Applicators and Institutional Fertilizer Applicators; establishes training and licensing requirements; establishes a Prohibited Application Period; and specifies allowable fertilizer application rates and methods, fertilizer-free zones, low maintenance zones, and exemptions. The ordinance requires the use of Best Management Practices which provide specific management guidelines to minimize negative secondary and cumulative environmental effects associated with the misuse of fertilizers. These secondary and cumulative effects have been observed in and on Indian River County's natural and constructed stormwater conveyances, rivers, creeks, canals, lakes, estuaries and other water bodies. Collectively, these water bodies are an asset critical to the environmental, recreational, cultural and economic well-being of Indian River County residents and the health of the public. Overgrowth of algae and vegetation hinder the effectiveness of flood attenuation provided by natural and constructed stormwater conveyances. Regulation of nutrients, including both phosphorus and nitrogen contained in fertilizer, will help improve and maintain water and habitat quality,

ORDINANCE NO. 2013 - 012

NOW, THEREFORE, BE IT ORDAINED BY THE BOARD OF COUNTY COMMISSIONERS OF INDIAN RIVER COUNTY, FLORIDA, THAT:

Section 1. Enactment Authority.

Article VIII, §1 of the Florida Constitution and Chapter 125, Florida Statutes vest broad home rule powers in counties to enact ordinances, not inconsistent with general or special law, for the purpose of promoting the public health, safety and welfare of the residents of the county. The Board specifically determines that the enactment of this ordinance is consistent with general or special law, and is necessary and appropriate to promote the health, safety and welfare of the residents of Indian River County.

Section 2. Findings.

The Board finds that the above "Whereas" clauses are true and correct, and hereby incorporates such clauses as findings of the Board.

Section 3. Adoption of Chapter 316 of the Code of Indian River County (the "Code").

Chapter 316 of the Code is hereby adopted, as follows (new language is indicated by underline):

Section 316.1. Title.

This chapter shall be known as the "Indian River County Fertilizer and Landscape Management Ordinance."

Section 316.2. Definitions.

For the purposes of this chapter, the following terms shall have the following meanings:

"Administrator" shall mean the County Administrator, or an administrative official of the County designated by the County Administrator to administer and enforce the provisions of this chapter.

"Application" or "apply" shall mean the actual physical deposit of fertilizer to turf or landscape plants.

"Applicator" shall mean any Person who applies fertilizer on turf and/or landscape plants in Indian River County.

"Board" shall mean the Indian River County Board of County Commissioners.

"Best Management Practices" shall mean turf and landscape practices or combination of practices based on research, field-testing, and expert review, determined to be the most effective

ORDINANCE NO. 2013 - _____

and practicable on-location means, including economic and technological considerations, for improving water quality, conserving water supplies and protecting natural resources.

“Chapter 85-427” shall mean The Indian River County Environmental Control Act, Chapter 85-427, Special Acts, Laws of Florida.

“Code Enforcement Officer shall mean any designated employee or agent of Indian River County whose duty it is to enforce codes and ordinances enacted by Indian River County.

“Commercial Fertilizer Applicator,” except as provided in §482.1562(9), Florida Statutes, shall mean any person who applies fertilizer for payment or other consideration to property not owned by the person or firm applying the fertilizer or the employer of the applicator.

“Code” shall mean The Code of Indian River County.

“Environmental Control Officer” shall mean the Indian River County Environmental Control Officer appointed by the Board pursuant to Chapter 85-427, and Chapter 303 (Part I) of this Code, and his or her designees.

“Fertilize,” “fertilizing,” or “fertilization” shall mean the act of applying fertilizer to turf, specialized turf, or landscape plants.

“Fertilizer” shall mean any substance or mixture of substances that contains one or more recognized plant nutrients and promotes plant growth, or controls soil acidity or alkalinity, or provides other soil enrichment, or provides other corrective measures to the soil.

“Heavy rain” shall mean rainfall greater than two inches in a 24 hour period.

“Institutional Fertilizer Applicator” shall mean any person, other than a private, non-commercial applicator or a Commercial Fertilizer Applicator (unless such definitions also apply under the circumstances), that applies fertilizer for the purpose of maintaining turf and/or landscape plants. Institutional Fertilizer Applicators shall include, but shall not be limited to, owners, managers or employees of public lands, schools, parks, religious institutions, utilities, industrial or business sites and any residential properties maintained in condominium and/or common ownership.

“Landscape plant” shall mean any native or exotic tree, shrub, or groundcover (excluding turf).

“Low maintenance zone” shall mean an area a minimum of ten feet wide adjacent to water courses which is planted and managed in order to minimize the need for fertilization, watering, mowing, etc.

“Person” shall mean any natural person, business, corporation, limited liability company, partnership, limited partnership, association, club, organization, and/or any group of people acting as an organized entity.

ORDINANCE NO. 2013 - 012

"Restricted Season" shall mean June 1 through September 30.

"Saturated soil" shall mean a soil in which the voids are filled with water. Saturation does not require flow. For the purposes of this chapter, soils shall be considered saturated if standing water is present or the pressure of a person standing on the soil causes the release of free water.

"Slow Release Nitrogen" shall mean nitrogen in a form which delays its availability for plant uptake and use after application, or which extends its availability to the plant longer than a reference rapid or quick release product.

"Turf," "sod," or "lawn" shall mean a piece of grass-covered soil held together by the roots of the grass.

"Urban landscape" shall mean pervious areas on residential, commercial, industrial, institutional, highway rights-of-way, or other nonagricultural lands that are planted with turf or horticultural plants. For the purposes of this section, agriculture has the same meaning as in §570.02, Florida Statutes.

Section 316.3. Timing of fertilizer application.

No applicator shall apply fertilizers containing nitrogen and/or phosphorus to turf and/or landscape plants during the Restricted Season, to saturated soils, or during a period in which a Flood Watch or Warning, or a Tropical Storm Watch or Warning, or a Hurricane Watch or Warning is in effect for any portion of Indian River County, issued by the National Weather Service, or if heavy rain is likely.

Section 316.4. Fertilizer-free zones.

Fertilizer shall not be applied within ten feet of any pond, stream, watercourse, lake, canal, or wetland as defined by the Florida Department of Environmental Protection (Chapter 62-340, Florida Administrative Code) or from the top of a seawall. If more stringent Indian River County Code regulations apply, this provision does not relieve the requirement to adhere to the more stringent regulations. Newly planted turf and/or landscape plants may be fertilized in this zone only for a 60-day period beginning thirty days after planting if needed to allow the plants to become well established. Caution shall be used to prevent nutrients from being directly deposited into the water.

Section 316.5. Low maintenance zones.

A voluntary ten foot low maintenance zone is strongly recommended, but not mandated, from any pond, stream, water course, lake, wetland or from the top of a seawall. A swale/berm system is recommended for installation at the landward edge of this low maintenance zone to capture and filter runoff. If more stringent Indian River County Code regulations apply, this provision

ORDINANCE NO. 2013 - 012

does not relieve the requirement to adhere to the more stringent regulations. Notwithstanding the voluntary nature of the above sentences, no mowed or cut vegetative material may be deposited or left remaining in this zone or deposited in the water. Care should be taken to prevent the overspray of aquatic weed products in this zone.

Section 316.6. Fertilizer content and application rates.

(a) No fertilizer containing phosphorous shall be applied to turf or landscape plants in Indian River County unless a soil or plant tissue deficiency is verified by a University of Florida, Institute of Food and Agriculture Sciences, approved testing methodology. In the case that a deficiency has been verified, the application of a fertilizer containing phosphorous shall be in accordance with the rates and directions for the Central Region of Florida as provided by Rule 5E-1.003(2), Florida Administrative Code. Deficiency verification shall be no more than 2 years old. However, recent application of compost, manure, or top soil shall warrant more recent testing to verify current deficiencies.

(b) The nitrogen content of fertilizer applied to turf or landscape plants within Indian River County shall contain at least 50% slow release nitrogen per guaranteed analysis label.

(c) Fertilizers applied to an urban lawn or turf within Indian River County shall be applied in accordance with requirements and directions set forth on the label or tag for packaged fertilizer products, or in the printed information accompanying the delivery of bulk fertilizer products, as provided by Rule 5E-1.003(2), Florida Administrative Code, *Labeling Requirements For Urban Turf Fertilizers*. All packaged and bulk fertilizer products sold in Indian River County shall be sold in packages with labels or tags, or, if sold in bulk, be accompanied by printed information, which complies with the requirements of Rule 5E-1.003(2), Florida Administrative Code.

(d) Fertilizer containing nitrogen or phosphorus shall not be applied before seeding or sodding a site, and shall not be applied for the first 30 days after seeding or sodding, except when hydro-seeding for temporary or permanent erosion control in an emergency situation (wildfire, etc.), or in accordance with the Stormwater Pollution Prevention Plan for that site.

Section 316.7. Application practices.

(a) Spreader deflector shields are required when fertilizing via rotary (broadcast) spreaders. Deflectors must be positioned such that fertilizer granules are deflected away from all impervious surfaces, fertilizer-free zones and water bodies, including wetlands.

(b) Fertilizer shall not be applied, spilled, or otherwise deposited on any impervious surfaces.

(c) Any fertilizer applied, spilled, or deposited, either intentionally or accidentally, on any impervious surface shall be immediately and completely removed to the greatest extent practicable.

ORDINANCE NO. 2013 - 012

(d) Fertilizer released on an impervious surface must be immediately contained and either legally applied to turf or any other legal site, or returned to the original or other appropriate container.

(e) In no case shall fertilizer be washed, swept, or blown off impervious surfaces into stormwater drains, ditches, conveyances, or water bodies.

Section 316.8. Management of grass clippings and vegetative materials.

In no case shall grass clippings, vegetative material, and/or vegetative debris be washed, swept, or blown off into stormwater drains, ditches, conveyances, water bodies, wetlands, or sidewalks or roadways. Any material that is accidentally so deposited shall be immediately removed to the maximum extent practicable.

Section 316.9. Exemptions.

The provisions set forth above in this chapter shall not apply to:

(a) bona fide farm operations as defined in the Florida Right to Farm Act, § 823.14, Florida Statutes;

(b) other properties not subject to or covered under the Florida Right to Farm Act that have pastures used for grazing livestock;

(c) any lands used for bona fide scientific research, including, but not limited to, research on the effects of fertilizer use on urban stormwater, water quality, agronomics, or horticulture.;

(d) golf courses when landscaping is performed within the provisions of the Florida Department of Environmental Protection document, "Best Management Practices for the Enhancement of Environmental Quality on Florida Golf Courses", these provisions shall be followed when applying fertilizer to golf course practice and play areas;

(e) athletic fields at public parks and school facilities that apply the concepts and principles embodied in the Florida Green BMPs, while maintaining the health and function of their specialized turf areas;

(f) vegetable gardens owned by individual property owners or a community, and trees grown for their edible fruit.

Section 316.10. Training.

(a) Within the time period set forth in section 316.12 of this Chapter, all Commercial Fertilizer Applicators and Institutional Fertilizer Applicators within Indian River County shall abide by and successfully complete the six-hour training program in the "Florida-friendly Best

ORDINANCE NO. 2013 - _____

Management Practices for Protection of Water Resources by the Green Industries” offered by the Florida Department of Environmental Protection through the University of Florida Extension “Florida-Friendly Landscapes” program, or an approved equivalent.

(b) Private, non-commercial applicators are encouraged to follow the recommendations of the University of Florida Institute of Food and Agriculture Sciences Florida Yards and Neighborhoods program when applying fertilizers.

Section 316.11. General education program.

The Public Works Department shall have an employee who shall address issues pertaining to this Chapter. This employee shall implement a program to inform the general public of the requirements of this chapter, which program shall include, among other things, informative postings on the County website, printing and distributing informative brochures and other print materials, and speaking engagements at community associations, civic organizations, etc. The program shall also include, to the extent practicable, use of any materials from the Be Floridian program and coordination and collaboration with University of Florida Institute of Food and Agriculture Sciences educational activities. Any claimed or alleged deficiency in the County’s general education program shall not constitute a defense to any action brought to enforce the provisions of this chapter.

Section 316.12. Licensing of commercial fertilizer applicators.

(a) No later than December 31, 2013, all Commercial Fertilizer Applicators within Indian River County, shall abide by and successfully complete training and continuing education requirements in the “Florida-friendly Best Management Practices for Protection of Water Resources by the Green Industries,” offered by the Florida Department of Environmental Protection through the University of Florida Institute of Food and Agriculture Sciences “Florida-friendly Landscapes” program, or an approved equivalent program, prior to obtaining an Indian River County Local Business Tax Certificate for any category of occupation which may apply any fertilizer to turf and/or landscape plants. Commercial Fertilizer Applicators shall provide proof of completion of the program to the Indian River County Tax Collector’s Office within 180 days of the effective date of this ordinance.

(b) After December 31, 2013, all Commercial Fertilizer Applicators within Indian River County shall have and carry in their possession at all times when applying fertilizer, evidence of certification by the Florida Department of Agriculture and Consumer Services as a Commercial Fertilizer Applicator per Rule 5E-14.117(18), Florida Administrative Code.

(c) All businesses applying fertilizer to turf and/or landscape plants (including but not limited to residential lawns, golf courses, commercial properties, and multi-family and condominium properties) must ensure that at least one employee has a “Florida-friendly Best Management Practices for Protection of Water Resources by the Green Industries” training certificate prior to the business owner obtaining a Local Business Tax Certificate. Owners for any category of

ORDINANCE NO. 2013 - 012

occupation which may apply any fertilizer to turf and/or landscape plants shall provide proof of completion of the program to the Indian River County Tax Collector's Office.

Section 316.13. Enforcement.

This chapter may be enforced by the Code Enforcement Officer in the Public Works Department who is devoted to issues pertaining to this Chapter, pursuant to Chapter 162, Florida Statutes, and §103.07 of this Code. In addition, this chapter may be enforced by the Environmental Control Officer pursuant to Chapter 85-427, Special Acts, Laws of Florida, and §303.14 of this Code. Penalties and remedies for violations shall be as set forth in §100.05 of this Code, and, to the extent applicable, Chapter 85-427, Special Acts, Laws of Florida. Funds generated by penalties imposed under this section shall be used by Indian River County for the administration and enforcement of §403.9337, Florida Statutes, and the corresponding sections of this chapter, and to further water conservation and nonpoint pollution prevention activities.

Section 316.14. References to state law.

Any references in this chapter to Florida Statutes, rules or regulations shall refer to such statutes, rules or regulations, as amended from time to time.

Section 316.15. Applicability.

This chapter shall be applicable to and shall regulate any and all applicators of fertilizer and areas of application of fertilizer within the area of Indian River County, unless such applicator is specifically exempted; provided, however, that this chapter shall not apply within the limits of any municipality which has adopted an ordinance regulating the same subject matter. This chapter shall be prospective only, and shall not impair any existing contracts.

Section 4. Severability.

If any part of this ordinance is held to be invalid or unconstitutional by a court of competent jurisdiction, the remainder of this ordinance shall not be affected by such holding and shall remain in full force and effect.

Section 5. Codification.

It is the intention of the Board of County Commissioners that the provisions of this ordinance shall become and be made part of the Indian River County Code, and that the sections of this ordinance may be renumbered or re-lettered and the word ordinance may be changed to section, article or such other appropriate word or phrase in order to accomplish such intention.

ORDINANCE NO. 2013 - 012

Section 6. Directing County Attorney's Office to Post Summary on County Website.

The County Attorney's Office is directed to post a summary of this ordinance on the County's website within 15 days of the filing of this ordinance with the Florida Department of State.

Section 7. Effective Date.

This ordinance shall become effective 45 days after the filing of the ordinance with the Florida Department of State.

This ordinance was advertised in the Vero Beach Press Journal, on the 8th day of July, 2013, for a public hearing to be held on the 18th day of July, 2013, and on the 10th day of August, 2013 for an additional public hearing to be held on the 20th day of August, 2013, at which time it was moved for adoption by Commissioner Solari, seconded by Commissioner O'Bryan, and adopted by the following vote:

Chairman Joseph E. Flescher	<u>AYE</u>
Vice Chairman Wesley S. Davis	<u>AYE</u>
Commissioner Peter D. O'Bryan	<u>AYE</u>
Commissioner Bob Solari	<u>AYE</u>
Commissioner Tim Zorc	<u>AYE</u>

The Chairman thereupon declared the ordinance duly passed and adopted this 20th day of August, 2013.



**BOARD OF COUNTY COMMISSIONERS
INDIAN RIVER COUNTY, FLORIDA**

By: Joseph E. Flescher
Joseph E. Flescher, Chairman

ATTEST: Jeffrey R. Smith, Clerk of Court
and Comptroller

Approved as to form and legal sufficiency:

By: Jeffrey R. Smith
Deputy Clerk

Dylan Reingold
Dylan Reingold, County Attorney

EFFECTIVE DATE: This ordinance was filed with the Florida Department of State on the _____ day of _____, 2013.

ORDINANCE NO. 2013 - 014

AN ORDINANCE OF THE BOARD OF COUNTY COMMISSIONERS OF INDIAN RIVER COUNTY, FLORIDA CONCERNING THE FERTILIZER AND LANDSCAPE MANAGEMENT ORDINANCE, AMENDING SECTION 316.6 (FERTILIZER CONTENT AND APPLICATION RATES) AND SECTION 316.15 (APPLICABILITY) OF CHAPTER 316 (INDIAN RIVER COUNTY FERTILIZER AND LANDSCAPE MANAGEMENT ORDINANCE) OF THE CODE OF INDIAN RIVER COUNTY TO ALLOW FOR THE GRADUAL AMORTIZATION OF THE SUPPLY OF CERTAIN NITROGEN CONTAINING FERTILIZER AND APPLYING CHAPTER 316 TO UNINCORPORATED INDIAN RIVER COUNTY, AND MAKING FINDINGS AND PROVIDING FOR SEVERABILITY, CODIFICATION; AND AN EFFECTIVE DATE.

WHEREAS, the Board of County Commissioners adopted an ordinance regulating the proper use of fertilizers in order to protect the water quality of Indian River County's natural and constructed stormwater conveyances, rivers, creeks, canals, lakes, estuaries and other water bodies; and

WHEREAS, the new fertilizer regulations require that the nitrogen content of fertilizer applied to turf or landscape plants within Indian River County shall contain at least 50% slow release nitrogen per guaranteed analysis label; and

WHEREAS, the new fertilizer regulations go into effect on October 14, 2013; and

WHEREAS, in order to provide adequate time for the supply of fertilizer containing nitrogen that does not comply with these regulations to be eliminated, it is necessary to provide additional time for retailers to eliminate those supplies that meet at least a minimum threshold of slow release nitrogen,

NOW, THEREFORE, BE IT ORDAINED BY THE BOARD OF COUNTY COMMISSIONERS OF INDIAN RIVER COUNTY, FLORIDA, THAT:

Section 1. Enactment Authority.

Article VIII, §1 of the Florida Constitution and Chapter 125, Florida Statutes vest broad home rule powers in counties to enact ordinances, not inconsistent with general or special law, for the purpose of promoting the public health, safety and welfare of the residents of the county. The Board specifically determines that the enactment of this ordinance is consistent with general or special law, and is necessary and appropriate to promote the health, safety and welfare of the residents of Indian River County.

Section 2. Findings.

The Board finds that the above "Whereas" clauses are true and correct, and hereby incorporates such clauses as findings of the Board.

ORDINANCE NO. 2013 - 014

Section 3. Amendment of Section 316.6 (Fertilizer content and application rates) of Chapter 316 (Indian River County Fertilizer and Landscape Management Ordinance) of the Code of Indian River County (the "Code").

Section 316.6 (Fertilizer content and application rates) of Chapter 316 (Indian River County Fertilizer and Landscape Management Ordinance) of the Code is hereby amended as follows:

Section 316.6. Fertilizer content and application rates.

(b) As of the effective date of this chapter, the The nitrogen content of fertilizer applied to turf or landscape plants within Indian River County shall contain at least ~~25~~50% slow release nitrogen per guaranteed analysis label. As of June 1, 2014, the nitrogen content of fertilizer applied to turf or landscape plants within Indian River County shall contain at least 50% slow release nitrogen per guaranteed analysis label.

Section 4. Amendment of Section 316.15 (Applicability) of Chapter 316 (Indian River County Fertilizer and Landscape Management Ordinance) of the Code of Indian River County (the "Code").

Section 316.15 (Applicability) of Chapter 316 (Indian River County Fertilizer and Landscape Management Ordinance) of the Code is hereby amended as follows:

Section 316.15. Applicability.

This chapter shall be applicable to and shall regulate any and all applicators of fertilizer and areas of application of fertilizer within the unincorporated area of Indian River County, unless such applicator is specifically exempted; ~~provided, however, that this chapter shall not apply within the limits of any municipality which has adopted an ordinance regulating the same subject matter.~~ This chapter shall be prospective only, and shall not impair any existing contracts.

Section 5. Severability.

If any part of this ordinance is held to be invalid or unconstitutional by a court of competent jurisdiction, the remainder of this ordinance shall not be affected by such holding and shall remain in full force and effect.

Section 6. Codification.

It is the intention of the Board of County Commissioners that the provisions of this ordinance shall become and be made part of the Indian River County Code, and that the sections of this ordinance may be renumbered or re-lettered and the word ordinance may be changed to section, article or such other appropriate word or phrase in order to accomplish such intention.

ORDINANCE NO. 2013 - 014

Section 7. Effective Date.

This ordinance shall become effective upon filing with the Florida Department of State.

This ordinance was advertised in the Vero Beach Press Journal, on the 16th day of September, 2013, for a public hearing to be held on the 1st day of October, 2013, at which time it was moved for adoption by Commissioner Solari, seconded by Commissioner O'Bryan, and adopted by the following vote:

Chairman Joseph E. Flescher	<u>Aye</u>
Vice Chairman Wesley S. Davis	<u>Aye</u>
Commissioner Peter D. O'Bryan	<u>Aye</u>
Commissioner Bob Solari	<u>Aye</u>
Commissioner Tim Zorc	<u>Aye</u>

The Chairman thereupon declared the ordinance duly passed and adopted this 1st day of October, 2013.



**BOARD OF COUNTY COMMISSIONERS
INDIAN RIVER COUNTY, FLORIDA**

By: Joseph E. Flescher
Joseph E. Flescher, Chairman

ATTEST: Jeffrey R. Smith, Clerk of Court
and Comptroller

Approved as to form and legal sufficiency:

By: Laura Allen
Deputy Clerk

Dylan Reingold
Dylan Reingold, County Attorney

EFFECTIVE DATE: This ordinance was filed with the Florida Department of State on the ____ day of _____, 2013.

APPENDIX C

IRC Traffic Engineering Special Conditions for Right-of-Way Construction



INDIAN RIVER COUNTY TRAFFIC ENGINEERING DIVISION SPECIAL CONDITIONS FOR RIGHT-OF-WAY CONSTRUCTION

SPECIAL CONDITIONS:

1. All work performed under this permit shall be in accordance with the Florida Department of Transportation Design Standards (<https://www.fdot.gov/design/standardplans/current/default.shtm>), Indices 102-600 and the Manual on Uniform Traffic Control Devices.
2. All special conditions listed are in addition to the attached Indian River County Traffic Engineering Regulations for Maintenance of Traffic.
3. It shall be the contractor's responsibility to contact Sunshine State One Call System (1-800-432-4770) at least 72 hours in advance of commencing construction work to coordinate traffic control and obtain locations of underground traffic signal conduit for the County's Computerized Traffic Signal Coordination System.
4. The contractor shall be responsible for using the applicable Traffic Control Plan for the type of work being performed. All job supervisors shall have a copy of the control plan on site at all times and shall be familiar with the correct set-up of the plan.
5. At least one lane of traffic shall be maintained at all times. One-lane traffic shall be controlled with at least two (2) flagmen. Flagmen shall use STOP/SLOW paddles at all times. Flags shall not be used for one-lane traffic control.
6. **After proper notification to Traffic Engineering**, consideration will be given to the contractor to close roadways to through traffic on a daily basis during daylight hours on narrow roadways where maintaining one-lane traffic would be difficult. The roadway shall be open to traffic at the end of each work day and on weekends. It shall be the contractor's responsibility to provide all necessary construction signs and traffic control devices to close the road and provide a detour route in accordance with Indian River County standards. Signing shall be installed that clearly indicates the time periods the road is closed to traffic.
7. There shall be no construction work after dark.
8. All open excavations shall be back filled before the close of each work day.
9. A compacted roadway shall be provided at the end of each work day. Disrupted roadways shall be clearly marked as a construction area.
10. Refer to the attached Traffic Engineering Regulations for construction work on Indian River County roadways for maintenance of traffic inspection policy and procedure
11. All construction equipment, materials, etc. shall be stored outside of the clear zone. Equipment and construction materials that are stored within the clear zone shall be clearly marked with Type II barricades with flashing yellow lights.
12. All projects and work within Indian River County right-of-way shall have an approved Traffic Control Plan (TCP). All work shall be executed under the established TCP and Indian River County approved procedures. The TCP shall provide the proposed detour route, traffic control devices, and other pertinent information for the proposed project and shall be submitted for review and approval by the Public Works Department.
The TCP shall be prepared by personnel with a minimum of an Intermediate Maintenance of Traffic current certification in the State of Florida. (Denote on the TCP, certification number and name of the certified personnel that prepared the MOT plan.)
For full road closures, a TCP is required to be submitted by the contractor a minimum of two (2) weeks prior to the proposed road closure.

All traffic control devices shall be in accordance with the Florida Department of Transportation (FDOT) Design Standards, Indices 102-600, FY 2019-2020, and the Manual on Uniform Traffic Control Devices, 2009 Edition.
13. For full road closures, Portable Changeable Message Signs are required to pre-advertise the roadway closure, a minimum of seven (7) days in advance of the road closure and during the duration of the road closure. The use of Portable Changeable Message Signs for lane closures on thoroughfare plan roadways will be required. Messages are to be approved by the Public Works Department and shown on the TCP.

TRAFFIC ENGINEERING REGULATIONS

Maintenance and Protection of Traffic:

It shall be the responsibility of the contractor to provide for the maintenance and protection of traffic in accordance with the applicable indices in the most current edition of the Florida Department of Transportation Roadway and Traffic Design Standards and the Federal Highway Administration Manual on Uniform Traffic Control Devices. The indices shall be considered the minimum standards and a

Special Conditions for Right of Way Construction

Page 2

more extensive work zone set-up or modifications may be required by the County Public Work Director or his designee for the protection of personnel in the work area as well as the traveling public.

It shall be the responsibility of the contractor to ensure that all subcontractors are in full compliance with all traffic control regulations. It shall be the responsibility of the contractor working on County roadways or within Right-of-Ways to establish maintenance of traffic prior to any work being performed. The contractor shall frequently monitor the work zone set-up to ensure that all signing is properly placed and that warning signs remain at the proper advance posting distance from the work area. Any signs that do not apply to the work zone shall be removed or covered. The contractor shall remove the work zone set-up at the conclusion of the work.

Traffic Engineering shall be notified a minimum of seventy-two (72) hours in advance of any lane closings and ten (10) days in advance of any road closures.

Lane closures are restricted to outside the normal peak hours of traffic, lane closures shall occur during the hours of 9:00 AM to 4:00 PM unless otherwise approved by the Public Works Director or his designee.

Traffic Engineering staff shall inspect the Maintenance of Traffic prior to construction commencement to ensure compliance with the approved Traffic Control Plan.

It is the policy of the Traffic Engineering Division to randomly monitor the contractor's compliance with all regulations while working on County roadways and within right-of-ways. Matters of public safety shall be attended to immediately upon notification by the County Public Work Director or his designee.

If the contractor is found to be negligent in maintaining proper work zone set-up in accordance with the County's Right-of-Way ordinance (Chapter 312), the County Public Work Director or his designee shall impose penalties in the amount of \$250.00 for working without the proper traffic control.

Construction at or Near Signalized Intersections:

The contractor shall have full responsibility for any work performed at or near any traffic signals in Indian River County. The contractor shall request that the County locate buried interconnect conduit and cable, loop sensors, and pull boxes prior to commencing construction. Any damage to the interconnect conduit, loop sensors, and pull boxes or any other traffic signal equipment shall be repaired at the contractor's expense. It shall be the responsibility of the contractor to notify Traffic Engineering Division a minimum of 72 hours prior to any work being performed near a signalized intersection or flashing beacon.

Once the proper notification and locate procedures are satisfied, the contractor working in or near signalized intersections or around traffic signal poles, signal cabinets, or flashing beacons shall be advised of the following regulations:

1. No excavation shall be performed within a 15-foot radius of any traffic signal pole. If excavation is necessary within a 15-foot radius, it will be the contractor's responsibility to provide the following:
 - a. In a manner approved by the County Public Works Director or his designee, the contractor shall provide constant support of the traffic signal pole to prevent movement during excavation and backfill operations.
 - b. Compaction around the excavation site to a 98% density, bringing the backfill up in 1 foot lifts.
 - c. Density reports from a licensed testing company provided to the County Public Works Director.
 - d. Restore the traffic signal and all support equipment to original condition or better.
2. There shall be no pavement cuts made within 500 feet of a signal or flashing beacon without contacting Indian River County Traffic Engineering Division at (772-226-1547), 72 hours prior to construction.
3. Any traffic signal, loop sensors, conduit, interconnect cable, or any support equipment damaged by a contractor shall be repaired/replaced at the contractor's expense.
4. Any contractor that works at or in the vicinity of a signalized intersection shall have full responsibility for any liability incurred by causing damage to signal equipment that results in the failure of the traffic signal functions. If such a failure occurs, the contractor shall notify the police and the Traffic Engineering Division immediately at (772-226-1547).

APPENDIX D

FHWA-1273 FEDERAL REQUIRED CONTRACT PROVISIONS

**REQUIRED CONTRACT PROVISIONS
FEDERAL-AID CONSTRUCTION CONTRACTS**

- I. General
- II. Nondiscrimination
- III. Non-segregated Facilities
- IV. Davis-Bacon and Related Act Provisions
- V. Contract Work Hours and Safety Standards Act Provisions
- VI. Subletting or Assigning the Contract
- VII. Safety: Accident Prevention
- VIII. False Statements Concerning Highway Projects
- IX. Implementation of Clean Air Act and Federal Water Pollution Control Act
- X. Certification Regarding Debarment, Suspension, Ineligibility and Voluntary Exclusion
- XI. Certification Regarding Use of Contract Funds for Lobbying
- XII. Use of United States-Flag Vessels:

ATTACHMENTS

A. Employment and Materials Preference for Appalachian Development Highway System or Appalachian Local Access Road Contracts (included in Appalachian contracts only)

I. GENERAL

1. Form FHWA-1273 must be physically incorporated in each construction contract funded under title 23, United States Code, as required in 23 CFR 633.102(b) (excluding emergency contracts solely intended for debris removal). The contractor (or subcontractor) must insert this form in each subcontract and further require its inclusion in all lower tier subcontracts (excluding purchase orders, rental agreements and other agreements for supplies or services). 23 CFR 633.102(e).

The applicable requirements of Form FHWA-1273 are incorporated by reference for work done under any purchase order, rental agreement or agreement for other services. The prime contractor shall be responsible for compliance by any subcontractor, lower-tier subcontractor or service provider. 23 CFR 633.102(e).

Form FHWA-1273 must be included in all Federal-aid design-build contracts, in all subcontracts and in lower tier subcontracts (excluding subcontracts for design services, purchase orders, rental agreements and other agreements for supplies or services) in accordance with 23 CFR 633.102. The design-builder shall be responsible for compliance by any subcontractor, lower-tier subcontractor or service provider.

Contracting agencies may reference Form FHWA-1273 in solicitation-for-bids or request-for-proposals documents, however, the Form FHWA-1273 must be physically incorporated (not referenced) in all contracts, subcontracts and lower-tier subcontracts (excluding purchase orders, rental agreements and other agreements for supplies or services related to a construction contract). 23 CFR 633.102(b).

2. Subject to the applicability criteria noted in the following sections, these contract provisions shall apply to all work

performed on the contract by the contractor's own organization and with the assistance of workers under the contractor's immediate superintendence and to all work performed on the contract by piecework, station work, or by subcontract. 23 CFR 633.102(d).

3. A breach of any of the stipulations contained in these Required Contract Provisions may be sufficient grounds for withholding of progress payments, withholding of final payment, termination of the contract, suspension / debarment or any other action determined to be appropriate by the contracting agency and FHWA.

4. Selection of Labor: During the performance of this contract, the contractor shall not use convict labor for any purpose within the limits of a construction project on a Federal-aid highway unless it is labor performed by convicts who are on parole, supervised release, or probation. 23 U.S.C. 114(b). The term Federal-aid highway does not include roadways functionally classified as local roads or rural minor collectors. 23 U.S.C. 101(a).

II. NONDISCRIMINATION (23 CFR 230.107(a); 23 CFR Part 230, Subpart A, Appendix A; EO 11246)

The provisions of this section related to 23 CFR Part 230, Subpart A, Appendix A are applicable to all Federal-aid construction contracts and to all related construction subcontracts of \$10,000 or more. The provisions of 23 CFR Part 230 are not applicable to material supply, engineering, or architectural service contracts.

In addition, the contractor and all subcontractors must comply with the following policies: Executive Order 11246, 41 CFR Part 60, 29 CFR Parts 1625-1627, 23 U.S.C. 140, Section 504 of the Rehabilitation Act of 1973, as amended (29 U.S.C. 794), Title VI of the Civil Rights Act of 1964, as amended (42 U.S.C. 2000d et seq.), and related regulations including 49 CFR Parts 21, 26, and 27; and 23 CFR Parts 200, 230, and 633.

The contractor and all subcontractors must comply with: the requirements of the Equal Opportunity Clause in 41 CFR 60-1.4(b) and, for all construction contracts exceeding \$10,000, the Standard Federal Equal Employment Opportunity Construction Contract Specifications in 41 CFR 60-4.3.

Note: The U.S. Department of Labor has exclusive authority to determine compliance with Executive Order 11246 and the policies of the Secretary of Labor including 41 CFR Part 60, and 29 CFR Parts 1625-1627. The contracting agency and the FHWA have the authority and the responsibility to ensure compliance with 23 U.S.C. 140, Section 504 of the Rehabilitation Act of 1973, as amended (29 U.S.C. 794), and Title VI of the Civil Rights Act of 1964, as amended (42 U.S.C. 2000d et seq.), and related regulations including 49 CFR Parts 21, 26, and 27; and 23 CFR Parts 200, 230, and 633.

The following provision is adopted from 23 CFR Part 230, Subpart A, Appendix A, with appropriate revisions to conform to the U.S. Department of Labor (US DOL) and FHWA requirements.

1. Equal Employment Opportunity: Equal Employment Opportunity (EEO) requirements not to discriminate and to take affirmative action to assure equal opportunity as set forth under laws, executive orders, rules, regulations (see 28 CFR Part 35, 29 CFR Part 1630, 29 CFR Parts 1625-1627, 41 CFR Part 60 and 49 CFR Part 27) and orders of the Secretary of Labor as modified by the provisions prescribed herein, and imposed pursuant to 23 U.S.C. 140, shall constitute the EEO and specific affirmative action standards for the contractor's project activities under this contract. The provisions of the Americans with Disabilities Act of 1990 (42 U.S.C. 12101 et seq.) set forth under 28 CFR Part 35 and 29 CFR Part 1630 are incorporated by reference in this contract. In the execution of this contract, the contractor agrees to comply with the following minimum specific requirement activities of EEO:

a. The contractor will work with the contracting agency and the Federal Government to ensure that it has made every good faith effort to provide equal opportunity with respect to all of its terms and conditions of employment and in their review of activities under the contract. 23 CFR 230.409 (g)(4) & (5).

b. The contractor will accept as its operating policy the following statement:

"It is the policy of this Company to assure that applicants are employed, and that employees are treated during employment, without regard to their race, religion, sex, sexual orientation, gender identity, color, national origin, age or disability. Such action shall include: employment, upgrading, demotion, or transfer; recruitment or recruitment advertising; layoff or termination; rates of pay or other forms of compensation; and selection for training, including apprenticeship, pre-apprenticeship, and/or on-the-job training."

2. EEO Officer: The contractor will designate and make known to the contracting officers an EEO Officer who will have the responsibility for and must be capable of effectively administering and promoting an active EEO program and who must be assigned adequate authority and responsibility to do so.

3. Dissemination of Policy: All members of the contractor's staff who are authorized to hire, supervise, promote, and discharge employees, or who recommend such action or are substantially involved in such action, will be made fully cognizant of and will implement the contractor's EEO policy and contractual responsibilities to provide EEO in each grade and classification of employment. To ensure that the above agreement will be met, the following actions will be taken as a minimum:

a. Periodic meetings of supervisory and personnel office employees will be conducted before the start of work and then not less often than once every six months, at which time the contractor's EEO policy and its implementation will be reviewed and explained. The meetings will be conducted by the EEO Officer or other knowledgeable company official.

b. All new supervisory or personnel office employees will be given a thorough indoctrination by the EEO Officer, covering all major aspects of the contractor's EEO obligations within thirty days following their reporting for duty with the contractor.

c. All personnel who are engaged in direct recruitment for the project will be instructed by the EEO Officer in the contractor's procedures for locating and hiring minorities and women.

d. Notices and posters setting forth the contractor's EEO policy will be placed in areas readily accessible to employees, applicants for employment and potential employees.

e. The contractor's EEO policy and the procedures to implement such policy will be brought to the attention of employees by means of meetings, employee handbooks, or other appropriate means.

4. Recruitment: When advertising for employees, the contractor will include in all advertisements for employees the notation: "An Equal Opportunity Employer." All such advertisements will be placed in publications having a large circulation among minorities and women in the area from which the project work force would normally be derived.

a. The contractor will, unless precluded by a valid bargaining agreement, conduct systematic and direct recruitment through public and private employee referral sources likely to yield qualified minorities and women. To meet this requirement, the contractor will identify sources of potential minority group employees and establish with such identified sources procedures whereby minority and women applicants may be referred to the contractor for employment consideration.

b. In the event the contractor has a valid bargaining agreement providing for exclusive hiring hall referrals, the contractor is expected to observe the provisions of that agreement to the extent that the system meets the contractor's compliance with EEO contract provisions. Where implementation of such an agreement has the effect of discriminating against minorities or women, or obligates the contractor to do the same, such implementation violates Federal nondiscrimination provisions.

c. The contractor will encourage its present employees to refer minorities and women as applicants for employment. Information and procedures with regard to referring such applicants will be discussed with employees.

5. Personnel Actions: Wages, working conditions, and employee benefits shall be established and administered, and personnel actions of every type, including hiring, upgrading, promotion, transfer, demotion, layoff, and termination, shall be taken without regard to race, color, religion, sex, sexual orientation, gender identity, national origin, age or disability. The following procedures shall be followed:

a. The contractor will conduct periodic inspections of project sites to ensure that working conditions and employee facilities do not indicate discriminatory treatment of project site personnel.

b. The contractor will periodically evaluate the spread of wages paid within each classification to determine any evidence of discriminatory wage practices.

c. The contractor will periodically review selected personnel actions in depth to determine whether there is evidence of discrimination. Where evidence is found, the contractor will promptly take corrective action. If the review indicates that the discrimination may extend beyond the actions reviewed, such corrective action shall include all affected persons.

d. The contractor will promptly investigate all complaints of alleged discrimination made to the contractor in connection with its obligations under this contract, will attempt to resolve such complaints, and will take appropriate corrective action

within a reasonable time. If the investigation indicates that the discrimination may affect persons other than the complainant, such corrective action shall include such other persons. Upon completion of each investigation, the contractor will inform every complainant of all of their avenues of appeal.

6. Training and Promotion:

a. The contractor will assist in locating, qualifying, and increasing the skills of minorities and women who are applicants for employment or current employees. Such efforts should be aimed at developing full journey level status employees in the type of trade or job classification involved.

b. Consistent with the contractor's work force requirements and as permissible under Federal and State regulations, the contractor shall make full use of training programs (i.e., apprenticeship and on-the-job training programs for the geographical area of contract performance). In the event a special provision for training is provided under this contract, this subparagraph will be superseded as indicated in the special provision. The contracting agency may reserve training positions for persons who receive welfare assistance in accordance with 23 U.S.C. 140(a).

c. The contractor will advise employees and applicants for employment of available training programs and entrance requirements for each.

d. The contractor will periodically review the training and promotion potential of employees who are minorities and women and will encourage eligible employees to apply for such training and promotion.

7. Unions: If the contractor relies in whole or in part upon unions as a source of employees, the contractor will use good faith efforts to obtain the cooperation of such unions to increase opportunities for minorities and women. 23 CFR 230.409. Actions by the contractor, either directly or through a contractor's association acting as agent, will include the procedures set forth below:

a. The contractor will use good faith efforts to develop, in cooperation with the unions, joint training programs aimed toward qualifying more minorities and women for membership in the unions and increasing the skills of minorities and women so that they may qualify for higher paying employment.

b. The contractor will use good faith efforts to incorporate an EEO clause into each union agreement to the end that such union will be contractually bound to refer applicants without regard to their race, color, religion, sex, sexual orientation, gender identity, national origin, age, or disability.

c. The contractor is to obtain information as to the referral practices and policies of the labor union except that to the extent such information is within the exclusive possession of the labor union and such labor union refuses to furnish such information to the contractor, the contractor shall so certify to the contracting agency and shall set forth what efforts have been made to obtain such information.

d. In the event the union is unable to provide the contractor with a reasonable flow of referrals within the time limit set forth in the collective bargaining agreement, the contractor will, through independent recruitment efforts, fill the employment vacancies without regard to race, color, religion, sex, sexual orientation, gender identity, national origin, age, or disability; making full efforts to obtain qualified and/or qualifiable minorities and women. The failure of a union to provide

sufficient referrals (even though it is obligated to provide exclusive referrals under the terms of a collective bargaining agreement) does not relieve the contractor from the requirements of this paragraph. In the event the union referral practice prevents the contractor from meeting the obligations pursuant to Executive Order 11246, as amended, and these special provisions, such contractor shall immediately notify the contracting agency.

8. Reasonable Accommodation for Applicants / Employees with Disabilities: The contractor must be familiar with the requirements for and comply with the Americans with Disabilities Act and all rules and regulations established thereunder. Employers must provide reasonable accommodation in all employment activities unless to do so would cause an undue hardship.

9. Selection of Subcontractors, Procurement of Materials and Leasing of Equipment: The contractor shall not discriminate on the grounds of race, color, religion, sex, sexual orientation, gender identity, national origin, age, or disability in the selection and retention of subcontractors, including procurement of materials and leases of equipment. The contractor shall take all necessary and reasonable steps to ensure nondiscrimination in the administration of this contract.

a. The contractor shall notify all potential subcontractors, suppliers, and lessors of their EEO obligations under this contract.

b. The contractor will use good faith efforts to ensure subcontractor compliance with their EEO obligations.

10. Assurances Required:

a. The requirements of 49 CFR Part 26 and the State DOT's FHWA-approved Disadvantaged Business Enterprise (DBE) program are incorporated by reference.

b. The contractor, subrecipient or subcontractor shall not discriminate on the basis of race, color, national origin, or sex in the performance of this contract. The contractor shall carry out applicable requirements of 49 CFR part 26 in the award and administration of DOT-assisted contracts. Failure by the contractor to carry out these requirements is a material breach of this contract, which may result in the termination of this contract or such other remedy as the recipient deems appropriate, which may include, but is not limited to:

- (1) Withholding monthly progress payments;
- (2) Assessing sanctions;
- (3) Liquidated damages; and/or
- (4) Disqualifying the contractor from future bidding as non-responsible.

c. The Title VI and nondiscrimination provisions of U.S. DOT Order 1050.2A at Appendixes A and E are incorporated by reference. 49 CFR Part 21.

11. Records and Reports: The contractor shall keep such records as necessary to document compliance with the EEO requirements. Such records shall be retained for a period of three years following the date of the final payment to the contractor for all contract work and shall be available at reasonable times and places for inspection by authorized representatives of the contracting agency and the FHWA.

a. The records kept by the contractor shall document the following:

(1) The number and work hours of minority and non-minority group members and women employed in each work classification on the project;

(2) The progress and efforts being made in cooperation with unions, when applicable, to increase employment opportunities for minorities and women; and

(3) The progress and efforts being made in locating, hiring, training, qualifying, and upgrading minorities and women.

b. The contractors and subcontractors will submit an annual report to the contracting agency each July for the duration of the project indicating the number of minority, women, and non-minority group employees currently engaged in each work classification required by the contract work. This information is to be reported on [Form FHWA-1391](#). The staffing data should represent the project work force on board in all or any part of the last payroll period preceding the end of July. If on-the-job training is being required by special provision, the contractor will be required to collect and report training data. The employment data should reflect the work force on board during all or any part of the last payroll period preceding the end of July.

III. NONSEGREGATED FACILITIES

This provision is applicable to all Federal-aid construction contracts and to all related construction subcontracts of more than \$10,000. 41 CFR 60-1.5.

As prescribed by 41 CFR 60-1.8, the contractor must ensure that facilities provided for employees are provided in such a manner that segregation on the basis of race, color, religion, sex, sexual orientation, gender identity, or national origin cannot result. The contractor may neither require such segregated use by written or oral policies nor tolerate such use by employee custom. The contractor's obligation extends further to ensure that its employees are not assigned to perform their services at any location under the contractor's control where the facilities are segregated. The term "facilities" includes waiting rooms, work areas, restaurants and other eating areas, time clocks, restrooms, washrooms, locker rooms and other storage or dressing areas, parking lots, drinking fountains, recreation or entertainment areas, transportation, and housing provided for employees. The contractor shall provide separate or single-user restrooms and necessary dressing or sleeping areas to assure privacy between sexes.

IV. DAVIS-BACON AND RELATED ACT PROVISIONS

This section is applicable to all Federal-aid construction projects exceeding \$2,000 and to all related subcontracts and lower-tier subcontracts (regardless of subcontract size), in accordance with 29 CFR 5.5. The requirements apply to all projects located within the right-of-way of a roadway that is functionally classified as Federal-aid highway. 23 U.S.C. 113. This excludes roadways functionally classified as local roads or rural minor collectors, which are exempt. 23 U.S.C. 101. Where applicable law requires that projects be treated as a project on a Federal-aid highway, the provisions of this subpart will apply regardless of the location of the project. Examples include: Surface Transportation Block Grant Program projects funded under 23 U.S.C. 133 [excluding recreational trails projects], the Nationally Significant Freight and Highway

Projects funded under 23 U.S.C. 117, and National Highway Freight Program projects funded under 23 U.S.C. 167.

The following provisions are from the U.S. Department of Labor regulations in 29 CFR 5.5 "Contract provisions and related matters" with minor revisions to conform to the FHWA-1273 format and FHWA program requirements.

1. Minimum wages (29 CFR 5.5)

a. All laborers and mechanics employed or working upon the site of the work, will be paid unconditionally and not less often than once a week, and without subsequent deduction or rebate on any account (except such payroll deductions as are permitted by regulations issued by the Secretary of Labor under the Copeland Act (29 CFR part 3)), the full amount of wages and bona fide fringe benefits (or cash equivalents thereof) due at time of payment computed at rates not less than those contained in the wage determination of the Secretary of Labor which is attached hereto and made a part hereof, regardless of any contractual relationship which may be alleged to exist between the contractor and such laborers and mechanics.

Contributions made or costs reasonably anticipated for bona fide fringe benefits under section 1(b)(2) of the Davis-Bacon Act on behalf of laborers or mechanics are considered wages paid to such laborers or mechanics, subject to the provisions of paragraph 1.d. of this section; also, regular contributions made or costs incurred for more than a weekly period (but not less often than quarterly) under plans, funds, or programs which cover the particular weekly period, are deemed to be constructively made or incurred during such weekly period. Such laborers and mechanics shall be paid the appropriate wage rate and fringe benefits on the wage determination for the classification of work actually performed, without regard to skill, except as provided in 29 CFR 5.5(a)(4). Laborers or mechanics performing work in more than one classification may be compensated at the rate specified for each classification for the time actually worked therein: Provided, That the employer's payroll records accurately set forth the time spent in each classification in which work is performed. The wage determination (including any additional classification and wage rates conformed under paragraph 1.b. of this section) and the Davis-Bacon poster (WH-1321) shall be posted at all times by the contractor and its subcontractors at the site of the work in a prominent and accessible place where it can be easily seen by the workers.

b.(1) The contracting officer shall require that any class of laborers or mechanics, including helpers, which is not listed in the wage determination and which is to be employed under the contract shall be classified in conformance with the wage determination. The contracting officer shall approve an additional classification and wage rate and fringe benefits therefore only when the following criteria have been met:

(i) The work to be performed by the classification requested is not performed by a classification in the wage determination; and

(ii) The classification is utilized in the area by the construction industry; and

(iii) The proposed wage rate, including any bona fide fringe benefits, bears a reasonable relationship to the wage rates contained in the wage determination.

(2) If the contractor and the laborers and mechanics to be employed in the classification (if known), or their representatives, and the contracting officer agree on the classification and wage rate (including the amount designated for fringe benefits where appropriate), a report of the action taken shall be sent by the contracting officer to the Administrator of the Wage and Hour Division, U.S. Department of Labor, Washington, DC 20210. The Administrator, or an authorized representative, will approve, modify, or disapprove every additional classification action within 30 days of receipt and so advise the contracting officer or will notify the contracting officer within the 30-day period that additional time is necessary.

(3) In the event the contractor, the laborers or mechanics to be employed in the classification or their representatives, and the contracting officer do not agree on the proposed classification and wage rate (including the amount designated for fringe benefits, where appropriate), the contracting officer shall refer the questions, including the views of all interested parties and the recommendation of the contracting officer, to the Administrator for determination. The Administrator, or an authorized representative, will issue a determination within 30 days of receipt and so advise the contracting officer or will notify the contracting officer within the 30-day period that additional time is necessary.

(4) The wage rate (including fringe benefits where appropriate) determined pursuant to paragraphs 1.b.(2) or 1.b.(3) of this section, shall be paid to all workers performing work in the classification under this contract from the first day on which work is performed in the classification.

c. Whenever the minimum wage rate prescribed in the contract for a class of laborers or mechanics includes a fringe benefit which is not expressed as an hourly rate, the contractor shall either pay the benefit as stated in the wage determination or shall pay another bona fide fringe benefit or an hourly cash equivalent thereof.

d. If the contractor does not make payments to a trustee or other third person, the contractor may consider as part of the wages of any laborer or mechanic the amount of any costs reasonably anticipated in providing bona fide fringe benefits under a plan or program, Provided, That the Secretary of Labor has found, upon the written request of the contractor, that the applicable standards of the Davis-Bacon Act have been met. The Secretary of Labor may require the contractor to set aside in a separate account assets for the meeting of obligations under the plan or program.

2. Withholding (29 CFR 5.5)

The contracting agency shall upon its own action or upon written request of an authorized representative of the Department of Labor, withhold or cause to be withheld from the contractor under this contract, or any other Federal contract with the same prime contractor, or any other federally-assisted contract subject to Davis-Bacon prevailing wage requirements, which is held by the same prime contractor, so much of the accrued payments or advances as may be considered necessary to pay laborers and mechanics,

including apprentices, trainees, and helpers, employed by the contractor or any subcontractor the full amount of wages required by the contract. In the event of failure to pay any laborer or mechanic, including any apprentice, trainee, or helper, employed or working on the site of the work, all or part of the wages required by the contract, the contracting agency may, after written notice to the contractor, take such action as may be necessary to cause the suspension of any further payment, advance, or guarantee of funds until such violations have ceased.

3. Payrolls and basic records (29 CFR 5.5)

a. Payrolls and basic records relating thereto shall be maintained by the contractor during the course of the work and preserved for a period of three years thereafter for all laborers and mechanics working at the site of the work. Such records shall contain the name, address, and social security number of each such worker, his or her correct classification, hourly rates of wages paid (including rates of contributions or costs anticipated for bona fide fringe benefits or cash equivalents thereof of the types described in section 1(b)(2)(B) of the Davis-Bacon Act), daily and weekly number of hours worked, deductions made and actual wages paid. Whenever the Secretary of Labor has found under 29 CFR 5.5(a)(1)(iv) that the wages of any laborer or mechanic include the amount of any costs reasonably anticipated in providing benefits under a plan or program described in section 1(b)(2)(B) of the Davis-Bacon Act, the contractor shall maintain records which show that the commitment to provide such benefits is enforceable, that the plan or program is financially responsible, and that the plan or program has been communicated in writing to the laborers or mechanics affected, and records which show the costs anticipated or the actual cost incurred in providing such benefits. Contractors employing apprentices or trainees under approved programs shall maintain written evidence of the registration of apprenticeship programs and certification of trainee programs, the registration of the apprentices and trainees, and the ratios and wage rates prescribed in the applicable programs.

b.(1) The contractor shall submit weekly for each week in which any contract work is performed a copy of all payrolls to the contracting agency. The payrolls submitted shall set out accurately and completely all of the information required to be maintained under 29 CFR 5.5(a)(3)(i), except that full social security numbers and home addresses shall not be included on weekly transmittals. Instead the payrolls shall only need to include an individually identifying number for each employee (e.g., the last four digits of the employee's social security number). The required weekly payroll information may be submitted in any form desired. Optional Form WH-347 is available for this purpose from the Wage and Hour Division Web site. The prime contractor is responsible for the submission of copies of payrolls by all subcontractors. Contractors and subcontractors shall maintain the full social security number and current address of each covered worker, and shall provide them upon request to the contracting agency for transmission to the State DOT, the FHWA or the Wage and Hour Division of the Department of Labor for purposes of an investigation or audit of compliance with prevailing wage requirements. It is not a violation of this section for a prime contractor to require a subcontractor to provide addresses and social security numbers to the prime contractor for its own records, without weekly submission to the contracting agency.

(2) Each payroll submitted shall be accompanied by a "Statement of Compliance," signed by the contractor or

subcontractor or his or her agent who pays or supervises the payment of the persons employed under the contract and shall certify the following:

(i) That the payroll for the payroll period contains the information required to be provided under 29 CFR 5.5(a)(3)(ii), the appropriate information is being maintained under 29 CFR 5.5(a)(3)(i), and that such information is correct and complete;

(ii) That each laborer or mechanic (including each helper, apprentice, and trainee) employed on the contract during the payroll period has been paid the full weekly wages earned, without rebate, either directly or indirectly, and that no deductions have been made either directly or indirectly from the full wages earned, other than permissible deductions as set forth in 29 CFR part 3;

(iii) That each laborer or mechanic has been paid not less than the applicable wage rates and fringe benefits or cash equivalents for the classification of work performed, as specified in the applicable wage determination incorporated into the contract.

(3) The weekly submission of a properly executed certification set forth on the reverse side of Optional Form WH-347 shall satisfy the requirement for submission of the "Statement of Compliance" required by paragraph 3.b.(2) of this section.

(4) The falsification of any of the above certifications may subject the contractor or subcontractor to civil or criminal prosecution under 18 U.S.C. 1001 and 31 U.S.C. 231.

c. The contractor or subcontractor shall make the records required under paragraph 3.a. of this section available for inspection, copying, or transcription by authorized representatives of the contracting agency, the State DOT, the FHWA, or the Department of Labor, and shall permit such representatives to interview employees during working hours on the job. If the contractor or subcontractor fails to submit the required records or to make them available, the FHWA may, after written notice to the contractor, the contracting agency or the State DOT, take such action as may be necessary to cause the suspension of any further payment, advance, or guarantee of funds. Furthermore, failure to submit the required records upon request or to make such records available may be grounds for debarment action pursuant to 29 CFR 5.12.

4. Apprentices and trainees (29 CFR 5.5)

a. Apprentices (programs of the USDOL).

Apprentices will be permitted to work at less than the predetermined rate for the work they performed when they are employed pursuant to and individually registered in a bona fide apprenticeship program registered with the U.S. Department of Labor, Employment and Training Administration, Office of Apprenticeship Training, Employer and Labor Services, or with a State Apprenticeship Agency recognized by the Office, or if a person is employed in his or her first 90 days of probationary employment as an apprentice in such an apprenticeship program, who is not individually registered in the program, but who has been certified by the Office of Apprenticeship Training, Employer and Labor Services or a State

Apprenticeship Agency (where appropriate) to be eligible for probationary employment as an apprentice.

The allowable ratio of apprentices to journeymen on the job site in any craft classification shall not be greater than the ratio permitted to the contractor as to the entire work force under the registered program. Any worker listed on a payroll at an apprentice wage rate, who is not registered or otherwise employed as stated above, shall be paid not less than the applicable wage rate on the wage determination for the classification of work actually performed. In addition, any apprentice performing work on the job site in excess of the ratio permitted under the registered program shall be paid not less than the applicable wage rate on the wage determination for the work actually performed. Where a contractor is performing construction on a project in a locality other than that in which its program is registered, the ratios and wage rates (expressed in percentages of the journeyman's hourly rate) specified in the contractor's or subcontractor's registered program shall be observed.

Every apprentice must be paid at not less than the rate specified in the registered program for the apprentice's level of progress, expressed as a percentage of the journeymen hourly rate specified in the applicable wage determination. Apprentices shall be paid fringe benefits in accordance with the provisions of the apprenticeship program. If the apprenticeship program does not specify fringe benefits, apprentices must be paid the full amount of fringe benefits listed on the wage determination for the applicable classification. If the Administrator determines that a different practice prevails for the applicable apprentice classification, fringes shall be paid in accordance with that determination.

In the event the Office of Apprenticeship Training, Employer and Labor Services, or a State Apprenticeship Agency recognized by the Office, withdraws approval of an apprenticeship program, the contractor will no longer be permitted to utilize apprentices at less than the applicable predetermined rate for the work performed until an acceptable program is approved.

b. Trainees (programs of the USDOL).

Except as provided in 29 CFR 5.16, trainees will not be permitted to work at less than the predetermined rate for the work performed unless they are employed pursuant to and individually registered in a program which has received prior approval, evidenced by formal certification by the U.S. Department of Labor, Employment and Training Administration.

The ratio of trainees to journeymen on the job site shall not be greater than permitted under the plan approved by the Employment and Training Administration.

Every trainee must be paid at not less than the rate specified in the approved program for the trainee's level of progress, expressed as a percentage of the journeyman hourly rate specified in the applicable wage determination. Trainees shall be paid fringe benefits in accordance with the provisions of the trainee program. If the trainee program does not mention fringe benefits, trainees shall be paid the full amount of fringe benefits listed on the wage determination unless the Administrator of the Wage and Hour Division determines that there is an apprenticeship program associated with the

corresponding journeyman wage rate on the wage determination which provides for less than full fringe benefits for apprentices. Any employee listed on the payroll at a trainee rate who is not registered and participating in a training plan approved by the Employment and Training Administration shall be paid not less than the applicable wage rate on the wage determination for the classification of work actually performed. In addition, any trainee performing work on the job site in excess of the ratio permitted under the registered program shall be paid not less than the applicable wage rate on the wage determination for the work actually performed.

In the event the Employment and Training Administration withdraws approval of a training program, the contractor will no longer be permitted to utilize trainees at less than the applicable predetermined rate for the work performed until an acceptable program is approved.

c. Equal employment opportunity. The utilization of apprentices, trainees and journeymen under this part shall be in conformity with the equal employment opportunity requirements of Executive Order 11246, as amended, and 29 CFR part 30.

d. Apprentices and Trainees (programs of the U.S. DOT).

Apprentices and trainees working under apprenticeship and skill training programs which have been certified by the Secretary of Transportation as promoting EEO in connection with Federal-aid highway construction programs are not subject to the requirements of paragraph 4 of this Section IV. 23 CFR 230.111(e)(2). The straight time hourly wage rates for apprentices and trainees under such programs will be established by the particular programs. The ratio of apprentices and trainees to journeymen shall not be greater than permitted by the terms of the particular program.

5. Compliance with Copeland Act requirements. The contractor shall comply with the requirements of 29 CFR part 3, which are incorporated by reference in this contract as provided in 29 CFR 5.5.

6. Subcontracts. The contractor or subcontractor shall insert Form FHWA-1273 in any subcontracts and also require the subcontractors to include Form FHWA-1273 in any lower tier subcontracts. The prime contractor shall be responsible for the compliance by any subcontractor or lower tier subcontractor with all the contract clauses in 29 CFR 5.5.

7. Contract termination: debarment. A breach of the contract clauses in 29 CFR 5.5 may be grounds for termination of the contract, and for debarment as a contractor and a subcontractor as provided in 29 CFR 5.12.

8. Compliance with Davis-Bacon and Related Act requirements. All rulings and interpretations of the Davis-Bacon and Related Acts contained in 29 CFR parts 1, 3, and 5 are herein incorporated by reference in this contract as provided in 29 CFR 5.5.

9. Disputes concerning labor standards. As provided in 29 CFR 5.5, disputes arising out of the labor standards provisions of this contract shall not be subject to the general disputes clause of this contract. Such disputes shall be resolved in accordance with the procedures of the Department of Labor

set forth in 29 CFR parts 5, 6, and 7. Disputes within the meaning of this clause include disputes between the contractor (or any of its subcontractors) and the contracting agency, the U.S. Department of Labor, or the employees or their representatives.

10. Certification of eligibility (29 CFR 5.5)

a. By entering into this contract, the contractor certifies that neither it (nor he or she) nor any person or firm who has an interest in the contractor's firm is a person or firm ineligible to be awarded Government contracts by virtue of section 3(a) of the Davis-Bacon Act or 29 CFR 5.12(a)(1).

b. No part of this contract shall be subcontracted to any person or firm ineligible for award of a Government contract by virtue of section 3(a) of the Davis-Bacon Act or 29 CFR 5.12(a)(1).

c. The penalty for making false statements is prescribed in the U.S. Criminal Code, 18 U.S.C. 1001.

V. CONTRACT WORK HOURS AND SAFETY STANDARDS ACT

Pursuant to 29 CFR 5.5(b), the following clauses apply to any Federal-aid construction contract in an amount in excess of \$100,000 and subject to the overtime provisions of the Contract Work Hours and Safety Standards Act. These clauses shall be inserted in addition to the clauses required by 29 CFR 5.5(a) or 29 CFR 4.6. As used in this paragraph, the terms laborers and mechanics include watchmen and guards.

1. Overtime requirements. No contractor or subcontractor contracting for any part of the contract work which may require or involve the employment of laborers or mechanics shall require or permit any such laborer or mechanic in any workweek in which he or she is employed on such work to work in excess of forty hours in such workweek unless such laborer or mechanic receives compensation at a rate not less than one and one-half times the basic rate of pay for all hours worked in excess of forty hours in such workweek. 29 CFR 5.5.

2. Violation; liability for unpaid wages; liquidated damages. In the event of any violation of the clause set forth in paragraph 1 of this section, the contractor and any subcontractor responsible therefor shall be liable for the unpaid wages. In addition, such contractor and subcontractor shall be liable to the United States (in the case of work done under contract for the District of Columbia or a territory, to such District or to such territory), for liquidated damages. Such liquidated damages shall be computed with respect to each individual laborer or mechanic, including watchmen and guards, employed in violation of the clause set forth in paragraph 1 of this section, in the sum currently provided in 29 CFR 5.5(b)(2)* for each calendar day on which such individual was required or permitted to work in excess of the standard workweek of forty hours without payment of the overtime wages required by the clause set forth in paragraph 1 of this section. 29 CFR 5.5.

* \$27 as of January 23, 2019 (See 84 FR 213-01, 218) as may be adjusted annually by the Department of Labor; pursuant to the Federal Civil Penalties Inflation Adjustment Act of 1990).

3. Withholding for unpaid wages and liquidated damages.

The FHWA or the contracting agency shall upon its own action or upon written request of an authorized representative of the Department of Labor withhold or cause to be withheld, from any moneys payable on account of work performed by the contractor or subcontractor under any such contract or any other Federal contract with the same prime contractor, or any other federally-assisted contract subject to the Contract Work Hours and Safety Standards Act, which is held by the same prime contractor, such sums as may be determined to be necessary to satisfy any liabilities of such contractor or subcontractor for unpaid wages and liquidated damages as provided in the clause set forth in paragraph 2 of this section. 29 CFR 5.5.

4. Subcontracts. The contractor or subcontractor shall insert in any subcontracts the clauses set forth in paragraphs 1 through 4 of this section and also a clause requiring the subcontractors to include these clauses in any lower tier subcontracts. The prime contractor shall be responsible for compliance by any subcontractor or lower tier subcontractor with the clauses set forth in paragraphs 1 through 4 of this section. 29 CFR 5.5.

VI. SUBLETTING OR ASSIGNING THE CONTRACT

This provision is applicable to all Federal-aid construction contracts on the National Highway System pursuant to 23 CFR 635.116.

1. The contractor shall perform with its own organization contract work amounting to not less than 30 percent (or a greater percentage if specified elsewhere in the contract) of the total original contract price, excluding any specialty items designated by the contracting agency. Specialty items may be performed by subcontract and the amount of any such specialty items performed may be deducted from the total original contract price before computing the amount of work required to be performed by the contractor's own organization (23 CFR 635.116).

a. The term "perform work with its own organization" in paragraph 1 of Section VI refers to workers employed or leased by the prime contractor, and equipment owned or rented by the prime contractor, with or without operators. Such term does not include employees or equipment of a subcontractor or lower tier subcontractor, agents of the prime contractor, or any other assignees. The term may include payments for the costs of hiring leased employees from an employee leasing firm meeting all relevant Federal and State regulatory requirements. Leased employees may only be included in this term if the prime contractor meets all of the following conditions: (based on longstanding interpretation)

- (1) the prime contractor maintains control over the supervision of the day-to-day activities of the leased employees;
- (2) the prime contractor remains responsible for the quality of the work of the leased employees;
- (3) the prime contractor retains all power to accept or exclude individual employees from work on the project; and
- (4) the prime contractor remains ultimately responsible for the payment of predetermined minimum wages, the submission of payrolls, statements of compliance and all other Federal regulatory requirements.

b. "Specialty Items" shall be construed to be limited to work that requires highly specialized knowledge, abilities, or

equipment not ordinarily available in the type of contracting organizations qualified and expected to bid or propose on the contract as a whole and in general are to be limited to minor components of the overall contract. 23 CFR 635.102.

2. Pursuant to 23 CFR 635.116(a), the contract amount upon which the requirements set forth in paragraph (1) of Section VI is computed includes the cost of material and manufactured products which are to be purchased or produced by the contractor under the contract provisions.

3. Pursuant to 23 CFR 635.116(c), the contractor shall furnish (a) a competent superintendent or supervisor who is employed by the firm, has full authority to direct performance of the work in accordance with the contract requirements, and is in charge of all construction operations (regardless of who performs the work) and (b) such other of its own organizational resources (supervision, management, and engineering services) as the contracting officer determines is necessary to assure the performance of the contract.

4. No portion of the contract shall be sublet, assigned or otherwise disposed of except with the written consent of the contracting officer, or authorized representative, and such consent when given shall not be construed to relieve the contractor of any responsibility for the fulfillment of the contract. Written consent will be given only after the contracting agency has assured that each subcontract is evidenced in writing and that it contains all pertinent provisions and requirements of the prime contract. (based on longstanding interpretation of 23 CFR 635.116).

5. The 30-percent self-performance requirement of paragraph (1) is not applicable to design-build contracts; however, contracting agencies may establish their own self-performance requirements. 23 CFR 635.116(d).

VII. SAFETY: ACCIDENT PREVENTION

This provision is applicable to all Federal-aid construction contracts and to all related subcontracts.

1. In the performance of this contract the contractor shall comply with all applicable Federal, State, and local laws governing safety, health, and sanitation (23 CFR Part 635). The contractor shall provide all safeguards, safety devices and protective equipment and take any other needed actions as it determines, or as the contracting officer may determine, to be reasonably necessary to protect the life and health of employees on the job and the safety of the public and to protect property in connection with the performance of the work covered by the contract. 23 CFR 635.108.

2. It is a condition of this contract, and shall be made a condition of each subcontract, which the contractor enters into pursuant to this contract, that the contractor and any subcontractor shall not permit any employee, in performance of the contract, to work in surroundings or under conditions which are unsanitary, hazardous or dangerous to his/her health or safety, as determined under construction safety and health standards (29 CFR Part 1926) promulgated by the Secretary of Labor, in accordance with Section 107 of the Contract Work Hours and Safety Standards Act (40 U.S.C. 3704). 29 CFR 1926.10.

3. Pursuant to 29 CFR 1926.3, it is a condition of this contract that the Secretary of Labor or authorized representative thereof, shall have right of entry to any site of contract performance to inspect or investigate the matter of compliance

with the construction safety and health standards and to carry out the duties of the Secretary under Section 107 of the Contract Work Hours and Safety Standards Act (40 U.S.C. 3704).

VIII. FALSE STATEMENTS CONCERNING HIGHWAY PROJECTS

This provision is applicable to all Federal-aid construction contracts and to all related subcontracts.

In order to assure high quality and durable construction in conformity with approved plans and specifications and a high degree of reliability on statements and representations made by engineers, contractors, suppliers, and workers on Federal-aid highway projects, it is essential that all persons concerned with the project perform their functions as carefully, thoroughly, and honestly as possible. Willful falsification, distortion, or misrepresentation with respect to any facts related to the project is a violation of Federal law. To prevent any misunderstanding regarding the seriousness of these and similar acts, Form FHWA-1022 shall be posted on each Federal-aid highway project (23 CFR Part 635) in one or more places where it is readily available to all persons concerned with the project:

18 U.S.C. 1020 reads as follows:

"Whoever, being an officer, agent, or employee of the United States, or of any State or Territory, or whoever, whether a person, association, firm, or corporation, knowingly makes any false statement, false representation, or false report as to the character, quality, quantity, or cost of the material used or to be used, or the quantity or quality of the work performed or to be performed, or the cost thereof in connection with the submission of plans, maps, specifications, contracts, or costs of construction on any highway or related project submitted for approval to the Secretary of Transportation; or

Whoever knowingly makes any false statement, false representation, false report or false claim with respect to the character, quality, quantity, or cost of any work performed or to be performed, or materials furnished or to be furnished, in connection with the construction of any highway or related project approved by the Secretary of Transportation; or

Whoever knowingly makes any false statement or false representation as to material fact in any statement, certificate, or report submitted pursuant to provisions of the Federal-aid Roads Act approved July 11, 1916, (39 Stat. 355), as amended and supplemented;

Shall be fined under this title or imprisoned not more than 5 years or both."

IX. IMPLEMENTATION OF CLEAN AIR ACT AND FEDERAL WATER POLLUTION CONTROL ACT (42 U.S.C. 7606; 2 CFR 200.88; EO 11738)

This provision is applicable to all Federal-aid construction contracts in excess of \$150,000 and to all related subcontracts. 48 CFR 2.101; 2 CFR 200.326.

By submission of this bid/proposal or the execution of this contract or subcontract, as appropriate, the bidder, proposer, Federal-aid construction contractor, subcontractor, supplier, or vendor agrees to comply with all applicable standards, orders

or regulations issued pursuant to the Clean Air Act (42 U.S.C. 7401-7671q) and the Federal Water Pollution Control Act, as amended (33 U.S.C. 1251-1387). Violations must be reported to the Federal Highway Administration and the Regional Office of the Environmental Protection Agency. 2 CFR Part 200, Appendix II.

The contractor agrees to include or cause to be included the requirements of this Section in every subcontract, and further agrees to take such action as the contracting agency may direct as a means of enforcing such requirements. 2 CFR 200.326.

X. CERTIFICATION REGARDING DEBARMENT, SUSPENSION, INELIGIBILITY AND VOLUNTARY EXCLUSION

This provision is applicable to all Federal-aid construction contracts, design-build contracts, subcontracts, lower-tier subcontracts, purchase orders, lease agreements, consultant contracts or any other covered transaction requiring FHWA approval or that is estimated to cost \$25,000 or more – as defined in 2 CFR Parts 180 and 1200. 2 CFR 180.220 and 1200.220.

1. Instructions for Certification – First Tier Participants:

a. By signing and submitting this proposal, the prospective first tier participant is providing the certification set out below.

b. The inability of a person to provide the certification set out below will not necessarily result in denial of participation in this covered transaction. The prospective first tier participant shall submit an explanation of why it cannot provide the certification set out below. The certification or explanation will be considered in connection with the department or agency's determination whether to enter into this transaction. However, failure of the prospective first tier participant to furnish a certification or an explanation shall disqualify such a person from participation in this transaction. 2 CFR 180.320.

c. The certification in this clause is a material representation of fact upon which reliance was placed when the contracting agency determined to enter into this transaction. If it is later determined that the prospective participant knowingly rendered an erroneous certification, in addition to other remedies available to the Federal Government, the contracting agency may terminate this transaction for cause of default. 2 CFR 180.325.

d. The prospective first tier participant shall provide immediate written notice to the contracting agency to whom this proposal is submitted if any time the prospective first tier participant learns that its certification was erroneous when submitted or has become erroneous by reason of changed circumstances. 2 CFR 180.345 and 180.350.

e. The terms "covered transaction," "debarred," "suspended," "ineligible," "participant," "person," "principal," and "voluntarily excluded," as used in this clause, are defined in 2 CFR Parts 180, Subpart I, 180.900-180.1020, and 1200. "First Tier Covered Transactions" refers to any covered transaction between a recipient or subrecipient of Federal funds and a participant (such as the prime or general contract). "Lower Tier Covered Transactions" refers to any covered transaction under a First Tier Covered Transaction (such as subcontracts). "First Tier Participant" refers to the participant

who has entered into a covered transaction with a recipient or subrecipient of Federal funds (such as the prime or general contractor). "Lower Tier Participant" refers any participant who has entered into a covered transaction with a First Tier Participant or other Lower Tier Participants (such as subcontractors and suppliers).

f. The prospective first tier participant agrees by submitting this proposal that, should the proposed covered transaction be entered into, it shall not knowingly enter into any lower tier covered transaction with a person who is debarred, suspended, declared ineligible, or voluntarily excluded from participation in this covered transaction, unless authorized by the department or agency entering into this transaction. 2 CFR 180.330.

g. The prospective first tier participant further agrees by submitting this proposal that it will include the clause titled "Certification Regarding Debarment, Suspension, Ineligibility and Voluntary Exclusion-Lower Tier Covered Transactions," provided by the department or contracting agency, entering into this covered transaction, without modification, in all lower tier covered transactions and in all solicitations for lower tier covered transactions exceeding the \$25,000 threshold. 2 CFR 180.220 and 180.300.

h. A participant in a covered transaction may rely upon a certification of a prospective participant in a lower tier covered transaction that is not debarred, suspended, ineligible, or voluntarily excluded from the covered transaction, unless it knows that the certification is erroneous. 2 CFR 180.300; 180.320, and 180.325. A participant is responsible for ensuring that its principals are not suspended, debarred, or otherwise ineligible to participate in covered transactions. 2 CFR 180.335. To verify the eligibility of its principals, as well as the eligibility of any lower tier prospective participants, each participant may, but is not required to, check the System for Award Management website (<https://www.sam.gov/>). 2 CFR 180.300, 180.320, and 180.325.

i. Nothing contained in the foregoing shall be construed to require the establishment of a system of records in order to render in good faith the certification required by this clause. The knowledge and information of the prospective participant is not required to exceed that which is normally possessed by a prudent person in the ordinary course of business dealings.

j. Except for transactions authorized under paragraph (f) of these instructions, if a participant in a covered transaction knowingly enters into a lower tier covered transaction with a person who is suspended, debarred, ineligible, or voluntarily excluded from participation in this transaction, in addition to other remedies available to the Federal Government, the department or agency may terminate this transaction for cause or default. 2 CFR 180.325.

2. Certification Regarding Debarment, Suspension, Ineligibility and Voluntary Exclusion – First Tier Participants:

a. The prospective first tier participant certifies to the best of its knowledge and belief, that it and its principals:

(1) Are not presently debarred, suspended, proposed for debarment, declared ineligible, or voluntarily excluded from participating in covered transactions by any Federal department or agency, 2 CFR 180.335;.

(2) Have not within a three-year period preceding this proposal been convicted of or had a civil judgment rendered against them for commission of fraud or a criminal offense in connection with obtaining, attempting to obtain, or performing a public (Federal, State, or local) transaction or contract under a public transaction; violation of Federal or State antitrust statutes or commission of embezzlement, theft, forgery, bribery, falsification or destruction of records, making false statements, or receiving stolen property, 2 CFR 180.800;

(3) Are not presently indicted for or otherwise criminally or civilly charged by a governmental entity (Federal, State or local) with commission of any of the offenses enumerated in paragraph (a)(2) of this certification, 2 CFR 180.700 and 180.800; and

(4) Have not within a three-year period preceding this application/proposal had one or more public transactions (Federal, State or local) terminated for cause or default. 2 CFR 180.335(d).

(5) Are not a corporation that has been convicted of a felony violation under any Federal law within the two-year period preceding this proposal (USDOT Order 4200.6 implementing appropriations act requirements); and

(6) Are not a corporation with any unpaid Federal tax liability that has been assessed, for which all judicial and administrative remedies have been exhausted, or have lapsed, and that is not being paid in a timely manner pursuant to an agreement with the authority responsible for collecting the tax liability (USDOT Order 4200.6 implementing appropriations act requirements).

b. Where the prospective participant is unable to certify to any of the statements in this certification, such prospective participant should attach an explanation to this proposal. 2 CFR 180.335 and 180.340.

3. Instructions for Certification - Lower Tier Participants:

(Applicable to all subcontracts, purchase orders, and other lower tier transactions requiring prior FHWA approval or estimated to cost \$25,000 or more - 2 CFR Parts 180 and 1200). 2 CFR 180.220 and 1200.220.

a. By signing and submitting this proposal, the prospective lower tier participant is providing the certification set out below.

b. The certification in this clause is a material representation of fact upon which reliance was placed when this transaction was entered into. If it is later determined that the prospective lower tier participant knowingly rendered an erroneous certification, in addition to other remedies available to the Federal Government, the department, or agency with which this transaction originated may pursue available remedies, including suspension and/or debarment.

c. The prospective lower tier participant shall provide immediate written notice to the person to which this proposal is submitted if at any time the prospective lower tier participant learns that its certification was erroneous by reason of changed circumstances. 2 CFR 180.365.

d. The terms "covered transaction," "debarred," "suspended," "ineligible," "participant," "person," "principal," and "voluntarily excluded," as used in this clause, are defined in 2 CFR Parts 180, Subpart I, 180.900 – 180.1020, and 1200. You may contact the person to which this proposal is

submitted for assistance in obtaining a copy of those regulations. "First Tier Covered Transactions" refers to any covered transaction between a recipient or subrecipient of Federal funds and a participant (such as the prime or general contractor). "Lower Tier Covered Transactions" refers to any covered transaction under a First Tier Covered Transaction (such as subcontracts). "First Tier Participant" refers to the participant who has entered into a covered transaction with a recipient or subrecipient of Federal funds (such as the prime or general contractor). "Lower Tier Participant" refers any participant who has entered into a covered transaction with a First Tier Participant or other Lower Tier Participants (such as subcontractors and suppliers).

e. The prospective lower tier participant agrees by submitting this proposal that, should the proposed covered transaction be entered into, it shall not knowingly enter into any lower tier covered transaction with a person who is debarred, suspended, declared ineligible, or voluntarily excluded from participation in this covered transaction, unless authorized by the department or agency with which this transaction originated. 2 CFR 1200.220 and 1200.332.

f. The prospective lower tier participant further agrees by submitting this proposal that it will include this clause titled "Certification Regarding Debarment, Suspension, Ineligibility and Voluntary Exclusion-Lower Tier Covered Transaction," without modification, in all lower tier covered transactions and in all solicitations for lower tier covered transactions exceeding the \$25,000 threshold. 2 CFR 180.220 and 1200.220.

g. A participant in a covered transaction may rely upon a certification of a prospective participant in a lower tier covered transaction that is not debarred, suspended, ineligible, or voluntarily excluded from the covered transaction, unless it knows that the certification is erroneous. A participant is responsible for ensuring that its principals are not suspended, debarred, or otherwise ineligible to participate in covered transactions. To verify the eligibility of its principals, as well as the eligibility of any lower tier prospective participants, each participant may, but is not required to, check the System for Award Management website (<https://www.sam.gov/>), which is compiled by the General Services Administration. 2 CFR 180.300, 180.320, 180.330, and 180.335.

h. Nothing contained in the foregoing shall be construed to require establishment of a system of records in order to render in good faith the certification required by this clause. The knowledge and information of participant is not required to exceed that which is normally possessed by a prudent person in the ordinary course of business dealings.

i. Except for transactions authorized under paragraph e of these instructions, if a participant in a covered transaction knowingly enters into a lower tier covered transaction with a person who is suspended, debarred, ineligible, or voluntarily excluded from participation in this transaction, in addition to other remedies available to the Federal Government, the department or agency with which this transaction originated may pursue available remedies, including suspension and/or debarment. 2 CFR 180.325.

Certification Regarding Debarment, Suspension, Ineligibility and Voluntary Exclusion--Lower Tier Participants:

1. The prospective lower tier participant certifies, by submission of this proposal, that neither it nor its principals:

(a) is presently debarred, suspended, proposed for debarment, declared ineligible, or voluntarily excluded from participating in covered transactions by any Federal department or agency, 2 CFR 180.355;

(b) is a corporation that has been convicted of a felony violation under any Federal law within the two-year period preceding this proposal (USDOT Order 4200.6 implementing appropriations act requirements); and

(c) is a corporation with any unpaid Federal tax liability that has been assessed, for which all judicial and administrative remedies have been exhausted, or have lapsed, and that is not being paid in a timely manner pursuant to an agreement with the authority responsible for collecting the tax liability. (USDOT Order 4200.6 implementing appropriations act requirements)

2. Where the prospective lower tier participant is unable to certify to any of the statements in this certification, such prospective participant should attach an explanation to this proposal.

XI. CERTIFICATION REGARDING USE OF CONTRACT FUNDS FOR LOBBYING

This provision is applicable to all Federal-aid construction contracts and to all related subcontracts which exceed \$100,000. 49 CFR Part 20, App. A.

1. The prospective participant certifies, by signing and submitting this bid or proposal, to the best of his or her knowledge and belief, that:

a. No Federal appropriated funds have been paid or will be paid, by or on behalf of the undersigned, to any person for influencing or attempting to influence an officer or employee of any Federal agency, a Member of Congress, an officer or employee of Congress, or an employee of a Member of Congress in connection with the awarding of any Federal contract, the making of any Federal grant, the making of any Federal loan, the entering into of any cooperative agreement, and the extension, continuation, renewal, amendment, or modification of any Federal contract, grant, loan, or cooperative agreement.

b. If any funds other than Federal appropriated funds have been paid or will be paid to any person for influencing or attempting to influence an officer or employee of any Federal agency, a Member of Congress, an officer or employee of Congress, or an employee of a Member of Congress in connection with this Federal contract, grant, loan, or cooperative agreement, the undersigned shall complete and submit Standard Form-LLL, "Disclosure Form to Report Lobbying," in accordance with its instructions.

2. This certification is a material representation of fact upon which reliance was placed when this transaction was made or entered into. Submission of this certification is a prerequisite for making or entering into this transaction imposed by 31 U.S.C. 1352. Any person who fails to file the required certification shall be subject to a civil penalty of not less than \$10,000 and not more than \$100,000 for each such failure.

3. The prospective participant also agrees by submitting its bid or proposal that the participant shall require that the language of this certification be included in all lower tier

subcontracts, which exceed \$100,000 and that all such recipients shall certify and disclose accordingly.

XII. USE OF UNITED STATES-FLAG VESSELS:

This provision is applicable to all Federal-aid construction contracts, design-build contracts, subcontracts, lower-tier subcontracts, purchase orders, lease agreements, or any other covered transaction. 46 CFR Part 381.

This requirement applies to material or equipment that is acquired for a specific Federal-aid highway project. 46 CFR 381.7. It is not applicable to goods or materials that come into inventories independent of an FHWA funded-contract.

When oceanic shipments (or shipments across the Great Lakes) are necessary for materials or equipment acquired for a specific Federal-aid construction project, the bidder, proposer, contractor, subcontractor, or vendor agrees:

1. To utilize privately owned United States-flag commercial vessels to ship at least 50 percent of the gross tonnage (computed separately for dry bulk carriers, dry cargo liners, and tankers) involved, whenever shipping any equipment, material, or commodities pursuant to this contract, to the extent such vessels are available at fair and reasonable rates for United States-flag commercial vessels. 46 CFR 381.7.
2. To furnish within 20 days following the date of loading for shipments originating within the United States or within 30 working days following the date of loading for shipments originating outside the United States, a legible copy of a rated, 'on-board' commercial ocean bill-of-lading in English for each shipment of cargo described in paragraph (b)(1) of this section to both the Contracting Officer (through the prime contractor in the case of subcontractor bills-of-lading) and to the Office of Cargo and Commercial Sealift (MAR-620), Maritime Administration, Washington, DC 20590. (MARAD requires copies of the ocean carrier's (master) bills of lading, certified onboard, dated, with rates and charges. These bills of lading may contain business sensitive information and therefore may be submitted directly to MARAD by the Ocean Transportation Intermediary on behalf of the contractor). 46 CFR 381.7.

**ATTACHMENT A - EMPLOYMENT AND MATERIALS
PREFERENCE FOR APPALACHIAN DEVELOPMENT
HIGHWAY SYSTEM OR APPALACHIAN LOCAL ACCESS
ROAD CONTRACTS (23 CFR 633, Subpart B, Appendix B)**

This provision is applicable to all Federal-aid projects funded under the Appalachian Regional Development Act of 1965.

1. During the performance of this contract, the contractor undertaking to do work which is, or reasonably may be, done as on-site work, shall give preference to qualified persons who regularly reside in the labor area as designated by the DOL wherein the contract work is situated, or the subregion, or the Appalachian counties of the State wherein the contract work is situated, except:

a. To the extent that qualified persons regularly residing in the area are not available.

b. For the reasonable needs of the contractor to employ supervisory or specially experienced personnel necessary to assure an efficient execution of the contract work.

c. For the obligation of the contractor to offer employment to present or former employees as the result of a lawful collective bargaining contract, provided that the number of nonresident persons employed under this subparagraph (1c) shall not exceed 20 percent of the total number of employees employed by the contractor on the contract work, except as provided in subparagraph (4) below.

2. The contractor shall place a job order with the State Employment Service indicating (a) the classifications of the laborers, mechanics and other employees required to perform the contract work, (b) the number of employees required in each classification, (c) the date on which the participant estimates such employees will be required, and (d) any other pertinent information required by the State Employment Service to complete the job order form. The job order may be placed with the State Employment Service in writing or by telephone. If during the course of the contract work, the information submitted by the contractor in the original job order is substantially modified, the participant shall promptly notify the State Employment Service.

3. The contractor shall give full consideration to all qualified job applicants referred to him by the State Employment Service. The contractor is not required to grant employment to any job applicants who, in his opinion, are not qualified to perform the classification of work required.

4. If, within one week following the placing of a job order by the contractor with the State Employment Service, the State Employment Service is unable to refer any qualified job applicants to the contractor, or less than the number requested, the State Employment Service will forward a certificate to the contractor indicating the unavailability of applicants. Such certificate shall be made a part of the contractor's permanent project records. Upon receipt of this certificate, the contractor may employ persons who do not normally reside in the labor area to fill positions covered by the certificate, notwithstanding the provisions of subparagraph (1c) above.

5. The provisions of 23 CFR 633.207(e) allow the contracting agency to provide a contractual preference for the use of mineral resource materials native to the Appalachian region.

6. The contractor shall include the provisions of Sections 1 through 4 of this Attachment A in every subcontract for work which is, or reasonably may be, done as on-site work.

APPENDIX E

**GENERAL WAGE
DECISION NUMBER:
FL220230170
01/06/2023**

"General Decision Number: FL20230170 01/06/2023

Superseded General Decision Number: FL20220170

State: Florida

Construction Type: Highway

County: Indian River County in Florida.

HIGHWAY CONSTRUCTION PROJECTS

Note: Contracts subject to the Davis-Bacon Act are generally required to pay at least the applicable minimum wage rate required under Executive Order 14026 or Executive Order 13658. Please note that these Executive Orders apply to covered contracts entered into by the federal government that are subject to the Davis-Bacon Act itself, but do not apply to contracts subject only to the Davis-Bacon Related Acts, including those set forth at 29 CFR 5.1(a)(2)-(60).

<p>If the contract is entered into on or after January 30, 2022, or the contract is renewed or extended (e.g., an option is exercised) on or after January 30, 2022:</p>	<ul style="list-style-type: none"> . Executive Order 14026 generally applies to the contract. . The contractor must pay all covered workers at least \$16.20 per hour (or the applicable wage rate listed on this wage determination, if it is higher) for all hours spent performing on the contract in 2023.
<p>If the contract was awarded on or between January 1, 2015 and January 29, 2022, and the contract is not renewed or extended on or after January 30, 2022:</p>	<ul style="list-style-type: none"> . Executive Order 13658 generally applies to the contract. . The contractor must pay all covered workers at least \$12.15 per hour (or the applicable wage rate listed on this wage determination, if it is higher) for all hours spent performing on that contract in 2023.

The applicable Executive Order minimum wage rate will be adjusted annually. If this contract is covered by one of the Executive Orders and a classification considered necessary for performance of work on the contract does not appear on this wage determination, the contractor must still submit a conformance request.

Additional information on contractor requirements and worker protections under the Executive Orders is available at <http://www.dol.gov/whd/govcontracts>.

Modification Number Publication Date
 0 01/06/2023

ELEC0915-004 12/05/2022

	Rates	Fringes
ELECTRICIAN.....	\$ 32.56	42%+\$0.35

SUFL2013-031 08/19/2013		

	Rates	Fringes
CARPENTER.....	\$ 15.68 **	0.00
CEMENT MASON/CONCRETE FINISHER, Includes Form Work.....	\$ 15.01 **	0.00
HIGHWAY/PARKING LOT STRIPING: Operator (Striping Machine).....	\$ 15.57 **	0.00
HIGHWAY/PARKING LOT STRIPING: Painter.....	\$ 12.13 **	0.00
IRONWORKER, ORNAMENTAL.....	\$ 13.48 **	0.00
IRONWORKER, REINFORCING.....	\$ 15.38 **	0.00
IRONWORKER, STRUCTURAL.....	\$ 16.42	0.00
LABORER (Traffic Control Specialist).....	\$ 11.79 **	0.00
LABORER: Asphalt, Includes Raker, Shoveler, Spreader and Distributor.....	\$ 14.05 **	0.00
LABORER: Common or General.....	\$ 10.69 **	0.00
LABORER: Flagger.....	\$ 13.09 **	0.00
LABORER: Grade Checker.....	\$ 14.66 **	0.00
LABORER: Mason Tender - Cement/Concrete.....	\$ 12.58 **	0.00
LABORER: Pipelayer.....	\$ 12.44 **	0.00
OPERATOR: Backhoe/Excavator/Trackhoe.....	\$ 14.96 **	0.00
OPERATOR: Bobcat/Skid Steer/Skid Loader.....	\$ 12.88 **	0.00
OPERATOR: Broom/Sweeper.....	\$ 12.91 **	0.00
OPERATOR: Bulldozer.....	\$ 15.23 **	0.00
OPERATOR: Concrete Finishing Machine.....	\$ 15.44 **	0.00
OPERATOR: Crane.....	\$ 22.04	0.00
OPERATOR: Curb Machine.....	\$ 18.45	0.00
OPERATOR: Drill.....	\$ 13.04 **	0.00
OPERATOR: Forklift.....	\$ 10.43 **	0.00

OPERATOR: Gradall.....	\$ 14.71 **	0.00
OPERATOR: Grader/Blade.....	\$ 18.20	0.00
OPERATOR: Loader.....	\$ 13.14 **	0.00
OPERATOR: Mechanic.....	\$ 17.52	0.00
OPERATOR: Milling Machine.....	\$ 16.04 **	0.00
OPERATOR: Oiler.....	\$ 16.67	0.00
OPERATOR: Paver (Asphalt, Aggregate, and Concrete).....	\$ 15.47 **	0.00
OPERATOR: Piledriver.....	\$ 17.23	0.00
OPERATOR: Post Driver (Guardrail/Fences).....	\$ 15.97 **	0.00
OPERATOR: Roller.....	\$ 12.50 **	0.00
OPERATOR: Scraper.....	\$ 12.21 **	0.00
OPERATOR: Screed.....	\$ 14.14 **	0.00
OPERATOR: Trencher.....	\$ 14.25 **	0.00
PAINTER: Spray.....	\$ 19.57	0.00
TRAFFIC SIGNALIZATION: Traffic Signal Installation.....	\$ 15.11 **	0.00
TRUCK DRIVER: Dump Truck.....	\$ 11.86 **	0.00
TRUCK DRIVER: Flatbed Truck.....	\$ 14.28 **	0.00
TRUCK DRIVER: Lowboy Truck.....	\$ 16.25	0.00
TRUCK DRIVER: Slurry Truck.....	\$ 11.96 **	0.00
TRUCK DRIVER: Water Truck.....	\$ 13.57 **	0.00

WELDERS - Receive rate prescribed for craft performing operation to which welding is incidental.

=====
** Workers in this classification may be entitled to a higher minimum wage under Executive Order 14026 (\$16.20) or 13658 (\$12.15). Please see the Note at the top of the wage determination for more information.

Note: Executive Order (EO) 13706, Establishing Paid Sick Leave for Federal Contractors applies to all contracts subject to the Davis-Bacon Act for which the contract is awarded (and any solicitation was issued) on or after January 1, 2017. If this contract is covered by the EO, the contractor must provide employees with 1 hour of paid sick leave for every 30 hours they work, up to 56 hours of paid sick leave each year. Employees must be permitted to use paid sick leave for their own illness, injury or other health-related needs, including preventive care; to assist a family member (or person who is like family to the employee) who is ill, injured, or has other

health-related needs, including preventive care; or for reasons resulting from, or to assist a family member (or person who is like family to the employee) who is a victim of, domestic violence, sexual assault, or stalking. Additional information on contractor requirements and worker protections under the EO is available at <https://www.dol.gov/agencies/whd/government-contracts>.

Unlisted classifications needed for work not included within the scope of the classifications listed may be added after award only as provided in the labor standards contract clauses (29CFR 5.5 (a) (1) (ii)).

The body of each wage determination lists the classification and wage rates that have been found to be prevailing for the cited type(s) of construction in the area covered by the wage determination. The classifications are listed in alphabetical order of ""identifiers"" that indicate whether the particular rate is a union rate (current union negotiated rate for local), a survey rate (weighted average rate) or a union average rate (weighted union average rate).

Union Rate Identifiers

A four letter classification abbreviation identifier enclosed in dotted lines beginning with characters other than ""SU"" or ""UAVG"" denotes that the union classification and rate were prevailing for that classification in the survey. Example: PLUM0198-005 07/01/2014. PLUM is an abbreviation identifier of the union which prevailed in the survey for this classification, which in this example would be Plumbers. 0198 indicates the local union number or district council number where applicable, i.e., Plumbers Local 0198. The next number, 005 in the example, is an internal number used in processing the wage determination. 07/01/2014 is the effective date of the most current negotiated rate, which in this example is July 1, 2014.

Union prevailing wage rates are updated to reflect all rate changes in the collective bargaining agreement (CBA) governing this classification and rate.

Survey Rate Identifiers

Classifications listed under the ""SU"" identifier indicate that no one rate prevailed for this classification in the survey and the published rate is derived by computing a weighted average rate based on all the rates reported in the survey for that classification. As this weighted average rate includes all rates reported in the survey, it may include both union and non-union rates. Example: SULA2012-007 5/13/2014. SU indicates the rates are survey rates based on a weighted average calculation of rates and are not majority rates. LA indicates the State of Louisiana. 2012 is the year of survey on which these classifications and rates are based. The next number, 007 in the example, is an internal number used in producing the wage determination. 5/13/2014 indicates the survey completion date for the classifications and rates under that identifier.

Survey wage rates are not updated and remain in effect until a new survey is conducted.

Union Average Rate Identifiers

Classification(s) listed under the UAVG identifier indicate that no single majority rate prevailed for those classifications; however, 100% of the data reported for the classifications was union data. EXAMPLE: UAVG-OH-0010 08/29/2014. UAVG indicates that the rate is a weighted union average rate. OH indicates the state. The next number, 0010 in the example, is an internal number used in producing the wage determination. 08/29/2014 indicates the survey completion date for the classifications and rates under that identifier.

A UAVG rate will be updated once a year, usually in January of each year, to reflect a weighted average of the current negotiated/CBA rate of the union locals from which the rate is based.

WAGE DETERMINATION APPEALS PROCESS

1.) Has there been an initial decision in the matter? This can be:

- * an existing published wage determination
- * a survey underlying a wage determination
- * a Wage and Hour Division letter setting forth a position on a wage determination matter
- * a conformance (additional classification and rate) ruling

On survey related matters, initial contact, including requests for summaries of surveys, should be with the Wage and Hour National Office because National Office has responsibility for the Davis-Bacon survey program. If the response from this initial contact is not satisfactory, then the process described in 2.) and 3.) should be followed.

With regard to any other matter not yet ripe for the formal process described here, initial contact should be with the Branch of Construction Wage Determinations. Write to:

Branch of Construction Wage Determinations
Wage and Hour Division
U.S. Department of Labor
200 Constitution Avenue, N.W.
Washington, DC 20210

2.) If the answer to the question in 1.) is yes, then an interested party (those affected by the action) can request review and reconsideration from the Wage and Hour Administrator (See 29 CFR Part 1.8 and 29 CFR Part 7). Write to:

Wage and Hour Administrator
U.S. Department of Labor
200 Constitution Avenue, N.W.
Washington, DC 20210

The request should be accompanied by a full statement of the interested party's position and by any information (wage payment data, project description, area practice material, etc.) that the requestor considers relevant to the issue.

3.) If the decision of the Administrator is not favorable, an interested party may appeal directly to the Administrative Review Board (formerly the Wage Appeals Board). Write to:

Administrative Review Board
U.S. Department of Labor
200 Constitution Avenue, N.W.
Washington, DC 20210

4.) All decisions by the Administrative Review Board are final.

=====

END OF GENERAL DECISIO"

APPENDIX F

VENDOR ELIGIBILITY CHECK PRIOR TO CONTRACT AWARD

Appendix G-Vendor Eligibility Check Prior to Contract Award

STATE OF FLORIDA DEPARTMENT OF TRANSPORTATION
Vendor Eligibility Check Prior to Contract Award

375-030-91
PROCUREMENT
06/18

Project Description(s): _____

Financial Project Number(s): _____

In accordance with State law:

Section 287.133(2)(b), Florida Statutes, provides that public entities may not contract with firms that have been excluded from participating in the public contracting process.

A public entity may not accept any bid, proposal, or reply from, award any contract to, or transact any business in excess of the threshold amount provided in s. 287.017, F.S., for CATEGORY TWO with any person or affiliate on the convicted vendor list for a period of 36 months following the date that person or affiliate was placed on the convicted vendor list unless that person or affiliate has been removed from the list pursuant to Section 287.133(3)(f), F.S. A public entity that was transacting business with a person at the time of the commission of a public entity crime resulting in that person being placed on the convicted vendor list may not accept any bid, proposal, or reply from, award any contract to, or transact any business with any other person who is under the same, or substantially the same, control as the person whose name appears on the convicted vendor list so long as that person's name appears on the convicted vendor list.

A contract award (reference 2 CFR 1200 and 2 CFR 180) must not be made to parties listed on the government-wide Excluded Parties List System in the System for Award Management (SAM), in accordance with the OMB guidelines at 2 CFR 180 that implement Executive Orders 12549 (3 CFR Part 1986 Comp., p. 189) and 12689 (3 CFR Part 1989 Comp., p. 235), "Debarment and Suspension." Pursuant to 23 CFR 172.7(b)(3), a contracting agency shall verify suspension and debarment actions and eligibility status of consultants and subconsultants prior to entering into an agreement or contract in accordance with 2 CFR part 1200 and 2 CFR part 180, when the identities of such subconsultants are known prior to execution of the subject agreement or contract. The Excluded Parties List System in SAM contains the names of parties debarred, suspended, or otherwise excluded by agencies, as well as parties declared ineligible under statutory or regulatory authority other than Executive Order 12549.

The Convicted Vendor List/ Suspended Vendor List / Discriminatory Vendor List / Federal Excluded Parties List/ Vendor Complaint Lists are available at the following Department of Management Services site:

http://www.dms.myflorida.com/business_operations/state_purchasing/vendor_information/convicted_suspended_discriminatory_complaints_vendor_lists

Section 287.135, F.S. prohibits a company from bidding on, submitting a proposal for, or entering into or renewing a contract for goods or services of any amount if the company is on the Scrutinized Companies that Boycott Israel List, created pursuant to Section 215.4725, F.S. or is engaged in a boycott of Israel. Section 287.135, F.S. also prohibits a company from bidding on, submitting a proposal for, or entering into or renewing a contract for goods or services of \$1,000,000 or more, if the company is on either the Scrutinized Companies with Activities in Sudan List, or the Scrutinized Companies with Activities in the Iran Petroleum Energy Sector Lists which are created pursuant to s. 215.473, F.S.

STATE OF FLORIDA DEPARTMENT OF TRANSPORTATION
Vendor Eligibility Check Prior to Contract Award

375-030-91
PROCUREMENT
06/18

The List of Scrutinized Companies that Boycott Israel, and the Scrutinized List of Prohibited Companies (Activities in Sudan/Iran Petroleum Energy Sector) are available at the following Florida State Board of Administration site:

<https://www.sbafla.com/fsb/FundsWeManage/FRSPensionPlan/GlobalGovernanceMandates.aspx>

I have checked the aforementioned lists that apply to this procurement, as applicable to verify that the vendor (and all subs where known) is eligible for contract award/execution:

Procurement Office or Contracting Awarding Office:

Printed Name

Signature

Date: _____