

GENERAL CONSTRUCTION NOTES

- A. PROVIDE FILLER PANELS AS REQUIRED AT CASEWORK & MILLWORK INSTALLATION LOCATIONS. TYP. SPECIFICALLY AT LOCATIONS WHERE CASEWORK IS ADJACENT TO WALL. PROVIDE FILLER PANELS FOR EASE OF OPENING & CLOSING CASEWORK DOORS & DRAWERS.
- B. ALL END PANELS SHALL BE FINISHED TO MATCH ADJACENT CABINETS / CASEWORK.
- C. PORCELAIN WALL TILE SHALL ALWAYS BEGIN WITH THE FULL TILE AT THE TOP OF THE ELEVATION. ADJACENT TO THE CEILING, THE CUT TILE SHALL ALWAYS BE AT THE BASE, ADJACENT TO THE FLOOR SURFACE, UNO.
- D. PROVIDE REGULAR CMU BEHIND FLUSH MOUNT FIXTURES AND DEVICES AT LOCATIONS WHERE SPLIT FACE CMU IS CALLED OUT.
- E. WALLS SHALL BE PAINTED PNT-1; UNO.
- F. WALL BASE SHALL BE RWB-1; UNO.
- G. COVE TILE BASE @ LOCKER ROOM(S) TO EXTEND AT LOCKER BASE; TYP.
- H. PROVIDE FILLER PANELS AS REQUIRED @ END(S) OF LOCKER RUN; TYP.
- I. PARGE ALL CMU WALLS AT PORCELAIN TILE INSTALLATION LOCATIONS, AS REQUIRED, FOR A SMOOTH AND CONSISTENT SUBSTRATE.

CONSTRUCTION KEYNOTES

- 1 TYPICAL CASEWORK:
 - FACE AND SIDE FINISH OF BASE AND UPPER CABINETS: PLAM-1
 - INTERIOR FINISH: WHITE MELAMINE
 - IF OPEN SHELF, INTERIOR FINISH SHALL BE PLAM-1
 - COUNTERTOP & 4" SPLASH: PLAM-2
 - HARDWARE PULLS: ADA COMPLIANT, 4" BAR PULL, BRUSHED NICKEL FINISH
- 2 TYPICAL CASEWORK W/ SINK @ BASE CABINET:
 - FACE AND SIDE FINISH OF BASE AND UPPER CABINETS: PLAM-1
 - INTERIOR FINISH: WHITE MELAMINE
 - COUNTERTOP & 4" SPLASH: SSM-1
 - HARDWARE PULLS: ADA COMPLIANT, 4" BAR PULL, BRUSHED NICKEL FINISH
- 3 CASEWORK @ MEDIA CENTER MAKER'S SPACE:
 - FACE AND SIDE FINISH OF BASE AND UPPER CABINETS: PLAM-7
 - INTERIOR FINISH: WHITE MELAMINE
 - COUNTERTOP & 18" BACK-SPLASH: SSM-5
 - HARDWARE PULLS: ADA COMPLIANT, 4" BAR PULL, BRUSHED NICKEL FINISH
- 4 CASEWORK @ MEDIA CENTER KIOSK:
 - FACE AND SIDE FINISH OF BASE CABINETS: PLAM-7
 - INTERIOR FINISH: WHITE MELAMINE
 - COUNTERTOP & 4" BACK-SPLASH: SSM-3
 - HARDWARE PULLS: ADA COMPLIANT, 4" BAR PULL, BRUSHED NICKEL FINISH
- 5 CASEWORK @ SCIENCE ROOMS:
 - FACE AND SIDE FINISH OF UPPER CABINETS: PLAM-6
 - FACE AND SIDE FINISH OF BASE CABINETS: PLAM-6
 - INTERIOR FINISH: WHITE MELAMINE
 - COUNTERTOP & 4" SPLASH: SSM-6
 - HARDWARE PULLS: ADA COMPLIANT, 4" BAR PULL, BRUSHED NICKEL FINISH
- 6 CLASSROOM STORAGE TOWER CASEWORK:
 - FACE AND SIDE FINISH: PLAM-8
 - INTERIOR FINISH: WHITE MELAMINE
 - HARDWARE PULLS: ADA COMPLIANT, 8" BAR PULL, BRUSHED NICKEL FINISH
- 7 Z-CLIP MOUNTED CYM WALL PADDING - REFER TO ARCH. SPECTS FOR FULL DETAILS
- 8 Z-CLIP MOUNTED FULL LENGTH FITNESS MIRRORS - TEMPERED GLASS W/ STAINLESS STEEL U-CHANNEL EDGE @ TOP & BOTTOM (TYP.)
- 9 MILLWORK TEACHING WALL - ALL EXPOSED FACES SHALL BE COVERED WITH VNR-1.
- 10 ACCENT COLOR @ PAINTED GYP. BULKHEAD IN EXTENDED LEARNING AREA, AS WELL AS ABOVE LOCKERS IN THE CORRIDOR. VARIES PER FLOOR:
 - PNT-4 @ LEVEL 1
 - PNT-5 @ LEVEL 2
 - PNT-6 @ LEVEL 3
- 11 CORRIDOR WINDOW MILLWORK SURROUND: ALL PANELS SHALL BE FINISHED IN WOOD VENEER: VNR-1 (REFER TO MATERIAL SCHEDULE & ASSOCIATED ARCHITECTURAL SPECIFICATION). 3 ACCENT PANELS SHALL BE INSTALLED PER LEVEL AS INDICATED:
 - GREEN (PNT-4) LAQUERED PANEL @ L1
 - BLUE (PNT-5) LAQUERED PANEL @ L2
 - ORANGE (PNT-6) LAQUERED PANEL @ L3
- 12 1/4" LAMINATED GLASS (BUTT GLAZED) IN HM FRAME (PNT-19); TYP. @ EXTENDED LEARNING;
- 13 1" INSULATED GLAZING IN AL. STOREFRONT SYSTEM

CASEWORK LEGEND

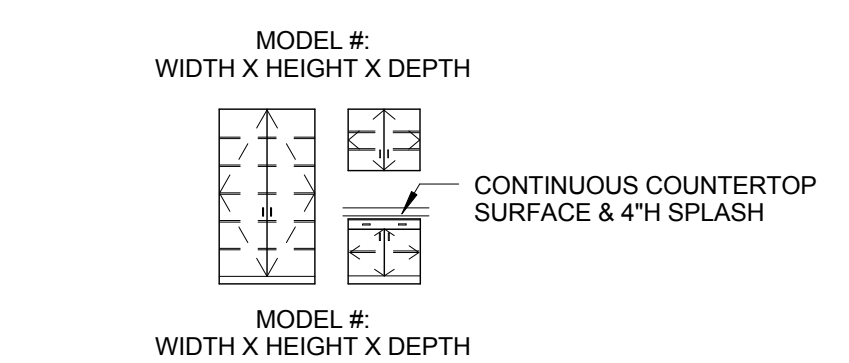

BASIS OF DESIGN: ALL CASEWORK MODEL NUMBERS DESIGNATED ON INTERIOR ELEVATIONS ARE FROM CASE SYSTEMS 2014 PRODUCT OFFERING CATALOG.

REFER TO MATERIAL LEGEND FOR FINISH REQUIREMENTS.

REFER TO SPECIFICATIONS FOR ADDITIONAL ACCEPTABLE MANUFACTURERS.

ACOUSTIC WALL PANEL KEY

- # 1 - 1" WOOD FIBER ACOUSTIC WALL PANELS ON 3-5/8" MTL STUD AT 16" OC WITH ACOUSTICAL INSULATION (GYM)
- # 2 - 2" THICK FABRIC WRAPPED ACOUSTIC PANEL CLIP MOUNTED
 - 2A. HUNTER (APF-2)
 - 2B. MOSS (APF-3)
 - 2C. SPRUCE (APF-4)
 - 2D. MIST (APF-5)
- # 3 - 2" THICK FABRIC WRAPPED BUILT-UP PANEL CLIP MOUNTED (1/2" PLYWOOD ON 2X WOOD BLOCKING)
 - 3A. HUNTER (APF-2)
 - 3B. MOSS (APF-3)
- # 4 - FABRIC WRAPPED ACOUSTIC DIFFUSER
 - 4A. HUNTER (APF-2)
 - 4B. MOSS (APF-3)

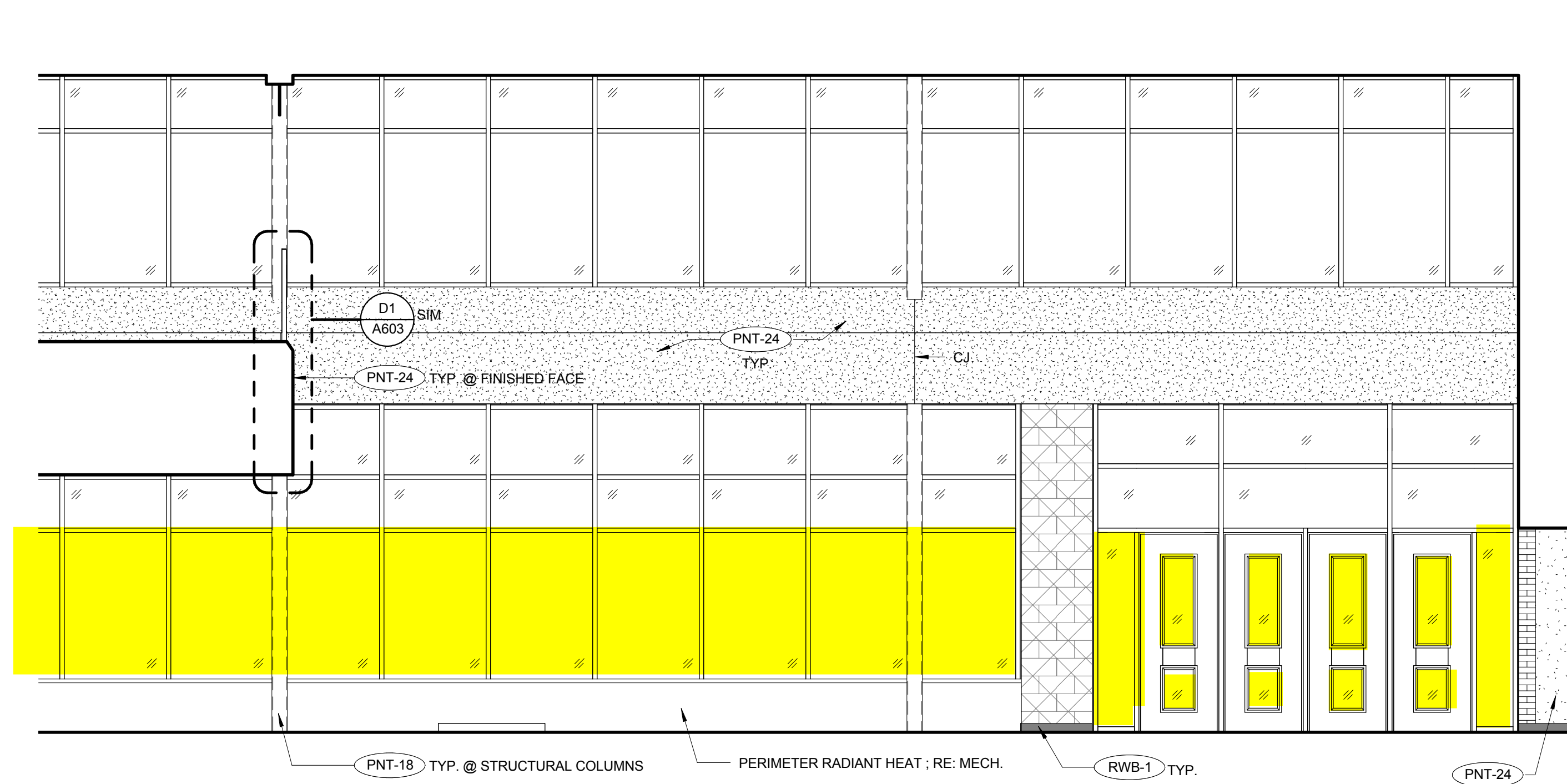

F2 A151 NORTH
1/4" = 1'-0" REFERENCED ON A4 / A111C

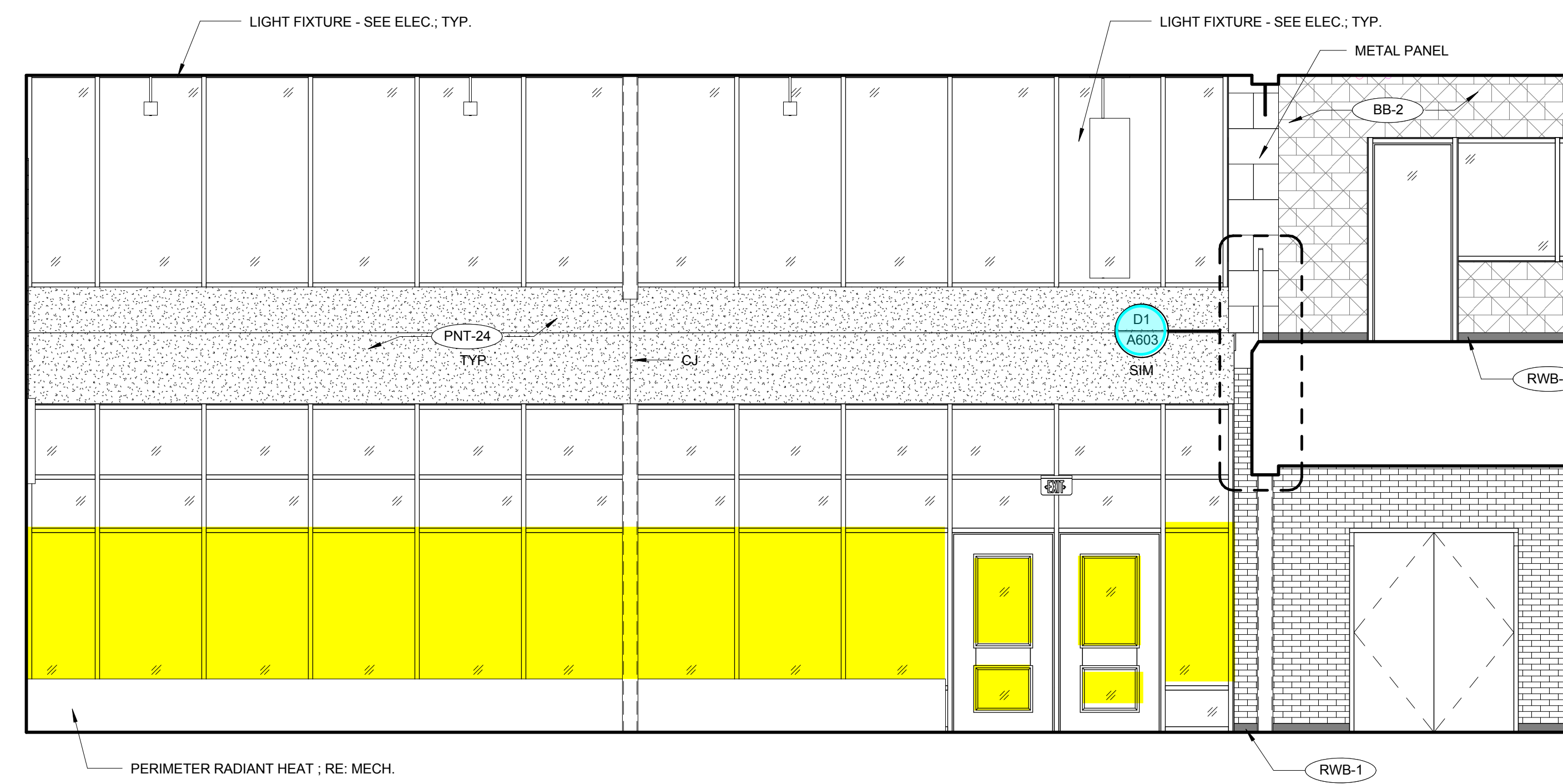

F6 A150 SOUTH
1/4" = 1'-0" REFERENCED ON A4 / A111A

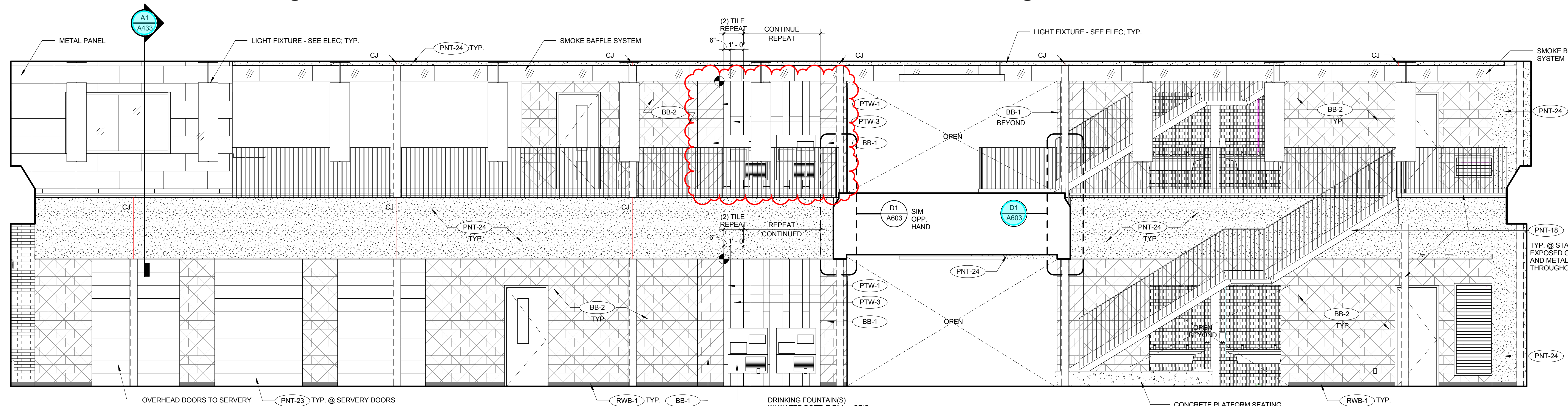

D5 A150 WEST
1/4" = 1'-0" REFERENCED ON A4 / A111A

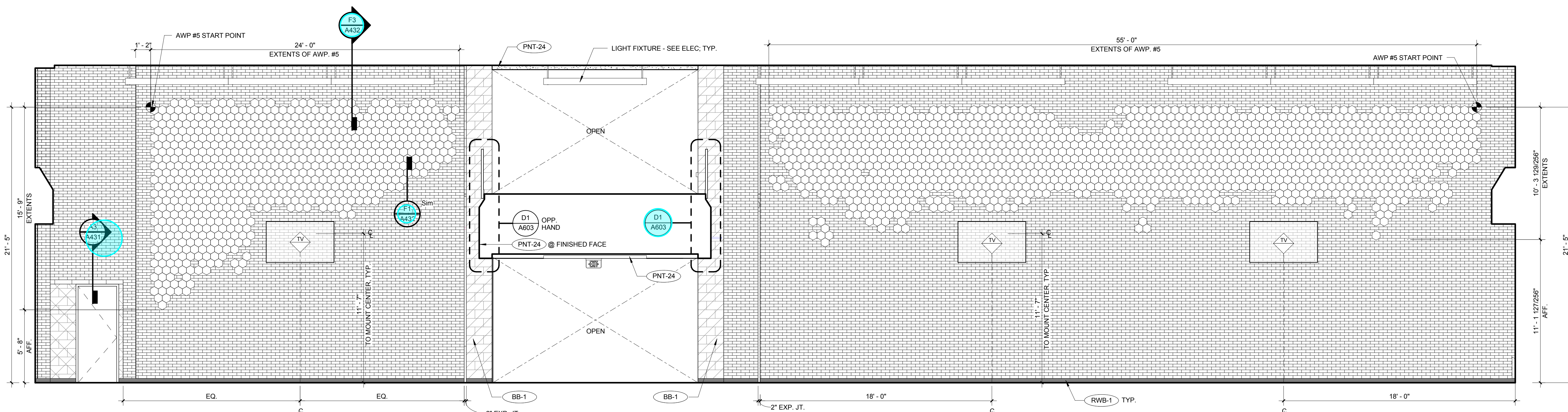

A5 A150 EAST
1/4" = 1'-0" REFERENCED ON A4 / A111A

NOTE: ACOUSTIC WALL PANEL #5 - 1,800 TOTAL

PANELS ARE INSTALLED IN AN ORGANIC INSTALLATION ACROSS THE EXTENT OF THE COMMON AREA. INDIVIDUAL HEX. PANELS SHALL BE PAINTED EITHER PNT-1, 4, 5 OR 6.