

GENERAL CONSTRUCTION NOTES

- A. PROVIDE FILLER PANELS AS REQUIRED AT CASEWORK & MILLWORK INSTALLATION LOCATIONS - TYP. SPECIFICALLY AT LOCATIONS WHERE CASEWORK IS ADJACENT TO WALL - PROVIDE FILLER PANELS FOR EASE OF OPENING & CLOSING CASEWORK DOORS & DRAWERS.
- B. ALL END PANELS SHALL BE FINISHED TO MATCH ADJACENT CABINETRY / CASEWORK.
- C. PORCELAIN WALL TILE SHALL ALWAYS BEGIN WITH THE FULL TILE AT THE TOP OF THE ELEVATION. ADJACENT TO THE CEILING, THE CUT TILE SHALL ALWAYS BE AT THE BASE, ADJACENT TO THE FLOOR SURFACE, UNO.
- D. PROVIDE REGULAR CMU BEHIND FLUSH MOUNT FIXTURES AND DEVICES AT LOCATIONS WHERE SPLIT FACE CMU IS CALLED OUT.
- E. WALLS SHALL BE PAINTED PNT-1; UNO.
- F. WALL BASE SHALL BE RWB-1; UNO.
- G. COVE TILE BASE @ LOCKER ROOM(S) TO EXTEND AT LOCKER BASE, TYP.
- H. PROVIDE FILLER PANELS AS REQUIRED @ END(S) OF LOCKER RUN, TYP.
- I. PARGE ALL CMU WALLS AT PORCELAIN TILE INSTALLATION LOCATIONS, AS REQUIRED, FOR A SMOOTH AND CONSISTENT SUBSTRATE.

CONSTRUCTION KEYNOTES

1. TYPICAL CASEWORK:
 - FACE AND SIDE FINISH OF BASE AND UPPER CABINETRY: PLAM-1
 - INTERIOR FINISH: WHITE MELAMINE
 - IF OPEN SHELF, INTERIOR FINISH SHALL BE PLAM-1
 - COUNTERTOP & 4" SPLASH: PLAM-2
 - HARDWARE PULLS: ADA COMPLIANT, 4" BAR PULL, BRUSHED NICKEL FINISH
2. TYPICAL CASEWORK W/ SINK @ BASE CABINET:
 - FACE AND SIDE FINISH OF BASE AND UPPER CABINETRY: PLAM-1
 - INTERIOR FINISH: WHITE MELAMINE
 - COUNTERTOP & 4" SPLASH: SSM-1
 - HARDWARE PULLS: ADA COMPLIANT, 4" BAR PULL, BRUSHED NICKEL FINISH
3. CASEWORK @ MEDIA CENTER MAKERS SPACE:
 - FACE AND SIDE FINISH OF BASE AND UPPER CABINETRY: PLAM-7
 - INTERIOR FINISH: WHITE MELAMINE
 - COUNTERTOP & 18" BACK-SPLASH: SSM-5
 - HARDWARE PULLS: ADA COMPLIANT, 4" BAR PULL, BRUSHED NICKEL FINISH
4. CASEWORK @ MEDIA CENTER KIOSK:
 - FACE AND SIDE FINISH OF BASE CABINETRY: PLAM-7
 - INTERIOR FINISH: WHITE MELAMINE
 - COUNTERTOP & 4" BACK-SPLASH: SSM-3
 - HARDWARE PULLS: ADA COMPLIANT, 4" BAR PULL, BRUSHED NICKEL FINISH
5. CASEWORK @ SCIENCE ROOMS:
 - FACE & SIDE FINISH OF UPPER CABINETRY: PLAM-7
 - INTERIOR FINISH: WHITE MELAMINE
 - COUNTERTOP & 4" SPLASH: SSM-6
 - HARDWARE PULLS: ADA COMPLIANT, 4" BAR PULL, BRUSHED NICKEL FINISH
6. CLASSROOM STORAGE TOWER CASEWORK:
 - FACE AND SIDE FINISH: PLAM-4
 - INTERIOR FINISH: WHITE MELAMINE
 - HARDWARE PULLS: ADA COMPLIANT, 8" BAR PULL, BRUSHED NICKEL FINISH
7. Z-CLIP MOUNTED GYM WALL PADDING - REFER TO ARCH. SPECS FOR FULL DETAILS
8. Z-CLIP MOUNTED FULL LENGTH FITNESS MIRRORS - TEMPERED GLASS W/ STAINLESS STEEL U-CHANNEL EDGE @ TOP & BOTTOM (TYP)
9. MILLWORK TEACHING WALL - ALL EXPOSED FACES SHALL BE COVERED WITH VNR-1
10. ACCENT COLOR @ PAINTED GYP. BULKHEAD IN EXTENDED LEARNING AREA, AS WELL AS ABOVE LOCKERS IN THE CORRIDOR VARIES PER FLOOR.
 - PNT - 26 @ LEVEL 1
 - PNT - 5 @ LEVEL 2
 - PNT - 6 @ LEVEL 3
11. CORRIDOR WINDOW MILLWORK SURROUND: ALL PANELS SHALL BE FINISHED IN WOOD VENEER, VNR-1 (REFER TO MATERIALS SCHEDULE & ASSOCIATED ARCHITECTURAL SPECIFICATION). 3 ACCENT PANELS SHALL BE INSTALLED PER LEVEL AS INDICATED:
 - GREEN (PNT-4) LAQUERED PANEL @ L1
 - BLUE (PNT-5) LAQUERED PANEL @ L2
 - ORANGE (PNT-6) LAQUERED PANEL @ L3
12. 1/4" LAMINATED GLASS (BUTT GLAZED) IN HM FRAME (PNT-19), TYP. @ EXTENDED LEARNING.
13. 1" INSULATED GLAZING IN AL. STOREFRONT SYSTEM

CASEWORK LEGEND

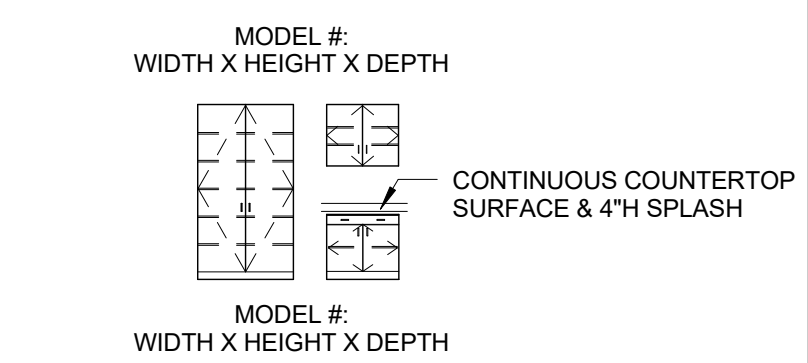

BASIS OF DESIGN: ALL CASEWORK MODEL NUMBERS DESIGNATED ON INTERIOR ELEVATIONS ARE FROM CASE SYSTEMS 2014 PRODUCT OFFERING CATALOG.

REFER TO MATERIAL LEGEND FOR FINISH REQUIREMENTS.

REFER TO SPECIFICATIONS FOR ADDITIONAL ACCEPTABLE MANUFACTURERS.

ACOUSTIC WALL PANEL KEY

- #1 - 1" WOOD FIBER ACOUSTIC WALL PANELS ON 3-5/8" MTL. STUD AT 16" OC WITH ACOUSTICAL INSULATION (GYM)
- #2 - 2" THICK FABRIC WRAPPED ACOUSTIC PANEL CLIP MOUNTED
 - 2A. HUNTER (APF-2)
 - 2B. MOSS (APF-3)
 - 2C. SPRUCE (APF-4)
 - 2D. MIST (APF-5)
- #3 - 2" THICK FABRIC WRAPPED BUILT-UP PANEL CLIP MOUNTED (1/2" PLYWOOD ON 2X WOOD BLOCKING)
 - 3A. HUNTER (APF-2)
 - 3B. MOSS (APF-3)
- #4 - FABRIC WRAPPED ACOUSTIC DIFFUSER
 - 4A. HUNTER (APF-2)
 - 4B. MOSS (APF-3)
- #5 - 1" HEXAGON TECTUM ACOUSTIC PANEL S (COMMON)

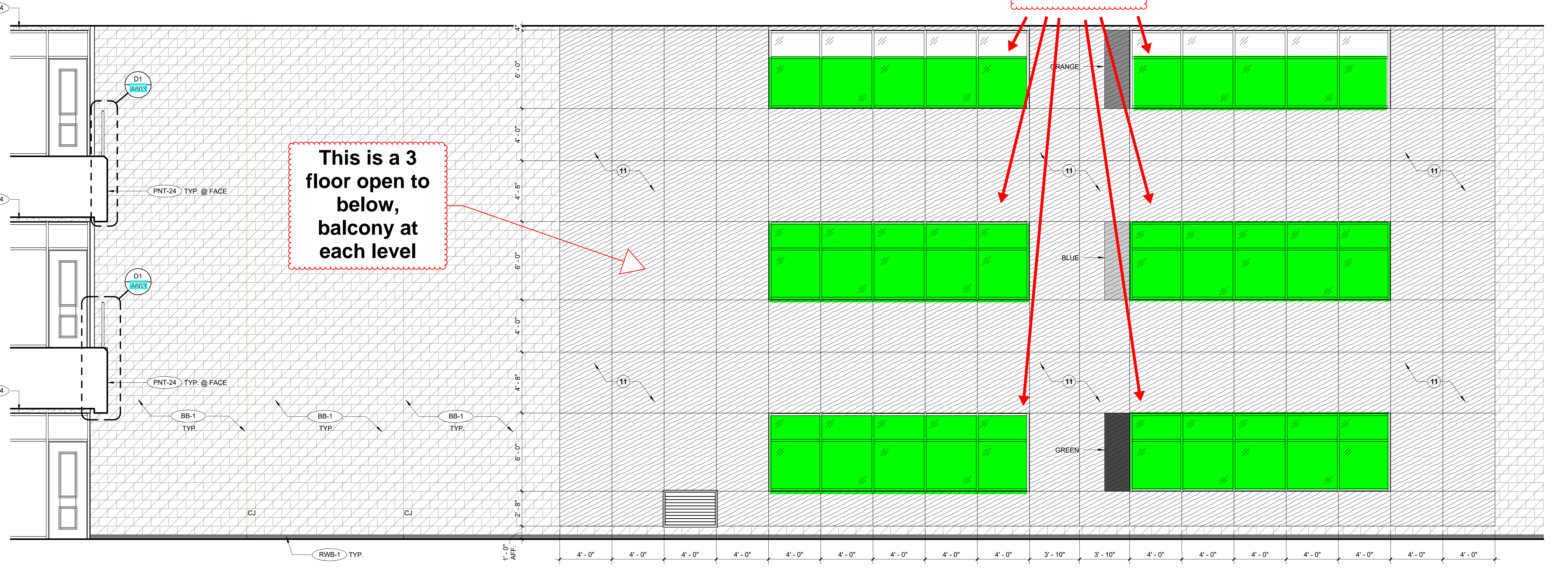
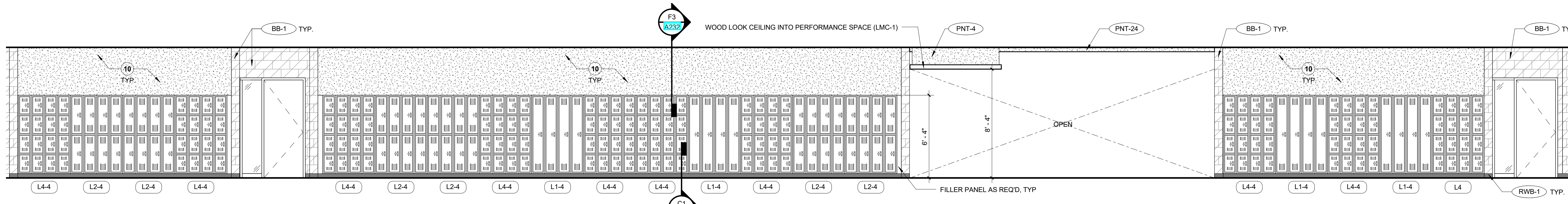
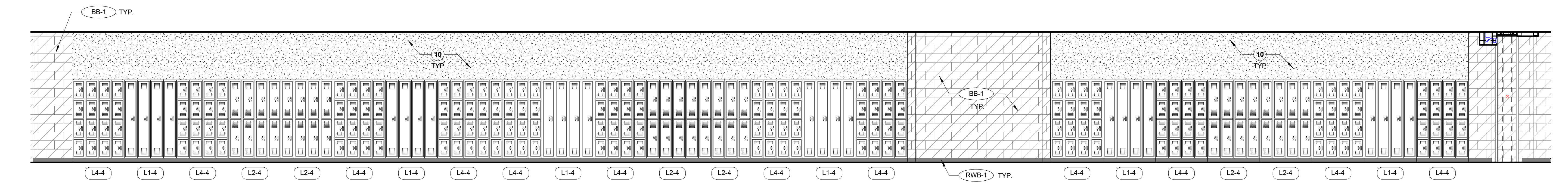
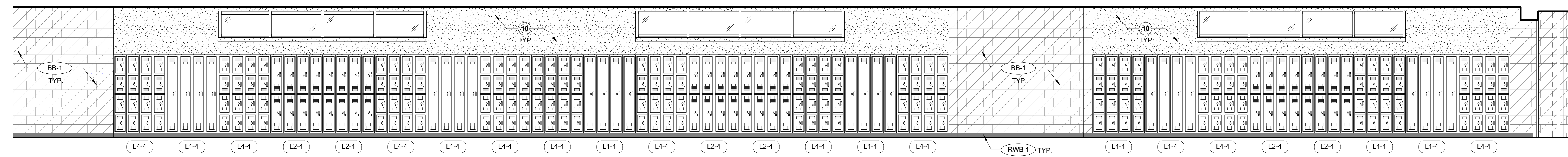

Final Plans for Bidding and Construction

PORTAGE PUBLIC SCHOOLS

Portage Public Schools
THE FUTURE LEARNS HERE

NORTH MIDDLE SCHOOL
PORTAGE, MICHIGAN

DRAWN: Author
CHECKED: Checker
SCALE: As Indicated
UNLESS NOTED OTHERWISE

ISSUE:

2017.03.24	CONSTRUCTION
2017.08.29	PR 02
2018.10.16	PR 13

SHEET TITLE:
INTERIOR ELEVATIONS

A404
Project #: 214100247