

**MORONGO UNIFIED SCHOOL DISTRICT
Business Services
P.O. Box 1209
Twentynine Palms, CA 92277**

BID #19-01

Re-Painting at Three District Sites

**(Condor Elementary School, District Office &
Yucca Mesa Elementary School)**

NOTICE TO VENDORS CALLING FOR BIDS

School District: MORONGO UNIFIED SCHOOL DISTRICT

Bid Deadline: **10:00 A.M. on Wednesday, May 22, 2019**

**Place of Bid Receipt: Business Office Morongo Unified School District
5715 Utah Trail (P O Box 1209), Twentynine Palms, CA 92277**

**Project Identification Name: Bid #19-01 Re-Painting at Three District Sites
(Condor Elementary School, District Office and Yucca Mesa Elementary School**

Place Plans are on File: Purchasing Dept. Morongo Unified School District
5715 Utah Trail, Twentynine Palms, CA 92277

NOTICE IS HEREBY GIVEN that the above-named School District of San Bernardino County, California, acting by and through its Governing Board, hereinafter referred to as "District," will receive up to, but not later than the above-stated time, sealed bids for the above project.

Bids shall be in a sealed envelope marked: Bid #19-01 Re-Painting at Three District Sites

Bids shall be received in the place identified above, and shall be opened and publicly read aloud at the above-stated time and place.

Each bid must conform and be responsive to the bid documents, which are on file for examination at the *Purchasing Department, 5715 Utah Trail, 29 Palms, CA 92277.*

Each bid shall be accompanied by the security referred to in the bid documents and by all documents contained in the provided "Bid Document Package".

The DISTRICT reserves the right to reject any or all bids or to waive any irregularities or informalities in any bids or in the bidding.

The DISTRICT has obtained from the Director of the Department of Industrial Relations the general prevailing rate of per diem wages in the locality in which this work is to be performed for each craft or type of workman needed to execute this contract. Such rates are as on file at the District office, and are available to any interested party on request.

It shall be mandatory upon the CONTRACTOR to whom the contract is awarded, and upon any subcontractor under him, to pay not less than the said specified rates to all workmen employed by them in the execution of the contract.

No bidder may withdraw his bid for a period of 30 (thirty) days after the date set for the opening of bids.

A Payment Bond and a Performance Bond will be required prior to execution of the contract. Both bonds shall be in the form set forth in the contract documents, **and equal to 100% of the Contract amount.**

The Contractor to whom the contract is awarded may avail himself of the provisions of government Code Section 4590, which allows certain securities to be substituted for monies withheld to ensure performance.

SB96 Revised Public Works Contractor Registration Law, as of June 27, 2017: *(which amends the previous SB854 law)*

It revised the previous SB 854 to update the fees to be collected to fund compliance monitoring and enforcement, determine prevailing wage and public works coverage, and hear enforcement appeals.

All contractors and subcontractors intending to bid or perform work on public works projects that meet the requirements for new construction, alteration, installation, demolition or repair that exceed \$25,000.00 for new construction or \$15,000.00 for maintenance, will be required to register, and annually renew, online for the program. The cost to register for the program is currently \$400.00 and is non-refundable. This is a DIR fee paid to the state. The District will not register a contractor, nor collect funds for registration.

No quote or bid can be accepted nor any contract or subcontract entered into nor purchase order issued without proof that the contractor or subcontractor is registered.

If you intend to bid or provide services on District projects in the future, please ensure you are registered with the DIR. The District will require a completed form PWC-100 notifying the DIR of the services you are providing, based on requirements above.

Annual registration fees for public works contractors have increased from \$300 to \$400, and contractors on small projects are exempt from public works registration and electronic certified payroll reporting requirements.

The Labor Commissioner will be able to assess public works contractors' penalties of up to \$8,000 – in addition to any penalty or registration fee – for failure to register. Awarding agencies are also subject to penalties of \$100 a day, up to a maximum of \$10,000, for hiring an unregistered contractor to perform work on a public works project. A contractor that hires an unregistered subcontractor is also subject to penalties of up to \$10,000.

This project is subject to compliance monitoring and enforcement by the DIR Relations. **All contractors must provide a separate form for each of their subcontractors, and they must include a screen shot(s) from the DIR Website for all contractors and subcontractors showing compliance, or your Bid will not be evaluated.**

All project plans and specifications can be found on the Vendor Registry website at:

<https://vrapp.vendorregistry.com/Bids/View/BidsList?BuyerId=f4ef4d91-cf30-465b-bbf1-6839207e31c6>

A **MANDATORY JOB WALK** is scheduled for all interested Contractors on **Friday, May 10, 2019**. Location: Morongo Unified School District, Main Conference Room 5715 Utah Trail, Twentynine Palms, CA 92277. Contact: David Daniels, Director, Maintenance and Operations (760) 367-9191 extension 4231. The walk through will start promptly at **9:00 A.M.** Contractors will be responsible for all measurements as needed.

Bid documents and specifications will be handed out and reviewed at the job walk.

Governing Board

MORONGO UNIFIED SCHOOL DISTRICT

By _____
Sharon Flores
Assistant Superintendent
Business Services

Publish:

April 25 and May 2, 2019 (Hi Desert Start)
April 25 and May 2, 2019 (Desert Trail)

Bid Opening: 10:00 A.M. on Wednesday, May 22, 2019

INFORMATION FOR BIDDERS

1. Preparation of Bid Form. The DISTRICT invites bids on the form attached to be submitted at the time and place stated in the Notice To Contractors Calling For Bids. All blanks in the bid form must be appropriately filled in, and all prices must be stated in both words and figures. All bids must be submitted in sealed envelopes bearing on the outside the name of the bidder, his address, and the name of the project for which the bid is submitted. It is the sole responsibility of the bidder to see that his bid is received in proper time. Any bid received after the scheduled closing time for receipt of bids will be returned to the bidder unopened.

2. Bid Security. Each bid shall be accompanied by cash, a certified check, or a cashier's check payable to the DISTRICT, or a satisfactory bid bond in favor of the DISTRICT, executed by the bidder as principal and a satisfactory surety company as surety, in an amount not less than ten (10)% of the maximum amount of the bid. The bid security shall be given as a guarantee that the bidder shall execute the contract if it be awarded to him in conformity with the contract documents and shall provide the surety bond or bonds as specified within seven (7) days after notification of the award of the contract to the bidder. Said security shall be forfeited to the DISTRICT should the bidder to whom the Contract is awarded fails to execute the Agreement and provide said bonds within seven (7) calendar days of award.

3. Signature. The bid must be signed in the name of the bidder and must bear the signature in longhand of the person or persons duly authorized to sign the bid.

4. Modifications. Changes in or additions to the bid form, recapitulations of the work bid upon, alternative proposals, or any other modification of the bid form which is not specifically called for in the contract documents may result in the DISTRICT'S rejection of the bid as not being responsive to the invitation to bid. No oral or telephonic modification of any bid submitted will be considered and a telegraphic modification may be considered only if the postmark evidences that a confirmation of the telegram duly signed by the bidder was placed in the mail prior to the opening of bids.

5. Erasures. The bid submitted must not contain any erasures, interlineations, or other corrections unless each correction is suitably authenticated by affixing in the margin immediately opposite the correction the signature or signatures of the person or persons signing the bid.

6. Examination of Site and Contract Documents. Each bidder shall visit the site of the proposed work and fully acquaint himself with the conditions relating to the construction and labor so that he may fully understand the facilities, difficulties, and restrictions attending the execution of the work under the contract. Bidders shall thoroughly examine and be familiar with the drawings and specifications. The failure or omission of any bidder to receive or examine any contract documents, form, instrument, addendum, or other document or to visit the site and acquaint himself with conditions there existing shall not relieve any bidder from obligations with respect to his bid or to the contract. The submission of a bid shall be taken as prima facie evidence of compliance with this section.

7. Withdrawal of Bids. Any bidder may withdraw his bid either personally, by written request, or by telegraphic request confirmed in the manner specified above at any time prior to the scheduled closing time for receipt of bids.

8. Agreements and Bonds. The Agreement form which the successful bidder, as Contractor, will be required to execute, and the form of the payment bond which he will be required to furnish in accordance with Civil Code Section 3246 prior to execution of the Agreement, are included in the contract documents and should be carefully examined by the bidder. The payment bond shall be in the amount of one hundred (100)% of the contract. The contractor will also be required to furnish a performance bond in the amount of one hundred (100)% of the amount of the contract prior to execution of the contract.

9. Interpretation of Plans and Documents. If any person is in doubt as to the true meaning of any part of the contract documents, or finds discrepancies in, or omissions from the drawings and specifications, he may submit to the DISTRICT a written request for an interpretation or correction thereof. The person submitting the request shall be responsible for its prompt delivery. Any interpretation or correction of the contract documents will be made only by addendum duly issued and a copy of such addendum will be mailed or delivered to each person receiving a set of the contract documents. No oral interpretation of any provision in the contract documents will be made to any bidder.

10. Bidders Interested In More Than One Bid. No person, firm or corporation shall be allowed to make, or file, or be interested in more than one bid for the same work unless alternate bids are specifically called for. A person, firm or corporation that has submitted a subproposal to a bidder, or that has quoted prices of materials to a bidder, is not thereby disqualified from submitting a proposal or quoting prices to other bidders or making a prime proposal.

11. Award of Contract. The DISTRICT reserves the right to reject any or all bids, or to waive any irregularities or informalities in any bids or in the bidding. The award of the contract, if made by the DISTRICT, will be to the lowest responsible bidder therefor.

12. Alternates. If alternate bids are called for, the contract may be awarded at the election of the governing board to the lowest responsible bidder on the base bid, or on the base bid and any alternate or combination of alternates.

13. Evidence of Responsibility. Upon the request of the DISTRICT, a bidder whose bid is under consideration for the award of the contract shall submit promptly to the DISTRICT satisfactory evidence showing the bidder's financial resources, his construction experience, and his organization available for the performance of the contract.

14. Listing Subcontractors. Each bidder shall submit a list of the proposed subcontractors on this project as required by the Subletting and Subcontracting Fair Practices Act (Govt. Code Sec. 4100 et seq.). Forms for this purpose are furnished with the contract documents.

15. Workmen's Compensation. In accordance with the provisions of Section 3700 of the Labor Code, Contractor shall secure the payment of compensation to his employees. Contractor shall sign and file with DISTRICT the following certificate prior to performing the work under this contract: "I am aware of the provisions of Section 3700 of the Labor Code which require every employer to be insured against liability for workmen's compensation or to undertake self-insurance in accordance with the provisions of that code, and I will comply with such provisions before commencing the performance of the work of this contract." The form of such certificate is included as a part of the contract documents.

The Contractor shall provide, during the life of this contract, workers' compensation insurance for all its employees engaged in work under this contract, or at the site of the project, and if work is sublet, the Contractor shall require the subcontractor similarly to provide workers' compensation insurance for all the latter's employees. Contractor must provide a Certificate of Insurance indicating "statutory" limits. 30-day notice of intent to cancel, non-renew, or make material change in coverage prior to commencement of the project. Employer's Liability, \$2,000,000 per accident for bodily injury or disease. Any class of employee or employees not covered by a subcontractor's insurance shall be covered by the Contractor's insurance.

16. Certification of Bidder and Qualifications. In order for the District to determine the successful bidder, the bidder shall submit, in writing, at the time he/she submits his/her bid:

- a. A completed Certification of Bidder and Qualifications form. The form is furnished with the contract documents. Failure to successfully complete this form may be cause for rejection of the bid.
- b. Proof on the Certification of Bidder and Qualifications form that the bidder has been in business under the same license and company name for at least five consecutive years and shall have successfully completed at least three similar both dollar amount and scope of work, projects to those being bid.

17. **SB 854 & SB 96 – Important Information for Contractors**

SB 854 (Stat. 2014, chapter 28) made several changes to the laws governing how the Department of Industrial Relations (DIR) monitors compliance with prevailing wage requirements on public works projects & SB 96 established amount thresholds as follows:

- a) No contractor or subcontractor may be listed on a bid proposal for a public works project (submitted on or after March 1, 2015) unless registered with the Department of Industrial Relations pursuant to Labor Code section 1725.5 [with limited exceptions from this requirement for bid purposes only under Labor Code section 1771.1(a)]No contractor or subcontractor may be awarded a contract for public work on a public works project (awarded on or after April 1, 2015) unless registered with the Department of Industrial Relations pursuant to Labor Code section 1725.5.
- b) This project is subject to compliance monitoring and enforcement by the Department of Industrial Relations.
- c) The prime contractor must post job site notices prescribed by regulation. (See 8 Calif. Code Reg. §16451(d) for the notice that previously was required for projects monitored by the CMU (Compliance Monitoring Unit).)
- d) Those who fail to register and maintain their status as a public works contractor shall not be permitted to perform work on the project.

18. A **MANDATORY JOB WALK** is scheduled for all interested Contractors on **Friday, May 10, 2019**. Location: Morongo Unified School District Offices, Main Conference Room, 5715 Utah Trail, Twentynine Palms, CA 92277. Contact David Daniels, Director of Maintenance and Operations, (760) 367-9191, ext. 4231. The walk-through will start promptly at **9:00 A.M.** **Contractors will be responsible for all measurements as needed.** Access to the job site on any other date will not be permitted unless prior arrangements have been made by contacting Mr. Daniels at the number listed above.

19. **In order to gain access to Condor Elementary School, you will be required to enter through the Twentynine Palms Marine Base main entrance gate and have to abide by their access requirements.** For any contractors/sub-contractors who do not currently have a base access I.D., in order for the District to request base access for the **MANDATORY JOB WALK**, you will be required to have a **“Real California I.D.”** per the “Real California I.D. Act. The **AWARDED CONTRACTOR** will be responsible for each of their employees to have all necessary documentation to have access to enter the Twentynine Palms Marine Base.

BID FORM

TO: Morongo Unified School District acting by and through its Governing Board, herein called the "DISTRICT":

Pursuant to and in compliance with your Notice to Contractors Calling for Bids and the other documents relating thereto, the undersigned bidder, having familiarized himself with the terms of the Contract, the local conditions affecting the performance of the Contract and the cost of the work at the place where the work is to be done, and with the Drawings and Specifications and other contract documents, hereby proposes and agrees to perform, within the time stipulated, the Contract, including all of its component parts, and everything required to be performed, and to provide and furnish any and all of the labor, materials, tools, expendable equipment, and all applicable taxes, utility and transportation services necessary to perform the Contract and complete in a workmanlike manner all of the work required in connection with:

Bid #19-01

Re-Painting at Three District Sites

(Condor Elementary School, District Office and Yucca Mesa Elementary School)

all in strict conformity with the Drawings and Specifications and other contract documents, including Addenda Nos. _____, _____, on file at the District Office of the Morongo Unified School District.

This bid is for a total base bid of _____

(\$ _____) including all applicable taxes, permits and licenses.

Base Bid by site as follows:

Condor Elementary School	_____	(\$ _____)
District Office	_____	(\$ _____)
Yucca Mesa Elementary School	_____	(\$ _____)

Bid award will be to one contractor for all locations. Individual pricing is necessary for District accounting purposes.

TIME TO COMPLETE PROJECT:

The work shall be commenced on Monday, July 1, 2019 and shall be completed prior to Friday, August 16, 2019. Award of bid/contract shall be on Tuesday, May 28, 2019.

ACCOMPANYING THIS PROPOSAL IS _____ (Insert the words "Cash,"
"Bidder's Bond," or "Certified Check" as the case may be) in the amount equal to at least ten percent [10%] of the total
bid, payable to the Morongo Unified School District.

Respectfully Submitted: _____

Name of Bidder: _____

Type of Organization: _____

Signed by: _____

Title of Signer: _____

Address of Bidder: _____

Telephone Number: _____

Contractor's License Number: _____

BID BOND

KNOW ALL MEN BY THESE PRESENT, that we, the undersigned, _____
_____ as Principal,
and _____
as Surety, are hereby held and firmly bound unto the _____
_____ hereinafter called the "Owner," in
the sum of _____
_____ DOLLARS (\$ _____)

WHEREAS, the said Principal is hereby submitting its proposal for _____

THE CONDITION OF THE ABOVE OBLIGATION IS SUCH, that if the aforesaid Principal shall be awarded the contract upon said Proposal and shall, within the required number of days after the notice of such award, execute a written memorial of the awarded contract and submit the required labor and material and faithful performance bonds, then this obligation shall be null and void; and in the event that the Principal fails and/or refuses to execute and deliver said documents this bond will be charged with the costs of the damages experienced by the Owner as a result of such refusal, including but not limited to, publication costs, the difference in money between the amount of the bid of the said Principal and the amount for which the obligee may legally contract with another party to perform the said work if such amount be in excess of the former; building lease or rental costs, transportation costs, and additional salary costs that result from the delay due to the Principal's default on the awarded contract. In no event, however, shall the Surety's liability exceed the penal sum hereof.

The Surety, for value received, hereby stipulates and agrees that the obligations of said Surety and its bond shall be in no way impaired or affected by any extension of the time within which the Owner may accept such bid; and said Surety does hereby waive notice of any such extension.

IN WITNESS WHEREOF, the above-bounden parties have executed this instrument under their several seals this _____ day of _____, 2019, and the name and corporate seal of each corporate party being hereto affixed and these presents duly signed by its undersigned representative, pursuant to authority of its governing body.

In presence of

(Individual Principal) (Seal)

(Address) (Business Address)

(Individual Principal) (Seal)

(Business Address)

Attest:

(Corporate Principal)

(Business Address)

By _____ (Affix
Corporate Seal)

Attest:

(Corporate Surety)

(Business Address)

By _____ (Affix
Surety Seal)

The rate of premium on this bond is _____ per thousand.

Total amount of premium charges, \$ _____.

(The above must be filled in by corporate surety)

DEVIATIONS FORM

Any and all DEVIATIONS to this Bid Package including specifications or equipment and methods of installation are noted below. Anything not here noted is to be considered “as per specifications”.

Signature _____ Date _____

Company _____

*(This form **MUST** be submitted with your Bid Package)*

DESIGNATION OF SUBCONTRACTORS

In compliance with the Subletting and Subcontracting Fair Practices Act (Chapter 2, commencing at Section 4100, Division 5, Title 1 of the Government Code of the State of California) and any amendments thereof, each bidder shall set forth below: (a) the name and the location of the place of business of each subcontractor who will perform work or labor or render service to the prime contractor in or about the construction of the work or improvement to be performed under this contract, or a subcontractor licensed by the State of California who, under subcontract to the prime contractor, specially fabricates and installs a portion of the work improvement according to detailed drawings contained in the plans and specifications, in an amount in excess of one-half of one percent of the prime contractor's total bid and (b) the portion of the work which will be done by each subcontractor under this act. The prime contractor shall list only one subcontractor for each such portion as is defined by the prime contractor in this bid.

If a prime contractor fails to specify a subcontractor or if a prime contractor specifies more than one subcontractor for the same portion of work to be performed under the contract in excess of one-half of one percent of the prime contractor's total bid, he shall be deemed to have agreed that he is fully qualified to perform that portion himself, and that he shall perform that portion himself.

No prime contractor whose bid is accepted shall (a) substitute any subcontractor, (b) permit any subcontract to be voluntarily assigned or transferred or allow it to be performed by anyone other than the original subcontractor listed in the original bid, or (c) sublet or subcontract any portion of the work in excess of one-half of one percent of the prime contractor's total bid as to which his original bid did not designate a subcontractor, except as authorized in the Subletting and Subcontracting Fair Practices Act. Subletting or subcontracting of any portion of the work in excess of one-half of one percent of the prime contractor's total bid as to which no subcontractor was designated in the original bid shall only be permitted in cases of public emergency or necessity and then only after a finding reduced to writing as a public record of the authority awarding this contract setting forth the facts constituting the emergency or necessity.

Work to be done by Subcontractor	Subcontractor	Location of Business	CSLB Contractor License #	DIR Registration Number

Work to be done by Subcontractor	Subcontractor	Location of Business	CSLB Contractor License #	DIR Registration Number

Respectfully Submitted:

Name of Bidder:

Type of Organization: _____

Signed by: _____

Title of Signer: _____

Address of Bidder: _____

Telephone Number: _____

Contractor's License Number: _____

If the Bidder is a corporation, and signer is not President or Secretary, attach certified copy of By-Laws or Resolution authorizing execution. If bidder is a corporation affix corporate seal. If signer is an agent attach power of attorney. If bidder is not an individual, list names of other persons authorized to bond the organization.

Revised Public Works Contractor Registration Law (SB 96)

(Signed into law June 28, 2017, became effective immediately)

It revised the previous SB 854 to update the fees to be collected to fund compliance monitoring and enforcement, determine prevailing wage and public works coverage, and hear enforcement appeals.

All contractors and subcontractors intending to bid or perform work on public works projects that meet the requirements for new construction, alteration, installation, demolition or repair that exceed \$25,000.00 for new construction or \$15,000.00 for maintenance, will be required to register, and annually renew, online for the program. The cost to register for the program is currently \$400.00 and is non-refundable. This is a DIR fee paid to the state. The District will not register a contractor, nor collect funds for registration.

No quote can be accepted nor any contract or subcontract entered into nor purchase order issued without proof that the contractor or subcontractor is registered.

If you intend to bid or provide services on District projects in the future, please ensure you are registered with the DIR. The District will be required to complete a form PWC-100 notifying the DIR of the services you are providing, based on requirements above.

See Attachment "A" for the information required on the PWC-100 form. This information must be included in all quotes and/or bids, and must also be included for any subcontractor you use (they must also be registered with DIR). The District will not issue a Purchase Order without the completed PWC-100 form.

Attachment "A"

PWC-100 Information

FORM MUST BE RETURNED WITH BID

CONTRACTOR'S INFORMATION REQUIRED

****MUST BE COMPLETED FOR ALL CONTRACTORS AND SUB-CONTRACTORS****

Contractor's Name and Address _____

Contractor's Telephone Number _____

Email Address _____

Contractor's License Number _____

Registration Number given by DIR _____

Project Name _____

Project Description _____

Project Cost _____

Estimated Start Date _____

Estimated Completion Date _____

Project Superintendent Name _____

Classification, (please select one)

- | | | | |
|--|--|---|--|
| <input type="checkbox"/> Asbestos | <input type="checkbox"/> Boilermaker | <input type="checkbox"/> Bricklayers | <input type="checkbox"/> Carpenters |
| <input type="checkbox"/> Carpet/Linoleum | <input type="checkbox"/> Cement Masons | <input type="checkbox"/> Drywall Finisher | <input type="checkbox"/> Drywall/Lathers |
| <input type="checkbox"/> Electricians | <input type="checkbox"/> Elevator Mechanic | <input type="checkbox"/> Glaziers | <input type="checkbox"/> Iron Workers |
| <input type="checkbox"/> Laborers | <input type="checkbox"/> Mill Wrights | <input type="checkbox"/> Operating Eng | <input type="checkbox"/> Painters |
| <input type="checkbox"/> Pile Drivers | <input type="checkbox"/> Pipe Trades | <input type="checkbox"/> Plasterers | <input type="checkbox"/> Roofers |
| <input type="checkbox"/> Sheet Metal | <input type="checkbox"/> Sound/Comm | <input type="checkbox"/> Surveyors | <input type="checkbox"/> Teamster |
| <input type="checkbox"/> Tile Workers | | | |

**CONTRACTOR'S CERTIFICATE
REGARDING WORKMEN'S COMPENSATION**

Labor Code Section 3700

"Every employer except the State and all political subdivisions or institutions thereof, shall secure the payment of compensation in one or more of the following ways:

(a) By being insured against liability to pay compensation in one or more insurers duly authorized to write compensation insurance in this State.

(b) By securing from the Director of Industrial Relations a certificate of consent to self-insure, which may be given upon furnishing proof satisfactory to the Director of Industrial Relations of ability to self-insure and to pay any compensation that may become due to his employees."

I am aware of the provisions of Section 3700 of the Labor Code which require every employer to be insured against liability for workmen's compensation or to undertake self-insurance in accordance with the provisions of that code, and I will comply with such provisions before commencing the performance of the work of this contract.

(In accordance with Article 5 [commencing at Section 1860], Chapter 1, Part 7, Division 2 of the Labor code, the above certificate must be signed and filed with the awarding body prior to performing any work under this contract.)

**NONCOLLUSION DECLARATION TO BE EXECUTED
BY BIDDER AND SUBMITTED WITH BID**

(Public Contract Code Section 7106)

The undersigned declares:

I am the _____ of _____, the party making the foregoing bid.

The bid is not made in the interest of, or on behalf of, any undisclosed person, partnership, company, association, organization, or corporation. The bid is genuine and not collusive or sham. The bidder has not directly or indirectly induced or solicited any other bidder to put in a false or sham bid. The bidder has not directly or indirectly colluded, conspired, connived, or agreed with any bidder or anyone else to put in a sham bid, or to refrain from bidding. The bidder has not in any manner, directly or indirectly, sought by agreement, communication, or conference with anyone to fix the bid price of the bidder or any other bidder, or to fix any overhead, profit, or cost element of the bid price, or of that of any other bidder. All statements contained in the bid are true. The bidder has not, directly or indirectly, submitted his or her bid price or any breakdown thereof, or the contents thereof, or divulged information or data relative thereto, to any corporation, partnership, company, association, organization, bid depository, or to any member or agent thereof, to effectuate a collusive or sham bid, and has not paid, and will not pay, any person or entity for such purpose.

Any person executing this declaration on behalf of a bidder that is a corporation, partnership, joint venture, limited liability company, limited liability partnership, or any other entity, hereby represents that he or she has full power to execute, and does execute, this declaration on behalf of the bidder.

I declare under penalty of perjury under the laws of the State of California that the foregoing is true and correct and that this declaration is executed on _____[date], at _____[city], _____[state].

Signature

Print Name

SITE VISIT CERTIFICATION

I certify that I have visited the site of the proposed work and have fully aquatinted myself with the conditions relating to construction and labor. I fully understand the facilities, difficulties, and restrictions attending the execution of the work under contract.

I certify under penalty of perjury under the laws of the State of California that the foregoing is true and correct.

I fully indemnify **DISTRICT**, the Architect, and all of their respective officers, agents, employees, and consultants from any damage, or omissions, related to conditions that could have been identified during my visit to the site.

(Signature of Bidder)

(Type Name of Bidder)

SUBSCRIBED BEFORE ME on this _____ day of _____, **2019**

(Notary Public)

My commission expires: _____

CERTIFICATION OF BIDDER AND QUALIFICATIONS

The undersigned bidder certifies that he or she is, at the time of bidding, and shall be throughout the period of the contract, licensed by the State of California to do the type of work required under the terms of the contract documents. Bidder further certifies that he or she is skilled and regularly engaged in the general class and type of work called for in the contract documents.

The bidder represents that he or she is competent, knowledgeable and has special skills with respect to the nature, extent and inherent conditions of the work to be performed. Bidder further acknowledges that there are certain peculiar and inherent conditions existent in the construction of the work which may create, during the work, unusual or peculiar unsafe conditions hazardous to persons and property.

Bidder expressly acknowledges that he or she is aware of such peculiar risks and that he or she has the skill and experience to foresee and to adopt protective measures to adequately and safely perform the construction work with respect to such hazards.

Furthermore, bidder hereby certifies to the District that all representations, certifications and statements made by bidder, as set forth in this bid form, are true and correct and are made under penalty of perjury.

Signed this _____ day of _____, 2019

Name of Bidder

Contractor's License No.

Contractor's License Expiration Date

Signature of Bidder

Title of Signator

**CRIMINAL BACKGROUND INVESTIGATION
CERTIFICATION (Contractor)**

Morongo Unified School District

The undersigned does hereby certify to the governing board of the School District ("District") as follows:

1. That I am a representative of _____ ("Contractor"), currently under contract ("Contract") with the District; that I am familiar with the facts herein certified and am authorized and qualified to execute this certificate on behalf of Contractor.

2. That Contractor has complied with the fingerprinting and criminal background investigation requirements of California Education Code section 45125.1 with respect to all Contractor's employees who may have contact with District pupils in the course of providing services pursuant to the Contract, and that the California Department of Justice has determined that none of those employees has been convicted of a felony, as that term is defined in Education Code section 45122.1.

3. That a complete and accurate list of Contractor's employees who may come in contact with District pupils during the course and scope of the Contract shall be provided upon award of bid.

Dated: _____

CONTRACTOR

By: _____

Title: _____

MORONGO UNIFIED SCHOOL DISTRICT
5715 UTAH TRAIL
29 PALMS, CA 92277

HOLD HARMLESS

CONSULTANT hereby agrees to indemnify, defend, save and hold harmless the MORONGO UNIFIED SCHOOL DISTRICT and the CALIFORNIA SCHOOLS RISK MANAGEMENT – JPA, its departments, agencies, officers or employees from and against any and all liability, loss, expense including reasonable attorney fees, or claims for injury or damages arising out of the performance of the services rendered by CONSULTANT whether caused by any error, omission or act of CONSULTANT or any person employed by him or her or by the District. Said sums shall include, in the event of legal action, court costs, expenses of litigation and reasonable attorney's fees.

Date _____

Consultant Signature

Please Print Name

**MORONGO UNIFIED SCHOOL DISTRICT
DRUG-FREE WORKPLACE CERTIFICATION**

State and certify to all of the following:

1. I am aware of the provisions and requirements of California Government Code § 8350 et seq., the Drug Free Workplace Act of 1990.
2. I am authorized to certify, and do certify, on behalf of Contractor that a drug free workplace will be provided by Contractor by doing all of the following:
 - A. Publishing a statement notifying employees that the unlawful manufacture, distribution, dispensation, possession or use of a controlled substance is prohibited in Contractor's workplace and specifying actions that will be taken against employees for violation of the prohibition;
 - B. Establishing a drug-free awareness program to inform employees about all of the following:
 - (i) The dangers of drug abuse in the workplace;
 - (ii) Contractor's policy of maintaining a drug-free workplace;
 - (iii) The availability of drug counseling, rehabilitation and employee-assistance programs; and
 - (iv) The penalties that may be imposed upon employees for drug abuse violations;
 - C. Requiring that each employee engaged in the performance of the Contract be given a copy of the statement required by subdivision (A), above, and that as a condition of employment by Contractor in connection with the Work of the Contract, the employee agrees to abide by the terms of the statement.
3. Contractor agrees to fulfill and discharge all of Contractor's obligations under the terms and requirements of California Government Code §8355 by, inter alia, publishing a statement notifying employees concerning: (a) the prohibition of any controlled substance in the workplace, (b) establishing a drug-free awareness program, and (c) requiring that each employee engaged in the performance of the Work of the Contract be given a copy of the statement required by California Government Code §8355(a) and requiring that the employee agree to abide by the terms of that statement.
4. Contractor and I understand that if the District determines that Contractor has either: (a) made a false certification herein, or (b) violated this certification by failing to carry out and to implement the requirements of California Government Code §8355, the Contract awarded herein is subject to termination, suspension of payments, or both. Contractor and I further understand that, should Contractor violate the terms of the Drug-Free Workplace Act of 1990, Contractor may be subject to debarment in accordance with the provisions of California Government Code §8350, et seq.
5. Contractor and I acknowledge that Contractor and I are aware of the provisions of California Government Code §8350, et seq. and hereby certify that Contractor and I will adhere to, fulfill, satisfy and discharge all provisions of and obligations under the Drug-Free Workplace Act of 1990.

Name of Company

Authorized Signature

Print

Title

Contract Documents

BID #19-01

Re-Painting at Three District Sites

**(Condor Elementary School, District Office &
Yucca Mesa Elementary School)**

AGREEMENT

THIS AGREEMENT, dated _____ day of _____, 2019, in the County of San Bernardino, State of California, by and between **MORONGO UNIFIED SCHOOL DISTRICT**, hereinafter referred to as "DISTRICT," and _____ (*name of contractor*), hereinafter referred to as "CONTRACTOR,"

W I T N E S S E T H:

That the DISTRICT and the CONTRACTOR, for the consideration stated herein, agree as follows:

1. The complete contract includes all of the contract documents, including the Notice to Contractors Calling for Bids, Information for Bidders, Bid Form, Deviations Form, Bid Bond, Designation of Sub-Contractors, Contractor's Certifications of Workers Compensation, Non-Collusion Declaration, Site Visitation Certification, Certification of Bidder and Qualifications, Criminal Background Investigation Certification, Plans, Drawings, Specifications, General Conditions and any addenda thereto, the Agreement, Payment and Performance Bonds, Supplementary General Conditions and all modifications and amendments thereto. The contract documents are complementary, and what is called for by any one shall be as binding as if called for by all.

2. CONTRACTOR shall perform everything required to be performed, and shall provide and furnish all the labor, materials, necessary tools, expendable equipment, and all utility and transportation services required for the completion of the work associated to:

Bid # 19-01 Re-Painting at Three District Sites

All of said work to be performed and materials to be furnished shall be in strict accordance with the Plans, Drawings, Specifications and provisions of the contract hereinabove enumerated.

3. DISTRICT shall pay to the CONTRACTOR, as full consideration for the faithful performance of the contract, subject to any additions or deductions as provided in the contract documents, the sum of

(\$ _____)

4. The work shall be commenced on **Monday, July 1, 2019** and shall be completed by no later than **Friday, August 16, 2019** Award of bid/contract shall be on **Tuesday, May 29, 2019**.

5. The acceptance by the CONTRACTOR of the final payment shall constitute a waiver of all claims against the DISTRICT under or arising out of this contract.

6. Time is of the essence, and CONTRACTOR agrees to forfeit and pay to DISTRICT **\$250.00 (two hundred fifty dollars)** per project site for each calendar day completion of work is delayed beyond the specified day of completion.

7. CONTRACTOR shall take out and maintain during the life of this contract insurance as required by Article 20 through 23 of the General Conditions in the following amounts:

I. General Liability:

- A. Commercial General Liability with \$1,000,000 per occurrence for Bodily Injury, Personal and Advertising Injury and Property Damage including Blanket Contractual Liability, Products Liability, Completed Operations. Sexual Abuse or Molestation Injury Limit of \$2,000,000.
- B. Contractor's insurance to be primary and non-contributory.
- C. 30-Day notice of intent to cancel, non-renew, or make material change in coverage. Morongo Unified School District and CSRJ JPA to be named as "Additional Insured."
- D. Executed Indemnity and Hold Harmless Agreement or substantially similar provisions should be included in the bid specifications or contract.

II. Automobile Liability:

- A. \$1,000,000 Combined Single Limit for Bodily Injury and Property Damage per accident.
- B. Coverage to include "Owned, Non-Owned, and Hired" automobiles.
- C. 30-Day notice of intent to cancel, non-renew, or make material change in coverage.

III. Workers' Compensation/Employer's Liability:

- A. Certificate of Insurance indicating "statutory" limits.
- B. 30-Day notice of intent to cancel, non-renew, or make material change in coverage.
- C. Employer's Liability, \$1,000,000 per accident for bodily injury or disease.

8. CONTRACTOR hereby agrees to indemnify, defend, save and hold harmless the MORONGO UNIFIED SCHOOL DISTRICT and the CALIFORNIA SCHOOLS RISK MANAGEMENT – JPA, its departments, agencies, officers or employees from and against any and all liability, loss, expense including reasonable attorney fees, or claims for injury or damages arising out of the performance of the services rendered by CONTRACTOR whether caused by any error, omission or act of CONTRACTOR or any person employed by him or her or by the District. Said sums shall include, in the event of legal action, court costs, expenses of litigation and reasonable attorney's fees.

IN WITNESS WHEREOF, the parties hereto have caused this Agreement to be executed.

By _____ By _____
"DISTRICT" "CONTRACTOR"

Contractor's License No. _____

CORPORATE SEAL

PERFORMANCE BOND

100% OF CONTRACT AMOUNT

WHEREAS, the **MORONGO UNIFIED SCHOOL DISTRICT** by Board action on _____, 2019, has awarded to _____

hereinafter designated as the "Principal," a contract for the work described as follows:

WHEREAS, said Principal is required under the terms of said contract to furnish a bond for the faithful performance of said contract,

NOW THEREFORE, _____
(Name of Principal)

of _____
(Address)

City of _____, State of _____ as Principal, and _____ a corporation organized and existing under the laws of the State of _____, legally doing business in California as an admitted surety insurer at _____, City of _____, State of California, as Surety, are indebted to Morongo Unified School District in the sum of _____ Dollars (\$ _____) for which payment Principal and Surety bind ourselves, our heirs, executors, administrators, successors, and assigns, jointly and severally.

THE CONDITION OF THIS OBLIGATION is that if the Principals, his or its heirs, executors, administrators, successors or assigns, shall keep and perform the covenants, conditions and agreements in the contract and any alteration thereof on his or their part, to be kept and performed at the times and in the manner therein specified and in all respects according to their intent and meaning, and shall indemnify and save harmless the District, its officers, agents, and employees, as therein stipulated, then this obligation shall become null and void, otherwise, it shall remain in full force.

Surety, for value received, hereby stipulates and agrees that no change, extension of time, alteration or addition to the terms of the contract or to the work to be performed thereunder, or the specifications accompanying the same, shall in anywise affect its obligation on this bond, and it does hereby waive notice of any such change, extension of time, alteration or addition to the terms of the contract, or to the work, or to the specifications.

In the event suit is brought upon this bond by the District and judgement is recovered, the Surety shall pay all costs incurred by the District in such suit, including reasonable attorneys fees, to be fixed by the Court.

IN WITNESS WHEREOF, this instrument has been duly executed by the Principal and Surety above named, on the _____ day of _____, 2019.

(Corporate Seal)

Principal

By _____

Typed or Printed Name

Title _____

(Corporate Seal)

Surety

By _____

Typed or Printed Name

(Attach Attorney in Fact Certificate)

Title _____

PAYMENT BOND
100% OF CONTRACT AMOUNT
(Labor and Material Bond)

KNOW ALL MEN BY THESE PRESENT: That

WHEREAS, the MORONGO UNIFIED SCHOOL DISTRICT by
resolution passed _____, **2019**, has awarded
to _____,
designated as the "Contractor", a contract for the work described as follows:

WHEREAS, said contractor is required by Division 4, Part VI, Title III, Chapter 5, (commencing at Section 9550) of the California Civil Code to furnish a bond in connection with said contract;

NOW THEREFORE, we, the undersigned contractor and _____
_____ as surety are held and firmly bound unto the
_____ District in the sum of
_____ Dollars (\$ _____), for
which payment well and truly to be made, we bind ourselves, our heirs, executors, administrators, successors
and assigns, jointly and severally, firmly by these presents.

THE CONDITION OF THIS OBLIGATION IS SUCH that if said contractor, his or its heirs, executors, administrators, successors or assigns, or subcontractors, shall fail to pay any of the persons named in civil Code Section 9100, or amounts due under the Unemployment Insurance Code Section 13020 with respect to work or labor performed by any such claimant, or for any amounts required to be deducted, withheld, and paid over to the Franchise Tax board from the wages of the employees of the contractor and his subcontractors, with respect to such work and labor, then the surety or sureties herein will pay for the same in an amount not exceeding the sum specified in this bond, otherwise the above obligation shall be void. In case suit is brought upon this bond, the said surety will pay a reasonable attorney's fee to be fixed by the court.

This bond shall inure to the benefit of any of the persons named in Civil Code Section 9100 as to give a right of action to such persons or their assignees in any suit brought upon this bond.

And the said surety for value received, hereby stipulates and agrees that no change, extension of time, alteration or addition to the terms of the contract or to the work to be performed thereunder of the specifications accompanying the same shall in anywise affects its obligations on this bond, and it does hereby waive notice of any such change, extension of time, alteration or addition to the terms of the contract, or to the work, or to the specifications.

IN WITNESS WHEREOF, this instrument has been duly executed by the contractor and surety above named, on the _____ day of _____, 2019.

Surety

Contractor

By _____
Attorney-in-Fact

TABLE OF CONTENTS TO THE GENERAL CONDITIONS

1. Definitions	1
2. Specifications.....	1
3. Copies Furnished.....	1
4. Instructions.....	2
5. Extension of Time.....	2
6. Progress Schedule.....	2
7. Contract Security.....	2
8. Assignment.....	2
9. Claims for Damages.....	2
10. Separate Contracts.....	3
11. Subcontracting.....	3
12. District's Right to Terminate Contract.....	4
13. Guarantee.....	4
14. Notice and Service Thereof.....	5
15. Workers.....	5
16. Wage Rates.....	6
17. Apprentices.....	7
18. Hours of Work.....	7
19. Workmen's Compensation Insurance.....	8
20. Public Liability and Property Damage Insurance.....	8
21. Fire Insurance.....	8
22. Proof of Carriage of Insurance.....	8
23. Laws and Regulations.....	8
24. Permits and Licenses.....	9
25. Surveys.....	9
26. Excise Taxes.....	9
27. Patents, Royalties, and Indemnities.....	9
28. Materials.....	9
29. Substitutions.....	10
30. Shop Drawings.....	10
31. Samples.....	10
32. Cost Breakdown and Periodical Estimates.....	11
33. Pavments.....	11
34. Pavments Withheld.....	11
35. Changes and Extra Work.....	12
36. Deductions for Uncorrected Work.....	13

37. Pavments by Contractor.....	13
38. Contractor's Supervisor.....	13
39. Documents on Work.....	14
40. Utilities.....	14
41. Sanitary Facilities.....	14
42. Protection of Work and Property.....	14
43. Cutting and Patching.....	15
44. Cleaning Up.....	16
45. Correction of Work Before Final Pavment.....	16
46. Access to Work.....	16
47. Occupancy.....	16
48. District's Inspector.....	16
49. Tests and Inspections.....	17
50. Soils Investigation.....	17
51. District's Status.....	18
52. District's Decisions.....	18
53. Provisions Required by Law Deemed Inserted.....	18
54. Utilities: Removal. Restoration.....	18
55. Travel and Substistence Pavments.....	19
56. Hold Harmless Agreement.....	19
57. Auditor General Examination and Audit.....	19
58. Substitution of Securities.....	20
59. Mediation and Arbitration of Claims.....	20

General Conditions Attachment #1
General Conditions Attachment #2

GENERAL CONDITIONS

Article 1. DEFINITIONS

- (a) The DISTRICT or OWNER and CONTRACTOR are those mentioned as such in the Agreement. They are treated through in the contract documents as if they are of singular number and masculine gender.
- (b) Subcontractor, as used herein, includes those having direct contract with CONTRACTOR, and one who furnished material worked to a special design according to plans, drawings and specifications of this work, but does not include one who merely furnished material not so worked.
- (c) Surety is the person, firm or corporation that executes as surety the CONTRACTOR'S Performance Bond and Payment Bond.
- (d) Provide shall include "Provide complete in place"; that is, "furnish and install."
- (e) As shown, as indicated, as detailed refer to drawings accompanying this Specification.
- (f) Work of the CONTRACTOR or subcontractor includes labor or materials or both.
- (g) References to Special Conditions shall mean Supplementary General Conditions.

Article 2. SPECIFICATIONS

Contract Documents are complementary, and what is called for by one shall be as binding as if called for by all. The intention of documents is to include all labor and materials, equipment and transportation necessary for the proper execution of the work. Materials or work described in words which so applied has a well know technical or trade meaning shall be deemed to refer to such recognized standards.

Interpretations: Figured dimensions on drawings shall govern, but work not dimensioned shall be as directed. Work not particularly shown or specified shall be same as similar parts that are shown or specified. Large scale details shall take precedence over smaller scale drawings as to shape and details of construction. Specifications shall govern as to materials, workmanship and installation procedures. Drawings and specifications are intended to be fully cooperative and to agree. However, if CONTRACTOR observes that drawings and specifications are in conflict, he shall promptly notify the District in writing. The specification calling for the higher quality material or workmanship shall prevail.

The District shall clarify questions regarding interpretation of drawings and specifications.

Article 3. COPIES FURNISHED

CONTRACTOR will be furnished, free of charge, a maximum of one (1) copy of the bidding drawings and specifications, **Bid #19-01 Re-Painting at Three District Sites**. Additional copies may be obtained at cost of reproduction.

Article 4. INSTRUCTIONS.

Work shall be executed in conformity therewith and CONTRACTOR shall do no work without proper instruction.

Article 5. EXTENSION OF TIME

CONTRACTOR shall not be penalized, as set forth in Paragraph 6 of the Agreement, because of any delays in completion of work due to unforeseeable causes beyond the control and without the fault or negligence of CONTRACTOR, including but not restricted to: acts of God, or of public enemy, acts of government, acts of DISTRICT or anyone employed by it or acts of another contractor in performance of a contract with the DISTRICT, fires, floods, epidemics, quarantine restriction, strikes, and unusually severe weather or delays of subcontractors due to such causes. CONTRACTOR shall within ten (10) days of beginning of any such delay (unless DISTRICT grants in writing a further period of time to file such notice prior to date of final settlement of the contract) notify DISTRICT in writing of causes of delay; thereupon DISTRICT shall ascertain the facts and extend of delay and grant extension of time for completing work when, in its judgment, the findings of fact justify such an extension. The DISTRICT'S findings of fact thereon shall be final and conclusive on the parties hereto.

Article 6. PROGRESS SCHEDULE

Immediately after being awarded contract, CONTRACTOR shall prepare an estimated progress schedule and submit same for DISTRICT'S approval. Schedule shall indicate the beginning and completion dates of all phases of construction.

Article 7. CONTRACT SECURITY

Unless otherwise specified in Special Conditions, CONTRACTOR shall furnish a surety bond in an amount equal to 100 percent of contract price as security for faithful performance of this contract and shall furnish a separate bond in amount equal to 100 percent of the contract price as security for payment of persons performing labor and furnishing materials in connection with this contract.

Article 8. ASSIGNMENT

CONTRACTOR shall not assign this contract or any part thereof without prior written consent of DISTRICT. Any assignment of money due or to become due under this contract shall be subject to prior lien for services rendered or material supplied for performance of work called for under said contract in favor of all personal firms or corporations rendering such services of supplying such materials to the extent that claims are filed pursuant to the Civil Code and the Government Code.

Article 9. CLAIMS FOR DAMAGES

If the CONTRACTOR should claim compensation for any damage sustained by reason of the acts of the DISTRICT or its agents, he shall, within five (5) days after sustaining of such damage, make to the District a written statement of damage sustained. On or before the 15th day of the month succeeding that in which such damage shall have been sustained the CONTRACTOR shall file with the DISTRICT an itemized statement of the details and amount of such damage, and unless such statement shall be made as thus required, his claims for compensation shall be forfeited and invalidated and he shall not be entitled to consideration for payment on account of any such damage.

Article 10. SEPARATE CONTRACTS

DISTRICT reserves the right to let other contracts in connection with this work. CONTRACTOR shall afford other contractors reasonable opportunity for introduction and storage of their materials and execution of their work and shall properly connect and coordinate his work with theirs.

If any part of CONTRACTOR'S work depends for proper execution or results upon work of any other contractor, the CONTRACTOR shall inspect and promptly report to District in writing any defects in such work that render it unsuitable for such proper execution and results. His failure so to inspect and report shall constitute his acceptance of other contractor's work as fit and proper for reception of his work, except as to defects which may develop in other contractor's work after execution of his work.

To insure proper execution of his subsequent work, CONTRACTOR shall measure and inspect work already in place and shall at once report to the District in writing any discrepancy between executed work and contract documents.

CONTRACTOR shall ascertain to his own satisfaction the scope of the project and nature of any other contracts that have been or may be awarded by DISTRICT in prosecution of the project to the end that CONTRACTOR may perform this contract in the light of such other contracts, if any. Nothing herein contained shall be interpreted as granting to CONTRACTOR exclusive occupancy at site of project. CONTRACTOR shall not cause any unnecessary hindrance or delay to any other contractor working on project. If simultaneous execution of any contract for project is likely to cause interference with performance of some other contract or contracts, DISTRICT shall decide which contractor shall cease work temporarily and which contractor shall continue or whether work can be coordinated so that contractors may proceed simultaneously. DISTRICT shall not be responsible for any damages suffered or extra costs incurred by CONTRACTOR resulting directly or indirectly from award or performance or attempted performance of any other contract or contracts on project, or caused by any decision or omission of DISTRICT respecting the order of precedence in performance of contracts.

Article 11. SUBCONTRACTING

(a) CONTRACTOR agrees to bind every subcontractor by terms of this contract as far as such terms are applicable to subcontractor's work. If CONTRACTOR shall subcontract any part of this contract, CONTRACTOR shall be as fully responsible to DISTRICT for acts and omissions of his subcontractor and of persons either directly or indirectly employed by his subcontractor, as he is for acts and omissions of persons either directly or indirectly employed by himself. Nothing contained in contract documents shall create any contractual relation between any subcontractor and DISTRICT.

(b) DISTRICT'S consent to or approval of any subcontractor under this contract shall not in any way relieve CONTRACTOR of his obligations under this contract and no such consent or approval shall be deemed to waive any provision of this contract.

(c) Substitution or addition of sub contractors shall be permitted only as authorized in Chapter 2 (commencing at Section 4100), Division 5, Title 1 of the California Government Code.

Article 12. DISTRICT'S RIGHT TO TERMINATE CONTRACT

If the CONTRACTOR refuses or fails to prosecute the work or any separable part thereof with such diligence as will insure its completion within the time specified or any extension thereof, or fails to complete said work within such time, or if the CONTRACTOR should be adjudged a bankrupt, or if he should make a general assignment for the benefit of his creditors, or if a receiver should be appointed on account of his insolvency, or if he should persistently or repeatedly refuse or should fail, except in cases for which extension of time is provided, to supply enough properly skilled workers or proper materials to complete the work in time specified, or he should fail to make prompt payment to subcontractors or for material or labor, or persistently disregard laws, ordinances or instructions of DISTRICT, or if he or his subcontractors should violate any of the provisions of this contract, then DISTRICT may, without prejudice to any other right or remedy, serve written notice upon him and his surety of its intention to terminate this contract, such notice to contain the reasons for such intention to terminate, and unless within ten days after the service of such notice such condition shall cease or such violation shall cease and arrangements satisfactory to DISTRICT for the correction thereof be made, this contraction shall upon the expiration of said ten days, cease and terminate. In such case, CONTRACTOR shall not be entitled to receive any further payment until work is finished. In event of any such termination, DISTRICT shall immediately serve written notice thereof upon surety and CONTRACTOR, and surety shall have the right to take over and perform this contract, provided, however, that if surety within seven (7) days after service upon it of said notice of termination does not give DISTRICT written notice of its intention to take over and perform this contract or does not commence performance within fifteen (15) days from date of serving such notice of termination by DISTRICT on surety, DISTRICT may take over the work and prosecute same to completion by contract or by any other method it may deem advisable for the account and at the expense of CONTRACTOR, and CONTRACTOR and his surety shall be liable to DISTRICT for any excess cost or other damages occasioned the DISTRICT thereby. IF the district takes over the work as hereinabove provided, the DISTRICT may, without liability for so doing, take possession of and utilize in completing the work such materials appliances, plant, and other property belonging to the CONTRACTOR as may be on the site of the work and necessary therefor.

If unpaid balance of contract price shall exceed expense of finishing work, including compensation for additional architectural, managerial, and administrative services, such excess shall be paid to CONTRACTOR. If such expense shall exceed such unpaid balance, CONTRACTOR shall pay difference to DISTRICT. Expense incurred by DISTRICT as herein provided, and damage incurred through CONTRACTOR'S default, shall be certified by District, whose decision shall be final.

The foregoing provisions are in addition to and not in limitation of any other rights or remedies available to the DISTRICT.

Article 13. GUARANTEE

Besides guarantees required elsewhere, CONTRACTOR shall, and hereby does, guarantee all work for a period of one (1) year after date of acceptance of work by DISTRICT and shall repair or replace any or all such work, together with any other work which may be displace in so doing, that may prove defective in workmanship and/or materials within one year period from date of acceptance without expense whatsoever to DISTRICT, ordinary wear and tear, unusual abuse or neglect excepted. DISTRICT will give notice of observed defects with reasonable promptness. CONTRACTOR shall notify DISTRICT upon completion of repairs.

In the event of failure of CONTRACTOR to commence and pursue with diligence said replacements or repairs within one (1) week after being notified in writing, DISTRICT is hereby authorized to proceed to have defects repaired and made good at expense of CONTRACTOR who hereby agrees to pay costs and charges therefor immediately on demand.

If, in the opinion of the DISTRICT, defective work creates a dangerous condition or required immediate correction or attention to prevent further loss to the DISTRICT or to prevent interruption of operations of the DISTRICT, the DISTRICT will attempt to give notice required by this article. If the CONTRACTOR cannot be contacted or does not comply with the DISTRICT'S request, for correction within a reasonable time as determined by the DISTRICT, the DISTRICT may, notwithstanding the provisions of this article, proceed to make such correction or provide such attention and the costs of such correction or attention shall be charged against the CONTRACTOR. Such action by the DISTRICT will not relieve the CONTRACTOR of the guarantees provided in this article or elsewhere in this contract.

This article does not in any way limit the guarantee on any items for which a longer guarantee is specified or on any items for which a manufacturer gives a guarantee for a longer period. CONTRACTOR shall furnish DISTRICT all appropriate guarantee or warranty certificates upon completion of the project.

Article 14. NOTICE AND SERVICE THEREOF

Any notice from one party to the other under this contract shall be in writing and shall be dated and signed by party giving such notice or by duly authorized representative of such party. Any notice shall not be effective for any purpose whatsoever unless served in one of the following manners:

- (a) If notice is given to DISTRICT, by personal delivery thereof to DISTRICT or by depositing same in United States mails, enclosed in a sealed envelope addressed to DISTRICT, postage prepaid and registered;
- (b) If notice is given to CONTRACTOR, by personal delivery thereof to said CONTRACTOR or to his foreman at site of project, or by depositing same in United States mails, enclosed in a sealed envelope addressed to said CONTRACTOR at his regular place of business or at such other address as may have been established for the conduct of work under this contract, postage prepaid and registered;
- (c) If notice is given to surety or other person, by personal delivery to such surety or other person or by depositing same in United States mails, enclosed in a sealed envelope, addressed to such surety or person at the address of such surety or person last communicated by him to party giving notice, postage prepaid and registered.

Article 15. WORKERS

- (a) CONTRACTOR shall at all times enforce strict discipline and good order among his employees and shall not employ on work any unfit person or anyone not skilled in work assigned to him.
- (b) Any person in the employ of the CONTRACTOR whom DISTRICT may deem incompetent or unfit shall be dismissed from work and shall not again be employed on it except with written consent of DISTRICT.

Article 16. WAGE RATES

Pursuant to the provisions of Article 2 (commencing at Section 1770), Chapter 1 part 7, Division 2 of the Labor Code of California, the governing body of DISTRICT has ascertained the general prevailing rate of per diem wages in the locality in which this public work is to be performed for each craft, classification or type of worker needed to execute the contract. The general prevailing rate of per diem wages determined are set forth in the Notice to Contractors or are available at the District Office.

Holiday and overtime work, when permitted by law, shall be paid for at a rate of at least one and one-half times the above specified rate of per diem wages, unless otherwise specified.

There shall be paid each worker of the CONTRACTOR or any of his subcontractors engaged in work on the project not less than the wage rate listed herein, regardless of any contractual relationship which may be alleged to exist between the CONTRACTOR or any subcontractor and such workers.

Each worker needed to execute the work on the project shall be paid travel and subsistence payments, as such travel and subsistence payments are defined in the applicable collective bargaining agreements filed with the Department of Industrial Relations in accordance with labor Code Section 1773.8.

The CONTRACTOR shall, as a penalty to the DISTRICT forfeit fifty dollars (\$50.00) for each calendar day, or portion thereof, for each worker paid less than the stipulated prevailing rates as determined by the director for such work or craft in which such worker is employed for any public work done under the contract by him or by any subcontractor under him. The difference between such stipulated prevailing wage rates and the amount paid to each worker for each calendar day or portion thereof for which worker was paid less than the stipulated prevailing wage rate shall be paid by the CONTRACTOR.

Any worker employed to perform work on the project, which work is not covered by any classification listed in Notice to Contractors shall be paid not less than the minimum rate of wages specified herein for the classification which most nearly corresponds to work to be performed by him, and such person in such classification.

Pursuant to Labor Code Section 1773.1, per diem wages are deemed to include employer payments for health and welfare, pension, vacation, and similar purposes.

CONTRACTOR and each subcontractor shall keep or cause to be kept an accurate record showing the name, occupation, and actual per diem wages paid to each worker employed by him in connection with this public work. **All contractors and subcontractors must furnish electronic certified payroll records directly to the Labor Commissioner (aka Division of Labor Standards Enforcement).** The phase-in timetable for this requirement is as follows:

June 20, 2014: Any project that was being monitored by the CMU/Labor Commissioner prior to the adoption of SB 854 will continue to be monitored by the Labor Commissioner afterward; and the contractors on those projects must continue to furnish certified payroll records to the Labor Commissioner until the project is complete.

April 1, 2015: For all new projects awarded on or after this date, the contractors and subcontractors must furnish electronic certified payroll records to the Labor Commissioner.

Anytime: For projects besides those listed above, the Labor Commissioner may at any time require the contractors and subcontractors to furnish electronic certified payroll records. *The Labor Commissioner*

anticipates requiring this for green energy school projects that receive Proposition 39 funding.

January 1, 2016: The requirement to furnish electronic certified payroll records to the Labor Commissioner will apply to all public works projects, whether new or ongoing.

Exceptions: The Labor Commissioner may (but is not required to) excuse contractors and subcontractors from furnishing electronic certified payroll records to the Labor Commissioner on a project that is under the jurisdiction of one of the four legacy DIR-approved labor compliance programs (Caltrans, City of Los Angeles, Los Angeles Unified School District, and County of Sacramento) or that is covered by a qualifying project labor agreement.

These new requirements will apply to all public works that are subject to the prevailing wage requirements of the Labor Code, without regard to funding source.

CONTRACTOR shall post at appropriate conspicuous points on the site of project, a schedule showing all determined minimum wage rates and all authorized deductions, if any, from unpaid wages actually earned.

Article 17. APPRENTICES

Apprentices of any crafts or trades may be employed, and when required by Labor code Section 1777.5, shall be employed provided they are properly indentured to the CONTRACTOR in full compliance with provisions of the Labor Code. The CONTRACTOR agrees that he will comply with the provisions of Labor Code Section 1777.5.

Article 18. HOURS OF WORK

As provided in Article 3 (commencing at Section 1810), Chapter 1, Part 7, Division 2 of the Labor Code, eight (8) hours of labor shall constitute a legal day's work. The time of service of any worker employed at any time by the CONTRACTOR or by any sub contractor on any part of this contract is limited and restricted to eight (8) hours per day and forty (40) hours during any one week. Workers shall be permitted to work on this contract in excess of eight (8) hours per day or forty (40) hours per week upon compensation at a minimum of one and one-half times the basic rate of pay.

Every contractor and subcontractor shall keep an accurate record showing the name of and actual hours worked each calendar day and each calendar week by each worker employed by him in connection with the work or any part of the work contemplated by this contract. The record shall be kept open at all reasonable hours to the inspection of the DISTRICT and to the Division of Labor Law Enforcement, Department of Industrial Relations of the State of California.

The CONTRACTOR shall pay to the DISTRICT a penalty of fifty dollars (\$50.00) for each worker employed in the execution of this contract by CONTRACTOR or by any sub contractor for each calendar day during which such worker is required or permitted to work more than eight (8) hours in any calendar day and forty (40) hours in any one calendar week in violation of the provisions of Article 3 (commencing at Section 1810), Chapter 1, Part 7, Division 2 of the Labor code.

Any work necessary to be performed after regular working hours, or on Sundays or other holidays shall be performed without additional expense to DISTRICT.

Article 19. WORKMEN'S COMPENSATION INSURANCE

The CONTRACTOR shall provide, during the life of this contract, workmen's compensation insurance for all of his employees engaged in work under this contract, on or at the site of the project, and, in case any of his work is sublet, the CONTRACTOR shall require the subcontractor similarly to provide workmen's compensation insurance for all the latter's employees. Any class of employee or employees not covered by a subcontractor's insurance shall be covered by the CONTRACTOR'S insurance. In case any class of employees engaged in work under this contract, on or at the site of the project, is not protected under the Workmen's Compensation Statute, the CONTRACTOR shall provide or shall cause a subcontractor to provide, adequate insurance coverage for the protection of such employees not otherwise protected. The CONTRACTOR shall file with the DISTRICT certificates of his insurance protecting workers.

Article 20. PUBLIC LIABILITY AND PROPERTY DAMAGE INSURANCE

CONTRACTOR shall take out and maintain during the life of this contract such public liability and property damage insurance as shall protect him and DISTRICT from all claims for personal injury, including accidental death, as well as from all claims for property damage arising from operations under this contract, in amounts as set forth in the Agreement.

CONTRACTOR shall require his subcontractors, if any, to take out and maintain similar public liability and property damage insurance in appropriate amounts.

Article 21. FIRE INSURANCE

CONTRACTOR **shall not be required to maintain or cause to be maintained fire insurance** on all work subject to loss or damage by fire.

Article 22. PROOF OF CARRIAGE OF INSURANCE

CONTRACTOR shall not commence work nor shall he allow any subcontractor to commence work under this contract until he has obtained all required insurance and certificates which have been delivered in duplicate to and approved by DISTRICT. DISTRICT shall be named as a co-insured in all said insurance policies.

(a) Certificates and insurance policies shall include the following clause:

"This policy shall not be canceled or reduced in required limits of liability or amounts of insurance until notice has been mailed to DISTRICT stating date of cancellation or reduction. Date of cancellation or reduction may not be less than thirty (30) days after date of mailing notice."

(b) Certificates of insurance shall state in particular those insured, extent of insurance, location and operation to which insurance applies, expiration date and cancellation and reduction notice.

Article 23. LAWS AND REGULATIONS

CONTRACTOR shall give all notices and comply with all laws, ordinances, rules, and regulations

bearing on conduct of work as indicated and specified. If CONTRACTOR observed that drawings and specifications are at variance therewith, he shall promptly notify District in writing and any changes deemed necessary by the District shall be adjusted as provided in contract for changes in work. If CONTRACTOR performs any work which he knew, or through exercise or reasonable care should have known, to be contrary to such laws, ordinances, rules or regulations, and without such notice to District, he shall bear all costs arising therefrom.

Article 24. PERMITS AND LICENSES

Permits and licenses necessary for prosecution of work shall be secured and paid for by CONTRACTOR, unless otherwise specified.

Article 25. SURVEYS

Surveys to determine location of property lines and corners will be supplied by DISTRICT. Surveys to determine locations of construction, grading, and site work shall be provided by CONTRACTOR.

Article 26. EXCISE TAXES

If under federal excise tax law transaction hereunder constitutes a federal excise tax is imposed and the sale is exempt from such excise tax because it is a sale to a state or local government for its exclusive use, the DISTRICT, upon request, will execute a certificate of exemption which will certify (1) that the DISTRICT is a political subdivision of the State for the purpose of such exemption and (2) that the sale is for the exclusive use of the DISTRICT. No excise tax for such materials shall be included in any bid price.

Article 27. PATENTS, ROYALTIES, AND INDEMNITIES

The CONTRACTOR shall hold and save the DISTRICT and its officers, agents, and employees harmless from liability of any nature or kind, including cost and expense, for or on account of any patented or unpatented invention, process, article, or appliance manufactured or used in the performance of this contract, including its use by the DISTRICT, unless otherwise specifically stipulated in the contract documents.

Article 28. MATERIALS

Unless otherwise specifically stated in this contract, CONTRACTOR shall provide and pay for all materials, labor, tools, equipment, water, light, power, transportation, superintendence, facilities of every nature whatsoever necessary to execute and complete this contract within specified time.

Unless otherwise specified, all materials shall be new and both workmanship and materials shall be of good quality.

Materials shall be furnished in ample quantities and at such time as to insure uninterrupted progress of work and shall be stored properly and protected as required. CONTRACTOR shall be entirely responsible for damage or loss by weather or other causes to materials or work under this contract.

No material, supplies, or equipment for work under this contract shall be purchased subject to any chattel mortgage or under a conditional sale or other agreement by which an interest therein or in any part thereof is retained by a seller or supplier. CONTRACTOR warrants good title to all material, supplies, and equipment installed or incorporated in work and agrees upon completion of all work to deliver

premises, together with all improvements and appurtenances constructed or placed thereon by him, to DISTRICT free from any claims, liens, or charges. He further agrees that neither he nor any person, firm or corporation furnishing any materials or labor for any work covered by this contract shall have any right to lien upon premises or any improvement or appurtenance thereon, except that CONTRACTOR may install metering devices or other equipment of utility companies or of political subdivisions, title to which is commonly retained by utility company or political subdivision. In event of installation of any such metering device or equipment, CONTRACTOR shall advise DISTRICT as to owner thereof. Nothing contained in this article, however, shall defeat or impair right of persons furnishing material or labor under any bond given by CONTRACTOR for their protection or any rights under any law permitting such persons to look to funds due CONTRACTOR in hands of DISTRICT, and these such persons to look to funds due CONTRACTOR in hands of DISTRICT, and these provisions shall be given to all persons furnishing material.

Article 29. SUBSTITUTIONS

Whenever in specifications any materials, process, or article is indicated or specified by grade, patent, or proprietary name or by name of manufacturer, such specification shall be deemed to be sued for the purpose of facilitating description of material, process or article desired and shall be deemed to be followed by the words "or equal," and CONTRACTOR may, unless otherwise stated, offer any material, process, or article which shall be substantially equal or better in every respect to that so indicated or specified. If material, process, or article offered by CONTRACTOR is not, in opinion of Architect or DISTRICT, substantially equal or better in every respect to that specified, the CONTRACTOR shall furnish material, process, or article specified. Burden of proof as to equality of any material, process, or article shall rest with CONTRACTOR. CONTRACTOR shall submit request together with substantiating data for substitution of an "or equal" item within thirty-five (35) days after award of contract. Provision authorizing submission of "or equal" justification data shall not in any way authorize an extension of time for performance of this contract.

In event CONTRACTOR furnishes material, process or article more expensive than that specified difference in cost of such material, process, or article so furnished shall be borne by CONTRACTOR.

Article 30. SHOP DRAWINGS

CONTRACTOR shall check and verify all field measurements and shall submit with such promptness as to cause no delay in his own work or in that of any other contractor six (6) copies checked and approved by him of all shop or setting drawings, schedules, and materials list required for the work of various trades. District shall check and approve or disapprove within ten (10) days such schedules and drawings only for conformance with design concept of project and compliance with information given in contract documents. CONTRACTOR shall make any corrections required by District, file with him three (3) corrected copies and furnish six (6) corrected copies and furnish such other copies as may be needed for construction. District's approval of such drawings or schedules shall not relieve CONTRACTOR from responsibility for deviations from drawings or specifications unless he has in writing called District's attention to such deviations at time of submission and secured District's written approval, nor shall it relieve him from responsibility for errors in shop drawings or schedules.

Article 31. SAMPLES

CONTRACTOR shall furnish for approval, within fifteen (15) days following award of contract, all samples as required in specifications together with catalogs and supporting data required by District.

This provision shall not authorize any extension of time for performance of this contract. District will check and approve or disapprove such samples, within ten (10) working days from receipt of same, as to conformance with design concept of work and for compliance with information given in contract documents. Work shall be in accordance with approved samples.

Article 32. COST BREAKDOWN AND PERIODICAL ESTIMATES

CONTRACTOR shall furnish:

- (a) Within ten (10) days of award of contract a detailed estimate giving complete breakdown of contract price for each project or site; and
- (b) Within ten (10) days of request by DISTRICT, a schedule of estimated monthly payments which shall be due him under the contract.

Values employed in making up any of these schedules will be used only for determining basis of partial payments and will not be considered as fixing a basis for additions too or deductions from contract price.

Article 33. PAYMENTS

Each month with twenty (20) days after receipt of approved periodical estimate for partial payment, there shall be paid to CONTRACTOR a sum equal to ninety-five percent (95%) of value of work performed and of materials delivered on the ground or stock subject to or under the control of the DISTRICT and unused up to the last day of the previous month, less aggregate previous payments. Monthly payments shall be made only on the basis of monthly estimates which shall be prepared by CONTRACTOR on a form approved by DISTRICT and filed before the fifth day of the month during which payment is to be made. Work completed as estimated shall be an estimate only and no inaccuracy or error in said estimate shall operate to release CONTRACTOR or any bondsman from any damages arising from such work or from enforcing each and every provision of this contract, and DISTRICT shall have the right subsequently to correct any error made in any estimate for payment. CONTRACTOR shall not be entitled to have any payment estimates processed or be entitled to have any payment for work performed so long as any lawful or proper direction concerning work, or any portion thereof, given by the DISTRICT shall remain un-complied with. The final payment of five percent (5%) of the value of the work done under this contract if unencumbered shall be made thirty-five (35) days after recording by the DISTRICT of the Notice of Completion. Acceptance will be made only by an action of the governing board of DISTRICT. Acceptance by CONTRACTOR of said final payment shall constitute a waiver of all claims against DISTRICT arising from this contract.

Article 34. PAYMENTS WITHHELD

In addition to amount which DISTRICT may retain under article entitled "PAYMENTS," DISTRICT may withhold a sufficient amount or amounts of any payment or payments otherwise due to CONTRACTOR, as in its judgment may be necessary to cover:

- (a) Payments which may be past due and payable for just claims against CONTRACTOR or any subcontractors for labor or materials furnished in and about the performance of work on the project under this contract.
- (b) Defective work not remedied.
- (c) Failure of CONTRACTOR to make proper payments to this subcontractor or for material or labor.

(d) Completion of contract if there exists a reasonable doubt that contract can be completed for balance then unpaid.

(3) Damage to another contractor.

If the above grounds are in the opinion of the DISTRICT removed, payment shall be made for amounts withheld because of them.

DISTRICT may apply such withheld amount or amounts to payment of such claims or obligations at its discretion. In so doing, DISTRICT shall be deemed the agent of CONTRACTOR and any payment so made by DISTRICT shall be considered as payment made under contract by DISTRICT to CONTRACTOR and DISTRICT shall not be liable to CONTRACTOR for such payments made in good faith. Such payments may be made without prior judicial determination of claim or obligations. DISTRICT will render CONTRACTOR an accounting of such funds disbursed on behalf of CONTRACTOR.

Article 35. CHANGES AND EXTRA WORK

DISTRICT, without invalidating contract, and as provided by law, may order extra work or make changes by altering, adding to, or deducting from work, contract sum being adjusted accordingly. All such work shall be executed under conditions of original contract except that any claim for extension of time caused thereby shall be adjusted at time of ordering such change.

In giving instructions, District shall have authority to make minor changes in work, not involving change in cost, and not inconsistent with purposes of building. Otherwise, except in an emergency endangering life or property, no extra work or change shall be made unless in pursuance of a written order from DISTRICT, and no claim for addition to contract sum shall be valid unless so ordered.

Value of any such extra work, change, or deduction shall be determined at the discretion of DISTRICT in one or more of the following ways:

- (a) By acceptable lump sum proposal from CONTRACTOR .
- (b) By unit prices contained on CONTRACTOR'S original bid and incorporated in contract documents or fixed by subsequent agreement between DISTRICT and CONTRACTOR.
- (c) By cost of material and labor and percentage for overhead and profit. The following form shall be used as applicable by the DISTRICT and CONTRACTOR to communicate proposed additions and deletions to contract:

	<u>EXTRA</u>	<u>CREDIT</u>
1. Material (attach itemized quantity and unit cost, plus sales tax)	_____	_____
2. Labor (attach itemized hours and rates)	_____	_____
3. Subtotal	_____	_____
4. Contractor/Subcontractor's overhead and profit, not to exceed 15% of the total of Item 3.	_____	_____

- 5. P.I. and P.D., Compensation Insurance, Social Security and

Unemployment Taxes, no to exceed 10% of Item 3.

- | | | | |
|----|---|--|--|
| 6. | Subtotal | | |
| 7. | Bond Premium, not to exceed 1% of Item 6. | | |
| 8. | Total | | |

If the CONTRACTOR should claim that any instruction, request, drawing specification, action, condition, omission, default, or other situation obligates the DISTRICT to pay additional compensation to the CONTRACTOR or to grant an extension of time for the completion of the contract, or constitutes a waiver of any provision in the contract, he shall notify the DISTRICT, in writing, of such claim within ten (10) days from the date he has actual or constructive notice of the factual basis supporting the claim. The CONTRACTOR'S failure to notify the DISTRICT within such ten-day period shall not disadvantage the DISTRICT. If such notice be given within the specified time, the procedure for its consideration shall be as stated above in this article.

Article 36. DEDUCTIONS FOR UNCORRECTED WORK

If DISTRICT deems it inexpedient to correct work injured or done not in accordance with contract, an equitable deduction from contract price shall be made therefor.

Article 37. PAYMENTS BY CONTRACTOR

CONTRACTOR shall pay:

- (a) For all transportation and utility services not later than the 20th day of the calendar month following that in which such services are rendered;
- (b) For all materials, tools, and other expendable equipment to the extent of ninety-five percent (95%) of cost thereof, not later than the 20th day of the calendar month following that in which such materials, tools, and equipment re delivered at site of project and balance of cost thereof not later than the 30th day following completion of that part of work in or on which such materials, tools, and equipment are incorporated or used; and
- (c) To each of his subcontractors, not later than the 5th day following each payment to CONTRACTOR: the respective amounts allowed CONTRACTOR on account of work performed by respective subcontractor to the extent of such subcontractor's interest therein.

Article 38. CONTRACTOR'S SUPERVISOR

Unless personally present on premises where work is being done, CONTRACTOR shall keep on the work, during its progress, a competent superintendent satisfactory to District. Superintendent shall not be changed except with written consent of District. Superintendent shall represent CONTRACTOR in his absence and all directions given to superintendent shall be as binding as if given to CONTRACTOR.

CONTRACTOR shall give efficient supervision to work, using his best skill and attention. He shall carefully study and compare all drawings, specifications, and other instructions and shall at once report to District any error, inconsistency or omission which he may discover.

Article 39. DOCUMENTS ON WORK

CONTRACTOR shall keep one copy of all contract documents, including addenda change orders, and Titles 19, 21 and 24 of the California Administrative Code, which is a part of contract documents, on job at all times. Said documents shall be kept in good order and available to District and his representatives.

CONTRACTOR shall be acquainted with and comply with the provisions of said Titles as they relate to this project (see particularly the duties of contractor, 21 Cal. Admin. Code Sec. 35).

Article 40. UTILITIES

All utilities, including but not limited to electricity, water, gas, telephone used on work shall be furnished and paid for by CONTRACTOR. CONTRACTOR shall furnish and install necessary temporary distribution systems, including meters, if necessary, from distribution points to points on site where utility is necessary to carry on the work. Upon completion of work CONTRACTOR shall remove all temporary distribution systems.

If contract is for repair or addition to existing facility, CONTRACTOR may, with written permission of DISTRICT, use DISTRICT'S existing utilities by making prearranged payments to DISTRICT for utilities used by CONTRACTOR for construction.

Article 41. SANITARY FACILITIES

The CONTRACTOR shall provide sanitary temporary toilet facilities as required by law and such additional facilities as may be directed by the Inspector for the use of all workers. The facilities shall be maintained in a sanitary condition at all times and shall be left at the site until removal as directed by the Inspector. Use of toilet facilities in the work under construction shall not be permitted except by approval of the Inspector.

Article 42. PROTECTION OF WORK AND PROPERTY

The CONTRACTOR shall be responsible for all damages to persons or property that occur as a result of his fault or negligence in connection with the prosecution of this contract and shall be responsible for the proper care and protection of all materials delivered and work performed until completion and final acceptance by the DISTRICT. All work shall be solely at the CONTRACTOR'S risk with the exception of damage to the work caused by "acts of God" as defined in Government Code Section 4151 (b). He shall adequately protect adjacent property from settlement or loss of lateral support as provided by law and contract documents. CONTRACTOR shall take all necessary precautions for safety of employees on the work and shall comply with all applicable safety laws and building codes to prevent accidents or injury to persons on, about, or adjacent to premises where work is being performed. He shall erect and properly maintain at all times, as required by conditions and progress of work, all necessary safeguards, signs, barriers, lights, and watchmen for protection of workers and the public and shall post danger signs warning against hazards created by such features in the course of construction. He shall designate a responsible member of his organization on the work, whose duty shall be prevention of accidents. Name and position of person so designated shall be reported to DISTRICT by CONTRACTOR.

In an emergency affecting safety of life or of work or of adjoining property, CONTRACTOR, without special instruction or authorization from DISTRICT, is hereby permitted to act, at his discretion, to prevent such threatened loss or injury; and he shall so act if so authorized or instructed by DISTRICT. Any compensation claimed by CONTRACTOR on account of emergency work shall be determined by agreement.

CONTRACTOR shall provide such heat, covering and enclosures as are necessary to protect all work, materials, equipment, appliances, and tools against damage by weather conditions.

CONTRACTOR shall take adequate precautions to protect existing sidewalks, curbs, pavements, utilities, adjoining property, and structures, and to avoid damage thereto, and repair any damage thereto caused by construction operations.

CONTRACTOR shall:

Enclose working area with a substantial barricade, arrange work to cause minimum amount of inconvenience and danger to students and faculty in their regular school activities.

Provide substantial barricades around any shrubs or trees indicated to be preserved.

When directed by DISTRICT, take preventive measures to eliminate objectionable dust.

Confine his apparatus, the storage of materials, and the operations of his workers to limits indicated by law, ordinances, permits, or directions of District and shall not unreasonably encumber premises with his materials, and enforce all instructions of DISTRICT and Inspector regarding signs, advertising, fires, danger signals, barricades, and smoking and require that all persons employed on work comply with all regulations while on construction site.

Take care to prevent disturbing or covering any survey markers, monuments, or other devices marking property boundaries or corners. If such markers are disturbed by accident, they shall be replaced by an approved civil engineer at no cost to the DISTRICT.

Article 43. CUTTING AND PATCHING

CONTRACTOR shall do all cutting, fitting, or patching of work as required to make its several parts come together properly and fit it to receive or be received by work or other contractors showing on, or reasonably implied by, the drawings and specifications for the completed structure, and he shall make good after them as District may direct.

All cost caused by defective or ill-timed work shall be borne by CONTRACTOR.

CONTRACTOR shall not endanger any work by cutting, excavating, or otherwise altering work and shall not cut or alter work of any other contractor save with consent of District.

Article 44. CLEANING UP

CONTRACTOR at all times shall keep premises free from debris such as waste, rubbish, and excess materials and equipment caused by this work; debris shall be removed from premises. CONTRACTOR shall not leave debris under, in, or about the premises. Upon completion of work, he shall clean interior and exterior of building, including fixtures, equipment, walls, floors, ceilings, roofs, window sills and ledges, horizontal projections, and any areas where debris has collected so surfaces are free from foreign material or discoloration; he shall clean and polish all glass, plumbing fixtures, and finish hardware and similar finish surfaces and equipment and remove temporary, barricades, planking and construction toilet and similar temporary facilities from site.

Article 45. CORRECTION OF WORK BEFORE FINAL PAYMENT

CONTRACTOR shall promptly remove from premises all work identified by DISTRICT as failing to conform to contract, whether incorporated or not. CONTRACTOR shall promptly replace and re-execute his own work to comply with contract documents without additional expense to DISTRICT and shall bear the expense of making good all work of other contractors destroyed or damaged by such removal or replacement.

If CONTRACTOR does not remove such work within a reasonable time, fixed by written notice, DISTRICT may remove it and may store the material at CONTRACTOR'S expense. If CONTRACTOR does not pay expenses of such removal within ten (10) days' time thereafter, DISTRICT may, upon ten (10) days' written notice, sell such materials at auction or at private sale and shall account for net proceeds thereof, after deducting all costs and expenses that should have been borne by CONTRACTOR.

Article 46. ACCESS TO WORK

DISTRICT and its representatives shall at all times have access to work wherever it is in preparation or progress. CONTRACTOR shall provide safe and proper facilities for such access so that DISTRICT'S representatives may perform their functions under the contract.

Article 47. OCCUPANCY

DISTRICT reserves the right to occupy buildings at any time before completion, and such occupancy shall not constitute final acceptance of any part of work covered by this contract, nor shall such occupancy extend the date specified for completion of the work.

Article 48. DISTRICT'S INSPECTOR

An Inspector employed by DISTRICT in accordance with requirements of Title 21 of the California Administrative Code may be assigned to the work. His duties are specifically defined in Section 34 of said Title 21.

All work shall be under observation of said Inspector. He shall have free access to any or all parts of work at any time. He shall have free access to any or all parts of work at any time. CONTRACTOR shall furnish Inspector reasonable opportunities for obtaining such information as may be necessary to keep him fully informed respecting progress and manner of work and character of materials. Inspection of work shall not relieve CONTRACTOR from any obligation of fulfill this contract. Inspector or District shall have authority to stop work whenever provisions of contract documents are not being complied with and CONTRACTOR shall instruct his employees accordingly.

Article 49. TESTS AND INSPECTIONS

If contract, DISTRICT'S instructions, laws, ordinances, or any public authority require any work to be specifically tested or approved, CONTRACTOR shall give notice in accordance with such authority of his readiness for observation or inspection at least two (2) working days prior to being tested or covered up. If inspection is by authority other than DISTRICT, CONTRACTOR shall inform DISTRICT of date fixed for such inspection. Required certificates of inspection shall be secured by CONTRACTOR. Observations by DISTRICT shall be promptly made, and where practicable at source of supply. If any work should be covered up without approval or consent of DISTRICT, it must, if required by DISTRICT, be uncovered for examination and satisfactorily reconstructed at CONTRACTOR'S expense in compliance with contract. Costs of tests of any materials found to be not in compliance with contract shall be paid for by CONTRACTOR. Other costs for tests and inspection of materials shall be paid by DISTRICT unless specifically provided otherwise.

CONTRACTOR shall notify DISTRICT a sufficient time in advance of manufacture of materials to be supplied by him under contract, which must by terms of contract be tested, in order that DISTRICT may arrange for testing of same at source of supply. Any materials shipped by CONTRACTOR from source of supply prior to having satisfactorily passed such testing and inspection, or prior to receipt of notice from said representative that such testing and inspection will not be required, shall not be incorporated in work without prior approval of DISTRICT and subsequent testing and inspection.

Re-examination of questioned work may be ordered by DISTRICT and, if so ordered, work must be uncovered by CONTRACTOR. If such work be found in accordance with contract documents, DISTRICT shall pay costs of re-examination and replacement. If such work be found not in accordance with contract documents, CONTRACTOR shall pay such costs.

Article 50. SOILS INVESTIGATION

This section mandates that any public works contract which involves digging trenches or other excavations that extend more than four (4) feet below the surface require that the CONTRACTOR shall promptly, before conditions are disturbed, notify the DISTRICT in writing of: (a) any material the CONTRACTOR believes may be hazardous waste; (b) subsurface or latent physical conditions at the site differing from those indicated; (c) unknown physical conditions of any unusual nature, different materially from those ordinarily encountered and generally recognized as inherent in work of the character provided for in the contract.

Once notified, pursuant to Section 7104(b), the DISTRICT is obligated to investigate and if hazardous waste is involved, or conditions do materially differ and cause an increase or decrease in the CONTRACTOR'S cost of, or time required for, performance of any part of the work, a change order must be issued. If a dispute arises between the DISTRICT and the CONTRACTOR, as to the conditions or a change in cost or required time for completion, the CONTRACTOR will not be excused from any scheduled completion date but shall have rights provided by contract or law regarding the resolution of the dispute. For your convenience, we have attached a copy of Section 7104.**

Article 51. DISTRICT'S STATUS

The Director of Maintenance and Operations, or other assigned personnel shall be the DISTRICT'S representative during construction period and he shall observe the progress and quality of the work on behalf of the DISTRICT. He shall have the authority to act on behalf of DISTRICT only to the extent expressly provided in the contract documents. He shall have authority to stop work whenever such stoppage may be necessary in his reasonable opinion to insure the proper execution of the contract.

The DISTRICT shall be, in the first instance, the judge of the performance of this contract.

Article 52. DISTRICT'S DECISIONS

The DISTRICT shall, within a reasonable time, make decisions on all claims of the DISTRICT or CONTRACTOR and on all other matters relating to the execution and progress of the work.

Article 53. PROVISIONS REQUIRED BY LAW DEEMED INSERTED

Each and every provision of law and clause required by law to be inserted in this contract shall be deemed to be inserted herein and the contract shall be read and enforced as though it were included herein, and if through mistake or otherwise any such provision is not inserted, or is not correctly inserted, then upon application of either party the contract shall forthwith be physically amended to make such insertion or correction.

Article 54. UTILITIES; REMOVAL, RESTORATION

Pursuant to Government Code Section 4215, the DISTRICT assumes the responsibility for removal, relocation, and protection of utilities located on the construction site at the time of commencement of construction under this contract with respect to any such utility facilities which are not identified in the plans and specifications. The CONTRACTOR shall not be assessed for delay in completion of the project caused by failure of the DISTRICT to provide for removal or relocation of such utility facilities. DISTRICT shall compensate the CONTRACTOR for the costs of locating, repairing damage not due to the failure of the CONTRACTOR to exercise reasonable care, and removing or relocating such utility facilities not indicated in the plans and specifications with reasonable accuracy, and for equipment necessarily idle during such work.

The Article shall not be construed to preclude assessment against the CONTRACTOR for any other delays in completion of the work. Nothing in this Article shall be deemed to require the DISTRICT to indicate the presence of existing service laterals or appurtenances whenever the presence of such utilities on the site of the construction project can be inferred from presence of other visible facilities, such as buildings, meter junction boxes, on or adjacent to the site of the construction.

If the CONTRACTOR, while performing work under this contract, discovers utility facilities not identified by the DISTRICT in the contract plans or specifications, he shall immediately notify the DISTRICT and the utility in writing.

Article 55. TRAVEL AND SUBSISTENCE PAYMENTS

Each worker needed to execute the work must be paid travel and subsistence payments as defined in the applicable collective bargaining agreements filed in accordance with Labor Code Section 1773.

Article 56. HOLD HARMLESS AGREEMENT

The CONTRACTOR agrees to and does hereby indemnify and hold harmless the DISTRICT, its officers, agents and employees from every claim or demand made and every liability, loss, damage or expense of any nature whatsoever, which may be incurred by reason of:

(a) Liability for damages for (1) death or bodily injury to persons, (2) injury to property, or (3) any other loss, damage or expense arising under either (1) or (2) above, sustained by the Contractor or any person, firm or corporation employed by the CONTRACTOR upon or in connection with the work called for in this Agreement, except for liability for damages referred to above which result from the sole negligence or willful misconduct of the DISTRICT, its officers, employees, agents or independent contractors who are directly employed by the DISTRICT, or for defects in design furnished by such persons.

(b) Any injury to or death of persons or damage to property, sustained by any person, firm or corporation, including the DISTRICT, arising out of, or in any way connected with the work covered by this Agreement, whether said injury or damage occurs either on or off school district property, except for liability for damages which result from the sole negligence or willful misconduct of the DISTRICT, its officers, employees, agents or independent contractors who are directly employed by the DISTRICT, or for defects in design furnished by such persons.

(c) The CONTRACTOR, at his own expense, cost, and risk shall defend any and all actions, suits, or other proceeding that may be brought or instituted against the DISTRICT, its officers, agents, or employees on any such claim, demand or liability, and shall pay or satisfy judgment that may be rendered against the DISTRICT, its officers, agents or employees in any action, suit or other proceedings as a result thereof.

Article 57. AUDITOR GENERAL EXAMINATION AND AUDIT

Pursuant to Government code Section 10532, the contracting parties shall be subject to the examination and audit of the Auditor General of the State of California for a period of three (3) years after final payment under the contract.

Article 58. SUBSTITUTION OF SECURITIES

Pursuant to Public Contract Code Section 22300, CONTRACTOR may request in writing the substitution of securities, at CONTRACTOR'S expense, for any monies withheld by DISTRICT to ensure performance. DISTRICT may, as a condition of granting the request, impose requirements relating to the ownership of the securities and the terms and conditions of the deposit, which requirements shall be consistent with Government Code Section 4590. DISTRICT may refuse to permit the substitution of securities if its requirements are not complied with by CONTRACTOR.

Article 59. MEDIATION AND ARBITRATION OF CLAIMS

Pursuant to Public Contract Code Section 20104(c), the current provisions of Article 1.5 of Chapter 1 of Part 3 of the Public Contract Code (commencing with Section 20104) dealing with the mediation and arbitration of public works claims are incorporated herein and a copy of these provisions are attached to these General Conditions.**

PUBLIC CONTRACT CODE

□ 7104. Contracts for digging trenches or excavations; notice on discovery of hazardous waste or other unusual conditions; investigations; change orders; effect on contract

Any public works contract of a local public entity which involved digging trenches or other excavations that extend deeper than four feet below the surface shall contain a clause which provides the following:

(a) That the contractor shall promptly, and before the following conditions are disturbed, notify the public entity, in writing, of any:

(1) Material that the contractor believes may be material that is hazardous waste, as defined in Section 25117 of the Health and Safety Code that is required to be removed to a Class I, Class II, or Class III disposal site in accordance with provisions of existing law.

(2) Subsurface or latent physical conditions at the site differing from those indicated.

(3) Unknown physical conditions at the site of any unusual nature, different materially from those ordinarily encountered and generally recognized as inherent in work of the character provided for in the contract.

(b) That the public entity shall promptly investigate the conditions, and if it finds that the conditions do materially so differ, or do involve hazardous waste, and cause a decrease or increase in the contractor's cost of, or the time required for, performance of any part of the work shall issue a change order under the procedures described in the contract.

(c) That, in the event that a dispute arises between the public entity and the contractor whether the conditions materially differ, or involve hazardous waste, or cause a decrease or increase in the contractor's cost of, or time required for, performance of any part of the work, the contractor shall not be excused from any scheduled completion date provided for by the contract, but shall proceed with all work to be performed under the contract. The contractor shall retain any and all rights provided either by contract or by law which pertain to the resolution of disputes and protests between the contracting parties.

(Added by Stats.1989, c. 300, □1.)

Article 1.5. Resolution of Construction Claims

20104. (a) (1) This article applies to all public works claims of three hundred seventy-five thousand dollars (\$375,000) or less which arise between a contractor and a local agency.

(2) This Article shall not apply to any claims resulting from a contract between a contractor and a public agency when the public agency has elected to resolve any disputes pursuant to Article 7.1 (commencing with section 10240) of Chapter 1 of Part 2.

(b) (1) "Public work" has the same meaning as in Sections 3100 and 3106 of the Civil Code, except that "public work" does not include any work or improvement contracted for by the state or the Regents of the University of California.

(2) "Claim" means a separate demand by the contractor for (A) a time extension, (B) payment of money or damages arising from work done by or on behalf of the contractor pursuant to the contract for a public work and payment of which is not otherwise expressly provided for or the claimant is not otherwise entitled to, or (C) an amount the payment of which is disputed by the local agency.

(c) The provisions of this article or a summary thereof shall be set forth in the plans or specifications for any work which may give rise to a claim under this article.

(d) This article applies only to contracts entered into on or after January 1, 1991.

20104.2 For any claim subject to this article, the following requirements apply:

(a) The claim shall be in writing and include the documents necessary to substantiate the claim. Claims must be filed on or before the date of final payment. Nothing in this subdivision is intended to extend the time limit or supersede notice requirements otherwise provided by contract for the filing of claims.

(b) (1) For claims of less than fifty thousand dollars (\$50,000), the local agency shall respond in writing to any written claim within 45 days of receipt of the claim, or may request, in writing, within 30 days of receipt of the claim, any additional documentation supporting the claim or relating to defenses or claims the local agency may have against the claimant.

(2) If additional information is thereafter required, it shall be requested and provided pursuant to this subdivision, upon mutual agreement of the local agency and the claimant.

(3) The local agency's written response to the claim, as further documented, shall be submitted to the claimant within 15 days after receipt of the further documentation or within a period of time no greater than that taken by the claimant in producing the additional information, whichever is greater.

(c) (1) For claims of over fifty thousand dollars (\$50,000) and less than or equal to three hundred seventy-five thousand dollars (\$375,000), the local agency shall respond in writing to all written claims within 60 days of receipt of the claim, or may request, in writing, within 30 days of receipt of the claim, any additional documentation supporting the claim or relating to defenses or claims the local agency may have against the claimant.

(2) If additional information is thereafter required, it shall be requested and provided pursuant to this subdivision, upon mutual agreement of the local agency and the claimant.

(3) The local agency's written response to the claim, as further documented, shall be submitted to the claimant within 30 days after receipt of the further documentation, or within a period of time no greater than that taken by the claimant in producing the additional information or requested documentation, whichever is greater.

(d) If the claimant disputes the local agency's written response, or the local agency fails to respond within the time prescribed, the claimant may so notify the local agency, in writing, either within 15 days of receipt of the local agency's response or within 15 days of the local agency's failure to respond within the time prescribed, respectively, and demand an informal conference to meet and confer for settlement of the issues in dispute. Upon a demand, the local agency shall schedule a meet and confer conference within 30 days for settlement of the dispute.

(e) If following the meet and confer conference the claim or any portion remains in dispute, the claimant may file a claim pursuant to Chapter 1 (commencing with Section 900) and Chapter 2 (commencing with Section 910) of Part 3 of Division 3.6 of Title 1 of the Government Code. For purposes of those provisions, the running of the period of time within which a claim must be filed shall be tolled from the time the claimant submits his or her written claim pursuant to subdivision (a) until the time after claim is denied, including any period of time utilized by the meet and confer conference.

20104.4 The following procedures are established for all civil actions filed to resolve claims subject to this article:

(a) Within 60 days, but no earlier than 30 days, following the filing or responsive pleadings, the court shall submit the matter to non-binding mediation unless waived by mutual stipulation of both parties. The mediation process shall provide for the selection within 15 days of both parties of a disinterested third person as mediator, shall be commenced within 30 days of the submittal, and shall be concluded within 15 days from the commencement of the mediation unless a time requirement is extended upon a good cause showing to the court.

(b) (1) If the matter remains in dispute, the case shall be submitted to judicial arbitration pursuant to Chapter 2.5 (commencing with Section 1141.0) of Title 3 of Part 3 of the Code of Civil Procedure, notwithstanding Section 1141.11 of that code. The Civil Discovery Act of 1986 (Article 3 [commencing with Section 2106] of Chapter 3 of Title 3 of Part 4 of the Code of Civil Procedure) shall apply to any proceeding brought under this subdivision consistent with the rules pertaining to judicial arbitration.

(2) In addition to Chapter 2.5 (commencing with Section 1141.10) of Title 3 of Part 3 of the Code of Civil Procedure, (A) arbitrators shall, when possible, be experienced in construction law, and (B) any party appealing an arbitration award who does not obtain a more favorable judgment shall, in addition to payment of costs and fees under that chapter, also pay the attorney's fees on appeal of the other party.

20104.6 (a) No local agency shall fail to pay money as to any portion of a claim which is undisputed except as otherwise provided in the contract.

(b) In any suit filed under Section 20104.4, the local agency shall pay interest at the legal rate on any arbitration award or judgment. The interest shall begin to accrue on the date the suit is filed in a court of law.

Scope of Work

**Specifications
&
Site Plans**

BID #19-01

Re-Painting at Three District Sites

**(Condor Elementary School, District Office &
Yucca Mesa Elementary School)**

Bid #19-01 Re-Painting at Three District Sites

SCOPE OF WORK:

Provide a total cost for re-painting the exterior of the buildings noted for the following sites below:

- **Condor Elementary School:**
 - ❖ Exterior of portable buildings to be re-painted only; paint color scheme to match existing main building (*main building will not be re-painted*).
- **Morongo Unified School District, Main District Offices:**
 - ❖ Re-paint exterior of all District Office buildings/portables, portable restroom & maintenance shop office; (*excluding warehouse, publications and maintenance shop*)
- **Yucca Mesa Elementary School:**
 - ❖ Entire school campus to be re-painted (*all buildings/classroom portables*) .

The following information is provided:

- 1.) Patch stucco as needed to match the existing texture using industry standards, (*if applicable.*)
- 2.) Apply primer paint to entire exterior of buildings/portables.
- 3.) Apply elastomeric paint to exterior of buildings/portables.
- 4.) Prep & paint all doors and trim.
- 5.) All debris shall be removed from site after completion. Due to safety of site, any safety hazards should be taken care of in a timely manner.
- 6.) District to provide restroom access, water and electrical access.

See attached drawings for more project details.

*****Note: Additional project specifications will be provided at the site job walk *****

*Condor Elementary School
Site Plan*

Drawn by Glenn R. Adkins

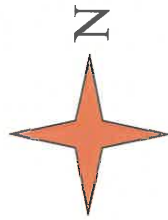

PRR

*Painting all portable buildings 'only' on this site -
Exclude buildings A & B*

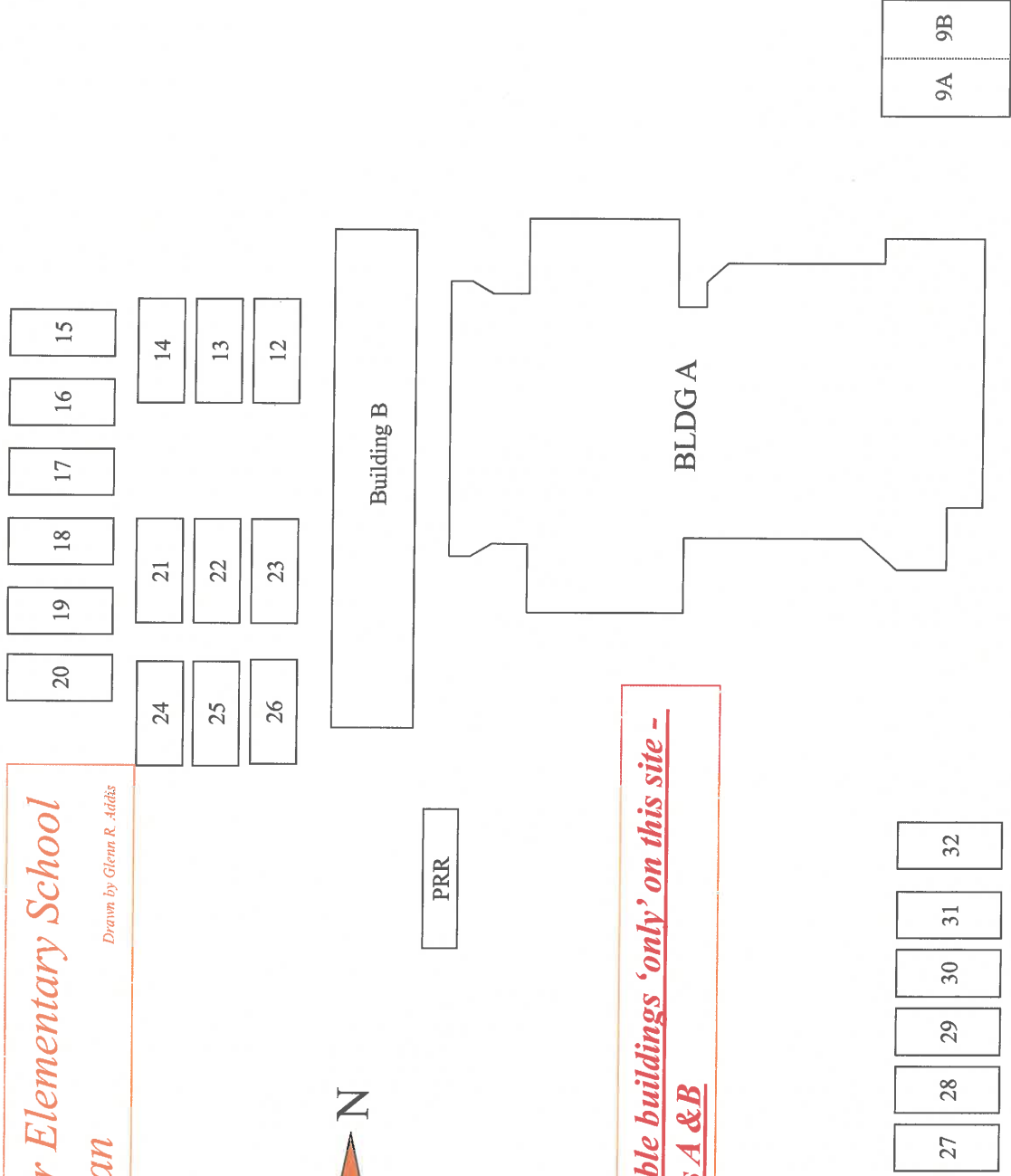

*Yucca Mesa Elementary
Site Plan*
Drawn by Glenn R. Addis

N6

N5

N4

N3

N2

N1

N

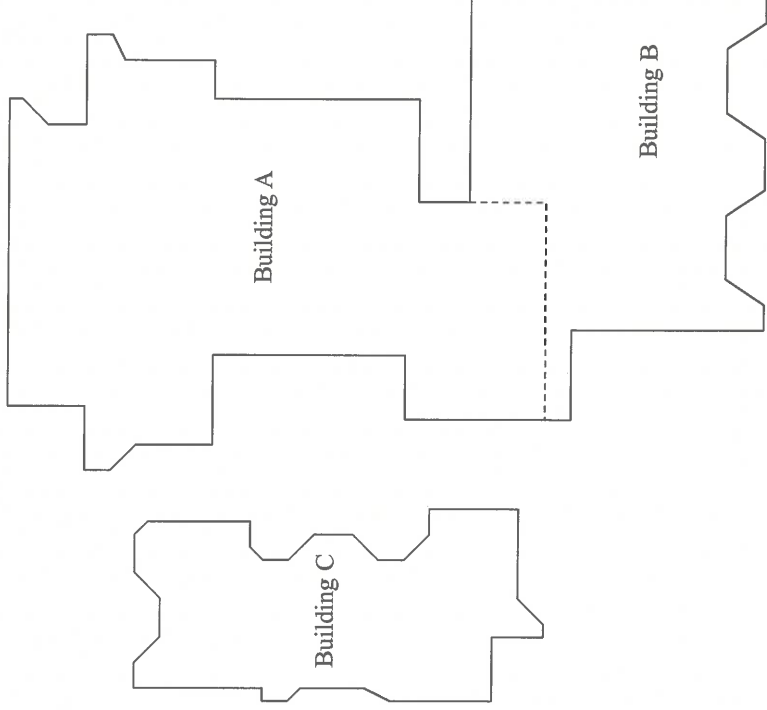

Painting all buildings on this site

S3

S2

S1

Painting all buildings marked 'X'

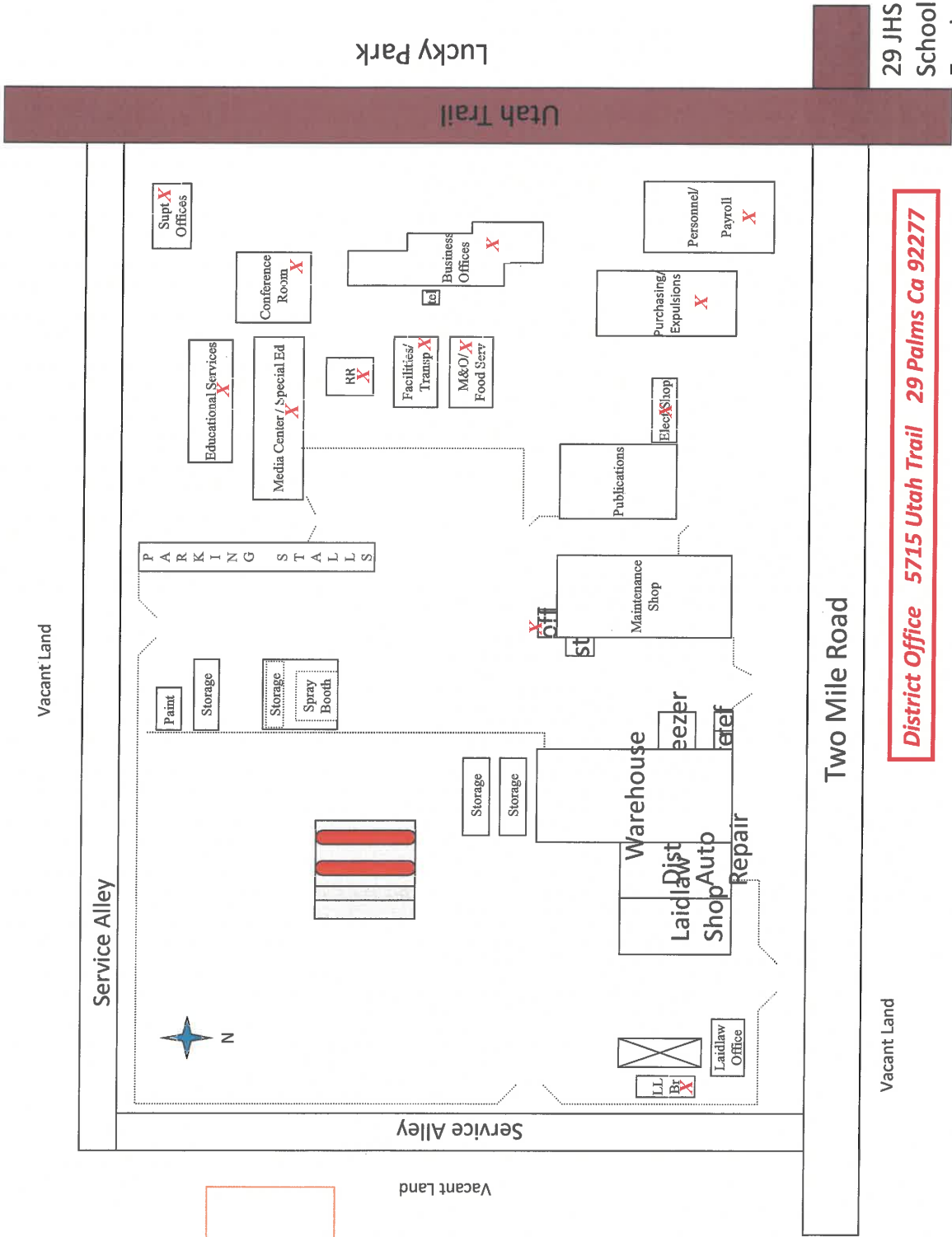

District Office 5715 Utah Trail 29 Palms Ca 92277

29 JHS School

Maintenance Shop
 Coordinates F6
 Upper Level
 Scale: 1" = 10'

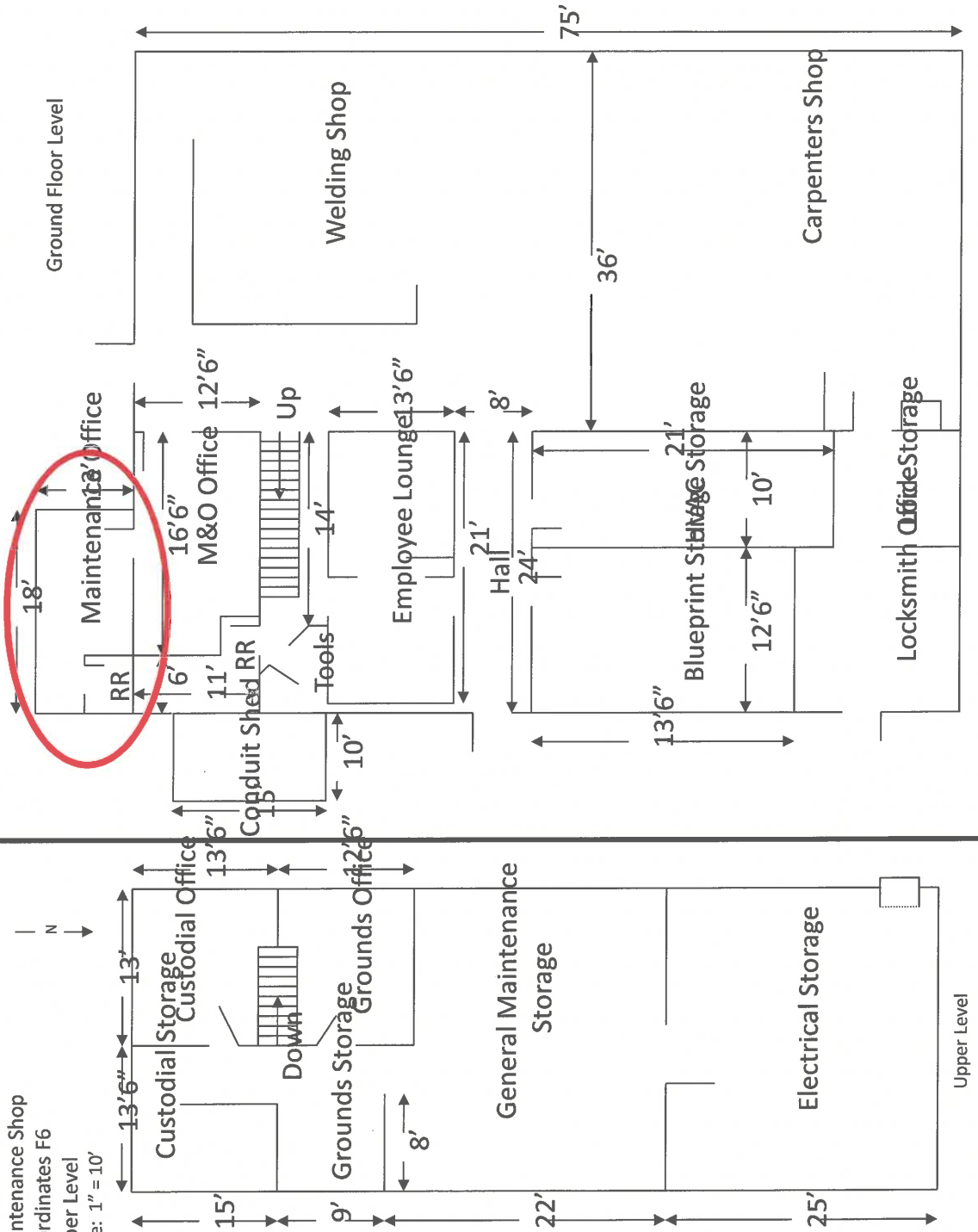

M&O / Food Services
 Facilities/ Transportation
 Scale: 1" = 10'

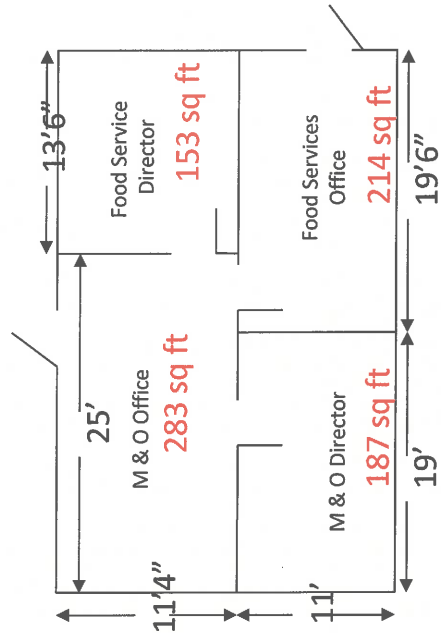
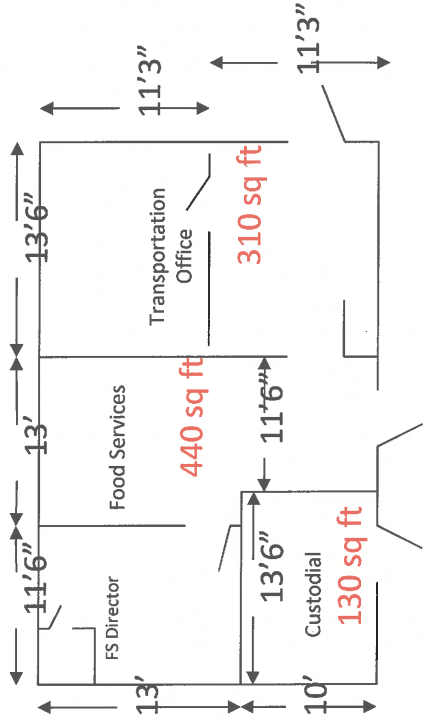

Payroll / Human Resources

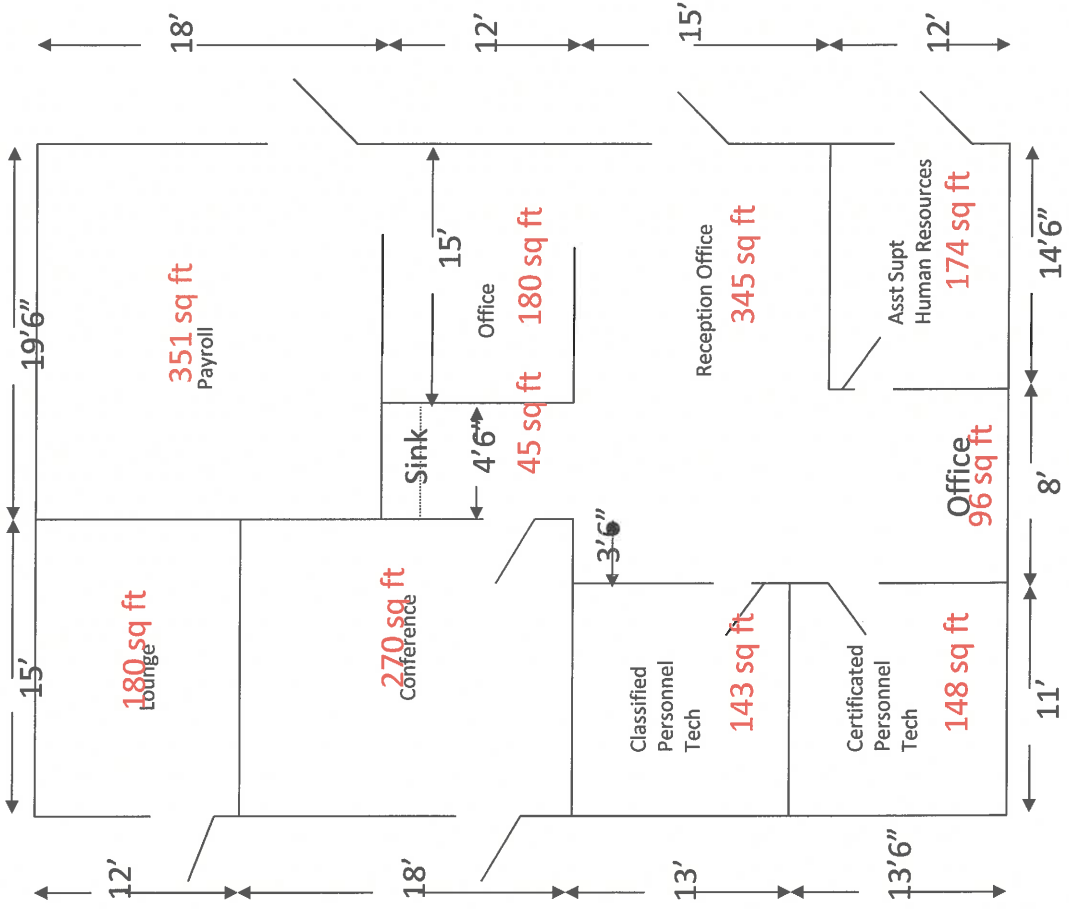
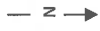

Student Services/
Purchasing/Expulsions

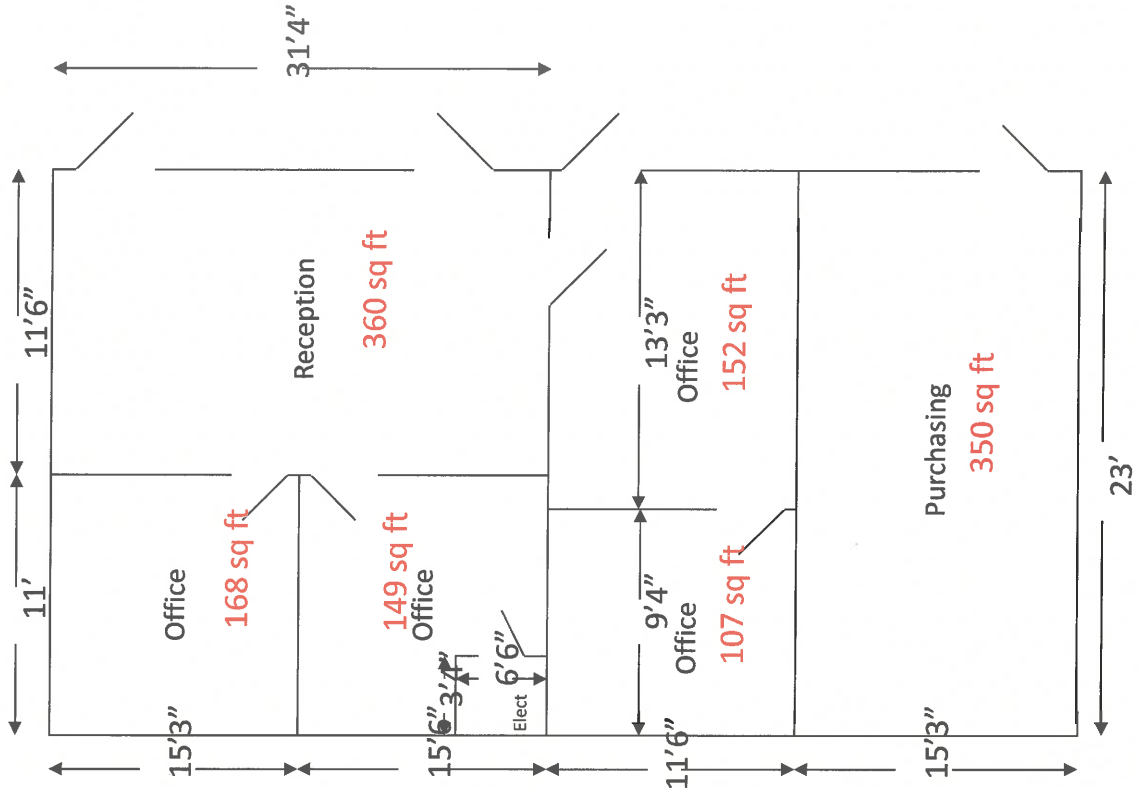

Publications and Electronics

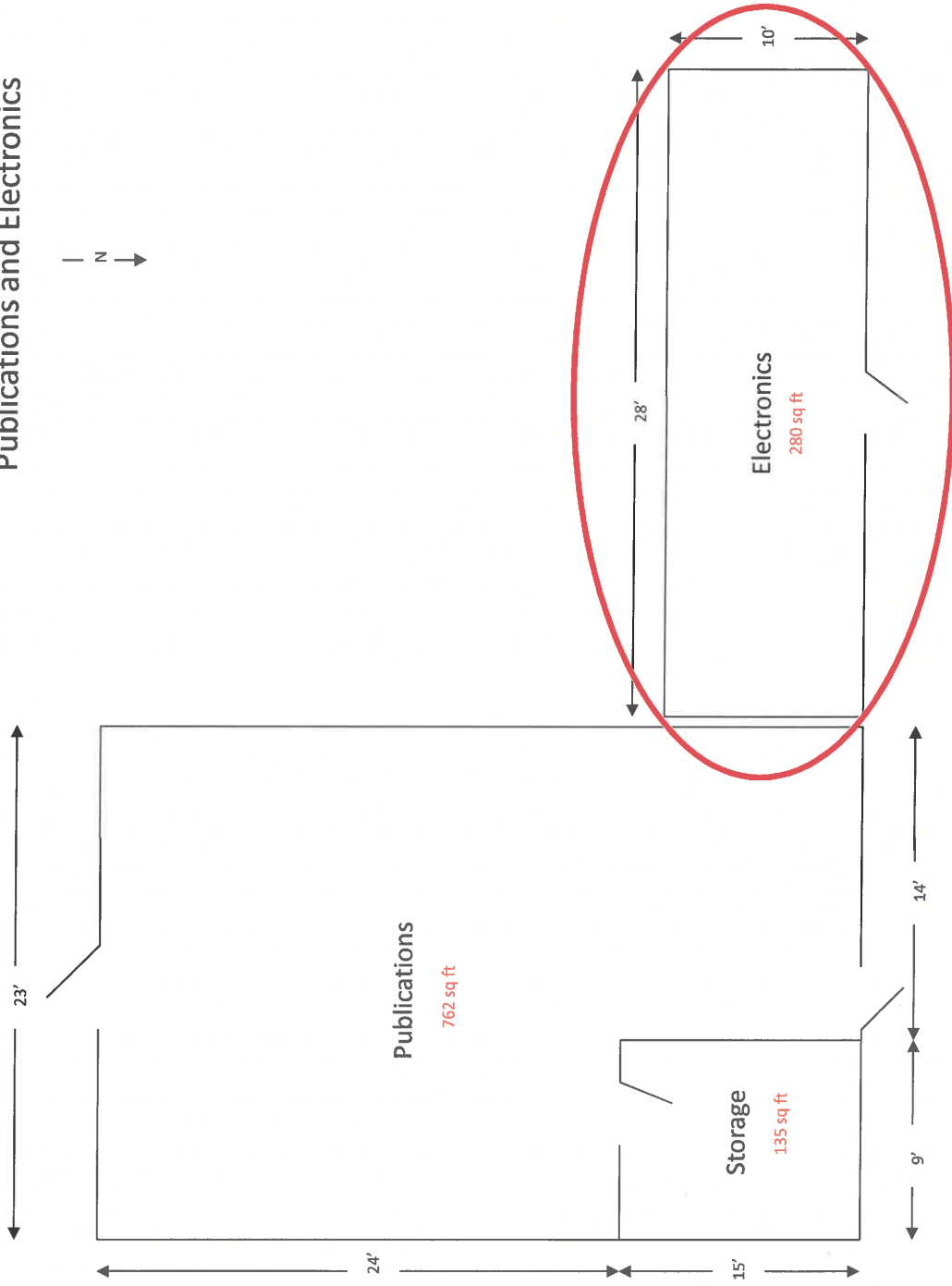
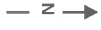

Instructional Services Special Education

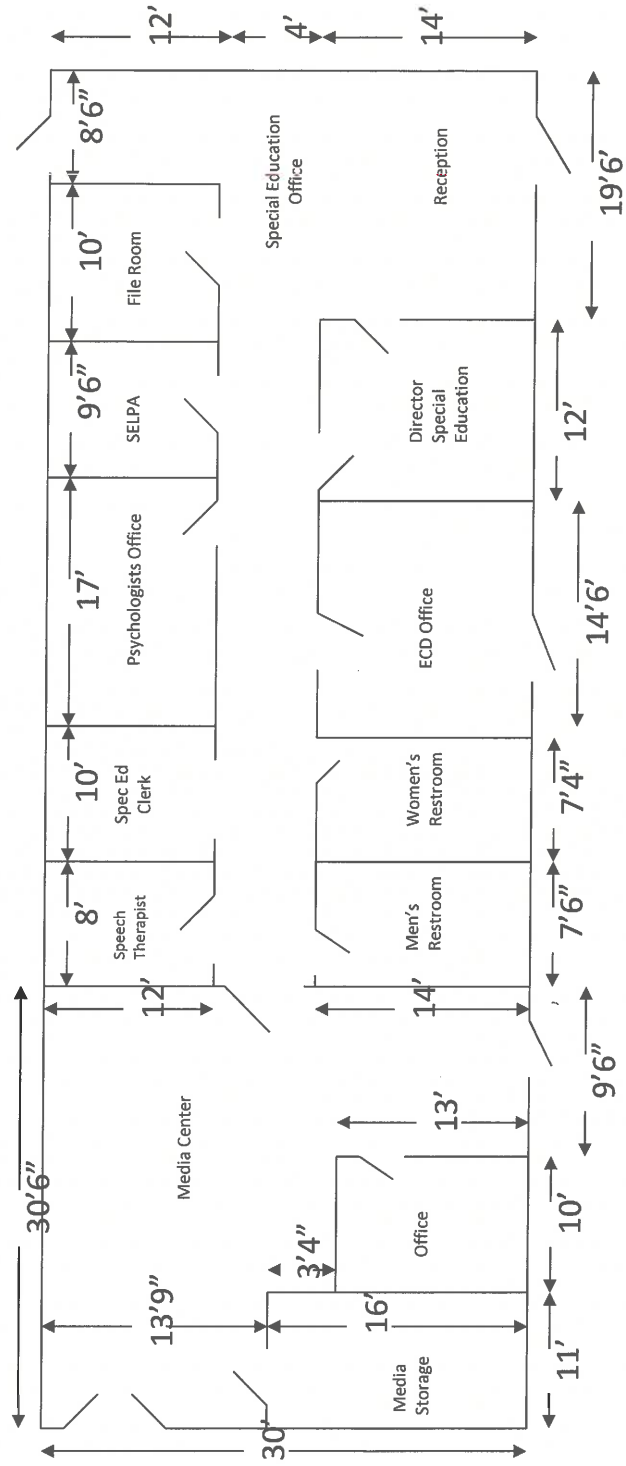
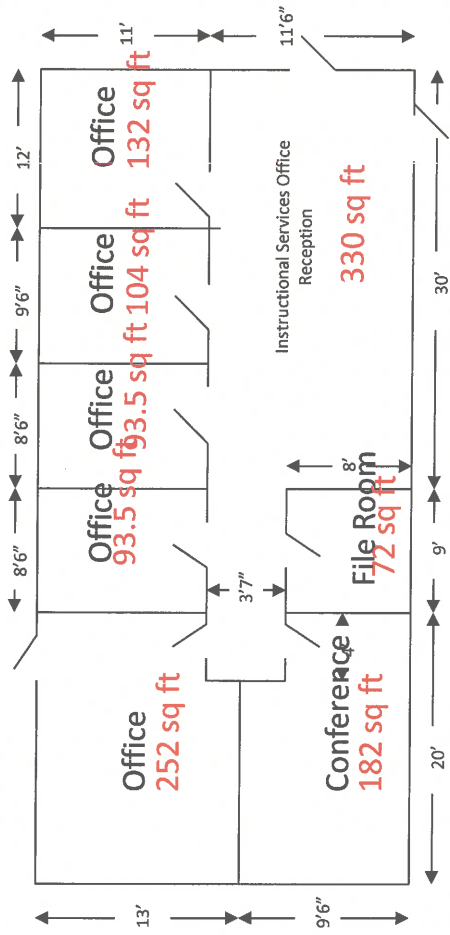

Superintendent's Office Conference Room Buildings

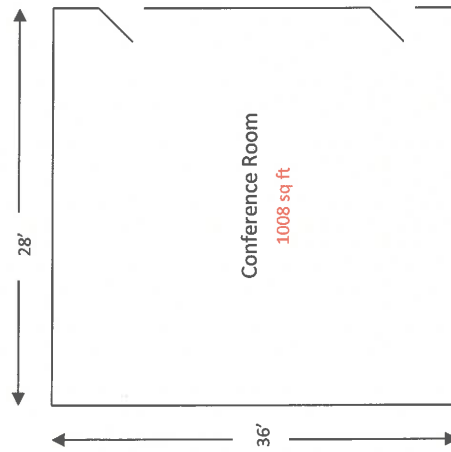
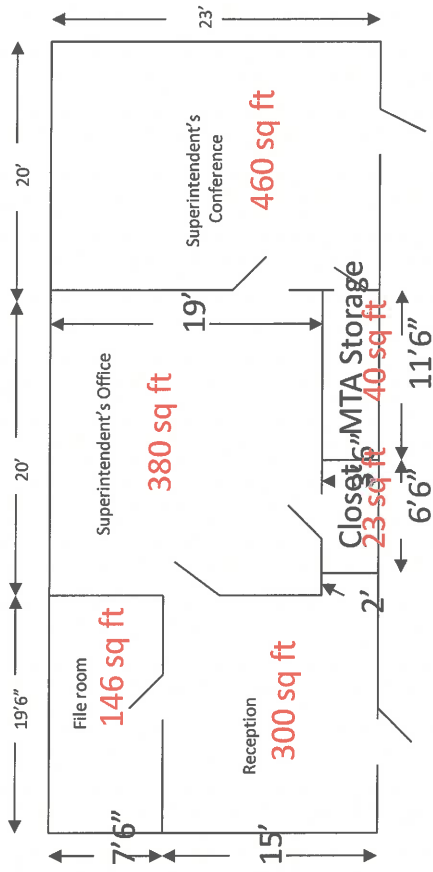

Business Office Building

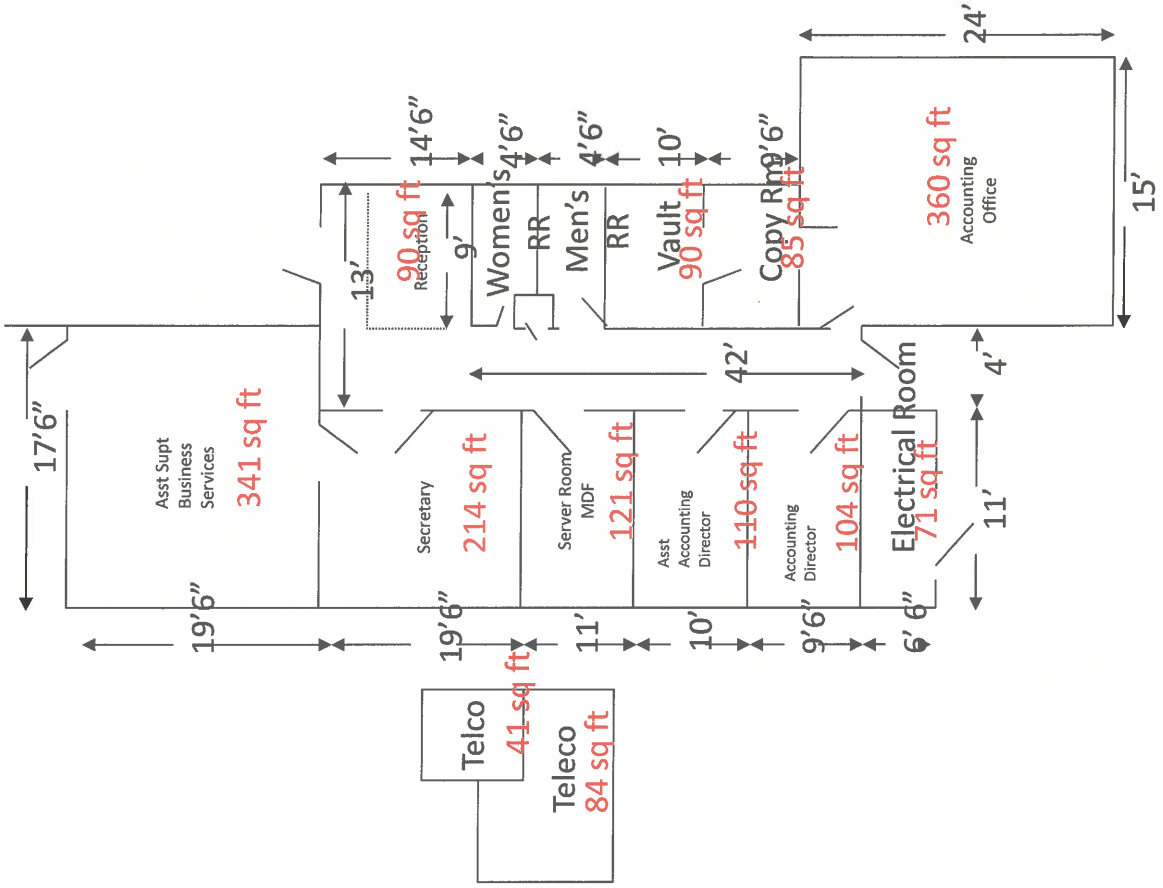

District & Site Maps

BID #19-01

Re-Painting at Three District Sites

**(Condor Elementary School, District Office &
Yucca Mesa Elementary School)**

THE CAMPUSES OF THE MORONGO UNIFIED SCHOOL DISTRICT

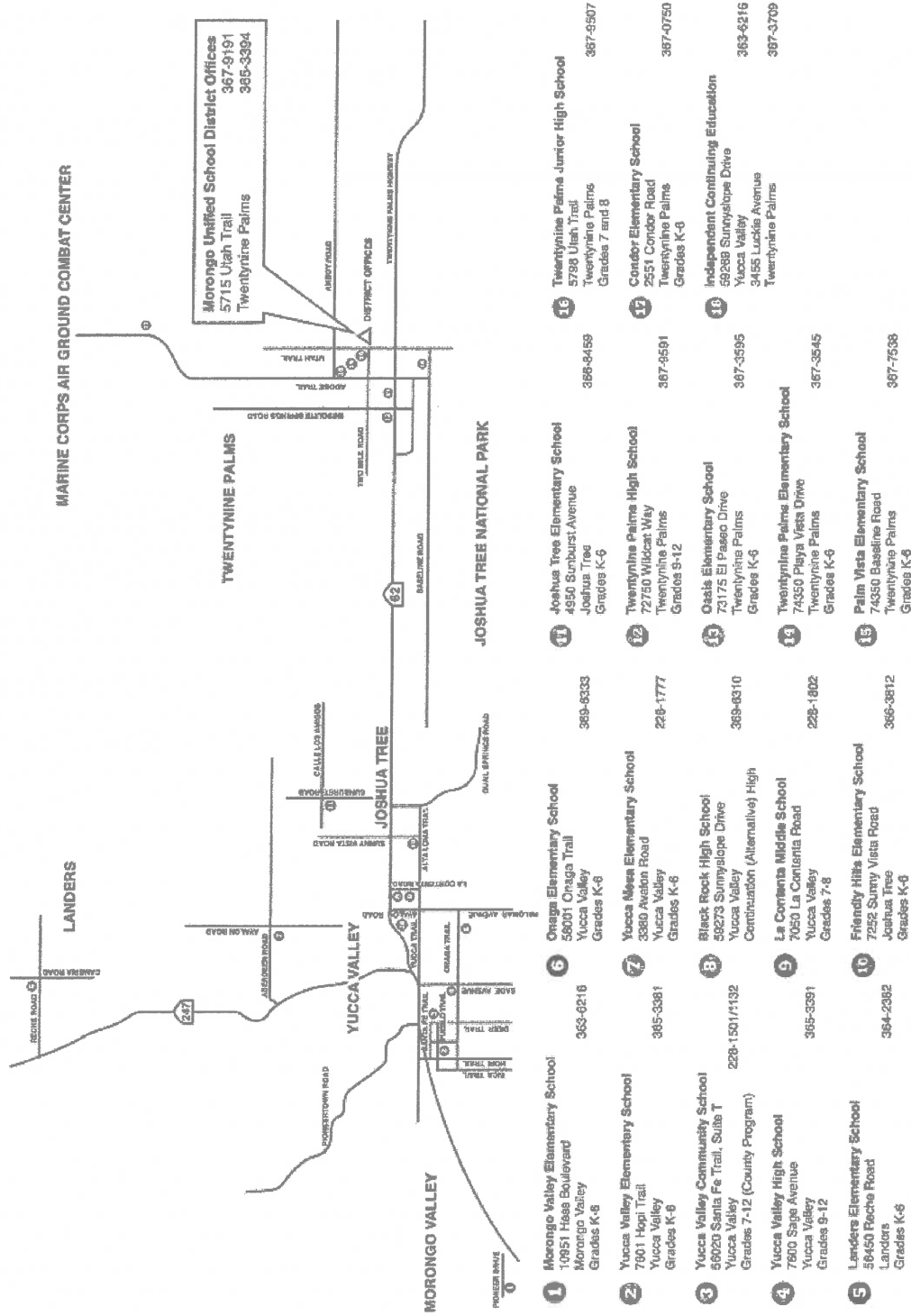



W

©2010 Google

Imagery Date: 12/2/2015

34°12'26.98" N 118°02'29.05" W (elev. 1722 ft)

Eye alt: 3093 ft



District Office

©2010 Google

Imagery Date: 11/2/2015 1995

34.9845475°N 116.020763°W, elev. 1668 ft.

Eye alt: 2452 ft.

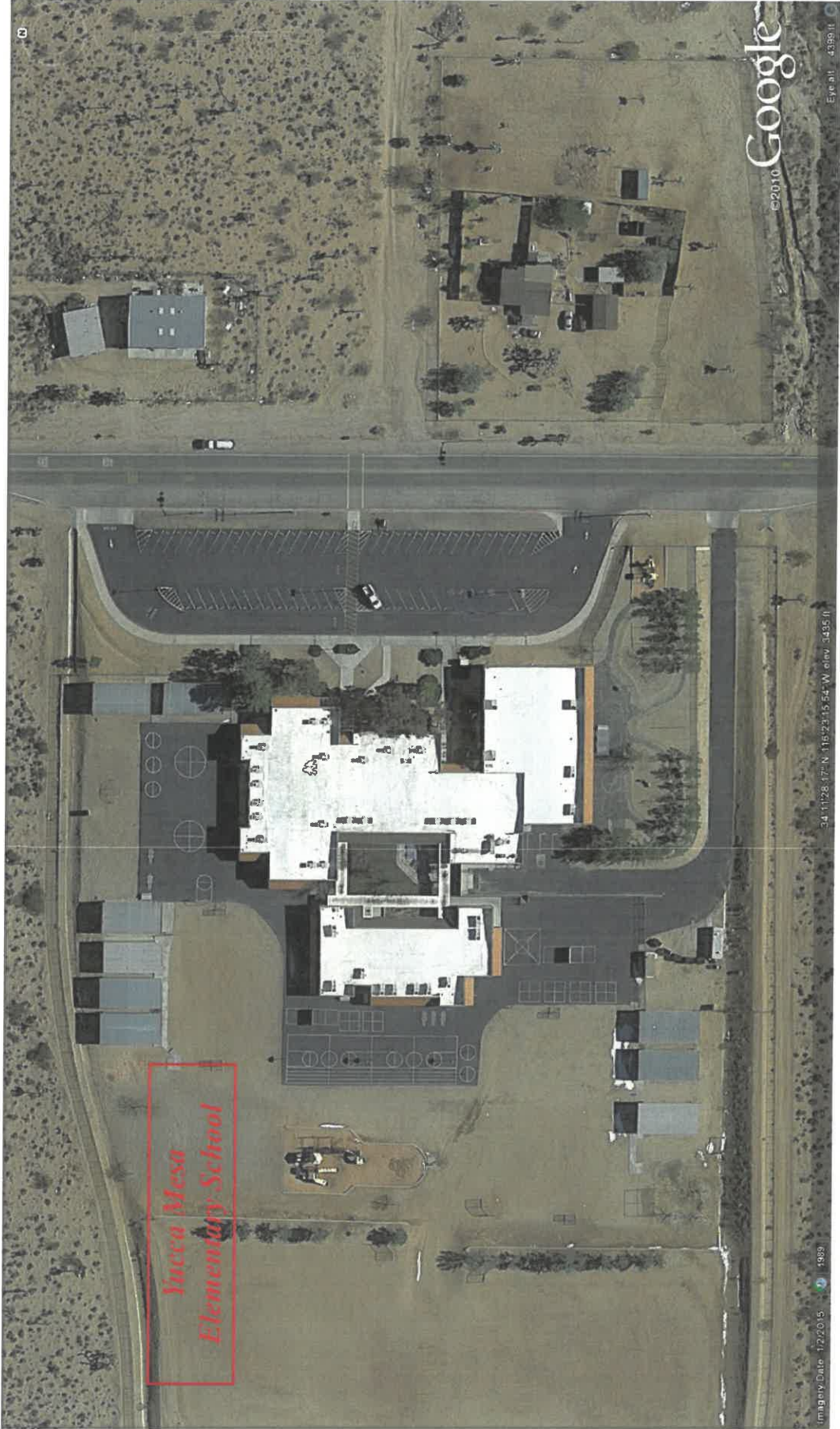

*Yucca Mesa
Elementary School*

Imagery Date: 12/2015 1889

34° 11' 28.177" N 116° 23' 15.54" W elev: 3435 ft

©2010 Google

Eye alt: 4399 ft

8