



## ADDENDUM NO. 1

Issue Date: June 26, 2024

Project Name: Hobart Park Baseball Field Improvements

Bid Number: 2024048

Bid Opening Date: July 17, 2024

This addendum is being released to modify bid documents through the addition of Division 2 Technical Provisions. The information and documents contained in this addendum are hereby incorporated in the invitation to bid. **This addendum must be acknowledged where indicated on the bid form, or the bid may be declared non-responsive.**

### **Modifications to Bid Documents:**

**1. ADD** "Division 2 – Technical Provisions"

**2. MODIFY** Division 0, Section 00520, Article 3-Engineer, paragraph 3.01 as follows:

3.01 ~~The Indian River County Public Works Department~~ Masteller & Moler Inc. is hereinafter called the ENGINEER and will act as OWNER's representative, assume all duties and responsibilities, and have the rights and authority assigned to ENGINEER in the Contract Documents in connection with the completion of the Work in accordance with the Contract Documents.

**3. MODIFY** Division 0, Section 00520, Article 9, Paragraph 9.01.A.11 as follows:

11. Specifications as listed in Division 1 (General Requirements) and Division 2-Technical Provisions

### **Attachments:**

Division 2 – Technical Provisions, consisting of 144 pages

---

## **DIVISION 2 – TECHNICAL PROVISIONS**

---

Remainder of this page is intentionally left blank.

**A NEW CONCESSION BUILDING  
for  
INDIAN RIVER COUNTY  
HOBART PARK**



**Project Manual  
Bid Set**

Project No. 2018.04

March 11, 2024



**Donadio & Associates, Architects**  
**A Spiegle Group Inc. Company**  
2001 9<sup>th</sup> Avenue, Suite 308  
Vero Beach, Florida 32960

# Table of Contents

Division	Section Title	Pages
----------	---------------	-------

## **DIVISION 1 - GENERAL REQUIREMENTS**

01100.....	SUMMARY.....	1
01250.....	CONTRACT MODIFICATION PROCEDURES [DELETED - REFERENCE DIVISION 0]	
01290.....	PAYMENT PROCEDURES [DELETED - REFERENCE DIVISION 0]	
01310.....	PROJECT MANAGEMENT AND COORDINATION.....	4
01320.....	CONSTRUCTION PROGRESS DOCUMENTATION .....	8
01330.....	SUBMITTAL PROCEDURES.....	7
01770.....	CLOSEOUT PROCEDURES.....	4
01781.....	PROJECT RECORD DOCUMENTS.....	4

## **DIVISION 2 - SITE CONSTRUCTION.....SEE CIVIL ENGINEERING DRAWINGS**

02361.....	TERMITE CONTROL .....	4
------------	-----------------------	---

## **DIVISION 3 – CONCRETE.....SEE STRUCTURAL ENGINEERING DRAWINGS**

## **DIVISION 4 - MASONRY.....SEE STRUCTURAL ENGINEERING DRAWINGS**

## **DIVISION 5 – METALS**

NOT APPLICABLE

## **DIVISION 6 - WOOD AND PLASTICS.....SEE STRUCTURAL ENGINEERING DRAWINGS**

## **DIVISION 7 - THERMAL AND MOISTURE PROTECTION**

07210.....	BUILDING INSULATION.....	4
07411.....	METAL ROOF PANELS.....	11
07460 .....	FIBER CEMENT SOFFIT AND TRIM.....	3
07920.....	JOINT SEALANTS.....	10

## **DIVISION 8 - DOORS AND WINDOWS**

08111.....	STANDARD STEEL DOORS AND FRAMES.....	10
08331 .....	OVERHEAD COILING DOORS.....	5
08411.....	ALUMINUM FRAMED STOREFRONT.....	7
08710.....	FINISH HARDWARE.....	6

## **DIVISION 9 – FINISHES**

09220.....	PORTLAND CEMENT PLASTER .....	6
09671.....	RESINOUS FLOORING.....	6
09911.....	EXTERIOR PAINTING.....	6
09912.....	INTERIOR PAINTING.....	9
09960.....	HIGH-PERFORMANCE COATINGS .....	5

## **DIVISION 10 – SPECIALTIES**

10155.....	TOILET COMPARTMENTS.....	3
10520.....	FIRE-PROTECTION SPECIALTIES.....	3
10801.....	TOILET AND BATH ACCESSORIES.....	5

**DIVISION 11 - EQUIPMENT**  
NOT APPLICABLE

**DIVISION 12 - FURNISHINGS**  
NOT APPLICABLE

**DIVISION 13 - SPECIAL CONSTRUCTION**  
NOT APPLICABLE

**DIVISION 14 - CONVEYING SYSTEMS**  
NOT APPLICABLE

**DIVISION 15 – MECHANICAL.....SEE MEP ENGINEERING DRAWINGS**

**DIVISION 16 - ELECTRICAL.....SEE MEP ENGINEERING DRAWINGS**

**STEEL ROLLING DOOR**  
MIAMI-DADE COUNTY PRODUCT CONTROL SECTION NOA  
CORNELL HURRICAN ROLL UP DOOR PLANS WITH SPECIFICATIONS

SECTION 01100 - SUMMARY

PART 1 - GENERAL

1.1 RELATED DOCUMENTS

- A. Drawings and general provisions of the Contract, including General and Supplementary Conditions and other Division 1 Specification Sections, apply to this Section.

1.2 SUMMARY

- A. This Section includes the following:
1. Work covered by the Contract Documents.
  2. Products ordered in advance.

1.3 WORK COVERED BY CONTRACT DOCUMENTS

- A. Project Identification: **INDIAN RIVER COUNTY HOBART PARK CONCESSION BUILDING  
DONADIO & ASSOCIATES PROJECT NO. 2018.04  
A SPIEZLE GROUP INC. COMPANY**

1. Project Location: **5790 77<sup>TH</sup> STREET  
VERO BEACH, FLORIDA 32967**

- B. Owner: **INDIAN RIVER COUNTY BOARD OF COUNTY COMMISSIONERS**

- C. Architect: **DONADIO & ASSOCIATES ARCHITECTS  
A SPIEZLE GROUP INC. COMPANY  
2001 9<sup>TH</sup> AVENUE, SUITE 308  
VERO BEACH, FLORIDA 32960  
772-794-2929 (PH)**

[adonadio@spiezle.com](mailto:adonadio@spiezle.com) (E-MAIL)

- D. The Work consists of the following:
1. The Work includes. The Project involves the Construction of Single Story Concession Building, including the installation of all Civil/Site Work, Architectural, Structural, Electrical and Mechanical work as detailed in the plans and these specifications.

END OF SECTION 01100

## SECTION 01310 - PROJECT MANAGEMENT AND COORDINATION

### PART 1 - GENERAL

#### 1.1 RELATED DOCUMENTS

- A. Drawings and general provisions of the Contract, including General and Supplementary Conditions and other Division 1 Specification Sections, apply to this Section.

#### 1.2 SUMMARY

- A. This Section includes administrative provisions for coordinating construction operations on Project including, but not limited to, the following:
  - 1. Coordination Drawings.
  - 2. Project meetings.
- B. Related Sections include the following:
  - 1. Division 1 Section "Construction Progress Documentation" for preparing and submitting Contractor's Construction Schedule.
  - 2. Division 1 Section "Closeout Procedures" for coordinating Contract closeout.

#### 1.3 COORDINATION

- A. Coordination: Coordinate construction operations included in different Sections of the Specifications to ensure efficient and orderly installation of each part of the Work. Coordinate construction operations, included in different Sections, that depend on each other for proper installation, connection, and operation.
  - 1. Schedule construction operations in sequence required to obtain the best results where installation of one part of the Work depends on installation of other components, before or after its own installation.
  - 2. Coordinate installation of different components with other contractors to ensure maximum accessibility for required maintenance, service, and repair.
  - 3. Make adequate provisions to accommodate items scheduled for later installation.
  - 4. Where availability of space is limited, coordinate installation of different components to ensure maximum performance and accessibility for required maintenance, service, and repair of all components, including mechanical and electrical.
- B. Prepare memoranda for distribution to each party involved, outlining special procedures required for coordination. Include such items as required notices, reports, and list of attendees at meetings.
  - 1. Prepare similar memoranda for Owner and separate contractors if coordination of their Work is required.

- C. Administrative Procedures: Coordinate scheduling and timing of required administrative procedures with other construction activities and activities of other contractors to avoid conflicts and to ensure orderly progress of the Work. Such administrative activities include, but are not limited to, the following:
1. Preparation of Contractor's Construction Schedule.
  2. Preparation of the Schedule of Values.
  3. Installation and removal of temporary facilities and controls.
  4. Delivery and processing of submittals.
  5. Progress meetings.
  6. Preinstallation conferences.
  7. Project closeout activities.
  8. Startup and adjustment of systems.
  9. Project closeout activities.
- D. Conservation: Coordinate construction activities to ensure that operations are carried out with consideration given to conservation of energy, water, and materials.
1. Salvage materials and equipment involved in performance of, but not actually incorporated into, the Work. Refer to other Sections for disposition of salvaged materials that are designated as Owner's property.

#### 1.4 SUBMITTALS

- A. Coordination Drawings: Prepare Coordination Drawings if limited space availability necessitates maximum utilization of space for efficient installation of different components or if coordination is required for installation of products and materials fabricated by separate entities.
1. Content: Project-specific information, drawn accurately to scale. Do not base Coordination Drawings on reproductions of the Contract Documents or standard printed data. Include the following information, as applicable:
    - a. Indicate functional and spatial relationships of components of architectural, structural, civil, mechanical, and electrical systems.
    - b. Indicate required installation sequences.
    - c. Indicate dimensions shown on the Contract Drawings and make specific note of dimensions that appear to be in conflict with submitted equipment and minimum clearance requirements. Provide alternate sketches to Architect for resolution of such conflicts. Minor dimension changes and difficult installations will not be considered changes to the Contract.
  2. Sheet Size: At least 8-1/2 by 11 inches (215 by 280 mm) but no larger than 30 by 40 inches (750 by 1000 mm).
  3. Number of Copies: Submit five opaque copies of each submittal. Architect will return four copies, unless they are engineering submittals, then four copies will be submitted.
    - a. Submit five copies where Coordination Drawings are required for operation and maintenance manuals. Architect will retain two copies; remainder will be returned.
  4. Refer to individual Sections for Coordination Drawing requirements for Work in those Sections.



- B. Key Personnel Names: Within 15 days of starting construction operations, submit a list of key personnel assignments, including superintendent and other personnel in attendance at Project site. Identify individuals and their duties and responsibilities; list addresses and telephone numbers, including home and office telephone numbers. Provide names, addresses, and telephone numbers of individuals assigned as standbys in the absence of individuals assigned to Project.
  - 1. Post copies of list in Project meeting room, in temporary field office, and by each temporary telephone. Keep list current at all times.

## 1.5 PROJECT MEETINGS

- A. General: Schedule and conduct meetings and conferences at Project site, unless otherwise indicated.
  - 1. Attendees: Inform participants and others involved, and individuals whose presence is required, of date and time of each meeting. Notify Owner and Architect of scheduled meeting dates and times.
  - 2. Agenda: Prepare the meeting agenda. Distribute the agenda to all invited attendees.
  - 3. Minutes: Record significant discussions and agreements achieved. Distribute the meeting minutes to everyone concerned, including Owner and Architect, within [three] <Insert number> days of the meeting.
  
- B. Preinstallation Conferences: Conduct a preinstallation conference at Project site before each construction activity that requires coordination with other construction.
  - 1. Attendees: Installer and representatives of manufacturers and fabricators involved in or affected by the installation and its coordination or integration with other materials and installations that have preceded or will follow, shall attend the meeting. Advise Architect of scheduled meeting dates.
  - 2. Agenda: Review progress of other construction activities and preparations for the particular activity under consideration, including requirements for the following:
    - a. The Contract Documents.
    - b. Related requests for interpretations (RFIs).
    - c. Related Change Orders.
    - d. Submittals.
    - e. Review of mockups.
    - f. Time schedules.
    - g. Weather limitations.
    - h. Manufacturer's written recommendations.
    - i. Warranty requirements.
    - j. Compatibility of materials.
    - k. Testing and inspecting requirements.
    - l. Required performance results.
    - m. Protection of adjacent work.
  - 3. Record significant conference discussions, agreements, and disagreements, including required corrective measures and actions.
  - 4. Reporting: Distribute minutes of the meeting to each party present and to parties who should have been present.
  - 5. Do not proceed with installation if the conference cannot be successfully concluded. Initiate whatever actions are necessary to resolve impediments to performance of the Work and reconvene the conference at earliest feasible date.

- C. Progress Meetings: Conduct progress meetings at weekly intervals. Coordinate dates of meetings with preparation of payment requests.
1. Attendees: In addition to representatives of Owner and Architect, each contractor, subcontractor, supplier, and other entity concerned with current progress or involved in planning, coordination, or performance of future activities shall be represented at these meetings. All participants at the conference shall be familiar with Project and authorized to conclude matters relating to the Work.
  2. Agenda: Review and correct or approve minutes of previous progress meeting. Review other items of significance that could affect progress. Include topics for discussion as appropriate to status of Project.
    - a. Contractor's Construction Schedule: Review progress since the last meeting. Determine whether each activity is on time, ahead of schedule, or behind schedule, in relation to Contractor's Construction Schedule. Determine how construction behind schedule will be expedited; secure commitments from parties involved to do so. Discuss whether schedule revisions are required to ensure that current and subsequent activities will be completed within the Contract Time.
      - 1) Review schedule for next period.
    - b. Review present and future needs of each entity present, including the following:
      - 1) Interface requirements.
      - 2) Status of submittals.
      - 3) Work hours.
      - 4) Quality and work standards.
      - 5) Status of correction of deficient items.
      - 6) Field observations.
      - 7) Requests for interpretations (RFIs).
      - 8) Status of proposal requests.
      - 9) Pending changes.
      - 10) Status of Change Orders.
      - 11) Pending claims and disputes.
      - 12) Documentation of information for payment requests.
  3. Minutes: Architect will record and distribute to Contractor the meeting minutes.
  4. Reporting: Distribute minutes of the meeting to each party present and to parties who should have been present.
    - a. Schedule Updating: Revise Contractor's Construction Schedule after each progress meeting where revisions to the schedule have been made or recognized. Issue revised schedule concurrently with the report of each meeting.

END OF SECTION 01310

## SECTION 01320 - CONSTRUCTION PROGRESS DOCUMENTATION

### PART 1 - GENERAL

#### 1.1 RELATED DOCUMENTS

- A. Drawings and general provisions of the Contract, including General and Supplementary Conditions and other Division 1 Specification Sections, apply to this Section.

#### 1.2 SUMMARY

- A. This Section includes administrative and procedural requirements for documenting the progress of construction during performance of the Work, including the following:
  - 1. Preliminary Construction Schedule.
  - 2. Contractor's Construction Schedule.
  - 3. Submittals Schedule.
  - 4. Daily construction reports.
  - 5. Field condition reports.
- B. Related Sections include the following:
  - 1. Division 1 Section "Payment Procedures" for submitting the Schedule of Values.
  - 2. Division 1 Section "Project Management and Coordination" for submitting and distributing meeting and conference minutes.
  - 3. Division 1 Section "Submittal Procedures" for submitting schedules and reports.

#### 1.3 DEFINITIONS

- A. Activity: A discrete part of a project that can be identified for planning, scheduling, monitoring, and controlling the construction project. Activities included in a construction schedule consume time and resources.
  - 1. Critical activities are activities on the critical path. They must start and finish on the planned early start and finish times.
  - 2. Predecessor Activity: An activity that precedes another activity in the network.
  - 3. Successor Activity: An activity that follows another activity in the network.
- B. Cost Loading: The allocation of the Schedule of Values for the completion of an activity as scheduled. The sum of costs for all activities must equal the total Contract Sum, unless otherwise approved by Architect.
- C. CPM: Critical path method, which is a method of planning and scheduling a construction project where activities are arranged based on activity relationships. Network calculations determine when activities can be performed and the critical path of Project.
- D. Critical Path: The longest connected chain of interdependent activities through the network schedule that establishes the minimum overall Project duration and contains no float.

- E. Event: The starting or ending point of an activity.
- F. Float: The measure of leeway in starting and completing an activity.
  - 1. Float time belongs to Owner.
  - 2. Free float is the amount of time an activity can be delayed without adversely affecting the early start of the successor activity.
  - 3. Total float is the measure of leeway in starting or completing an activity without adversely affecting the planned Project completion date.
- G. Fragnet: A partial or fragmentary network that breaks down activities into smaller activities for greater detail.
- H. Major Area: A story of construction, a separate building, or a similar significant construction element.
- I. Milestone: A key or critical point in time for reference or measurement.
- J. Network Diagram: A graphic diagram of a network schedule, showing activities and activity relationships.
- K. Resource Loading: The allocation of manpower and equipment necessary for the completion of an activity as scheduled.

#### 1.4 SUBMITTALS

- A. Submittals Schedule: Submit three copies of schedule. Arrange the following information in a tabular format:
  - 1. Scheduled date for first submittal.
  - 2. Specification Section number and title.
  - 3. Submittal category (action or informational).
  - 4. Name of subcontractor.
  - 5. Description of the Work covered.
  - 6. Scheduled date for Architect's final release or approval.
- B. Preliminary Construction Schedule: Submit three opaque copies.
  - 1. Approval of cost-loaded preliminary construction schedule will not constitute approval of Schedule of Values for cost-loaded activities.
- C. Contractor's Construction Schedule: Submit three opaque copies of initial schedule, large enough to show entire schedule for entire construction period.
  - 1. Submit an electronic copy of schedule, using software indicated, on CD-R, and labeled to comply with requirements for submittals. Include type of schedule (Initial or Updated) and date on label.

- D. CPM Reports: Concurrent with CPM schedule, submit three copies of each of the following computer-generated reports. Format for each activity in reports shall contain activity number, activity description, cost and resource loading, original duration, remaining duration, early start date, early finish date, late start date, late finish date, and total float in calendar days.
  - 1. Activity Report: List of all activities sorted by activity number and then early start date, or actual start date if known.
  - 2. Logic Report: List of preceding and succeeding activities for all activities, sorted in ascending order by activity number and then early start date, or actual start date if known.
  - 3. Total Float Report: List of all activities sorted in ascending order of total float.
- E. Daily Construction Reports: Submit two copies at weekly intervals.
- F. Field Condition Reports: Submit two copies at time of discovery of differing conditions.

## 1.5 COORDINATION

- A. Coordinate preparation and processing of schedules and reports with performance of construction activities and with scheduling and reporting of separate contractors.
- B. Coordinate Contractor's Construction Schedule with the Schedule of Values, list of subcontracts, Submittals Schedule, progress reports, payment requests, and other required schedules and reports.
  - 1. Secure time commitments for performing critical elements of the Work from parties involved.
  - 2. Coordinate each construction activity in the network with other activities and schedule them in proper sequence.

## PART 2 - PRODUCTS

### 2.1 SUBMITTALS SCHEDULE

- A. Preparation: Submit a schedule of submittals, arranged in chronological order by dates required by construction schedule. Include time required for review, resubmittal, ordering, manufacturing, fabrication, and delivery when establishing dates.
  - 1. Coordinate Submittals Schedule with list of subcontracts, the Schedule of Values, and Contractor's Construction Schedule.
  - 2. Final Submittal: Submit concurrently with the first complete submittal of Contractor's Construction Schedule.

### 2.2 CONTRACTOR'S CONSTRUCTION SCHEDULE, GENERAL

- A. Procedures: Comply with procedures contained in AGC's "Construction Planning & Scheduling."
- B. Time Frame: Extend schedule from date established for commencement of the Work to date of Completion.
  - 1. Contract completion date shall not be changed by submission of a schedule that shows an early completion date, unless specifically authorized by Change Order.

- C. Activities: Treat each story or separate area as a separate numbered activity for each principal element of the Work. Comply with the following:
1. Activity Duration: Define activities so no activity is longer than 20 days, unless specifically allowed by Architect.
  2. Procurement Activities: Include procurement process activities for the following long lead items and major items, requiring a cycle of more than 60 days, as separate activities in schedule. Procurement cycle activities include, but are not limited to, submittals, approvals, purchasing, fabrication, and delivery.
  3. Submittal Review Time: Include review and resubmittal times indicated in Division 1 Section "Submittal Procedures" in schedule. Coordinate submittal review times in Contractor's Construction Schedule with Submittals Schedule.
  4. Startup and Testing Time: Include not less than five days for startup and testing.
  5. Substantial Completion: Indicate completion in advance of date established for Substantial Completion, and allow time for Architect's administrative procedures necessary for certification of Substantial Completion.
- D. Constraints: Include constraints and work restrictions indicated in the Contract Documents and as follows in schedule, and show how the sequence of the Work is affected.
1. Phasing: Arrange list of activities on schedule by phase.
  2. Products Ordered in Advance: Include a separate activity for each product. Include delivery date indicated in Division 1 Section "Summary." Delivery dates indicated stipulate the earliest possible delivery date.
  3. Work Restrictions: Show the effect of the following items on the schedule:
    - a. Seasonal variations.
    - b. Environmental control.
  4. Work Stages: Indicate important stages of construction for each major portion of the Work, including, but not limited to, the following:
    - a. Subcontract awards.
    - b. Submittals.
    - c. Purchases.
    - d. Installation.
    - e. Tests and inspections.
    - f. Startup and placement into final use and operation.
  5. Area Separations: Identify each major area of construction for each major portion of the Work. Indicate where each construction activity within a major area must be sequenced or integrated with other construction activities to provide for the following:
    - a. Structural completion.
    - b. Permanent space enclosure.
    - c. Completion of mechanical installation.
    - d. Completion of electrical installation.
    - e. Substantial Completion.
- E. Milestones: Include milestones indicated in the Contract Documents in schedule, including, but not limited to, the Notice to Proceed, Substantial Completion, and Final Completion

- F. Cost Correlation: At the head of schedule, provide a cost correlation line, indicating planned and actual costs. On the line, show dollar volume of the Work performed as of dates used for preparation of payment requests.
1. Refer to Division 1 Section "Payment Procedures" for cost reporting and payment procedures.
  2. Contractor shall assign cost to construction activities on the CPM schedule. Costs shall not be assigned to submittal activities unless specified otherwise but may, with Architect's approval, be assigned to fabrication and delivery activities. Costs shall be under required principal subcontracts for testing and commissioning activities, operation and maintenance manuals, punch list activities, Project Record Documents, and demonstration and training (if applicable), in the amount of 5 percent of the Contract Sum.
  3. Each activity cost shall reflect an accurate value subject to approval by Architect.
  4. Total cost assigned to activities shall equal the total Contract Sum.
- G. Contract Modifications: For each proposed contract modification and concurrent with its submission, prepare a time-impact analysis using fragnets to demonstrate the effect of the proposed change on the overall project schedule.

### 2.3 PRELIMINARY CONSTRUCTION SCHEDULE

- A. Bar-Chart Schedule: Submit preliminary horizontal bar-chart-type construction schedule within seven days of date established for commencement of the Work.
- B. Preparation: Indicate each significant construction activity separately. Identify first workday of each week with a continuous vertical line. Outline significant construction activities for first 60 days of construction. Include skeleton diagram for the remainder of the Work and a cash requirement prediction based on indicated activities.

### 2.4 CONTRACTOR'S CONSTRUCTION SCHEDULE (CPM SCHEDULE)

- A. General: Prepare network diagrams using AON (activity-on-node) format.
- B. CPM Schedule: Prepare Contractor's Construction Schedule using a computerized, time-scaled CPM network analysis diagram for the Work.
1. Develop network diagram in sufficient time to submit CPM schedule so it can be accepted for use no later than 30 days after date established for commencement of the Work.
    - a. Failure to include any work item required for performance of this Contract shall not excuse Contractor from completing all work within applicable completion dates, regardless of Architect's approval of the schedule.
  2. Conduct educational workshops to train and inform key Project personnel, including subcontractors' personnel, in proper methods of providing data and using CPM schedule information.
  3. Establish procedures for monitoring and updating CPM schedule and for reporting progress. Coordinate procedures with progress meeting and payment request dates.
  4. Use "one workday" as the unit of time. Include list of nonworking days and holidays incorporated into the schedule.

- C. CPM Schedule Preparation: Prepare a list of all activities required to complete the Work. Using the preliminary network diagram, prepare a skeleton network to identify probable critical paths.
1. Activities: Indicate the estimated time duration, sequence requirements, and relationship of each activity in relation to other activities. Include estimated time frames for the following activities:
    - a. Preparation and processing of submittals.
    - b. Installation.
    - c. Testing.
  2. Critical Path Activities: Identify critical path activities, including those for interim completion dates. Scheduled start and completion dates shall be consistent with Contract milestone dates.
  3. Processing: Process data to produce output data on a computer-drawn, time-scaled network. Revise data, reorganize activity sequences, and reproduce as often as necessary to produce the CPM schedule within the limitations of the Contract Time.
  4. Format: Mark the critical path. Locate the critical path near center of network; locate paths with most float near the edges.
    - a. Sub networks on separate sheets are permissible for activities clearly off the critical path.
- D. Initial Issue of Schedule: Prepare initial network diagram from a list of straight "early start-total float" sort. Identify critical activities. Prepare tabulated reports showing the following:
1. Contractor or subcontractor and the Work or activity.
  2. Description of activity.
  3. Principal events of activity.
  4. Immediate preceding and succeeding activities.
  5. Early and late start dates.
  6. Early and late finish dates.
  7. Activity duration in workdays.
  8. Total float or slack time.
  9. Average size of workforce.
  10. Dollar value of activity (coordinated with the Schedule of Values).
- E. Schedule Updating: Concurrent with making revisions to schedule, prepare tabulated reports showing the following:
1. Identification of activities that have changed.
  2. Changes in early and late start dates.
  3. Changes in early and late finish dates.
  4. Changes in activity durations in workdays.
  5. Changes in the critical path.
  6. Changes in total float or slack time.
  7. Changes in the Contract Time.



- F. Value Summaries: Prepare two cumulative value lists, sorted by finish dates.
1. In first list, tabulate activity number, early finish date, dollar value, and cumulative dollar value.
  2. In second list, tabulate activity number, late finish date, dollar value, and cumulative dollar value.
  3. In subsequent issues of both lists, substitute actual finish dates for activities completed as of list date.
  4. Prepare list for ease of comparison with payment requests; coordinate timing with progress meetings.
    - a. In both value summary lists, tabulate "actual percent complete" and "cumulative value completed" with total at bottom.
    - b. Submit value summary printouts one week before each regularly scheduled progress meeting.

## 2.5 REPORTS

- A. Daily Construction Reports: Prepare a daily construction report recording the following information concerning events at Project site:
1. List of subcontractors at Project site.
  2. List of separate contractors at Project site.
  3. Approximate count of personnel at Project site.
  4. Equipment at Project site.
  5. Material deliveries.
  6. High and low temperatures and general weather conditions.
  7. Stoppages, delays, shortages, and losses.
  8. Meter readings and similar recordings.
  9. Emergency procedures.
  10. Equipment or system tests and startups.
  11. Substantial Completions authorized.
- B. Field Condition Reports: Immediately on discovery of a difference between field conditions and the Contract Documents, prepare and submit a detailed report. Submit with a request for interpretation. Include a detailed description of the differing conditions, together with recommendations for changing the Contract Documents.

## PART 3 - EXECUTION

### 3.1 CONTRACTOR'S CONSTRUCTION SCHEDULE

- A. Contractor's Construction Schedule Updating: At monthly intervals, update schedule to reflect actual construction progress and activities. Issue schedule one week before each regularly scheduled progress meeting.
1. Revise schedule immediately after each meeting or other activity where revisions have been recognized or made. Issue updated schedule concurrently with the report of each such meeting.
  2. Include a report with updated schedule that indicates every change, including, but not limited to, changes in logic, durations, actual starts and finishes, and activity durations.
  3. As the Work progresses, indicate Actual Completion percentage for each activity.

- B. Distribution: Distribute copies of approved schedule to Architect Owner, separate contractors, testing and inspecting agencies, and other parties identified by Contractor with a need-to-know schedule responsibility.
1. Post copies in Project meeting rooms and temporary field offices.
  2. When revisions are made, distribute updated schedules to the same parties and post in the same locations. Delete parties from distribution when they have completed their assigned portion of the Work and are no longer involved in performance of construction activities.

END OF SECTION 01320

## SECTION 01330 - SUBMITTAL PROCEDURES

### PART 1 - GENERAL

#### 1.1 RELATED DOCUMENTS

- A. Drawings and general provisions of the Contract, including General and Supplementary Conditions and other Division 1 Specification Sections, apply to this Section.

#### 1.2 SUMMARY

- A. This Section includes administrative and procedural requirements for submitting Shop Drawings, Product Data, Samples, and other submittals.
- B. Related Sections include the following:
  - 1. Division 1 Section "Payment Procedures" for submitting Applications for Payment and the Schedule of Values.
  - 2. Division 1 Section "Project Management and Coordination" for submitting and distributing meeting and conference minutes and for submitting Coordination Drawings.
  - 3. Division 1 Section "Construction Progress Documentation" for submitting schedules and reports, including Contractor's Construction Schedule and the Submittals Schedule.
  - 4. Division 1 Section "Closeout Procedures" for submitting warranties.
  - 5. Division 1 Section "Project Record Documents" for submitting Record Drawings, Record Specifications, and Record Product Data.
  - 6. Divisions 2 through 16 Sections and Construction Drawings for specific requirements for submittals in those Sections.

#### 1.3 DEFINITIONS

- A. Action Submittals: Written and graphic information that requires Architect's responsive action.
- B. Informational Submittals: Written information that does not require Architect's responsive action. Submittals may be rejected for not complying with requirements.

#### 1.4 SUBMITTAL PROCEDURES

- A. General: Electronic copies of CAD Drawings of the Contract Drawings will[ **not**] be provided by Architect for Contractor's use in preparing submittals.
- B. Coordination: Coordinate preparation and processing of submittals with performance of construction activities.
  - 1. Coordinate each submittal with fabrication, purchasing, testing, delivery, other submittals, and related activities that require sequential activity.

2. Coordinate transmittal of different types of submittals for related parts of the Work so processing will not be delayed because of need to review submittals concurrently for coordination.
  - a. Architect reserves the right to withhold action on a submittal requiring coordination with other submittals until related submittals are received.
- C. Submittals Schedule: Comply with requirements in Division 1 Section "Construction Progress Documentation" for list of submittals and time requirements for scheduled performance of related construction activities.
- D. Processing Time: Allow enough time for submittal review, including time for resubmittals, as follows. Time for review shall commence on Architect's receipt of submittal. No extension of the Contract Time will be authorized because of failure to transmit submittals enough in advance of the Work to permit processing, including resubmittals.
  1. Initial Review: Allow 10 days for initial review of each submittal. Allow additional time if coordination with subsequent submittals is required. Architect will advise Contractor when a submittal being processed must be delayed for coordination.
  2. Intermediate Review: If intermediate submittal is necessary, process it in same manner as initial submittal.
  3. Resubmittal Review: Allow 10 days for review of each resubmittal.
  4. Concurrent Consultant Review: Where the Contract Documents indicate that submittals may be transmitted simultaneously to Architect and to Architect's consultants, allow 10 days for review of each submittal. Submittal will be returned to Architect before being returned to Contractor.
- E. Identification: Place a permanent label or title block on each submittal for identification.
  1. Indicate name of firm or entity that prepared each submittal on label or title block.
  2. Provide a space approximately **6 by 8 inches (150 by 200 mm)** on label or beside title block to record Contractor's review and approval markings and action taken by Architect.
  3. Include the following information on label for processing and recording action taken:
    - a. Project name.
    - b. Date.
    - c. Name and address of Architect.
    - d. Name and address of Contractor.
    - e. Name and address of subcontractor.
    - f. Name and address of supplier.
    - g. Name of manufacturer.
    - h. Submittal number or other unique identifier, including revision identifier.
      - 1) Submittal number shall use Specification Section number followed by a decimal point and then a sequential number (e.g., 06100.01). Resubmittals shall include an alphabetic suffix after another decimal point (e.g., 06100.01.A).
    - i. Number and title of appropriate Specification Section.
    - j. Drawing number and detail references, as appropriate.
    - k. Location(s) where product is to be installed, as appropriate.
    - l. Other necessary identification.
- F. Deviations: Highlight, encircle, or otherwise specifically identify deviations from the Contract Documents on submittals.

- G. Additional Copies: Unless additional copies are required for final submittal, and unless Architect observes noncompliance with provisions in the Contract Documents, initial submittal may serve as final submittal.
1. Submit one copy of submittal to concurrent reviewer in addition to specified number of copies to Architect.
  2. Additional copies submitted for maintenance manuals will be marked with action taken and will be returned.
- H. Transmittal: Package each submittal individually and appropriately for transmittal and handling. Transmit each submittal using a transmittal form. Architect will return submittals, without review, received from sources other than Contractor.
1. Transmittal Form: Use AIA Document G810.
  2. On an attached separate sheet, prepared on Contractor's letterhead, record relevant information, requests for data, revisions other than those requested by Architect on previous submittals, and deviations from requirements in the Contract Documents, including minor variations and limitations. Include same label information as related submittal.
- I. Resubmittals: Make resubmittals in same form and number of copies as initial submittal.
1. Note date and content of previous submittal.
  2. Note date and content of revision in label or title block and clearly indicate extent of revision.
  3. Resubmit submittals until they are marked "**REVIEWED AS NOTED, NO EXCEPTIONS TAKEN**".
- J. Distribution: Furnish copies of final submittals to manufacturers, subcontractors, suppliers, fabricators, installers, authorities having jurisdiction, and others as necessary for performance of construction activities. Show distribution on transmittal forms.
- K. Use for Construction: Use only final submittals with mark indicating "**REVIEWED AS NOTED, NO EXCEPTIONS TAKEN**" taken by Architect.

## PART 2 - PRODUCTS

### 2.1 ACTION SUBMITTALS

- A. General: Prepare and submit Action Submittals required by individual Specification Sections.
1. Submit electronic submittals directly to extranet specifically established for Project.
- B. Product Data: Collect information into a single submittal for each element of construction and type of product or equipment.
1. If information must be specially prepared for submittal because standard printed data are not suitable for use, submit as Shop Drawings, not as Product Data.
  2. Mark each copy of each submittal to show which products and options are applicable.

3. Include the following information, as applicable:
    - a. Manufacturer's written recommendations.
    - b. Manufacturer's product specifications.
    - c. Manufacturer's installation instructions.
    - d. Standard color charts.
    - e. Manufacturer's catalog cuts.
    - f. Wiring diagrams showing factory-installed wiring.
    - g. Printed performance curves.
    - h. Standard product operation and maintenance manuals.
    - i. Testing by recognized testing agency.
  4. Submit Product Data before or concurrent with Samples.
  5. Number of Copies: Submit five copies of Product Data, unless otherwise indicated. Architect will return four copies, unless it is an Engineering submittal, then three copies will be returned.
- C. Shop Drawings: Prepare Project-specific information, drawn accurately to scale. Do not base Shop Drawings on reproductions of the Contract Documents or standard printed data.
1. Preparation: Fully illustrate requirements in the Contract Documents. Include the following information, as applicable:
    - a. Dimensions.
    - b. Identification of products.
    - c. Fabrication and installation drawings.
    - d. Roughing-in and setting diagrams.
    - e. Wiring diagrams showing field-installed wiring, including power, signal, and control wiring.
    - f. Shopwork manufacturing instructions.
    - g. Templates and patterns.
    - h. Schedules.
    - i. Design calculations.
    - j. Compliance with specified standards.
    - k. Notation of coordination requirements.
    - l. Notation of dimensions established by field measurement.
    - m. Relationship to adjoining construction clearly indicated.
    - n. Wiring Diagrams: Differentiate between manufacturer-installed and field-installed wiring.
  2. Sheet Size: Except for templates, patterns, and similar full-size drawings, submit Shop Drawings on sheets at least 8-1/2 by 11 inches (215 by 280 mm) but no larger than 30 by 40 inches (750 by 1000 mm).
  3. Number of Copies: Submit five opaque copies of each submittal, unless copies are required for operation and maintenance manuals. Submit five copies where copies are required for operation and maintenance manuals. Architect will retain two copies; remainder will be returned.
- D. Samples: Submit Samples for review of kind, color, pattern, and texture for a check of these characteristics with other elements and for a comparison of these characteristics between submittal and actual component as delivered and installed.
1. Transmit Samples that contain multiple, related components such as accessories together in one submittal package.

2. Identification: Attach label on unexposed side of Samples that includes the following:
  - a. Generic description of Sample.
  - b. Product name and name of manufacturer.
  - c. Sample source.
  - d. Number and title of appropriate Specification Section.
  
3. Disposition: Maintain sets of approved Samples at Project site, available for quality-control comparisons throughout the course of construction activity. Sample sets may be used to determine final acceptance of construction associated with each set.
  - a. Samples that may be incorporated into the Work are indicated in individual Specification Sections. Such Samples must be in an undamaged condition at time of use.
  - b. Samples not incorporated into the Work, or otherwise designated as Owner's property, are the property of Contractor.
  
4. Samples for Initial Selection: Submit manufacturer's color charts consisting of units or sections of units showing the full range of colors, textures, and patterns available.
  - a. Number of Samples: Submit three full set(s) of available choices where color, pattern, texture, or similar characteristics are required to be selected from manufacturer's product line. Architect will return submittal with options selected.
  
- E. Product Schedule or List: As required in individual Specification Sections, prepare a written summary indicating types of products required for the Work and their intended location. Include the following information in tabular form:
  1. Type of product. Include unique identifier for each product.
  2. Number and name of room or space.
  3. Location within room or space.
  4. Number of Copies: Submit three copies of product schedule or list, unless otherwise indicated. Architect will return two copies.
    - a. Mark up and retain one returned copy as a Project Record Document.
  
- F. Submittals Schedule: Comply with requirements specified in Division 1 Section "Construction Progress Documentation."
  
- G. Application for Payment: Comply with requirements specified in Division 1 Section "Payment Procedures."
  
- H. Schedule of Values: Comply with requirements specified in Division 1 Section "Payment Procedures."

## 2.2 INFORMATIONAL SUBMITTALS

- A. General: Prepare and submit Informational Submittals required by other Specification Sections.
  1. Number of Copies: Submit two copies of each submittal, unless otherwise indicated. Architect will not return copies.
  2. Certificates and Certifications: Provide a notarized statement that includes signature of entity responsible for preparing certification. Certificates and certifications shall be signed by an officer or other individual authorized to sign documents on behalf of that entity.
  3. Test and Inspection Reports: Comply with requirements specified in Division 1 Section "Quality Requirements."

- B. Coordination Drawings: Comply with requirements specified in Division 1 Section "Project Management and Coordination."
- C. Contractor's Construction Schedule: Comply with requirements specified in Division 1 Section "Construction Progress Documentation."
- D. Welding Certificates: Prepare written certification that welding procedures and personnel comply with requirements in the Contract Documents. Submit record of Welding Procedure Specification (WPS) and Procedure Qualification Record (PQR) on AWS forms. Include names of firms and personnel certified.
- E. Installer Certificates: Prepare written statements on manufacturer's letterhead certifying that Installer complies with requirements in the Contract Documents and, where required, is authorized by manufacturer for this specific Project.
- F. Material Test Reports: Prepare reports written by a qualified testing agency, on testing agency's standard form, indicating and interpreting test results of material for compliance with requirements in the Contract Documents.
- G. Product Test Reports: Prepare written reports indicating current product produced by manufacturer complies with requirements in the Contract Documents. Base reports on evaluation of tests performed by manufacturer and witnessed by a qualified testing agency, or on comprehensive tests performed by a qualified testing agency.
- H. Schedule of Tests and Inspections: Comply with requirements specified in Division 1 Section "Quality Requirements."
- I. Preconstruction Test Reports: Prepare reports written by a qualified testing agency, on testing agency's standard form, indicating and interpreting results of tests performed before installation of product, for compliance with performance requirements in the Contract Documents.
- J. Field Test Reports: Prepare reports written by a qualified testing agency, on testing agency's standard form, indicating and interpreting results of field tests performed either during installation of product or after product is installed in its final location, for compliance with requirements in the Contract Documents.
- K. Insurance Certificates and Bonds: Prepare written information indicating current status of insurance or bonding coverage. Include name of entity covered by insurance or bond, limits of coverage, amounts of deductibles, if any, and term of the coverage.
- L. Construction Photographs and Videotapes: Comply with requirements specified in Division 1 Section "Photographic Documentation."
- M. Material Safety Data Sheets (MSDSs): Submit information directly to Owner; do not submit to Architect, except as required in "Action Submittals" Article.
  - 1. Architect will not review submittals that include MSDSs and will return the entire submittal for resubmittal.



## PART 3 - EXECUTION

### 3.1 CONTRACTOR'S REVIEW

- A. Review each submittal and check for coordination with other Work of the Contract and for compliance with the Contract Documents. Note corrections and field dimensions. Mark with approval stamp before submitting to Architect.
- B. Approval Stamp: Stamp each submittal with a uniform, approval stamp. Include Project name and location, submittal number, Specification Section title and number, name of reviewer, date of Contractor's approval, and statement certifying that submittal has been reviewed, checked, and approved for compliance with the Contract Documents.

### 3.2 ARCHITECT'S/ ACTION

- A. General: Architect will not review submittals that do not bear Contractor's approval stamp and will return them without action.
- B. Action Submittals: Architect will review each submittal, make marks to indicate corrections or modifications required, and return it. Architect will stamp each submittal with an action stamp and will mark stamp appropriately to indicate action taken.
- C. Informational Submittals: Architect will review each submittal and will not return it, or will return it if it does not comply with requirements. Architect will forward each submittal to appropriate party.
- D. Partial submittals are not acceptable, will be considered nonresponsive, and will be returned without review.
- E. Submittals not required by the Contract Documents may not be reviewed and may be discarded.

END OF SECTION 01330

## SECTION 01770 - CLOSEOUT PROCEDURES

### PART 1 - GENERAL

#### 1.1 RELATED DOCUMENTS

- A. Drawings and general provisions of the Contract, including General and Supplementary Conditions and other Division 1 Specification Sections, apply to this Section.

#### 1.2 SUMMARY

- A. This Section includes administrative and procedural requirements for contract closeout, including, but not limited to, the following:
  - 1. Inspection procedures.
  - 2. Warranties.
  - 3. Final cleaning.
- B. Related Sections include the following:
  - 1. Division 1 Section "Payment Procedures" for requirements for Applications for Payment for Substantial and Final Completion.
  - 2. Divisions 2 through 16 Sections for specific closeout and special cleaning requirements for the Work in those Sections.

#### 1.3 SUBSTANTIAL COMPLETION

- A. Preliminary Procedures: Before requesting inspection for determining date of Substantial Completion, complete the following. List items below that are incomplete in request.
  - 1. Prepare a list of items to be completed and corrected (punch list), the value of items on the list, and reasons why the Work is not complete.
  - 2. Advise Owner of pending insurance changeover requirements.
  - 3. Advise Owner of changeover in heat and other utilities.
  - 4. Submit changeover information related to Owner's occupancy, use, operation, and maintenance.
  - 5. Complete final cleaning requirements, including touchup painting.
  - 6. Touch up and otherwise repair and restore marred exposed finishes to eliminate visual defects.
- B. Inspection: Submit a written request for inspection for Substantial Completion. On receipt of request, Architect will either proceed with inspection or notify Contractor of unfulfilled requirements. Architect will prepare the Certificate of Substantial Completion after inspection or will notify Contractor of items, either on Contractor's list or additional items identified by Architect, that must be completed or corrected before certificate will be issued.
  - 1. Reinspection: Request reinspection when the Work identified in previous inspections as incomplete is completed or corrected.
  - 2. Results of completed inspection will form the basis of requirements for Final Completion.

#### 1.4 FINAL COMPLETION

- A. Preliminary Procedures: Before requesting final inspection for determining date of Final Completion, complete the following:
1. Submit a final Application for Payment according to Division 1 Section "Payment Procedures."
  2. Submit certified copy of Architect's Substantial Completion inspection list of items to be completed or corrected (punch list), endorsed and dated by Architect. The certified copy of the list shall state that each item has been completed or otherwise resolved for acceptance.
  3. Submit evidence of final, continuing insurance coverage complying with insurance requirements.
  4. Submit pest-control final inspection report and warranty.
  5. Instruct Owner's personnel in operation, adjustment, and maintenance of products, equipment, and systems. Submit demonstration and training videotapes.
- B. Inspection: Submit a written request for final inspection for acceptance. On receipt of request, Architect will either proceed with inspection or notify Contractor of unfulfilled requirements. Architect will prepare a final Certificate for Payment after inspection or will notify Contractor of construction that must be completed or corrected before certificate will be issued.
1. Reinspection: Request reinspection when the Work identified in previous inspections as incomplete is completed or corrected.

#### 1.5 LIST OF INCOMPLETE ITEMS (PUNCH LIST)

- A. Preparation: Submit three copies of list. Include name and identification of each space and area affected by construction operations for incomplete items and items needing correction including, if necessary, areas disturbed by Contractor that are outside the limits of construction.
1. Organize list of spaces in sequential order, starting with exterior areas first and proceeding from lowest floor to highest floor.
  2. Organize items applying to each space by major element, including categories for ceiling, individual walls, floors, equipment, and building systems.
  3. Include the following information at the top of each page:
    - a. Project name.
    - b. Date.
    - c. Name of Architect.
    - d. Name of Contractor.
    - e. Page number.

#### 1.6 WARRANTIES

- A. Submittal Time: Submit written warranties on request of Architect for designated portions of the Work where commencement of warranties other than date of Substantial Completion is indicated.
- B. Partial Occupancy: Submit properly executed warranties within 15 days of completion of designated portions of the Work that are completed and occupied or used by Owner during construction period by separate agreement with Contractor.

- C. Organize warranty documents into an orderly sequence based on the table of contents of the Project Manual.
  - 1. Bind warranties and bonds in heavy-duty, 3-ring, vinyl-covered, loose-leaf binders, thickness as necessary to accommodate contents, and sized to receive **8-1/2-by-11-inch (215-by-280-mm)** paper.
  - 2. Provide heavy paper dividers with plastic-covered tabs for each separate warranty. Mark tab to identify the product or installation. Provide a typed description of the product or installation, including the name of the product and the name, address, and telephone number of Installer.
  - 3. Identify each binder on the front and spine with the typed or printed title "WARRANTIES," Project name, and name of Contractor.
- D. Provide additional copies of each warranty to include in operation and maintenance manuals.

## PART 2 - PRODUCTS

### 2.1 MATERIALS

- A. Cleaning Agents: Use cleaning materials and agents recommended by manufacturer or fabricator of the surface to be cleaned. Do not use cleaning agents that are potentially hazardous to health or property or that might damage finished surfaces.

## PART 3 - EXECUTION

### 3.1 FINAL CLEANING

- A. General: Provide final cleaning. Conduct cleaning and waste-removal operations to comply with local laws and ordinances and Federal and local environmental and antipollution regulations.
- B. Cleaning: Employ experienced workers or professional cleaners for final cleaning. Clean each surface or unit to condition expected in an average commercial building cleaning and maintenance program. Comply with manufacturer's written instructions.
  - 1. Complete the following cleaning operations before requesting inspection for certification of Substantial Completion for entire Project or for a portion of Project:
    - a. Clean Project site, yard, and grounds, in areas disturbed by construction activities, including landscape development areas, of rubbish, waste material, litter, and other foreign substances.
    - b. Sweep paved areas broom clean. Remove petrochemical spills, stains, and other foreign deposits.
    - c. Rake grounds that are neither planted nor paved to a smooth, even-textured surface.
    - d. Remove tools, construction equipment, machinery, and surplus material from Project site.
    - e. Clean exposed exterior and interior hard-surfaced finishes to a dirt-free condition, free of stains, films, and similar foreign substances. Avoid disturbing natural weathering of exterior surfaces. Restore reflective surfaces to their original condition.
    - f. Remove debris and surface dust from limited access spaces, including roofs, plenums, shafts, trenches, equipment vaults, manholes, attics, and similar spaces.
    - g. Sweep concrete floors broom clean in unoccupied spaces.
    - h. Vacuum carpet and similar soft surfaces, removing debris and excess nap; shampoo if visible soil or stains remain.

- i. Clean transparent materials, including mirrors and glass in doors and windows. Remove glazing compounds and other noticeable, vision-obscuring materials. Replace chipped or broken glass and other damaged transparent materials. Polish mirrors and glass, taking care not to scratch surfaces.
  - j. Remove labels that are not permanent.
  - k. Touch up and otherwise repair and restore marred, exposed finishes and surfaces. Replace finishes and surfaces that cannot be satisfactorily repaired or restored or that already show evidence of repair or restoration.
    - 1) Do not paint over "UL" and similar labels, including mechanical and electrical nameplates.
  - l. Wipe surfaces of mechanical and electrical equipment, elevator equipment, and similar equipment. Remove excess lubrication, paint and mortar droppings, and other foreign substances.
  - m. Replace parts subject to unusual operating conditions.
  - n. Clean plumbing fixtures to a sanitary condition, free of stains, including stains resulting from water exposure.
  - o. Replace disposable air filters and clean permanent air filters. Clean exposed surfaces of diffusers, registers, and grills.
  - p. Clean ducts, blowers, and coils if units were operated without filters during construction.
  - q. Clean light fixtures, lamps, globes, and reflectors to function with full efficiency. Replace burned-out bulbs, and those noticeably dimmed by hours of use, and defective and noisy starters in fluorescent and mercury vapor fixtures to comply with requirements for new fixtures.
  - r. Leave Project clean and ready for occupancy.
- C. Pest Control: Engage an experienced, licensed exterminator to make a final inspection and rid Project of rodents, insects, and other pests. Prepare a report.
- D. Comply with safety standards for cleaning. Do not burn waste materials. Do not bury debris or excess materials on Owner's property. Do not discharge volatile, harmful, or dangerous materials into drainage systems. Remove waste materials from Project site and dispose of lawfully.

END OF SECTION 01770

## SECTION 01781 - PROJECT RECORD DOCUMENTS

### PART 1 - GENERAL

#### 1.1 RELATED DOCUMENTS

- A. Drawings and general provisions of the Contract, including General and Supplementary Conditions and other Division 1 Specification Sections, apply to this Section.

#### 1.2 SUMMARY

- A. This Section includes administrative and procedural requirements for Project Record Documents, including the following:
  - 1. Record Drawings.
  - 2. Record Product Data.
- B. Related Sections include the following:
  - 1. Division 1 Section "Closeout Procedures" for general closeout procedures.
  - 2. Divisions 2 through 16 Sections for specific requirements for Project Record Documents of the Work in those Sections.

#### 1.3 SUBMITTALS

- A. Record Drawings: Comply with the following:
  - 1. Number of Copies: Submit two set(s) of marked-up Record Prints.
  - 2. Number of Copies: Submit copies of Record Drawings as follows:
    - a. Initial Submittal: Submit one set(s) of corrected Record Transparencies and one set(s) of marked-up Record Prints. Architect will initial and date each transparency and mark whether general scope of changes, additional information recorded, and quality of drafting are acceptable. Architect will return transparencies and prints for organizing into sets, printing, binding, and final submittal.
    - b. Final Submittal: Submit two set(s) of marked-up Record Prints, one set(s) of Record Transparencies, and three copies printed from Record Transparencies. Print each Drawing, whether or not changes and additional information were recorded.
    - c. Final Submittal: Submit two set(s) of marked-up Record Prints, one set(s) of Record CAD Drawing files, one set(s) of Record CAD Drawing plots, and three copies printed from record plots. Plot and print each Drawing, whether or not changes and additional information were recorded.
- B. Record Product Data: Submit two copy of each Product Data submittal.
  - 1. Where Record Product Data is required as part of operation and maintenance manuals, submit marked-up Product Data as an insert in manual instead of submittal as Record Product Data.

## PART 2 - PRODUCTS

### 2.1 RECORD DRAWINGS

- A. Record Prints: Maintain one set of blue- or black-line white prints of the Contract Drawings and Shop Drawings.
1. Preparation: Mark Record Prints to show the actual installation where installation varies from that shown originally. Require individual or entity who obtained record data, whether individual or entity is Installer, subcontractor, or similar entity, to prepare the marked-up Record Prints.
    - a. Give particular attention to information on concealed elements that would be difficult to identify or measure and record later.
    - b. Accurately record information in an understandable drawing technique.
    - c. Record data as soon as possible after obtaining it. Record and check the markup before enclosing concealed installations.
  2. Content: Types of items requiring marking include, but are not limited to, the following:
    - a. Dimensional changes to Drawings.
    - b. Revisions to details shown on Drawings.
    - c. Depths of foundations below first floor.
    - d. Locations and depths of underground utilities.
    - e. Revisions to routing of piping and conduits.
    - f. Revisions to electrical circuitry.
    - g. Actual equipment locations.
    - h. Duct size and routing.
    - i. Locations of concealed internal utilities.
    - j. Changes made by Change Order or Construction Change Directive.
    - k. Changes made following Architect's written orders.
    - l. Details not on the original Contract Drawings.
    - m. Field records for variable and concealed conditions.
    - n. Record information on the Work that is shown only schematically.
  3. Mark the Contract Drawings or Shop Drawings, whichever is most capable of showing actual physical conditions, completely and accurately. If Shop Drawings are marked, show cross-reference on the Contract Drawings.
  4. Mark record sets with erasable, red-colored pencil. Use other colors to distinguish between changes for different categories of the Work at same location.
  5. Mark important additional information that was either shown schematically or omitted from original Drawings.
  6. Note Construction Change Directive numbers, alternate numbers, Change Order numbers, and similar identification, where applicable.
- B. Record Transparencies: Immediately before inspection for Certificate of Substantial Completion, review marked-up Record Prints with Architect. When authorized, prepare a full set of corrected transparencies of the Contract Drawings and Shop Drawings.
1. Incorporate changes and additional information previously marked on Record Prints. Erase, redraw, and add details and notations where applicable.
  2. Refer instances of uncertainty to Architect for resolution.
  3. Print the Contract Drawings and Shop Drawings for use as Record Transparencies. Architect will make the Contract Drawings available to Contractor's print shop.

- C. Newly Prepared Record Drawings: Prepare new Drawings instead of preparing Record Drawings where Architect determines that neither the original Contract Drawings nor Shop Drawings are suitable to show actual installation.
  - 1. New Drawings may be required when a Change Order is issued as a result of accepting an alternate, substitution, or other modification.
  - 2. Consult Architect for proper scale and scope of detailing and notations required to record the actual physical installation and its relation to other construction. Integrate newly prepared Record Drawings into Record Drawing sets; comply with procedures for formatting, organizing, copying, binding, and submitting.
- D. Format: Identify and date each Record Drawing; include the designation "PROJECT RECORD DRAWING" in a prominent location.
  - 1. Record Prints: Organize Record Prints and newly prepared Record Drawings into manageable sets. Bind each set with durable paper cover sheets. Include identification on cover sheets.
  - 2. Record Transparencies: Organize into unbound sets matching Record Prints. Place transparencies in durable tube-type drawing containers with end caps. Mark end cap of each container with identification. If container does not include a complete set, identify Drawings included.
  - 3. Identification: As follows:
    - a. Project name.
    - b. Date.
    - c. Designation "PROJECT RECORD DRAWINGS."
    - d. Name of Architect.
    - e. Name of Contractor.

## 2.2 RECORD PRODUCT DATA

- A. Preparation: Mark Product Data to indicate the actual product installation where installation varies substantially from that indicated in Product Data submittal.
  - 1. Give particular attention to information on concealed products and installations that cannot be readily identified and recorded later.
  - 2. Include significant changes in the product delivered to Project site and changes in manufacturer's written instructions for installation.
  - 3. Note related Change Orders and Record Drawings where applicable.

## 2.3 MISCELLANEOUS RECORD SUBMITTALS

- A. Assemble miscellaneous records required by other Specification Sections for miscellaneous record keeping and submittal in connection with actual performance of the Work. Bind or file miscellaneous records and identify each, ready for continued use and reference.



PART 3 - EXECUTION

3.1 RECORDING AND MAINTENANCE

- A. Recording: Maintain one copy of each submittal during the construction period for Project Record Document purposes. Post changes and modifications to Project Record Documents as they occur; do not wait until the end of Project.
- B. Maintenance of Record Documents and Samples: Store Record Documents and Samples in the field office apart from the Contract Documents used for construction. Do not use Project Record Documents for construction purposes. Maintain Record Documents in good order and in a clean, dry, legible condition, protected from deterioration and loss. Provide access to Project Record Documents for Architect's reference during normal working hours.

END OF SECTION 01781

## SECTION 02361 - TERMITE CONTROL

### PART 1 - GENERAL

#### 1.1 RELATED DOCUMENTS

- A. Drawings and general provisions of the Contract, including General and Supplementary Conditions and Division 1 Specification Sections, apply to this Section.

#### 1.2 SUMMARY

- A. This Section includes the following:
  - 1. Soil treatment with termiticide.

#### 1.3 PERFORMANCE REQUIREMENTS

- A. Service Life of Soil Treatment: Soil treatment by use of a termiticide that is effective for not less than five years against infestation of subterranean termites.

#### 1.4 SUBMITTALS

- A. Product Data: For termiticide.
  - 1. Include the EPA-Registered Label for termiticide products.
- B. Product Certificates: For termite control products, signed by product manufacturer.
- C. Qualification Data: For Installer of termite control products.
- D. Soil Treatment Application Report: After application of termiticide is completed, submit report for Owner's record information, including the following:
  - 1. Date and time of application.
  - 2. Moisture content of soil before application.
  - 3. Brand name and manufacturer of termiticide.
  - 4. Quantity of undiluted termiticide used.
  - 5. Dilutions, methods, volumes, and rates of application used.
  - 6. Areas of application.
  - 7. Water source for application.
- E. Warranty: Special warranty specified in this Section.

## 1.5 QUALITY ASSURANCE

- A. Installer Qualifications: A specialist who is licensed according to regulations of authorities having jurisdiction to apply termite control treatment and products in jurisdiction where Project is located.
- B. Regulatory Requirements: Formulate and apply termiticides according to the EPA-Registered Label.
- C. Source Limitations: Obtain termite control products from a single manufacturer for each product.

## 1.6 PROJECT CONDITIONS

- A. Environmental Limitations: To ensure penetration, do not treat soil that is water saturated or frozen. Do not treat soil while precipitation is occurring. Comply with requirements of the EPA-Registered Label and requirements of authorities having jurisdiction.

## 1.7 COORDINATION

- A. Coordinate soil treatment application with excavating, filling, grading, and concreting operations. Treat soil under footings, grade beams, and ground-supported slabs before construction.

## 1.8 WARRANTY

- A. Special Warranty: Manufacturer's standard form, signed by Applicator and Contractor certifying that termite control work, consisting of applied soil termiticide treatment, will prevent infestation of subterranean termites. If subterranean termite activity or damage is discovered during warranty period, re-treat soil and repair or replace damage caused by termite infestation.

- 1. Warranty Period: Five years from date of Substantial Completion.

## PART 2 - PRODUCTS

### 2.1 MANUFACTURERS

- A. Available Manufacturers: Subject to compliance with requirements, manufacturers offering products that may be incorporated into the Work include, but are not limited to, the following:

- 1. Termiticides:
  - a. Bayer Corporation; Premise 75.
  - b. Dow AgroSciences LLC; Dursban TC.
  - c. FMC Corporation, Agricultural Products Group; Torpedo.
  - d. Syngenta; Demon TC.

### 2.2 SOIL TREATMENT

- A. Termiticide: Provide an EPA-registered termiticide complying with requirements of authorities having jurisdiction, in an aqueous solution formulated to prevent termite infestation. Provide quantity required for application at the label volume and rate for the maximum termiticide concentration allowed for each specific use, according to product's EPA-Registered Label.

## PART 3 - EXECUTION

### 3.1 EXAMINATION

- A. Examine substrates, areas, and conditions, with Applicator present, for compliance with requirements for moisture content of soil, interfaces with earthwork, slab and foundation work, landscaping, and other conditions affecting performance of termite control.
  - 1. Proceed with application only after unsatisfactory conditions have been corrected.

### 3.2 PREPARATION

- A. General: Comply with the most stringent requirements of authorities having jurisdiction and with manufacturer's written instructions for preparation before beginning application of termite control treatment. Remove all extraneous sources of wood cellulose and other edible materials such as wood debris, tree stumps and roots, stakes, formwork, and construction waste wood from soil within and around foundations.
- B. Soil Treatment Preparation: Remove foreign matter and impermeable soil materials that could decrease treatment effectiveness on areas to be treated. Loosen, rake, and level soil to be treated except previously compacted areas under slabs and footings. Termiticides may be applied before placing compacted fill under slabs if recommended in writing by termiticide manufacturer.
  - 1. Fit filling hose connected to water source at the site with a backflow preventer, complying with requirements of authorities having jurisdiction.

### 3.3 APPLICATION, GENERAL

- A. General: Comply with the most stringent requirements of authorities having jurisdiction and with manufacturer's EPA-Registered Label for products.

### 3.4 APPLYING SOIL TREATMENT

- A. Application: Mix soil treatment termiticide solution to a uniform consistency. Provide quantity required for application at the label volume and rate for the maximum specified concentration of termiticide, according to manufacturer's EPA-Registered Label, to the following so that a continuous horizontal and vertical termiticidal barrier or treated zone is established around and under building construction. Distribute treatment evenly.
  - 1. Slabs-on-Grade: Under ground-supported slab construction, including footings, building slabs, and attached slabs as an overall treatment. Treat soil materials before concrete footings and slabs are placed.
  - 2. Foundations: Adjacent soil including soil along the entire inside perimeter of foundation walls, along both sides of interior partition walls, around plumbing pipes and electric conduit penetrating the slab, and around interior column footers, piers; also along the entire outside perimeter, from grade to bottom of footing. Avoid soil washout around footings.
  - 3. Tilt-Up Concrete: : At expansion joints, cold joints, control joints, and areas below grade.
  - 4. Penetrations: At expansion joints, control joints, and areas where slabs will be penetrated.

- B. Avoid disturbance of treated soil after application. Keep off treated areas until completely dry.
- C. Protect termiticide solution, dispersed in treated soils and fills, from being diluted until ground-supported slabs are installed. Use waterproof barrier according to EPA-Registered Label instructions.
- D. Post warning signs in areas of application.
- E. Reapply soil treatment solution to areas disturbed by subsequent excavation, grading, landscaping, or other construction activities following application.

END OF SECTION 02361

## SECTION 07210 - BUILDING INSULATION

### PART 1 - GENERAL

#### 1.1 RELATED DOCUMENTS

- A. Drawings and general provisions of the Contract, including General and Supplementary Conditions and Division 1 Specification Sections, apply to this Section.

#### 1.2 SUMMARY

- A. This Section includes the following:
  - 1. Cavity-wall insulation.
  - 2. Concealed building insulation.
- B. Related Sections include the following:
  - 1. Division 9 Section "Portland Cement Plaster" for installation in metal-framed assemblies of insulation specified by referencing this Section.
  - 2. Division 15 Section "Mechanical Insulation."

#### 1.3 DEFINITIONS

- A. Mineral-Fiber Insulation: Insulation composed of rock-wool fibers, slag-wool fibers, or glass fibers; produced in boards and blanket with latter formed into batts (flat-cut lengths) or rolls.

#### 1.4 PERFORMANCE REQUIREMENTS

#### 1.5 SUBMITTALS

- A. Product Data: For each type of product indicated.
- B. Samples for Verification: Full-size units for each type of exposed insulation indicated.
- C. Product Test Reports: Based on evaluation of comprehensive tests performed by a qualified testing agency for insulation products.
- D. Research/Evaluation Reports: For foam-plastic insulation.

#### 1.6 QUALITY ASSURANCE

- A. Source Limitations: Obtain each type of building insulation through one source from a single manufacturer.
- B. Fire-Test-Response Characteristics: Provide insulation and related materials with the fire-test-response characteristics indicated, as determined by testing identical products per test method indicated below by

UL or another testing and inspecting agency acceptable to authorities having jurisdiction. Identify materials with appropriate markings of applicable testing and inspecting agency.

1. Surface-Burning Characteristics: ASTM E 84.
2. Fire-Resistance Ratings: ASTM E 119.
3. Combustion Characteristics: ASTM E 136.

#### 1.7 DELIVERY, STORAGE, AND HANDLING

- A. Protect insulation materials from physical damage and from deterioration by moisture, soiling, and other sources. Store inside and in a dry location. Comply with manufacturer's written instructions for handling, storing, and protecting during installation.

### PART 2 - PRODUCTS

#### 2.1 MANUFACTURERS

- A. In other Part 2 articles where titles below introduce lists, the following requirements apply to product selection:
  1. Available Manufacturers: Subject to compliance with requirements, manufacturers offering products that may be incorporated into the Work include, but are not limited to, manufacturers specified.

#### 2.2 GLASS-FIBER BLANKET INSULATION

- A. Available Manufacturers:
  1. CertainTeed Corporation.
  2. Johns Manville.
  3. Knauf Fiber Glass.
  4. Owens Corning.
- B. Unfaced, Glass-Fiber Blanket Insulation: ASTM C 665, Type I (blankets without membrane facing); consisting of fibers; with maximum flame-spread and smoke-developed indexes of 25 and 50, respectively; passing ASTM E 136 for combustion characteristics.
- C. Faced, Glass-Fiber Blanket Insulation: ASTM C 665, Type III (blankets with reflective membrane facing), Class A (membrane-faced surface with a flame-spread index of 25 or less); Category 1 (membrane is a vapor barrier), faced with foil-scrim-kraft, foil-scrim, or foil-scrim-polyethylene vapor-retarder membrane on 1 face.
- D. Where glass-fiber blanket insulation is indicated by the following thicknesses, provide blankets in batt or roll form with thermal resistances indicated:
  1. **3-5/8 inches (92 mm)** thick with a thermal resistance of **11 deg F x h x sq. ft./Btu at 75 deg F (1.9 K x sq. m/W at 24 deg C)**.
  2. **6-1/2 inches (165 mm)** thick with a thermal resistance of **19 deg F x h x sq. ft./Btu at 75 deg F (3.3 K x sq. m/W at 24 deg C)**.

## 2.3 MASONRY CELL INSULATION

- A. Manufacturer: Tailored Chemical Products, Inc., or equal
- B. Foamed in place insulation, non-toxic, amino-palst resin, R value for 8” concrete block equals 14.2 complying with HUD use of materials bulletin #74, DOE proposed standards ( using ASTM Procedures ) and Florida Building Standards. Core Fill 500 Insulation

## 2.4 AUXILIARY INSULATING MATERIALS

- A. Vapor-Retarder Tape: Pressure-sensitive tape of type recommended by insulation manufacturers for sealing joints and penetrations in vapor-retarder facings.
- B. Adhesive for Bonding Insulation: Product with demonstrated capability to bond insulation securely to substrates indicated without damaging insulation and substrates.

## PART 3 - EXECUTION

### 3.1 EXAMINATION

- A. Examine substrates and conditions, with Installer present, for compliance with requirements of Sections in which substrates and related work are specified and for other conditions affecting performance.
  - 1. Proceed with installation only after unsatisfactory conditions have been corrected.

### 3.2 PREPARATION

- A. Clean substrates of substances harmful to insulation or vapor retarders, including removing projections capable of puncturing vapor retarders or of interfering with insulation attachment.

### 3.3 INSTALLATION, GENERAL

- A. Comply with insulation manufacturer's written instructions applicable to products and application indicated.
- B. Install insulation that is undamaged, dry, and unsoiled and that has not been left exposed at any time to ice, rain, and snow.
- C. Extend insulation in thickness indicated to envelop entire area to be insulated. Cut and fit tightly around obstructions and fill voids with insulation. Remove projections that interfere with placement.
- D. Water-Piping Coordination: If water piping is located within insulated exterior walls, coordinate location of piping to ensure that it is placed on warm side of insulation and insulation encapsulates piping.
- E. For preformed insulating units, provide sizes to fit applications indicated and selected from manufacturer's standard thicknesses, widths, and lengths. Apply single layer of insulation units to produce thickness indicated unless multiple layers are otherwise shown or required to make up total thickness.



### 3.4 INSTALLATION OF GENERAL BUILDING INSULATION

- A. Install mineral-fiber insulation in cavities formed by framing members according to the following requirements:
1. Use insulation widths and lengths that fill the cavities formed by framing members. If more than one length is required to fill cavity, provide lengths that will produce a snug fit between ends.
  2. Place insulation in cavities formed by framing members to produce a friction fit between edges of insulation and adjoining framing members.
  3. Maintain **3-inch (76-mm)** clearance of insulation around recessed lighting fixtures.
  4. Install eave ventilation troughs between roof framing members in insulated attic spaces at vented eaves.
  5. For metal-framed wall cavities where cavity heights exceed **96 inches (2438 mm)**, support unfaced blankets mechanically and support faced blankets by taping stapling flanges to flanges of metal studs.

### 3.5 PROTECTION

- A. Protect installed insulation from damage due to harmful weather exposures, physical abuse, and other causes. Provide temporary coverings or enclosures where insulation is subject to abuse and cannot be concealed and protected by permanent construction immediately after installation.

END OF SECTION 07210

## SECTION 07411 - METAL ROOF PANELS

### PART 1 - GENERAL

#### 1.1 RELATED DOCUMENTS

- A. Drawings and general provisions of the Contract, including General and Supplementary Conditions and Division 1 Specification Sections, apply to this Section.

#### 1.2 SUMMARY

- A. This Section includes the following:
  - 1. Factory-formed and field-assembled, standing-seam metal roof panels.
- B. Related Sections include the following:
  - 1. Division 7 Section "Joint Sealants" for field-applied sealants not otherwise specified in this Section.

#### 1.3 DEFINITIONS

- A. Metal Roof Panel Assembly: Metal roof panels, attachment system components, miscellaneous metal framing, thermal insulation, and accessories necessary for a complete weathertight roofing system.
- B. Solar Flux: Direct and diffuse radiation from the sun received at ground level over the solar spectrum, expressed in watts per square meter.
- C. Solar Reflectance: Fraction of solar flux reflected by a surface, expressed as a percent or within the range of 0.00 and 1.00.
- D. Steel Sheet Thickness: Minimum thickness of base metal without metallic coatings or painted finishes.

#### 1.4 PERFORMANCE REQUIREMENTS

- A. General: Provide metal roof panel assemblies that comply with performance requirements specified as determined by testing manufacturers' standard assemblies similar to those indicated for this Project, by a qualified testing and inspecting agency.
- B. Wind-Uplift Resistance: Provide metal roof panel assemblies that comply with UL 580 for wind-uplift resistance class indicated.
  - 1. Uniform pressure as indicated on the Structural drawings.
- C. FMG Listing: Provide metal roof panels and component materials that comply with requirements in FMG 4471 as part of a panel roofing system and that are listed in FMG's "Approval Guide" for Class 1 or noncombustible construction, as applicable. Identify materials with FMG markings.
  - 1. Fire/Windstorm Classification: Class 1A- 120.

2. Hail Resistance: MH.

D. Thermal Movements: Provide metal roof panel assemblies that allow for thermal movements resulting from the following maximum change (range) in ambient and surface temperatures by preventing buckling, opening of joints, overstressing of components, failure of joint sealants, failure of connections, and other detrimental effects. Base engineering calculation on surface temperatures of materials due to both solar heat gain and nighttime-sky heat loss.

1. Temperature Change (Range): 120 deg F (67 deg C), ambient; 180 deg F (100 deg C), material surfaces.

## 1.5 SUBMITTALS

A. Product Data: Include construction details, material descriptions, dimensions of individual components and profiles, and finishes for each type of metal roof panel and accessory.

B. Shop Drawings: Show fabrication and installation layouts of metal roof panels; details of edge conditions, joints, panel profiles, corners, anchorages, trim, flashings, closures, and accessories; and special details. Distinguish between factory- and field-assembled work.

1. Accessories: Include details of the following items, at a scale of not less than 1-1/2 inches per 12 inches (1:10):

- a. Flashing and trim.
- b. Gutters.
- c. Downspouts.

2. For installed products indicated to comply with design loads, include structural analysis data signed and sealed by the qualified professional engineer responsible for their preparation.

C. Coordination Drawings: Roof plans drawn to scale and coordinating penetrations and roof-mounted items. Show the following:

1. Roof panels and attachments.
2. Purlins and rafters.
3. Roof-mounted items including roof hatches, equipment supports, pipe supports and penetrations, lighting fixtures, snow guards, and items mounted on roof curbs.

D. Samples for Initial Selection: For each type of metal roof panel indicated with factory-applied color finishes.

1. Include similar Samples of trim and accessories involving color selection.

E. Samples for Verification: For each type of exposed finish required, prepared on Samples of size indicated below.

1. Metal Roof Panels: 12 inches (300 mm) long by actual panel width. Include fasteners, clips, closures, and other metal roof panel accessories.
2. Trim and Closures: 12 inches (300 mm) long. Include fasteners and other exposed accessories.
3. Accessories: 12-inch- (300-mm-) long Samples for each type of accessory.

- F. Qualification Data: For Installer.
- G. Material Certificates: For, signed by manufacturers.
- H. Product Test Reports: Based on evaluation of comprehensive tests performed by a qualified testing agency, for the following:
  - 1. Metal Roof Panels: Include reports for air infiltration, water penetration, and structural performance.
  - 2. Insulation and Vapor Retarders: Include reports for thermal resistance, fire-test-response characteristics, water-vapor transmission, and water absorption.
- I. Maintenance Data: For metal roof panels to include in maintenance manuals.
- J. Warranties: Special warranties specified in this Section.

## 1.6 QUALITY ASSURANCE

- A. Installer Qualifications: An employer of workers trained and approved by manufacturer.
  - 1. Installer's responsibilities include fabricating and installing metal roof panel assemblies and providing professional engineering services needed to assume engineering responsibility.
  - 2. Engineering Responsibility: Preparation of data for metal roof panels, including Shop Drawings, based on testing and engineering analysis of manufacturer's standard units in assemblies similar to those indicated for this Project.
- B. Source Limitations: Obtain each type of metal roof panels through one source from a single manufacturer.
- C. Product Options: Drawings indicate size, profiles, and dimensional requirements of metal roof panels and are based on the specific system indicated. Refer to Division 1 Section "Product Requirements."
  - 1. Do not modify intended aesthetic effects, as judged solely by Architect, except with Architect's approval. If modifications are proposed, submit comprehensive explanatory data to Architect for review.
- D. Fire-Resistance Ratings: Where indicated, provide metal roof panels identical to those of assemblies tested for fire resistance per ASTM E 119 by a testing and inspecting agency acceptable to authorities having jurisdiction.
  - 1. Combustion Characteristics: ASTM E 136.
  - 2. Fire-Resistance Ratings: Indicated by design designations from UL's "Fire Resistance Directory" or from the listings of another testing and inspecting agency.
  - 3. Metal roof panels shall be identified with appropriate markings of applicable testing and inspecting agency.
- E. Surface-Burning Characteristics: Provide insulated metal roof panels having insulation core material with the following surface-burning characteristics as determined by testing identical products per ASTM E 84 by UL or another testing and inspecting agency acceptable to authorities having jurisdiction:
  - 1. Flame-Spread Index: 25 or less, unless otherwise indicated.
  - 2. Smoke-Developed Index: 450 or less, unless otherwise indicated.

## 1.7 DELIVERY, STORAGE, AND HANDLING

- A. Deliver components, sheets, metal roof panels, and other manufactured items so as not to be damaged or deformed. Package metal roof panels for protection during transportation and handling.
- B. Unload, store, and erect metal roof panels in a manner to prevent bending, warping, twisting, and surface damage.
- C. Stack metal roof panels on platforms or pallets, covered with suitable weathertight and ventilated covering. Store metal roof panels to ensure dryness. Do not store metal roof panels in contact with other materials that might cause staining, denting, or other surface damage.
- D. Protect strippable protective covering on metal roof panels from exposure to sunlight and high humidity, except to extent necessary for period of metal roof panel installation.
- E. Protect foam-plastic insulation as follows:
  - 1. Do not expose to sunlight, except to extent necessary for period of installation and concealment.
  - 2. Protect against ignition at all times. Do not deliver foam-plastic insulation materials to Project site before installation time.
  - 3. Complete installation and concealment of plastic materials as rapidly as possible in each area of construction.

## 1.8 PROJECT CONDITIONS

- A. Weather Limitations: Proceed with installation only when existing and forecasted weather conditions permit assembly of metal roof panels to be performed according to manufacturers' written instructions and warranty requirements.
- B. Field Measurements: Verify locations of roof framing and roof opening dimensions by field measurements before metal roof panel fabrication and indicate measurements on Shop Drawings.

## 1.9 COORDINATION

- A. Coordinate installation of roof curbs, equipment supports, and roof penetrations, which are specified in Division 7 Section "Roof Accessories."
- B. Coordinate metal panel roof assemblies with rain drainage work, flashing, trim, and construction of parapets, walls, and other adjoining work to provide a leakproof, secure, and noncorrosive installation.

## 1.10 WARRANTY

- A. Special Warranty: Manufacturer's standard form in which manufacturer agrees to repair or replace components of metal roof panel assemblies that fail in materials or workmanship within specified warranty period.
  - 1. Failures include, but are not limited to, the following:
    - a. Structural failures, including rupturing, cracking, or puncturing.
    - b. Deterioration of metals, metal finishes, and other materials beyond normal weathering.

2. Warranty Period: Two years from date of Substantial Completion.
- B. Special Warranty on Panel Finishes: Manufacturer's standard form in which manufacturer agrees to repair finish or replace metal roof panels that show evidence of deterioration of factory-applied finishes within specified warranty period.
1. Fluoropolymer Finish: Deterioration includes, but is not limited to, the following:
    - a. Color fading more than 5 Hunter units when tested according to ASTM D 2244.
    - b. Chalking in excess of a No. 8 rating when tested according to ASTM D 4214.
    - c. Cracking, checking, peeling, or failure of paint to adhere to bare metal.
  2. Finish Warranty Period: 20 years from date of Substantial Completion.
- C. Special Weathertightness Warranty for Standing-Seam Metal Roof Panels: Manufacturer's standard form in which manufacturer agrees to repair or replace standing-seam metal roof panel assemblies that fail to remain weathertight, including leaks, within specified warranty period.
1. Warranty Period: 20 years from date of Substantial Completion.

## PART 2 - PRODUCTS

### 2.1 MANUFACTURERS

- A. In other Part 2 articles where titles below introduce lists, the following requirements apply for product selection:
1. Available Manufacturers: Subject to compliance with requirements, manufacturers offering products that may be incorporated into the Work include, but are not limited to, the manufacturers specified.

### 2.2 PANEL MATERIALS

- A. Aluminum Sheet: Coil-coated sheet, **ASTM B 209** (**ASTM B 209M**), alloy as standard with manufacturer, with temper as required to suit forming operations and structural performance required.
1. Surface: Embossed finish.
  2. Exposed Coil-Coated Finish:
    - a. 3-Coat Fluoropolymer: AAMA 620. Fluoropolymer finish containing not less than 70 percent PVDF resin by weight in both color coat and clear topcoat. Prepare, pretreat, and apply coating to exposed metal surfaces to comply with coating and resin manufacturers' written instructions.
  3. Concealed Finish: Apply pretreatment and manufacturer's standard white or light-colored acrylic or polyester backer finish, consisting of prime coat and wash coat with a minimum total dry film thickness of **0.5 mil (0.013 mm)**.

B. Panel Sealants:

1. Sealant Tape: Pressure-sensitive, 100 percent solids, gray polyisobutylene compound sealant tape with release-paper backing. Provide permanently elastic, nonsag, nontoxic, nonstaining tape **1/2 inch (13 mm)** wide and **1/8 inch (3 mm)** thick.
2. Joint Sealant: ASTM C 920; elastomeric polyurethane, polysulfide, or silicone sealant; of type, grade, class, and use classifications required to seal joints in metal roof panels and remain weathertight; and as recommended in writing by metal roof panel manufacturer.
3. Butyl-Rubber-Based, Solvent-Release Sealant: ASTM C 1311.

2.3 UNDERLAYMENT MATERIALS

A. Self-Adhering High Temperature, Polyethylene-Faced Sheet: ASTM D 1970, **40 mils (1.0 mm)** thick minimum, consisting of slip-resisting polyethylene-film reinforcing and top surface laminated to SBS-modified asphalt adhesive, with release-paper backing; cold applied.

1. Available Products:

- a. Carlisle Coatings & Waterproofing, Div. of Carlisle Companies Inc.; Dri-Start "A."
- b. Grace, W. R. & Co.; Grace Ice and Water Shield.
- c. Henry Company; Perma-Seal PE.
- d. Johns Manville International, Inc.; Roof Defender.
- e. NEI Advanced Composite Technology; AC Poly Ice and StormSeal.
- f. Owens Corning; WeatherLock.
- g. Polyguard Products, Inc.; Polyguard Deck Guard.
- h. Protecto Wrap Company; Rainproof TM.

B. Slip Sheet: Building paper, minimum **5 lb/100 sq. ft. (0.24 kg/sq. m)**, rosin sized.

2.4 MISCELLANEOUS MATERIALS

A. Fasteners: Self-tapping screws, bolts, nuts, self-locking rivets and bolts, end-welded studs, and other suitable fasteners designed to withstand design loads. Provide exposed fasteners with heads matching color of metal roof panels by means of plastic caps or factory-applied coating.

1. Fasteners for Roof Panels: Self-drilling or self-tapping 410 stainless or zinc-alloy steel hex washer head, with EPDM or PVC washer under heads of fasteners bearing on weather side of metal roof panels.
2. Fasteners for Flashing and Trim: Blind fasteners or self-drilling screws with hex washer head.
3. Blind Fasteners: High-strength aluminum or stainless-steel rivets.

B. Bituminous Coating: Cold-applied asphalt mastic, SSPC-Paint 12, compounded for **15-mil (0.4-mm)** dry film thickness per coat. Provide inert-type noncorrosive compound free of asbestos fibers, sulfur components, and other deleterious impurities.

2.5 STANDING-SEAM METAL ROOF PANELS

A. General: Provide factory-formed metal roof panels designed to be field assembled by lapping and interconnecting raised side edges of adjacent panels with joint type indicated and mechanically attaching panels to supports using concealed clips in side laps. Include clips, cleats, pressure plates, and accessories required for weathertight installation.

1. Aluminum Panel Systems: Unless more stringent requirements are indicated, comply with ASTM E 1637.
- B. Vertical-Rib, Seamed-Joint, Standing-Seam Metal Roof Panels: Formed with vertical ribs at panel edges and flat pan between ribs; designed for sequential installation by mechanically attaching panels to supports using concealed clips located under one side of panels and engaging opposite edge of adjacent panels, and mechanically seaming panels together.
1. Available Manufacturers:
    - a. AEP-Span.
    - b. Englert
    - c. ATAS International, Inc.
    - d. Delcoa Industries, Inc.
    - e. MBCI; Div. of NCI Building Systems.
  2. Material: Aluminum sheet, 0.040 inch (1.02 mm) thick.
    - a. Exterior Finish: 3-coat fluoropolymer.
    - b. Color: To match existing metal roof color on Campus..
  3. Batten: Same material, finish, and color as roof panels.
  4. Clips: Floating to accommodate thermal movement.
    - a. Material: 0.0528-inch- (1.35-mm-) thick, steel sheet.
  5. Joint Type: As standard with manufacturer.
  6. Panel Coverage: 24 inches (610 mm).
  7. Panel Height: 2.0 inches (51 mm).
  8. Uplift Rating: UL 90.

## 2.6 ACCESSORIES

- A. Roof Panel Accessories: Provide components required for a complete metal roof panel assembly including trim, copings, fasciae, corner units, ridge closures, clips, flashings, sealants, gaskets, fillers, closure strips, and similar items. Match material and finish of metal roof panels, unless otherwise indicated.
1. Closures: Provide closures at eaves and ridges, fabricated of same metal as metal roof panels.
  2. Backing Plates: Provide metal backing plates at panel end splices, fabricated from material recommended by manufacturer.
  3. Closure Strips: Closed-cell, expanded, cellular, rubber or crosslinked, polyolefin-foam or closed-cell laminated polyethylene; minimum 1-inch- (25-mm-) thick, flexible closure strips; cut or premolded to match metal roof panel profile. Provide closure strips where indicated or necessary to ensure weathertight construction.
- B. Flashing and Trim: Provide flashing and trim as required to match roof material and to seal against weather and to provide finished appearance. Locations include, but are not limited to, eaves, rakes, corners, bases, framed openings, ridges, fasciae, and fillers. Finish flashing and trim with same finish system as adjacent metal roof panels.



## 2.7 FABRICATION

- A. General: Fabricate and finish metal roof panels and accessories at the factory to greatest extent possible, by manufacturer's standard procedures and processes, as necessary to fulfill indicated performance requirements demonstrated by laboratory testing. Comply with indicated profiles and with dimensional and structural requirements.
- B. Provide panel profile, including major ribs and intermediate stiffening ribs, if any, for full length of panel.
- C. Sheet Metal Accessories: Fabricate flashing and trim to comply with recommendations in SMACNA's "Architectural Sheet Metal Manual" that apply to the design, dimensions, metal, and other characteristics of item indicated.
  - 1. Form exposed sheet metal accessories that are without excessive oil canning, buckling, and tool marks and that are true to line and levels indicated, with exposed edges folded back to form hems.
  - 2. Seams for Aluminum: Fabricate nonmoving seams with flat-lock seams. Form seams and seal with epoxy seam sealer. Rivet joints for additional strength.
  - 3. Seams for Other Than Aluminum: Fabricate nonmoving seams in accessories with flat-lock seams. Tin edges to be seamed, form seams, and solder.
  - 4. Sealed Joints: Form nonexpansion but movable joints in metal to accommodate elastomeric sealant to comply with SMACNA standards.
  - 5. Conceal fasteners and expansion provisions where possible. Exposed fasteners are not allowed on faces of accessories exposed to view.
  - 6. Fabricate cleats and attachment devices from same material as accessory being anchored or from compatible, noncorrosive metal recommended by metal roof panel manufacturer.
    - a. Size: As recommended by SMACNA's "Architectural Sheet Metal Manual" or metal roof panel manufacturer for application but not less than thickness of metal being secured.

## 2.8 FINISHES, GENERAL

- A. Comply with NAAMM's "Metal Finishes Manual for Architectural and Metal Products" for recommendations for applying and designating finishes.
- B. Protect mechanical and painted finishes on exposed surfaces from damage by applying a strippable, temporary protective covering before shipping.
- C. Appearance of Finished Work: Variations in appearance of abutting or adjacent pieces are acceptable if they are within one-half of the range of approved Samples. Noticeable variations in the same piece are not acceptable. Variations in appearance of other components are acceptable if they are within the range of approved Samples and are assembled or installed to minimize contrast.

## PART 3 - EXECUTION

### 3.1 EXAMINATION

- A. Examine substrates, areas, and conditions, with Installer present, for compliance with requirements for installation tolerances, metal roof panel supports, and other conditions affecting performance of work.

1. Examine primary and secondary roof framing to verify that rafters, purlins, angles, channels, and other structural panel support members and anchorages have been installed within alignment tolerances required by metal roof panel manufacturer.
  2. Examine solid roof sheathing to verify that sheathing joints are supported by framing or blocking and that installation is within flatness tolerances required by metal roof panel manufacturer.
  3. For the record, prepare written report, endorsed by Installer, listing conditions detrimental to performance of work.
- B. Examine roughing-in for components and systems penetrating metal roof panels to verify actual locations of penetrations relative to seam locations of metal roof panels before metal roof panel installation.
- C. Proceed with installation only after unsatisfactory conditions have been corrected.

### 3.2 PREPARATION

- A. Clean substrates of substances harmful to insulation, including removing projections capable of interfering with insulation attachment.
- B. Install flashings and other sheet metal to comply with requirements specified in Division 7 Section "Sheet Metal Flashing and Trim."
- C. Install fasciae and copings to comply with requirements specified in Division 7 Section "Sheet Metal Flashing and Trim."
- D. Miscellaneous Framing: Install subpurlins, eave angles, furring, and other miscellaneous roof panel support members and anchorage according to metal roof panel manufacturer's written recommendations.

### 3.3 UNDERLAYMENT INSTALLATION

- A. Self-Adhering Sheet Underlayment: Install self-adhering sheet underlayment, wrinkle free, on roof sheathing under metal roof panels. Apply primer if required by manufacturer. Comply with temperature restrictions of underlayment manufacturer for installation; use primer rather than nails for installing underlayment at low temperatures. Apply over entire roof, in shingle fashion to shed water, with end laps of not less than **6 inches (150 mm)** staggered **24 inches (600 mm)** between courses. Overlap side edges not less than **3-1/2 inches (90 mm)**. Extend underlayment into gutter trough. Roll laps with roller. Cover underlayment within 14 days.
1. Roof perimeter for a distance up from eaves of **24 inches (600 mm)** beyond interior wall line.
  2. Hips and ridges for a distance on each side of **12 inches (300 mm)**.
- B. Install flashings to cover underlayment to comply with requirements specified in Division 7 Section "Sheet Metal Flashing and Trim."
- C. Apply slip sheet over underlayment before installing metal roof panels.

### 3.4 METAL ROOF PANEL INSTALLATION, GENERAL

- A. General: Provide metal roof panels of full length from eave to ridge, unless otherwise indicated or restricted by shipping limitations. Anchor metal roof panels and other components of the Work securely in place, with provisions for thermal and structural movement.
1. Field cutting of metal roof panels by torch is not permitted.
  2. Install panels perpendicular to roof structure.
  3. Rigidly fasten eave end of metal roof panels and allow ridge end free movement due to thermal expansion and contraction. Pre-drill panels.
  4. Provide metal closures at peaks and each side of ridge and hip caps.
  5. Flash and seal metal roof panels with weather closures at eaves, rakes, and at perimeter of all openings. Fasten with self-tapping screws.
  6. Locate and space fastenings in uniform vertical and horizontal alignment.
  7. Install ridge and hip caps as metal roof panel work proceeds.
  8. Locate panel splices over, but not attached to, structural supports. Stagger panel splices and end laps to avoid a four-panel lap splice condition.
  9. Lap metal flashing over metal roof panels to allow moisture to run over and off the material.
- B. Fasteners:
1. Aluminum Roof Panels: Use aluminum or stainless-steel fasteners for surfaces exposed to the exterior and aluminum or galvanized steel fasteners for surfaces exposed to the interior.
  2. Copper Roof Panels: Use copper or stainless-steel fasteners.
  3. Stainless-Steel Roof Panels: Use stainless-steel fasteners.
- C. Metal Protection: Where dissimilar metals will contact each other or corrosive substrates, protect against galvanic action by painting contact surfaces with bituminous coating, by applying rubberized-asphalt underlayment to each contact surface, or by other permanent separation as recommended by metal roof panel manufacturer.
1. Coat back side of aluminum roof panels with bituminous coating where roof panels will contact wood, ferrous metal, or cementitious construction.
- D. Joint Sealers: Install gaskets, joint fillers, and sealants where indicated and where required for weatherproof performance of metal roof panel assemblies. Provide types of gaskets, fillers, and sealants indicated or, if not indicated, types recommended by metal roof panel manufacturer.
1. Seal metal roof panel end laps with double beads of tape or sealant, full width of panel. Seal side joints where recommended by metal roof panel manufacturer.
  2. Prepare joints and apply sealants to comply with requirements in Division 7 Section "Joint Sealants."

### 3.5 FIELD-ASSEMBLED METAL ROOF PANEL INSTALLATION

- A. Standing-Seam Metal Roof Panels: Fasten metal roof panels to supports with concealed clips at each standing-seam joint at location, spacing, and with fasteners recommended by manufacturer.
1. Install clips to supports with self-tapping fasteners.
  2. Install pressure plates at locations indicated in manufacturer's written installation instructions.
  3. Snap Joint: Nest standing seams and fasten together by interlocking and completely engaging factory-applied sealant.
  4. Seamed Joint: Crimp standing seams with manufacturer-approved motorized seamer tool so clip, metal roof panel, and factory-applied sealant are completely engaged.

### 3.6 ACCESSORY INSTALLATION

- A. General: Install accessories with positive anchorage to building and weathertight mounting and provide for thermal expansion. Coordinate installation with flashings and other components.
  - 1. Install components required for a complete metal roof panel assembly including trim, copings, ridge closures, seam covers, flashings, sealants, gaskets, fillers, closure strips, and similar items.
- B. Flashing and Trim: Comply with performance requirements, manufacturer's written installation instructions, and SMACNA's "Architectural Sheet Metal Manual." Provide concealed fasteners where possible, and set units true to line and level as indicated. Install work with laps, joints, and seams that will be permanently watertight and weather resistant.
  - 1. Install exposed flashing and trim that is without excessive oil canning, buckling, and tool marks and that is true to line and levels indicated, with exposed edges folded back to form hems. Install sheet metal flashing and trim to fit substrates and to result in waterproof and weather-resistant performance.
  - 2. Expansion Provisions: Provide for thermal expansion of exposed flashing and trim. Space movement joints at a maximum of **10 feet (3 m)** with no joints allowed within **24 inches (600 mm)** of corner or intersection. Where lapped or bayonet-type expansion provisions cannot be used or would not be sufficiently weather resistant and waterproof, form expansion joints of intermeshing hooked flanges, not less than **1 inch (25 mm)** deep, filled with mastic sealant (concealed within joints).

### 3.7 ERECTION TOLERANCES

- A. Installation Tolerances: Shim and align metal roof panel units within installed tolerance of **1/4 inch in 20 feet (6 mm in 6 m)** on slope and location lines as indicated and within **1/8-inch (3-mm)** offset of adjoining faces and of alignment of matching profiles.

### 3.8 CLEANING AND PROTECTION

- A. Remove temporary protective coverings and strippable films, if any, as metal roof panels are installed, unless otherwise indicated in manufacturer's written installation instructions. On completion of metal roof panel installation, clean finished surfaces as recommended by metal roof panel manufacturer. Maintain in a clean condition during construction.
- B. Replace metal roof panels that have been damaged or have deteriorated beyond successful repair by finish touchup or similar minor repair procedures.

END OF SECTION 07411

## SECTION 07460 – FIBER CEMENT SOFFIT AND TRIM

### PART 1 - GENERAL

#### 1.1 RELATED DOCUMENTS

- A. Drawings and general provisions of the Contract, including General and Supplementary Conditions and Division 1 Specification Sections, apply to this Section.

#### 1.2 SUMMARY

- A. Section Includes: .
  - 1. Fiber-cement soffit and trim material as called out in the construction drawings.

#### 1.3 SUBMITTALS

- A. Product Data: For each type of product indicated. Include construction details, material descriptions, dimensions of individual components and profiles, and finishes.
- B. Samples for Initial Selection: For siding and soffit including related accessories.
- C. Samples for Verification: For each type, color, texture, and pattern required.
  - 1. 12-inch- (300-mm-) long-by-actual-width Sample of siding.
  - 2. 12-inch- (300-mm-) long-by-actual-width Sample of soffit.
  - 3. 12-inch- (300-mm-) long-by-actual-width Samples of trim and accessories.
- D. Product Certificates: For each type of siding and soffit, from manufacturer.
- E. Product Test Reports: Based on evaluation of comprehensive tests performed by a qualified testing agency, for fiber-cement siding.
- F. Maintenance Data: For each type of [siding] [and] [soffit] and related accessories to include in maintenance manuals.
- G. Warranty: Sample of special warranty.

#### 1.4 QUALITY ASSURANCE

- A. Labeling: Provide fiber-cement siding that is tested and labeled according to ASTM C 1186 by a qualified testing agency acceptable to authorities having jurisdiction.
- B. Source Limitations: Obtain each type, color, texture, and pattern of siding and soffit, including related accessories, from single source from single manufacturer.

#### 1.5 DELIVERY, STORAGE, AND HANDLING

- A. Store materials in a dry, well-ventilated, weathertight place.

1.6 COORDINATION

- A. Coordinate installation with flashings and other adjoining construction to ensure proper sequencing.

1.7 WARRANTY

- A. Special Warranty: Standard form in which manufacturer agrees to repair or replace siding and soffit that fail(s) in materials or workmanship within specified warranty period.
  - 1. Failures include, but are not limited to, the following:
    - a. Structural failures including cracking, deforming, and fading.
  - 2. Warranty Period: 10 years from date of Substantial Completion.

1.8 EXTRA MATERIALS

- A. Furnish extra materials that match products installed and that are packaged with protective covering for storage and identified with labels describing contents.
  - 1. Furnish full lengths of trim and soffit including related accessories, in a quantity equal to 2 percent of amount installed.

PART 2 - PRODUCTS

2.1 FIBER-CEMENT SOFFIT

- A. General: ASTM C 1186, Type A, Grade II, fiber-cement board, noncombustible when tested according to ASTM E 136; with a flame-spread index of 25 or less when tested according to ASTM E 84.
  - 1. Manufacturers: Subject to compliance with requirements, available manufacturers offering products that may be incorporated into the Work include, but are not limited to, the following:
    - a. Cemplank.
    - b. GAF Materials Corporation.
    - c. James Hardie.
- B. Pattern: 24-inch- (600-mm-) wide sheets with smooth texture.
- C. Factory Priming: Manufacturer's standard acrylic primer.

2.2 ACCESSORIES

- A. Decorative Accessories: Provide the following fiber-cement decorative accessories as indicated:
  - 1. Fascia.
  - 2. Moldings and trim.
- B. Colors for Decorative Accessories: As selected by Architect from manufacturer's full range of industry colors.

- C. Flashing: Provide stainless-steel flashing complying with Division 7 Section "Sheet Metal Flashing and Trim" at window and door heads and where indicated.
  - 1. Finish for Aluminum Flashing: Siliconized polyester coating, same color as siding.
- D. Fasteners:
  - 1. For fastening to wood, use ribbed bugle-head screws of sufficient length to penetrate a minimum of **1 inch (25 mm)** into substrate.
  - 2. For fastening fiber cement, use stainless-steel fasteners.

### PART 3 - EXECUTION

#### 3.1 EXAMINATION

- A. Examine substrates for compliance with requirements for installation tolerances and other conditions affecting performance of siding and soffit and related accessories.
- B. Proceed with installation only after unsatisfactory conditions have been corrected.

#### 3.2 PREPARATION

- A. Clean substrates of projections and substances detrimental to application.

#### 3.3 INSTALLATION

- A. General: Comply with siding and soffit manufacturer's written installation instructions applicable to products and applications indicated unless more stringent requirements apply.
  - 1. Do not install damaged components.
- B. Install fiber-cement trim and soffit and related accessories.
  - 1. Install fasteners no more than **24 inches (600 mm)** o.c.
- C. Install joint sealants as specified in Division 7 Section "Joint Sealants" and to produce a weathertight installation.

#### 3.4 ADJUSTING AND CLEANING

- A. Remove damaged, improperly installed, or otherwise defective materials and replace with new materials complying with specified requirements.
- B. Clean finished surfaces according to manufacturer's written instructions and maintain in a clean condition during construction.

END OF SECTION 07460

## SECTION 07920 - JOINT SEALANTS

### PART 1 - GENERAL

#### 1.1 RELATED DOCUMENTS

- A. Drawings and general provisions of the Contract, including General and Supplementary Conditions and Division 1 Specification Sections, apply to this Section.

#### 1.2 SUMMARY

- A. This Section includes joint sealants for the following applications, including those specified by reference to this Section: following applications:
  - 1. Exterior joints in the following vertical surfaces and horizontal non-traffic surfaces:
    - a. Construction joints in cast-in-place concrete.
    - b. Joints between different materials listed above.
    - c. Perimeter joints between materials listed above and frames of doors, windows and louvers.
    - d. Control and expansion joints in ceilings and other overhead surfaces.
    - e. Other joints as indicated.
  - 2. Exterior joints in the following horizontal traffic surfaces:
    - a. Isolation and contraction joints in cast-in-place concrete slabs.
    - b. Other joints as indicated.
  - 3. Interior joints in the following vertical surfaces and horizontal nontraffic surfaces:
    - a. Control and expansion joints on exposed interior surfaces of exterior walls.
    - b. Perimeter joints of exterior openings where indicated.
    - c. Vertical joints on exposed surfaces of interior unit masonry concrete walls and partitions.
    - d. Other joints as indicated.
  - 4. Interior joints in the following horizontal traffic surfaces:
    - a. Other joints as indicated.

#### 1.3 PERFORMANCE REQUIREMENTS

- A. Provide elastomeric joint sealants that establish and maintain watertight and airtight continuous joint seals without staining or deteriorating joint substrates.
- B. Provide joint sealants for interior applications that establish and maintain airtight and water-resistant continuous joint seals without staining or deteriorating joint substrates.



#### 1.4 SUBMITTALS

- A. Product Data: For each joint-sealant product indicated.
- B. Samples for Initial Selection: Manufacturer's color charts consisting of strips of cured sealants showing the full range of colors available for each product exposed to view.
- C. Samples for Verification: For each type and color of joint sealant required, provide Samples with joint sealants in **1/2-inch- (13-mm-)** wide joints formed between two **6-inch- (150-mm-)** long strips of material matching the appearance of exposed surfaces adjacent to joint sealants.
- D. Product Certificates: For each type of joint sealant and accessory, signed by product manufacturer.
- E. SWRI Validation Certificate: For each elastomeric sealant specified to be validated by SWRI's Sealant Validation Program.
- F. Qualification Data: For Installer.
- G. Preconstruction Field Test Reports: Indicate which sealants and joint preparation methods resulted in optimum adhesion to joint substrates based on preconstruction testing specified in "Quality Assurance" Article.
- H. Field Test Report Log: For each elastomeric sealant application.
- I. Product Test Reports: Based on comprehensive testing of product formulations performed by a qualified testing agency, indicating that sealants comply with requirements.
- J. Warranties: Special warranties specified in this Section.

#### 1.5 QUALITY ASSURANCE

- A. Installer Qualifications: Manufacturer's authorized Installer who is approved or licensed for installation of elastomeric sealants required for this Project.
- B. Source Limitations: Obtain each type of joint sealant through one source from a single manufacturer.
- C. Product Testing: Obtain test results for "Product Test Reports" Paragraph in "Submittals" Article from a qualified testing agency based on testing current sealant formulations within a 36-month period preceding the Notice to Proceed with commencement of the Work.
  - 1. Testing Agency Qualifications: An independent testing agency qualified according to ASTM C 1021 to conduct the testing indicated, as documented according to ASTM E 548.
  - 2. Test elastomeric joint sealants for compliance with requirements specified by reference to ASTM C 920, and where applicable, to other standard test methods.
  - 3. Test elastomeric joint sealants according to SWRI's Sealant Validation Program for compliance with requirements specified by reference to ASTM C 920 for adhesion and cohesion under cyclic movement, adhesion-in-peel, and indentation hardness.
  - 4. Test other joint sealants for compliance with requirements indicated by referencing standard specifications and test methods.
  - 5. Use ASTM C 1087 to determine whether priming and other specific joint preparation techniques are required to obtain rapid, optimum adhesion of joint sealants to joint substrates.
  - 6. Submit not fewer than eight pieces of each type of material, including joint substrates, shims, joint-sealant backings, secondary seals, and miscellaneous materials.

7. Schedule sufficient time for testing and analyzing results to prevent delaying the Work.
8. For materials failing tests, obtain joint-sealant manufacturer's written instructions for corrective measures including use of specially formulated primers.
9. Testing will not be required if joint-sealant manufacturers submit joint preparation data that are based on previous testing of current sealant products for adhesion to, and compatibility with, joint substrates and other materials matching those submitted.

D. Preconstruction Field-Adhesion Testing: Before installing elastomeric sealants, field test their adhesion to Project joint substrates as follows:

1. Locate test joints where indicated on Project or, if not indicated, as directed by Architect.
2. Conduct field tests for each application indicated below:
  - a. Each type of elastomeric sealant and joint substrate indicated.
  - b. Each type of nonelastomeric sealant and joint substrate indicated.
3. Notify Architect seven days in advance of dates and times when test joints will be erected.
4. Arrange for tests to take place with joint-sealant manufacturer's technical representative present.
  - a. Test Method: Test joint sealants according to Method A, Field-Applied Sealant Joint Hand Pull Tab, in Appendix X1 in ASTM C 1193.
    - 1) For joints with dissimilar substrates, verify adhesion to each substrate separately; extend cut along one side, verifying adhesion to opposite side. Repeat procedure for opposite side
5. Report whether sealant in joint connected to pulled-out portion failed to adhere to joint substrates or tore cohesively. Include data on pull distance used to test each type of product and joint substrate. For sealants that fail adhesively, retest until satisfactory adhesion is obtained.
6. Evaluation of Preconstruction Field-Adhesion-Test Results: Sealants not evidencing adhesive failure from testing, in absence of other indications of noncompliance with requirements, will be considered satisfactory. Do not use sealants that fail to adhere to joint substrates during testing.

E. Mockups: Build mockups incorporating sealant joints, as follows, to verify selections made under sample submittals and to demonstrate aesthetic effects and set quality standards for materials and execution:

1. Joints in mockups of assemblies specified in other Sections that are indicated to receive elastomeric joint sealants, which are specified by reference to this Section.

F. Preinstallation Conference: Conduct conference at Project site to comply with requirements in Division 1 Section "Project Management and Coordination."

## 1.6 PROJECT CONDITIONS

A. Do not proceed with installation of joint sealants under the following conditions:

1. When ambient and substrate temperature conditions are outside limits permitted by joint-sealant manufacturer or are below 40 deg F (5 deg C).
2. When joint substrates are wet.
3. Where joint widths are less than those allowed by joint-sealant manufacturer for applications indicated.
4. Contaminants capable of interfering with adhesion have not yet been removed from joint substrates.

## 1.7 WARRANTY

- A. Special Installer's Warranty: Installer's standard form in which Installer agrees to repair or replace elastomeric joint sealants that do not comply with performance and other requirements specified in this Section within specified warranty period.
  - 1. Warranty Period: two years from date of Substantial Completion.
- B. Special Manufacturer's Warranty: Manufacturer's standard form in which elastomeric sealant manufacturer agrees to furnish elastomeric joint sealants to repair or replace those that do not comply with performance and other requirements specified in this Section within specified warranty period.
  - 1. Warranty Period: 2 years from date of Substantial Completion.
- C. Special warranties specified in this Article exclude deterioration or failure of elastomeric joint sealants from the following:
  - 1. Movement of the structure resulting in stresses on the sealant exceeding sealant manufacturer's written specifications for sealant elongation and compression caused by structural settlement or errors attributable to design or construction.
  - 2. Disintegration of joint substrates from natural causes exceeding design specifications.
  - 3. Mechanical damage caused by individuals, tools, or other outside agents.
  - 4. Changes in sealant appearance caused by accumulation of dirt or other atmospheric contaminants.

## PART 2 - PRODUCTS

### 2.1 MANUFACTURERS

- A. Available Products: Subject to compliance with requirements, products that may be incorporated into the Work include, but are not limited to, products listed in other Part 2 articles.

### 2.2 MATERIALS, GENERAL

- A. Compatibility: Provide joint sealants, backings, and other related materials that are compatible with one another and with joint substrates under conditions of service and application, as demonstrated by sealant manufacturer, based on testing and field experience.
- B. Colors of Exposed Joint Sealants: As selected by Architect from manufacturer's full range.
- C. VOC Content of Interior Sealants: Sealants and sealant primers used inside the weatherproofing system shall comply with the following limits for VOC content when calculated according to 40 CFR 59, Subpart D (EPA Method 24):
  - 1. Architectural Sealants: 250 g/L.
  - 2. Sealant Primers for Nonporous Substrates: 250 g/L.
  - 3. Sealant Primers for Porous Substrates: 775 g/L.
- D. Low-Emitting Interior Sealants: Sealants and sealant primers used inside the weatherproofing system shall comply with the testing and product requirements of the California Department of Health Services' "Standard Practice for the Testing of Volatile Organic Emissions from Various Sources Using Small-Scale Environmental Chambers."

## 2.3 ELASTOMERIC JOINT SEALANTS

- A. Elastomeric Sealants: Comply with ASTM C 920 and other requirements indicated for each liquid-applied chemically curing sealant specified, including those referencing ASTM C 920 classifications for type, grade, class, and uses related to exposure and joint substrates.
- B. Stain-Test-Response Characteristics: Where elastomeric sealants are specified to be nonstaining to porous substrates, provide products that have undergone testing according to ASTM C 1248 and have not stained porous joint substrates indicated for Project.
- C. Suitability for Contact with Food: Where elastomeric sealants are indicated for joints that will come in repeated contact with food, provide products that comply with 21 CFR 177.2600.
- D. Single-Component Nonsag Polysulfide Sealant:
  - 1. Available Products:
    - a. Pacific Polymers, Inc.; Elastoseal 230 Type I (Gun Grade).
    - b. Polymeric Systems Inc.; PSI-7000.
  - 2. Type and Grade: S (single component) and NS (nonsag).
  - 3. Class: 25.
  - 4. Use Related to Exposure: NT (nontraffic).
  - 5. Uses Related to Joint Substrates: M, G, A, and, as applicable to joint substrates indicated, O.
- E. Single-Component Neutral- and Basic-Curing Silicone Sealant:
  - 1. Products:
    - a. Tremco; Spectrem 1 (Basic).
  - 2. Type and Grade: S (single component) and NS (nonsag).
  - 3. Class: 100/50.
  - 4. Use Related to Exposure: NT (nontraffic).
  - 5. Uses Related to Joint Substrates: M, G, A, and, as applicable to joint substrates indicated, O.
  - 6. Stain-Test-Response Characteristics: Nonstaining to porous substrates per ASTM C 1248.

## 2.4 LATEX JOINT SEALANTS

- A. Latex Sealant: Comply with ASTM C 834, Type P, Grade NF.
- B. Available Products:
  - 1. Pecora Corporation; AC-20+.
  - 2. Sonneborn, Division of ChemRex Inc.; Sonolac.
  - 3. Tremco; Tremflex 834.

## 2.5 ACOUSTICAL JOINT SEALANTS

- A. Acoustical Sealant for Concealed Joints: Manufacturer's standard, nondrying, nonhardening, nonskinning, nonstaining, gunnable, synthetic-rubber sealant recommended for sealing interior concealed joints to reduce airborne sound transmission.

1. Available Products:
  - a. Pecora Corporation; BA-98.
  - b. Tremco; Tremco Acoustical Sealant.

## 2.6 PREFORMED JOINT SEALANTS

- A. Preformed Foam Sealant: Manufacturer's standard preformed, precompressed, open-cell foam sealant that is manufactured from high-density urethane foam impregnated with a nondrying, water-repellent agent; is factory produced in precompressed sizes in roll or stick form to fit joint widths indicated; is coated on one side with a pressure-sensitive adhesive and covered with protective wrapping; develops a watertight and airtight seal when compressed to the degree specified by manufacturer; and complies with the following:
  1. Products:
    - a. EMSEAL Joint Systems, Ltd.; Emseal 25V.
    - b. illbruck Sealant Systems, Inc.; Wilseal 600.
    - c. Polytite Manufacturing Corporation; Polytite B.
    - d. Polytite Manufacturing Corporation; Polytite Standard.
    - e. Sandell Manufacturing Co., Inc.; Polyseal.
  2. Properties: Permanently elastic, mildew resistant, nonmigratory, nonstaining, and compatible with joint substrates and other joint sealants.
    - a. Density: 10 lb/cu. ft. (160 kg/cu. m).

## 2.7 JOINT-SEALANT BACKING

- A. General: Provide sealant backings of material and type that are nonstaining; are compatible with joint substrates, sealants, primers, and other joint fillers; and are approved for applications indicated by sealant manufacturer based on field experience and laboratory testing.
- B. Elastomeric Tubing Sealant Backings: Neoprene, butyl, EPDM, or silicone tubing complying with ASTM D 1056, nonabsorbent to water and gas, and capable of remaining resilient at temperatures down to minus 26 deg F (minus 32 deg C). Provide products with low compression set and of size and shape to provide a secondary seal, to control sealant depth, and to otherwise contribute to optimum sealant performance.
- C. Bond-Breaker Tape: Polyethylene tape or other plastic tape recommended by sealant manufacturer for preventing sealant from adhering to rigid, inflexible joint-filler materials or joint surfaces at back of joint where such adhesion would result in sealant failure. Provide self-adhesive tape where applicable.

## 2.8 MISCELLANEOUS MATERIALS

- A. Primer: Material recommended by joint-sealant manufacturer where required for adhesion of sealant to joint substrates indicated, as determined from preconstruction joint-sealant-substrate tests and field tests.

- B. Cleaners for Nonporous Surfaces: Chemical cleaners acceptable to manufacturers of sealants and sealant backing materials, free of oily residues or other substances capable of staining or harming joint substrates and adjacent nonporous surfaces in any way, and formulated to promote optimum adhesion of sealants to joint substrates.
- C. Masking Tape: Nonstaining, nonabsorbent material compatible with joint sealants and surfaces adjacent to joints.

## PART 3 - EXECUTION

### 3.1 EXAMINATION

- A. Examine joints indicated to receive joint sealants, with Installer present, for compliance with requirements for joint configuration, installation tolerances, and other conditions affecting joint-sealant performance.
- B. Proceed with installation only after unsatisfactory conditions have been corrected.

### 3.2 PREPARATION

- A. Surface Cleaning of Joints: Clean out joints immediately before installing joint sealants to comply with joint-sealant manufacturer's written instructions and the following requirements:
  - 1. Remove all foreign material from joint substrates that could interfere with adhesion of joint sealant, including dust, paints (except for permanent, protective coatings tested and approved for sealant adhesion and compatibility by sealant manufacturer), old joint sealants, oil, grease, waterproofing, water repellents, water, surface dirt, and frost.
  - 2. Clean porous joint substrate surfaces by brushing, grinding, blast cleaning, mechanical abrading, or a combination of these methods to produce a clean, sound substrate capable of developing optimum bond with joint sealants. Remove loose particles remaining after cleaning operations above by vacuuming or blowing out joints with oil-free compressed air. Porous joint substrates include the following:
    - a. Concrete.
    - b. Masonry.
  - 3. Remove laitance and form-release agents from concrete.
  - 4. Clean nonporous surfaces with chemical cleaners or other means that do not stain, harm substrates, or leave residues capable of interfering with adhesion of joint sealants. Nonporous joint substrates include the following:
    - a. Metal.
    - b. Glass.
- B. Joint Priming: Prime joint substrates, where recommended in writing by joint-sealant manufacturer, based on preconstruction joint-sealant-substrate tests or prior experience. Apply primer to comply with joint-sealant manufacturer's written instructions. Confine primers to areas of joint-sealant bond; do not allow spillage or migration onto adjoining surfaces.

- C. Masking Tape: Use masking tape where required to prevent contact of sealant with adjoining surfaces that otherwise would be permanently stained or damaged by such contact or by cleaning methods required to remove sealant smears. Remove tape immediately after tooling without disturbing joint seal.

### 3.3 INSTALLATION OF JOINT SEALANTS

- A. General: Comply with joint-sealant manufacturer's written installation instructions for products and applications indicated, unless more stringent requirements apply.
- B. Sealant Installation Standard: Comply with recommendations in ASTM C 1193 for use of joint sealants as applicable to materials, applications, and conditions indicated.
- C. Acoustical Sealant Application Standard: Comply with recommendations in ASTM C 919 for use of joint sealants in acoustical applications as applicable to materials, applications, and conditions indicated.
- D. Install sealant backings of type indicated to support sealants during application and at position required to produce cross-sectional shapes and depths of installed sealants relative to joint widths that allow optimum sealant movement capability.
  - 1. Do not leave gaps between ends of sealant backings.
  - 2. Do not stretch, twist, puncture, or tear sealant backings.
  - 3. Remove absorbent sealant backings that have become wet before sealant application and replace them with dry materials.
- E. Install bond-breaker tape behind sealants where sealant backings are not used between sealants and backs of joints.
- F. Install sealants using proven techniques that comply with the following and at the same time backings are installed:
  - 1. Place sealants so they directly contact and fully wet joint substrates.
  - 2. Completely fill recesses in each joint configuration.
  - 3. Produce uniform, cross-sectional shapes and depths relative to joint widths that allow optimum sealant movement capability.
- G. Tooling of Nonsag Sealants: Immediately after sealant application and before skinning or curing begins, tool sealants according to requirements specified below to form smooth, uniform beads of configuration indicated; to eliminate air pockets; and to ensure contact and adhesion of sealant with sides of joint.
  - 1. Remove excess sealant from surfaces adjacent to joints.
  - 2. Use tooling agents that are approved in writing by sealant manufacturer and that do not discolor sealants or adjacent surfaces.
  - 3. Provide concave joint configuration per Figure 5A in ASTM C 1193, unless otherwise indicated.
  - 4. Provide flush joint configuration where indicated per Figure 5B in ASTM C 1193.
  - 5. Provide recessed joint configuration of recess depth and at locations indicated per Figure 5C in ASTM C 1193.
    - a. Use masking tape to protect surfaces adjacent to recessed tooled joints.
- H. Installation of Preformed Tapes: Install according to manufacturer's written instructions.

- I. Installation of Preformed Foam Sealants: Install each length of sealant immediately after removing protective wrapping, taking care not to pull or stretch material, producing seal continuity at ends, turns, and intersections of joints. For applications at low ambient temperatures where expansion of sealant requires acceleration to produce seal, apply heat to sealant in compliance with sealant manufacturer's written instructions.

### 3.4 FIELD QUALITY CONTROL

- A. Field-Adhesion Testing: Field test joint-sealant adhesion to joint substrates as follows:

1. Extent of Testing: Test completed elastomeric sealant joints as follows:
  - a. Perform 10 tests for the first 1000 feet (300 m) of joint length for each type of elastomeric sealant and joint substrate.
  - b. Perform 1 test for each 1000 feet (300 m) of joint length thereafter or 1 test per each floor per elevation.
2. Test Method: Test joint sealants according to Method A, Field-Applied Sealant Joint Hand Pull Tab in Appendix X1 in ASTM C 1193, as appropriate for type of joint-sealant application indicated.
  - a. For joints with dissimilar substrates, verify adhesion to each substrate separately; do this by extending cut along one side, verifying adhesion to opposite side. Repeat procedure for opposite side.
3. Inspect joints for complete fill, for absence of voids, and for joint configuration complying with specified requirements. Record results in a field-adhesion-test log.
4. Inspect tested joints and report on the following:
  - a. Whether sealants in joints connected to pulled-out portion failed to adhere to joint substrates or tore cohesively. Include data on pull distance used to test each type of product and joint substrate. Compare these results to determine if adhesion passes sealant manufacturer's field-adhesion hand-pull test criteria.
  - b. Whether sealants filled joint cavities and are free of voids.
  - c. Whether sealant dimensions and configurations comply with specified requirements.
5. Record test results in a field-adhesion-test log. Include dates when sealants were installed, names of persons who installed sealants, test dates, test locations, whether joints were primed, adhesion results and percent elongations, sealant fill, sealant configuration, and sealant dimensions.
6. Repair sealants pulled from test area by applying new sealants following same procedures used originally to seal joints. Ensure that original sealant surfaces are clean and that new sealant contacts original sealant.

- B. Evaluation of Field Test Results: Sealants not evidencing adhesive failure from testing or noncompliance with other indicated requirements will be considered satisfactory. Remove sealants that fail to adhere to joint substrates during testing or to comply with other requirements. Retest failed applications until test results prove sealants comply with indicated requirements.



3.5 CLEANING

- A. Clean off excess sealant or sealant smears adjacent to joints as the Work progresses by methods and with cleaning materials approved in writing by manufacturers of joint sealants and of products in which joints occur.

3.6 PROTECTION

- A. Protect joint sealants during and after curing period from contact with contaminating substances and from damage resulting from construction operations or other causes so sealants are without deterioration or damage at time of Substantial Completion. If, despite such protection, damage or deterioration occurs, cut out and remove damaged or deteriorated joint sealants immediately so installations with repaired areas are indistinguishable from original work.

END OF SECTION 07920

## SECTION 08111 - STANDARD STEEL DOORS AND FRAMES

### PART 1 - GENERAL

#### 1.1 RELATED DOCUMENTS

- A. Drawings and general provisions of the Contract, including General and Supplementary Conditions and Division 1 Specification Sections, apply to this Section.

#### 1.2 SUMMARY

- A. This Section includes the following:
  - 1. Standard hollow-metal steel doors.
  - 2. Standard hollow-metal steel frames.
- B. Related Sections include the following:
  - 1. Division 8 Sections for door hardware for standard steel doors.
  - 2. Division 9 painting Sections for field painting standard steel doors and frames.

#### 1.3 DEFINITIONS

- A. Minimum Thickness: Minimum thickness of base metal without coatings.

#### 1.4 SUBMITTALS

- A. Product Data: Include construction details, material descriptions, core descriptions, label compliance, fire-resistance and temperature-rise ratings, and finishes for each type of steel door and frame specified.
- B. Shop Drawings: In addition to requirements below, provide a schedule of standard steel doors and frames using same reference numbers for details and openings as those on Drawings:
  - 1. Elevations of each door design.
  - 2. Details of doors, including vertical and horizontal edge details.
  - 3. Frame details for each frame type, including dimensioned profiles.
  - 4. Details and locations of reinforcement and preparations for hardware.
  - 5. Details of each different wall opening condition.
  - 6. Details of anchorages, accessories, joints, and connections.
  - 7. Details of glazing frames and stops showing glazing.
  - 8. Details of conduit and preparations for electrified door hardware and controls.
- C. Coordination Drawings: Drawings of each opening, including door and frame, drawn to scale and coordinating door hardware. Show elevations of each door design type, showing dimensions, locations of door hardware, and preparations for power, signal, and control systems.
- D. Oversize Construction Certification: For standard steel door assemblies required to be fire rated and exceeding limitations of labeled assemblies; include statement that doors comply with requirements of design, materials, and construction but have not been subjected to fire test.

- E. Product Test Reports: Based on evaluation of comprehensive fire tests performed by a qualified testing agency, for each type of standard steel door and frame.

## 1.5 QUALITY ASSURANCE

- A. Installer Qualifications: An employer of workers trained and approved by manufacturer.
- B. Testing Agency Qualifications: An independent agency qualified according to ASTM E 329 for testing indicated, as documented according to ASTM E 548.
- C. Source Limitations: Obtain standard steel doors and frames through one source from a single manufacturer.
- D. Fire-Rated Door Frame Assemblies: Assemblies complying with NFPA 80 that are listed and labeled by a testing and inspecting agency acceptable to authorities having jurisdiction, for fire-protection ratings indicated.
  - 1. Test Pressure: Test at atmospheric (neutral) pressure according to NFPA 252 or UL 10B.
  - 2. Test Pressure: Test according to NFPA 252 or UL 10C. After 5 minutes into the test, the neutral pressure level in furnace shall be established at 40 inches (1000 mm) or less above the sill.
  - 3. Oversize Fire-Rated Door Assemblies: For units exceeding sizes of tested assemblies, provide certification by a testing agency acceptable to authorities having jurisdiction that doors comply with standard construction requirements for tested and labeled fire-protection-rated door assemblies except for size.
  - 4. Temperature-Rise Rating: At exit enclosures, provide doors that have a temperature-rise rating of 450 deg F (250 deg C) maximum in 30 minutes of fire exposure.

## 1.6 DELIVERY, STORAGE, AND HANDLING

- A. Deliver doors and frames palletized, wrapped, or crated to provide protection during transit and Project-site storage. Do not use nonvented plastic.
- B. Deliver welded frames with two removable spreader bars across bottom of frames, tack welded to jambs and mullions.
- C. Store doors and frames under cover at Project site. Place units in a vertical position with heads up, spaced by blocking, on minimum 4-inch- (102-mm-) high wood blocking. Avoid using nonvented plastic or canvas shelters that could create a humidity chamber.
  - 1. If wrappers on doors become wet, remove cartons immediately. Provide minimum 1/4-inch space between each stacked door to permit air circulation.

## 1.7 PROJECT CONDITIONS

- A. Field Measurements: Verify openings by field measurements before fabrication and indicate measurements on Shop Drawings.

## 1.8 COORDINATION

- A. Coordinate installation of anchorages for standard steel frames. Furnish setting drawings, templates, and directions for installing anchorages, including sleeves, concrete inserts, anchor bolts, and items with integral anchors, that are to be embedded in masonry. Deliver such items to Project site in time for installation.

## PART 2 - PRODUCTS

### 2.1 MANUFACTURERS

- A. Available Manufacturers: Subject to compliance with requirements, manufacturers offering products that may be incorporated into the Work include, but are not limited to, the following:
  - 1. Amweld Building Products, LLC.
  - 2. Ceco Door Products; an ASSA ABLOY Group Company.
  - 3. CURRIES Company; an ASSA ABLOY Group Company.
  - 4. Republic Builders Products Company.
  - 5. Steelcraft; an Ingersoll-Rand Company.

### 2.2 MATERIALS

- A. Metallic-Coated Steel Sheet: ASTM A 653/A 653M, Commercial Steel (CS), Type B; with minimum **A60** zinc-iron-alloy (galvannealed) coating designation.
- B. Electrolytic Zinc-Coated Steel Sheet: ASTM A 591/A 591M, Commercial Steel (CS), Class B coating; mill phosphatized.
- C. Supports and Anchors: After fabricating, galvanize units to be built into exterior walls according to ASTM A 153/A 153M, Class B.
- D. Inserts, Bolts, and Fasteners: Provide items to be built into exterior walls, hot-dip galvanized according to ASTM A 153/A 153M.
- E. Powder-Actuated Fasteners in Concrete: Fastener system of type suitable for application indicated, fabricated from corrosion-resistant materials, with clips or other accessory devices for attaching standard steel door frames of type indicated.
- F. Mineral-Fiber Insulation: ASTM C 665, Type I (blankets without membrane facing); consisting of fibers manufactured from slag or rock wool with **6- to 12-lb/cu. ft. (96- to 192-kg/cu. m)** density; with maximum flame-spread and smoke-developed indexes of 25 and 50 respectively; passing ASTM E 136 for combustion characteristics.
- G. Glazing: Comply with requirements in Division 8 Section "Glazing."
- H. Bituminous Coating: Cold-applied asphalt mastic, SSPC-Paint 12, compounded for **15-mil (0.4-mm)** dry film thickness per coat. Provide inert-type noncorrosive compound free of asbestos fibers, sulfur components, and other deleterious impurities.

## 2.3 STANDARD STEEL DOORS

- A. General: Provide doors of design indicated, not less than thickness indicated; fabricated with smooth surfaces, without visible joints or seams on exposed faces, unless otherwise indicated. Comply with ANSI A250.8.
1. Design: Flush panel.
  2. Core Construction: Manufacturer's standard kraft-paper honeycomb, polystyrene, polyurethane, mineral-board, or vertical steel-stiffener core that produces doors complying with ANSI A250.8.
    - a. Fire Door Core: As required to provide fire-protection and temperature-rise ratings indicated.
    - b. Thermal-Rated (Insulated) Doors: Where indicated, provide doors fabricated with thermal-resistance value (R-value) of not less than **6.0 deg F x h x sq. ft./Btu (1.057 K x sq. m/W)** when tested according to ASTM C 1363.
      - 1) Locations: Exterior doors and interior doors where indicated.
  3. Vertical Edges for Single-Acting Doors: Square edge.
    - a. Beveled Edge: **1/8 inch in 2 inches (3 mm in 50 mm)**.
  4. Vertical Edges for Double-Acting Doors: Round vertical edges with **2-1/8-inch (54-mm)** radius.
  5. Top and Bottom Edges: Closed with flush or inverted **0.042-inch- (1.0-mm-)** thick end closures or channels of same material as face sheets.
  6. Tolerances: Comply with SDI 117, "Manufacturing Tolerances for Standard Steel Doors and Frames."
- B. Exterior Doors: Face sheets fabricated from metallic-coated steel sheet. Provide doors complying with requirements indicated below by referencing ANSI A250.8 for level and model and ANSI A250.4 for physical-endurance level:
1. Level 4 and Physical Performance Level B (Heavy Duty), Model 1 (Full Flush).
- C. Interior Doors: Face sheets fabricated from cold-rolled steel sheet, unless otherwise indicated to comply with exterior door requirements. Provide doors complying with requirements indicated below by referencing ANSI A250.8 for level and model and ANSI A250.4 for physical-endurance level:
1. Level 3 and Physical Performance Level B (Heavy Duty), Model 1 (Full Flush).
- D. Hardware Reinforcement: Fabricate reinforcement plates from same material as door face sheets to comply with the following minimum sizes:
1. Hinges: Minimum **0.123 inch (3.0 mm)** thick by **1-1/2 inches (38 mm)** wide by **6 inches (152 mm)** longer than hinge, secured by not less than 6 spot welds.
  2. Pivots: Minimum **0.167 inch (4.2 mm)** thick by **1-1/2 inches (38 mm)** wide by **6 inches (152 mm)** longer than hinge, secured by not less than 6 spot welds.
  3. Lock Face, Flush Bolts, Closers, and Concealed Holders: Minimum **0.067 inch (1.7 mm)** thick.
  4. All Other Surface-Mounted Hardware: Minimum **0.067 inch (1.7 mm)** thick.
- E. Fabricate concealed stiffeners and hardware reinforcement from either cold- or hot-rolled steel sheet.

## 2.4 STANDARD STEEL FRAMES

- A. General: Comply with ANSI A250.8 and with details indicated for type and profile.
- B. Exterior Frames: Fabricated from metallic-coated steel sheet.
  - 1. Fabricate frames with mitered or coped and welded face corners and seamless face joints.
  - 2. Frames for Level 4 Steel Doors: **0.078-inch** thick steel sheet, unless otherwise indicated.
- C. Interior Frames: Fabricated from cold-rolled steel sheet, unless otherwise indicated to comply with exterior frame requirements.
  - 1. Fabricate frames with mitered or coped and welded face corners and seamless face joints, unless otherwise indicated.
  - 2. Fabricate knocked-down frames with mitered or coped corners, for field assembly.
  - 3. Frames for Level 3 Steel Doors: **0.063-inch** thick steel sheet, unless otherwise indicated.
  - 4. Frames for Wood Doors: **0.063-inch** thick steel sheet.
  - 5. Frames for Borrowed Lights: **0.052-inch-** thick steel sheet.
- D. Hardware Reinforcement: Fabricate reinforcement plates from same material as frames to comply with the following minimum sizes:
  - 1. Hinges: Minimum **0.123 inch (3.0 mm)** thick by **1-1/2 inches (38 mm)** wide by **6 inches (152 mm)** longer than hinge, secured by not less than 6 spot welds.
  - 2. Pivots: Minimum **0.167 inch (4.2 mm)** thick by **1-1/2 inches (38 mm)** wide by **6 inches (152 mm)** longer than hinge, secured by not less than 6 spot welds.
  - 3. Lock Face, Flush Bolts, Closers, and Concealed Holders: Minimum **0.067 inch (1.7 mm)** thick.
  - 4. All Other Surface-Mounted Hardware: Minimum **0.067 inch (1.7 mm)** thick.
- E. Supports and Anchors: Fabricated from electrolytic zinc-coated or metallic-coated steel sheet.
- F. Jamb Anchors:
  - 1. Masonry Type: Adjustable strap-and-stirrup or T-shaped anchors to suit frame size, not less than **0.042 inch (1.0 mm)** thick, with corrugated or perforated straps not less than **2 inches (50 mm)** wide by **10 inches (250 mm)** long; or wire anchors not less than **0.177 inch (4.5 mm)** thick.
  - 2. Stud-Wall Type: Designed to engage stud, welded to back of frames; not less than **0.042 inch (1.0 mm)** thick.
- G. Floor Anchors: Formed from same material as frames, not less than **0.042 inch (1.0 mm)** thick, and as follows:
  - 1. Monolithic Concrete Slabs: Clip-type anchors, with two holes to receive fasteners.
  - 2. Separate Topping Concrete Slabs: Adjustable-type anchors with extension clips, allowing not less than **2-inch (50-mm)** height adjustment. Terminate bottom of frames at finish floor surface.
- H. Fabricate concealed stiffeners and hardware reinforcement from either cold- or hot-rolled steel sheet.

## 2.5 STOPS AND MOLDINGS

- A. Moldings for Glazed Lites in Doors: Minimum **0.032 inch (0.8 mm)** thick, fabricated from same material as door face sheet in which they are installed.
- B. Fixed Frame Moldings: Formed integral with standard steel frames, minimum **5/8 inch (16 mm)** high, unless otherwise indicated.
- C. Loose Stops for Glazed Lites in Frames: Minimum **0.032 inch (0.8 mm)** thick, fabricated from same material as frames in which they are installed.

## 2.6 FABRICATION

- A. General: Fabricate standard steel doors and frames to be rigid and free of defects, warp, or buckle. Accurately form metal to required sizes and profiles, with minimum radius for thickness of metal. Where practical, fit and assemble units in manufacturer's plant. To ensure proper assembly at Project site, clearly identify work that cannot be permanently factory assembled before shipment.
- B. Standard Steel Doors:
  - 1. Exterior Doors: Provide weep-hole openings in bottom of exterior doors to permit moisture to escape. Seal joints in top edges of doors against water penetration.
  - 2. Glazed Lites: Factory cut openings in doors.
- C. Standard Steel Frames: Where frames are fabricated in sections due to shipping or handling limitations, provide alignment plates or angles at each joint, fabricated of same thickness metal as frames.
  - 1. Welded Frames: Weld flush face joints continuously; grind, fill, dress, and make smooth, flush, and invisible.
  - 2. Provide countersunk, flat- or oval-head exposed screws and bolts for exposed fasteners, unless otherwise indicated.
  - 3. Floor Anchors: Weld anchors to bottom of jambs and mullions with at least four spot welds per anchor.
  - 4. Jamb Anchors: Provide number and spacing of anchors as follows:
    - a. Masonry Type: Locate anchors not more than **18 inches (457 mm)** from top and bottom of frame. Space anchors not more than **32 inches (813 mm)** o.c. and as follows:
      - 1) Two anchors per jamb up to **60 inches (1524 mm)** in height.
      - 2) Three anchors per jamb from **60 to 90 inches (1524 to 2286 mm)** in height.
      - 3) Four anchors per jamb from **90 to 120 inches (2286 to 3048 mm)** in height.
      - 4) Four anchors per jamb plus 1 additional anchor per jamb for each **24 inches (610 mm)** or fraction thereof more than **120 inches (3048 mm)** in height.
    - b. Stud-Wall Type: Locate anchors not more than **18 inches (457 mm)** from top and bottom of frame. Space anchors not more than **32 inches (813 mm)** o.c. and as follows:
      - 1) Three anchors per jamb up to **60 inches (1524 mm)** in height.
      - 2) Four anchors per jamb from **60 to 90 inches (1524 to 2286 mm)** in height.
      - 3) Five anchors per jamb from **90 to 96 inches (2286 to 2438 mm)** in height.
      - 4) Five anchors per jamb plus 1 additional anchor per jamb for each **24 inches (610 mm)** or fraction thereof more than **96 inches (2438 mm)** in height.
      - 5) Two anchors per head for frames more than **42 inches (1066 mm)** wide and mounted in metal-stud partitions.

5. Door Silencers: Except on weather-stripped doors, drill stops to receive door silencers as follows. Provide plastic plugs to keep holes clear during construction.
  - a. Single-Door Frames: Drill stop in strike jamb to receive three door silencers.
  - b. Double-Door Frames: Drill stop in head jamb to receive two door silencers.
  
- D. Hardware Preparation: Factory prepare standard steel doors and frames to receive templated mortised hardware; include cutouts, reinforcement, mortising, drilling, and tapping, according to the Door Hardware Schedule and templates furnished as specified in Division 8 Section "Door Hardware."
  1. Reinforce doors and frames to receive nontemplated mortised and surface-mounted door hardware.
  2. Comply with applicable requirements in ANSI A250.6 and ANSI/DHI A115 Series specifications for door and frame preparation for hardware. Locate hardware as indicated on Shop Drawings or, if not indicated, according to ANSI A250.8.
  
- E. Stops and Moldings: Provide stops and moldings around glazed lites where indicated. Form corners of stops and moldings with butted or mitered hairline joints.
  1. Single Glazed Lites: Provide fixed stops and moldings welded on secure side of door or frame.
  2. Multiple Glazed Lites: Provide fixed and removable stops and moldings such that each glazed lite is capable of being removed independently.
  3. Provide fixed frame moldings on outside of exterior and on secure side of interior doors and frames.
  4. Provide loose stops and moldings on inside of doors and frames.
  5. Coordinate rabbet width between fixed and removable stops with type of glazing and type of installation indicated.

## 2.7 STEEL FINISHES

- A. General: Comply with NAAMM's "Metal Finishes Manual for Architectural and Metal Products" for recommendations for applying and designating finishes.
  1. Finish standard steel door and frames after assembly.
  
- B. Metallic-Coated Steel Surface Preparation: Clean surfaces with nonpetroleum solvent so surfaces are free of oil and other contaminants. After cleaning, apply a conversion coating suited to the organic coating to be applied over it. Clean welds, mechanical connections, and abraded areas, and apply galvanizing repair paint specified below to comply with ASTM A 780.
  1. Galvanizing Repair Paint: High-zinc-dust-content paint for reglazing welds in steel, complying with SSPC-Paint 20.
  
- C. Steel Surface Preparation: Clean surfaces to comply with SSPC-SP 1, "Solvent Cleaning"; remove dirt, oil, grease, or other contaminants that could impair paint bond. Remove mill scale and rust, if present, from uncoated steel; comply with SSPC-SP 3, "Power Tool Cleaning," or SSPC-SP 6/NACE No. 3, "Commercial Blast Cleaning."



- D. Factory Priming for Field-Painted Finish: Apply shop primer specified below immediately after surface preparation and pretreatment. Apply a smooth coat of even consistency to provide a uniform dry film thickness of not less than **0.7 mils (0.018 mm)**.
1. Shop Primer: Manufacturer's standard, fast-curing, lead- and chromate-free primer complying with ANSI A250.10 acceptance criteria; recommended by primer manufacturer for substrate; compatible with substrate and field-applied finish paint system indicated; and providing a sound foundation for field-applied topcoats despite prolonged exposure.

## PART 3 - EXECUTION

### 3.1 EXAMINATION

- A. Examine substrates, areas, and conditions, with Installer present, for compliance with requirements for installation tolerances and other conditions affecting performance of standard steel doors and frames.
1. Examine roughing-in for embedded and built-in anchors to verify actual locations of standard steel frame connections before frame installation.
  2. For the record, prepare written report, endorsed by Installer, listing conditions detrimental to performance of work.
  3. Proceed with installation only after unsatisfactory conditions have been corrected.

### 3.2 PREPARATION

- A. Remove welded-in shipping spreaders installed at factory.
- B. Prior to installation and with installation spreaders in place, adjust and securely brace standard steel door frames for squareness, alignment, twist, and plumb to the following tolerances:
1. Squareness: Plus or minus **1/16 inch (1.6 mm)**, measured at door rabbet on a line 90 degrees from jamb perpendicular to frame head.
  2. Alignment: Plus or minus **1/16 inch (1.6 mm)**, measured at jambs on a horizontal line parallel to plane of wall.
  3. Twist: Plus or minus **1/16 inch (1.6 mm)**, measured at opposite face corners of jambs on parallel lines, and perpendicular to plane of wall.
  4. Plumbness: Plus or minus **1/16 inch (1.6 mm)**, measured at jambs on a perpendicular line from head to floor.
- C. Drill and tap doors and frames to receive nontemplated mortised and surface-mounted door hardware.

### 3.3 INSTALLATION

- A. General: Provide doors and frames of sizes, thicknesses, and designs indicated. Install standard steel doors and frames plumb, rigid, properly aligned, and securely fastened in place; comply with Drawings and manufacturer's written instructions.

- B. Standard Steel Frames: Install standard steel frames for doors and borrowed lights and other openings, of size and profile indicated. Comply with SDI 105.
1. Set frames accurately in position; plumbed, aligned, and braced securely until permanent anchors are set. After wall construction is complete, remove temporary braces, leaving surfaces smooth and undamaged.
    - a. At fire-protection-rated openings, install frames according to NFPA 80.
    - b. Where frames are fabricated in sections due to shipping or handling limitations, field splice at approved locations by welding face joint continuously; grind, fill, dress, and make splice smooth, flush, and invisible on exposed faces.
    - c. Install frames with removable glazing stops located on secure side of opening.
    - d. Install door silencers in frames before grouting.
    - e. Remove temporary braces necessary for installation only after frames have been properly set and secured.
    - f. Check plumb, squareness, and twist of frames as walls are constructed. Shim as necessary to comply with installation tolerances.
    - g. Apply bituminous coating to backs of frames that are filled with mortar, grout, and plaster containing antifreezing agents.
  2. Floor Anchors: Provide floor anchors for each jamb and mullion that extends to floor and secure with postinstalled expansion anchors.
    - a. Floor anchors may be set with powder-actuated fasteners instead of postinstalled expansion anchors if so indicated and approved on Shop Drawings.
  3. Masonry Walls: Coordinate installation of frames to allow for solidly filling space between frames and masonry with mortar as specified in Division 4 Section "Unit Masonry Assemblies."
  4. Installation Tolerances: Adjust standard steel door frames for squareness, alignment, twist, and plumb to the following tolerances:
    - a. Squareness: Plus or minus **1/16 inch (1.6 mm)**, measured at door rabbet on a line 90 degrees from jamb perpendicular to frame head.
    - b. Alignment: Plus or minus **1/16 inch (1.6 mm)**, measured at jambs on a horizontal line parallel to plane of wall.
    - c. Twist: Plus or minus **1/16 inch (1.6 mm)**, measured at opposite face corners of jambs on parallel lines, and perpendicular to plane of wall.
    - d. Plumbness: Plus or minus **1/16 inch (1.6 mm)**, measured at jambs at floor.
- C. Standard Steel Doors: Fit hollow-metal doors accurately in frames, within clearances specified below. Shim as necessary.
1. Non-Fire-Rated Standard Steel Doors:
    - a. Jambs and Head: **1/8 inch (3 mm)** plus or minus **1/16 inch (1.6 mm)**.
    - b. Between Edges of Pairs of Doors: **1/8 inch (3 mm)** plus or minus **1/16 inch (1.6 mm)**.
    - c. Between Bottom of Door and Top of Threshold: Maximum **3/8 inch (9.5 mm)**.
    - d. Between Bottom of Door and Top of Finish Floor (No Threshold): Maximum **3/4 inch (19 mm)**.
  2. Fire-Rated Doors: Install doors with clearances according to NFPA 80.

- D. Glazing: Comply with installation requirements in Division 8 Section "Glazing" and with standard steel door and frame manufacturer's written instructions.
  - 1. Secure stops with countersunk flat- or oval-head machine screws spaced uniformly not more than **9 inches (230 mm)** o.c., and not more than **2 inches (50 mm)** o.c. from each corner.

#### 3.4 ADJUSTING AND CLEANING

- A. Final Adjustments: Check and readjust operating hardware items immediately before final inspection. Leave work in complete and proper operating condition. Remove and replace defective work, including standard steel doors or frames that are warped, bowed, or otherwise unacceptable.
- B. Clean grout and other bonding material off standard steel doors and frames immediately after installation.
- C. Prime-Coat Touchup: Immediately after erection, sand smooth rusted or damaged areas of prime coat and apply touchup of compatible air-drying primer.
- D. Galvanized Surfaces: Clean abraded areas and repair with galvanizing repair paint according to manufacturer's written instructions.

END OF SECTION 08111

## SECTION 08331 - OVERHEAD COILING DOORS

### PART 1 - GENERAL

#### 1.1 RELATED DOCUMENTS

- A. Drawings and general provisions of the Contract, including General and Supplementary Conditions and Division 1 Specification Sections, apply to this Section.

#### 1.2 SUMMARY

- A. This Section includes the following types of manually operated overhead coiling doors:
  - 1. Insulated Crank Operated Rolling Door
- B. Related Sections include the following:
  - 1. Division 8 Section "Door Hardware" for lock cylinders and keying.

#### 1.3 DEFINITIONS

- A. Operation Cycle: One cycle of a door is complete when it is moved from the closed position to the fully open position and returned to the closed position.

#### 1.4 PERFORMANCE REQUIREMENTS

- A. Structural Performance: Provide overhead coiling doors capable of withstanding the effects of gravity loads and the following loads and stresses without evidencing permanent deformation of door components:
  - 1. Wind Load: Uniform pressure (velocity pressure) as require for 140 MPH. See structural engineering drawings for wind loads and pressures.
  - 2. Impact Test for Flying Debris: Comply with ASTM E 1996, tested according to ASTM E 1886.
    - a. Level of Protection: Enhanced Protection.
- B. Operation-Cycle Requirements: Provide overhead coiling door components and operators capable of operating for not less than 20,000 cycles and for 10 cycles per day.
  - 1. Include tamperproof cycle counter.

#### 1.5 SUBMITTALS

- A. Product Data: For each type and size of overhead coiling door and accessory. Include the following:
  - 1. Summary of forces and loads on walls and jambs.

- B. Shop Drawings: For special components and installations not dimensioned or detailed in manufacturer's product data.
- C. Samples for Initial Selection: Manufacturer's color charts showing full range of colors available for units with factory-applied finishes.
- D. Samples for Verification: Of each type of exposed finish required, prepared on Samples of size indicated below.
  - 1. Curtain Slats: 12 inches (305 mm) long.
  - 2. Bottom Bar: 6 inches (150 mm) long.
  - 3. Guides: 6 inches (150 mm) long.
  - 4. Brackets: 6 inches (150 mm) square.
  - 5. Hood: 6 inches (150 mm) square.
- E. Qualification Data: For Installer.

## 1.6 QUALITY ASSURANCE

- A. Installer Qualifications: Manufacturer's authorized representative who is trained and approved for both installation and maintenance of units required for this Project.
- B. Source Limitations: Obtain overhead coiling doors through one source from a single manufacturer.
  - 1. Obtain operators and controls from overhead coiling door manufacturer.

## PART 2 - PRODUCTS

### 2.1 MANUFACTURERS

- A. Available Manufacturers: Subject to compliance with requirements, manufacturers offering products that may be incorporated into the Work include, but are not limited to, the following:
  - 1. Atlas Door; Div. of Clopay Building Products Company, Inc.
  - 2. Cookson Company.
  - 3. Cornell Iron Works Inc.
  - 4. Overhead Door Corp.
  - 5. Raynor.
  - 6. Wayne-Dalton Corp.

### 2.2 DOOR CURTAIN MATERIALS AND CONSTRUCTION

- A. Door Curtains: Fabricate overhead coiling door curtain of interlocking slats, designed to withstand wind loading indicated, in a continuous length for width of door without splices. Unless otherwise indicated, provide slats of thickness and mechanical properties recommended by door manufacturer for performance, size, and type of door indicated, and as follows:
  - 1. Aluminum Door Curtain Slats: ASTM B 209 (ASTM B 209M) or ASTM B 221 (ASTM B 221M), alloy and temper recommended by aluminum producer and finisher for type of use and finish indicated.

- a. Aluminum Extrusion Thickness: Not less than 0.051 inch (1.30 mm).
  - b. Curved profile slats.
2. Insulation: Fill slat with manufacturer's standard rigid cellular polystyrene or polyurethane-foam-type thermal insulation complying with maximum flame-spread and smoke-developed indexes of 75 and 450, respectively, according to ASTM E 84. Enclose insulation completely within metal slat faces.
  3. Inside Curtain Slat Face: To match material of outside metal curtain slat.
- B. Endlocks and Windlocks for Service Doors: Malleable-iron casings galvanized after fabrication, secured to curtain slats with galvanized rivets or high-strength nylon. Provide locks on not less than alternate curtain slats for curtain alignment and resistance against lateral movement.
  - C. Endlocks for Counter Doors: Manufacturer's standard locks on not less than alternate curtain slats for curtain alignment and resistance against lateral movement.
  - D. Bottom Bar for Counter Doors: Manufacturer's standard continuous channel or tubular shape, either stainless-steel or aluminum extrusions to suit type of curtain slats.
    1. Astragal: Provide a replaceable, adjustable, continuous, compressible gasket of flexible vinyl, rubber, or neoprene; for placement between angles or fitted to shape, as a cushion bumper for interior door.
  - E. Curtain Jamb Guides for Counter Doors: Fabricate curtain jamb guides of of material and finish to match curtain slats, with sufficient depth and strength to retain curtain, to allow curtain to operate smoothly, and to withstand loading. Provide continuous integral wear strips to prevent metal-to-metal contact and to minimize operational noise; with removable stops on guides to prevent overtravel of curtain.
    1. Removable Posts and Jamb Guides: Manufacturer's standard.

## 2.3 HOODS AND ACCESSORIES

- A. Hood: Form to act as weatherseal and entirely enclose coiled curtain and operating mechanism at opening head. Contour to fit end brackets to which hood is attached. Roll and reinforce top and bottom edges for stiffness. Provide closed ends for surface-mounted hoods and provide fascia for any portion of between-jamb mounting projecting beyond wall face. Provide intermediate support brackets as required to prevent sagging.
  1. Fabricate hoods for aluminum doors, alloy and temper recommended by aluminum producer and finisher for type of use and finish indicated; 0.032-inch (0.8-mm) minimum thickness, complying with ASTM B 209 (ASTM B 209M).
  2. Shape: Square.
  3. Exterior-Mounted Door: Fabricate hood with sealant-joint bead profile for applying joint sealant.
- B. Integral Frame, Hood, and Fascia: Provide welded assemblies of the following sheet metal:
  1. Fabricate from minimum 0.064-inch- (1.6-mm-) thick, hot-dip galvanized steel sheet with G90 (Z275) zinc coating, complying with ASTM A 653/A 653M.
  2. Fabricate from minimum 0.0625-inch- (1.6-mm-) thick stainless-steel sheet, Type 304, complying with ASTM A 240/A 240M or ASTM A 666.
- C. Integral Sills: Fabricate sills as integral part of frame assembly of same sheet metal; 0.078-inch (2.0-mm) minimum thickness.

- D. Weatherseals: Provide replaceable, adjustable, continuous, compressible weather-stripping gaskets fitted to bottom and top of exterior doors, unless otherwise indicated. At door head, use **1/8-inch- (3-mm-)** thick, replaceable, continuous sheet secured to inside of hood.
  - 1. In addition, provide replaceable, adjustable, continuous, flexible, **1/8-inch- (3-mm-)** thick seals of flexible vinyl, rubber, or neoprene at door jambs for a weathertight installation.
- E. Slide Bolt: Fabricate with side-locking bolts to engage through slots in tracks for locking by padlock, located on both left and right jamb sides, operable from coil side.
- F. Fabricate locking device assembly with lock, spring-loaded dead bolt, operating handle, cam plate, and adjustable locking bar to engage through slots in tracks.
  - 1. Locking Bars: Single-jamb side operable from.
  - 2. Lock cylinder is specified in Division 8 Section "Door Hardware."
- G. Chain Lock Keeper: Suitable for padlock.

#### 2.4 COUNTERBALANCING MECHANISM

- A. General: Counterbalance doors by means of adjustable-tension, steel helical torsion spring mounted around a steel shaft and contained in a spring barrel connected to door curtain with barrel rings. Use grease-sealed bearings or self-lubricating graphite bearings for rotating members.
- B. Counterbalance Barrel: Fabricate spring barrel of hot-formed, structural-quality, welded or seamless carbon-steel pipe, of sufficient diameter and wall thickness to support rolled-up curtain without distortion of slats and to limit barrel deflection to not more than **0.03 in./ft. (2.5 mm/m)** of span under full load.
- C. Provide spring balance of one or more oil-tempered, heat-treated steel helical torsion springs. Size springs to counterbalance weight of curtain, with uniform adjustment accessible from outside barrel. Provide cast-steel barrel plugs to secure ends of springs to barrel and shaft.
- D. Fabricate torsion rod for counterbalance shaft of cold-rolled steel, sized to hold fixed spring ends and carry torsional load.
- E. Brackets: Provide mounting brackets of manufacturer's standard design, either cast iron or cold-rolled steel plate.

#### 2.5 FINISHES, GENERAL

- A. General: Comply with NAAMM's "Metal Finishes Manual for Architectural and Metal Products" for recommendations for applying and designating finishes.
- B. Appearance of Finished Work: Variations in appearance of abutting or adjacent pieces are acceptable if they are within one-half of the range of approved Samples. Noticeable variations in the same piece are not acceptable. Variations in appearance of other components are acceptable if they are within the range of approved Samples and are assembled or installed to minimize contrast.

#### 2.6 ALUMINUM FINISHES

- A. Finish designations prefixed by AA comply with the system established by the Aluminum Association for designating aluminum finishes.

- B. Powder-Coat Finish: Manufacturer's standard powder-coat finish consisting of primer and topcoat according to coating manufacturer's written instructions for cleaning, pretreatment, application, thermosetting, and minimum dry film thickness.
  - 1. Color and Gloss: As selected by Architect from manufacturer's full range.

## PART 3 - EXECUTION

### 3.1 INSTALLATION

- A. General: Install coiling doors and operating equipment complete with necessary hardware, jamb and head molding strips, anchors, inserts, hangers, and equipment supports.

### 3.2 ADJUSTING

- A. Lubricate bearings and sliding parts; adjust doors to operate easily, free of warp, twist, or distortion and with weathertight fit around entire perimeter.

### 3.3 STARTUP SERVICES

- A. Engage a factory-authorized service representative to perform startup service.
  - 1. Complete installation and startup checks according to manufacturer's written instructions.
  - 2. Test and adjust controls and safeties. Replace damaged and malfunctioning controls and equipment.

### 3.4 DEMONSTRATION

- A. Engage a factory-authorized service representative to train Owner's maintenance personnel to adjust, operate, and maintain overhead coiling doors.

END OF SECTION 08331



## SECTION 08411 - ALUMINUM-FRAMED STOREFRONTS

### PART 1 - GENERAL

#### 1.1 RELATED DOCUMENTS

- A. Drawings and Technical Provisions of the Contract, including General and Supplementary Conditions and Division 0 Specification Sections, apply to this Section.

#### 1.2 SUMMARY

- A. This Section includes the following:

- 1. Exterior aluminum-framed storefronts.
  - a. Glazing is retained mechanically with gaskets on four sides.

- B. Related Sections include the following:

- 1. Division 7 Section "Joint Sealants" for installation of joint sealants installed with aluminum-framed systems and for sealants to the extent not specified in this Section.
- 2. Division 8 Section "Finish Hardware" for hardware to the extent not specified in this Section.

#### 1.3 PERFORMANCE REQUIREMENTS

- A. General: Provide aluminum-framed systems, including anchorage, capable of withstanding, without failure, the effects of the following:

- 1. Structural loads.
- 2. Thermal movements.
- 3. Movements of supporting structure indicated on Drawings including, but not limited to, story drift and deflection from uniformly distributed and concentrated live loads.
- 4. Dimensional tolerances of building frame and other adjacent construction.
- 5. Failure includes the following:
  - a. Deflection exceeding specified limits.
  - b. Thermal stresses transferred to building structure.
  - c. Framing members transferring stresses, including those caused by thermal and structural movements, to glazing.
  - d. Noise or vibration created by wind and thermal and structural movements.
  - e. Loosening or weakening of fasteners, attachments, and other components.
  - f. Sealant failure.
  - g. Failure of operating units to function properly.

- B. Structural Loads:

- 1. Wind Loads: As indicated on Structural Drawings.

- C. Deflection of Framing Members:
1. Deflection Normal to Wall Plane: Limited to 1/175 of clear span for spans up to 13 feet 6 inches (4.1 m) and to 1/240 of clear span plus 1/4 inch (6.35 mm) for spans greater than 13 feet 6 inches (4.1 m) or an amount that restricts edge deflection of individual glazing lites to 3/4 inch (19 mm), whichever is less.
  2. Deflection Parallel to Glazing Plane: Limited to 1/360 of clear span or 1/8 inch (3.2 mm), whichever is smaller.
- D. Structural-Test Performance: Provide aluminum-framed systems tested according to ASTM E 330 as follows:
1. When tested at positive and negative wind-load design pressures, systems do not evidence deflection exceeding specified limits.
  2. When tested at 150 percent of positive and negative wind-load design pressures, systems, including anchorage, do not evidence material failures, structural distress, and permanent deformation of main framing members exceeding 0.2 percent of span.
  3. Test Durations: As required by design wind velocity but not less than 10 seconds.
- E. Windborne-Debris-Impact-Resistance-Test Performance: Provide aluminum-framed systems that pass large and small missile-impact tests and cyclic-pressure tests according to the Florida Building Code.
- F. Thermal Movements: Provide aluminum-framed systems that allow for thermal movements resulting from the following maximum change (range) in ambient and surface temperatures. Base engineering calculation on surface temperatures of materials due to both solar heat gain and nighttime-sky heat loss.
1. Temperature Change (Range): 120 deg F (67 deg C), ambient; 180 deg F (100 deg C), material surfaces.
- G. Air Infiltration: Provide aluminum-framed systems with maximum air leakage through fixed glazing and framing areas of 0.06 cfm/sq. ft. (0.03 L/s per sq. m) of fixed wall area when tested according to ASTM E 283 at a minimum static-air-pressure difference of 1.57 lbf/sq. ft. (75 Pa).
- H. Water Penetration Under Static Pressure: Provide aluminum-framed systems that do not evidence water penetration through fixed glazing and framing areas when tested according to ASTM E 331 at a minimum static-air-pressure difference of 20 percent of positive wind-load design pressure, but not less than 6.24 lbf/sq. ft. (300 Pa).
1. Maximum Water Leakage: According to AAMA 501.1. Water controlled by flashing and gutters that is drained to exterior and cannot damage adjacent materials or finishes is not considered water leakage.
- I. Average Thermal Conductance: Provide aluminum-framed systems with fixed glazing and framing areas having average U-factor of not more than 0.69 Btu/sq. ft. x h x deg F (3.92 W/sq. m x K) when tested according to AAMA 1503.
- J. Sound Transmission: Provide aluminum-framed systems with fixed glazing and framing areas having minimum STC 32 according to ASTM E 413 and an OITC 26 according to ASTM E 1332, as determined by testing according to ASTM E 90.

#### 1.4 SUBMITTALS

- A. Product Data: Include construction details, material descriptions, dimensions of individual components and profiles, and finishes for each type of product indicated.
- B. Shop Drawings: For aluminum-framed systems. Include plans, elevations, sections, details, and attachments to other work.
  - 1. Include structural analysis data signed and sealed by the qualified professional engineer responsible for their preparation.
  - 2. Include details of provisions for system expansion and contraction and for draining moisture occurring within the system to the exterior.
  - 3. For entrances, include hardware schedule and indicate operating hardware types, functions, quantities, and locations.
- C. Samples for Verification: For each type of exposed finish required, in manufacturer's standard sizes.
- D. Fabrication Sample: Of each vertical-to-horizontal intersection of systems, made from 12-inch (300-mm) lengths of full-size components and showing details of the following:
  - 1. Joinery.
  - 2. Anchorage.
  - 3. Expansion provisions.
  - 4. Glazing.
  - 5. Flashing and drainage.
- E. Qualification Data: For Installer.
- F. Product Test Reports: Based on evaluation of comprehensive tests performed by a qualified testing agency, for aluminum-framed systems.
- G. Maintenance Data: For aluminum-framed systems to include in maintenance manuals.

#### 1.5 QUALITY ASSURANCE

- A. Installer Qualifications: Capable of assuming engineering responsibility and performing work of this Section and who is acceptable to manufacturer.
  - 1. Engineering Responsibility: Preparation of data for aluminum-framed systems including Shop Drawings based on testing and engineering analysis of manufacturer's standard units in assemblies similar to those indicated for this Project and submission of reports of tests performed on manufacturer's standard assemblies.
- B. Product Options: Information on Drawings and in Specifications establishes requirements for systems' aesthetic effects and performance characteristics. Aesthetic effects are indicated by dimensions, arrangements, alignment, and profiles of components and assemblies as they relate to sightlines, to one another, and to adjoining construction. Performance characteristics are indicated by criteria subject to verification by one or more methods including preconstruction testing, field testing, and in-service performance.
  - 1. Do not modify intended aesthetic effects, as judged solely by Architect, except with Architect's approval. If modifications are proposed, submit comprehensive explanatory data to Architect for review.

- C. Accessible Entrances: Comply with FED-STD-795, "Uniform Federal Accessibility Standards."

## 1.6 PROJECT CONDITIONS

- A. Field Measurements: Verify actual locations of structural supports for aluminum-framed systems by field measurements before fabrication and indicate measurements on Shop Drawings.

## PART 2 - PRODUCTS

### 2.1 MANUFACTURERS

- A. Available Manufacturers: Subject to compliance with requirements, manufacturers offering products that may be incorporated into the Work include, but are not limited to, the following:
  1. Arch Aluminum & Glass Co., Inc.
  2. Kawneer.
  3. YKK
  4. Vistawall Architectural Products.

### 2.2 MATERIALS

- A. Aluminum: Alloy and temper recommended by manufacturer for type of use and finish indicated.
  1. Sheet and Plate: **ASTM B 209 (ASTM B 209M)**.
  2. Extruded Bars, Rods, Profiles, and Tubes: **ASTM B 221 (ASTM B 221M)**.
  3. Extruded Structural Pipe and Tubes: ASTM B 429.
  4. Structural Profiles: ASTM B 308/B 308M.

### 2.3 FRAMING SYSTEMS

- A. Framing Members: Manufacturer's standard extruded-aluminum framing members of thickness required and reinforced as required to support imposed loads.
  1. Construction: Framing members are composite assemblies of two separate extruded-aluminum components permanently bonded by an elastomeric material of low thermal conductance.
- B. Brackets and Reinforcements: Manufacturer's standard high-strength aluminum with nonstaining, nonferrous shims for aligning system components.
- C. Fasteners and Accessories: Manufacturer's standard corrosion-resistant, nonstaining, nonbleeding fasteners and accessories compatible with adjacent materials.
  1. Where fasteners are subject to loosening or turning out from thermal and structural movements, wind loads, or vibration, use self-locking devices.
  2. Reinforce members as required to receive fastener threads.
- D. Concrete and Masonry Inserts: Hot-dip galvanized cast-iron, malleable-iron, or steel inserts complying with ASTM A 123/A 123M or ASTM A 153/A 153M requirements.

- E. Flashing: Manufacturer's standard corrosion-resistant, nonstaining, nonbleeding flashing compatible with adjacent materials. Form exposed flashing from sheet aluminum finished to match framing and of sufficient thickness to maintain a flat appearance without visible deflection.
- F. Framing System Gaskets and Sealants: Manufacturer's standard recommended by manufacturer for joint type.

## 2.4 GLAZING SYSTEMS

- A. Glass: Impact resistant glass complying with the Florida Building Code for missile impact requirements.
- B. Glazing Gaskets: Manufacturer's standard compression types, replaceable, molded or extruded, that maintain uniform pressure and watertight seal.
- C. Spacers and Setting Blocks: Manufacturer's standard elastomeric types.

## 2.5 ACCESSORY MATERIALS

- A. Joint Sealants: For installation at perimeter of aluminum-framed systems, as specified in Division 7 Section "Joint Sealants."
- B. Bituminous Paint: Cold-applied asphalt-mastic paint complying with SSPC-Paint 12 requirements except containing no asbestos, formulated for 30-mil (0.762-mm) thickness per coat.

## 2.6 FABRICATION

- A. Form aluminum shapes before finishing.
- B. Framing Members, General: Fabricate components that, when assembled, have the following characteristics:
  - 1. Profiles that are sharp, straight, and free of defects or deformations.
  - 2. Accurately fitted joints with ends coped or mitered.
  - 3. Means to drain water passing joints, condensation occurring within framing members, and moisture migrating within the system to exterior.
  - 4. Physical and thermal isolation of glazing from framing members.
  - 5. Accommodations for thermal and mechanical movements of glazing and framing to maintain required glazing edge clearances.
  - 6. Provisions for field replacement of glazing from exterior.
  - 7. Fasteners, anchors, and connection devices that are concealed from view to greatest extent possible.
- C. Mechanically Glazed Framing Members: Fabricate for flush glazing (without projecting stops).
- D. After fabrication, clearly mark components to identify their locations in Project according to Shop Drawings.

## 2.7 ALUMINUM FINISHES

- A. General: Comply with NAAMM's "Metal Finishes Manual for Architectural and Metal Products" for recommendations for applying and designating finishes.
- B. Finish designations prefixed by AA comply with the system established by the Aluminum Association for designating aluminum finishes.
  - 1. Class I, Clear Anodic Finish: AA-M12C22A41 (Mechanical Finish: nonspecular as fabricated; Chemical Finish: etched, medium matte; Anodic Coating: Architectural Class I, clear coating 0.018 mm or thicker) complying with AAMA 611.

## PART 3 - EXECUTION

### 3.1 EXAMINATION

- A. Examine areas, with Installer present, for compliance with requirements for installation tolerances and other conditions affecting performance of work.
  - 1. Proceed with installation only after unsatisfactory conditions have been corrected.

### 3.2 INSTALLATION

- A. General:
  - 1. Comply with manufacturer's written instructions.
  - 2. Do not install damaged components.
  - 3. Fit joints to produce hairline joints free of burrs and distortion.
  - 4. Rigidly secure nonmovement joints.
  - 5. Install anchors with separators and isolators to prevent metal corrosion and electrolytic deterioration.
  - 6. Seal joints watertight, unless otherwise indicated.
- B. Metal Protection:
  - 1. Where aluminum will contact dissimilar metals, protect against galvanic action by painting contact surfaces with primer or by applying sealant or tape or installing nonconductive spacers as recommended by manufacturer for this purpose.
  - 2. Where aluminum will contact concrete or masonry, protect against corrosion by painting contact surfaces with bituminous paint.
- C. Install components to drain water passing joints, condensation occurring within framing members, and moisture migrating within the system to exterior.
- D. Set continuous sill members and flashing in full sealant bed as specified in Division 7 Section "Joint Sealants" and to produce weathertight installation.
- E. Install components plumb and true in alignment with established lines and grades, without warp or rack.
- F. Install glazing as specified in Division 8 Section "Glazing."

- G. Install perimeter joint sealants as specified in Division 7 Section "Joint Sealants" and to produce weathertight installation.
- H. Erection Tolerances: Install aluminum-framed systems to comply with the following maximum tolerances:
  - 1. Location and Plane: Limit variation from true location and plane to 1/8 inch in 12 feet (3 mm in 3.7 m); 1/4 inch (6 mm) over total length.
  - 2. Alignment:
    - a. Where surfaces abut in line, limit offset from true alignment to 1/16 inch (1.5 mm).
    - b. Where surfaces meet at corners, limit offset from true alignment to 1/32 inch (0.8 mm).
  - 3. Diagonal Measurements: Limit difference between diagonal measurement to 1/8 inch (3 mm).

END OF SECTION 08411

## **SECTION 08710 - FINISH HARDWARE**

### **PART 1 GENERAL**

#### **1.01 WORK INCLUDED**

- A. The work in this section shall include furnishing of all items of finish hardware as hereinafter specified or obviously necessary to complete the building, except those items that are specifically excluded from this section of the specification.

#### **1.02 RELATED WORK SPECIFIED ELSEWHERE**

- A. 08111 - Steel Doors and Frames

#### **1.03 DESCRIPTION OF WORK**

- A. Furnish labor and material to complete hardware work indicated, as specified herein, or as may be required by actual conditions at building.
- B. Include all necessary screws, bolts, expansion shields, other devices, if necessary, as required for proper hardware application. The hardware supplier shall assume all responsibility for correct quantities.
- C. Hardware shall meet the requirements of Federal, State and Local codes having jurisdiction over this project, notwithstanding any real or apparent conflict therewith in these specifications.
- D. Fire-rated openings:
  - 1. Provide hardware for fire-rated openings in compliance with A.I.A. (NBFU) Pamphlet No. 80, NFPA Standards NO. 101, UBC 702 (1997) and UL10C. This requirement takes precedence over other requirements for such hardware. Provide only hardware that has been tested and listed by UL for the types and sizes of doors required, and complies with the requirements of the door and door frame labels.
  - 2. Where panic exit devices are required on fire-rated doors, provide supplementary marking on door UL label indicating Fire Door to be equipped with fire exit hardware and provide UL label on exit device indicating "Fire Exit Hardware".
- E. Fasteners:
  - 1. Hardware as furnished shall conform to published templates generally prepared for machine screw installation.
  - 2. Furnish each item complete with all screws required for installation. Typically, all exposed screws installation.
  - 3. Insofar as practical, furnished concealed type fasteners for hardware units that have exposed screws shall be furnished with Phillips flat head screws, finished to match adjacent hardware.
  - 4. Door closers and exit devices to be installed with closed head through bolts (sex bolts).
- F. Exterior openings
  - 1. Provide hardware for hurricane openings in compliance with local jurisdiction. This requirement takes precedence over other requirements for such hardware. Provide only hardware that has been tested and listed by local authority for the types and sizes of doors required, and complies with the requirements of the door and door frame. Coordinate Section (08710) Finish Hardware with the Hollow Metal Doors and Frames (08111).

#### **1.04 QUALITY ASSURANCE**

- A. The supplier to be a directly franchised distributor of the products to be furnished and have in their employ an AHC (Architectural Hardware Consultant). This person is to be available for consultation to the architect, owner and the general contractor at reasonable times during the course of work.
- B. The finish hardware supplier shall prepare and submit to the architect six (6) copies of a complete schedule identifying each door and each set number, following the numbering system and not



creating any separate system himself. He shall submit the schedule for review, make corrections as directed and resubmit the corrected schedule for final approval. Approval of schedule will not relieve Contractor of the responsibility for furnishing all necessary hardware, including the responsibility for furnishing correct quantities.

- C. No manufacturing orders shall be placed until detailed schedule has been submitted to the architect and written approval received.
- D. After hardware schedule has been approved, furnish templates required by manufacturing contractors for making proper provisions in their work for accurate fitting, finishing hardware setting. Furnish templates in ample time to facilitate progress of work.
- E. Hardware supplier shall have an office and warehouse facilities to accommodate the materials used on this project. The supplier must be an authorized distributor of the products specified.
- F. The hardware manufactures are to supply both a pre-installation class as well as a post-installation walk-thru. This is to insure proper installation and provide for any adjustments or replacements of hardware as required.

**1.05 DELIVERY, STORAGE, AND HANDLING**

- A. Wrap, protect finishing hardware items for shipment. Deliver to manufacturing contractors hardware items required by them for their application; deliver balance of hardware to job; store in designated location. Each item shall be clearly marked with its intended location.

**1.06 WARRANTY**

- A. The material furnished shall be warranted for one year after installation or longer as the individual manufacturer’s warranty permits.
- B. The manufacturer against failure due to defective materials and workmanship shall warrant overhead door closers in writing for a period of ten (10) years. Commencing on the Date of Final Completion and Acceptance, and in the event of failure, the manufacture is to promptly repair or replace the defective with no additional cost to the Owner.

**PART II PRODUCTS**

**2.01 ACCEPTABLE MANUFACTURERS**

- A. To the greatest extent possible, obtain each kind of hardware from only one manufacturer.
- B. All numbers and symbols used herein have been taken from the current catalogues of the following manufacturers.

<b>PRODUCT</b>	<b>ACCEPTABLE MANUFACTURER</b>	<b>ACCEPTABLE SUBSTITUTE</b>
1) Hinges	Ives	Hager, Stanley, Bommer
2) Locks & Latches	Schlage	Approved Equal
3) Door Closers	LCN	Approved Equal
4) Wall Stops/Floor Stops, Flush bolts	Ives	Burns, Rockwood,
5) Threshold/Weather-strip	Zero	National Guard, Pemko
6) Silencers	Ives	Trimco, Rockwood
7) Key Cabinet	Lund	Key Control

- C. If material manufactured by other than that specified or listed herewith as an equal, is to be bid upon, permission must be requested from the architect seven (7) days prior to bidding. If substitution is allowed, it will be so noted by addendum.

## **2.02 FINISH OF HARDWARE:**

- A. Exterior Hinges to be stainless (630), Locks to be satin chrome (626), Flat Goods to be satin stainless (630) and the Thresholds to be Mill Finish Aluminum.

## **2.03 HINGES AND PIVOTS:**

- A. Exterior butts shall be Stainless Steel. Butts on all out swinging doors shall be furnished with non-removable pins (NRP).
- B. Doors 5' or less in height shall have two (2) butts. Furnish one (1) additional butt for each 2'6" in height or fraction thereof. Dutch door shall have two (2) butts per leaf.

## **2.04 KEYING:**

- A. Equip locks and cylinders with mastered keyed and construction keyed cylinders.
- B. All bittings shall be issued by lock manufacture per owners instructions.
- C. Provide Four (2) each change keys per lock and Six (6) each grand master, master keys, control keys and (10) each construction keys. Key Schedule:
- D. After a keying meeting between representatives of the Owner, Architect, hardware supplier— provide a keying schedule listing the levels of keying as well as an explanation of the key system's function, the key symbols used and the door numbers controlled.
- E. Provide 3 copies of keying schedule for review prepared and detailed in accordance with referenced DHI publication. Include schematic keying diagram and index each key to unique door designations.
- F. Forward bitting list, key cuts and key system schematic directly to owner, by a means as directed by owner.
- G. Key as directed by owner to existing or new key system.

## **2.05 LOCKSETS:**

- A. Locksets shall be Schlage L and ND Series, unless specified otherwise, with Lever designs as scheduled.

## **2.06 CLOSERS:**

- A. Scheduled Manufacturer: LCN 4040XP series and 1461 Series
- B. Requirements:
- C. Provide door closers certified to ANSI/BHMA A156.4 Grade 1 requirements by a BHMA certified independent testing laboratory. Closers shall be ISO 9000 certified. Units shall be stamped with date of manufacture code.
- D. Door closers shall have fully hydraulic, full rack and pinion action with a high strength Cylinder, and shall utilize full complement bearings at shaft. Cylinder body shall be 1-1/2 inch diameter, and double heat-treated pinion shall be 11/16 inch diameter.
- E. Provide hydraulic fluid requiring no seasonal closer adjustment for temperatures ranging from 120 degrees F to -30 degrees F. Fluid shall be fireproof and shall pass the requirements of the UL10C "positive pressure" fire test.
- F. Spring power shall be continuously adjustable over the full range of closer sizes, and allow for reduced opening force as required by accessibility codes and standards. Hydraulic regulation shall be by tamper-proof, non-critical valves. Closers shall have separate adjustment for latch speed, general speed, and backcheck.
- G. Provide closers with a solid forged steel main arms and factory assembled heavy-duty forged forearms for parallel arm closers.
- H. Closers shall not incorporate Pressure Relief Valve (PRV) technology.
- I. Closer cylinders, arms, adapter plates, and metal covers shall have a powder coating finish which has been certified to exceed 100 hours salt spray testing as described in ANSI Standard A156.4 and ASTM B117, or shall have special rust inhibitor (SRI).

- J. Provide special templates, drop plates, mounting brackets, or adapters for arms as required for details, overhead stops, and other door hardware items interfering with closer mounting.
- K. Mount closers on room side of corridor doors, inside of exterior doors, and stair side of stairway doors from corridors. Closers shall not be visible in corridors, lobbies and other public spaces unless approved by Architect.

**2.07 TRIM AND PLATES:**

- A. Kick plates, mop plates, and armor plates, shall be .050 gauge with satin stainless steel (630) finish. Kick plates to be 10” high, mop plates to be 4” high. All plates shall be two (2) inches less full width of a single door. One (1) inch less door width on a pair of doors.
- B. Push plates, pull plates, door pulls, and miscellaneous door trim shall be shown in the hardware schedule.

**2.08 DOOR STOPS:**

- A. Doorstops shall be furnished for all doors to prevent damage to doors or hardware from striking adjacent walls or fixtures. Wall bumpers equal to Ives WS407 Series are preferred, but where not practical furnish floor stops equal to Ives FS436 or FS438 series. Where conditions prohibit the use of either wall or floor type stops, furnish surface mounted overhead stops equal to Glynn Johnson, 450 Series.

**2.09 THRESHOLDS AND WEATHERSTRIP:**

- A. Thresholds and weather-strip shall be as listed in the hardware schedule.

**2.10 DOOR SILENCERS:**

- A. Furnish rubber door silencers equal to Ives SR64 for all new interior hollow metal frames, (2) per pair and (3) per single door frame.

**PART III EXECUTION**

**3.01 INSTALLATION:**

- A. All hardware shall be applied and installed in accordance with the Finish Hardware schedule. Care shall be exercised not to mar or damage adjacent work.
- B. Contractor to provide a secure lock-up for hardware delivered to the project but not yet installed. Control the handling and installation of hardware items that are not immediately replaceable, so that the completion of the work will not be delayed by hardware losses both before and after installation.
- C. No hardware is to be installed until the hardware manufactures have provided a pre-installation class to insure proper installation of the specified products. A post installation inspection by a manufacturer’s representative will be provided to insure proper installation.

**3.02 ADJUSTING AND CLEANING:**

- A. Contractor shall adjust all hardware in strict compliance with manufacturer’s instructions. Prior to turning project to owner, contractor shall clean and make any final adjustments to the finish hardware.

**3.03 PROTECTION:**

- A. Contractor shall protect the hardware, as it is stored on construction site in a covered and dry place.
- B. Contractor shall protect exposed hardware installed on doors during the construction phase.

**3.04 KEY CABINET:**

- A. Set up and index one (1) Key Cabinet that allows room for expansion for 150% of the number of keys for the project.

**3.05 MANUFACTURER INDEX:**

IVE = Ives  
LCN = LCN Closers  
SCH = Schlage  
ZER = Zero  
LDW = Less Door Width  
LAR = Length as Required

**Hardware Group No. 01**

For use on mark/door #(s):

101

Each To Have:

Qty		Description	Catalog Number	Finish	Mfr
3	EA	HINGE	5BB1 4.5 X 4.5 NRP	630	IVE
1	EA	CLOSET LOCK W/DB	L9465P 06A	626	SCH
1	EA	SURFACE CLOSER	4040XP CUSH SRI TBSRT	689	LCN
1	EA	RAIN DRIP	11A	A	ZER
1	EA	GASKETING	139A-S	A	ZER
1	EA	GASKETING	475AA-S	AA	ZER
1	EA	GASKETING	8144SBK PSA	BK	ZER
1	EA	DOOR SWEEP	539AA	AA	ZER
1	EA	THRESHOLD	566A-223	A	ZER

SCHLAGE LOCK CO. NOA #17-0320.06 - WATER INFILTRATION COMPLIANT  
FAS-SEAL DOOR SWEEP BY DOOR SUPPLIER

**Hardware Group No. 01A**

For use on mark/door #(s):

105

106

Each To Have:

Qty		Description	Catalog Number	Finish	Mfr
3	EA	HINGE	5BB1 4.5 X 4.5 NRP	630	IVE
1	EA	CLOSET LOCK W/DB	L9465P 06A	626	SCH
1	EA	SURFACE CLOSER	4040XP REG OR PA AS REQ SRI TBSRT	689	LCN
1	EA	FLOOR STOP/HOLDER	FS446	US26D	IVE
1	EA	RAIN DRIP	11A	A	ZER
1	EA	GASKETING	139A-S	A	ZER
1	EA	GASKETING	475AA-S	AA	ZER
1	EA	GASKETING	8144SBK PSA	BK	ZER
1	EA	DOOR SWEEP	539AA	AA	ZER
1	EA	THRESHOLD	566A-223	A	ZER

SCHLAGE LOCK CO. NOA #17-0320.06 - WATER INFILTRATION COMPLIANT  
FAS-SEAL DOOR SWEEP BY DOOR SUPPLIER

**Hardware Group No. 02**  
 For use on mark/door #(s):

102                      103                      104

Each To Have:

Qty		Description	Catalog Number	Finish	Mfr
3	EA	HINGE	5BB1 4.5 X 4.5 NRP	630	IVE
1	EA	STOREROOM W/DEADBOLT	L9480P 06A	626	SCH
1	EA	SURFACE CLOSER	4040XP CUSH SRI TBSRT	689	LCN
1	EA	RAIN DRIP	11A	A	ZER
1	EA	GASKETING	139A-S	A	ZER
1	EA	GASKETING	475AA-S	AA	ZER
1	EA	GASKETING	8144SBK PSA	BK	ZER
1	EA	DOOR SWEEP	539AA	AA	ZER
1	EA	THRESHOLD	566A-223	A	ZER

SCHLAGE LOCK CO. NOA #17-0320.06 - WATER INFILTRATION COMPLIANT  
 FAS-SEAL DOOR SWEEP BY DOOR SUPPLIER

END OF DOCUMENT 08710

## SECTION 09220 - PORTLAND CEMENT PLASTER

### PART 1 - GENERAL

#### 1.1 RELATED DOCUMENTS

- A. Drawings and general provisions of the Contract, including General and Supplementary Conditions and Division 1 Specification Sections, apply to this Section.

#### 1.2 SUMMARY

- A. This Section includes the following:
  - 1. Exterior portland cement plasterwork (stucco) on solid- plaster bases.
- B. Related Sections include the following:
  - 1. Division 7 Section "Joint Sealants" for sealants installed with exterior portland cement plaster (stucco).

#### 1.3 SUBMITTALS

- A. Product Data: For each type of product indicated.
- B. Samples for Verification: For each type of textured finish coat indicated; 12 by 12 inches (305 by 305 mm), and prepared on rigid backing.

#### 1.4 QUALITY ASSURANCE

- A. Mockups: Before plastering, install mockups of at least 100 sq. ft. (9 sq. m) in surface area to demonstrate aesthetic effects and set quality standards for materials and execution.
  - 1. Install mockups for each type of finish indicated.
  - 2. Approved mockups may become part of the completed Work if undisturbed at time of Substantial Completion.

#### 1.5 DELIVERY, STORAGE, AND HANDLING

- A. Store materials inside under cover and keep them dry and protected against damage from weather, direct sunlight, surface contamination, corrosion, construction traffic, and other causes.

## 1.6 PROJECT CONDITIONS

- A. Comply with ASTM C 926 requirements.
- B. Exterior Plasterwork:
  - 1. Apply and cure plaster to prevent plaster drying out during curing period. Use procedures required by climatic conditions, including moist curing, providing coverings, and providing barriers to deflect sunlight and wind.
  - 2. Apply plaster when ambient temperature is greater than 40 deg F (4.4 deg C).
  - 3. Protect plaster coats from freezing for not less than 48 hours after set of plaster coat has occurred.

## PART 2 - PRODUCTS

### 2.1 MANUFACTURERS

- A. In other Part 2 articles where titles below introduce lists, the following requirements apply to product selection:
  - 1. Available Manufacturers: Subject to compliance with requirements, manufacturers offering products that may be incorporated into the Work include, but are not limited to, manufacturers specified.

### 2.2 METAL LATH

- A. Expanded-Metal Lath: ASTM C 847 with ASTM A 653/A 653M, G60 (Z180), hot-dip galvanized zinc coating.
  - 1. Available Manufacturers:
    - a. Alabama Metal Industries Corporation (AMICO).
    - b. California Expanded Metal Products Company (CEMCO).
    - c. Dale/Incor.
    - d. Marino/Ware; Division of Ware Industries, Inc.
    - e. Phillips Manufacturing Co.
    - f. Unimast, Inc.
    - g. Western Metal Lath & Steel Framing Systems.
  - 2. Diamond-Mesh Lath: Self-furring.
    - a. Weight: 2.5 lb/sq. yd. (1.4 kg/sq. m).
  - 3. Flat Rib Lath: Rib depth of not more than 1/8 inch (3.1 mm).
    - a. Weight: 2.75 lb/sq. yd. (1.5 kg/sq. m).

## 2.3 ACCESSORIES

- A. General: Comply with ASTM C 1063 and coordinate depth of trim and accessories with thicknesses and number of plaster coats required.
- B. Zinc and Zinc-Coated (Galvanized) Accessories:
  - 1. Available Manufacturers:
    - a. Alabama Metal Industries Corporation (AMICO).
    - b. California Expanded Metal Products Company (CEMCO).
    - c. Dale/Incor.
    - d. Dietrich Industries, Inc.
    - e. Phillips Manufacturing Co.
    - f. Unimast, Inc.
    - g. Western Metal Lath & Steel Framing Systems.
    - h. Insert manufacturer's name.
- C. Plastic Trim: Fabricated from high-impact PVC.
  - 1. Available Manufacturers:
    - a. Alabama Metal Industries Corporation (AMICO).
    - b. Plastic Components, Inc.
    - c. Vinyl Corp.
  - 2. Casing Beads: With perforated flanges in depth required to suit plaster bases indicated and flange length required to suit applications indicated.
    - a. Square-edge style; use unless otherwise indicated.
    - b. Bull-nose style, radius **3/4 inch (19.1 mm)** minimum; use at locations indicated on Drawings.
  - 3. Control Joints: One-piece-type, folded pair of unperforated screeds in M-shaped configuration; with perforated flanges and removable protective tape on plaster face of control joint.

## 2.4 MISCELLANEOUS MATERIALS

- A. Water for Mixing: Potable and free of substances capable of affecting plaster set or of damaging plaster, lath, or accessories.
- B. Bonding Compound: ASTM C 932.
- C. Steel Drill Screws: For metal-to-metal fastening, ASTM C 1002 or ASTM C 954, as required by thickness of metal being fastened; with pan head that is suitable for application; in lengths required to achieve penetration through joined materials of not fewer than three exposed threads.
- D. Fasteners for Attaching Metal Lath to Substrates: Complying with ASTM C 1063.



## 2.5 PLASTER MATERIALS

- A. Portland Cement: ASTM C 150, Type I.
  - 1. Color for Finish Coats: Gray.
- B. Lime: ASTM C 206, Type S; or ASTM C 207, Type S.
- C. Sand Aggregate: ASTM C 897.

## 2.6 PLASTER MIXES

- A. General: Comply with ASTM C 926 for applications indicated.
  - 1. Fiber Content: Add fiber to base-coat mixes after ingredients have mixed at least two minutes. Comply with fiber manufacturer's written instructions for fiber quantities in mixes, but do not exceed **1 lb of fiber/cu. ft. (16 kg of fiber/cu. m)** of cementitious materials. Reduce aggregate quantities accordingly to maintain workability.
- B. Base-Coat Mixes for Use over Concrete Unit Masonry: Single base coats for two-coat plasterwork as follows:
  - 1. Portland Cement Mix: For cementitious material, mix 1 part portland cement and 3/4 to 1-1/2 parts lime. Use 2-1/2 to 4 parts aggregate per part of cementitious material (sum of separate volumes of each component material).
- C. Job-Mixed Finish-Coat Mixes:
  - 1. Portland Cement Mix: For cementitious materials, mix 1 part portland cement and 1-1/2 to 2 parts lime. Use 1-1/2 to 3 parts aggregate per part of cementitious material (sum of separate volumes of each component material).

## PART 3 - EXECUTION

### 3.1 EXAMINATION

- A. Examine areas and substrates, with Installer present, and including welded hollow-metal frames, cast-in anchors, and structural framing, for compliance with requirements and other conditions affecting performance.
  - 1. Proceed with installation only after unsatisfactory conditions have been corrected.

### 3.2 PREPARATION

- A. Protect adjacent work from soiling, spattering, moisture deterioration, and other harmful effects caused by plastering.
- B. Prepare solid-plaster bases that are smooth or that do not have the suction capability required to bond with plaster according to ASTM C 926.

### 3.3 INSTALLING METAL LATH

- A. Expanded-Metal Lath: Install according to ASTM C 1063.
  - 1. Flat-Ceiling and Horizontal Framing: Install flat diamond-mesh lath.
  - 2. On Solid Surfaces, Not Otherwise Furred: Install self-furring diamond-mesh lath.

### 3.4 INSTALLING ACCESSORIES

- A. Install according to ASTM C 1063 and at locations indicated on Drawings.
- B. Control Joints: Install control joints at locations indicated on Drawings.
  - 1. As required to delineate plasterwork into areas (panels) of the following maximum sizes:
    - a. Vertical Surfaces: 144 sq. ft. (13.4 sq. m).
    - b. Horizontal and other Nonvertical Surfaces: 100 sq. ft. (9.3 sq. m).
  - 2. At distances between control joints of not greater than 18 feet (5.5 m) o.c.
  - 3. As required to delineate plasterwork into areas (panels) with length-to-width ratios of not greater than 2-1/2:1.
  - 4. Where control joints occur in surface of construction directly behind plaster.
  - 5. Where plasterwork areas change dimensions, to delineate rectangular-shaped areas (panels) and to relieve the stress that occurs at the corner formed by the dimension change.

### 3.5 PLASTER APPLICATION

- A. General: Comply with ASTM C 926.
  - 1. Do not deviate more than plus or minus 1/4 inch in 10 feet (6.4 mm in 3 m) from a true plane in finished plaster surfaces, as measured by a 10-foot (3-m) straightedge placed on surface.
  - 2. Grout hollow-metal frames, bases, and similar work occurring in plastered areas, with base-coat plaster material, before lathing where necessary. Except where full grouting is indicated or required for fire-resistance rating, grout at least 6 inches (152 mm) at each jamb anchor.
  - 3. Finish plaster flush with metal frames and other built-in metal items or accessories that act as a plaster ground, unless otherwise indicated. Where casing bead does not terminate plaster at metal frame, cut base coat free from metal frame before plaster sets and groove finish coat at junctures with metal.
  - 4. Provide plaster surfaces that are ready to receive field-applied finishes indicated.
- B. Bonding Compound: Apply on unit masonry plaster bases.
- C. Plaster Finish Coats: Apply to match stucco finish on existing building.

### 3.6 CUTTING AND PATCHING

- A. Cut, patch, replace, and repair plaster as necessary to accommodate other work and to restore cracks, dents, and imperfections. Repair or replace work to eliminate blisters, buckles, crazing and check cracking, dry outs, efflorescence, sweat outs, and similar defects and where bond to substrate has failed.

3.7 CLEANING AND PROTECTION

- A. Remove temporary protection and enclosure of other work. Promptly remove plaster from doorframes, windows, and other surfaces not indicated to be plastered. Repair floors, walls, and other surfaces stained, marred, or otherwise damaged during plastering.

END OF SECTION 09220

---

SECTION 09671-RESINOUS FLOORING  
**HYBRI-FLEX EQ28**

PART 1 – GENERAL

1.1 RELATED DOCUMENTS

- A. Drawings and general provisions of the Contract, including General and Supplementary Conditions and Division 1 Specification Sections, apply to this Section.

1.2 SUMMARY

- A. This section includes the following:
  - 1. Resinous flooring system including Vapor Mitigation System as shown on the drawings and in schedules. Dur-A-Flex, Inc, Hybri-Flex EQ seamless flooring system is the Basis of Design.
- B. Related sections include the following:
  - 1. Cast-in-Place Concrete on Structural Sheet S-1.

1.3 SYSTEM DESCRIPTION

- A. The work shall consist of preparation of the substrate, the furnishing and application of a cementitious urethane based self-leveling seamless flooring system with decorative quartz aggregate broadcast and Epoxy broadcast and urethane topcoat.
- B. The system shall have the color and texture as specified by the Owner with a nominal thickness of 1/4 inch. It shall be applied to the prepared area(s) as defined in the plans strictly in accordance with the Manufacturer's recommendations.
- C. Cove base (if required) to be applied where noted on plans and per manufacturers standard details unless otherwise noted

1.4 SUBMITTALS

- A. Product Data: Latest edition of Manufacturer's literature including performance data and installation procedures.
- B. Manufacturer's Material Safety Data Sheet (MSDS) for each product being used.
- C. Samples: A 3 inch square sample of the proposed system. Color, texture, and thickness shall be representative of overall appearance of finished system.

1.5 QUALITY ASSURANCE

- A. The Manufacturer shall have a minimum of 5 years experience in the production, sales, and technical support of cementitious urethane, epoxy industrial flooring, quartz aggregate and related materials.
- B. The Applicator shall have been approved by the flooring system manufacturer in all phases of surface preparation and application of the product specified.
- C. No requests for substitutions shall be considered that would change the generic type of the specified System.
- D. System shall be in compliance with requirements of United States Department of Agriculture (USDA), Food, Drug Administration (FDA), and local Health Department.
- D. A pre-installation conference shall be held between Applicator, General Contractor and the Owner to review and clarification of this specification, application procedure, quality control, inspection and acceptance criteria and production schedule.

## 1.6 PRODUCT DELIVERY, STORAGE, AND HANDLING

### A. Packing and Shipping

1. All components of the system shall be delivered to the site in the Manufacturer's packaging, clearly identified with the product type and batch number.

### B. Storage and Protection

1. The Applicator shall be provided with a dry storage area for all components. The area shall be between 60 F and 85 F, dry, out of direct sunlight and in accordance with the Manufacturer's recommendations and relevant health and safety regulations.
2. Copies of Material Safety Data Sheets (MSDS) for all components shall be kept on site for review by the Engineer or other personnel.

### C. Waste Disposal

1. The Applicator shall be provided with adequate disposal facilities for non-hazardous waste generated during installation of the system.

## 1.7 PROJECT CONDITIONS

### A. Site Requirements

1. Application may proceed while air, material and substrate temperatures are between 60 F and 85 F providing the substrate temperature is above the dew point. Outside of this range, the Manufacturer shall be consulted.
2. The relative humidity in the specific location of the application shall be less than 85 % and the surface temperature shall be at least 5 F above the dew point.
3. The Applicator shall ensure that adequate ventilation is available for the work area. This shall include the use of manufacturer's approved fans, smooth bore tubing and closure of the work area.
4. The Applicator shall be supplied with adequate lighting equal to the final lighting level during the preparation and installation of the system.

### B. Conditions of new concrete to be coated with cementitious urethane material.

1. Concrete shall be moisture cured for a minimum of 3 days and have fully cured a minimum of 5 days in accordance with ACI-308 prior to the application of the coating system pending moisture tests.
2. Concrete shall have a flat rubbed finish, float or light steel trowel finish (a hard steel trowel finish is neither necessary nor desirable).
3. Sealers and curing agents should not to be used.
4. Concrete shall have minimum design strength of 3,500 psi. and a maximum water/cement ratio of 0.45
5. Concrete surfaces on grade shall have been constructed with a vapor barrier to protect against the effects of vapor transmission and possible delamination of the system.

### C. Safety Requirements

1. All open flames and spark-producing equipment shall be removed from the work area prior to commencement of application.
2. "No Smoking" signs shall be posted at the entrances to the work area.
3. The Owner shall be responsible for the removal of foodstuffs from the work area.
4. Non-related personnel in the work area shall be kept to a minimum.

## 1.8 WARRANTY

- A. Manufacture warrants that material shipped to buyers at the time of shipment substantially free from material defects and will perform substantially to Manufacture's published literature if used in accordance with the latest prescribed procedures and prior to the expiration date.
- B. Manufacture's liability with respect to this warranty is strictly limited to the value of the material purchase.

## PART 2 – PRODUCTS

### 2.1 FLOORING

- A. Dur-A-Flex, Inc, Hybri-Flex EQ (self leveling broadcast quartz), epoxy/aliphatic urethane topcoat seamless flooring system is the Basis of Design.
  - 1. System Materials:
    - a. Topping: Dur-A-Flex, Inc, Poly-Crete MD resin, hardener and SL aggregate.
    - b. The broadcast aggregate shall be Dur-A-Flex, Inc. Q28 quartz aggregate.
    - c. Broadcast: Dur-A-Flex, Inc. Dur-A-Glaze #4, epoxy based two-component resin.
    - d. Seal Coats: Dur-A-Flex, Inc Dur-A-Glaze #4, epoxy-based, two-component resin.
    - e. Topcoat: Dur-A-Flex, Inc. Armor Top aliphatic urethane resin and hardener.
    - f. Primer: Dur-A-Flex DUR-A-GLAZE MVP PRIMER, a clear 100% solids epoxy moisture mitigation system
  - 2. Patch Materials
    - a. Shallow Fill and Patching: Use Dur-A-Flex, Inc. Poly-Crete MD (up to ¼ inch).
    - b. Deep Fill and Sloping Material (over ¼ inch): Use Dur-A-Flex, Inc. Poly-Crete WR.

### 2.2 MANUFACTURER

- A. Dur-A-Flex, Inc., 95 Goodwin Street, East Hartford, CT 06108, Phone: (860) 528-9838, Fax: (860) 528-2802
- B. Manufacturer of Approved System shall be single source and made in the USA.

### 2.3 PRODUCT REQUIREMENTS

A. Topping	Poly-Crete SL
1. Percent Reactive	100 %
2. VOC	0 g/L
3. Bond Strength to Concrete ASTM D 4541	400 psi, substrates fails
4. Compressive Strength, ASTM C579	7,250 psi
5. Tensile Strength, ASTM D 638	750 psi
6. Flexural Strength, ASTM D 790	4,400 psi
7. Impact Resistance @ 125 mils, MIL D-3134, No visible damage or deterioration	160 inch lbs
B. Broadcast Coat	Dur-A-Glaze #4 Resin
1. Percent Reactive,	100 %
2. VOC	<4 g/L
3. Water Absorption, ASTM D 570	0.04%
4. Tensile Strength, ASTM D 638	4000psi
5. Coefficient of thermal expansion ASTM D 696,	2 x 10 <sup>-5</sup> in/in/F
6. Flammability ASTM D-635	Self-Extinguishing
7. Flame Spread/ NFPA 101 ASTM E-84	Class A
C. Topcoat	Armor Top
1. VOC	0 g/L
2. 60 Degree Gloss ASTM D523	75+/-5

3. Mixed Viscosity, (Brookfield 25°C)	500 cps
4. Tensile strength, ASTM D 638	7,000 psi
5. Abrasion Resistance, ASTM D4060	Gloss Satin
CS 17 wheel (1,000 g load) 1,000 cycles	4 8 mg loss with grit
	10 12 mg loss without grit
6. Pot life @ 70° F 50% RH	2 hours
7. Full Chemical resistance	7 days

C. Primer

DUR-A-GLAZE MVP PRIMER

1. Resin type	Epoxy
2. Color	Clear
3. % Solids	100%
4. Mix Ratio (by volume)	2 resin to 1 hardener
5. Viscosity at 70°F (mixed hardener & resin)	1,400 cps
6. Pot Life at 70°F	45 minutes
7. Recoat range at 70°F	12 – 24 hours
8. Foot traffic	24 hours
9. Cured Film Thickness	16 mils at 100 sq. ft. per gallon
10. Shelf life	1 year when stored in original packaging at 73° F
11. VOC	0 g/L

PART 3 – EXECUTION

3.1 EXAMINATION

- A. Examine substrates, areas and conditions, with Applicator present, for compliance with requirements for maximum moisture content, installation tolerances and other conditions affecting flooring performance.
1. Verify that substrates and conditions are satisfactory for flooring installation and comply with requirements specified.

3.2 PREPARATION

A. General

1. New and existing concrete surfaces shall be free of oil, grease, curing compounds, loose particles, moss, algae growth, laitance, friable matter, dirt, and bituminous products.
2. Moisture Testing: Perform tests recommended by manufacturer and as follows.
  - a. Perform anhydrous calcium chloride test ASTM F 1869-98. Application will proceed only when the vapor/moisture emission rates from the slab is less than and not higher than 12 lbs/1,000 sf/24 hrs.
  - b. Perform relative humidity test using is situ probes, ASTM F 2170. Proceed with installation only after substrates have a maximum 92% relative humidity level measurement.
  - c. If the vapor drive exceeds 92% relative humidity or 12 lbs/1,000 sf/24 hrs then the Owner and/or Engineer shall be notified and advised of additional cost for the possible installation of a vapor mitigation system that has been approved by the manufacturer or other means to lower the value to the acceptable limit.
3. Mechanical surface preparation
  - a. Shot blast all surfaces to receive flooring system with a mobile steel shot, dust recycling machine (Blastrac or equal). All surface and embedded accumulations of paint, toppings hardened concrete layers, laitance, power trowel finishes and other similar surface characteristics shall be completely removed leaving a bare concrete surface having a minimum profile of CSP 4-5 as described by the International Concrete Repair Institute.
  - b. Floor areas inaccessible to the mobile blast machines shall be mechanically abraded to the same degree of cleanliness, soundness and profile using diamond grinders, needle guns, bush hammers, or other suitable equipment.
  - c. Where the perimeter of the substrate to be coated is not adjacent to a wall or curb, a minimum 1/4 inch

key cut shall be made to properly seat the system, providing a smooth transition between areas. The detail cut shall also apply to drain perimeters and expansion joint edges.

- d. Cracks and joints (non-moving) greater than 1/8 inch wide are to be chiseled or chipped-out and repaired per manufacturer's recommendations.
  - e. For Moisture Mitigation System refer to manufactures Surface Preparation Guide.
4. At spalled or worn areas, mechanically remove loose or delaminated concrete to a sound concrete and patch per manufactures recommendations.

### 3.3 APPLICATION

#### A. General

1. The system shall be applied in five distinct steps as listed below:
  - a. Substrate preparation
  - b. Vapor mitigation system application
  - c. Topping/overlay application with quartz aggregate broadcast.
  - d. Resin application with quartz aggregate broadcast.
  - e. Topcoat application
  - f. Second topcoat application.
2. Immediately prior to the application of any component of the system, the surface shall be dry and any remaining dust or loose particles shall be removed using a vacuum or clean, dry, oil-free compressed air.
3. The handling, mixing and addition of components shall be performed in a safe manner to achieve the desired results in accordance with the Manufacturer's recommendations.
4. The system shall follow the contour of the substrate unless pitching or other leveling work has been specified by the Architect.
5. A neat finish with well-defined boundaries and straight edges shall be provided by the Applicator.

#### B. Moisture Mitigation System

1. Pour 2 parts resin into 1 part hardener and mix for 2 minutes using a jiffler-type mixer at 300 – 450 rpm. DUR-A-GLAZE MVP PRIMER is applied with a 3/16 inch V-notched squeegee and back-rolled with a 3/8 inch nap roller cover. Apply at a rate of 100 sq.ft./gallon to yield a dry film thickness of 16 mils.

#### C. Topping

1. The topping shall be applied as a self-leveling system as specified by the Architect. The topping shall be applied in one lift with a nominal thickness of 1/8 inch.
2. The topping shall be comprised of three components, a resin, hardener and filler as supplied by the Manufacturer.
3. The hardener shall be added to the resin and thoroughly dispersed by suitably approved mechanical means. SL Aggregate shall then be added to the catalyzed mixture and mixed in a manner to achieve a homogenous blend.
4. The topping shall be applied over horizontal surfaces using ½ inch “v” notched squeegee, trowels or other systems approved by the Manufacturer.
5. Immediately upon placing, the topping shall be degassed with a loop roller.
6. Quartz aggregate shall be broadcast to excess into the wet material at the rate of 0.8 lbs/sf.
7. Allow material to fully cure. Vacuum, sweep and/or blow to remove all loose aggregate.

#### D. Broadcast

1. The broadcast coat resin shall be applied at the rate of 90 sf/gal.



2. The broadcast coat shall be comprised of liquid components, combined at a ratio of 2 parts resin to 1 part hardener by volume and shall be thoroughly blended by mechanical means such as a high speed paddle mixer.
3. Quartz aggregate shall be broadcast into the wet resin at the rate of 0.5 lbs/sf.
4. Allow material to fully cure. Vacuum, sweep and/or blow to remove all loose aggregate.

E. Topcoat

1. The first topcoat shall be squeegee applied with a coverage rate of 90 sf/gal.
2. The topcoat shall be comprised of liquid components, combined at a ratio of 2 parts resin to 1 part hardener by volume and shall be thoroughly blended by mechanical means such as a high speed paddle mixer.
3. The first topcoat will be back rolled and cross rolled to provide a uniform texture and finish
2. The second topcoat (Armor Top) shall be roller applied with a coverage rate of 500 sf/gal.
3. The finish floor will have a nominal thickness of 1/4 inch.

3.4 FIELD QUALITY CONTROL

A. Tests, Inspection

1. The following tests shall be conducted by the Applicator:
  - a. Temperature
    1. Air, substrate temperatures and, if applicable, dew point.
  - b. Coverage Rates
    1. Rates for all layers shall be monitored by checking quantity of material used against the area covered.

3.5 CLEANING AND PROTECTION

- A. Cure flooring material in compliance with manufacturer's directions, taking care to prevent their contamination during stages of application and prior to completion of the curing process.
- B. Remove masking. Perform detail cleaning at floor termination, to leave cleanable surface for subsequent work of other sections.

END OF SECTION 09671

## SECTION 09911 - EXTERIOR PAINTING

### PART 1 - GENERAL

#### 1.1 RELATED DOCUMENTS

- A. Drawings and general provisions of the Contract, including General and Supplementary Conditions and Division 1 Specification Sections, apply to this Section.

#### 1.2 SUMMARY

- A. This Section includes surface preparation and the application of paint systems on the following exterior substrates:
  - 1. Exterior portland cement plaster(stucco).
  - 2. Fiber-Cement Soffit and Battens.
  - 3. Fiber-Cement Fascia and Trim.
- B. Related Sections include the following:
  - 1. Division 9 Section "Interior Painting" for surface preparation and the application of paint systems on interior substrates.

#### 1.3 SUBMITTALS

- A. Product Data: For each type of product indicated.
- B. Samples for Initial Selection: For each type of topcoat product indicated.
- C. Samples for Verification: For each type of paint system and each color and gloss of topcoat indicated.
  - 1. Submit Samples on rigid backing, 8 inches (200 mm) square.
  - 2. Step coats on Samples to show each coat required for system.
  - 3. Label each coat of each Sample.
  - 4. Label each Sample for location and application area.
- D. Product List: For each product indicated, include the following:
  - 1. Cross-reference to paint system and locations of application areas. Use same designations indicated on Drawings and in schedules.
  - 2. Printout of current "MPI Approved Products List" for each product category specified in Part 2, with the proposed product highlighted.

#### 1.4 QUALITY ASSURANCE

##### A. MPI Standards:

1. Products: Complying with MPI standards indicated and listed in "MPI Approved Products List."
2. Preparation and Workmanship: Comply with requirements in "MPI Architectural Painting Specification Manual" for products and paint systems indicated.

##### B. Mockups: Apply benchmark samples of each paint system indicated and each color and finish selected to verify preliminary selections made under sample submittals and to demonstrate aesthetic effects and set quality standards for materials and execution.

1. Architect will select one surface to represent surfaces and conditions for application of each paint system specified in Part 3.
  - a. Vertical and Horizontal Surfaces: Provide samples of at least 100 sq. ft. (9 sq. m).
  - b. Other Items: Architect will designate items or areas required.
2. Final approval of color selections will be based on benchmark samples.
  - a. If preliminary color selections are not approved, apply additional benchmark samples of additional colors selected by Architect at no added cost to Owner.

#### 1.5 DELIVERY, STORAGE, AND HANDLING

##### A. Store materials not in use in tightly covered containers in well-ventilated areas with ambient temperatures continuously maintained at not less than 45 deg F (7 deg C).

1. Maintain containers in clean condition, free of foreign materials and residue.
2. Remove rags and waste from storage areas daily.

#### 1.6 PROJECT CONDITIONS

##### A. Apply paints only when temperature of surfaces to be painted and ambient air temperatures are between 50 and 95 deg F (10 and 35 deg C).

##### B. Do not apply paints in snow, rain, fog, or mist; when relative humidity exceeds 85 percent; at temperatures less than 5 deg F (3 deg C) above the dew point; or to damp or wet surfaces.

#### 1.7 EXTRA MATERIALS

##### A. Furnish extra materials described below that are from same production run (batch mix) as materials applied and that are packaged for storage and identified with labels describing contents.

1. Quantity: Furnish an additional 5 Insert number percent, but not less than 1 gal. (3.8 L) of each material and color applied.

## PART 2 - PRODUCTS

### 2.1 MANUFACTURERS

- A. Available Manufacturers: Subject to compliance with requirements, manufacturers offering products that may be incorporated into the Work include, but are not limited to, the following:
  - 1. Benjamin Moore & Co.
  - 2. ICI Paints
  - 3. PPG Architectural Finishes, Inc.
  - 4. Sherwin-Williams Company .

### 2.2 PAINT, GENERAL

- A. Material Compatibility:
  - 1. Provide materials for use within each paint system that are compatible with one another and substrates indicated, under conditions of service and application as demonstrated by manufacturer, based on testing and field experience.
- B. VOC Content: Provide materials that comply with VOC limits of authorities having jurisdiction.
- C. Colors: As selected by Architect from manufacturer's full range.

### 2.3 PRIMERS/SEALERS

- A. Alkali-Resistant Primer: MPI #3.
  - 1. VOC Content: E Range of E1.

### 2.4 EXTERIOR LATEX PAINTS

- A. Exterior Latex (Flat): MPI #10 (Gloss Level 1).
  - 1. VOC Content: E Range of E1.
- B. Exterior Latex (Semigloss): MPI #11 (Gloss Level 5).
  - 1. VOC Content: E Range of E1.
- C. Exterior Latex (Gloss): MPI #119 (Gloss Level 6, except minimum gloss of 65 units at 60 deg).
  - 1. VOC Content: E Range of E1.

## PART 3 - EXECUTION

### 3.1 EXAMINATION

- A. Examine substrates and conditions, with Applicator present, for compliance with requirements for maximum moisture content and other conditions affecting performance of work.
- B. Maximum Moisture Content of Substrates: When measured with an electronic moisture meter as follows:
  - 1. Plaster: 12 percent.
- C. Verify suitability of substrates, including surface conditions and compatibility with existing finishes and primers.
- D. Begin coating application only after unsatisfactory conditions have been corrected and surfaces are dry.
  - 1. Beginning coating application constitutes Contractor's acceptance of substrates and conditions.

### 3.2 PREPARATION

- A. Comply with manufacturer's written instructions and recommendations in "MPI Architectural Painting Specification Manual" applicable to substrates and paint systems indicated.
- B. Remove plates, machined surfaces, and similar items already in place that are not to be painted. If removal is impractical or impossible because of size or weight of item, provide surface-applied protection before surface preparation and painting.
  - 1. After completing painting operations, use workers skilled in the trades involved to reinstall items that were removed. Remove surface-applied protection if any.
  - 2. Do not paint over labels of independent testing agencies or equipment name, identification, performance rating, or nomenclature plates.
- C. Clean substrates of substances that could impair bond of paints, including dirt, oil, grease, and incompatible paints and encapsulants.
  - 1. Remove incompatible primers and reprime substrate with compatible primers as required to produce paint systems indicated.
- D. Concrete Masonry Substrates: Remove efflorescence and chalk. Do not paint surfaces if moisture content or alkalinity of surfaces to be painted exceeds that permitted in manufacturer's written instructions.
- E. Plaster Substrates: Do not begin paint application until plaster is fully cured and dry.

### 3.3 APPLICATION

- A. Apply paints according to manufacturer's written instructions.
  - 1. Use applicators and techniques suited for paint and substrate indicated.
  - 2. Paint surfaces behind movable items same as similar exposed surfaces. Before final installation, paint surfaces behind permanently fixed items with prime coat only.

- B. Tint each undercoat a lighter shade to facilitate identification of each coat if multiple coats of same material are to be applied. Tint undercoats to match color of topcoat, but provide sufficient difference in shade of undercoats to distinguish each separate coat.
- C. If undercoats or other conditions show through topcoat, apply additional coats until cured film has a uniform paint finish, color, and appearance.
- D. Apply paints to produce surface films without cloudiness, spotting, holidays, laps, brush marks, roller tracking, runs, sags, ropiness, or other surface imperfections. Cut in sharp lines and color breaks.

### 3.4 FIELD QUALITY CONTROL

- A. Testing of Paint Materials: Owner reserves the right to invoke the following procedure at any time and as often as Owner deems necessary during the period when paints are being applied:
  - 1. Owner will engage the services of a qualified testing agency to sample paint materials being used. Samples of material delivered to Project site will be taken, identified, sealed, and certified in presence of Contractor.
  - 2. Testing agency will perform tests for compliance of paint materials with product requirements.
  - 3. Owner may direct Contractor to stop applying paints if test results show materials being used do not comply with product requirements. Contractor shall remove noncomplying-paint materials from Project site, pay for testing, and repaint surfaces painted with rejected materials. Contractor will be required to remove rejected materials from previously painted surfaces if, on repainting with complying materials, the two paints are incompatible.

### 3.5 CLEANING AND PROTECTION

- A. At end of each workday, remove rubbish, empty cans, rags, and other discarded materials from Project site.
- B. After completing paint application, clean spattered surfaces. Remove spattered paints by washing, scraping, or other methods. Do not scratch or damage adjacent finished surfaces.
- C. Protect work of other trades against damage from paint application. Correct damage to work of other trades by cleaning, repairing, replacing, and refinishing, as approved by Architect, and leave in an undamaged condition.
- D. At completion of construction activities of other trades, touch up and restore damaged or defaced painted surfaces.

### 3.6 EXTERIOR PAINTING SCHEDULE

- A. Stucco Substrates:
  - 1. Latex Over Alkali-Resistant Primer System: MPI EXT 9.1J.
    - a. Prime Coat: Alkali-resistant primer.
    - b. Intermediate Coat: Exterior latex matching topcoat.
    - c. Topcoat: Exterior latex.(eggshell or satin)

B. Fiber-Cement Fascia, Trim and Soffit:

1. Latex System: MPI EXT 3.3J.

- a. Prime Coat: Alkali-Resistant Primer as recommended in writing by topcoat manufacturer.
- b. Intermediate Coat: As recommended in writing by topcoat manufacturer.
- c. Topcoat: Latex (exterior).

END OF SECTION 09911

## SECTION 09912 - INTERIOR PAINTING

### PART 1 - GENERAL

#### 1.1 RELATED DOCUMENTS

- A. Drawings and general provisions of the Contract, including General and Supplementary Conditions and Division 1 Specification Sections, apply to this Section.

#### 1.2 SUMMARY

- A. This Section includes surface preparation and the application of paint systems on the following interior substrates:
  - 1. Concrete masonry units (CMU).
  - 2. Gypsum board.
- B. Related Sections include the following:
  - 1. Division 9 Section "Exterior Painting" for surface preparation and the application of paint systems on exterior substrates.

#### 1.3 SUBMITTALS

- A. Product Data: For each type of product indicated.
- B. Samples for Initial Selection: For each type of topcoat product indicated.
- C. Samples for Verification: For each type of paint system and in each color and gloss of topcoat indicated.
  - 1. Submit Samples on rigid backing, 8 inches (200 mm) square.
  - 2. Step coats on Samples to show each coat required for system.
  - 3. Label each coat of each Sample.
  - 4. Label each Sample for location and application area.
- D. Product List: For each product indicated, include the following:
  - 1. Cross-reference to paint system and locations of application areas. Use same designations indicated on Drawings and in schedules.
  - 2. Printout of current "MPI Approved Products List" for each product category specified in Part 2, with the proposed product highlighted.

#### 1.4 QUALITY ASSURANCE

- A. MPI Standards:
  - 1. Products: Complying with MPI standards indicated and listed in "MPI Approved Products List."
  - 2. Preparation and Workmanship: Comply with requirements in "MPI Architectural Painting Specification Manual" for products and paint systems indicated.



- B. Mockups: Apply benchmark samples of each paint system indicated and each color and finish selected to verify preliminary selections made under sample submittals and to demonstrate aesthetic effects and set quality standards for materials and execution.
1. Architect will select one surface to represent surfaces and conditions for application of each paint system specified in Part 3.
    - a. Wall and Ceiling Surfaces: Provide samples of at least 100 sq. ft. (9 sq. m).
    - b. Other Items: Architect will designate items or areas required.
  2. Apply benchmark samples after permanent lighting and other environmental services have been activated.
  3. Final approval of color selections will be based on benchmark samples.
    - a. If preliminary color selections are not approved, apply additional benchmark samples of additional colors selected by Architect at no added cost to Owner.

#### 1.5 DELIVERY, STORAGE, AND HANDLING

- A. Store materials not in use in tightly covered containers in well-ventilated areas with ambient temperatures continuously maintained at not less than 45 deg F (7 deg C).
1. Maintain containers in clean condition, free of foreign materials and residue.
  2. Remove rags and waste from storage areas daily.

#### 1.6 PROJECT CONDITIONS

- A. Apply paints only when temperature of surfaces to be painted and ambient air temperatures are between 50 and 95 deg F (10 and 35 deg C).
- B. Do not apply paints when relative humidity exceeds 85 percent; at temperatures less than 5 deg F (3 deg C) above the dew point; or to damp or wet surfaces.

#### 1.7 EXTRA MATERIALS

- A. Furnish extra materials described below that are from same production run (batch mix) as materials applied and that are packaged for storage and identified with labels describing contents.
1. Quantity: Furnish an additional 5 percent, but not less than 1 gal. (3.8 L) of each material and color applied.

### PART 2 - PRODUCTS

#### 2.1 MANUFACTURERS

- A. Available Manufacturers: Subject to compliance with requirements, manufacturers offering products that may be incorporated into the Work include, but are not limited to, the following:
1. Benjamin Moore & Co.
  2. ICI Paints

3. PPG Architectural Finishes, Inc.
4. Sherwin-Williams Company .

## 2.2 ACTION SUBMITTALS

- A. Product Data: For each type of product. Include preparation requirements and application instructions.
- B. Samples for Initial Selection: For each type of topcoat product.
- C. Samples for Verification: For each type of paint system and in each color and gloss of topcoat.
  1. Submit Samples on rigid backing, 8 inches (200 mm) square.
  2. Step coats on Samples to show each coat required for system.
  3. Label each coat of each Sample.
  4. Label each Sample for location and application area.
- D. Product List: For each product indicated, include the following:
  1. Cross-reference to paint system and locations of application areas. Use same designations indicated on Drawings and in schedules.

## 2.3 PAINT, GENERAL

- A. Material Compatibility:
  1. Provide materials for use within each paint system that are compatible with one another and substrates indicated, under conditions of service and application as demonstrated by manufacturer, based on testing and field experience.
  2. For each coat in a paint system, provide products recommended in writing by manufacturers of topcoat for use in paint system and on substrate indicated.
- B. Chemical Components of Field-Applied Interior Paints and Coatings: Provide products that comply with the following limits for VOC content, exclusive of colorants added to a tint base, when calculated according to 40 CFR 59, Subpart D (EPA Method 24) and the following chemical restrictions; these requirements do not apply to primers or finishes that are applied in a fabrication or finishing shop:
  1. Flat Paints and Coatings: VOC content of not more than 50 g/L.
  2. Nonflat Paints and Coatings: VOC content of not more than 150 g/L.
  3. Aromatic Compounds: Paints and coatings shall not contain more than 1.0 percent by weight of total aromatic compounds (hydrocarbon compounds containing one or more benzene rings).
  4. Restricted Components: Paints and coatings shall not contain any of the following:
    - a. Acrolein.
    - b. Acrylonitrile.
    - c. Antimony.
    - d. Benzene.
    - e. Butyl benzyl phthalate.
    - f. Cadmium.
    - g. Di (2-ethylhexyl) phthalate.
    - h. Di-n-butyl phthalate.
    - i. Di-n-octyl phthalate.

- j. 1,2-dichlorobenzene.
- k. Diethyl phthalate.
- l. Dimethyl phthalate.
- m. Ethylbenzene.
- n. Formaldehyde.
- o. Hexavalent chromium.
- p. Isophorone.
- q. Lead.
- r. Mercury.
- s. Methyl ethyl ketone.
- t. Methyl isobutyl ketone.
- u. Methylene chloride.
- v. Naphthalene.
- w. Toluene (methylbenzene).
- x. 1,1,1-trichloroethane.
- y. Vinyl chloride.

C. Colors: As selected by Architect from manufacturer's full range.

#### 2.4 BLOCK FILLERS

- A. Interior/Exterior Latex Block Filler: MPI #4.
  - 1. VOC Content: E Range of E2.

#### 2.5 PRIMERS/SEALERS

- A. Interior Latex Primer/Sealer: MPI #50.
  - 1. VOC Content: E Range of E1.
  - 2. Environmental Performance Rating: EPR 1.

#### 2.6 LATEX PAINTS

- A. High-Performance Architectural Latex (Low Sheen): MPI #138 (Gloss Level 2).
  - 1. VOC Content: E Range of E1.
  - 2. Environmental Performance Rating: EPR 4.
- B. High-Performance Architectural Latex (Eggshell): MPI #139 (Gloss Level 3).
  - 1. VOC Content: E Range of E2.
  - 2. Environmental Performance Rating: EPR 5.
- C. High-Performance Architectural Latex (Satin): MPI #140 (Gloss Level 4).
  - 1. VOC Content: E Range of E1.
  - 2. Environmental Performance Rating: EPR 4.5.
- D. High-Performance Architectural Latex (Semigloss): MPI #141 (Gloss Level 5).
  - 1. VOC Content: E Range of E1.
  - 2. Environmental Performance Rating: EPR 5.

## 2.7 METAL PRIMERS

- A. Alkyd Anticorrosive Metal Primer: MPI #79.
  - 1. VOC Content: E Range of E1.
- B. Quick-Drying Alkyd Metal Primer: MPI #76.
  - 1. VOC Content: E Range of E1.
- C. Cementitious Galvanized-Metal Primer: MPI #26.
  - 1. VOC Content: E Range of E1.

## 2.8 LATEX PAINTS

- A. Interior Latex (Flat): MPI #53 (Gloss Level 1).
  - 1. VOC Content: E Range of E1.
  - 2. Environmental Performance Rating: EPR 1.5.
- B. Interior Latex (Low Sheen): MPI #44 (Gloss Level 2).
  - 1. VOC Content: E Range of E1.
  - 2. Environmental Performance Rating: EPR 1.
- C. Interior Latex (Eggshell): MPI #52 (Gloss Level 3).
  - 1. VOC Content: E Range of E1.
  - 2. Environmental Performance Rating: EPR 1.
- D. Interior Latex (Satin): MPI #43 (Gloss Level 4).
  - 1. VOC Content: E Range of E1.
  - 2. Environmental Performance Rating: EPR 1.5.
- E. Interior Latex (Semigloss): MPI #54 (Gloss Level 5).
  - 1. VOC Content: E Range of E1.
  - 2. Environmental Performance Rating: EPR 2.
- F. Interior Latex (Gloss): MPI #114 (Gloss Level 6, except minimum gloss of 65 units at 60 deg).
  - 1. VOC Content: E Range of E1.
  - 2. Environmental Performance Rating: EPR 2.

## 2.9 ALKYD PAINTS

- A. Interior Alkyd (Flat): MPI #49 (Gloss Level 1).
  - 1. VOC Content: E Range of E1.
- B. Interior Alkyd (Eggshell): MPI #51 (Gloss Level 3).
  - 1. VOC Content: E Range of E1.
- C. Interior Alkyd (Semigloss): MPI #47 (Gloss Level 5).
  - 1. VOC Content: E Range of E1.
  - 2. Environmental Performance Rating: EPR 1.
- D. Interior Alkyd (Gloss): MPI #48 (Gloss Level 6).
  - 1. VOC Content: E Range of E1.
  - 2.

- E. Interior Latex (Semigloss): MPI #54 (Gloss Level 5).
  - 1. VOC Content: E Range of E1.
  - 2. Environmental Performance Rating: EPR 2.
  
- F. Interior Latex (Gloss): MPI #114 (Gloss Level 6, except minimum gloss of 65 units at 60 deg).
  - 1. VOC Content: E Range of E1.
  - 2. Environmental Performance Rating: EPR 2.
  - 3. VOC Content: E Range of E1.

## PART 3 - EXECUTION

### 3.1 EXAMINATION

- A. Examine substrates and conditions, with Applicator present, for compliance with requirements for maximum moisture content and other conditions affecting performance of work.
  
- B. Maximum Moisture Content of Substrates: When measured with an electronic moisture meter as follows:
  - 1. Concrete: 12 percent.
  - 2. Masonry (Clay and CMU): 12 percent.
  - 3. Gypsum Board: 12 percent.
  - 4. Plaster: 12 percent.
  
- C. Verify suitability of substrates, including surface conditions and compatibility with existing finishes and primers.
  
- D. Begin coating application only after unsatisfactory conditions have been corrected and surfaces are dry.
  - 1. Beginning coating application constitutes Contractor's acceptance of substrates and conditions.

### 3.2 PREPARATION

- A. Comply with manufacturer's written instructions and recommendations in "MPI Architectural Painting Specification Manual" applicable to substrates indicated.
  
- B. Remove plates, machined surfaces, and similar items already in place that are not to be painted. If removal is impractical or impossible because of size or weight of item, provide surface-applied protection before surface preparation and painting.
  - 1. After completing painting operations, use workers skilled in the trades involved to reinstall items that were removed. Remove surface-applied protection if any.
  - 2. Do not paint over labels of independent testing agencies or equipment name, identification, performance rating, or nomenclature plates.
  
- C. Clean substrates of substances that could impair bond of paints, including dirt, oil, grease, and incompatible paints and encapsulants.
  - 1. Remove incompatible primers and reprime substrate with compatible primers as required to produce paint systems indicated.

- D. Concrete Substrates: Remove release agents, curing compounds, efflorescence, and chalk. Do not paint surfaces if moisture content or alkalinity of surfaces to be painted exceeds that permitted in manufacturer's written instructions.
- E. Concrete Masonry Substrates: Remove efflorescence and chalk. Do not paint surfaces if moisture content or alkalinity of surfaces to be painted exceeds that permitted in manufacturer's written instructions.
- F. Steel Substrates: Remove rust and loose mill scale. Clean using methods recommended in writing by paint manufacturer.
- G. Galvanized-Metal Substrates: Remove grease and oil residue from galvanized sheet metal fabricated from coil stock by mechanical methods to produce clean, lightly etched surfaces that promote adhesion of subsequently applied paints.
- H. Aluminum Substrates: Remove surface oxidation.
- I. Gypsum Board Substrates: Do not begin paint application until finishing compound is dry and sanded smooth.
- J. Plaster Substrates: Do not begin paint application until plaster is fully cured and dry.

### 3.3 APPLICATION

- A. Apply paints according to manufacturer's written instructions.
  - 1. Use applicators and techniques suited for paint and substrate indicated.
  - 2. Paint surfaces behind movable equipment and furniture same as similar exposed surfaces. Before final installation, paint surfaces behind permanently fixed equipment or furniture with prime coat only.
  - 3. Paint front and backsides of access panels, removable or hinged covers, and similar hinged items to match exposed surfaces.
- B. Tint each undercoat a lighter shade to facilitate identification of each coat if multiple coats of same material are to be applied. Tint undercoats to match color of topcoat, but provide sufficient difference in shade of undercoats to distinguish each separate coat.
- C. If undercoats or other conditions show through topcoat, apply additional coats until cured film has a uniform paint finish, color, and appearance.
- D. Apply paints to produce surface films without cloudiness, spotting, holidays, laps, brush marks, roller tracking, runs, sags, ropiness, or other surface imperfections. Cut in sharp lines and color breaks.
- E. Painting Mechanical and Electrical Work: Paint items exposed in equipment rooms and occupied spaces including, but not limited to, the following:
  - 1. Mechanical Work:
    - a. Uninsulated metal piping.
    - b. Uninsulated plastic piping.
    - c. Pipe hangers and supports.
    - d. Tanks that do not have factory-applied final finishes.
    - e. Visible portions of internal surfaces of metal ducts, without liner, behind air inlets and outlets.

- f. Duct, equipment, and pipe insulation having cotton or canvas insulation covering or other paintable jacket material.
  - g. Mechanical equipment that is indicated to have a factory-primed finish for field painting.
2. Electrical Work:
- a. Switchgear.
  - b. Panelboards.
  - c. Electrical equipment that is indicated to have a factory-primed finish for field painting.

### 3.4 FIELD QUALITY CONTROL

- A. Testing of Paint Materials: Owner reserves the right to invoke the following procedure at any time and as often as Owner deems necessary during the period when paints are being applied:
- 1. Owner will engage the services of a qualified testing agency to sample paint materials being used. Samples of material delivered to Project site will be taken, identified, sealed, and certified in presence of Contractor.
  - 2. Testing agency will perform tests for compliance with product requirements.
  - 3. Owner may direct Contractor to stop applying paints if test results show materials being used do not comply with product requirements. Contractor shall remove noncomplying-paint materials from Project site, pay for testing, and repaint surfaces painted with rejected materials. Contractor will be required to remove rejected materials from previously painted surfaces if, on repainting with complying materials, the two paints are incompatible.

### 3.5 CLEANING AND PROTECTION

- A. At end of each workday, remove rubbish, empty cans, rags, and other discarded materials from Project site.
- B. After completing paint application, clean spattered surfaces. Remove spattered paints by washing, scraping, or other methods. Do not scratch or damage adjacent finished surfaces.
- C. Protect work of other trades against damage from paint application. Correct damage to work of other trades by cleaning, repairing, replacing, and refinishing, as approved by Architect, and leave in an undamaged condition.
- D. At completion of construction activities of other trades, touch up and restore damaged or defaced painted surfaces.

### 3.6 INTERIOR PAINTING SCHEDULE

- A. CMU Substrates:
- 1. Alkyd Over Acrylic Sealer System: MPI INT 4.2N.
    - a. Prime Coat: Interior/exterior Acrylic block filler.
    - b. Sealer Coat: Interior Acrylic primer/sealer.
    - c. Intermediate Coat: Interior alkyd matching topcoat.
    - d. Topcoat: Interior alkyd (semi-gloss).

B. Steel Substrates:

1. Latex Over Alkyd Primer System: MPI INT 5.1Q.
  - a. Prime Coat: Alkyd anticorrosive metal primer.
  - b. Intermediate Coat: Interior latex matching topcoat.
  - c. Topcoat: Interior latex (low sheen).

C. Galvanized-Metal Substrates:

1. Alkyd System: MPI INT 5.3C.
  - a. Prime Coat: Cementitious galvanized-metal primer.
  - b. Intermediate Coat: Interior alkyd matching topcoat.
  - c. Topcoat: Interior alkyd (eggshell).

D. Gypsum Board Substrates:

1. Acrylic Over Latex Primer System: MPI INT 9.2C.
  - a. Prime Coat: Interior latex primer/sealer.
  - b. Intermediate Coat: Interior Acrylic matching topcoat.
  - c. Topcoat: Interior alkyd (eggshell).
2. High-Performance Architectural Latex System: MPI INT 9.2B.
  - a. Prime Coat: Interior latex primer/sealer.
  - b. Intermediate Coat: High-performance architectural latex matching topcoat.
  - c. Topcoat: High-performance architectural latex (semi-gloss).

END OF SECTION 09912



## SECTION 09960 –HIGH PERFORMANCE WALL COATING SYSTEM

### Part 1: General

#### 1.01 System Description

- A. This system shall be applied to the prepared substrate(s) as defined in the plans as epoxy paint and strictly in accordance with the manufacturer’s recommendations.
- B. **Basis of Design:** Florock Floropoxy Wall Coating System is a high performance, non-sag, colorfast wall system that provides a tough, abrasion and chemical resistant surface. This VOC-compliant, low odor system results in a jointless “tile-like” finish with an optional urethane topcoat.

#### 1.02 Submittals

- A. Product Data
  - 1. Current edition of manufacturer’s product literature including physical data, chemical resistance, surface preparation, and application instructions.
- B. Samples
  - 1. A 6 inch (150 mm) square sample of the proposed system shall be submitted to represent the finished system.
- C. Warranty
  - 1. Manufacturer’s standard warranty
  - 2. Applicator’s standard warranty

#### 1.03 Quality Assurance

- A. Qualifications
  - 1. The manufacturer shall have a minimum of 10 years experience in the production, sales, and technical support of polymer-based floor coatings.
  - 2. The applicator shall have a minimum of 10 years experience in the application of polymer floor coatings to concrete floors documented in writing by Florock/Crawford Laboratories, Inc.
  - 3. Proposed suppliers of other products shall provide certification that they have 10 years experience in the production of polymer floor coatings and be required to meet all provisions of this specification as well as provide evidence for compatibility between components to the satisfaction of the Architect & Owner.
- B. Pre-Bid Conference
  - 1. A pre-bid conference should be held between prospective applicators and the Architect to review surface preparation, application, clean-up procedures, and design issues.

#### C. Packing and Shipping

1. All materials are to be delivered to the job site in the manufacturer's original packaging. The product code and other identification marks should be clearly marked and visible.

D. Storage and Protection

1. All material is to be stored in a cool, dry place out of the direct sunlight and away from any ignition sources. The applicator should refer to the manufacturer's literature and material safety data sheets for more information.
2. Material Safety Data Sheets are to be kept on site and made readily available for all personnel.
3. Keep containers sealed and ready for use.

1.04 Project Conditions

A. Environmental Requirements

1. Optimum air and substrate temperature for product application is between 55 F (13 C) and 95 F (35 C). Consult the manufacturer for product application suggestions for temperatures out of the specified range.
2. Verify the work environment is properly equipped with vapor barriers and perimeter drains.
3. Maintain proper lighting throughout the work environment; the lighting should be comparable to the final lighting level of the space.
4. Store and dispose of any waste in accordance with regulations of local authorities.

B. Safety Requirements

1. "No Smoking" signs shall be posted throughout the work area prior to application.
2. The owner shall be responsible for removing any foodstuffs from the work area.
3. Open flames, spark producing tools/items, and ignition sources shall be removed from the work area prior to application.
4. Only work-related personnel shall be allowed within the work area.

1.05 Warranty

A. Coordination

1. The manufacturer offers a full, one-year warranty against defects in materials. Warranties concerning the installation of the material are solely the responsibility of the applicator.

Part 2: Products

2.01 Manufacturer

- A. Crawford Laboratories, Inc.  
4165 South Emerald Avenue  
Chicago, IL 60609  
Phone: (773) 376-7132  
Fax: (773) 376-0945  
[www.florock.net](http://www.florock.net)

2.02 Materials

- A. Wall Coating
  1. Appropriate Florock 47, 48 or 49 series epoxy as a primer.
  2. Appropriate Florock 48 or 49 series epoxy as optional base coat
  3. Appropriate Florock 48 series epoxy as top coat
  4. Urethane topcoats

2.03. Properties

- A. The coating system should meet the following physical properties:

Cured System Properties

Tensile Strength ASTM D2370	1768 PSI
Elongation ASTM D2370	5%
Shore Hardness A/D ASTM D2240	100 / 75
Sag ASTM D4400	7
Sward Hardness ASTM D2240	70

Part 3: Execution

3.01 Inspection

- A. General
  1. Examine substrates and conditions with Applicator present, for compliance with requirements for maximum moisture content and other conditions affecting performance of work and notify the Architect of conditions detrimental to the proper and timely completion of the work. Do not proceed with the work until unsatisfactory conditions have been corrected by the contractor in a manner acceptable to the Architect.
  2. Maximum Moisture Content of Substrates: When measured with an electronic moisture meter as per manufacturer’s specifications.
  3. Verify compatibility with and suitability of substrates, including compatibility with existing finishes or primers.
  4. Begin coating application only after unsatisfactory conditions have been corrected and surfaces are dry.
  5. Coating application indicates acceptance of surfaces and conditions.

### 3.02 Preparation

#### A. Patching and Joint Preparation

1. Before application, the wall shall be examined for spalls, pits, holes, cracks, etc... These must be treated after preparation and before application. Patch with 100% solids epoxy Florock Floropoxy 47 or 49 series or FloroGel.

#### B. Surfaces

1. Concrete- Shot-blast or diamond grind as required to obtain clean, open porous concrete. Remove sufficient material to provide a sound surface, free of laitance, glaze, efflorescence, and any bond-inhibiting curing compounds or form release agents. Remove grease, oil, and other penetrating contaminants. Repair damaged and deteriorated concrete to acceptable condition; leave surface free of dust, dirt, laitance, and efflorescence.
2. Masonry Block- Clean, dry and coated with appropriate primer/filler.

#### C. Materials

1. Mix components when required, and prepare materials according to flooring system manufacturer's instructions.

### 3.03 Application

#### A. General

1. The system shall be installed in the order described below:
  - a. Substrate Preparation
  - b. Primer
  - c. Basecoat
  - d. Topcoat Application
2. Concrete surfaces on grade shall have been constructed with a vapor barrier to protect against the effects of vapor transmission and possible delamination of the system.
3. The surface should be dry prior to application of any of the aforementioned steps. Furthermore, the substrate shall always be kept clean, dry, and free of any contaminants.
4. The handling and mixture of any material associated with the installation of the system shall be in accordance with the manufacturer's recommendations and approved by the Architect.
5. The system shall follow the contours of the substrate unless otherwise specified by the Architect.
6. A neat finish with well defined boundaries and straight edges shall be provided by the applicator.

#### B: Wall System

1. Primer shall consist of Florock 100% solids epoxy.
2. Basecoat shall consist of Floropoxy 48 or 49 series.
3. Topcoat of Floropoxy 48 series
4. Urethane Topcoat of Florock's Florothane

3.04 Field Quality Control

A. Tests & Inspection

1. The following tests shall be performed by the applicator and recorded during application to submit to the Architect:
  - a. Temperature During Installation
    1. Air
    2. Substrate
    3. Dew Point

3.05 Cleaning

A. Disposal

1. Properly remove and dispose of any excess materials.

END OF SECTION 09960

## SECTION 10155 - TOILET COMPARTMENTS

### PART 1 - GENERAL

#### 1.1 RELATED DOCUMENTS

- A. Drawings and general provisions of the Contract, including General and Supplementary Conditions and Division 1 Specification Sections, apply to this Section.

#### 1.2 SUMMARY

- A. This Section includes solid-polymer units as follows:
  - 1. Toilet Enclosures: Floor anchored.
  - 2. Urinal Screens: Wall hung.
- B. Related Sections include the following:
  - 1. Division 10 "Toilet and Bath Accessories" for toilet tissue dispensers, grab bars, purse shelves, and similar accessories.

#### 1.3 SUBMITTALS

- A. Product Data: For each type of product indicated. Include construction details, material descriptions, dimensions of individual components and profiles, and finishes.
- B. Shop Drawings: Include plans, elevations, sections, details, and attachments to other work.
  - 1. Show locations of cutouts for compartment-mounted toilet accessories.
- C. Samples for Initial Selection: For each type of unit indicated.
- D. Samples for Verification: Of each type of color and finish required for units, prepared on **6-inch- (150-mm-)** square Samples of same thickness and material indicated for Work.

#### 1.4 QUALITY ASSURANCE

Comply with requirements in CID-A-A-60003, "Partitions, Toilets, Complete."

#### 1.5 PROJECT CONDITIONS

Field Measurements: Verify actual locations of walls, columns, ceilings, and other construction contiguous with toilet compartments by field measurements before fabrication and indicate measurements on Shop Drawings.

- 1. Established Dimensions: Where field measurements cannot be made without delaying the Work, establish dimensions and proceed with fabricating toilet compartments without field measurements. Coordinate wall, floor, ceilings, and other contiguous construction to ensure that actual dimensions correspond to established dimensions.

## PART 2 - PRODUCTS

### 2.1 SOLID-POLYMER UNITS

- A. Available Manufacturers: Subject to compliance with requirements, manufacturers offering products that may be incorporated into the Work include, but are not limited to, the following:
  - 1. Ampco.
  - 2. Comtec Industries.
  - 3. Santana Products, Inc.
- B. Door, Panel, and Pilaster Construction: Solid, high-density polyethylene (HDPE) or polypropylene (PP) panel material, not less than 1 inch (25 mm) thick, seamless, with eased edges, and with homogenous color and pattern throughout thickness of material.
  - 1. Color and Pattern: One color and pattern in each room as selected by Architect from manufacturer's full range of colors and patterns.
- C. Pilaster Shoes: Manufacturer's standard design; polymer.
  - 1. Polymer Color and Pattern: Matching pilaster.
- D. Brackets (Fittings):
  - 1. Full-Height (Continuous) Type: Manufacturer's standard design; polymer.
    - a. Polymer Color and Pattern: Matching pilaster.
- E. Heat-Sink Strip: Manufacturer's standard continuous, extruded-aluminum strip fastened to exposed bottom edges of solid-polymer components to prevent burning.

### 2.2 ACCESSORIES

- A. Hardware and Accessories: Manufacturer's standard design, heavy-duty operating hardware and accessories.
  - 1. Material: Chrome-plated brass.
- B. Anchorages and Fasteners: Manufacturer's standard exposed fasteners of stainless steel or chrome-plated steel or brass, finished to match hardware, with theft-resistant-type heads. Provide sex-type bolts for through-bolt applications. For concealed anchors, use hot-dip galvanized or other rust-resistant, protective-coated steel.

### 2.3 ABRICATION

- A. Floor-Anchored Units: Provide manufacturer's standard corrosion-resistant anchoring assemblies complete with threaded rods, lock washers, and leveling adjustment nuts at pilasters for structural connection to floor. Provide shoes at pilasters to conceal anchorage.
- B. Doors: Unless otherwise indicated, provide 24-inch- (610-mm-) wide in-swinging doors for standard toilet compartments and 36-inch- (914-mm-) wide out-swinging doors with a minimum 32-inch- (813-mm-) wide clear opening for compartments indicated to be accessible to people with disabilities.

1. Hinges: Manufacturer's standard self-closing type that can be adjusted to hold doors open at any angle up to 90 degrees.
2. Latch and Keeper: Manufacturer's standard surface-mounted latch unit designed for emergency access and with combination rubber-faced door strike and keeper. Provide units that comply with accessibility requirements of authorities having jurisdiction at compartments indicated to be accessible to people with disabilities.
3. Coat Hook: Manufacturer's standard combination hook and rubber-tipped bumper, sized to prevent door from hitting compartment-mounted accessories.
4. Door Bumper: Manufacturer's standard rubber-tipped bumper at out-swinging doors.
5. Door Pull: Manufacturer's standard unit at out-swinging doors that complies with accessibility requirements of authorities having jurisdiction. Provide units on both sides of doors at compartments indicated to be accessible to people with disabilities.

## PART 3 - EXECUTION

### 3.1 INSTALLATION

- A. General: Comply with manufacturer's written installation instructions. Install units rigid, straight, level, and plumb. Secure units in position with manufacturer's recommended anchoring devices.
  1. Maximum Clearances:
    - a. Pilasters and Panels: **1/2 inch (13 mm)**.
    - b. Panels and Walls: **1 inch (25 mm)**.
- B. Floor-Anchored Units: Set pilasters with anchors penetrating not less than **2 inches (50 mm)** into structural floor, unless otherwise indicated in manufacturer's written instructions. Level, plumb, and tighten pilasters. Hang doors and adjust so tops of doors are level with tops of pilasters when doors are in closed position.
- C. Wall-Hung Urinal Screens: Attach with continuous angle anchoring devices to suit supporting structure. Set units level and plumb and to resist lateral impact.

### 3.2 ADJUSTING

- A. Hardware Adjustment: Adjust and lubricate hardware according to manufacturer's written instructions for proper operation. Set hinges on in-swinging doors to hold doors open approximately 30 degrees from closed position when unlatched. Set hinges on out-swinging doors to return doors to fully closed position.

END OF SECTION 10155



## SECTION 10520 - FIRE-PROTECTION SPECIALTIES

### PART 1 - GENERAL

#### 1.1 RELATED DOCUMENTS

- A. Drawings and general provisions of the Contract, including General and Supplementary Conditions and Division 1 Specification Sections, apply to this Section.

#### 1.2 SUMMARY

- A. This Section includes the following:
  - 1. Portable fire extinguishers.
  - 2. Mounting brackets for fire extinguishers.

#### 1.3 SUBMITTALS

- A. Product Data: Include construction details, material descriptions, dimensions of individual components and profiles, and finishes for fire-protection cabinets.
  - 1. Fire Extinguishers: Include rating and classification.
- B. Maintenance Data: For fire extinguishers to include in maintenance manuals.

#### 1.4 QUALITY ASSURANCE

- A. Source Limitations: Obtain fire extinguishers through one source from a single manufacturer.
- B. NFPA Compliance: Fabricate and label fire extinguishers to comply with NFPA 10, "Portable Fire Extinguishers."
- C. Fire Extinguishers: Listed and labeled for type, rating, and classification by an independent testing agency acceptable to authorities having jurisdiction.
  - 1. Provide fire extinguishers approved, listed, and labeled by FMG.

#### 1.5 WARRANTY

- A. Special Warranty: Manufacturer's standard form in which manufacturer agrees to repair or replace components of portable fire extinguishers that fail in materials or workmanship within specified warranty period.
  - 1. Failures include, but are not limited to, the following:
    - a. Failure of hydrostatic test according to NFPA 10.
    - b. Faulty operation of valves or release levers.

2. Warranty Period: Six years from date of Substantial Completion.

## PART 2 - PRODUCTS

### 2.1 MANUFACTURERS

- A. In other Part 2 articles where titles below introduce lists, the following requirements apply to product selection:
  1. Available Manufacturers: Subject to compliance with requirements, manufacturers offering products that may be incorporated into the Work include, but are not limited to, manufacturers specified.

### 2.2 PORTABLE FIRE EXTINGUISHERS

- A. Available Manufacturers:
  1. Ansul Incorporated.
  2. Fire End & Croker Corporation.
  3. JL Industries, Inc.
  4. Kidde Fyrnetics.
  5. Larsen's Manufacturing Company.
- B. General: Provide fire extinguishers of type, size, and capacity for each mounting bracket indicated.
- C. Multipurpose Dry-Chemical Type in Steel Container: UL-rated 2-A:10-B:C, 5-lb (2.3-kg) nominal capacity, with monoammonium phosphate-based dry chemical in enameled-steel container.

### 2.3 MOUNTING BRACKETS

- A. Available Manufacturers:
  1. Buckeye Fire Equipment Company.
  2. JL Industries, Inc.
  3. Larsen's Manufacturing Company.
- B. Mounting Brackets: Manufacturer's standard galvanized steel, designed to secure fire extinguisher to wall or structure, of sizes required for types and capacities of fire extinguishers indicated, with plated or baked-enamel finish.
  1. Color: Red.
- C. Identification: Lettering complying with authorities having jurisdiction for letter style, size, spacing, and location. Locate as indicated by Architect.
  1. Identify bracket-mounted fire extinguishers with the words "FIRE EXTINGUISHER" in red letter decals applied to mounting surface.
    - a. Orientation: Horizontal.

## 2.4 FINISHES, GENERAL

- A. Comply with NAAMM's "Metal Finishes Manual for Architectural and Metal Products" for recommendations for applying and designating finishes.
- B. Protect mechanical finishes on exposed surfaces from damage by applying a strippable, temporary protective covering before shipping.
- C. Appearance of Finished Work: Variations in appearance of abutting or adjacent pieces are acceptable if they are within one-half of the range of approved Samples. Noticeable variations in the same piece are not acceptable. Variations in appearance of other components are acceptable if they are within the range of approved Samples and are assembled or installed to minimize contrast.

## 2.5 STEEL FINISHES

- A. Surface Preparation: Clean surfaces of dirt, oil, grease, mill scale, rust, and other contaminants that could impair paint bond using manufacturer's standard methods.
- B. Baked-Enamel Finish: Immediately after cleaning and pretreating, apply manufacturer's standard two-coat, baked-enamel finish consisting of prime coat and thermosetting topcoat. Comply with paint manufacturer's written instructions for applying and baking to achieve a minimum dry film thickness of **2 mils (0.05 mm)**.

## PART 3 - EXECUTION

### 3.1 EXAMINATION

- A. Examine fire extinguishers for proper charging and tagging.
  - 1. Remove and replace damaged, defective, or undercharged units.
- B. Proceed with installation only after unsatisfactory conditions have been corrected.
- C. General: Install fire-protection specialties in locations and at mounting heights indicated or, if not indicated, at heights indicated below:
  - 1. Mounting Brackets: **54 inches (1372 mm)** above finished floor to top of fire extinguisher.
- D. Mounting Brackets: Fasten mounting brackets to surfaces, square and plumb, at locations indicated.
- E. Identification: Apply vinyl lettering at locations indicated.

### 3.2 ADJUSTING AND CLEANING

- A. Remove temporary protective coverings and strippable films, if any, as fire-protection specialties are installed, unless otherwise indicated in manufacturer's written installation instructions.

END OF SECTION 10520

## SECTION 10801 - TOILET AND BATH ACCESSORIES

### PART 1 - GENERAL

#### 1.1 RELATED DOCUMENTS

- A. Drawings and general provisions of the Contract, including General and Supplementary Conditions and Division 1 Specification Sections, apply to this Section.

#### 1.2 SUMMARY

- A. This Section includes the following:
  - 1. Public-use washroom accessories.
  - 2. Underlavatory guards.
  - 3. Custodial accessories.
- B. Related Sections include the following:
  - 1. Division 9 Section "Ceramic Tile" for ceramic toilet and bath accessories.

#### 1.3 SUBMITTALS

- A. Product Data: For each type of product indicated. Include the following:
  - 1. Construction details and dimensions.
  - 2. Anchoring and mounting requirements, including requirements for cutouts in other work and substrate preparation.
  - 3. Material and finish descriptions.
  - 4. Features that will be included for Project.
  - 5. Manufacturer's warranty.
- B. Samples: Full size, for each accessory item to verify design, operation, and finish requirements.
  - 1. Approved full-size Samples will be returned and may be used in the Work.
- C. Product Schedule: Indicating types, quantities, sizes, and installation locations by room of each accessory required.
  - 1. Identify locations using room designations indicated on Drawings.
  - 2. Identify products using designations indicated on Drawings.
- D. Maintenance Data: For toilet and bath accessories to include in maintenance manuals.

#### 1.4 QUALITY ASSURANCE

- A. Source Limitations: For products listed together in the same articles in Part 2, provide products of same manufacturer unless otherwise approved by Architect.

## 1.5 COORDINATION

- A. Coordinate accessory locations with other work to prevent interference with clearances required for access by people with disabilities, and for proper installation, adjustment, operation, cleaning, and servicing of accessories.
- B. Deliver inserts and anchoring devices set into concrete or masonry as required to prevent delaying the Work.

## 1.6 WARRANTY

- A. Special Mirror Warranty: Manufacturer's standard form in which manufacturer agrees to replace mirrors that develop visible silver spoilage defects and that fail in materials or workmanship within specified warranty period.
  - 1. Warranty Period: 15 years from date of Substantial Completion.

## PART 2 - PRODUCTS

### 2.1 MATERIALS

- A. Stainless Steel: ASTM A 666, Type 304, 0.0312-inch (0.8-mm) minimum nominal thickness, unless otherwise indicated.
- B. Steel Sheet: ASTM A 1008/A 1008M, Designation CS (cold rolled, commercial steel), 0.0359-inch (0.9-mm) minimum nominal thickness.
- C. Galvanized Steel Sheet: ASTM A 653/A 653M, with G60 (Z180) hot-dip zinc coating.
- D. Galvanized Steel Mounting Devices: ASTM A 153/A 153M, hot-dip galvanized after fabrication.
- E. Fasteners: Screws, bolts, and other devices of same material as accessory unit and tamper-and-theft resistant where exposed, and of galvanized steel where concealed.
- F. Chrome Plating: ASTM B 456, Service Condition Number SC 2 (moderate service).
- G. Mirrors: ASTM C 1503, Mirror Glazing Quality, clear-glass mirrors, nominal 6.0 mm thick.
- H. ABS Plastic: Acrylonitrile-butadiene-styrene resin formulation.

### 2.2 PUBLIC-USE WASHROOM ACCESSORIES

- A. Available Manufacturers: Subject to compliance with requirements, manufacturers offering products that may be incorporated into the Work include, but are not limited to, the following:
  - 1. A & J Washroom Accessories, Inc.
  - 2. Bobrick Washroom Equipment, Inc.
  - 3. Bradley Corporation.

- B. Toilet Tissue – By Owner.
- C. Paper Towel Dispenser– By Owner.
- D. Liquid-Soap Dispenser– By Owner.
- E. Grab Bar: **Designation - gb**
  - 1. Mounting: Flanges with concealed fasteners.
  - 2. Material: Stainless steel, **0.05 inch (1.3 mm)** thick.
    - a. Finish: Smooth, No. 4, satin finish on ends and slip-resistant texture in grip area.
  - 3. Outside Diameter: **1-1/2 inches (38 mm)**.
  - 4. Configuration and Length: Straight, 36” long and 42” long.
  - 5. Location and quantity: (quantity shown 1<sup>st</sup> for 36” and 2nd 42” grabbars) –
- F. Sanitary-Napkin Disposal Unit– By Owner.
- G. Mirror Unit: **Designation - m**
  - 1. Frame: Stainless-steel angle, **0.05 inch (1.3 mm)** thick and Stainless steel, adjustable tilt.
    - a. Corners: Manufacturer's standard.
  - 2. Hangers: Produce rigid, tamper- and theft-resistant installation, using method indicated below.
    - a. One-piece, galvanized steel, wall-hanger device with spring-action locking mechanism to hold mirror unit in position with no exposed screws or bolts.
    - b. Wall bracket of galvanized steel, equipped with concealed locking devices requiring a special tool to remove.
  - 3. Size: .18 inches wide by 30 inches high.
- H. Surface Mounted Stainless Steel Shelf: **Designation – sms**
  - 1. Material:
    - a. 22 gauge stainless steel flanges and support arms,
    - b. 16 gauge stainless steel mounting brackets and concealed wall plates with fasteners.
    - c. Type 304 bright polished finish stainless steel shelf with roll-formed edges.
  - 2. Configuration and Length: 26” long x 5 ¾” deep.

### 2.3 UNDERLAVATORY GUARDS

- A. Available Manufacturers: Subject to compliance with requirements, manufacturers offering products that may be incorporated into the Work include, but are not limited to, the following:
  - 1. Plumberex Specialty Products, Inc.
  - 2. TCI Products.
  - 3. Truebro, Inc.

B. Underlavatory Guard: **Designation - ulg**

1. Description: Insulating pipe covering for supply and drain piping assemblies, that prevent direct contact with and burns from piping, and allow service access without removing coverings.
2. Material and Finish: Antimicrobial, molded-plastic, white.

2.4 CUSTODIAL ACCESSORIES

A. Available Manufacturers: Subject to compliance with requirements, manufacturers offering products that may be incorporated into the Work include, but are not limited to, the following:

1. A & J Washroom Accessories, Inc.
2. Bobrick Washroom Equipment, Inc.
3. Bradley Corporation.

B. Mop and Broom Holder: **Designation - mbh**

1. Description: Unit with shelf, hooks, holders, and rod suspended beneath shelf.
2. Length: **36 inches (914 mm)**.
3. Hooks: Three.
4. Mop/Broom Holders: Four, spring-loaded, rubber hat, cam type.
5. Material and Finish: Stainless steel, No. 4 finish (satin).
  - a. Shelf: Not less than nominal **0.05-inch- (1.3-mm-)** thick stainless steel.
  - b. Rod: Approximately **1/4-inch- (6-mm-)** diameter stainless steel.

2.5 FABRICATION

- A. General: Fabricate units with tight seams and joints, and exposed edges rolled. Hang doors and access panels with full-length, continuous hinges. Equip units for concealed anchorage and with corrosion-resistant backing plates.
- B. Keys: Provide universal keys for internal access to accessories for servicing and resupplying. Provide minimum of six keys to Owner's representative.

PART 3 - EXECUTION

3.1 INSTALLATION

- A. Install accessories according to manufacturers' written instructions, using fasteners appropriate to substrate indicated and recommended by unit manufacturer. Install units level, plumb, and firmly anchored in locations and at heights indicated.
- B. Grab Bars: Install to withstand a downward load of at least **250 lbf (1112 N)**, when tested according to method in ASTM F 446.

3.2 ADJUSTING AND CLEANING

- A. Adjust accessories for unencumbered, smooth operation. Replace damaged or defective items.
- B. Remove temporary labels and protective coatings.
- C. Clean and polish exposed surfaces according to manufacturer's written recommendations.

END OF SECTION 10801



# STEEL ROLLING DOOR

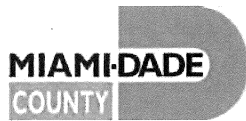

DEPARTMENT OF REGULATORY AND ECONOMIC RESOURCES (RER)  
BOARD AND CODE ADMINISTRATION DIVISION  
**NOTICE OF ACCEPTANCE (NOA)**

MIAMI-DADE COUNTY  
PRODUCT CONTROL SECTION  
11805 SW 26 Street, Room 208  
Miami, Florida 33175-2474  
T (786) 315-2590 F (786) 315-2599  
[www.miamidade.gov/economy](http://www.miamidade.gov/economy)

**Cornell Iron Works, Inc.**  
24 Elmwood Avenue  
Mountaintop, PA 18707

**SCOPE:** This NOA is being issued under the applicable rules and regulations governing the use of construction materials. The documentation submitted has been reviewed and accepted by Miami-Dade County RER-Product Control Section to be used in Miami-Dade County and other areas where allowed by the Authority Having Jurisdiction (AHJ). This NOA shall not be valid after the expiration date stated below. The Miami-Dade County Product Control Section (In Miami-Dade County) and/or the AHJ (in areas other than Miami-Dade County) reserve the right to have this product or material tested for quality assurance purposes. If this product or material fails to perform in the accepted manner, the manufacturer will incur the expense of such testing and the AHJ may immediately revoke, modify, or suspend the use of such product or material within their jurisdiction. RER reserves the right to revoke this acceptance if it is determined by Miami-Dade County Product Control Section that this product or material fails to meet the requirements of the applicable building code.

This product is approved as described herein and has been designed to comply with the Florida Building Code, including the High Velocity Hurricane Zone.

**DESCRIPTION: Steel Rolling Door up to 14ft-5in Wide (80 FPS Impact)**

**APPROVAL DOCUMENT:** Drawing No. **ES-16-56-CIW**, titled “14’-5” Wide 65 PSF 80 FPS Non-Insulated Rolling Steel Door”, sheets 1 through 6 of 6, dated 09/10/2014, with revision **B** dated 01/23/2020, prepared by Cornell Iron Works, Inc., signed and sealed by Shawn Patrick Kelley, P.E. on 03/18/2020, bearing the Miami-Dade County Product Control revision stamp with the Notice of Acceptance number and expiration date by the Miami-Dade County Product Control Section.

**MISSILE IMPACT RATING: Large and Small Missile Impact Resistant**

**LABELING:** A permanent label with the manufacturer’s name or logo, one of the 2 manufacturing addresses on drawings, model number, the positive and negative design pressure rating, indicate impact rate if applicable, installation instruction drawing reference number, approval number (NOA), the applicable test standards, and the statement reading ‘Miami-Dade County Product Control Approved’ is to be located on the door’s side track, bottom angle, or inner surface of a panel.

**RENEWAL** of this NOA shall be considered after a renewal application has been filed and there has been no change in the applicable building code negatively affecting the performance of this product.

**TERMINATION** of this NOA will occur after the expiration date or if there has been a revision or change in the materials, use, and/or manufacture of the product or process. Misuse of this NOA as an endorsement of any product, for sales, advertising or any other purposes shall automatically terminate this NOA. Failure to comply with any section of this NOA shall be cause for termination and removal of NOA.

**ADVERTISEMENT:** The NOA number preceded by the words Miami-Dade County, Florida, and followed by the expiration date may be displayed in advertising literature. If any portion of the NOA is displayed, then it shall be done in its entirety.

**INSPECTION:** A copy of this entire NOA shall be provided to the user by the manufacturer or its distributors and shall be available for inspection at the job site at the request of the Building Official.

This NOA revises **NOA # 20-0416.17** and consists of this page 1 and evidence pages E-1 and E-2, as well as approval document mentioned above.

The submitted documentation was reviewed by **Carlos M. Utrera, P.E.**



NOA-No. 20-0625.07  
Expiration Date: July 9, 2025  
Approval Date: December 10, 2020  
Page 1

**Cornell Iron Works, Inc.**

**NOTICE OF ACCEPTANCE: EVIDENCE SUBMITTED**

**1. EVIDENCE SUBMITTED UNDER PREVIOUS NOA's**

**A. DRAWINGS “Submitted under NOA # 15-0112.06”**

1. Drawing No. **ES-16-56-CIW**, titled “14'-5” Wide 65 PSF 80 FPS Non-Insulated Rolling Steel Door”, sheets 1 through 6 of 6, dated 09/10/2014, with revision A dated 03/27/2015, prepared by Cornell Iron Works, Inc., signed and sealed by Joseph Dixon, Jr., P.E.

**B. TESTS “Submitted under NOA # 15-0112.04”**

1. Test reports on 1) Uniform Static Air Pressure Test, Loading per FBC, TAS 202-94  
2) Large Missile Impact Test per FBC, TAS 201-94 (Level ‘E’)  
3) Cyclic Wind Pressure Loading per FBC, TAS 203-94  
4) Forced Entry Test, per FBC, TAS 202-94  
5) Tensile Test per ASTM E8-08,  
along with marked-up drawings and installation diagram of C20 Roll-up Garage Doors, prepared by Intertek/Architectural Testing, Inc., compliance letter and Test Report No. **D1278.01-109-18**, dated 01/29/2014, with revision 1 dated 03/25/2015, signed and sealed by Michael D. Stremmel, P.E.
2. Test report on Salt Spray Performance Test per ASTM B117-09 of G90 unpainted and G40 painted samples, prepared by Intertek, compliance letter and Test Report No. **G100075502MID-002**, dated 05/26/2010, signed and sealed by Rick Curkeet, P.E.

**C. CALCULATIONS “Submitted under NOA # 15-0112.04”**

1. Calculations prepared by Joseph H. Dixon, Jr., P.E., dated 10/03/2014, signed and sealed by Joseph H. Dixon, Jr., P.E.

**D. QUALITY ASSURANCE**

1. Miami-Dade Department of Regulatory and Economic Resources (RER).

**E. MATERIAL CERTIFICATIONS**

1. None.

**F. STATEMENTS “Submitted under NOA # 15-0112.06”**

1. Private label agreement dated 12/11/2014.
2. Statement letter of code conformance to 2010 and 5<sup>th</sup> edition (2014) FBC issued by Joseph H. Dixon, Jr., P.E., dated 01/03/2015, signed and sealed by Joseph H. Dixon, Jr., P.E. “Submitted under NOA # 15-0112.04”
3. Statement letter of no financial interest issued by Joseph H. Dixon, Jr., P.E., dated 01/03/2015, signed and sealed by Joseph H. Dixon, Jr., P.E.



**Carlos M. Utrera, P.E.**

**Product Control Examiner**

**NOA-No. 20-0625.07**

**Expiration Date: July 9, 2025**

**Approval Date: December 10, 2020**

NOTICE OF ACCEPTANCE: EVIDENCE SUBMITTED

2. EVIDENCE SUBMITTED UNDER PREVIOUS NOA # 20-0416.17

A. DRAWINGS

1. Drawing No. **ES-16-56-CIW**, titled "14'-5" Wide 65 PSF 80 FPS Non-Insulated Rolling Steel Door", sheets 1 through 6 of 6, dated 09/10/2014, with revision **B** dated 01/23/2020, prepared by Cornell Iron Works, Inc., signed and sealed by Shawn Patrick Kelley, P.E. on 03/18/2020.

B. TESTS

1. None.

C. CALCULATIONS "*Submitted under NOA # 18-0125.02*"

1. Calculations prepared by Moment Engineering+ Design, LLC, dated 01/12/2018, signed and sealed by Shawn Patrick Kelley, P.E.

D. QUALITY ASSURANCE

1. Miami-Dade Department of Regulatory and Economic Resources (RER).

E. MATERIAL CERTIFICATIONS

1. None.

F. STATEMENTS

1. Statement letter of code conformance to **FBC 6<sup>th</sup> Edition (2017)** and of no financial interest, dated March 21, 2020, issued by Moment Engineering+ Design, LLC, signed and sealed by Shawn Patrick Kelley, P.E.
2. Private label agreement dated 02/27/2020.

3. NEW EVIDENCE SUBMITTED

A. DRAWINGS

1. None.

B. TESTS

1. None.

C. CALCULATIONS

1. None.

D. QUALITY ASSURANCE

1. Miami-Dade Department of Regulatory and Economic Resources (RER).

E. MATERIAL CERTIFICATIONS

1. None.

F. STATEMENTS

1. Statement letter of code conformance to **FBC 7<sup>th</sup> Edition (2020)** and of no financial interest, dated August 12, 2020, issued by Moment Engineering + Design, LLC, signed and sealed by Shawn Patrick Kelley, P.E.



Carlos M. Utrera, P.E.

Product Control Examiner

NOA-No. 20-0625.07

Expiration Date: July 9, 2025

Approval Date: December 10, 2020

L'TR	REVISION	DATE	BY	E.C.O.
*	ORIGINAL ISSUE	09/10/2014	TJE	1614
A	REVISED NOTES	03/27/2015	TJE	1614
B	REVISED TITLE BLOCK; HOOD SUPPORT UPDATE	01/23/2020	MAN	2026

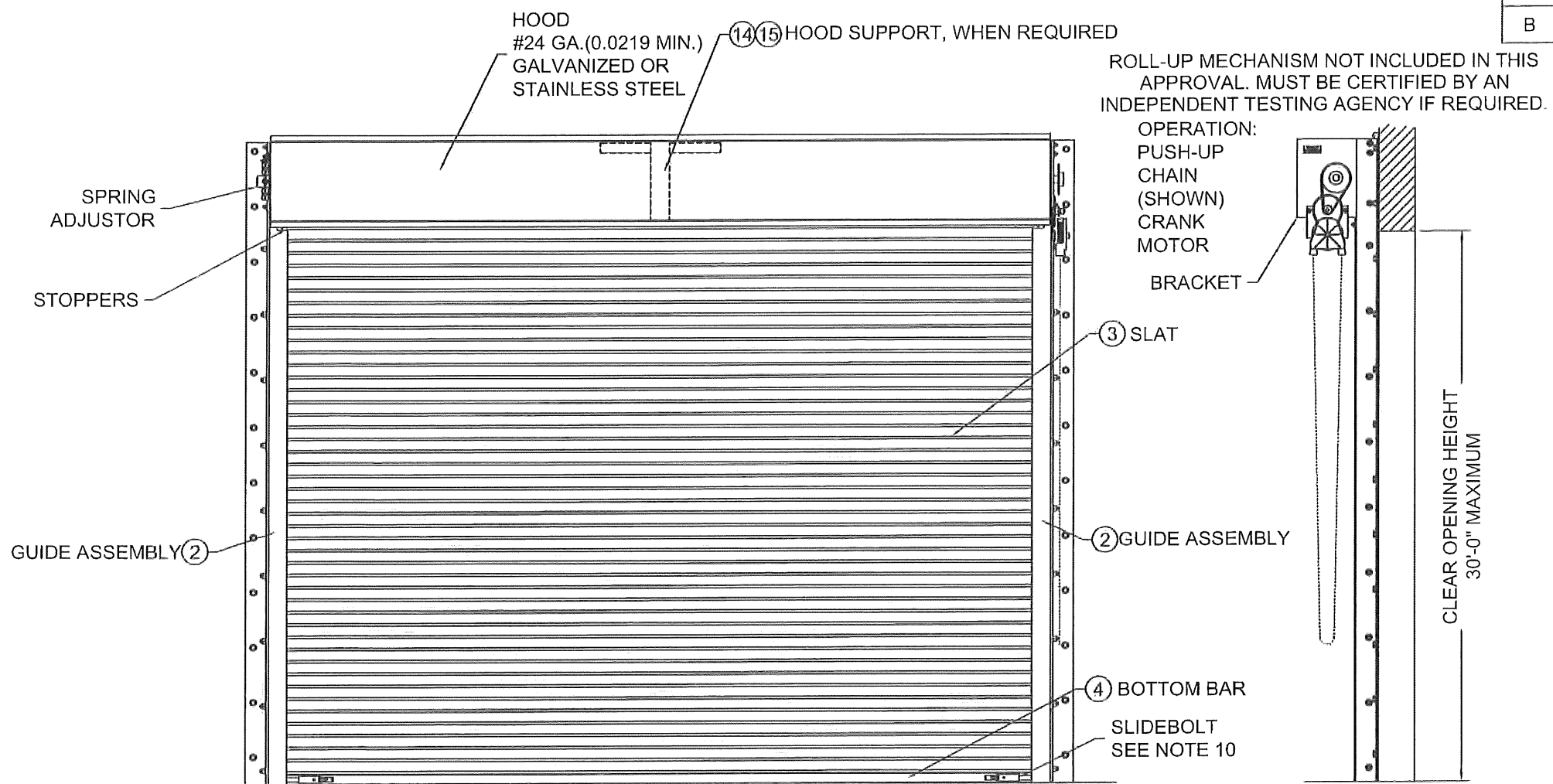

- NOTES:
- THIS ROLL-UP DOOR SYSTEM IS DESIGNED IN ACCORDANCE WITH THE FLORIDA BUILDING CODE, AS A LARGE MISSILE IMPACT RESISTANT SYSTEM.
  - POSITIVE AND NEGATIVE DESIGN PRESSURE CALCULATIONS SHALL BE PERFORMED FOR SPECIFIC JOBS IN ACCORDANCE WITH ASCE 7 *MINIMUM DESIGN LOADS FOR BUILDINGS AND OTHER STRUCTURES*. WIND LOADS DETERMINED FOR OPENINGS SHALL BE LESS THAN OR EQUAL TO DOOR DESIGN PRESSURES NOTED BELOW.  
 POSITIVE DESIGN LOAD = 65 PSF  
 NEGATIVE DESIGN LOAD = 65 PSF
  - THE DETAILS AND SPECIFICATIONS SHOWN HEREIN REPRESENT THE PRODUCTS TESTED FOR UNIFORM STATIC AIR PRESSURE IN CONFORMANCE WITH DADE COUNTY PROTOCOLS TAS 201, 202 AND 203.
  - TESTING PERFORMED BY ARCHITECTURAL TESTING, INC. (YORK, PENNSYLVANIA) TEST REPORT No. D1278.01-109-18.
  - SUPERIMPOSED LOADS ON THE JAMBS FROM THIS DOOR ARE DESIGNATED AS F1, F2, AND F3 HEREIN. CONTRACTORS SHALL HAVE FLORIDA REGISTERED PROFESSIONAL ENGINEER VERIFY ADEQUACY OF BUILDING STRUCTURE TO RESIST SUPERIMPOSED LOAD F1, F2, AND F3.
  - ALL WELDING SHALL BE PERFORMED BY QUALIFIED WELDERS IN ACCORDANCE WITH AWS SPECIFICATIONS, LATEST EDITION. ALL WELDING ELECTRODES SHALL CONFORM TO AWS A5.1, GRADE E-70. MINIMUM WELDING PROCESS SHALL BE ARC WELDING AWS E7014 OR MIG WELDING AWS ER70S-6.
  - ANCHOR NOTES:  
 A. EMBEDMENT DEPTH DOES NOT INCLUDE STUCCO FINISH.  
 B. ANCHORS SHALL BE INSTALLED IN ACCORDANCE WITH MANUFACTURERS SPECIFICATIONS.
  - DOOR MAY BE INSTALLED ON THE INSIDE OR OUTSIDE OF AN EXTERIOR WALL.
  - A 33% INCREASE IN ALLOWABLE STRESS HAS NOT BEEN USED IN THE DESIGN OF THIS PRODUCT.
  - SLIDE BOLTS ARE NOT REQUIRED FOR WINDLOAD RESISTANCE. SLIDE BOLTS ARE ONLY REQUIRED ON PUSH UP OPERATED UNITS FOR FORCED ENTRY RESISTANCE. LOCKING IS TO BE PROVIDED BY OTHERS OR AS CYLINDER LOCKS BY CORNELL IRON WORKS.
  - ENDLOCK/WINDLOCKS AND WINDLOCKS ARE SECURED TO EACH END OF ALTERNATING SLATS WITH 3 1/4" RIVETS PER END RESULTING IN CONTINUOUS SLAT WINDLOCK SUPPORT.
  - GUIDE ASSEMBLY AND BOTTOM BAR ARE TO BE PROTECTED FROM CORROSION WITH POLYESTER POWDER COATING WHEN NOT MINIMUM G90 GALVANIZED STEEL OR STAINLESS STEEL.

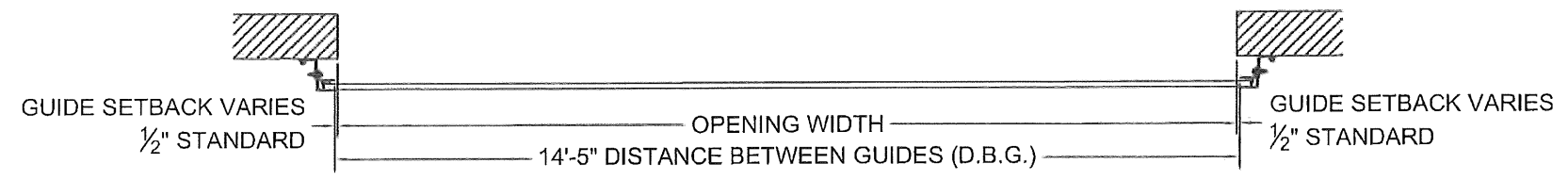

① OVERALL DOOR ASSEMBLY  
1:32 SCALE

**PRODUCT REVISED**  
 as complying with the Florida Building Code  
 NOA-No. **20-0925.07**  
 Expiration Date **07/09/2025**  
 By *[Signature]*  
 Miami-Dade Product Control

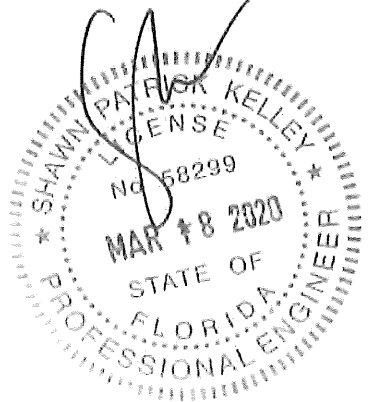

	24 ELMWOOD AVE 1901 S. LITCHFIELD RD MOUNTAINTOP, PA GOODYEAR, AZ P: 800.233.8366 F: 800.526.0841 E: ADS@CORNELLIRON.COM	Unless otherwise specified, dimensions are in inches & tolerances are:  0.000 = +/- 0.031 FRACTIONAL = +/- 1/32 ANGLES = +/- 1/2 DEG	
	<b>TITLE:</b> MIAMI DADE COUNTY APPROVED 14'-5" WIDE 65 PSF 80 FPS NON-INSULATED ROLLING STEEL DOOR	<b>DRAWN BY:</b> TJE <b>SIZE:</b> B <b>SCALE:</b> AS NOTED <b>SHEET:</b> 1/6	<b>DWG NO:</b> ES-16-56-CIW

L'TR	REVISION	DATE	BY	E.C.O.
*	ORIGINAL ISSUE	09/10/2014	TJE	1614
A	REVISED NOTES	03/27/2015	TJE	1614
B	REVISED TITLE BLOCK; HOOD SUPPORT UPDATE	01/23/2020	MAN	2026

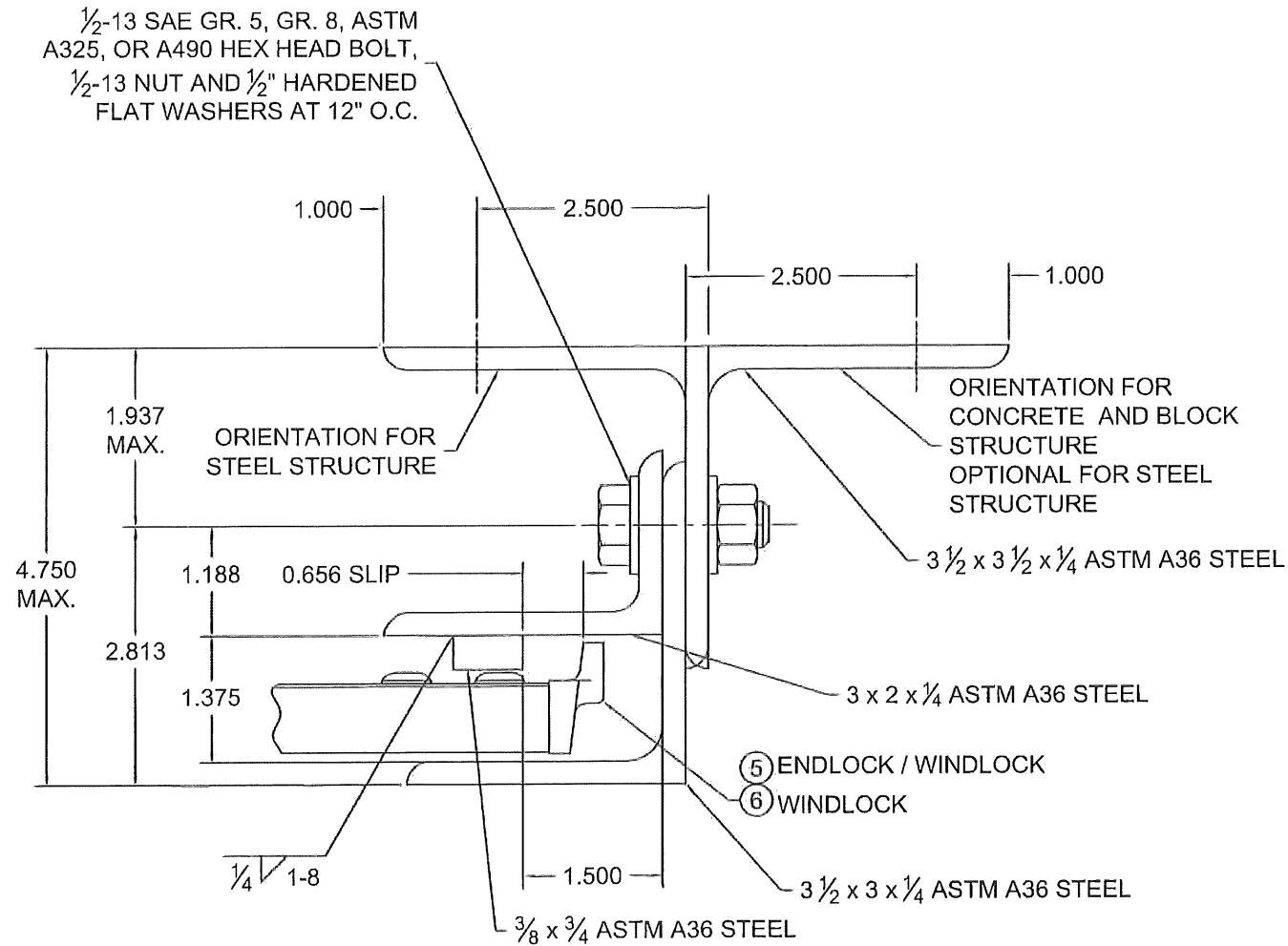

② GUIDE ASSEMBLY DETAIL  
1:2 SCALE

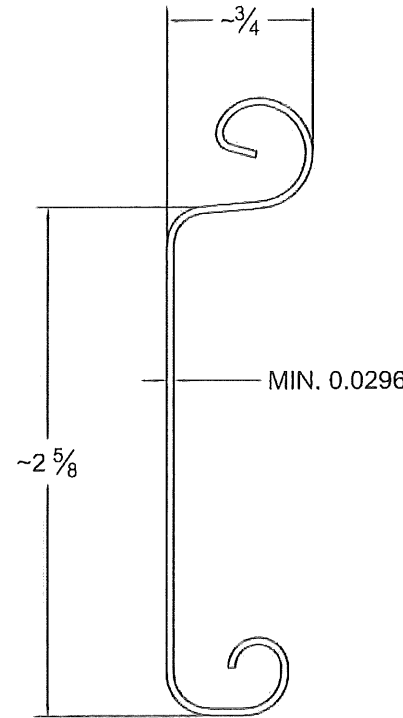

③ SLAT DETAIL  
TYPICAL SECTION

ASTM A653 HSLAS TYPE B GRADE 40 G40 WITH POLYESTER BASED COATING OR  
ASTM A653 HSLAS TYPE A GRADE 40 G40 WITH POLYESTER BASED COATING OR  
ASTM A653 STRUCTURAL STEEL GRADE 40 G40 WITH POLYESTER BASED COATING  
OR TYPE 304 STAINLESS STEEL (MIN. YIELD 40,000 psi)  
OR TYPE 316 STAINLESS STEEL (MIN. YIELD 40,000 psi)  
OR TYPE 430 STAINLESS STEEL (MIN. YIELD 40,000 psi)  
OR TYPE 201 STAINLESS STEEL (MIN. YIELD 40,000 psi)  
FULL SCALE

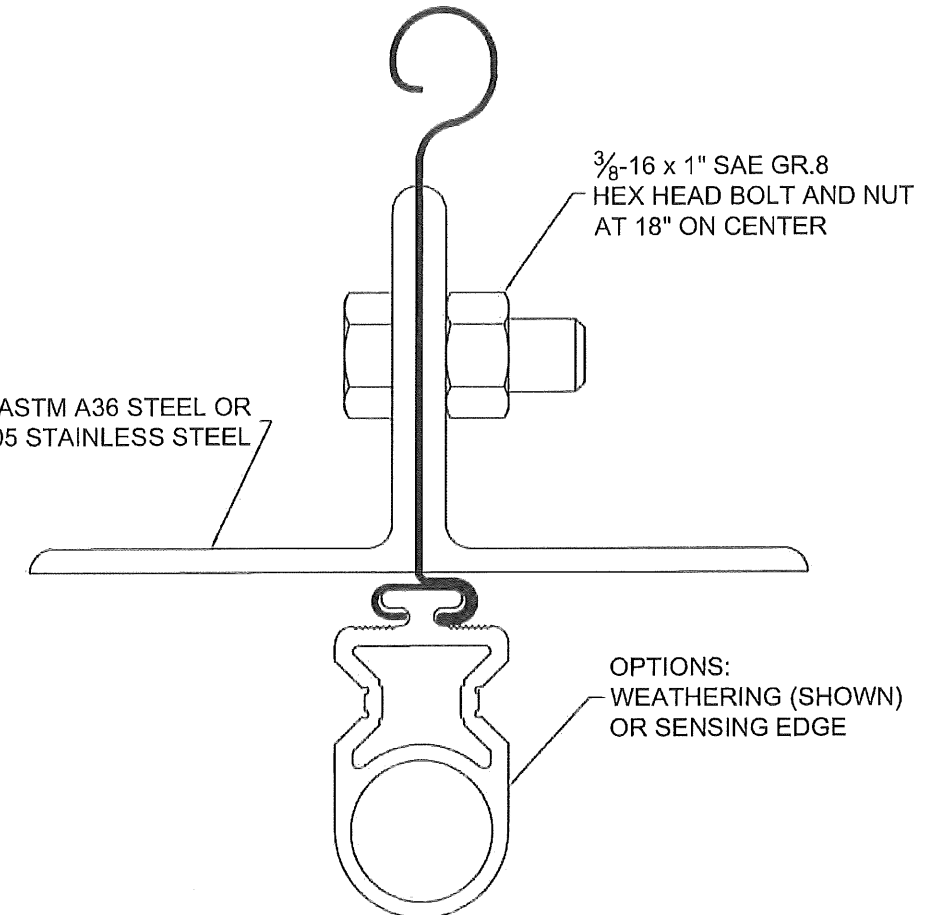

④ BOTTOM BAR DETAIL  
TYPICAL SECTION  
FULL SCALE

**PRODUCT REVISED**  
as complying with the Florida  
Building Code  
NOA-No. **20-0925.07**  
Expiration Date **07/09/2025**  
By *[Signature]*  
Miami-Dade Product Control



	24 ELMWOOD AVE 1901 S. LITCHFIELD RD MOUNTAINTOP, PA GOODYEAR, AZ		Unless otherwise specified, dimensions are in inches & tolerances are:		
	P: 800.233.8366 F: 800.526.0841 E: ADS@CORNELLIRON.COM		0.000 = +/- 0.031 FRACTIONAL = +/- 1/32 ANGLES = +/- 1/2 DEG		
TITLE: MIAMI DADE COUNTY APPROVED 14'-5" WIDE 65 PSF 80 FPS NON-INSULATED ROLLING STEEL DOOR		DRAWN BY: <b>TJE</b>	SIZE: <b>B</b>	SCALE: <b>AS NOTED</b>	SHEET: <b>2/6</b>
		DWG NO: <b>ES-16-56-CIW</b>			

L'TR	REVISION	DATE	BY	E.C.O.
*	ORIGINAL ISSUE	09/10/2014	TJE	1614
A	REVISED NOTES	03/27/2015	TJE	1614
B	REVISED TITLE BLOCK; HOOD SUPPORT UPDATE	01/23/2020	MAN	2026

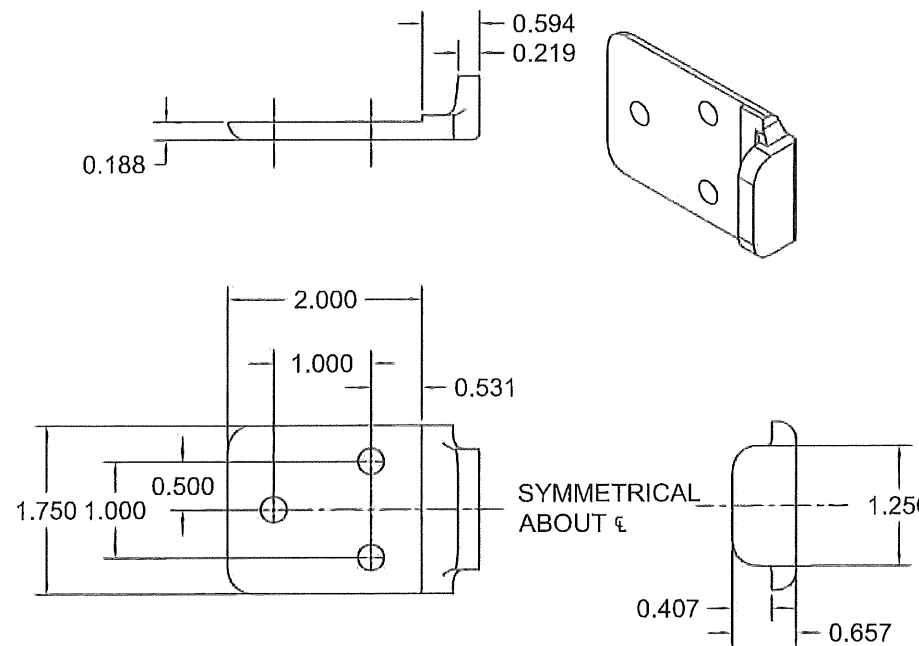
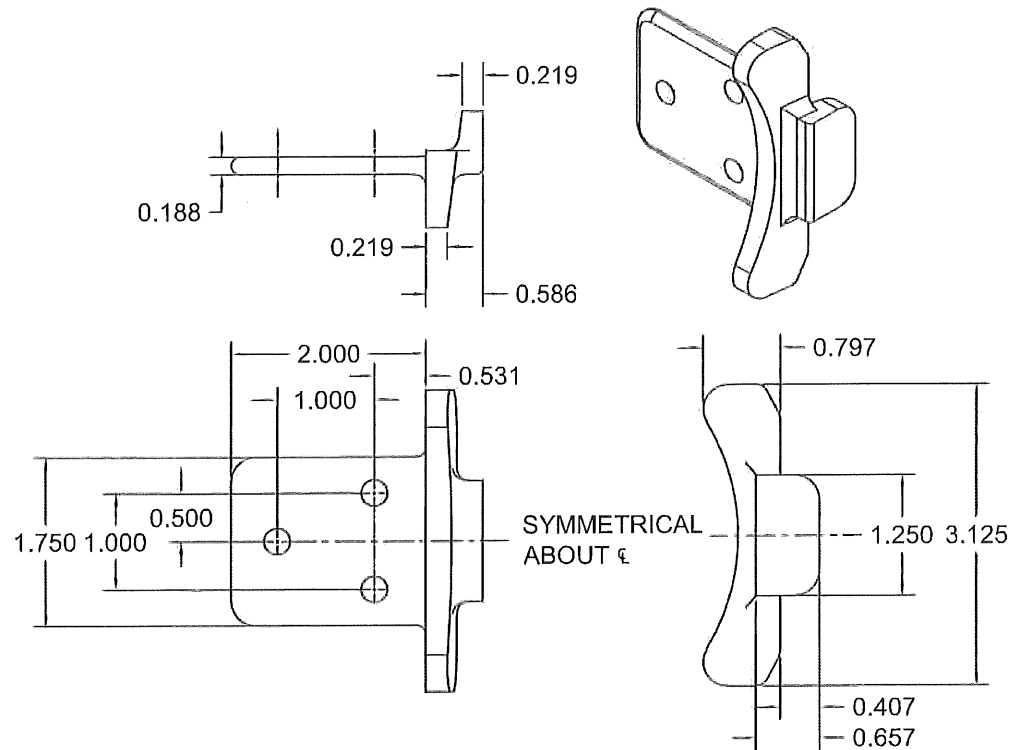

1/2-13 x 1 1/2"  
CARRIAGE BOLT GR.5  
1/2" FLAT WASHER  
1/2-13 HEX NUT

1/2-13 x 1 1/2"  
CARRIAGE BOLT GR.5  
1/2" FLAT WASHER  
1/2-13 HEX NUT  
THIS FASTENER ON 17"  
AND LARGER COILS

1/2-13 x 1 1/2"  
CARRIAGE BOLT GR.5  
1/2" FLAT WASHER  
1/2-13 HEX NUT

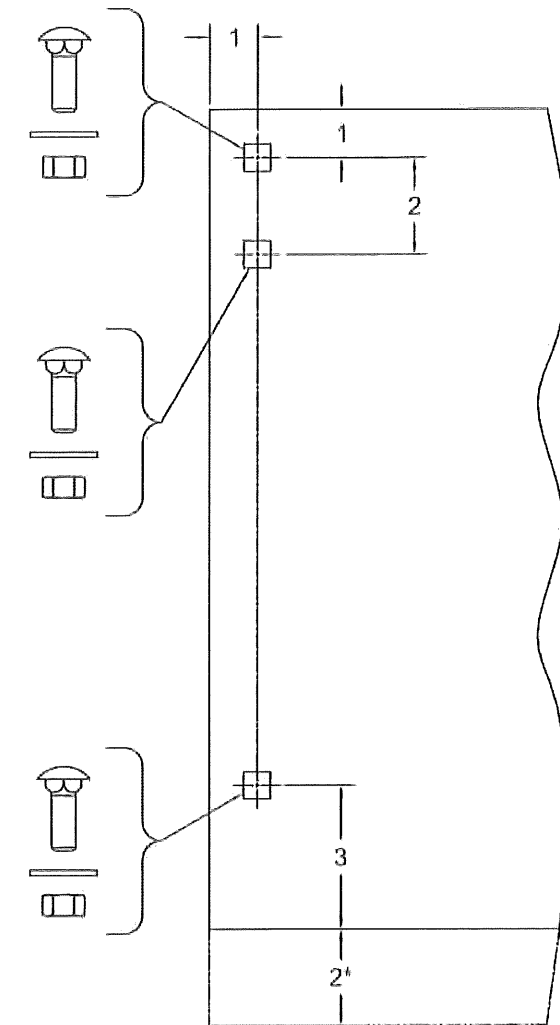

⑤ ENDLOCK / WINDLOCK DETAIL  
CAST MALLEABLE IRON ASTM A47, GRADE 32510, OR  
DUCTILE IRON PER ASTM A536 GRADE 65-45-12, GALVANIZED IN ACCORDANCE WITH  
ASTM A123, GRADE 85 ZINC-COATING  
1/2 SCALE

⑥ WINDLOCK DETAIL  
CAST MALLEABLE IRON ASTM A47, GRADE 32510, OR  
DUCTILE IRON PER ASTM A536 GRADE 65-45-12, GALVANIZED IN  
ACCORDANCE WITH ASTM A123, GRADE 85 ZINC-COATING  
1/2 SCALE

⑦ BRACKET MOUNTING DETAIL  
0.172 MIN. THICKNESS  
\* 2" EXTENSION WHEN 8" AND LARGER SHAFT ASSEMBLY IS SUPPLIED  
1/4 SCALE

**PRODUCT REVISED**  
as complying with the Florida  
Building Code  
NOA-No. **20-0925.07**  
Expiration Date **07/09/2025**  
By *[Signature]*  
Miami-Dade Product Control

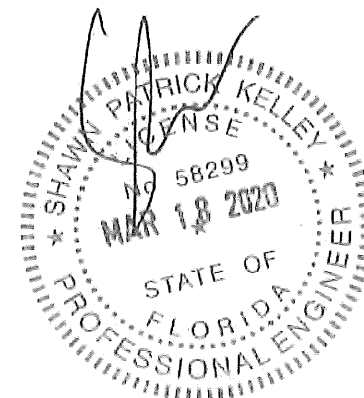

	24 ELMWOOD AVE 1901 S. LITCHFIELD RD MOUNTAINTOP, PA GOODYEAR, AZ  P: 800.233.8366 F: 800.526.0841 E: ADS@CORNELLIRON.COM	Unless otherwise specified, dimensions are in inches & tolerances are:  0.000 = +/- 0.031 FRACTIONAL = +/- 1/32 ANGLES = +/- 1/2 DEG
	TITLE: <b>MIAMI DADE COUNTY APPROVED</b> <b>14'-5" WIDE 65 PSF 80 FPS</b> <b>NON-INSULATED ROLLING STEEL DOOR</b>	DRAWN BY: <b>TJE</b> DWG NO: <b>ES-16-56-CIW</b>

CONCRETE FASTENER SPACING			
CONCRETE STRENGTH (psi)	MAXIMUM FASTENER SPACING (in.)		
	HILTI	SIMPSON	ITW REDHEAD
2000	4	4 3/4	-
3000	5	6	3 1/8
4000	6	7	6 1/2

L/TR	REVISION	DATE	BY	E.C.O.
*	ORIGINAL ISSUE	09/10/2014	TJE	1614
A	REVISED NOTES	03/27/2015	TJE	1614
B	REVISED TITLE BLOCK; HOOD SUPPORT UPDATE	01/23/2020	MAN	2026

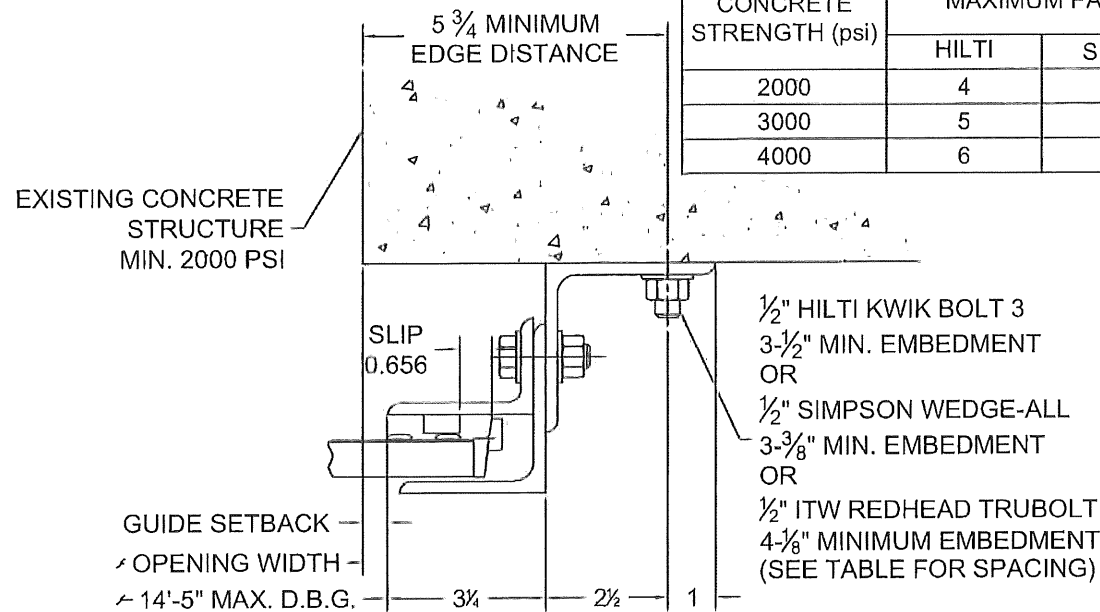

⑧ GUIDE ASSEMBLY  
CONCRETE STRUCTURE  
(Z-GUIDE)

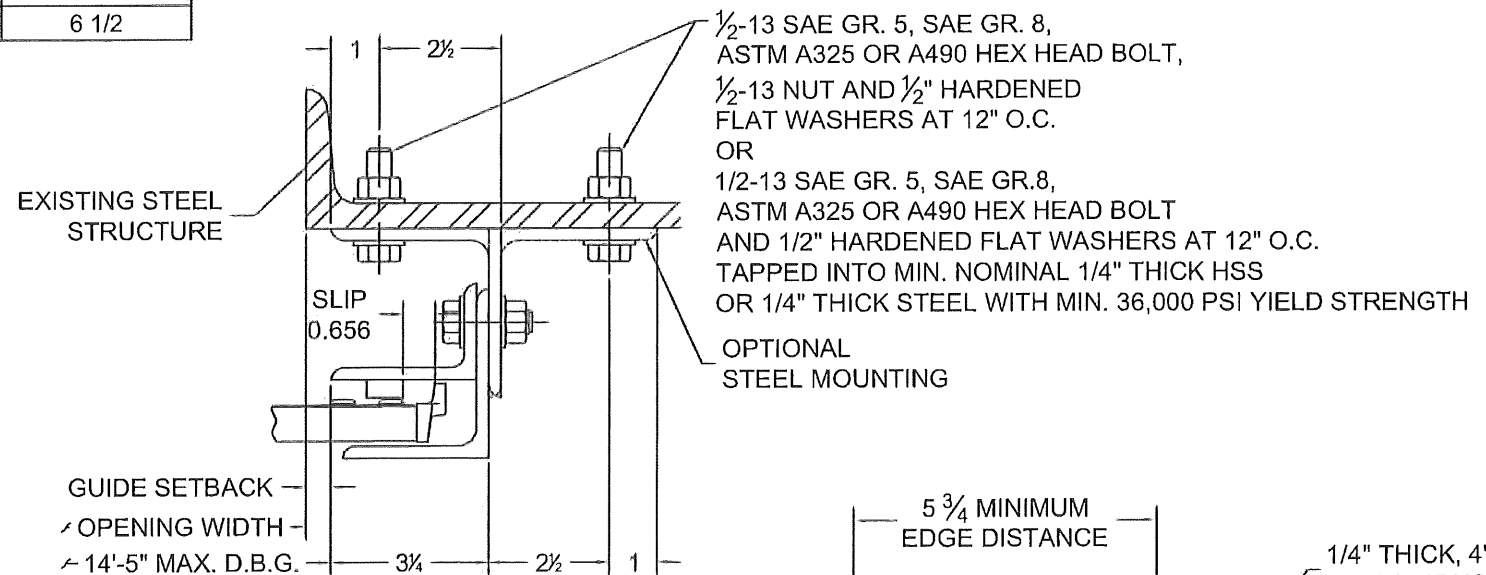

⑨ GUIDE ASSEMBLY  
STEEL STRUCTURE  
(Z-GUIDE OR E-GUIDE)

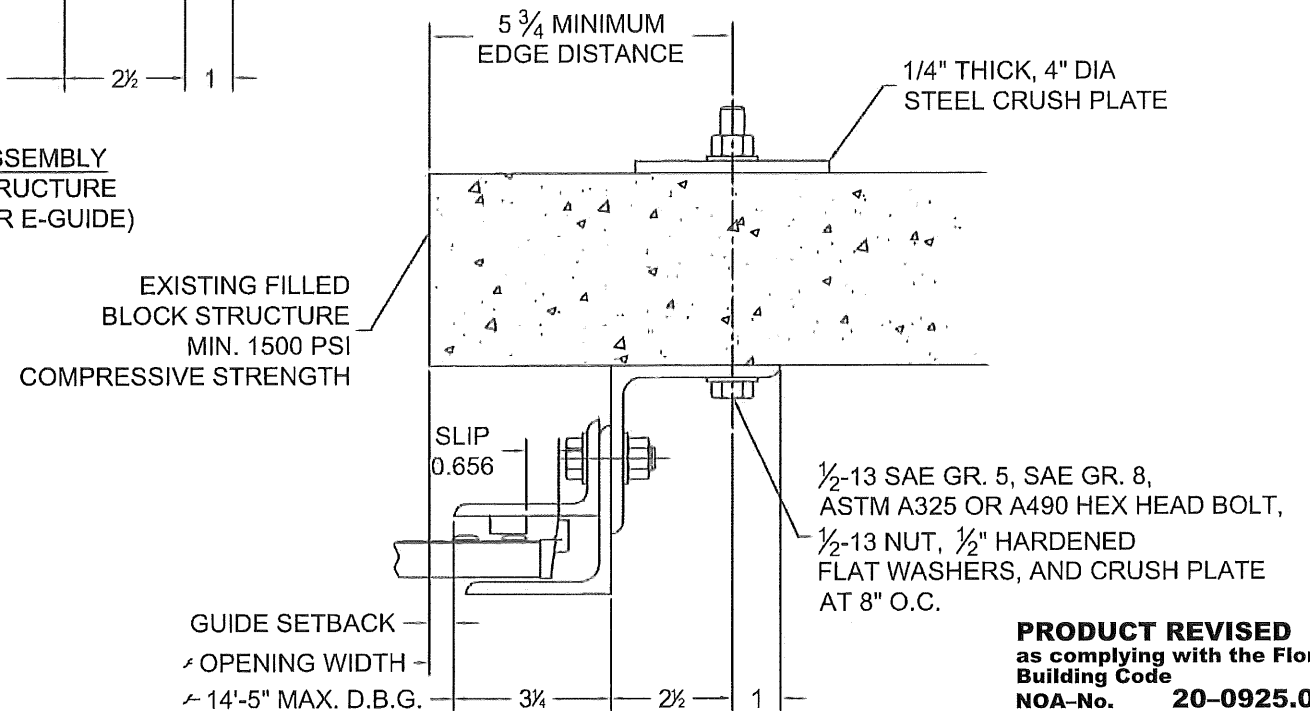

⑪ GUIDE ASSEMBLY  
FILLED BLOCK STRUCTURE  
(Z-GUIDE)

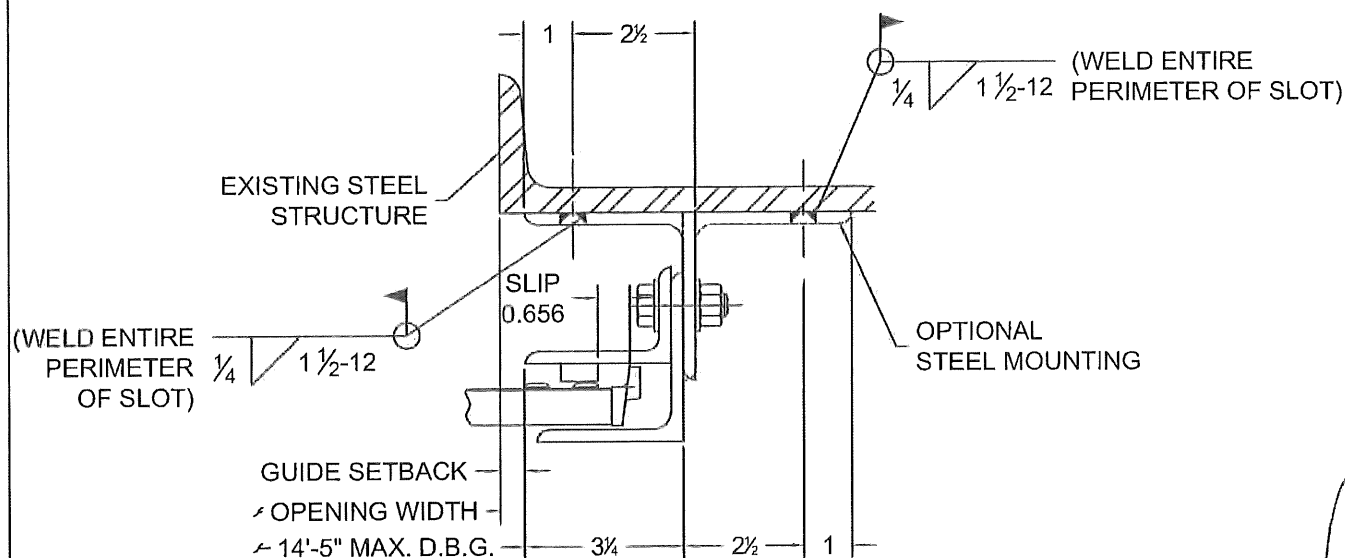

⑩ GUIDE ASSEMBLY  
STEEL STRUCTURE  
(Z-GUIDE OR E-GUIDE)

**PRODUCT REVISED**  
as complying with the Florida  
Building Code  
NOA-No. **20-0925.07**  
Expiration Date **07/09/2025**  
By *[Signature]*  
Miami-Dade Product Control

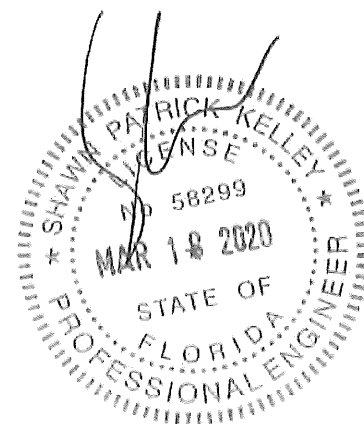

**CORNELL**  
Innovative door solutions.

24 ELMWOOD AVE 1901 S. LITCHFIELD RD  
MOUNTAINTOP, PA GOODYEAR, AZ

P: 800.233.8366  
F: 800.526.0841  
E: ADS@CORNELLIRON.COM

Unless otherwise specified,  
dimensions are in inches &  
tolerances are:

0.000 = +/- 0.031  
FRACTIONAL = +/- 1/32  
ANGLES = +/- 1/2 DEG

TITLE: MIAMI DADE COUNTY APPROVED  
14'-5" WIDE 65 PSF 80 FPS  
NON-INSULATED ROLLING STEEL DOOR

DRAWN BY: TJE  
SIZE: B  
SCALE: AS NOTED  
SHEET: 4/6

DWG NO. ES-16-56-CIW

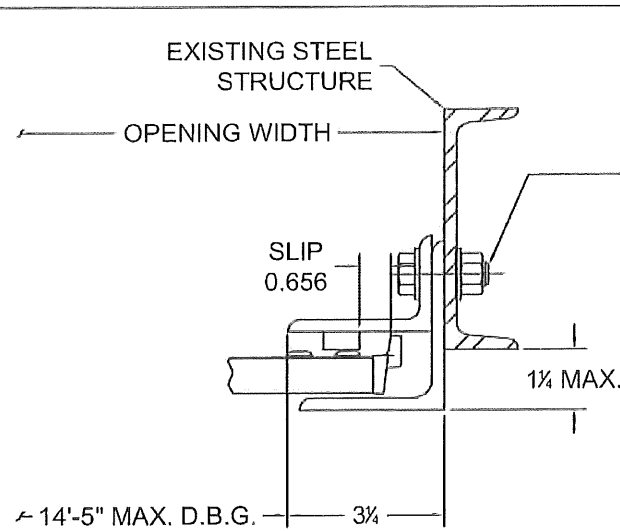

1/2-13 SAE GR. 5, SAE GR. 8, ASTM A325 OR A490 HEX HEAD BOLT, 1/2-13 NUT AND 1/2" HARDENED FLAT WASHERS AT 12" O.C. OR 1/2-13 SAE GR. 5, SAE GR.8, ASTM A325 OR A490 HEX HEAD BOLT AND 1/2" HARDENED FLAT WASHERS AT 12" O.C. TAPPED INTO MIN. NOMINAL 1/4" THICK HSS OR 1/4" THICK STEEL WITH MIN. 36,000 PSI YIELD STRENGTH

12 GUIDE ASSEMBLY STEEL STRUCTURE (BETWEEN JAMBS GUIDE)

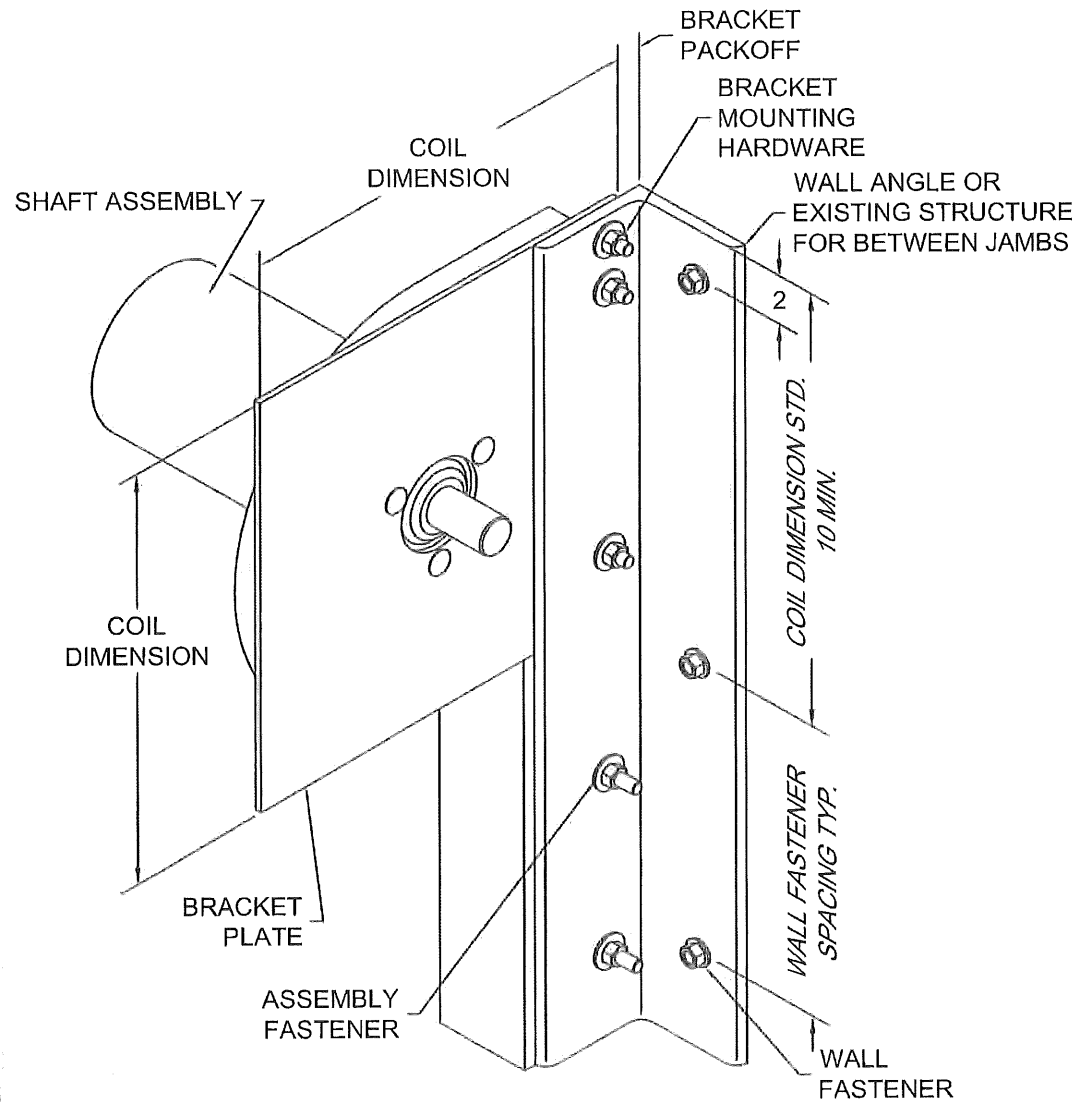

13 BRACKET MOUNTING / TOP WALL ANGLE FASTENING BRACKET MOUNTING PER DETAIL 7 DEPICTED, OTHER BRACKET MOUNTINGS ARE AVAILABLE SCALE: NTS

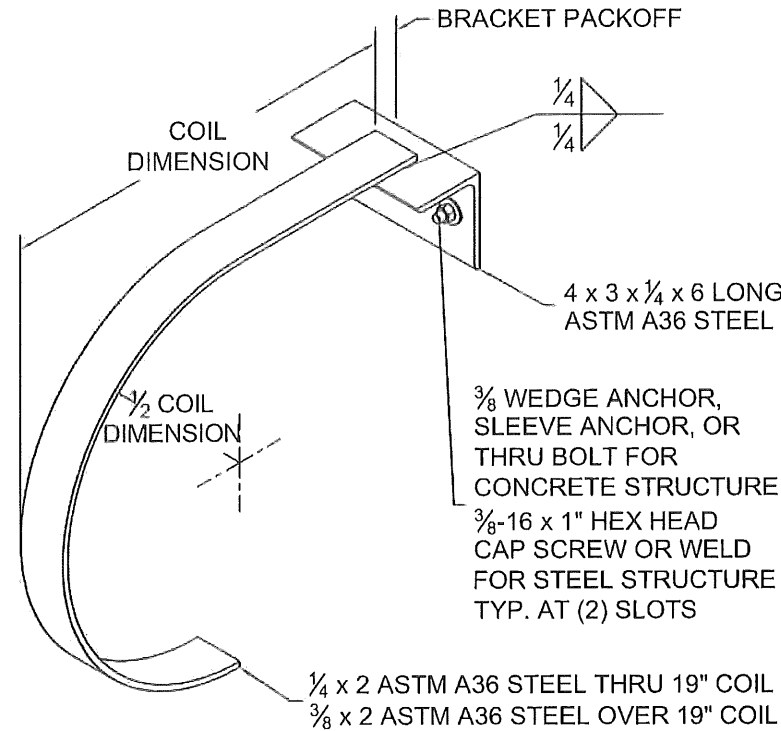

14 MID-HOOD SUPPORT (WHEN REQUIRED) "D" SHAPE DEPICTED, SQUARE STYLE ALSO AVAILABLE SCALE: NTS

L'TR	REVISION	DATE	BY	E.C.O.
*	ORIGINAL ISSUE	09/10/2014	TJE	1614
A	REVISED NOTES	03/27/2015	TJE	1614
B	REVISED TITLE BLOCK; HOOD SUPPORT UPDATE	01/23/2020	MAN	2026

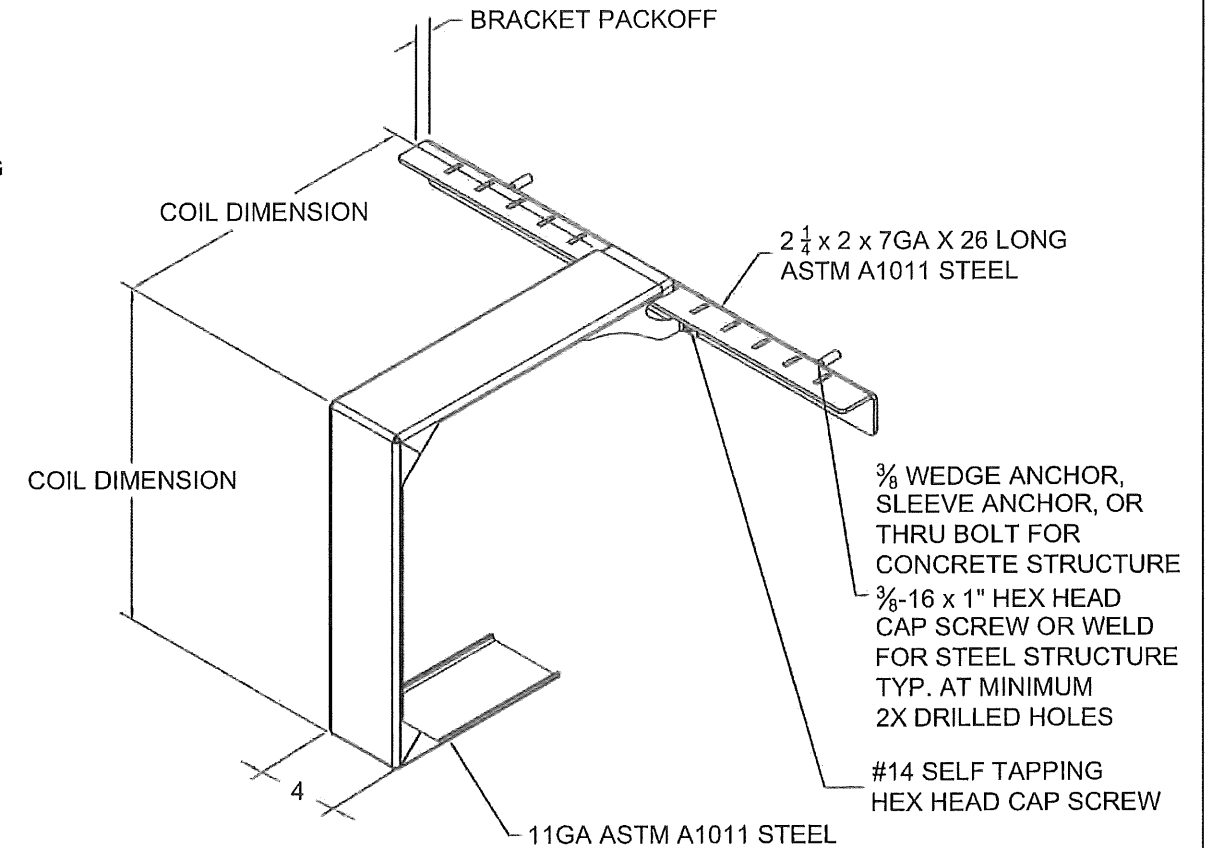

15 MID-HOOD SUPPORT (WHEN REQUIRED) SQUARE STYLE DEPICTED, "D" SHAPE ALSO AVAILABLE SCALE: NTS

**PRODUCT REVISED**  
as complying with the Florida Building Code  
NOA-No. **20-0925.07**  
Expiration Date **07/09/2025**  
By *[Signature]*  
Miami-Dade Product Control



	24 ELMWOOD AVE 1901 S. LITCHFIELD RD MOUNTAINTOP, PA GOODYEAR, AZ	Unless otherwise specified, dimensions are in inches & tolerances are:  0.000 = +/- 0.031 FRACTIONAL = +/- 1/32 ANGLES = +/- 1/2 DEG
	P: 800.233.8366 F: 800.526.0841 E: ADS@CORNELLIRON.COM	
TITLE: MIAMI DADE COUNTY APPROVED 14'-5" WIDE 65 PSF 80 FPS NON-INSULATED ROLLING STEEL DOOR		DRAWN BY: TJE DWG NO: ES-16-56-CIW
	SIZE: B SCALE: AS NOTED SHEET: 5/6	



L'TR	REVISION	DATE	BY	E.C.O.
*	ORIGINAL ISSUE	09/10/2014	TJE	1614
A	REVISED NOTES	03/27/2015	TJE	1614
B	REVISED TITLE BLOCK; HOOD SUPPORT UPDATE	01/23/2020	MAN	2026

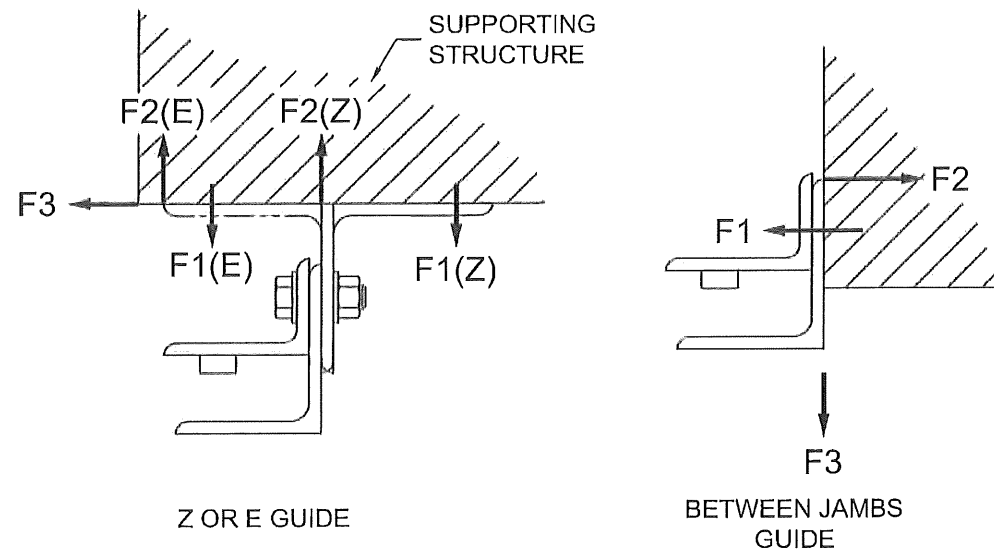

UNREDUCED WIND FORCES ON BUILDING STRUCTURE (LBS / FOOT OF HEIGHT)					
Z-GUIDE					
POSITIVE			NEGATIVE		
F1	F2	F3	F1	F2	F3
1986	1508	1913	3156	3634	1913
E-GUIDE					
POSITIVE			NEGATIVE		
F1	F2	F3	F1	F2	F3
6517	6039	1913	6338	6816	1913
BETWEEN JAMBS GUIDE					
POSITIVE			NEGATIVE		
F1	F2	F3	F1	F2	F3
3745	1832	478	8004	6091	478

**BUILDING DESIGNER NOTE:**  
STRUCTURE MUST BE DESIGNED TO SUPPORT F1, F2, AND F3 FORCES (LBS./FT. OF OPENING HEIGHT) AT EACH JAMB.

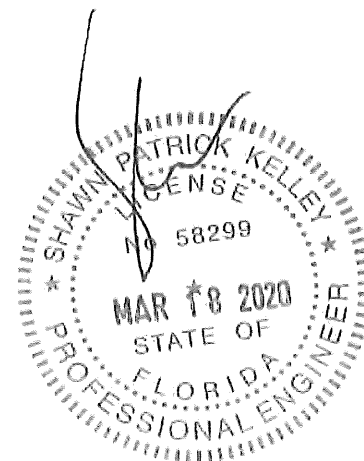

**PRODUCT REVISED**  
as complying with the Florida Building Code  
NOA-No. **20-0925.07**  
Expiration Date **07/09/2025**  
By *[Signature]*  
Miami-Dade Product Control

	24 ELMWOOD AVE 1901 S. LITCHFIELD RD MOUNTAINTOP, PA GOODYEAR, AZ  P: 800.233.8366 F: 800.526.0841 E: ADS@CORNELLIRON.COM	Unless otherwise specified, dimensions are in inches & tolerances are:  0.000 = +/- 0.031 FRACTIONAL = +/- 1/32 ANGLES = +/- 1/2 DEG			
	<b>TITLE:</b> MIAMI DADE COUNTY APPROVED 14'-5" WIDE 65 PSF 80 FPS NON-INSULATED ROLLING STEEL DOOR	<b>DRAWN BY:</b> TJE	<b>SIZE:</b> B	<b>SCALE:</b> AS NOTED	<b>SHEET:</b> 6/6
<b>DWG NO:</b> ES-16-56-CIW					