

ACTION MEMORANDUM

TO: Bibb County Board of Education

FROM: Elaine Wilson, Director of Procurement
David Gowan, Director of Risk Management

SUBJECT: Purchase of Temperature Screening Kiosks

Summary

The Operations Department is seeking to issue a purchase order for temperature screening kiosks for the Fiscal Year 2020-2021 utilizing COVID-19 funds.

Background

The Operations Department in conjunction with the Procurement Department is seeking approval to purchase 75 temperature screening kiosks from Audio Engineering.

The Procurement Department released a RFQ for temperature screening kiosks on July 15, 2020. The Sealed Quote closed on July 20, 2020 and there were 13 respondents. The recommendation is based off the compatibility with the current district network communication system as well as the storage capacity that is needed here at the district. The quote received from Audio Engineering has each system priced at \$1,950.00 per unit.

Bid Submitted by:	Price Per Unit (based on 75 unit purchase)	Other Fees	Fee Description	Total w/Deliver to Various Locations	Total w/Delivery Fee to One Location
Eyemetric	3,990.00	995	(onsite delivery install)	381,000.00	381,000.00
		95	(RICHTECH Wifi Bridge)		
ActNow	1,989.00	1,785.45	(security software)	170,962.20	170,962.20
		266.69	(mounting pole)		
Convergent				228,049.00	220,169.00
Howard Technology (Opt 1)	8,107.00	540	(installation)	648,525.00	648,525.00
(Opt 2)	2,000.00	4,425 + 5,963.00	(shipping + install)	160,388.00	160,388.00
Broadband Telecom	10,778.40	6,552.00	(3 yr. svc/maint)	1,359,780.00	1,304,780.00
GCR	4,500.00			337,500.00	337,500.00
SAI Medical, Inc.	2,750.00	500	(shipping)	206,750.00	206,750.00
BioLogistex, Inc.	1,920.00	(Adult Size Stand)		144,000.00	144,000.00
	1,820.00	(Child/Handicap Size Stand)		136,500.00	136,500.00

August 4, 2020

	1,720.00	(Wall Mount)		129,000.00	129,000.00
SafeStations	31,000.00	400	(delivery)	2,355,000.00	2,355,000.00
Audio Engineering	1,950.00	375	(installation)	174,375.00	174,375.00
Fouraker Electronics	895	160	(adjustable stand)	79,125.00	79,125.00
SupplyCore	2,044.32			153,324.00	153,324.00
NMS Imaging	5,299.00	18,750.00	(shipping)	416,175.00	416,175.00

Recommendation

It is recommended the Bibb County Board of Education authorize the Superintendent to issue a purchase order to Audio Engineering for the one time purchase of 75 temperature screening kiosks in the amount not to exceed \$174,375.00.

Superintendent's Comments and Approval

<u>Superintendent's Comments</u>	
Dr. Curtis L. Jones, Jr.	Approved

APPENDIX I

BID TABULATION PAGE

THE QUANTITIES SHOWN IN THIS BID DOCUMENT ARE ESTIMATES. ACTUAL QUANTITIES PURCHASED MAY VARY.

Product Info	Product Specification	Delivery Fee to Various Locations	Delivery Fee to ONE location
75 EACH DS-K1T671TM-3XF	Temperature Screening Terminal, access control device integrated with HAT (High Accuracy Temperature/ EST(Elevated Skin Temperature) screening.	\$1,950.00 each unit	\$1,950.00 each unit
75 EACH KAB6-BASE	Floor Stand Base	Included in price above	Included in price above
75 EACH KAB671-B	Floor Stand	Included in price above	Included in price above
1 HIKCENTRAL-ACS-BASE	Software/License for 16 Terminals	Included in price above	Included in price above
59 HIKCENTRAL-ACS	Software/License for 59 Terminals	Included in price above	Included in price above
LABOR Warranty	Installation if needed, Audio Engineering has been a Hikvision Dealer Partner since January 2015. As a Hikvision Platinum Dealer Partner, we receive full support and an additional 2 years warranty from Hikvision on most products for a total of 5 years and will extend this warranty to BCSC with the exception of abuse and or Acts of God for manufacture warranty and or repair. Audio Engineering will be responsible for sending the product back to the manufacture.	\$375.00 per unit	\$375.00 per unit

DS-K1T671TM-3XF Temperature Screening Terminal¹

Hikvision's DS-K1T671TM-3XF terminal is an access control device integrated with **HAT (High Accuracy Temperature)/EST (Elevated Skin Temperature)** screening. It can quickly measure skin-surface temperature and notify the user about abnormal readings. This product is perfect for many applications, including office buildings, transportation hubs, retail facilities, education centers, and many others.



Available Model: DS-K1T671TM-3XF

- Vanadium Oxide Uncooled Sensor Measures Target's Temperature
- Range: 86° to 113° F (30° to 45° C), Accuracy: $\pm 0.5^{\circ}$ C w/o Black Body Calibration
- Recognition Distance: 0.3 m to 2 m
- Fast Temp. Measurement Mode: Detects Face, Takes Skin-Surface Temp. w/o Identity Authentication
- Multiple Authentication Modes: Card/Temperature, Face/Temperature, Card/Face/Temperature, etc.
- Face Mask Detection: If Maskless Face Detected, Voice Reminder Prompt Sounds
 - Face Mask Alert: Authentication or Attendance Is Valid
 - Forced Mask Wearing Alert: Authentication or Attendance Fails
- Displays Temperature Measurement Results on Authentication Page
- Triggers Voice Prompt when Detecting Abnormal Temperature
- Configurable Door Status (Open/Close) when Detecting Abnormal Temperature
- Transmits Online and Offline Temperature Information to Client Software via TCP/IP Communication and Saves Data on Client Software
- Face Recognition Duration <0.2 s/User; Face Recognition Accuracy Rate $\geq 99\%$
- 50,000 Face Capacity, 50,000 Card Capacity, and 100,000 Event Capacity
- Suggested Height for Face Recognition: Between 1.4 m and 1.9 m
- Attendance Status: Check In, Check Out, Break In, Break Out, Overtime In, Overtime Out
- Watchdog Design and Tamper Function
- Audio Prompt for Authentication Result
- NTP, Manual Time Synchronization, and Auto Synchronization
- Connects to External Access Controller or Wiegand Card Reader via Wiegand Protocol
- Connects To Secure Door Control Unit via RS-485 Protocol To Avoid Door Opening if Terminal Destroyed
- Imports and Export Data to the Device from the Client Software

¹U.S.

Disclaimer: Hikvision USA Inc. products depicted herein are not FDA approved medical devices and are not intended for use in the diagnosis of disease or other conditions, or in the cure, mitigation, treatment, or prevention of disease. When configured correctly, the Hikvision products discussed herein can identify elevated human skin-surface temperature relative to a sample population.

Canada

Disclaimer: Hikvision's Thermographic Cameras are designed for immediate detection and preliminary screening of elevated skin-surface temperature in high-traffic areas. When measuring core body temperature, please verify through the use of clinical measurement devices and/or by consulting a medical professional. Hikvision's Thermographic Cameras must be used in accordance with local laws and regulations.

Notes

Biometric recognition products are not 100% applicable to anti-spoofing environments. If you require a higher security level, use multiple authentication modes.

In order to get an accurate temperature reading, wait 90 minutes for the device to warm up after the device is powered on.

Specifications

Model		DS-K1T671TM-3XF
Operating System		Linux
Temperature Measurement	Sensor	Vanadium oxide uncooled sensor
	Resolution	120 × 160
	Frame Rate	25 fps
	Temperature Range	86° to 113° F (30° to 45° C)
	Temperature Accuracy	±0.9° F (±0.5° C) without black body calibration
	Measuring Distance	0.98 ft to 6.5 ft (0.3 m to 2 m)
Screen	Screen	7 inch touch screen
	Ratio	16:9
	Resolution	1024 × 600
Camera		2 MP dual-lens camera, WDR
Indicator		Supported
Face	Recognition Mode	Face: 1:1 and 1:N
	Face Capacity	50,000
	Face Recognition Duration	<0.2 s per person
	Face Recognition Distance	0.98 ft to 6.5 ft (0.3 m to 2 m)
Card	Card Capacity	50,000
	Card Type	M1 card
	Card Presenting Duration	<1 s
	Card Presenting Distance	0" to 1.97" (0 cm to 5 cm)
Event Capacity		100,000
Interface		Network × 1, RS-485 × 1, Wiegand × 1, USB × 2, alarm output × 1, alarm input × 2, lock × 1, door contact × 1, exit button × 1, tamper × 1
Network		10/100/1000 Mbps self-adaptive
Tamper		Supported
Other	Working Voltage	12 VDC/2 A
		Power supply (DS-KP12V-3A): not included
	Working Temperature	32° to 122° F (0° to 50° C)
		For temperature measurement: 50° to 95° F (10° to 35° C)
	Working Humidity	10% to 90% (non-condensing)
	Application	Indoor
Application Environment	Indoor and windless environment use only	
Brackets		Wall mount (included)
		Floor Stand (DS-KAB671-B): not included
		Desk Stand (DS-DM0701BL): not included

* **WARNING:** Do not expose the equipment to direct sunlight, low ventilation, or a heat source such as a heater or radiator (ignoring this warning can cause fire danger).

Dimensions

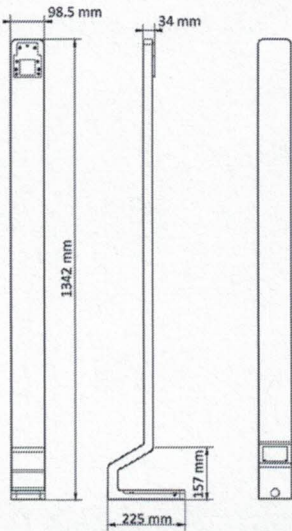
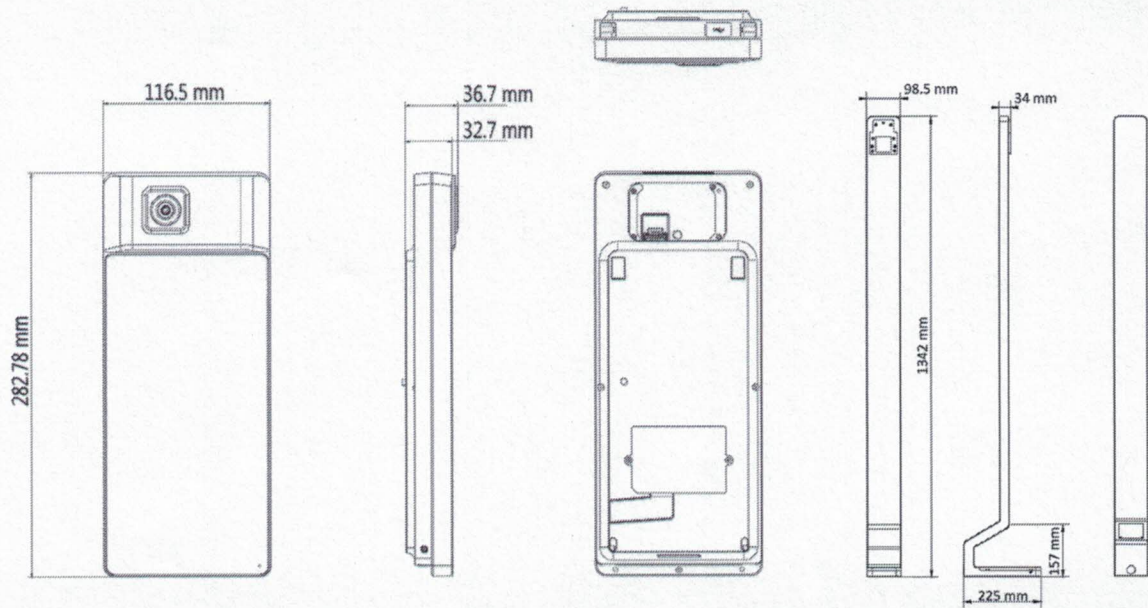

Floor Stand, DS-KAB671-B
(Not Included)

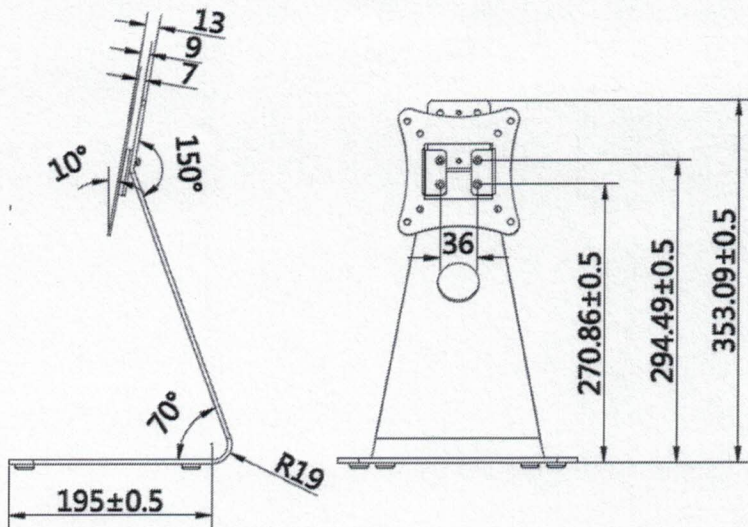

Desk Stand, DS-DM0701BL
(Not Included)

DS-KAB671-B Floor Stand



Dimensions

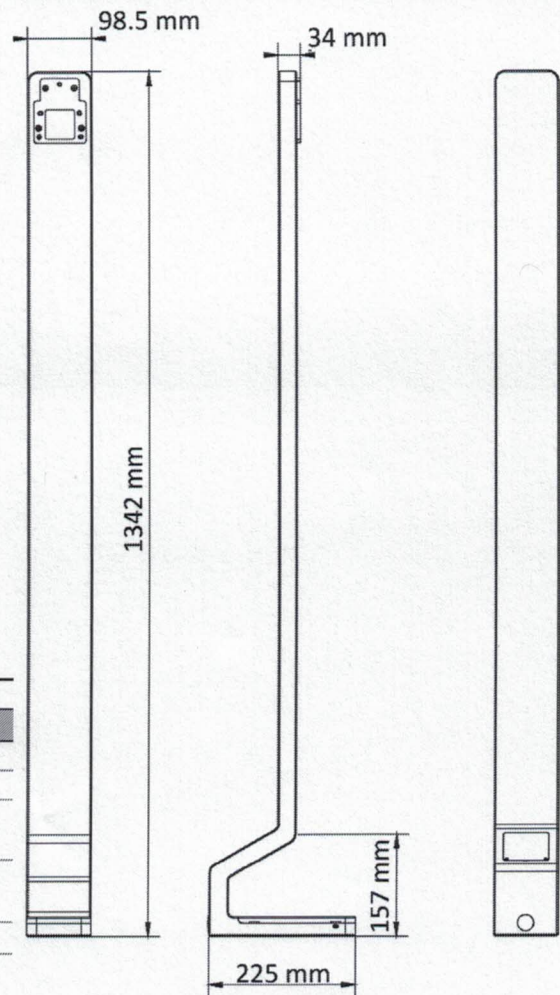

Specifications

DS-KAB671-B	
Material	SPCC
Weight	6.7 kg (14.8 lb)
Dimensions (w × h × d)	98.5 mm × 1342 mm × 225 mm (3.9" × 52.8" × 8.9")
Compatibility	DS-K1T671M, DS-K1T671MF, DS-K1T671TM-3XF
Base	DS-KAB6-Base (not included)

Available Models: DS-KAB671-B

DS-KAB6-BASE Floor Stand Base



- The base is applicable to the DS-KAB671-B floor stand

▪ Specification

Others	
Material	SPHC (Hot rolled steel plate)
Working temperature	-30 °C to 60 °C (-22 °F to 140 °F)
Dimensions	325 mm × 325 mm × 17 mm (12.8" × 12.8" × 0.7")
Weight	4863.5 g (10.7 lb)

▪ Dimension

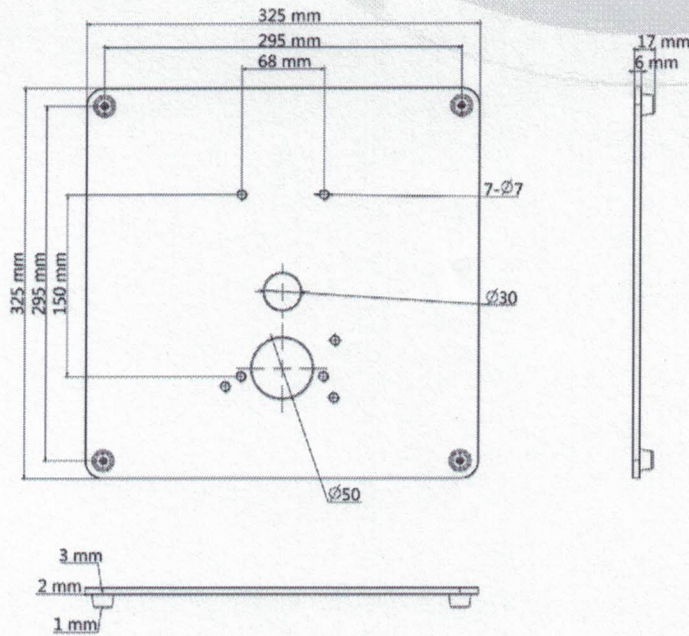

▪ Available Model

DS-KAB6-BASE





Distributed by



HIKVISION

Headquarters

No.555 Qianmo Road, Binjiang District,
Hangzhou 310051, China
T +86-571-8807-5998
overseasbusiness@hikvision.com

Hikvision USA
T +1-909-895-0400
sales.usa@hikvision.com

Hikvision Australia
T +61-2-8599-4233
salesau@hikvision.com

Hikvision India
T +91-22-28469900
sales@pramahikvision.com

Hikvision Canada
T +1-866-200-6690
sales.canada@hikvision.com

Hikvision Thailand
T +662-275-9949
sales.thailand@hikvision.com

Hikvision Europe
T +31-23-5542770
sales.eu@hikvision.com

Hikvision Italy
T +39-0439-6902
info.it@hikvision.com

Hikvision Brazil
T +55 11 3318-0050
Latam.support@hikvision.com

Hikvision Turkey
T +90 [216]521 7070- 7074
sales.tr@hikvision.com

Hikvision Malaysia
T +601-7652-2413
sales.my@hikvision.com

Hikvision UK & Ireland
T +01628-902140
sales.uk@hikvision.com

Hikvision South Africa
Tel: +27 [10] 0351172
sele.africa@hikvision.com

Hikvision France
T +33[0]1-85-330-450
info.fr@hikvision.com

Hikvision Kazakhstan
T +7-727-9730667
nikia.panflov@hikvision.ru

Hikvision Vietnam
T +84-974270868
sales.vi@hikvision.com

Hikvision UAE
T +971-4-4432090
salesme@hikvision.com

Hikvision Singapore
T +65-6684-4718
sg@hikvision.com

Hikvision Spain
T +34-91-737-16-55
info.es@hikvision.com

Hikvision Tashkent
T +99-87-1238-9438
uzb@hikvision.ru

Hikvision Hong Kong
T +852-2151-1761
Info.hk@hikvision.com

Hikvision Russia
T +7-495-669-67-99
saleru@hikvision.com

Hikvision Korea
T +82-[0]31-731-8817
sales.korea@hikvision.com

Hikvision Poland
T +48-22-460-01-50
info.pl@hikvision.com

Hikvision Indonesia
T +62-21-2933759
Sales.Indonesia@hikvision.com

Hikvision Colombia
sales.colombia@hikvision.com

October 29, 2019

Attn:
Bibb County Board of Education
4580 Cavalier Drive
Macon, GA 31211

Re: Audio Engineering Partnership

To Whom It May Concern,

We hereby certify that the following company

**Audio Engineering
3088 Napier Avenue
Macon, GA 31204**

is an official Platinum Dealer Partner, of Hikvision in North America, is authorized to resell solution software, hardware and services, and is entitled to receive commercial and technical support from Hikvision as well as have access to necessary technical documentation. Audio Engineering has been a Hikvision Dealer Partner since January, 2015.

As a Hikvision Platinum Dealer Partner, we hereby confirm that we will provide Audio Engineering, our full support for projects or business developments involving our solutions and/or products, and specifically the sales and services activities related to security solutions, allowing Audio Engineering to promote our solutions.

In addition to dedicated support from Hikvision, as a Hikvision Platinum Dealer Partner, Audio Engineering receives an additional 2 year warranty on most Hikvision products for a total 5 year warranty.

This authorization is valid until further written notice from Hikvision.

Sincerely,



Scott Stone
Director of Sales, Southeast US
Hikvision USA

APPENDIX II
OFFEROR AFFIRMATION FORM:

Company Name: JOE H. PINKERTON, JR. D/B/A AUDIO ENGINEERING

IFB Name: TEMPERATURE KIOSK

IFB Number: 20-27

After careful examination of the solicitation document in its entirety, 20-27 and any addendum(s) issued, the undersigned proposes to satisfy all requirements in accordance with said documents.

For Consideration of this proposal, the undersigned hereby affirms that:

1. He/She is a duly authorized official of the offeror.
2. NO changes were made to the original IFB document,
3. The proposal is being submitted on behalf of the offeror in accordance with any terms and conditions set forth in this document.
4. The offeror will accept any awards made to it as a result of the proposal submitted here in for a minimum of one hundred and twenty (120) days following the date of submission.
5. The offeror will accept the terms and conditions set forth in the contract template attached here to.

If notified in writing by mail or delivery of the acceptance of the award, the undersigned agrees to furnish and deliver to the assigned procurement professional within five (5) days of the request, a certification of insurance indicating the coverage specified within this solicitation.

A contract shall be established which will set forth the terms of this agreement. The contract shall be interpreted, constructed, and give effect in all respects according to the laws of the State of Georgia.

Nondiscrimination in Employment: We, the supplier of goods, materials, equipment and services covered by this bid or contract, have not discriminated in the employment, in any way, against any person or person, or refused to continue the employment of any person or persons on account of their race, color, sex, religion, national origin, marital status, sexual orientation, age, or disability.

Respectfully Submitted,

Company Name

JOE H. PINKERTON, JR D/B/A AUDIO ENGINEERING

Authorized Official Name

JOE H. PINKERTON, JR.

Signature

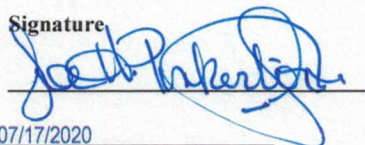

Title: OWNER

Date: 07/17/2020

E-mail Address: joe@audioeng.net cc ranae@audioeng.net

The legal name of the bidder is: JOE H. PINKERTON, JR. D/B/ AUDIO ENGINEERING



APPENDIX III

Non-Collusion Affidavit

(Form must be completed and returned with bid.)

Bibb County Board of Education, Macon, GA 31201

I state that I am OWNER of AUDIO ENGINEERING

Title

Name of Company

And that I am authorized to make this affidavit on behalf of my firm, and its owners, directors, and officers. I am the person responsible in my firm for the price(s) and the amount of this bid and I state that this bid is made in good faith.

I state that:

1. The price(s) and amounts of this bid have been arrived at independently and without consultation, communication or agreement with any other contractor, bidder, or potential bidder; neither the approximate price(s) have been disclosed nor will they be disclosed before bid opening to any other contractor, bidder or potential bidder.
2. No attempt has been made or will be made to induce any firm or person to refrain from bidding on this contract, or to submit a bid higher than this bid, or to submit any intentionally high or noncompetitive bid or other form of complimentary bid.

JOE H. PINKERTON, JR. D/B/A AUDIO ENGINEERING, its affiliates, subsidiaries, officers,

Name of Company

Directors and employees are not currently under investigation by any government agency and have not in the last three years been convicted or found liable for any act prohibited by State or Federal law in any jurisdiction, involving conspiracy or collusion with respect to bidding on any public contract.

I understand and my firm understands that any misstatement in this affidavit is and shall be treated as fraudulent concealment from the Bibb County Board of Education of the true facts relating to submission of bids for this contract.

JOE H. PINKERTON, JR. 07/17/2020

OWNER

Name/Date

Title or Position

Signature

APPENDIX IIII
OFFEROR'S CHECKLIST

PROPOSAL NO.: IFB20-27 TEMPERATURE KIOSK

- The proposal has been signed by an authorized principal or authorized official of the firm.
- No conditions, restrictions or qualifications have been placed by the company on this proposal that would have the proposal declared non-responsive.
- We are prepared to provide the insurance required in this solicitation.
- All forms
- E-verify Affidavit

JOE H. PINKERTON, JR. D/B/A AUDIO ENGINEERING
COMPANY NAME

JOE H. PINKERTON, JR.
TYPE OR PRINT NAME OF PERSON COMPLETING CHECKLIST

SIGNATURE OF PERSON COMPLETING CHECKLIST

JULY 17, 2020
DATE

58-0687037
COMPANY FEDERAL ID NUMBER

joe@audioeng.net cc ranae@audioeng.net
COMPANY E-MAIL ADDRESS

READ AND COMPLETE THIS CHECKLIST BEFORE SUBMITTING THE PROPOSAL

RETURN WITH PROPOSAL



APPENDIX V

Certificate Regarding Debarment, Suspension, Ineligibility

(Form must be completed and returned with bid.)

The Bibb County School District is a recipient of Federal monies. As such we require that participating vendors not be debarred, suspended, ineligible or excluded from doing business with the Federal government or any agency thereof.

The prospective participant certifies, by submission of the bid, that neither it, nor its principals, is presently debarred, suspended, proposed for debarment, declared ineligible, or excluded from participation in this transaction by any Federal department or agency.

JOE H. PINKERTON, JR. D/B/A AUDIO ENGINEERING

Organization Name

JOE H. PINKERTON, JR. OWNER

Name(s) and Title(s) of Authorized Representative(s)

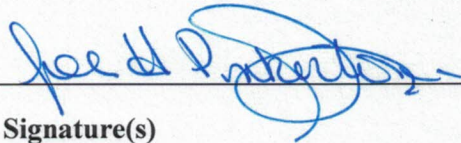

Signature(s)

07/17/2020

Date

APPENDIX VII

Vendor Affidavit under O.C.G.A. § 13-10-91(b)(1)

By executing this affidavit, the undersigned Vendor verifies its compliance with O.C.G.A. § 13-10-91, stating affirmatively that the individual, firm or corporation which is engaged in the physical performance of services on behalf of Bibb County School District has registered with, is authorized to use and uses the federal work authorization program commonly known as E-Verify, or any subsequent replacement program, in accordance with the applicable provisions and deadlines established in O.C.G.A. § 13-10-91. Furthermore, the undersigned Vendor will continue to use the federal work authorization program throughout the contract period and the undersigned Vendor will contract for services in satisfaction of such contract only with sub Vendors who present an affidavit to the Vendor with the information required by O.C.G.A. § 13-10-91(b). Vendor hereby attests that its federal work authorization user identification number and date of authorization are as follows:

431979

JULY 14, 2011

Federal Work Authorization User Identification Number

Date of Authorization

JOE H. PINKERTON, JR. D/B/A AUDIO ENGINEERING

(TEMPERATURE KIOSK)

Name of Vendor

Name of Project

Bibb County School District

Name of Public Employer

I hereby declare under penalty of perjury that the foregoing is true and correct.

Executed on JULY , 17, 2012 in MACON (city), GA (state).

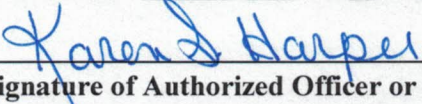
Signature of Authorized Officer or Agent

KAREN S. HARPER Secretary Treasurer

Printed Name and Title of Authorized Officer or Agent

SUBSCRIBED AND SWORN BEFORE ME ON THIS THE 17th DAY OF July, 2012

NOTARY PUBLIC

My Commission Expires: February 19, 2022

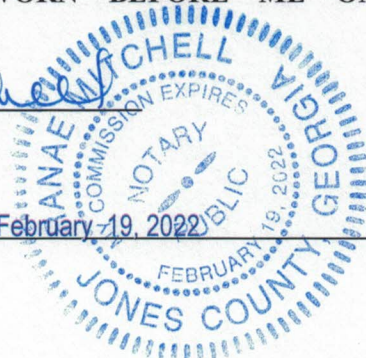

Company ID Number: 431979

North American Industry Classification Systems Code:	238
Administrator:	
Number of Employees:	5 to 9
Number of Sites Verified for:	1
Are you verifying for more than 1 site? If yes, please provide the number of sites verified for in each State:	
• GEORGIA 1 site(s)	

Information relating to the Program Administrator(s) for your Company on policy questions or operational problems:

Name:	Donna R Mitchell	Fax Number:	(478) 743 - 5957
Telephone Number:	(478) 746 - 6193		
E-mail Address:	danae@audioeng.mga.com New danae@audioeng.net		
Name:	Karen S Harper	Fax Number:	(478) 743 - 5957
Telephone Number:	(478) 746 - 6193		
E-mail Address:	karcnh@audioeng.mga.com New Karen@audioeng.net		

ANNUAL RENEWAL DEADLINE: APRIL 1ST

**MACON-BIBB COUNTY
BUSINESS LICENSE
OCCUPATIONAL TAX CERTIFICATE**
200 CHERRY STREET, SUITE 202
MACON, GA 31201

AUDIO ENGINEERING

LICENSE # 910
P&Z #
BUSINESS NAME: **AUDIO ENGINEERING**
BUSINESS ADDRESS: 3088 NAPIER AVE
MACON GA 31204
HOME/COMMERCIAL: Commercial
BUSINESS DESCRIPTION:

1 Administrative
8 Number of Employees

1. Your Occupational Tax **MUST** be paid on or before April 1st of each year. Occupational Tax Certificate renewals are the responsibility of the business owner and shall occur each year during the 90-day period prior to April 1st. Renewal reminder letters are provided as a courtesy and are not required for renewal purposes.
2. This certificate **MUST BE DISPLAYED** in a conspicuous place inside the above business location.
3. Macon-Bibb County **MUST** be notified of any changes in ownership, location, business name or business closure. This certificate is not transferable and is only valid for the above location.

**THE BUSINESS LISTED ABOVE IS REGISTERED WITH MACON-BIBB COUNTY
FOR THE YEAR OF 1/1/2020 TO 12/31/2020**

AUDIO ENGINEERING
P.O. BOX 2405
MACON GA 31203





STATE OF GEORGIA
BRAD RAFFENSPERGER, Secretary of State
Georgia Construction Industry Licensing Board
LICENSE NO. LVU001539

Joe H Pinkerton, Jr

P O BOX 2405
MACON GA 31203-2405

Low Voltage-Unrestricted

EXP DATE - 08/31/2021 Status: Active
Issue Date: 04/30/1985

A pocket-sized license card is below. Above is an enlarged copy of your pocket card.

Please make note of the expiration date on your license. It is your responsibility to renew your license before it expires. Please notify the Board if you have a change of address.

Wall certificates suitable for framing are available at cost, see board fee schedule. To order a wall certificate, please order from the web site – www.sos.state.ga.us/plb.

Please refer to Board Rules for any continuing education requirements your profession may require.

Georgia State Board of Professional Licensing
237 Coliseum Drive
Macon GA 31217
Phone: (844) 753-7825
www.sos.state.ga.us/plb

Joe H Pinkerton, Jr
3088 Napier Avenue
Macon GA 31204



STATE OF GEORGIA
BRAD RAFFENSPERGER, Secretary of State
Georgia Construction Industry Licensing Board
License No. LVU001539

Joe H Pinkerton, Jr

P O BOX 2405
MACON GA 31203-2405

Low Voltage-Unrestricted

EXP DATE - 08/31/2021 Status: Active
Issue Date: 04/30/1985

Request for Taxpayer Identification Number and Certification

Give Form to the requester. Do not send to the IRS.

▶ Go to www.irs.gov/FormW9 for instructions and the latest information.

Print or type.
See Specific Instructions on page 3.

	1 Name (as shown on your income tax return). Name is required on this line; do not leave this line blank. JOSEPH H. PINKERTON, JR. D/B/A	
	2 Business name/disregarded entity name, if different from above AUDIO ENGINEERING	
	3 Check appropriate box for federal tax classification of the person whose name is entered on line 1. Check only one of the following seven boxes. <input checked="" type="checkbox"/> Individual/sole proprietor or single-member LLC <input type="checkbox"/> C Corporation <input type="checkbox"/> S Corporation <input type="checkbox"/> Partnership <input type="checkbox"/> Trust/estate <input type="checkbox"/> Limited liability company. Enter the tax classification (C=C corporation, S=S corporation, P=Partnership) ▶ _____ Note: Check the appropriate box in the line above for the tax classification of the single-member owner. Do not check LLC if the LLC is classified as a single-member LLC that is disregarded from the owner unless the owner of the LLC is another LLC that is not disregarded from the owner for U.S. federal tax purposes. Otherwise, a single-member LLC that is disregarded from the owner should check the appropriate box for the tax classification of its owner. <input type="checkbox"/> Other (see instructions) ▶ _____	4 Exemptions (codes apply only to certain entities, not individuals; see instructions on page 3): Exempt payee code (if any) _____ Exemption from FATCA reporting code (if any) _____ (Applies to accounts maintained outside the U.S.)
	5 Address (number, street, and apt. or suite no.) See instructions. 3088 NAPIER AVE (SHIPPING) PO BOX 2405 (MAILING)	Requester's name and address (optional) BIBB COUNTY SCHOOL DISTRICT DEPARTMENT OF PROCUREMENT VENDOR REGISTRATION WWW.BCSDK12.NET
	6 City, state, and ZIP code MACON, GA. 31204 (SHIPPING) MACON, GA. 31203 (MAILING)	
	7 List account number(s) here (optional)	

Part I Taxpayer Identification Number (TIN)

Enter your TIN in the appropriate box. The TIN provided must match the name given on line 1 to avoid backup withholding. For individuals, this is generally your social security number (SSN). However, for a resident alien, sole proprietor, or disregarded entity, see the instructions for Part I, later. For other entities, it is your employer identification number (EIN). If you do not have a number, see *How to get a TIN*, later.

Note: If the account is in more than one name, see the instructions for line 1. Also see *What Name and Number To Give the Requester* for guidelines on whose number to enter.

Social security number	
[] [] [] - [] [] - [] [] [] []	
or	
Employer identification number	
5 8 - 0 6 8 7 0 3 7	

Part II Certification

Under penalties of perjury, I certify that:

1. The number shown on this form is my correct taxpayer identification number (or I am waiting for a number to be issued to me); and
2. I am not subject to backup withholding because: (a) I am exempt from backup withholding, or (b) I have not been notified by the Internal Revenue Service (IRS) that I am subject to backup withholding as a result of a failure to report all interest or dividends, or (c) the IRS has notified me that I am no longer subject to backup withholding; and
3. I am a U.S. citizen or other U.S. person (defined below); and
4. The FATCA code(s) entered on this form (if any) indicating that I am exempt from FATCA reporting is correct.

Certification instructions. You must cross out item 2 above if you have been notified by the IRS that you are currently subject to backup withholding because you have failed to report all interest and dividends on your tax return. For real estate transactions, item 2 does not apply. For mortgage interest paid, acquisition or abandonment of secured property, cancellation of debt, contributions to an individual retirement arrangement (IRA), and generally, payments other than interest and dividends, you are not required to sign the certification, but you must provide your correct TIN. See the instructions for Part II, later.

Sign Here

Signature of U.S. person ▶

Joe H. Pinkerton, Jr.

Date ▶ 07/16/2020

General Instructions

Section references are to the Internal Revenue Code unless otherwise noted.

Future developments. For the latest information about developments related to Form W-9 and its instructions, such as legislation enacted after they were published, go to www.irs.gov/FormW9.

Purpose of Form

An individual or entity (Form W-9 requester) who is required to file an information return with the IRS must obtain your correct taxpayer identification number (TIN) which may be your social security number (SSN), individual taxpayer identification number (ITIN), adoption taxpayer identification number (ATIN), or employer identification number (EIN), to report on an information return the amount paid to you, or other amount reportable on an information return. Examples of information returns include, but are not limited to, the following.

- Form 1099-INT (interest earned or paid)

- Form 1099-DIV (dividends, including those from stocks or mutual funds)
- Form 1099-MISC (various types of income, prizes, awards, or gross proceeds)
- Form 1099-B (stock or mutual fund sales and certain other transactions by brokers)
- Form 1099-S (proceeds from real estate transactions)
- Form 1099-K (merchant card and third party network transactions)
- Form 1098 (home mortgage interest), 1098-E (student loan interest), 1098-T (tuition)
- Form 1099-C (canceled debt)
- Form 1099-A (acquisition or abandonment of secured property)

Use Form W-9 only if you are a U.S. person (including a resident alien), to provide your correct TIN.

If you do not return Form W-9 to the requester with a TIN, you might be subject to backup withholding. See What is backup withholding, later.



Ladies and Gentlemen:

The Bibb County School District takes this opportunity to announce that we are requesting bids for Temperature Screening Kiosks

. All bids should be delivered to the Bibb County School District Purchasing Department via portal of Vendor Registry.

Bids will be accepted prior to **July 20th, 2020 at 11 am EST** which time they will open and reviewed by the Procurement Office.

All bids will be evaluated as described in the attached document time is of the essence and any bids received after the announced time and date for submittal whether by mail or otherwise, will be rejected. The time of receipt shall be determined by the time clock stamp in the Purchasing Department.

Late bids received will be so noted in the bid file in order that the vendor's name will not be removed from the subject commodity/service list. Late bids will not be considered.

All Vendors Completing this bid should register online as well, please visit the Bibb County School District website, under Department, Procurement, Vendor Registration.
www.bcsdk12.net.

If you have any questions concerning this bid, please submit them in writing to Elaine M. Wilson, Elaine.wilson@bcsdk12.net. In addition, all communication relating to this bid solicitation, either before or after the bid opens, must be coordinated through the Purchasing Department to Elaine Wilson, via email ONLY; Elaine.Wilson@bcsdk12.net,

Your interest and participation in submitting a bid will be appreciated.

Elaine M. Wilson
Procurement Director

TENTATIVE TIMELINE

IFB BID NUMBER:	IFB 20-27
IFB QUESTION DEADLINE:	07/14/2020
IFB DUE DATE:	07/20/2020 @ 11 AM, EST.
LOCATION AND TIME DUE:	Due online Via Vendor Registry

A. Background:

The Bibb County School District has over 25,000 students along with 38 Sites, as well as 25 Departments. We are currently seeking a qualified contractor to provide Temperature Kiosk, for district wide locations.

B. Invitation:

The procurement office, on behalf of the Bibb County School District, would like to extend a formal offer to all-qualified contractors according to the specifications indicated within this RFP. All questions pertaining to this RFB should be emailed to the Procurement Director, Elaine M. Wilson, Elaine.wilson@bcsdk12.net.

Please make sure you put the Bid Number (20-27) is in the subject. All questions and answers will be posted under the purchasing menu, located on the Bibb County Board of Education webpage, under vendor registry (www.vendorregistry.com), under Bibb County School District. All questions and answers will be posted under the Bibb County School District Bid Page (Vendor Registry).

C. SPECIFICATIONS

Purpose and Objective

The purpose and intent of this invitation to bid is to secure single fixed prices and establish a term contract for the purpose of delivery temperature kiosk to various locations throughout the district.

All manufacturing warranties will be disclosed among the purchase, all training will be conducted within a 2-week delivery timeframe.

All deliveries and installation will be completed to ensure all parties are aware of the functionality, and necessary information to ensure the kiosk are working appropriately.

Scope of Work

Provide pricing, training, installation of temperature kiosk for district needs, according to the specifications outlined.

Standard features:

- Free standing, pedestal temperature kiosk
- Temperature and facial recognition software
- Wireless connectivity, built-in sound and light alarms
- Adjustable camera height from 3'5" to 7'0"
- Multi-point temperature measurement
- 8" minimum screen size
- 3' temperature detection distance
- Temperature accuracy +/- 1.0F

- Minimum scan time <2 seconds
- Dustproof & waterproof design
- No touch, no contact surfaces

Optional features:

- Network capabilities
- Multi-tracking capabilities for temperature scans
- Access control capabilities, ID card readers
- Storage capabilities and management options
- Alternative mounting options

Quantities

We are looking for an initial order of 75 machines, they will be delivered to various locations throughout the district. Some of the areas DO not have a lift gate.

Award

This bid may be awarded TO ONE vendor.

Deliveries

Bid prices shall be FOB. Deliveries must be made from 8:00 am to 2:00 pm. All other deliveries must be approved in advance by BCSD warehouse staff. When issued a Purchase Order by BCSD for materials designated as a standard stock item, the vendor must ship the order complete up to the minimum stock quantity within three (3) working days.

All other items should be delivered within seven (7) working days. Vendor shall also notify the BCSD within one (1) business day of receiving the purchase order of any backorders. BCSD reserves the right to cancel backorders and order from other sources. Any failure to comply with the terms and requirements of the bid may result in cancellation of all or part of the award.

We will look at delivering to one location the warehouse if the awardee is able to coordinate the installation for the machines to the various locations.

Evaluation:

The contract, if awarded, will be awarded to the responsible bidder. Product quality, service issues and other factors stipulated above must be met to the satisfaction of the Board for a bid to be considered responsive. Moreover, the Board will award the contract to the next most qualified bidder. Consequently, if the selected bidder is unable to execute a contract and provide delivery within the time parameters specified in this IFB.

D. INTERPRETATION/ADDENDA:

If any questions should arise pertaining to the IFB Documents, the bidders may email the Director of Procurement, Elaine M. Wilson, elaine.wilson@bcsdk12.net, please include the IFB number in

the Subject line, in order to guarantee a response to the question submitted. The questions should be received prior to the deadline within the TENTATIVE TIMELINE.

E. ADDITIONAL INFORMATION:

We have provided documentation to be reviewed for these appraisals we asked that if you have any other questions, or concerns. Please mail the Procurement Office, utilizing the email procurement@bcsdk12.net; please make sure you put your bid number in the subject line, and your questions will be addressed in a timely manner. We will stop taking all questions for this IFB on July 2nd, 2020.

F. "Responsive" Bidder Criteria

- Capability of providing report as indicated
- Warranties /Guarantees
- Ability to meet specifications/bid documents as indicated.
- Service and Support Capability
- Documented licensed as required by the State of Georgia
- Applicable Bond Information as needed
- Responsible Award Amount for the Bibb County School District

G. Cancellation/Default of Contract

In the event the successful bidder, through any cause, should fail to fulfill the agreed upon obligations in an effective and timely manner, the Board shall have the right to terminate its contract by specifying the date of termination in a written notice to the selected vendor at least thirty (30) days before that termination date. The Board also reserves the right to procure the articles or services from other sources and hold the defaulting vendor responsible for any excess cost incurred.

H. Indemnity Provisions

Where bidder is required to enter or go onto property to provide services or gather information, the bidder shall be liable for any injury (including death), damage or loss occasioned by negligence of the bidder, his agent, or any person the bidder has designated to visit Board property and shall indemnify and hold harmless the Board, its officers, employees, agents and volunteers from any liability arising offerors should not include an indemnity or hold harmless agreement from the Board in any proposal. The Board will not be bound by any such agreement. Board Policy provides in part: No contract, provision, agreement or term of any procurement, contract or agreement with the Board shall obligate the Board or System to indemnify, save or hold harmless any vendor for any future claim, loss, expense or liability.

I. Errors in Bids

Bidders or their authorized representatives are expected to fully inform themselves as to conditions, requirements, and specifications before submitting bid proposals. Failure to do so will be at the

bidder's own risk. The bidder may withdraw a bid prior to the bid opening date and time by requesting to do so in writing.

J. Standards of Acceptance of Bid Proposal for Contract Award

The Board reserve the right to reject any and all bids and to waive any irregularities or technicalities in proposals received whenever such rejection or waiver is in the best interest of the Board. The Board has the right to disqualify a bid of any bidder as being unresponsive when such bidder cannot document its ability to deliver requested services or when investigation shows it is not in a position to perform the contract.

K. Compliance with Laws

The bidder shall obtain and maintain all licenses, permits, liability insurance, worker's compensation insurance and comply with any and all other standards or regulations required by Federal, State, or County statutes, ordinances and rules during the performance of any contract between the Board and the bidder. Any such requirement specifically set forth in any contract document between the bidder and the Board shall be supplementary to this section and not in substitution thereof.

L. Company Background and Experience

- Offeror will describe their background, relevant experience and qualifications including, but not limited to the following:
- Provide adequate and product as outlined
- Provide acceptable Delivery timeframes as requested
- Provide a Sample as requested

M. PREPARATION OF PROPOSAL:

Each proposal should be prepared as best as possible, however only content related to the specifications of this project should be addressed.

N. PACKAGING OF PROPOSAL: N/A Submit ONLINE only

O. EVALUATION PROCESS

The evaluation of proposals received on or before the due date and time will be evaluated by Procurement, and the Safety Committee prior to the award.

P. MANDATORY REVIEW REQUIREMENTS

Proposals which pass the administrative review will then be reviewed by the Technical Evaluation Team to ensure all requirements are satisfied as requested.

Q. REJECTION OF PROPOSALS/CANCELLATION OF IFB

The Board reserves the right to reject any or all proposals, to waive any irregularity or informality in a proposal, and to accept or reject any item or combination of items, when to do so would be to the advantage of the Board. It is also within the right of the Board to reject proposals **that do not contain all elements and information requested**



in this document. The Board reserves the right to cancel this IFB at any time. The Board will not be liable for any cost/losses incurred by the Offerors throughout this process.

BCSD NONDISCRIMINATION

The contractor, by the submission of a proposal or the acceptance of a contract, does agree that he will not discriminate against any employee or applicant for employment because of race, color, religion, sex, or national origin. The contractor shall take appropriate action to ensure that applicants are employed, and that employees are treated during employment without regard to their race, color, religion, sex or national origin. Such action shall include, but not be limited to the following: employment, upgrading, demotion, transfer, recruitment, layoff, termination, rates of pay or other forms of compensation and training. In the event of the contractor's noncompliance with the nondiscrimination policy of the BCSD, any contract or purchase order may be canceled, terminated or suspended in whole or in part and the contractor may be declared ineligible to transact further.

UTILIZATION OF MINORITY AND SMALL BUSINESS ENTERPRISES AND LOCAL AND MINORITY LABORERS

Minority and Small Business Subcontractors. The Owner has adopted a policy indicating its desire to increase the opportunity for participation by minority business enterprises and small business concerns in all its construction projects. The Contractor acknowledges this policy and agrees that it will actively solicit and encourage bids from qualified subcontractors identified by the Minority Assistance Corporation or other agencies as minority business enterprises. The Contractor shall also actively encourage and solicit bids from subcontractors who qualify as small business concerns.

Utilization of Minority and Local Labor. It is the policy of the Owner that the contractor and all subcontractors shall, consistent with efficient contract performance, utilize to the maximum extent possible minority and local laborers and mechanics as on-site employees. The Contractor acknowledges this policy and agrees that the on-site labor force of contractors and all subcontractors shall include a meaningful representation of skilled and unskilled local and minority laborers and mechanics, consistent with the efficient performance of this contract. Meaningful representation for minorities means the employment of minority laborers and mechanics in at least the same proportion that minorities are represented in a discrete construction skill or craft in Bibb County and all adjacent counties, provided such individuals are available at the time of need. Meaningful representation of local laborers and mechanics means that at least 75% of the on-site work force of contractor and all subcontractors, taken as a whole, shall reside in the Bibb County and surrounding counties, provided such individuals are available at the time of need.

DRUG-FREE WORKPLACE

By submission of a proposal, the Offeror certifies that he/she will not engage in the unlawful manufacture, sale distribution, dispensation, possession, or use of a controlled substance or drug during the performance of the contract and that a drug-free workplace will be provided for the contractor's employees during the performance of the contract. The Offeror also certifies that he will secure from any subcontractor who works on the contract, written certification of the same drug free workplace requirements. False certification or violation by failing to carry out requirements of O.C.G.A. 50-24-3 may cause suspension, termination of contract, or debarment of such Offeror.

CERTIFICATION OF NONCOLLUSION

By submitting a proposal the Offeror certifies: "that this proposal is made without prior understanding, agreement, or connection with any corporation firm, or person submitting a proposal for the same materials, supplies, or



equipment, and is in all respects fair and without collusion or fraud. That collusive pricing is understood to be a violation of State and Federal law and can result in fines, prison sentences, and civil damage awards.”

IMMIGRATION REFORM AND CONTROL ACT

Offerors must abide by all federally mandated laws enforced by United States Department of Homeland Security which are established to verify information of newly hired employees, pursuant to the Immigration Reform and Control Act of 1986 (IRCA) P.L. 99-603), in accordance with the applicability provisions and deadlines established in O.C.G.A. 13-10-91.

AUTHORIZED OFFICIAL

It is agreed that all conditions of the proposal shall be abided and that the person signing this proposal is authorized to sign the proposal for the Offeror.

SOLICITATION TERMINATION

In any event in which this solicitation is terminated or cancelled, in whole or in part, or all proposals are rejected, there shall be no liability on the part of BCSD for any costs incurred by Offerors or potential Offerors in relation to the solicitation.

RIGHTS AND REMEDIES

The rights and remedies of BCSD provided above shall not be exclusive and are in addition to any other rights and remedies provided by law or under the contract.

INSURANCE

When the selected contractor has been identified, he will be notified of the necessity to provide required insurance. Proof of insurance shall be provided within 15 days of the date of written notification to the contractor.

Worker’s Compensation and Employer’s Liability Insurance

The contractor shall procure and maintain Worker’s Compensation and Employer’s Liability Insurance in the following limits. Such insurance is to cover each and every employee who is or may be engaged in work under the contract.

Worker’s Compensation Limits: Statutory

Employer’s Liability Limits:

Bodily Injury by Accident	\$ 100,000 each accident
Bodily Injury by Disease	\$ 100,000 each employee
Bodily Injury by Disease	\$ 100,000 policy limit

Contractor waives all rights against Owner and its agents, officers, directors and employees for recovery of damages to the extent these damages are covered by the workers compensation and employer’s liability or commercial umbrella liability insurance obtained by Contractor pursuant to this agreement. The Waiver of Our Right to Recover from Others Endorsement, ISO Form SC 00 03 13 shall be attached to the policy showing the Owner listed in the Schedule.

Commercial General and Umbrella Liability Insurance

The Contractor shall procure and shall maintain commercial general liability (CGL) and if necessary, commercial umbrella insurance with a limit of not less than \$250,000 each occurrence, as shall protect him and any Subcontractor performing Work covered by this Contract from claims for damages for bodily injury, including



accidental death, as well as from claims for property damages, which may arise from operations under the Contract Agreement, whether such operations are by himself or by any Subcontractor or by anyone directly or indirectly employed by either of them.

- (1) Comprehensive Form
- (2) Contractual Insurance
- (3) Personal Injury
- (4) Broad Form Property Damage
- (5) Premises - Operations
- (6) Completed Operations

This coverage shall cover the use of all equipment, hoists, and vehicles on the site(s) not covered by Automobile Liability under the contract. Policy coverage must be on an occurrence basis.

*****Bidders shall provide two (2) copies of submitted bid proposals containing all pertinent documentation. The Board assumes no responsibility or obligation to respondents and will make no payment for any costs associated with the preparation or submission of the bid proposal. Bidders are encouraged to review carefully all provisions and attachments of this document prior to submission. Each bid proposal constitutes an offer and may not be withdrawn except as provided herein. *****