



St. Johns River Water Management District

Ann B. Shortelle, Ph.D., Executive Director

4049 Reid Street • P.O. Box 1429 • Palatka, FL 32178-1429 • (386) 329-4500
On the Internet at www.sjrwmd.com.

January 18, 2018

To: Interested Firms

From: Carol Taylor Miller, CPPO, CPPB
Telephone #: 386-329-4170
E-mail: cmiller@sjrwmd.com

Re: Quotation Request 32677 for Indian River Lagoon Continuous Monitoring Platform Installations

The St. Johns River Water Management District is requesting quotations for the above-referenced service. The firm must be licensed to do business in the state of Florida.

A Statement of Work entitled "Indian River Lagoon (IRL) Continuous Monitoring (CM) Platform Installations" is provided as Attachment 2, which includes photos and diagrams. Please read the Statement of Work; the sample agreement, Attachment 3; and the Insurance requirements, Attachment 4. The District anticipates issuing a Contract for the requested service, with a completion date of April 15, 2018.

If you have an interest in performing this work, Attachment 1 – Cost Schedule which includes a statement regarding your firm's availability of resources and ability to complete the work within the given time frame, along with a written confirmation that you understand all the terms and conditions set forth in the quote, must be signed and received in my office no later than **5:00 p.m. on Thursday, February 1, 2018**. Please reference Quotation Request #32677. Please submit the completed Attachment 1 to me as a PDF file at the email address above.

If you need assistance or have any questions about submitting your quote, please email or call me at cmiller@sjrwmd.com or 386-329-4170, respectively. Between the release of this quote request and the posting of the notice of intended decision, Respondents to this quote request or persons acting on their behalf may not contact any employee or officer of the District concerning any aspect of this solicitation, except the procurement employee listed above. Violation of this provision is grounds for rejecting a response.

A copy of the package is also available in Microsoft Word® form to assist you with your submittal.

Your quote must include the following information, which is in Attachment 1 – Cost Schedule:

1. Provide the lump sum amount for the two platforms.
2. Provide a brief statement describing your qualifications to perform the work; and your availability of resources and ability to complete the work by April 15, 2018. Also acknowledgement of your understanding of the District's requirements as outlined in the Statement of Work, sample contract, and the insurance requirements.

This letter is forwarded to you as an offer to provide a quotation based on the information and requirements provided herein, including the technical requirements stated in the attached SOW (Attachment 2). Insurance requirements are provided in Attachment 4.

The quotation shall include all costs associated with the services to be provided for the fabrication, building, and installation of the two identical, stable, free-standing platforms within the IRL. The lump sum amount submitted shall include all labor, materials, and travel associated with this work.

Once the quotes have been received, District staff will review and contact firms for further clarification if needed.

The District is a political subdivision of the state of Florida, whose boundaries cover all or portions of 18 counties, and is tax exempt (Tax ID No. 85-8012643710C-3; expires March 31, 2018).

1. Opening of Quotes

- A. The Florida Public Records Act, §119.071(1)(b), Fla. Stat., exempts sealed quotes from inspection and copying until such time as the District provides notice of an intended decision pursuant to §120.57(3)(a), Fla. Stat., or until 30 days after opening of quotes, whichever is earlier. This exemption is not waived by the public opening of quotes.
- B. Unless otherwise exempt, Respondent's quote is a public record that is subject to disclosure upon expiration of the above exemption. If any information submitted with the Quote is a trade secret as defined in §812.081, Fla. Stat., and exempt from disclosure pursuant to §815.04, Fla. Stat., Respondent must clearly identify any such material as "CONFIDENTIAL TRADE SECRET" in its submittal and explain the basis for such exemption. The District reserves the right, in its sole judgment and discretion, to reject a submittal for excessive or unwarranted assertion of trade secret confidentiality and return the submittal to Respondent.
- C. Respondents shall bear all costs associated with preparing and submitting responses to this Quote Request. The District will, in no way, be responsible for these costs, regardless of the conduct or outcome.

2. Inquiries and Addenda

- A. District staff are not authorized to orally interpret the meaning of the Quote Request package, or correct any apparent ambiguity, inconsistency, or error therein. In order to be binding upon the District, the interpretation or correction must be given by the Procurement Specialist and must be in writing. The Procurement Specialist may orally explain the District's procedures and assist Respondents in referring to any applicable provision in the Quote Request documents, but the Respondent is ultimately responsible for submitting the quote in the appropriate form and in accordance with written procedures.
- B. Every request for a written interpretation or correction must be received at least nine days prior to opening of quotes in order to be considered. Requests must be submitted by email to cmiller@sjrwmd.com. Interpretations, corrections, and supplemental instructions will be communicated by written addenda to this solicitation posted by Onvia DemandStar to all prospective Respondents (at the respective addresses furnished for such purposes) not later than five days prior to the date fixed for the Quote Request opening.
- C. Submission of a quote constitutes acknowledgment of receipt of all addenda. Quotes will be construed as though all addenda had been received. Failure of the Respondent to receive any addenda does not relieve Respondent from any and all obligations under the quote, as submitted. All addenda become part of the Agreement.

3. Award Procedures

- A. Section 286.0113, Fla. Stat., exempts from being open to the public, any portion of a meeting at which: (1) a negotiation with a Respondent is conducted pursuant to a competitive solicitation; (2) a Respondent makes an oral presentation as part of a competitive solicitation; (3) a Respondent answers questions as part of a competitive solicitation; or (4) negotiation

strategies are discussed. Also, recordings of, and any records presented at, the exempt meeting are exempt from §119.07(1) and §24(a), Art. I of the State Constitution (Public Records) until such time as the District provides notice of an intended decision or until 30 days after opening the Quotes or final replies, whichever occurs earlier. A complete recording shall be made of any portion of an exempt meeting. No portion of the exempt meeting may be held off the record.

- B. Pursuant to §286.0113 Fla. Stat., if the District rejects all quotes and concurrently provides notice of its intent to reissue the competitive solicitation, the recording and any records presented at any exempt meeting shall remain exempt from §119.07(1) and §24(a), Art. I of the State Constitution (Public Records) until such time as the District provides notice of an intended decision concerning the reissued competitive solicitation or until the District withdraws the reissued competitive solicitation. A recording and any records presented at an exempt meeting are not exempt for longer than 12 months after the initial District notice rejecting all quotes.
- C. The District will examine the quotes to determine completeness. Obvious mismatches with regard to technical or commercial requirements will be rejected at this time.
- D. If two or more quotes are equal in all respects, the Agreement will be awarded as follows: (1) to the Respondent that certifies compliance with §287.087, Fla. Stat., via the Drug-Free Workplace Form; or (2) by lot.
- E. In the event the Successful Respondent(s) fail to enter into the Agreement or the Agreement with said Respondent is terminated within 90 days of the effective date, the District reserves the right to negotiate with the other respondents in ranked order, if available, and award an Agreement.
- F. All Respondents will be notified of the District's intent to award or decision to award the Agreement. For the purpose of filing a protest under §120.57(3), Fla. Stat., the time period will commence as provided in "Notices and Services Thereof."

4. Disqualification of Respondents

Any of the following causes will be considered as sufficient grounds for disqualification of a Respondent and rejection of the Quote:

- A. Contacting a District employee or officer other than Carol Miller, the procurement specialist assigned to this solicitation action, about any aspect of this Quote Request before the notice of intended decision is posted.
- B. Submission of more than one quote response for the same subject matter by an individual, firm, partnership, or corporation under the same or different names;
- C. Evidence of collusion among Respondents;
- D. Submission of materially false information with the Quote;
- E. Information gained through checking of references or other sources which indicates that Respondent may not successfully perform the Work;
- F. Respondent is failing to adequately perform on any existing contract with the District;
- G. Respondent has defaulted on a previous contract with the District;
- H. The evidence submitted by Respondent, or the District's investigation of Respondent, fails to satisfy the District that Respondent is properly qualified to carry out the obligations of the Agreement in a manner acceptable to the District and within the time period specified;
- I. Any other cause that is sufficient to raise doubt regarding the ability of a Respondent to perform the Work in a manner that meets the District's objectives for the Work.

5. Rejection of Quote

- A. Quotes must be emailed to the specified location and received during the time specified on page 1 in order to be considered timely. Untimely quotes will not be considered. Quotes will be considered irregular and may be rejected if they show material omissions, alterations of

form, additions not called for, conditions, limitations, unauthorized alternate quotes, or other material irregularities. The District may consider incomplete any quote not prepared and submitted in accordance with the provisions specified herein, and reserves the right to waive any minor deviations or irregularities in an otherwise valid Quote.

- B. The District also reserves the right to reject any and all quotes when it determines, in its sole judgment and discretion that, it is not in its best interest to award the agreement.

6. Diversity

The District is committed to the opportunity for diversity in the award and performance of all procurement activities. The District encourages its primary respondents to make a good faith effort to ensure that women and minority-owned business enterprises (W/MBE) are given the opportunity for maximum participation as second and lower tier participants. The District will assist Respondents by sharing information on W/MBEs to encourage their participation.

7. Public Entity Crimes/Discriminatory Vendors

In accordance with §287.133 and §287.134, Fla. Stat., a person or affiliate who has been placed on the convicted or discriminatory vendor lists following a conviction for a public entity crime or placement on the discriminatory vendor list may not submit a bid, proposal, or reply on a contract to provide any goods or services to a public entity; may not submit a bid, proposal, or reply on a contract with a public entity for the construction or repair of a public building or public work; may not submit bids, proposals, or replies on leases of real property to a public entity; may not be awarded or perform work as a contractor, supplier, subcontractor, or Contractor under a contract with any public entity; and may not transact business with any public entity in excess of the threshold amount provided in §287.017 for CATEGORY TWO (\$35,000) for a period of 36 months following the date of being placed on the convicted or discriminatory vendor lists.

8. Notices and Services Thereof

- A. The District will publish notice of specifications and criteria, including addenda, intended agency decisions, or other matters pertinent to this solicitation on Onvia DemandStar at DemandStar.com. Onvia DemandStar may also be accessed through the District's website at sjrwmd.com. In addition, the District will post notices of intended agency decisions at the District's headquarters, 4049 Reid Street, Palatka, Florida, Administration Building, Procurement Bulletin Board, on the date the publication is posted on Onvia DemandStar.
- B. Notices that are posted on Onvia DemandStar are deemed received at 8:00 a.m. on the next business day following the date posted. Notices that are posted at the District's Procurement Bulletin Board are deemed received at 8:00 a.m. on the next business day following the date of posting. Notices will be posted for a minimum of 72 hours following the time at which they are deemed received. The time period for filing a Notice of Protest pursuant to §120.57(3), Fla. Stat., and Rule 28-110.003, Fla. Admin. Code, commences at the time notices are deemed received.
- C. As a courtesy to Respondents, the District may send copies of the notices of intended agency decisions via email or facsimile to the address or phone number provided by Respondent. These courtesy communications neither constitute official notice nor vary the times of receipt set forth above.

9. Protest Procedures

- A. Pursuant to §120.57(3), Fla. Stat., and Rule 28-110.003, Fla. Admin. Code, any person adversely affected by the procurement methodology described herein, or the specifications or criteria, including addenda, must file a Notice of Protest within 72 hours after receipt of the solicitation documents or addenda.
- B. Pursuant to §120.57(3), Fla. Stat., and Rule 28-110.003, Fla. Admin. Code, any person adversely affected by a District decision or intended decision to award a contract, or to reject all responses must file a Notice of Protest within 72 hours after receipt of the decision or

intended decision. Pursuant to §287.042(2)(c), Fla. Stat., any person who files an action protesting the decision or intended decision must post with the District Clerk at the time of filing the formal written protest a bond, cashier's check, or money order made payable to the St. Johns River Water Management District in an amount equal to one percent of the District's estimated contract amount.

- C. Pursuant to §120.57(3), Fla. Stat., and Rule 28-110.004, Fla. Admin. Code, the protester must also file with the District Clerk a Formal Written Protest within ten days after the date the Notice of Protest is filed with the District. The Formal Written Protest must state with particularity the facts and law upon which the protest is based.
- D. No additional time will be added for mailing. All filings must comply with Rule 28-106.104, Fla. Admin. Code, and must be addressed to and received by the District Clerk at the District Headquarters in Palatka, Florida within the prescribed time periods. The District will not accept as filed any electronically transmitted facsimile pleadings, petitions, Notice of Protest or other documents. Failure to file a protest within the time prescribed in §120.57(3), Fla. Stat., or failure to post the bond or other security required by law within the time allowed for filing a bond will constitute a waiver of proceedings under chapter 120, Fla. Stat. Mediation under §120.573, Fla. Stat., is not available.

**ATTACHMENT 1 - QUOTATION
INDIAN RIVER LAGOON (IRL)
CONTINUOUS MONITORING (CM) PLATFORM INSTALLATIONS**

The purpose of this work is to construct two (2) permitted, identical, stable, free-standing platforms within the IRL by April 15, 2018. See the Items included in the Scope of Work for construction specifications and platform locations.

Please indicate the lump sum amount that would be charged for the 2 platforms, considering all information provided in the Statement of Work, Attachment 2. The award will be based on the lowest lump sum amount provided for the 2 sites, from the qualified firm who can meet the time frame and provide required insurance. The lump sum will include all labor and materials necessary to fabricate, field construct and secure platform decking. The lump sum must also include all travel, safety equipment, hand tools, and any other expenses associated with completing this project.

This lump sum amount is being used for quotation purposes. In the event of a delay in permitting or other issues, the 2 sites may not be completed. The District will pay for each successfully completed site; each site will be valued at one-half of the lump sum amount.

Please put the Lump Sum Amount for construction of the 2 platforms as described in Attachment 2 – Statement of Work on the line below.

\$ _____

Please state your firm’s qualifications to perform this work, availability of resources and ability to complete the work within the given time frame: (you may add additional pages)

ATTACHMENT 1 – QUOTATION (Page 2)
(This page must be submitted with Quote)

I hereby acknowledge, as Respondent's authorized representative, that I have fully read and understand all terms and conditions as set forth in this Quote and upon award of such Quote, shall fully comply with such terms and conditions.

Date

Respondent (firm name)

Address

E-mail address

Telephone Number

Signature

Typed name and title

**ATTACHMENT 2 – STATEMENT OF WORK
INDIAN RIVER LAGOON (IRL) CONTINUOUS MONITORING (CM) PLATFORMS**

I. INTRODUCTION/BACKGROUND

The St. Johns River Water Management District (District) mission statement, “To protect our natural resources and support Florida’s growth by ensuring the sustainable use of Florida’s water for the benefit of the people of the District and the state” challenges the District to address critical issues affecting jurisdictional water bodies. Recent ecological changes such as algal blooms, continued seagrass decline and major fish kills in the IRL have prompted the District, in partnership with the Florida Department of Environmental Protection (FDEP) and several local governmental agencies, to step up efforts to monitor water quality on a much finer temporal scale than previously attempted. Recent technological advancements for the in situ, real-time monitoring of various water quality parameters within the IRL have the potential to quickly define and capture chemical and ecological process that before may have gone undetected. This early, real-time detection could be instrumental in supporting the management decisions needed to manage the resource.

The initial deployment methodology for the continuous monitoring (CM) instruments, located on bridge fenders under major causeways over the IRL, proved to be very problematic from a safety standpoint due to boat wakes and lack of suitable mooring. This Statement of Work is intended to alleviate the unnecessary safety risks by fabricating and installing free-standing, secure platforms on which to install the instruments. These platforms will be safer to access during equipment service and will foster greater public awareness from a standpoint of visibility. In addition, this relocation of the instruments will align and compliment data collected by other stakeholders and facilitate the uninterrupted, publicly available data feed. Platforms will be built and installed under permit guidelines as established by the United States Coast Guard and the United States Army Corps of Engineers.

II. OBJECTIVES

The purpose of this work is to construct two (2) permitted, identical, stable, free-standing platforms within the IRL by April 15, 2018. See the Items included in this Statement of Work for construction specifications and platform locations.

III. SCOPE OF WORK

The contractor shall fabricate, build and install two (2) identical platforms in the IRL as described herein and indicated in Items 1.1 through 1.5.

The contractor shall provide or perform:

- All labor and materials necessary to fabricate, field construct and secure platform decking (Items 1.1 through 1.5) to the supporting structure included in this Statement of Work.
- Ability to drive the supporting superstructure (stainless steel pipe and braces) to refusal. The term refusal as it relates to installation is defined as the driven pipe stops movement for 5 seconds while the hydraulic pounder is exerting a driving force. The supporting superstructure shall be hydraulically hammered, not jetted.
- Transportation for contractor, labor, materials and tools to and from boat ramps.
- Labor necessary to load all construction materials onto the work vessel.
- Safety equipment necessary for contractor and their staff, e.g. life jackets, gloves, cell phone, drinking water, etc.
- All hand tools and power tools necessary to complete the installation, which includes, but is not limited to; wrenches, portable band saw, drills and drill bits suitable for drilling Schedule 40 stainless steel pipe, appropriate power generator, straps, ladders and hydraulic pounder or hammer sufficient to drive the legs and braces to refusal.

- All additional material and hardware to construct the completed structure, which includes, but is not limited to; stainless steel pipe, bolts, nuts, washers, couplings, speedrail couplings, unistrut brackets, unistrut clamps, PVC stilling well pipes, well caps and PVC caps for ends of pipe.

The District shall provide:

- A stable vessel or barge suitable to perform the installation.
- Transport of the vessel to the work site.
- A Captain to pilot the vessel.
- All applicable permits necessary for placement of the platform.
- A biologist to monitor installation activities if required by permit (seagrass, sea turtle, smalltooth sawfish, manatee).

Common issues:

- All metal material shall be 316 stainless steel except as noted in the following bullet.
- Deck material shall be aluminum as noted below and on Items 1.1 through 1.5:

KEY NOTES: NO SHARP EDGES OR BURRS ON ANY METAL.			
NO.	QUANTITY	DESCRIPTION	MODEL/NAME
①	2	PLATFORM DECK	PCS ALUM/6063-T6 GAL150 SERR 1½" X ⅜" BEARING BARS ON 1⅜" CENTERS (36" W X 71¼" LG)
②	4	FRAME MOUNTING PLATE	STRUCTURAL ANGLE, 3" X 3" X 1/4" (71 1/2" LG)
③	2	FRAME MOUNTING PLATE	STRUCTURAL ANGLE, 3" X 3" X 1/4" (71 1/2" LG)
④	4	FRAME MOUNTING PLATE	PCS 5052-H32 ALUM, 1/4" X 11" X 12"
⑤	4	FRAME MOUNTING PLATE	PCS 5052-H32 ALUM, 1/4" X 12" X 8"

- The water depth at all sites is approximately 6 to 7 feet.
- See Item 2 for a map of platform locations.
- No welding will be required during field construction.
- This contract does not include installation of telemetry equipment as shown in Items 4.0 and 4.1.
- Full size documents of all Items available upon request.

IV. TASK IDENTIFICATION

The contractor shall provide all material, labor and tools necessary to fabricate/build and install two platforms. During installation, each corner support leg shall be driven to refusal. The angled bracing supports are driven to refusal, or to a point where at least 6 inches of pipe remains to drill and attach the brace at the juncture of the leg above water. See Items 3, 3.1, 3.2, 4.0, 4.1 and 4.2 for additional views of platform.

V. TIME FRAMES AND DELIVERABLES

Actual on-site construction and installation of the platform in the IRL shall not commence until all necessary permits have been received. All referenced work and final disposition of the contract is expected to be completed by April 15, 2018.

PLATFORM MUST BE MODIFIED TO A 3' X 6' DIMENSION, BUT MUST MAINTAIN THE MULTIPLE BRACING AND CUT OUT FOR THE BENCHMARK. NO OTHER CHANGES ARE REQUIRED,

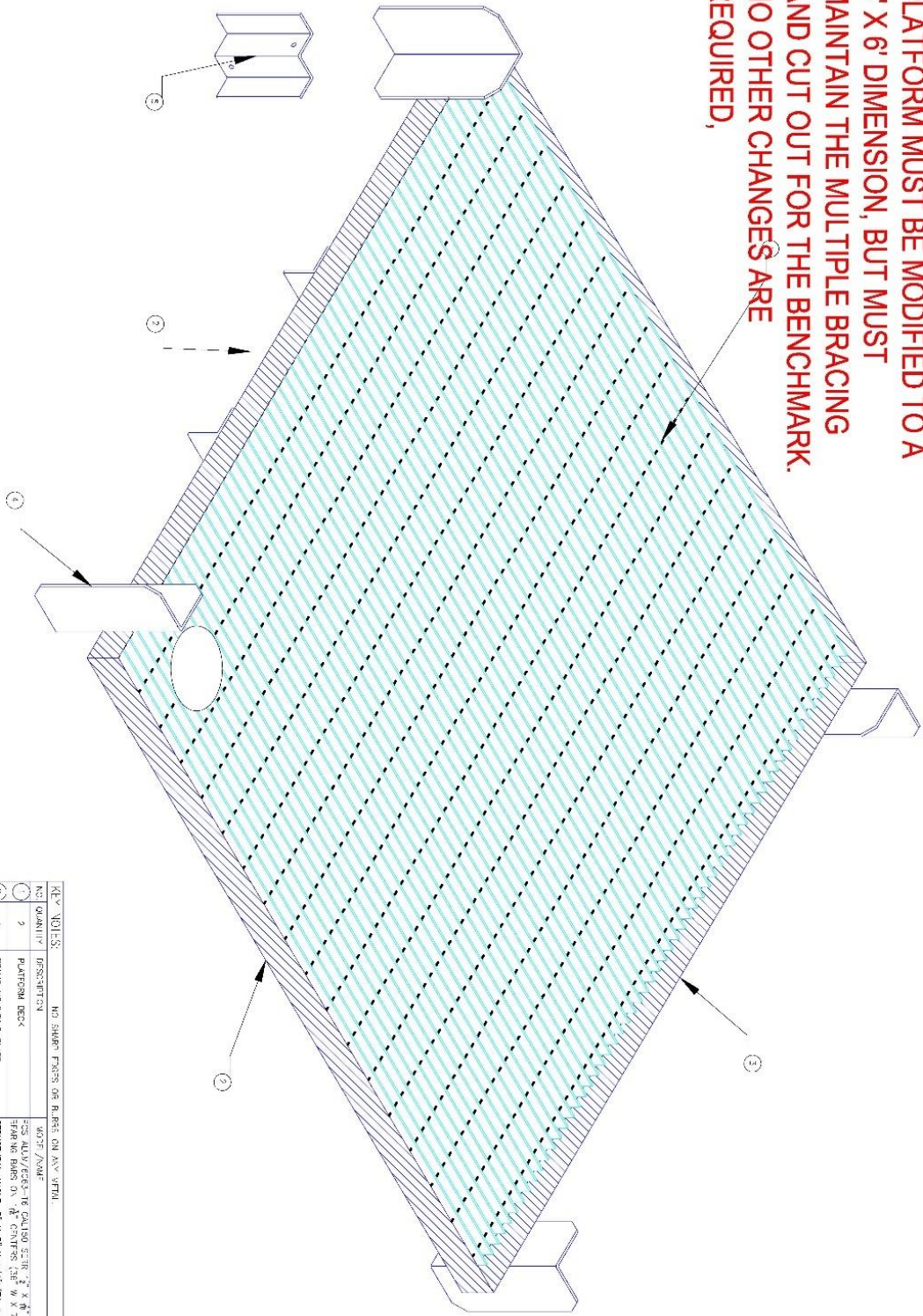

REV NOTES: NO SHARP EDGES OR RIBS ON ANY VERTICAL

REV	QUANTITY	DESCRIPTION	NOTE / DIMS
1	2	PLATFORM DECK	20S ALU/ALC. TO GALVALUM 52.36" X 72" X 8"
2	4	FRAME COATING PLATE	FRAMING BARS ON 1/4" CENTERS (36" X 72" X 1/4")
3	2	FRAME COATING PLATE	STRUCTURAL ANGLE 3" X 3" X 1/4" (71" 1/2" X 101")
4	4	FRAME COATING PLATE	20S 5052-H19 ALUM. 1/4" X 12" X 12"
5	4	FRAME COATING PLATE	20S 5052-H19 ALUM. 1/4" X 12" X 8"

3
5

**6' X 6' METAL PLATFORM
PLATFORM ISO VIEW**



**SOUTH FLORIDA
WATER MANAGEMENT DISTRICT**

PROJECT NO. 1
DATE: 04/11/2011

NOT SCALE
IT IS THE RESPONSIBILITY OF THE CONTRACTOR TO VERIFY ALL DIMENSIONS AND CONDITIONS OF THE DISTRICT AND TO BE RESPONSIBLE FOR OBTAINING ALL NECESSARY PERMITS AND APPROVALS. THE CONTRACTOR SHALL COMPLY WITH Florida Statutes 118.07 (5) AND 118.07 (6) AND 118.07 (7) AND 118.07 (8) AND 118.07 (9) AND 118.07 (10) AND 118.07 (11) AND 118.07 (12) AND 118.07 (13) AND 118.07 (14) AND 118.07 (15) AND 118.07 (16) AND 118.07 (17) AND 118.07 (18) AND 118.07 (19) AND 118.07 (20) AND 118.07 (21) AND 118.07 (22) AND 118.07 (23) AND 118.07 (24) AND 118.07 (25) AND 118.07 (26) AND 118.07 (27) AND 118.07 (28) AND 118.07 (29) AND 118.07 (30) AND 118.07 (31) AND 118.07 (32) AND 118.07 (33) AND 118.07 (34) AND 118.07 (35) AND 118.07 (36) AND 118.07 (37) AND 118.07 (38) AND 118.07 (39) AND 118.07 (40) AND 118.07 (41) AND 118.07 (42) AND 118.07 (43) AND 118.07 (44) AND 118.07 (45) AND 118.07 (46) AND 118.07 (47) AND 118.07 (48) AND 118.07 (49) AND 118.07 (50) AND 118.07 (51) AND 118.07 (52) AND 118.07 (53) AND 118.07 (54) AND 118.07 (55) AND 118.07 (56) AND 118.07 (57) AND 118.07 (58) AND 118.07 (59) AND 118.07 (60) AND 118.07 (61) AND 118.07 (62) AND 118.07 (63) AND 118.07 (64) AND 118.07 (65) AND 118.07 (66) AND 118.07 (67) AND 118.07 (68) AND 118.07 (69) AND 118.07 (70) AND 118.07 (71) AND 118.07 (72) AND 118.07 (73) AND 118.07 (74) AND 118.07 (75) AND 118.07 (76) AND 118.07 (77) AND 118.07 (78) AND 118.07 (79) AND 118.07 (80) AND 118.07 (81) AND 118.07 (82) AND 118.07 (83) AND 118.07 (84) AND 118.07 (85) AND 118.07 (86) AND 118.07 (87) AND 118.07 (88) AND 118.07 (89) AND 118.07 (90) AND 118.07 (91) AND 118.07 (92) AND 118.07 (93) AND 118.07 (94) AND 118.07 (95) AND 118.07 (96) AND 118.07 (97) AND 118.07 (98) AND 118.07 (99) AND 118.07 (100)

Item 1.1

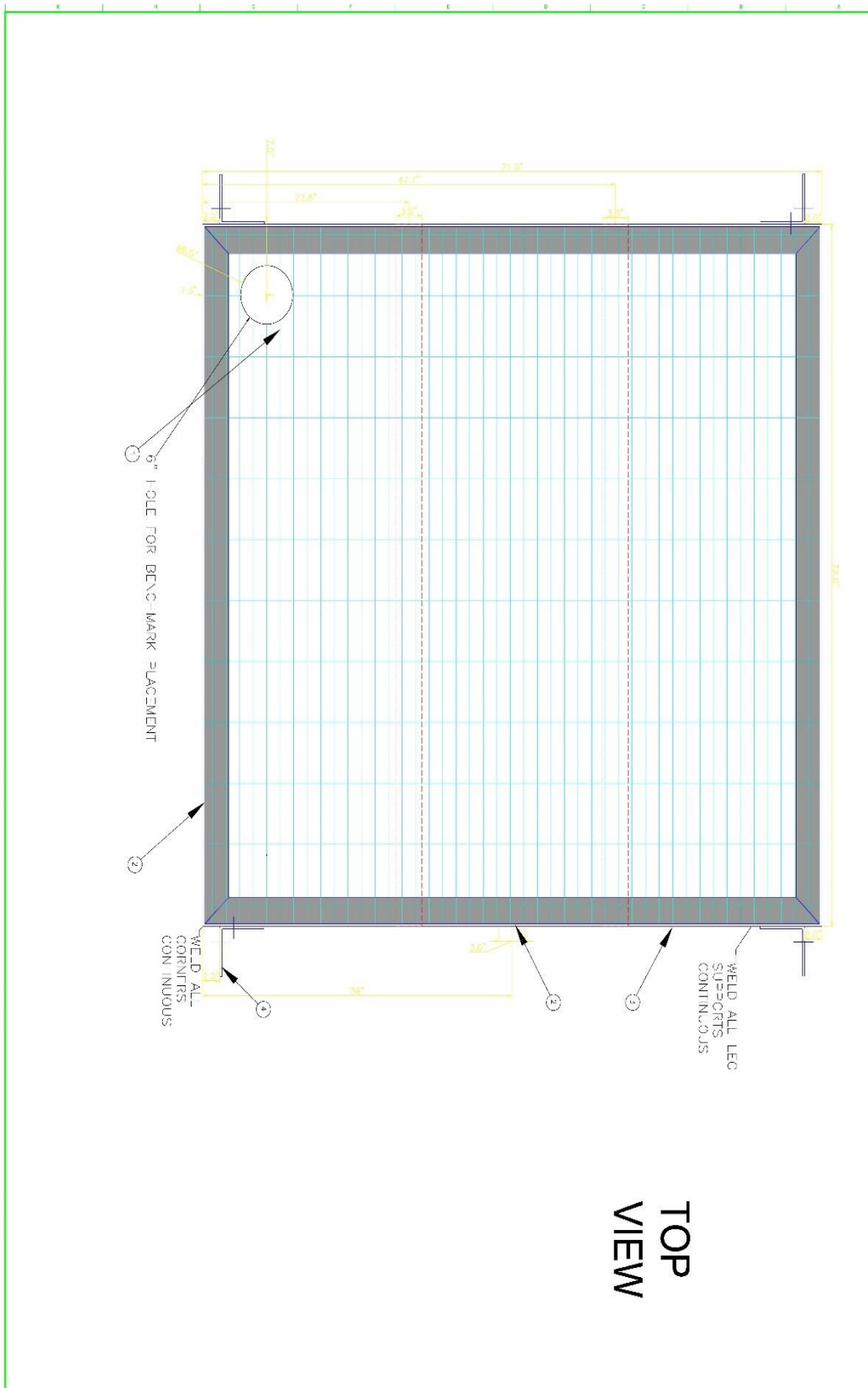

**TOP
VIEW**

<p>2 1/8" = 1'</p>	<p>1 6' X 6' METAL PLATFORM TOP VIEW</p>	 <p>SOUTH FLORIDA WATER MANAGEMENT DISTRICT</p>	<p>APPROVED: _____ PROJECT NO.: _____ DATE: _____</p>	<p>PLAT SCALE: 1" = 1'-0" DRAWN BY: M. S. SUTTON The consultant, contractor or other parties associated with District projects shall comply with Florida Statutes 19.07 (6) (c). These Statistics and Guidelines are the property of the District and must be secured and maintained in a confidential manner. Disclose to any unauthorized individual or outside party not performing work necessary to District projects is prohibited.</p>
------------------------	---	---	---	---

Item 1.2

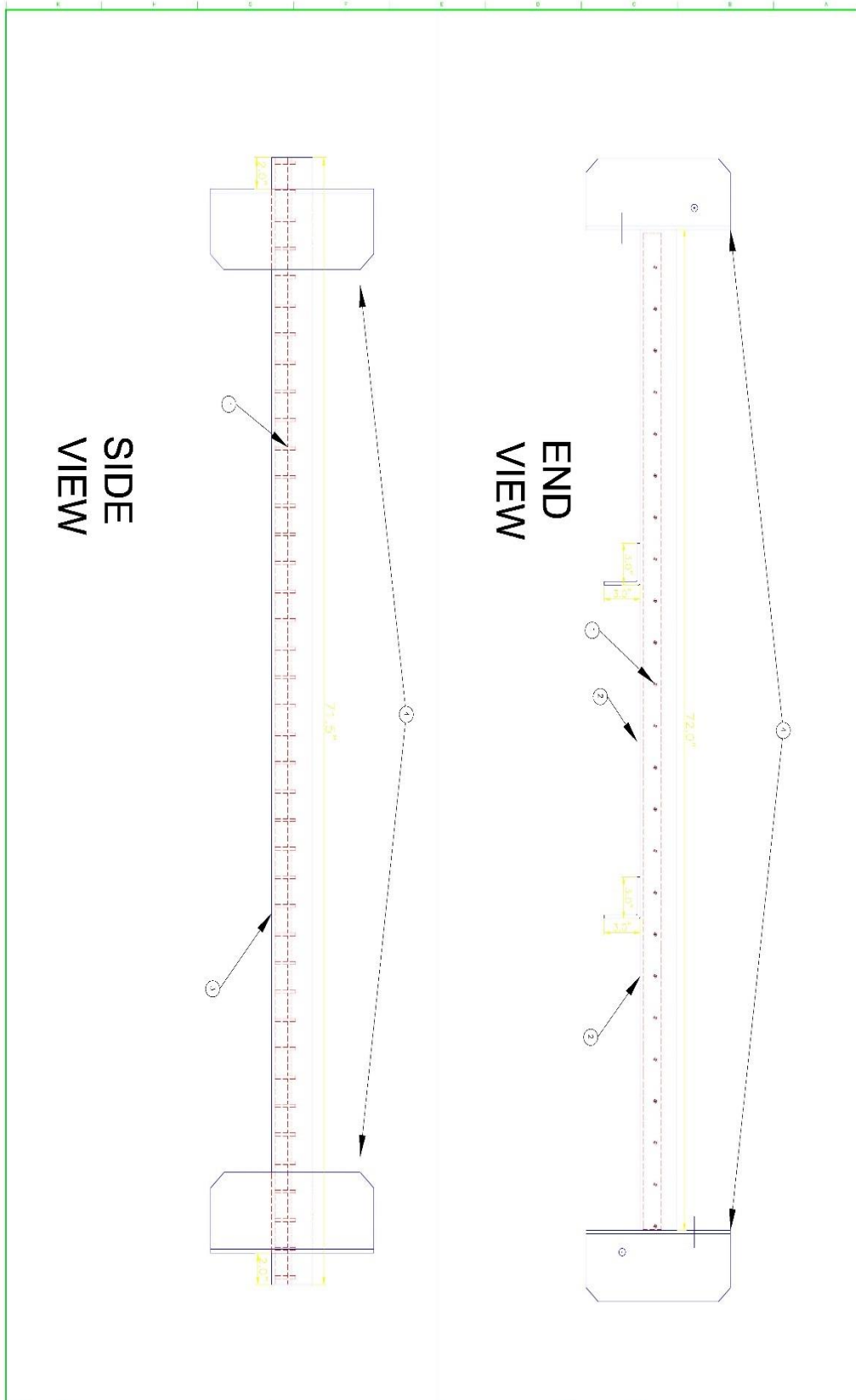

3 SHEET 5	1	6' X 6' METAL PLATFORM PLATFORM VIEWS	 SOUTH FLORIDA WATER MANAGEMENT DISTRICT	MFC# 1 DESIGN No. 1 ITEM No. 104_2012	ITEM SCALE: 1" = 10' BY: W. J. L. JAMES
				<small>The contractor, contractor or other parties associated with District projects shall comply with Florida Statute 118.07 (3) (a). These standards and guidelines are the property of the District and must be stored and maintained in a confidential manner. Review by any unauthorized individual or outside third party not performing work necessary for District projects is prohibited.</small>	

Item 1.3

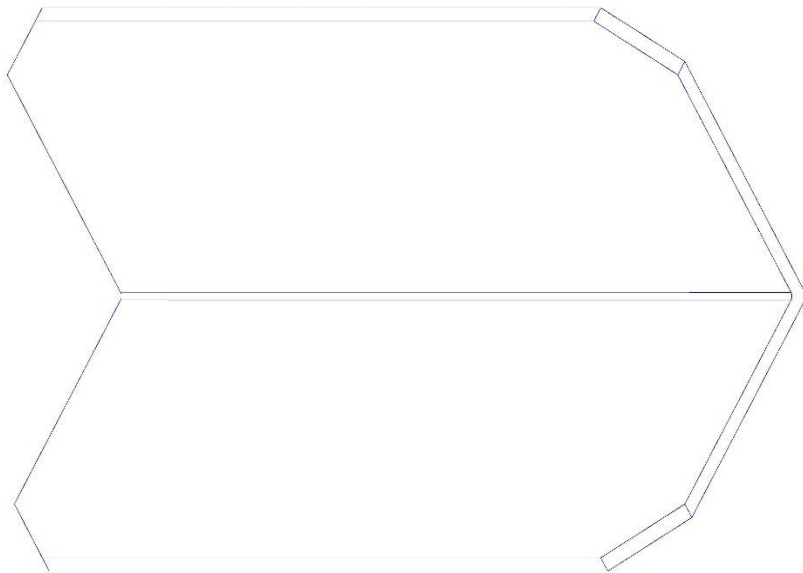
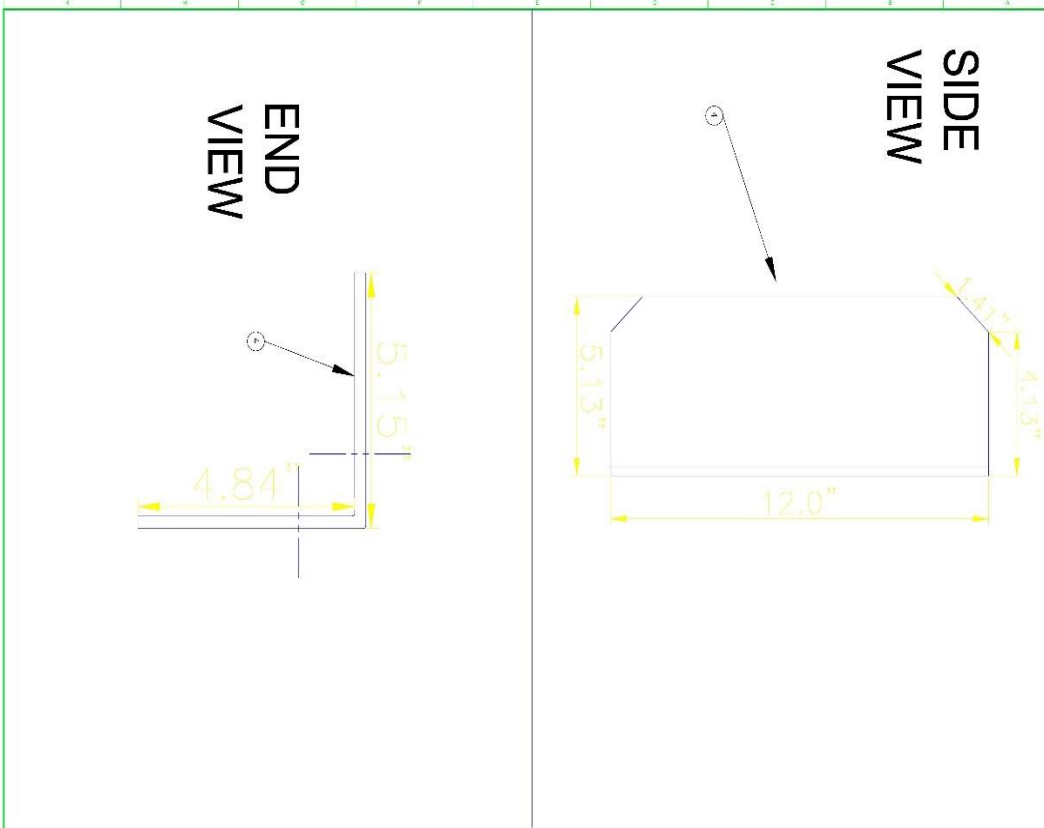

4 REV 5	4	6' X 6' METAL PLATFORM LEG BRACKET< PART A		SOUTH FLORIDA WATER MANAGEMENT DISTRICT	DWP-CALD _____ REVISION NO. 1 UTILITY NO. 24_1_06_2024	SHEET TOTAL: 11 FILE NAME: METAL_PLATFORM
					<small>The manufacturer, contractor or other parties associated with District projects shall comply with Florida Statutes 113.07 (6) (c). These Standards and Guidelines are the property of the District and must be returned and destroyed in a confidential manner. Review by any contractor, individual or entity/3rd party not performing work necessary for District projects is prohibited.</small>	

Item 1.4

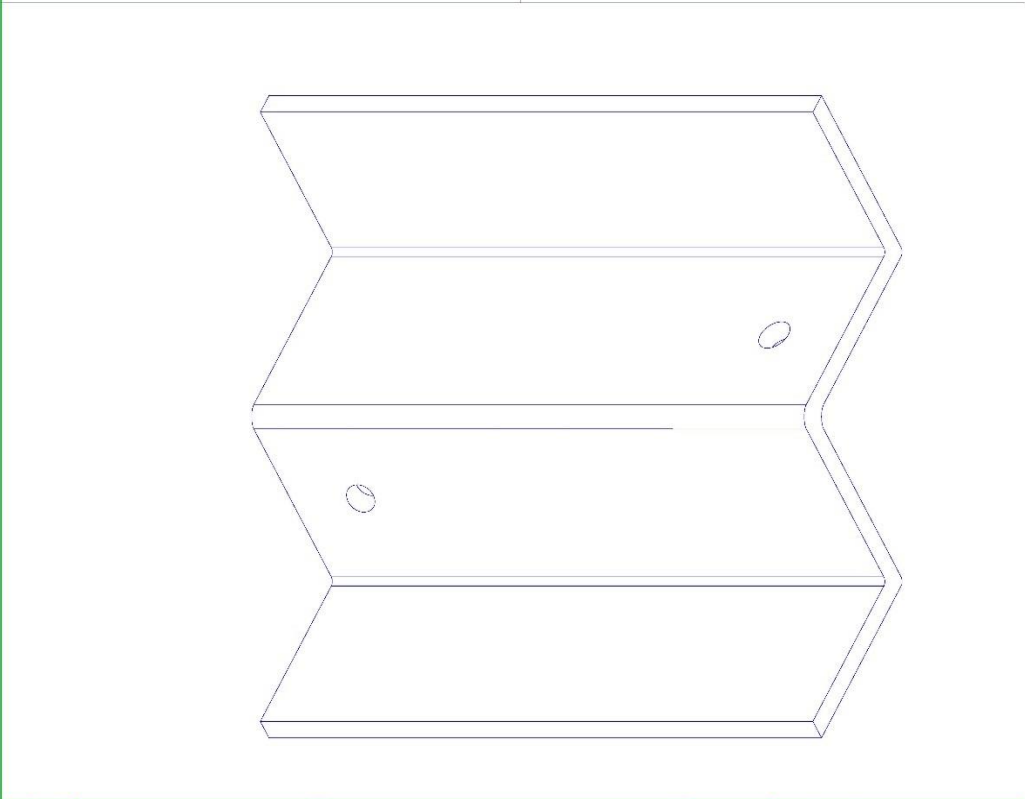
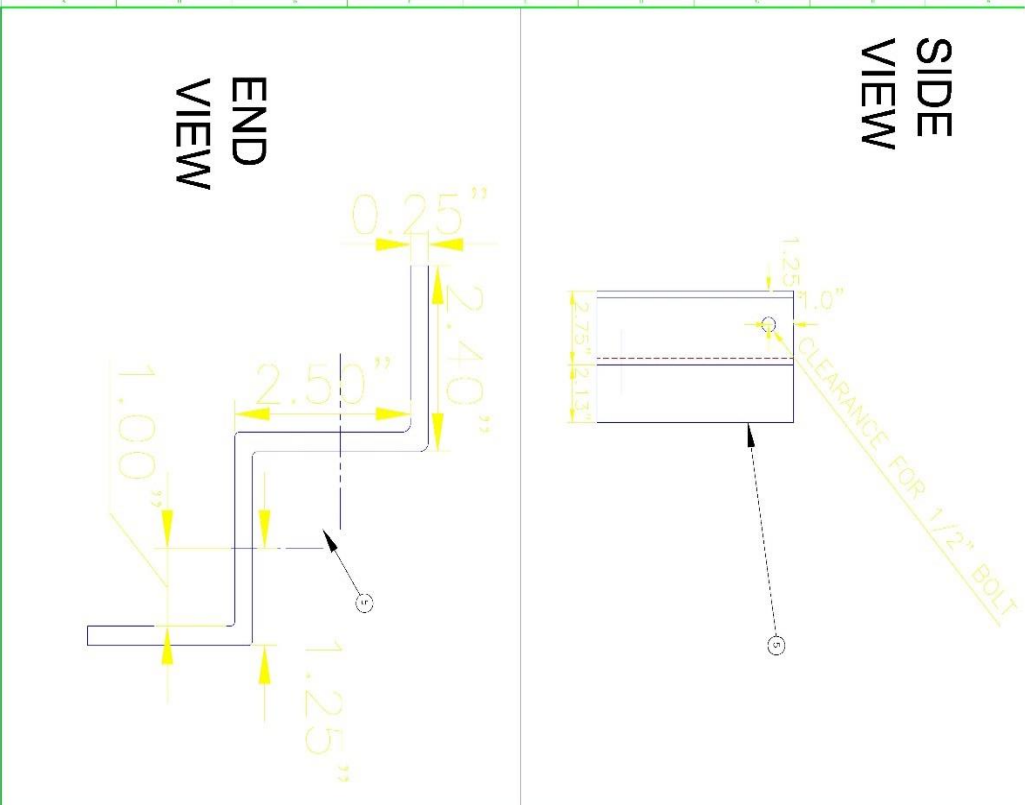

5 6 5	5	6' X 6' METAL PLATFORM LEG BRACKET, PART B	 <p>SOUTH FLORIDA WATER MANAGEMENT DISTRICT</p>	APPROVED: _____ DRAWING NO.: _____ EFFECTIVE DATE: 2nd, 2022	TITLE: SCRAP: _____ FILE NUMBER: 201101010
-------------	---	---	---	--	---

The contractor, contractor or other parties associated with this project shall comply with Florida Statutes 119.07 (1) (a), (b), (c) and (d) and all applicable rules and regulations of the District and must be licensed, bonded and insured in accordance with the requirements of the District. The contractor shall be responsible for obtaining all necessary permits and approvals for this project and shall be responsible for obtaining all necessary permits and approvals for this project and shall be responsible for obtaining all necessary permits and approvals for this project.

Item 1.5

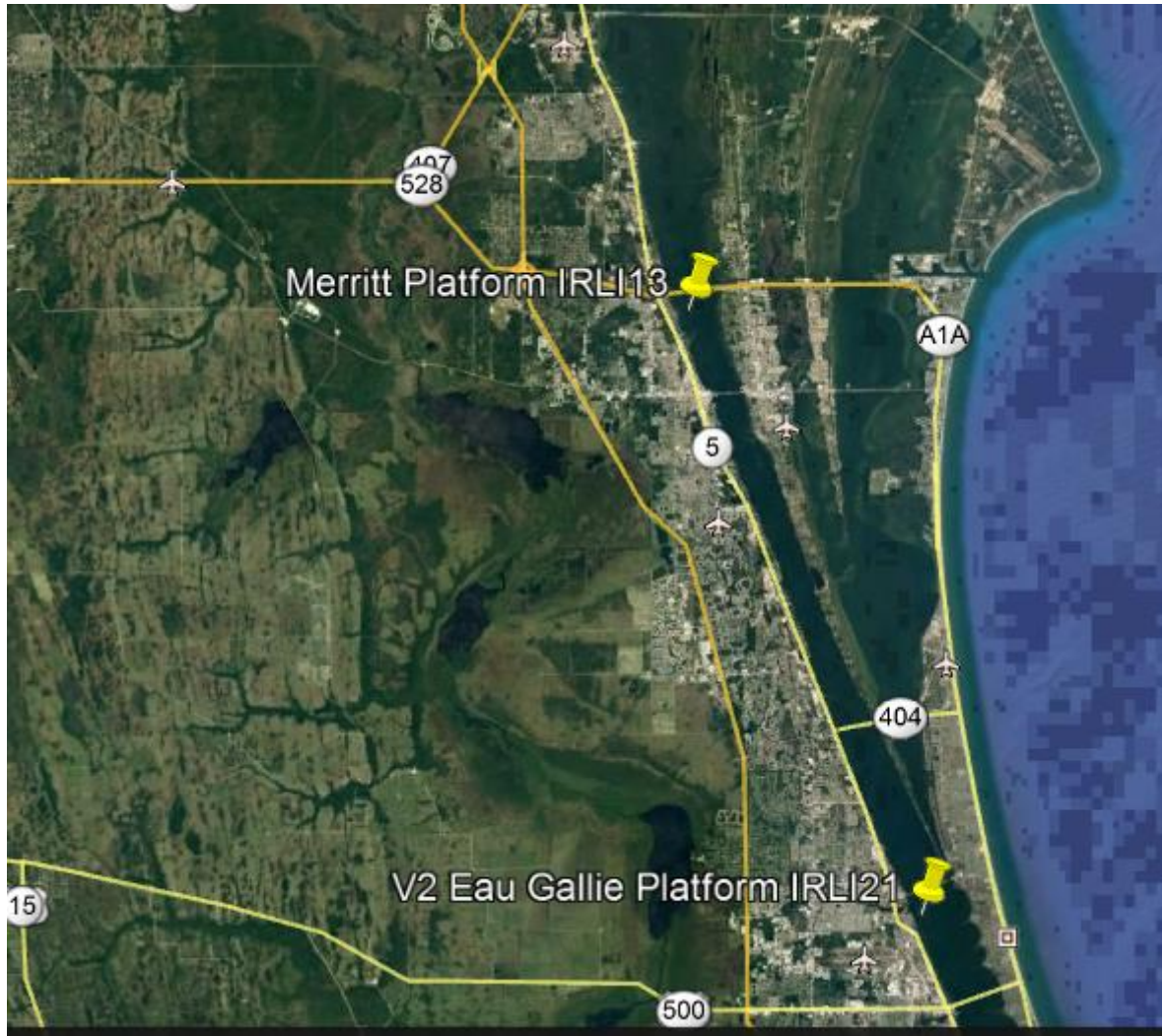

Item 2

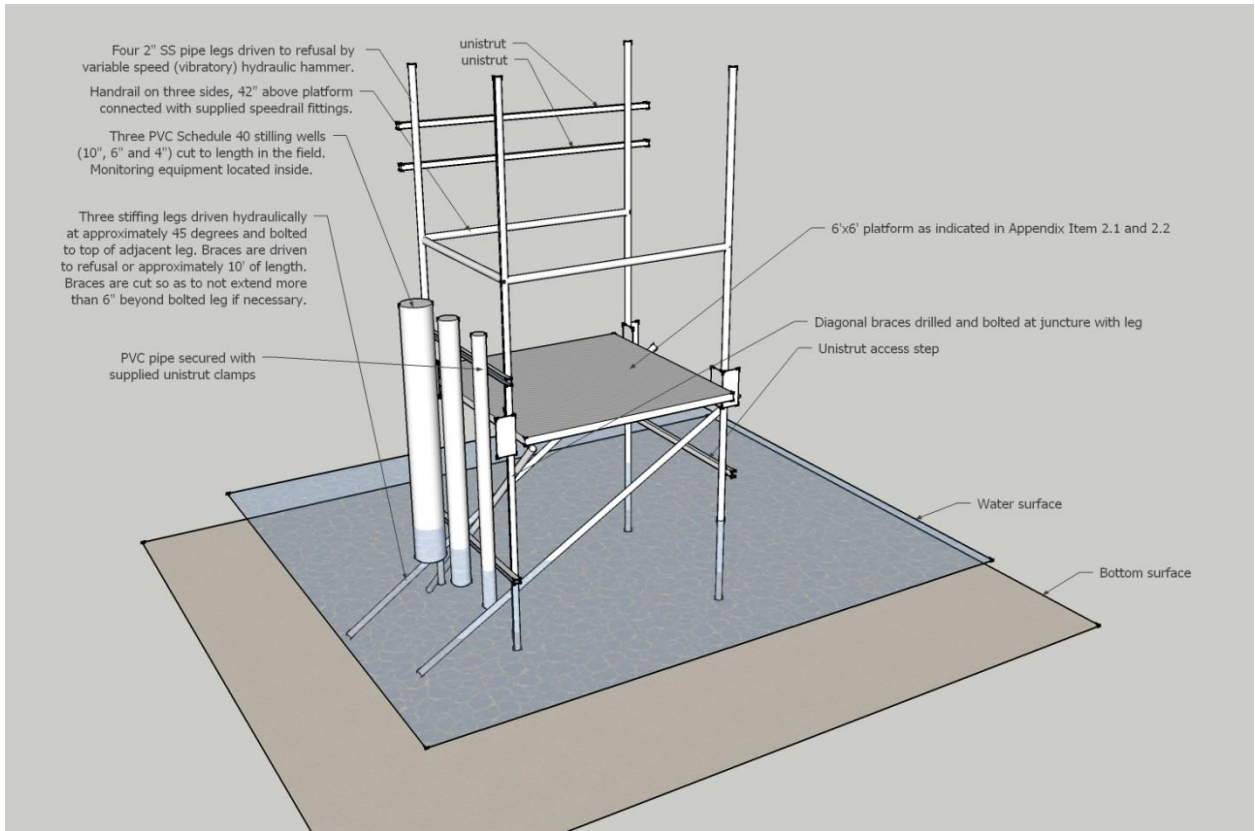

Item 3

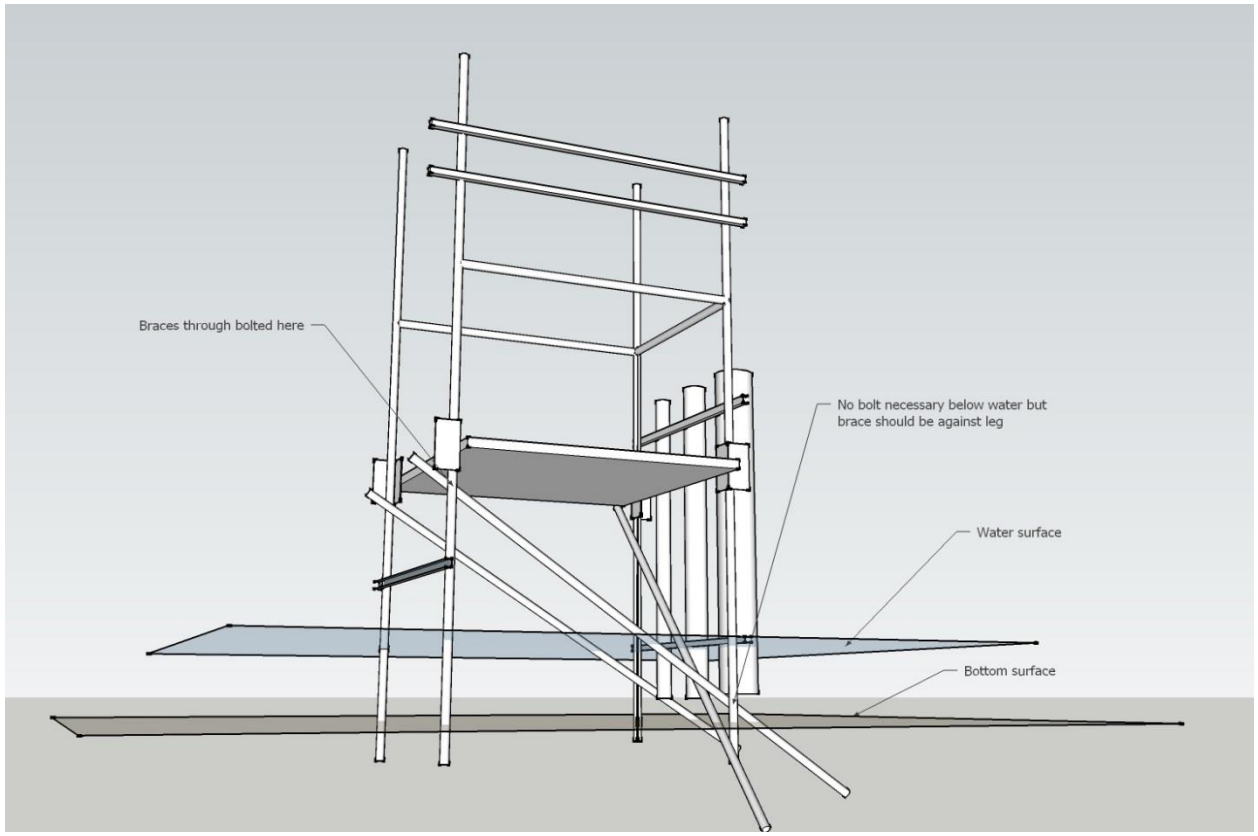

Item 3.1

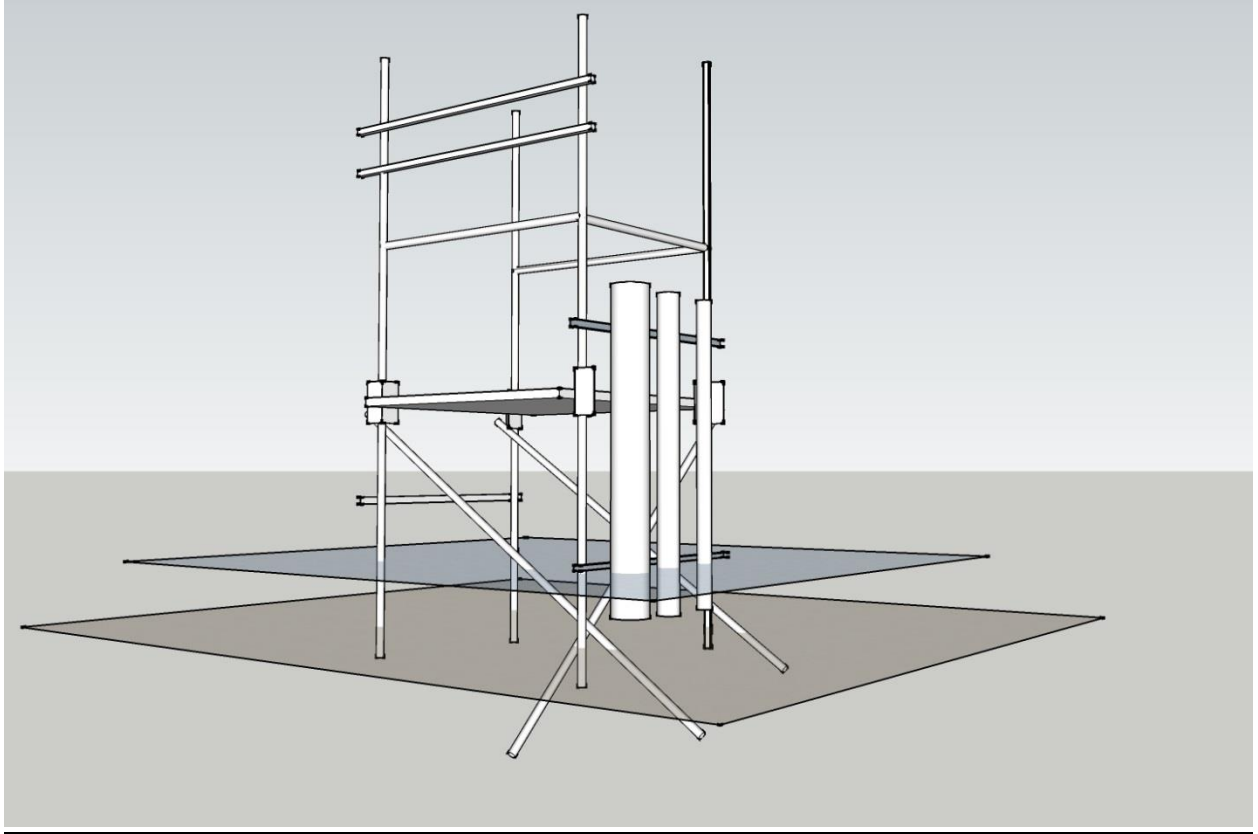

Item 3.2



Item 4



Item 4.1



Item 4.2

**SAMPLE
AGREEMENT
BETWEEN THE
ST. JOHNS RIVER WATER MANAGEMENT DISTRICT
AND**

THIS AGREEMENT is entered into by and between the GOVERNING BOARD of the ST. JOHNS RIVER WATER MANAGEMENT DISTRICT (“the District”), whose address is 4049 Reid Street, Palatka, Florida 32177, and (“Contractor”), whose address is , , . All references to the parties hereto include the parties, their officers, employees, agents, successors, and assigns.

In consideration of the payments hereinafter specified, Contractor agrees to furnish and deliver all materials and perform all labor required for Indian River Lagoon Continuous Monitoring Platforms (“the Work”). Contractor shall complete the Work in conformity with this Agreement, which includes the Statement of Work and any Special Conditions or other attachments. If any provision in the body of this Agreement conflicts with any attachment hereto, the body of this Agreement shall prevail. The parties hereby agree to the following terms and conditions.

1. **TERM.** The term of this Agreement is from the date upon which the last party has dated and executed the same (“Effective Date”) until April 15, 2018 (“Completion Date”). Contractor shall not commence Work until all required submittals are received and approved. Time is of the essence for every aspect of this Agreement, including any time extensions. Notwithstanding specific mention that certain provisions survive termination or expiration of this Agreement, all provisions of this Agreement that by their nature extend beyond the Completion Date survive termination or expiration hereof.

2. **COMMENCEMENT OF WORK.**

Contractor shall commence the Work within fifteen (15) days after the Effective Date. This date shall be known as the “Commencement Date.” Contractor shall prosecute the Work regularly, diligently, and uninterruptedly so as to complete the Work ready for use in accordance with the Statement of Work and the time for completion stated therein. Contractor shall not commence the Work until any required submittals are received and approved.

3. **DELIVERABLES.**

(a) The Work is specified in the Statement of Work, Attachment A. Contractor shall deliver all products and deliverables as stated therein. Contractor is responsible for the professional quality, technical accuracy, and timely completion of the Work. Both workmanship and materials shall be of good quality. Contractor shall, if required, furnish satisfactory evidence as to the kind and quality of materials provided. Unless otherwise specifically provided for herein, Contractor shall provide and pay for all materials, labor, and other facilities and equipment necessary for performance of the Work. The District’s Project Manager shall make a final acceptance inspection of the deliverables when completed and finished in all respects.

(b) If not otherwise addressed in the Statement of Work, upon written request, Contractor shall submit written progress reports to the District’s Project Manager at the frequency requested in the form approved by the Project Manager at no additional cost to the District. The progress report shall provide an updated progress schedule, taking into account all delays and approved changes in the Work. Failure to provide a progress report will be cause to withhold payment.

4. **OWNERSHIP OF DELIVERABLES.** All deliverables, including Work not accepted by the District, are District property when Contractor has received compensation therefor, in whole or in part. Any District source documents or other District or non-District documents, specifications, materials, reports, or accompanying data developed, secured, or used in the performance of the Work, excluding proprietary materials, as outlined in the Statement of Work, are District property and shall be safeguarded and provided to the District upon request. District plans and specifications shall not be used on other work and, with the exception of the original plans and specifications, shall be returned to the District upon request. This obligation shall survive termination or expiration of this Agreement.

5. **FUNDING OF AGREEMENT**

For satisfactory performance of the Work, the District agrees to pay Contractor [a sum not to exceed] [\$_] (the "Total Compensation").

6. **PAYMENT OF INVOICES**

- (a) Contractor shall submit itemized invoices by one of the following two methods: (1) by mail to the St. Johns River Water Management District, Finance Director, 4049 Reid Street, Palatka, Florida 32177, or (2) by e-mail to acctpay@sjrwmd.com. Each invoice shall be submitted in detail sufficient for proper pre-audit and post-audit review. If necessary for audit purposes, Contractor shall provide additional supporting information as required to document invoices.
- (b) **End of District Fiscal Year Reporting.** The District's fiscal year ends on September 30. Irrespective of the invoicing frequency, the District is required to account for all encumbered funds at that time. When authorized under the Agreement, submittal of an invoice as of September 30 satisfies this requirement. The invoice shall be submitted no later than October 30. If the Agreement does not authorize submittal of an invoice as of September 30, Contractor shall submit, prior to October 30, a description of the additional Work completed between the last invoice and September 30, and an estimate of the additional amount due as of September 30 for such Work. If there have been no prior invoices, Contractor shall submit a description of the Work completed on the project through September 30 and a statement estimating the dollar value of that Work as of September 30.
- (c) **Final Invoice.** The final invoice must be submitted no later than 45 days after the Completion Date; provided, however, that when the Completion Date corresponds with the end of the District's fiscal year (September 30), the final invoice must be submitted no later than 30 days after the Completion Date. **Final invoices that are submitted after the requisite date shall be subject to a penalty of 10 percent of the invoice. This penalty may be waived by the District, in its sole judgment and discretion, upon a showing of special circumstances that prevent the timely submittal of the final invoice. Contractor must request approval for delayed submittal of the final invoice not later than ten (10) days prior to the due date and state the basis for the delay.**
- (d) All invoices shall include the following information: (1) District contract number; (2) District encumbrance number; (3) District work-order number, if applicable; (4) Contractor's name and address (include remit address, if necessary); (5) Contractor's invoice number and date of invoice; (6) District Project Manager or Work Order Manager, if applicable; (7) Contractor's Project Manager; (8) supporting documentation as to cost and/or project completion (as per the cost schedule and other requirements of the Statement of Work; for work-orders, see special requirements under **WORK ORDERS**); (9) Progress Report (if required); (10) Diversity Report (if otherwise required herein). Invoices that do not correspond with

this paragraph shall be returned without action, stating the basis for rejection. Payment shall be made within forty-five (45) days of receipt of an approved invoice. Disputes regarding invoice sufficiency are resolved pursuant to the dispute resolution procedure of this Agreement.

- (e) **Travel expenses.** If the cost schedule for this Agreement or project estimate for a Work Order (if applicable) includes a line item for travel expenses, travel expenses shall be drawn from the project budget and are not otherwise compensable. If travel expenses are not included in the cost schedule, they are a cost of providing the service that is borne by Contractor and are only compensable when specifically approved by the District as an authorized District traveler. In such instance, travel expenses must be submitted on District or State of Florida travel forms and shall be paid pursuant to District Administrative Directive 2000-02.
 - (f) **Payments withheld.** The District may withhold or, on account of subsequently discovered evidence, nullify, in whole or in part, any payment to such an extent as may be necessary to protect the District from loss as a result of: (1) defective Work not remedied; (2) failure of Contractor to make payments when due to subcontractors or suppliers for materials or labor; (3) failure to maintain adequate progress in the Work; (4) damage to another contractor; or (5) any other material breach of this Agreement. Amounts withheld shall not be considered due and shall not be paid until the ground(s) for withholding payment have been remedied.
 - (g) **Payments.** The District shall pay Contractor one hundred percent (100%) of each approved invoice.
7. **PAYMENT AND RELEASE.** Upon satisfactory completion of the Work, the District will provide Contractor a written statement accepting all deliverables. Contractor's acceptance of final payment shall constitute a release in full of all Contractor claims against the District arising from the performance of this Agreement, with the exception of any pending claims for additional compensation that have been documented and filed as required by this Agreement.
8. **INDEMNIFICATION.** Contractor shall indemnify and hold harmless, release, and forever discharge the District, its public officers, employees, agents, representatives, successors, and assigns, from any and all liabilities, damages, losses, and costs, including, but not limited to, reasonable attorney's fees, arising from or caused by the Contractor, its employees or subcontractors, in the performance of the Work. The Contractor shall further indemnify the District for all costs and penalties the District incurs related to any failure to offer Patient Protection and Affordable Care Act compliant health care coverage to Contractor-employees performing under this contract.
9. **INSURANCE.** Contractor shall acquire and maintain all insurance required by Attachment B, Insurance Requirements, and shall not commence Work until it has provided Certificates of Insurance to the District as per Attachment B. Receipt of Certificates of Insurance indicating less coverage than required does not constitute a waiver of the Insurance Requirements. Contractor waives its right of recovery against the District to the extent permitted by its insurance policies. Contractor's insurance shall be considered primary, and District insurance shall be considered excess, as may be applicable to Contractor's obligation to provide insurance.
10. **FUNDING CONTINGENCY.** This Agreement is at all times contingent upon funding availability, which may include a single source or multiple sources, including, but not limited to: (1) ad valorem tax revenues appropriated by the District's Governing Board; (2) annual appropriations by the Florida Legislature, or (3) appropriations from other agencies or funding sources. Agreements that extend for a period of more than one Fiscal Year are subject

to annual appropriation of funds in the sole discretion and judgment of the District's Governing Board for each succeeding Fiscal Year. Should the Work not be funded, in whole or in part, in the current Fiscal Year or succeeding Fiscal Years, the District shall so notify Contractor and this Agreement shall be deemed terminated for convenience five (5) days after receipt of such notice, or within such additional time as the District may allow. For the purpose of this Agreement, "Fiscal Year" is defined as the period beginning on October 1 and ending on September 30.

11. PROJECT MANAGEMENT AND PERSONNEL

- (a) The Project Managers listed below shall be responsible for overall coordination and management of the Work. Either party may change its Project Manager upon three (3) business days prior written notice to the other party. Written notice of change of address shall be provided within five (5) business days. All notices shall be in writing to the Project Managers at the addresses below and shall be sent by one of the following methods: (1) hand delivery; (2) U.S. certified mail; (3) national overnight courier; (4) e-mail or, (5) fax. Notices via certified mail are deemed delivered upon receipt. Notices via overnight courier are deemed delivered one (1) business day after having been deposited with the courier. Notices via e-mail or fax are deemed delivered on the date transmitted and received.

<p><u>DISTRICT</u> , Project Manager St. Johns River Water Management District 4049 Reid Street Palatka, Florida 32177 Telephone: E-mail:</p>	<p><u>CONTRACTOR</u> , Project Manager , Telephone: E-mail:</p>
---	---

- (b) The District's Project Manager shall have sole responsibility for transmitting instructions, receiving information, and communicating District policies and decisions regarding all matters pertinent to performance of the Work.
- (c) Contractor shall maintain an adequate and competent professional staff. Contractor's employees, subcontractors, or agents shall be properly trained to meet or exceed any specified licensing, training and/or certification applicable to their profession. Upon request, Contractor shall furnish proof thereof.

12. DELAYS. Contractor shall not be compensated for delays in the Work caused by Contractor's inefficiency, rework made necessary by Contractor's error, failure to perform the Work as scheduled, or any other corrective or productivity measures made necessary by errors, omissions, or failures to properly perform the Work. Within ten (10) days after the onset of a delay, Contractor shall notify the District in writing of the delay, which shall provide: (1) a detailed description the delay and its probable duration, (2) the specified portion of the Work affected, and (3) an opinion as to the cause of the delay and liability (if any) for the delay. Notices provided more than ten (10) days after inception of the delay shall only be effective as to additional costs or delay incurred during the ten (10) day period preceding receipt of such notice. In the case of continuing delay for the same cause, only one notice of delay is necessary. If the delay is due to causes beyond Contractor's control, as determined by the District in its sole judgment and discretion, the District may grant a time extension in the form of a written amendment signed by both parties.

13. AMENDMENTS. The parties may not amend this Agreement except in writing. Modifications that alter, add to, or deduct from the Work, or otherwise modify the terms of this Agreement, shall be implemented through a change order or formal amendment, specifying the nature of the change and any associated change in the Total Compensation

and/or Completion Date. The District's Project Manager may also issue a District Supplemental Instruction (DSI) form (Attachment C) to authorize minor adjustments to the Work that are consistent with the purpose of the Work. Both parties must sign the DSI. A DSI may not be used to change the Total Compensation, quantity, quality or the Completion Date of the Work, or to change or modify the Agreement..

14. **TERMINATION.** The District may terminate this Agreement without cause upon 10 days written notice. In such event Contractor shall be compensated for all Work performed in accordance with this Agreement to the effective date of termination. Alternatively, in the event of any material breach hereof, the District may terminate this Agreement for cause on ten (10) days written notice and opportunity to cure. Upon termination with or without cause, the District may take possession of and finish the Work by whatever means it deems expedient. Contractor may terminate this contract only if the District fails to pay sums when due. In such event, Contractor shall provide the District no less than ten (10) days prior written notice of its intention to terminate and afford the District an opportunity to cure the grounds for termination within said period.

ADDITIONAL PROVISIONS (In Alphabetical Order)

15. **ACCESS.** The District will provide sufficient access to accomplish any Work performed on District property. Land access to the work area shall be restricted to the route designated by the District. Access routes shall be used only for the Work. Contractor shall not disturb lands or waters outside the area of activity, except as authorized by the District. Contractor shall keep all gates to District lands or easements closed and locked in accordance with District specifications when not in use, and shall immediately notify the District when a gate has become impaired due to vandalism or other cause. Contractor shall be responsible for providing lock(s) to District properties, unless otherwise stated in the Statement of Work.
16. **ASSIGNMENT AND SUBCONTRACTS.** Contractor shall not sublet, assign, or transfer any Work, involving more than twenty percent (20%) of the total cost of the Work, or assign any monies due or to become due hereunder, without the District's prior written consent. Neither District approval of a subcontractor nor any other provision of this Agreement creates a contractual relationship between any subcontractor and the District. Contractor is responsible for fulfilling all work elements in any subcontracts and payment of all monies due. Contractor is fully responsible to the District for the acts and omissions of its subcontractors and persons directly or indirectly employed by them, and shall hold the District harmless from any liability or damages resulting from any subcontract to the extent allowed by law.
17. **AUDIT; ACCESS TO RECORDS.** Contractor must preserve its books and other records involving transactions related to this Agreement and provide the District, or its duly authorized representatives, access and necessary facilities to inspect and audit those records for five years after the receipt of funds. If an examination or audit is performed, Contractor must continue to maintain all required records until such audit has been completed and all questions arising from it are resolved. Contractor shall refund any payment(s) that are found to not constitute allowable costs based upon an audit examination.
18. **CIVIL RIGHTS.** Pursuant to chapter 760, Fla. Stat., Contractor shall not discriminate against any employee or applicant for employment because of race, color, religion, sex, or national origin, age, handicap, or marital status.
19. **DISPUTE RESOLUTION.**
 - (a) **During the course of work.** In the event any dispute arises during the course of the Work, Contractor shall fully perform the Work in accordance with the District's

written instructions and may claim additional compensation. Contractor is under a duty to seek clarification and resolution of any issue, discrepancy, or dispute by submitting a formal request for additional compensation, schedule adjustment, or other dispute resolution to the District's Project Manager no later than fifteen (15) calendar days after the precipitating event. If not resolved by the Project Manager within five (5) business days, the Project Manager shall forward the request to the District's Office of General Counsel, which shall issue a written decision within fifteen (15) calendar days of receipt. This determination shall constitute final action of the District and shall then be subject to judicial review upon completion of the Work. **Contractor shall proceed with the Work in accordance with said determination. This shall not waive Contractor's position regarding the matter in dispute.**

- (b) **Invoices.** In the event the District rejects an invoice as improper, and the Contractor declines to modify the invoice, the Contractor must notify the District in writing within ten (10) calendar days of receipt of notice of rejection that the Contractor will not modify the invoice and state the reason(s) therefore. Within five (5) business days of receipt of such notice, if not informally resolved through discussion with the District Project Manager, the Project Manager shall forward the disputed invoice and the Contractor's written response to the District's Office of General Counsel. The matter shall then proceed as described in subsection (a), above.

20. **GOVERNING LAW, VENUE, ATTORNEY'S FEES, WAIVER OF RIGHT TO JURY TRIAL.** This Agreement shall be construed according to the laws of Florida and shall not be construed more strictly against one party than against the other because it may have been drafted by one of the parties. As used herein, "shall" is always mandatory. In the event of any legal proceedings arising from or related to this Agreement: (1) venue for any state or federal legal proceedings shall be in Orange County; (2) each party shall bear its own attorney's fees, including appeals; (3) for civil proceedings, the parties hereby consent to trial by the court and waive the right to jury trial.
21. **INDEPENDENT CONTRACTOR.** Contractor is an independent contractor. Neither Contractor nor Contractor's employees are employees or agents of the District. Contractor controls and directs the means and methods by which the Work is accomplished. Contractor is solely responsible for compliance with all labor, health insurance (Patient Protection and Affordable Care Act 42 U.S.C. §§ 18001, et seq.), and tax laws pertaining to Contractor, its officers, agents, and employees, and shall indemnify and hold the District harmless from any failure to comply with such laws.
22. **INTEREST IN THE BUSINESS OF CONTRACTOR; NON-LOBBYING.** Contractor certifies that no District officer, agent, or employee has any direct or indirect material interest, as defined in chapter 112, Fla. Stat., in Contractor's business under this Agreement, or shall have any such interest during the term hereof. Pursuant to section 216.347, Fla. Stat., monies received from the District under this Agreement shall not be used to lobby the Florida Legislature, the judicial branch, or any state agency.
23. **LAND AND WATER RESOURCES.** Contractor shall not discharge or permit the discharge, directly or indirectly, of any fuels, oils, calcium chloride, acids, insecticides, herbicides, wastes, toxic or hazardous substances, or other pollutants or harmful materials, onto any lands or into any surface or ground waters, including, but not limited to, streams, lakes, rivers, canals, ditches, or reservoirs. Contractor shall investigate and comply with all applicable federal, state, county, and municipal laws concerning toxic wastes, hazardous substances, and pollution of surface and ground waters. If any waste, toxic or hazardous substance, or other material that can cause pollution, as defined in section 403.031, Fla. Stat., is dumped or spilled in unauthorized areas, Contractor shall notify the District thereof within one (1) workday and thereafter shall remove the material and restore the area to its original

condition. If necessary, contaminated ground shall be excavated and disposed of as directed by the District and replaced with suitable fill material, compacted and finished with topsoil, and planted as required to re-establish vegetation. All cleanup and disposal costs shall be borne by Contractor.

24. **COMPLIANCE WITH LAW; PERMITS AND LICENSES.** Contractor shall comply with all applicable federal, state and local laws and regulations, including those pertaining to health and safety. All materials used and work performed must conform to the laws of the United States, the state of Florida and county and municipal ordinances. Contractor represents and warrants that it is duly licensed to perform the Work in accordance with the laws of the state of Florida and the county or municipality in which the Work is to be performed. Unless otherwise specifically provided for herein, Contractor shall give to the proper authorities all required notices relative to the Work in its charge; obtain and pay for all official permits or any other licenses, including any and all professional licenses required by the nature of the Work; and furnish any bonds, security, or deposits required to permit performance of the Work. Contractor is responsible for the resolution of any issues resulting from a finding of noncompliance by any regulatory agencies, due to the Contractor's failure to comply with applicable regulatory requirements, including all costs for delays, litigation, fines, or other costs.

25. **PUBLIC RECORDS.**

- A. Contractor is responsible for identifying confidential trade secret information as such upon submittal to the district. Notwithstanding any other provision hereof, the district shall not be liable to contractor for release of confidential information not identified as such upon submittal. If the district receives a public records request that requests information claimed to be confidential by contractor, the district shall take such steps as are necessary to comply with chapter 119, Fla. Stat., while protecting the confidentiality of trade secret information. In the event of a dispute as to whether the requested information is a trade secret, Contractor shall be liable for all costs incurred by the district resulting from the dispute, including any court costs and attorney's fees. The calculation of those costs shall not include costs that are charged to the public records requestor.
- b. Contractor shall comply with Florida Public Records law under Chapter 119, Fla. Stat. Records made or received in conjunction with this Agreement are public records under Florida law, as defined in §119.011(12), Fla. Stat. Contractor shall keep and maintain public records required by the District to perform the services under this Agreement.
- c. If Contractor meets the definition of "Contractor" found in §119.0701(1)(a), Fla. Stat.; [i.e., an individual, partnership, corporation, or business entity that enters into a contract for services with a public agency and is acting on behalf of the public agency], then the following requirements apply:
 - i. Pursuant to §119.0701, Fla. Stat., a request to inspect or copy public records relating to this Agreement for services must be made directly to the District. If the District does not possess the requested records, the District shall immediately notify the Contractor of the request, and the Contractor must provide the records to the District or allow the records to be inspected or copied within a reasonable time. If Contractor fails to provide the public records to the District within a reasonable time, the Contractor may be subject to penalties under s. 119.10, Fla. Stat.
 - ii. Upon request from the District's custodian of public records, Contractor shall provide the District with a copy of the requested records or allow the records to be inspected or copied within a reasonable time at a cost that does not exceed the cost provided in Chapter 119, Fla. Stat., or as otherwise provided by law.

- iii. Contractor shall identify and ensure that all public records that are exempt or confidential and exempt from public records disclosure requirements are not disclosed except as authorized by law for the duration of the Agreement term and following completion of the Agreement if the Contractor does not transfer the records to the District.
- iv. Upon completion of the Agreement, Contractor shall transfer, at no cost to District, all public records in possession of Contractor or keep and maintain public records required by the District to perform the services under this Agreement. If the Contractor transfers all public records to the District upon completion of the Agreement, the Contractor shall destroy any duplicate public records that are exempt or confidential and exempt from public disclosure requirements. If the Contractor keeps and maintains public records upon completion of the Agreement, the Contractor shall meet all applicable requirements for retaining public records. All records that are stored electronically must be provided to the District, upon request from the District's custodian of public records, in a format that is accessible by and compatible with the information technology systems of the District.

d. IF THE CONTRACTOR HAS QUESTIONS REGARDING THE APPLICATION OF CHAPTER 119, FLA. STAT., TO THE CONTRACTOR'S DUTY TO PROVIDE PUBLIC RECORDS RELATING TO THIS CONTRACT, CONTACT THE DISTRICT'S CUSTODIAN OF PUBLIC RECORDS AT:

**District Clerk
St. Johns River Water Management District
4049 Reid Street
Palatka, Florida 32177-2571
(386) 329-4127
clerk@sjrwmd.com**

- 26. **SAFETY.** For any Work that is to be performed on premises that are owned or controlled by the District (the Premises), Contractor has the sole and exclusive duty for the safety of the premises. Contractor shall provide and maintain sufficient protection for the safety of its employees and other persons who may utilize the Premises, and prevent damage to District property, materials, and equipment. Contractor shall at all times enforce strict discipline and good order among its employees and shall not employ any unfit person or anyone not skilled in the work assigned. Neither Contractor nor its subcontractors shall allow or cause to be allowed any hunting or any weapons, animals, alcohol, or drugs, on or from the Premises or adjacent property. Contractor employees shall not park their vehicles or store equipment or materials adjacent to roads where it may be a hazard to traffic. A clear distance of at least 30 feet from the edge of the pavement or right-of-way shall be kept free of any obstacles unless otherwise authorized by the District. Contractor shall ensure that only authorized personnel are allowed on the worksite and shall post notices warning both employees and the public of all safety hazards created by Contractor.
- 27. **WORK SCHEDULE.** For construction or other services upon District property, no Work shall be accomplished on official holidays or weekends unless approved in advance by the District Project Manager. Unless otherwise approved by the District Project Manager, Contractor's work hours on District property shall not commence before 7:00 a.m. and shall conclude on or before 6:00 p.m. All requests to change the schedule shall be coordinated with the District a minimum of 24 hours in advance of the change and confirmed in writing.

IN WITNESS WHEREOF, the St. Johns River Water Management District has caused this Agreement to be executed on the day and year written below in its name by its Executive Director, or duly authorized designee, and Contractor has caused this Agreement to be executed on the day and year written below in its name by its duly authorized representatives, and, if appropriate, has caused the seal of the corporation to be attached. This Agreement may be executed in separate counterparts, which shall not affect its validity. Upon execution, this Agreement constitutes the entire agreement of the parties, notwithstanding any stipulations, representations, agreements, or promises, oral or otherwise, not printed or inserted herein. This Agreement cannot be changed by any means other than written amendments referencing this Agreement and signed by all parties.

ST. JOHNS RIVER WATER
MANAGEMENT DISTRICT

CONTRACTOR

By: _____
Ann B. Shortelle, Ph.D., Executive Director (or designee)

By: _____

Typed Name and Title

Date: _____

Date: _____

Attest: _____

Typed Name and Title

- Attachment A: Statement of Work/Technical Specifications
- Attachment B: Insurance Requirements
- Attachment C: District's Supplemental Instructions (sample)

ATTACHMENT 4 — INSURANCE

Consultant shall acquire and maintain until completion of the Work the insurance coverage listed below, which constitutes primary coverage. Consultant shall not commence the Work until the District receives and approves Certificates of Insurance documenting required coverage. Consultant's General Liability policy shall name the St. Johns River Water Management District (the "District") as Additional Insured. All required policies shall include: (1) endorsement that waives any right of subrogation against the District for any policy of insurance provided under this requirement or under any state or federal worker's compensation or employer's liability act; (2) endorsement to give the District no less than 30 days notice in the event of cancellation or material change. Certificates of Insurance must be accompanied by copies of the requested endorsements.

Any deductibles or self-insured retentions above \$100,000 must be declared to and approved by the District. Approval will not be unreasonably withheld. Consultant is responsible for any deductible or self-insured retention. Insurance must be placed with insurers having an A.M. Best rating of A-V or greater. District receipt of insurance certificates providing less than the required coverage does not waive these insurance requirements.

- (a) **Workers' Compensation Insurance.** Workers' compensation and employer's liability coverage, including maritime workers compensation, if applicable, in not less than the minimum limits required by Florida law. If Contractor claims an exemption from workers' compensation coverage, Contractor must provide a copy of the Certificate of Exemption from the Florida Division of Workers' Compensation for all officers or members of an LLC claiming exemption who will be participating in the Work. In addition, Contractor must provide a completed District "Affidavit (Non-Construction)" for non-construction contracts. Contractor is solely responsible for compliance with any Federal workers' compensation laws such as Jones Act and USL&H Act, including any benefits available to any workers performing work on this project.
- (b) **General Liability.** Commercial General Liability Insurance on an "Occurrence Basis," with limits of liability not less than \$500,000 for personal injury, bodily injury, and property damage. Coverage shall include: (1) contractual liability, (2) products and completed operations, (3) independent contractors, and (4) property in the care, control, or custody of Contractor. Extensions shall be added or exclusions deleted to provide the necessary coverage.
- (c) **Automobile Liability.** Minimum requirements per Florida law.