



COVER SHEET

Proposal Submitted By:

Contractor's Name

Contractor's Address

City

State

Zip Code

STATE OF ILLINOIS

Local Public Agency

County

Section Number

Village of Buffalo Grove

Lake

N/A

Route(s) (Street/Road Name)

Type of Funds

Parking Lot Repairs

Local

Proposal Only Proposal and Plans Proposal only, plans are separate

Submitted/Approved
For Local Public Agency:

For a County and Road District Project

Submitted/Approved

Highway Commissioner Signature Date

Submitted/Approved

County Engineer/Superintendent of Highways Date

For a Municipal Project

Submitted/Approved/Passed

Signature Date

Official Title

Civil Engineer II

Department of Transportation

Released for bid based on limited review

Regional Engineer Signature Date

Note: All proposal documents, including Proposal Guaranty Checks or Proposal Bid Bonds, should be stapled together to prevent loss when bids are processed.

Local Public Agency	County	Section Number	Route(s) (Street/Road Name)
Village of Buffalo Grove	Lake	N/A	Parking Lot Repairs

NOTICE TO BIDDERS

Sealed proposals for the project described below will be received at the office of www.vbg.org/bids

Address	Name of Office	until 9:30 AM	on 03/09/23
		Time	Date

Sealed proposals will be opened and read publicly at the office of Microsoft Teams Meeting: <https://bit.ly/3k6VRgQ>

Address	Name of Office	at 9:30 AM	on 03/09/23
		Time	Date

DESCRIPTION OF WORK

Location	Project Length
Police Department & Fire Station 25 Parking Lot Repairs	N/A

Proposed Improvement

This project includes, but is not limited to, Class B & D patching and any other work necessary to complete pavement repairs at the Police Department parking lot and Fire Station 25 parking lot and driveway. All work shall be performed in accordance with the Illinois Department of Transportation (IDOT) Standard Specifications for Road and Bridge Construction, edition in effect at the time of the bid.

1. Plans and proposal forms will be available in the office of

www.vbg.org/bids
Office of the Purchasing Manager - (847) 459-2500

2. Prequalification

If checked, the 2 apparent as read low bidders must file within 24 hours after the letting an "Affidavit of Availability" (Form BC 57) in triplicate, showing all uncompleted contracts awarded to them and all low bids pending award for Federal, State, County, Municipal and private work. One original shall be filed with the Awarding Authority and two originals with the IDOT District Office.

3. The Awarding Authority reserves the right to waive technicalities and to reject any or all proposals as provided in BLRS Special Provision for Bidding Requirements and Conditions for Contract Proposals.

4. The following BLR Forms shall be returned by the bidder to the Awarding Authority:

- a. Local Public Agency Formal Contract Proposal (BLR 12200)
- b. Schedule of Prices (BLR 12201)
- c. Proposal Bid Bond (BLR 12230) (if applicable)
- d. Apprenticeship or Training Program Certification (BLR 12325) (do not use for project with Federal funds.)
- e. Affidavit of Illinois Business Office (BLR 12326) (do not use for project with Federal funds)

5. The quantities appearing in the bid schedule are approximate and are prepared for the comparison of bids. Payment to the Contractor will be made only for the actual quantities of work performed and accepted or materials furnished according to the contract. The scheduled quantities of work to be done and materials to be furnished may be increased, decreased or omitted as hereinafter provided.

6. Submission of a bid shall be conclusive assurance and warranty the bidder has examined the plans and understands all requirements for the performance of work. The bidder will be responsible for all errors in the proposal resulting from failure or neglect to conduct an in depth examination. The Awarding Authority will, in no case, be responsible for any costs, expenses, losses or changes in anticipated profits resulting from such failure or neglect of the bidder.

7. The bidder shall take no advantage of any error or omission in the proposal and advertised contract.

8. If a special envelope is supplied by the Awarding Authority, each proposal should be submitted in that envelope furnished by the Awarding Agency and the blank spaces on the envelope shall be filled in correctly to clearly indicate its contents. When an envelope other than the special one furnished by the Awarding Authority is used, it shall be marked to clearly indicate its contents. When sent by mail, the sealed proposal shall be addressed to the Awarding Authority at the address and in care of the official in whose office the bids are to be received. All proposals shall be filed prior to the time and at the place specified in the Notice to Bidders. Proposals received after the time specified will be returned to the bidder unopened.

9. Permission will be given to a bidder to withdraw a proposal if the bidder makes the request in writing or in person before the time for opening proposals.

Local Public Agency	County	Section Number	Route(s) (Street/Road Name)
Village of Buffalo Grove	Lake	N/A	Parking Lot Repairs

PROPOSAL

1. Proposal of _____ Contractor's Name _____

Contractor's Address _____

2. The plans for the proposed work are those prepared by Village of Buffalo Grove and approved by the Department of Transportation on N/A.

3. The specifications referred to herein are those prepared by the Department of Transportation and designated as "Standard Specifications for Road and Bridge Construction" and the " Supplemental Specifications and Recurring Special Provisions" thereto, adopted and in effect on the date of invitation for bids.

4. The undersigned agrees to accept, as part of the contract, the applicable Special Provisions indicated on the "Check Sheet for Recurring Special Provisions" contained in this proposal.

5. The undersigned agrees to complete the work within _____ working days or by 07/28/23 unless additional time is granted in accordance with the specifications.

6. The successful bidder at the time of execution of the contract Will be required to deposit a contract bond for the full amount of the award. When a contract bond is not required, the proposal guaranty check will be held in lieu thereof. If this proposal is accepted and the undersigned fails to execute a contract and contract bond as required, it is hereby agreed that the Bid Bond of check shall be forfeited to the Awarding Authority.

7. Each pay item should have a unit price and a total price. If no total price is shown or if there is a discrepancy between the products of the unit price multiplied by the quantity, the unit price shall govern. If a unit price is omitted, the total price will be divided by the quantity in order to establish a unit price. A bid may be declared unacceptable if neither a unit price nor a total price is shown.

8. The undersigned submits herewith the schedule of prices on BLR 12201 covering the work to be performed under this contract.

9. The undersigned further agrees that if awarded the contract for the sections contained in the combinations on BLR 12201, the work shall be in accordance with the requirements of each individual proposal for the multiple bid specified in the Schedule for Multiple Bids below.

10. A proposal guaranty in the proper amount, as specified in BLRS Special Provision for Bidding Requirements and Conditions for Contract Proposals, will be required. Bid Bonds Will be allowed as a proposal guaranty. Accompanying this proposal is either a bid bond, if allowed, on Department form BLR 12230 or a proposal guaranty check, complying with the specifications, made payable to: _____ Treasurer of Buffalo Grove.

The amount of the check is Bid Bond (5% of Total Bid) (_____).

Attach Cashier's Check or Certified Check Here

In the event that one proposal guaranty check is intended to cover two or more bid proposals, the amount must be equal to the sum of the proposal guaranties which would be required for each individual bid proposal. If the proposal guaranty check is placed in another bid proposal, state below where it may be found.

The proposal guaranty check will be found in the bid proposal for: Section Number _____.

Local Public Agency	County	Section Number	Route(s) (Street/Road Name)
Village of Buffalo Grove	Lake	N/A	Parking Lot Repairs

CONTRACTOR CERTIFICATIONS

The certifications hereinafter made by the bidder are each a material representation of fact upon which reliance is placed should the Department enter into the contract with the bidder.

- Debt Delinquency.** The bidder or contractor or subcontractor, respectively, certifies that it is not delinquent in the payment of any tax administered by the Department of Revenue unless the individual or other entity is contesting, in accordance with the procedure established by the appropriate Revenue Act, its liability for the tax or the amount of the tax. Making a false statement voids the contract and allows the Department to recover all amounts paid to the individual or entity under the contract in a civil action.
- Bid-Rigging or Bid Rotating.** The bidder or contractor or subcontractor, respectively, certifies that it is not barred from contracting with the Department by reason of a violation of either 720 ILCS 5/33E-3 or 720 ILCS 5/33E-4.

A violation of section 33E-3 would be represented by a conviction of the crime of bid-rigging which, in addition to Class 3 felony sentencing, provides that any person convicted of this offense, or any similar offense of any state or the United States which contains the same elements as this offense shall be barred for 5 years from the date of conviction from contracting with any unit of State or local government. No corporation shall be barred from contracting with any unit of State or local government as a result of a conviction under this Section of any employee or agent of such corporation if the employee so convicted is no longer employed by the corporation: (1) it has been finally adjudicated not guilty or (2) if it demonstrates to the governmental entity with which it seeks to contract that entity finds that the commission of the offense was neither authorized, requested, commanded, nor performed by a director, officer or a high managerial agent on behalf of the corporation.

A violation of Section 33E-4 would be represented by a conviction of the crime of bid-rotating which, in addition to Class 2 felony sentencing, provides that any person convicted of this offense or any similar offense of any state or the United States which contains the same elements as this offense shall be permanently barred from contracting with any unit of State of Local government. No corporation shall be barred from contracting with any unit of State or Local government as a result of a conviction under this Section of any employee or agent of such corporation if the employee so convicted is no longer employed by the corporation and: (1) it has been finally adjudicated not guilty or (2) if it demonstrates to the governmental entity with which it seeks to contract and that entity finds that the commission of the offense was neither authorized, requested, commanded, nor performed by a director, officer or a high managerial agent on behalf of the corporation.

- Bribery.** The bidder or contractor or subcontractor, respectively, certifies that, it has not been convicted of bribery or attempting to bribe an officer or employee of the State of Illinois or any unit of local government, nor has the firm made an admission of guilt of such conduct which is a matter or record, nor has an official, agent, or employee of the firm committed bribery or attempted bribery on behalf of the firm and pursuant to the direction or authorization of a responsible official of the firm.
- Interim Suspension or Suspension.** The bidder or contractor or subcontractor, respectively, certifies that it is not currently under a suspension as defined in Subpart I of Title 44 Subtitle A Chapter III Part 6 of the Illinois Administrative code. Furthermore, if suspended prior to completion of this work, the contract or contracts executed for the completion of this work may be canceled.

Local Public Agency	County	Section Number	Route(s) (Street/Road Name)
Village of Buffalo Grove	Lake	N/A	Parking Lot Repairs

SIGNATURES

(If an individual)

Signature of Bidder	Date	
<input type="text"/>	<input type="text"/>	
Business Address		
<input type="text"/>		
City	State	Zip Code
<input type="text"/>	<input type="text"/>	<input type="text"/>

(If a partnership)

Firm Name		
<input type="text"/>		
Signature	Date	
<input type="text"/>	<input type="text"/>	
Title		
<input type="text"/>		
Business Address		
<input type="text"/>		
City	State	Zip Code
<input type="text"/>	<input type="text"/>	<input type="text"/>

Insert the Names and Addresses of all Partners

<input type="text"/>

(If a corporation)

Corporate Name		
<input type="text"/>		
Signature	Date	
<input type="text"/>	<input type="text"/>	
Title		
<input type="text"/>		
Business Address		
<input type="text"/>		
City	State	Zip Code
<input type="text"/>	<input type="text"/>	<input type="text"/>

Insert Names of Officers

President
<input type="text"/>

Attest:

Secretary

Secretary

Treasurer

Schedule of Prices

Contractor's Name

Contractor's Address

City

State

Zip Code

Local Public Agency

County

Section Number

Route(s) (Street/Road Name)

Schedule for Multiple Bids

Combination Letter	Section Included in Combinations	Total

Schedule for Single Bid

(For complete information covering these items, see plans and specifications.)

Item Number	Items	Unit	Quantity	Unit Price	Total
	Base Bid				
67100100	Mobilization	LSUM	1		
44200929	Class B Patches, Type I, 8 inch	SQYD	4		
44200934	Class B Patches, Type II, 8 inch	SQYD	39		
44200942	Class B Patches, Type III, 8 inc	SQYD	17		
44200944	Class B Patches, Type IV, 8 inc	SQYD	36		
44201713	Class D Patches, Type I, 6 inch	SQYD	4		
44201717	Class D Patches, Type II, 6 inch	SQYD	59		
44201721	Class D Patches, Type III, 6 inc	SQYD	54		
44201723	Class D Patches, Type IV, 6 inc	SQYD	173		
78001100	Paint Pvmnt Mrkng - Ltrs & Sym	SQFT	12.4		
78001110	Paint Pvmnt Mrkng - Line 4"	FOOT	1884		
44000300	Curb Removal	FOOT	25		
60600605	Concrete Curb, Type B	FOOT	25		
	Alternate Bid				
LR403400	Bituminous Materials (Cover	TON			
	and Seal Coats)				
Bidder's Total Proposal					

- Each pay item should have a unit price and a total price.
- If no total price is shown or if there is a discrepancy between the product of the unit price multiplied by the quantity, the unit price shall govern.
- If a unit price is omitted, the total price will be divided by the quantity in order to establish a unit price.
- A bid may be declared unacceptable if neither a unit price or total price is shown.



Local Public Agency Proposal Bid Bond



Local Public Agency Village of Buffalo Grove	County Lake	Section Number N/A
---	----------------	-----------------------

WE, _____ as PRINCIPAL, and _____ as SURETY, are held jointly, severally and firmly bound unto the above Local Public Agency (hereafter referred to as "LPA") in the penal sum of 5% of the total bid price, or for the amount specified in the proposal documents in effect on the date of invitation for bids, whichever is the lesser sum. We bind ourselves, our heirs, executors, administrators, successors, and assigns, jointly pay to the LPA this sum under the conditions of this instrument.

WHEREAS THE CONDITION OF THE FOREGOING OBLIGATION IS SUCH that, the said PRINCIPAL is submitting a written proposal to the LPA acting through its awarding authority for the construction of the work designated as the above section.

THEREFORE if the proposal is accepted and a contract awarded to the PRINCIPAL by the LPA for the above designated section and the PRINCIPAL shall within fifteen (15) days after award enter into a formal contract, furnish surety guaranteeing the faithful performance of the work, and furnish evidence of the required insurance coverage, all as provided in the "Standard Specifications for Road and Bridge Construction" and applicable Supplemental Specifications, then this obligation shall become void; otherwise it shall remain in full force and effect.

IN THE EVENT the LPA determines the PRINCIPAL has failed to enter into a formal contract in compliance with any requirements set forth in the preceding paragraph, then the LPA acting through its awarding authority shall immediately be entitled to recover the full penal sum set out above, together with all court costs, all attorney fees, and any other expense of recovery.

IN TESTIMONY WHEREOF, the said PRINCIPAL and the said SURETY have caused this instrument to be signed by their respective officers this _____ of _____ Day Month and Year

Principal

Company Name

Signature Date

By:

Title

Company Name

Signature Date

By:

Title

(If Principal is a joint venture of two or more contractors, the company names, and authorized signatures of each contractor must be affixed.)

Surety

Name of Surety

Signature of Attorney-in-Fact Date

By:

STATE OF IL
 COUNTY OF

I _____, a Notary Public in and for said county do hereby certify that

(Insert names of individuals signing on behalf of PRINCIPAL & SURETY)

who are each personally known to me to be the same persons whose names are subscribed to the foregoing instrument on behalf of PRINCIPAL and SURETY, appeared before me this day in person and acknowledged respectively, that they signed and delivered said instruments as their free and voluntary act for the uses and purposes therein set forth.

Given under my hand and notarial seal this _____ day of _____ Month and Year .

(SEAL)

Notary Public Signature

Date commission expires _____

Local Public Agency

County

Section Number

Village of Buffalo Grove

Lake

N/A

ELECTRONIC BID BOND

Electronic bid bond is allowed (box must be checked by LPA if electronic bid bond is allowed)

The Principal may submit an electronic bid bond, in lieu of completing the above section of the Proposal Bid Bond Form. By providing an electronic bid bond ID code and signing below, the Principal is ensuring the identified electronic bid bond has been executed and the Principal and Surety are firmly bound unto the LPA under the conditions of the bid bond as shown above. (If PRINCIPAL is a joint venture of two or more contractors, an electronic bid bond ID code, company/Bidder name title and date must be affixed for each contractor in the venture.)

Electronic Bid Bond ID Code

--	--	--	--	--	--	--	--	--	--	--	--	--	--	--

Company/Bidder Name

--

Signature

--

Date

--

Title

--



Apprenticeship and Training Program Certification



Local Public Agency	County	Street Name/Road Name	Section Number
Village of Buffalo Grove	Lake	Parking Lot Repairs	N/A

All contractors are required to complete the following certification

- For this contract proposal or for all bidding groups in this deliver and install proposal.
- For the following deliver and install bidding groups in this material proposal.

Illinois Department of Transportation policy, adopted in accordance with the provisions of the Illinois Highway Code, requires this contract to be awarded to the lowest responsive and responsible bidder. The award decision is subject to approval by the Department. In addition to all other responsibility factors, this contract or deliver and install proposal requires all bidders and all bidder's subcontractors to disclose participation in apprenticeship or training programs that are (1) approved by and registered with the United States Department of Labor's Bureau of Apprenticeship and Training, and (2) applicable to the work of the above indicated proposals or groups. Therefore, all bidders are required to complete the following certification:

1. Except as provided in paragraph 4 below, the undersigned bidder certifies that it is a participant, either as an individual or as part of a group program, in an approved apprenticeship or training program applicable to each type of work or craft that the bidder will perform with its own employees.
2. The undersigned bidder further certifies, for work to be performed by subcontract, that each of its subcontractors either (A) is, at the time of such bid, participating in an approved, applicable apprenticeship or training program; or (B) will, prior to commencement of performance of work pursuant to this contract, establish participation in an approved apprenticeship or training program applicable to the work of the subcontract.
3. The undersigned bidder, by inclusion in the list in the space below, certifies the official name of each program sponsor holding the Certificate of Registration for all of the types of work or crafts in which the bidder is a participant and that will be performed with the bidder's employees. Types of work or craft that will be subcontracted shall be included and listed as subcontract work. The list shall also indicate any type of work or craft job category for which there is no applicable apprenticeship or training program available.

4. Except for any work identified above, if any bidder or subcontractor shall perform all or part of the work of the contract or deliver and install proposal solely by individual owners, partners or members and not by employees to whom the payment of prevailing rates of wages would be required, check the following box, and identify the owner/operator workforces and positions of ownership.

The requirements of this certification and disclosure are a material part of the contract, and the contractor shall require this certification provision to be included in all approved subcontracts. The bidder is responsible for making a complete report and shall make certain that each type of work or craft job category that will be utilized on the project is accounted for and listed. The Department at any time before or afterward may require the production of a copy of each applicable Certificate of Registration issued by the United States Department of Labor evidencing such participation by the contractor and any or all of its subcontractors. In order to fulfill the participation requirement, it shall not be necessary that any applicable program sponsor be currently taking or that it will take applications for apprenticeship, training or employment during the performance of the work of this contract or deliver and install proposal.

Bidder	Signature	Date	
<div style="border: 1px solid black; height: 20px;"></div>	<div style="border: 1px solid black; height: 40px;"></div>	<div style="border: 1px solid black; height: 40px;"></div>	
Title			
<div style="border: 1px solid black; height: 20px;"></div>			
Address	City	State	Zip Code
<div style="border: 1px solid black; height: 20px;"></div>	<div style="border: 1px solid black; height: 20px;"></div>	<div style="border: 1px solid black; height: 20px;"></div>	<div style="border: 1px solid black; height: 20px;"></div>



Affidavit of Illinois Business Office



Local Public Agency	County	Street Name/Road Name	Section Number
Village of Buffalo Grove	Lake	Parking Lot Repairs	N/A

I, _____ of _____, _____,
Name of Affiant City of Affiant State of Affiant

being first duly sworn upon oath, state as follows:

1. That I am the _____ of _____.
Officer or Position Bidder
2. That I have personal knowledge of the facts herein stated.
3. That, if selected under the proposal described above, _____, will maintain a business office in the
Bidder
 State of Illinois, which will be located in _____ County, Illinois.
County
4. That this business office will serve as the primary place of employment for any persons employed in the construction contemplated by this proposal.
5. That this Affidavit is given as a requirement of state law as provided in Section 30-22(8) of the Illinois Procurement Code.

Signature	Date
Print Name of Affiant	

Notary Public

State of IL

County _____

Signed (or subscribed or attested) before me on _____ by
(date)

_____, authorized agent(s) of
(name/s of person/s)

Bidder

(SEAL)

Signature of Notary Public

My commission expires _____



Affidavit of Availability
For the Letting of



Bureau of Construction
2300 South Dirksen Parkway/Room 322
Springfield, IL 62764

Instructions: Complete this form by either typing or using black ink. "Authorization to Bid" will not be issued unless both sides of this form are completed in detail. Use additional forms as needed to list all work.

Part I. Work Under Contract

List below all work you have under contract as either a prime contractor or a subcontractor. It is required to include all pending low bids not yet awarded or rejected. In a joint venture, list only that portion of the work which is the responsibility of your company. The uncompleted dollar value is to be based upon the most recent engineer's or owners estimate, and must include work subcontracted to others. If no work is contracted, show NONE.

	1	2	3	4	Awards Pending	Accumulated Totals
Contract Number						
Contract With						
Estimated Completion Date						
Total Contract Price						
Uncompleted Dollar Value if Firm is the Prime Contractor						
Uncompleted Dollar Value if Firm is the Subcontractor						
Total Value of All Work						

Part II. Awards Pending and Uncompleted Work to be done with your own forces.

List below the uncompleted dollar value of work for each contract and awards pending to be completed with your own forces. All work subcontracted to others will be listed on the reverse of this form. In a joint venture, list only that portion of the work to be done by your company. If no work is contracted, show NONE.

Earthwork						
Portland Cement Concrete Paving						
HMA Plant Mix						
HMA Paving						
Clean & Seal Cracks/Joints						
Aggregate Bases, Surfaces						
Highway, R.R., Waterway Struc.						
Drainage						
Electrical						
Cover and Seal Coats						
Concrete Construction						
Landscaping						
Fencing						
Guardrail						
Painting						
Signing						
Cold Milling, Planning, Rotomilling						
Demolition						
Pavement Markings (Paint)						
Other Construction (List)						
Totals						

Disclosure of this information is REQUIRED to accomplish the statutory purpose as outlined in the "Illinois Procurement Code." Failure to comply will result in non-issuance of an "Authorization To Bid." This form has been approved by the State Forms Management Center.

Part III. Work Subcontracted to Others.

For each contract described in Part I, list all the work you have subcontracted to others.

	1	2	3	4	Awards Pending
Subcontractor					
Type of Work					
Subcontract Price					
Amount Uncompleted					
Subcontractor					
Type of Work					
Subcontract Price					
Amount Uncompleted					
Subcontractor					
Type of Work					
Subcontract Price					
Amount Uncompleted					
Subcontractor					
Type of Work					
Subcontract Price					
Amount Uncompleted					
Subcontractor					
Type of Work					
Subcontract Price					
Amount Uncompleted					
Total Uncompleted					

Notary

I, being duly sworn, do hereby declare this affidavit is a true and correct statement relating to ALL uncompleted contracts of the undersigned for Federal, State, County, City and private work, including ALL subcontract work, ALL pending low bids not yet awarded or rejected and ALL estimated completion dates.

Officer or Director

Title

Signature

Date

Company

Address

City

State

Zip Code

Subscribed and sworn to before me

this _____ day of _____, _____

(Signature of Notary Public)

My commission expires _____

(Notary Seal)

Add pages for additional contracts



Affidavit of Availability

For the Letting of

Bureau of Construction
 2300 South Dirksen Parkway/Room 322
 Springfield, IL 62764

Instructions: Complete this form by either typing or using black ink. "Authorization to Bid" will not be issued unless both sides of this form are completed in detail. Use additional forms as needed to list all work.

Part I. Work Under Contract

List below all work you have under contract as either a prime contractor or a subcontractor. It is required to include all pending low bids not yet awarded or rejected. In a joint venture, list only that portion of the work which is the responsibility of your company. The uncompleted dollar value is to be based upon the most recent engineer's or owners estimate, and must include work subcontracted to others. If no work is contracted, show NONE.

	1	2	3	4	Awards Pending	Accumulated Totals
Contract Number						
Contract With						
Estimated Completion Date						
Total Contract Price						
Uncompleted Dollar Value if Firm is the Prime Contractor						
Uncompleted Dollar Value if Firm is the Subcontractor						
Total Value of All Work						

Part II. Awards Pending and Uncompleted Work to be done with your own forces.

List below the uncompleted dollar value of work for each contract and awards pending to be completed with your own forces. All work subcontracted to others will be listed on the reverse of this form. In a joint venture, list only that portion of the work to be done by your company. If no work is contracted, show NONE.

Earthwork						
Portland Cement Concrete Paving						
HMA Plant Mix						
HMA Paving						
Clean & Seal Cracks/Joints						
Aggregate Bases, Surfaces						
Highway, R.R., Waterway Struc.						
Drainage						
Electrical						
Cover and Seal Coats						
Concrete Construction						
Landscaping						
Fencing						
Guardrail						
Painting						
Signing						
Cold Milling, Planning, Rotomilling						
Demolition						
Pavement Markings (Paint)						
Other Construction (List)						
Totals						

Disclosure of this information is REQUIRED to accomplish the statutory purpose as outlined in the "Illinois Procurement Code." Failure to comply will result in non-issuance of an "Authorization To Bid." This form has been approved by the State Forms Management Center.

Part III. Work Subcontracted to Others.

For each contract described in Part I, list all the work you have subcontracted to others.

	2	3	4	Awards Pending	1
Subcontractor					
Type of Work					
Subcontract Price					
Amount Uncompleted					
Subcontractor					
Type of Work					
Subcontract Price					
Amount Uncompleted					
Subcontractor					
Type of Work					
Subcontract Price					
Amount Uncompleted					
Subcontractor					
Type of Work					
Subcontract Price					
Amount Uncompleted					
Subcontractor					
Type of Work					
Subcontract Price					
Amount Uncompleted					
Total Uncompleted					

Notary

I, being duly sworn, do hereby declare this affidavit is a true and correct statement relating to ALL uncompleted contracts of the undersigned for Federal, State, County, City and private work, including ALL subcontract work, ALL pending low bids not yet awarded or rejected and ALL estimated completion dates.

Officer or Director

Title

Signature

Date

Company

Address

City

State

Zip Code

Subscribed and sworn to before me
this _____ day of _____, _____

(Signature of Notary Public)

My commission expires _____

(Notary Seal)

Add pages for additional contracts



Affidavit of Availability

For the Letting of

Bureau of Construction
2300 South Dirksen Parkway/Room 322
Springfield, IL 62764

Instructions: Complete this form by either typing or using black ink. "Authorization to Bid" will not be issued unless both sides of this form are completed in detail. Use additional forms as needed to list all work.

Part I. Work Under Contract

List below all work you have under contract as either a prime contractor or a subcontractor. It is required to include all pending low bids not yet awarded or rejected. In a joint venture, list only that portion of the work which is the responsibility of your company. The uncompleted dollar value is to be based upon the most recent engineer's or owners estimate, and must include work subcontracted to others. If no work is contracted, show NONE.

	1	2	3	4	Awards Pending	Accumulated Totals
Contract Number						
Contract With						
Estimated Completion Date						
Total Contract Price						
Uncompleted Dollar Value if Firm is the Prime Contractor						
Uncompleted Dollar Value if Firm is the Subcontractor						
Total Value of All Work						

Part II. Awards Pending and Uncompleted Work to be done with your own forces.

List below the uncompleted dollar value of work for each contract and awards pending to be completed with your own forces. All work subcontracted to others will be listed on the reverse of this form. In a joint venture, list only that portion of the work to be done by your company. If no work is contracted, show NONE.

Earthwork						
Portland Cement Concrete Paving						
HMA Plant Mix						
HMA Paving						
Clean & Seal Cracks/Joints						
Aggregate Bases, Surfaces						
Highway, R.R., Waterway Struc.						
Drainage						
Electrical						
Cover and Seal Coats						
Concrete Construction						
Landscaping						
Fencing						
Guardrail						
Painting						
Signing						
Cold Milling, Planning, Rotomilling						
Demolition						
Pavement Markings (Paint)						
Other Construction (List)						
Totals						

Disclosure of this information is REQUIRED to accomplish the statutory purpose as outlined in the "Illinois Procurement Code." Failure to comply will result in non-issuance of an "Authorization To Bid." This form has been approved by the State Forms Management Center.

Part III. Work Subcontracted to Others.

For each contract described in Part I, list all the work you have subcontracted to others.

	1	2	3	4	Awards Pending
Subcontractor					
Type of Work					
Subcontract Price					
Amount Uncompleted					
Subcontractor					
Type of Work					
Subcontract Price					
Amount Uncompleted					
Subcontractor					
Type of Work					
Subcontract Price					
Amount Uncompleted					
Subcontractor					
Type of Work					
Subcontract Price					
Amount Uncompleted					
Subcontractor					
Type of Work					
Subcontract Price					
Amount Uncompleted					
Total Uncompleted					

Notary

I, being duly sworn, do hereby declare this affidavit is a true and correct statement relating to ALL uncompleted contracts of the undersigned for Federal, State, County, City and private work, including ALL subcontract work, ALL pending low bids not yet awarded or rejected and ALL estimated completion dates.

Officer or Director

Title

Signature

Date

Company

Address

City

State

Zip Code

Subscribed and sworn to before me
this _____ day of _____, _____

(Signature of Notary Public)

My commission expires _____

(Notary Seal)

Add pages for additional contracts



Affidavit of Availability

For the Letting of

Bureau of Construction
2300 South Dirksen Parkway/Room 322
Springfield, IL 62764

Instructions: Complete this form by either typing or using black ink. "Authorization to Bid" will not be issued unless both sides of this form are completed in detail. Use additional forms as needed to list all work.

Part I. Work Under Contract

List below all work you have under contract as either a prime contractor or a subcontractor. It is required to include all pending low bids not yet awarded or rejected. In a joint venture, list only that portion of the work which is the responsibility of your company. The uncompleted dollar value is to be based upon the most recent engineer's or owners estimate, and must include work subcontracted to others. If no work is contracted, show NONE.

	1	2	3	4	Awards Pending	Accumulated Totals
Contract Number						
Contract With						
Estimated Completion Date						
Total Contract Price						
Uncompleted Dollar Value if Firm is the Prime Contractor						
Uncompleted Dollar Value if Firm is the Subcontractor						
Total Value of All Work						

Part II. Awards Pending and Uncompleted Work to be done with your own forces.

List below the uncompleted dollar value of work for each contract and awards pending to be completed with your own forces. All work subcontracted to others will be listed on the reverse of this form. In a joint venture, list only that portion of the work to be done by your company. If no work is contracted, show NONE.

Earthwork						
Portland Cement Concrete Paving						
HMA Plant Mix						
HMA Paving						
Clean & Seal Cracks/Joints						
Aggregate Bases, Surfaces						
Highway, R.R., Waterway Struc.						
Drainage						
Electrical						
Cover and Seal Coats						
Concrete Construction						
Landscaping						
Fencing						
Guardrail						
Painting						
Signing						
Cold Milling, Planning, Rotomilling						
Demolition						
Pavement Markings (Paint)						
Other Construction (List)						
Totals						

Disclosure of this information is REQUIRED to accomplish the statutory purpose as outlined in the "Illinois Procurement Code." Failure to comply will result in non-issuance of an "Authorization To Bid." This form has been approved by the State Forms Management Center.

Part III. Work Subcontracted to Others.

For each contract described in Part I, list all the work you have subcontracted to others.

	1	2	3	4	Awards Pending
Subcontractor					
Type of Work					
Subcontract Price					
Amount Uncompleted					
Subcontractor					
Type of Work					
Subcontract Price					
Amount Uncompleted					
Subcontractor					
Type of Work					
Subcontract Price					
Amount Uncompleted					
Subcontractor					
Type of Work					
Subcontract Price					
Amount Uncompleted					
Subcontractor					
Type of Work					
Subcontract Price					
Amount Uncompleted					
Total Uncompleted					

Notary

I, being duly sworn, do hereby declare this affidavit is a true and correct statement relating to ALL uncompleted contracts of the undersigned for Federal, State, County, City and private work, including ALL subcontract work, ALL pending low bids not yet awarded or rejected and ALL estimated completion dates.

Officer or Director

Title

Signature

Date

Company

Address

City

State

Zip Code

Subscribed and sworn to before me

this _____ day of _____, _____

(Signature of Notary Public)

My commission expires _____

(Notary Seal)

Add pages for additional contracts



Affidavit of Availability

For the Letting of

Bureau of Construction
2300 South Dirksen Parkway/Room 322
Springfield, IL 62764

Instructions: Complete this form by either typing or using black ink. "Authorization to Bid" will not be issued unless both sides of this form are completed in detail. Use additional forms as needed to list all work.

Part I. Work Under Contract

List below all work you have under contract as either a prime contractor or a subcontractor. It is required to include all pending low bids not yet awarded or rejected. In a joint venture, list only that portion of the work which is the responsibility of your company. The uncompleted dollar value is to be based upon the most recent engineer's or owners estimate, and must include work subcontracted to others. If no work is contracted, show NONE.

	1	2	3	4	Awards Pending	Accumulated Totals
Contract Number						
Contract With						
Estimated Completion Date						
Total Contract Price						
Uncompleted Dollar Value if Firm is the Prime Contractor						
Uncompleted Dollar Value if Firm is the Subcontractor						
Total Value of All Work						

Part II. Awards Pending and Uncompleted Work to be done with your own forces.

List below the uncompleted dollar value of work for each contract and awards pending to be completed with your own forces. All work subcontracted to others will be listed on the reverse of this form. In a joint venture, list only that portion of the work to be done by your company. If no work is contracted, show NONE.

Earthwork						
Portland Cement Concrete Paving						
HMA Plant Mix						
HMA Paving						
Clean & Seal Cracks/Joints						
Aggregate Bases, Surfaces						
Highway, R.R., Waterway Struc.						
Drainage						
Electrical						
Cover and Seal Coats						
Concrete Construction						
Landscaping						
Fencing						
Guardrail						
Painting						
Signing						
Cold Milling, Planning, Rotomilling						
Demolition						
Pavement Markings (Paint)						
Other Construction (List)						
Totals						

Disclosure of this information is REQUIRED to accomplish the statutory purpose as outlined in the "Illinois Procurement Code." Failure to comply will result in non-issuance of an "Authorization To Bid." This form has been approved by the State Forms Management Center.

Part III. Work Subcontracted to Others.

For each contract described in Part I, list all the work you have subcontracted to others.

	1	2	3	4	Awards Pending
Subcontractor					
Type of Work					
Subcontract Price					
Amount Uncompleted					
Subcontractor					
Type of Work					
Subcontract Price					
Amount Uncompleted					
Subcontractor					
Type of Work					
Subcontract Price					
Amount Uncompleted					
Subcontractor					
Type of Work					
Subcontract Price					
Amount Uncompleted					
Subcontractor					
Type of Work					
Subcontract Price					
Amount Uncompleted					
Total Uncompleted					

Notary

I, being duly sworn, do hereby declare this affidavit is a true and correct statement relating to ALL uncompleted contracts of the undersigned for Federal, State, County, City and private work, including ALL subcontract work, ALL pending low bids not yet awarded or rejected and ALL estimated completion dates.

Officer or Director

Title

Signature

Date

Company

Address

City

State

Zip Code

Subscribed and sworn to before me

this _____ day of _____, _____

(Signature of Notary Public)

My commission expires _____

(Notary Seal)

EXHIBIT A - PUBLIC CONTRACT STATEMENT

This Public Contract Statement (the “**Contract Statement**”) has been executed by the below supplier, Contractor or vendor (collectively the “**Contractor**”) in order for the Village of Buffalo Grove to obtain certain information necessary prior to awarding a public contract. The Contract Statement shall be executed and notarized and submitted as part of the Bid Proposal.

CERTIFICATION OF CONTRACTOR/BIDDER

In order to comply with 720 Illinois Compiled Statutes 5/33 E-1 et seq., the Village of Buffalo Grove requires the following certification be acknowledged:

The Contractor certifies that it is not barred from bidding or supplying any goods, services or construction let by the Village of Buffalo Grove with or without bid, due to any violation of either Section 5/33 E-3 or 5/33 E-4 of Article 33E, Public Contracts, of the Chapter 720 of the Illinois Compiled Statutes, as amended. This act relates to interference with public contracting, bid rigging and rotating, kickbacks, and bidding.

CERTIFICATION RELATIVE TO 65 ILCS 5/11-42.1.1

In order to comply with 65 Illinois Compiled Statutes 5/11-42.1.1, the Village of Buffalo Grove requires the following certification:

The Contractor does hereby swear and affirm that it is not delinquent in the payment of any tax administered by the Illinois Department of Revenue unless it is contesting such tax in accordance with the procedures established by the appropriate revenue act, its liability for the tax or the amount of the tax. The undersigned further understands that making a false statement herein: (1) is a Class A misdemeanor, and (2) voids the contract and allows the Village to recover all amounts paid to it under the contract.

CONFLICT OF INTEREST

The Village of Buffalo Grove Municipal Code requires the following verification relative to conflict of interest and compliance with general ethics requirements of the Village:

The Contractor represents and warrants to the Village of Buffalo Grove as a term and condition of acceptance of their Bid Proposal that none of the following Village officials is either an officer or director of Contractor nor owns five percent (5%) or more of the Contractor: the Village President, the members of the Village Board of Trustees, the Village Clerk, the Village Treasurer, the members of the Zoning Board of Appeals and the Plan Commission, the Village Manager and his/her Assistant, or the heads of the various departments within the Village.

If the foregoing representation and warranty is inaccurate, state the name of the Village official who either is an officer or director of your business entity or owns five percent (5%) or more thereof: _____.

IN WITNESS WHEREOF, the below Contractor has signed and sealed this Contract Statement as of this ____ day of _____, 20__.

Print Name of Contractor

Signature

Print Title

Given under my hand and official seal, this ____ day of _____, 20__.

Notary Public

INDEX
FOR
SUPPLEMENTAL SPECIFICATIONS
AND RECURRING SPECIAL PROVISIONS

Adopted January 1, 2022

This index contains a listing of SUPPLEMENTAL SPECIFICATIONS, frequently used RECURRING SPECIAL PROVISIONS, and LOCAL ROADS AND STREETS RECURRING SPECIAL PROVISIONS.

No ERRATA this year.

SUPPLEMENTAL SPECIFICATIONS

Std. Spec. Sec.

Page No.

No Supplemental Specifications this year.



Check Sheet for Recurring Special Provisions

Local Public Agency	County	Section Number
Village of Buffalo Grove	Lake	N/A

Check this box for lettings prior to 01/01/2023.

The Following Recurring Special Provisions Indicated By An "X" Are Applicable To This Contract And Are Included By Reference:

Recurring Special Provisions

<u>Check Sheet #</u>		<u>Page No.</u>
1	<input type="checkbox"/> Additional State Requirements for Federal-Aid Construction Contracts	53
2	<input type="checkbox"/> Subletting of Contracts (Federal-Aid Contracts)	56
3	<input type="checkbox"/> EEO	57
4	<input type="checkbox"/> Specific EEO Responsibilities Non Federal-Aid Contracts	67
5	<input type="checkbox"/> Required Provisions - State Contracts	72
6	<input type="checkbox"/> Asbestos Bearing Pad Removal	78
7	<input type="checkbox"/> Asbestos Waterproofing Membrane and Asbestos HMA Surface Removal	79
8	<input type="checkbox"/> Temporary Stream Crossings and In-Stream Work Pads	80
9	<input type="checkbox"/> Construction Layout Stakes	81
10	<input type="checkbox"/> Use of Geotextile Fabric for Railroad Crossing	84
11	<input type="checkbox"/> Subsealing of Concrete Pavements	86
12	<input type="checkbox"/> Hot-Mix Asphalt Surface Correction	90
13	<input type="checkbox"/> Pavement and Shoulder Resurfacing	92
14	<input type="checkbox"/> Patching with Hot-Mix Asphalt Overlay Removal	93
15	<input type="checkbox"/> Polymer Concrete	95
16	<input type="checkbox"/> Reserved	97
17	<input type="checkbox"/> Bicycle Racks	98
18	<input type="checkbox"/> Temporary Portable Bridge Traffic Signals	100
19	<input type="checkbox"/> Nighttime Inspection of Roadway Lighting	102
20	<input type="checkbox"/> English Substitution of Metric Bolts	103
21	<input type="checkbox"/> Calcium Chloride Accelerator for Portland Cement Concrete	104
22	<input type="checkbox"/> Quality Control of Concrete Mixtures at the Plant	105
23	<input type="checkbox"/> Quality Control/Quality Assurance of Concrete Mixtures	113
24	<input type="checkbox"/> Reserved	129
25	<input type="checkbox"/> Reserved	130
26	<input type="checkbox"/> Temporary Raised Pavement Markers	131
27	<input type="checkbox"/> Restoring Bridge Approach Pavements Using High-Density Foam	132
28	<input type="checkbox"/> Portland Cement Concrete Inlay or Overlay	135
29	<input type="checkbox"/> Portland Cement Concrete Partial Depth Hot-Mix Asphalt Patching	139
30	<input type="checkbox"/> Longitudinal Joint and Crack Patching	142
31	<input type="checkbox"/> Concrete Mix Design - Department Provided	144
32	<input type="checkbox"/> Station Numbers in Pavements or Overlays	145

Local Public Agency

County

Section Number

Village of Buffalo Grove

Lake

N/A

The Following Local Roads And Streets Recurring Special Provisions Indicated By An "X" Are Applicable To This Contract And Are Included By Reference:

Local Roads And Streets Recurring Special Provisions

<u>Check Sheet #</u>		<u>Page No.</u>
LRS 1	Reserved	147
LRS 2	<input type="checkbox"/> Furnished Excavation	148
LRS 3	<input checked="" type="checkbox"/> Work Zone Traffic Control Surveillance	149
LRS 4	<input checked="" type="checkbox"/> Flaggers in Work Zones	150
LRS 5	<input checked="" type="checkbox"/> Contract Claims	151
LRS 6	<input checked="" type="checkbox"/> Bidding Requirements and Conditions for Contract Proposals	152
LRS 7	<input type="checkbox"/> Bidding Requirements and Conditions for Material Proposals	158
LRS 8	Reserved	164
LRS 9	<input type="checkbox"/> Bituminous Surface Treatments	165
LRS 10	Reserved	169
LRS 11	<input checked="" type="checkbox"/> Employment Practices	170
LRS 12	<input checked="" type="checkbox"/> Wages of Employees on Public Works	172
LRS 13	<input checked="" type="checkbox"/> Selection of Labor	174
LRS 14	<input type="checkbox"/> Paving Brick and Concrete Paver Pavements and Sidewalks	175
LRS 15	<input checked="" type="checkbox"/> Partial Payments	178
LRS 16	<input type="checkbox"/> Protests on Local Lettings	179
LRS 17	<input checked="" type="checkbox"/> Substance Abuse Prevention Program	180
LRS 18	<input type="checkbox"/> Multigrade Cold Mix Asphalt	181
LRS 19	<input type="checkbox"/> Reflective Crack Control Treatment	182



Local Public Agency	County	Section Number
Village of Buffalo Grove	Lake	N/A

The following Special Provision supplement the "Standard Specifications for Road and Bridge Construction", adopted

January 1, 2022, the latest edition of the "Manual on Uniform Traffic Control Devices for Streets and Highways", and the "Manual of Test Procedures of Materials" in effect on the date of invitation of bids, and the Supplemental Specification and Recurring Special Provisions indicated on the Check Sheet included here in which apply to and govern the construction of the above named section, and in case of conflict with any parts, or parts of said Specifications, the said Special Provisions shall take precedence and shall govern.

Modifications in the form of General Conditions, Special Provisions, and IDOT District One Special Provisions enclosed.

**TABLE OF CONTENTS
FOR CONTRACT GENERAL CONDITIONS AND SPECIAL PROVISIONS**

General Conditions

1. Scope of Work
2. Description of Work
3. Definition of Village of Buffalo Grove
4. Examination of Site
5. Clean Construction and Demolition Debris (CCDD) Material Disposal
6. JULIE Notification
7. Village Contractor Registration
8. Completion Date
9. Contract Sequencing
10. Construction Work Periods
11. Pre-Construction Meeting
12. Sub-Contracting
13. Authority of the Engineer
14. Use of Fire Hydrants
15. Existing Hardscape
16. Use of the Work Site
17. Indemnification
18. Insurance Requirements
19. Accidents
20. No Assignment
21. Default
22. Delays
23. Compliance With Laws
24. No Waiver of Rights
25. Termination of the Contract
26. Controlling Law and Venue
27. Miscellaneous
28. Application For Payment
29. Certified Payroll Reports
30. Monetary Penalties
31. Maintenance Bond
32. Retainage and Waivers
33. Final Site Inspection
34. Permits and Licenses

Special Provisions

1. Traffic Control and Protection (Special)
2. BITUMINOUS SURFACE TREATMENT (CLASS A-1, A-2, A-3) FOR LOCAL LETTINGS

General Conditions

1. Scope of Work

The provisions of Article 104.02 of the Standard Specifications are hereby amended as follows: **“The Village of Buffalo Grove (Village) expressly reserves the right to remove from or add to the project any portions thereof included in the 2023 Parking Lot Repairs Project. Such reductions or additions, if any, shall be made in writing by the Village prior to execution of the Contract Documents. Any reduction in the scope of work required by the Village prior to the execution of the Contract Documents shall not result in an adjustment to the contract or to the price originally bid.”**

2. Description of Work:

The proposed project consists of Class B and D patching and paint pavement marking of parking lot pavement at the Village's Police Department east parking lot located at 46 Raupp Blvd and Fire Station 25 located at 505 Dundee Rd and any other work necessary to complete the project as described. There is an alternate bid option which includes seal coating the asphalt parking lots prior to pavement marking.

3. Definition of Village of Buffalo Grove

All references in the contract relating to the Department, Awarding Authority, Village of Buffalo Grove, Village, etc. shall mean the Village of Buffalo Grove.

4. Examination of Site:

The Contractor shall be responsible for completing any necessary site inspections prior to submitting a bid on this project. Upon receipt of a bid, it shall be assumed that the Contractor is fully familiar with the project site and the work to be completed.

5. Clean Construction and Demolition Debris (CCDD) Material Disposal

Work under this item shall be performed in compliance with the Illinois Environmental Protection Agency (IEPA) guidelines in effect at the time of construction.

The Contractor will be required to make all arrangements for coordination and submission of the necessary documents with their chosen CCDD or other suitable disposal facility. Written confirmation of preliminary approval must be provided from the disposal facility and confirmed by the Owner as acceptable.

All surplus, clean material generated from the Contractor's activities must be disposed of at an IEPA permitted CCDD or otherwise acceptable facility. The Contractor is responsible for providing documentation to the Village for each load hauled off-site showing the quantity of material and the location the material was disposed of.

Disposal of clean material not in compliance with these requirements will constitute breach of contract. If the Contractor fails to provide adequate documentation supporting the legal disposal of clean material according to this special provision, the Contractor shall be fined \$1,000 per load of material and will assume all liability associated with material disposed of not in compliance with this special provision.

No extra compensation will be allowed to the Contractor for any expenses incurred complying with these requirements including but not limited to: delays, inconvenience, or interruptions in the work resulting from compliance with these requirements. All costs associated with material disposal shall be included into the appropriate unit bid prices for the work.

6. JULIE Notification

The Contractor shall call the Joint Utility Locating Information for Excavators (JULIE) (1-800-892-0123 or 811), a minimum of forty-eight (48) hours in advance of work being done in the area in accordance with Article 107.39 of the Standard Specifications.

For utilities which are not members, excluding homeowners, the Contractor shall contact the owners directly. The Contractor will be required to cooperate with all utility companies and municipal agencies involved in connection with the removal, temporary relocation, reconstruction or abandonment by these agencies of any and all services.

No additional compensation will be allowed the Contractor for any expense incurred by complying with these requirements, or because of delays, inconvenience or interruptions in his work resulting from the failure of the municipal agencies or utility company to remove, relocate, reconstruct or abandon their services.

7. Village Contractor Registration

All bidders are required to fully register with the Village of Buffalo Grove, including IRS Form W-9, at:
<https://vrapp.vendorregistry.com/Vendor/Register/Index/buffalo-grove-village-of-il-vendor-registration>

OR

www.vbg.org/bids

Select the link 'Register My Business'

Please contact Vendor Registry at (844) 802-9202 for assistance in the registration process.

The Village of Buffalo Grove reserves the right to reject any or all proposals if the bidder does not comply with the requirements as stated herein.

8. Completion Date

The Contractor shall commence the work to be performed under this contract, 10 days following the execution of the contract. The work shall be prosecuted in such a manner and with such a supply of materials, equipment and labor as considered necessary to ensure its completion according to the time specified in the contract. The Contractor shall substantially complete all work in the contract by **Friday, July 28, 2023**, including landscape restoration, as defined in Article 108.04 of the Standard Specifications. If the alternate is selected and awarded, all work in the contract shall be substantially completed by **Friday, July 28, 2023**.

Following substantial completion, the Contractor shall provide the Engineer written notice in accordance with Article 105.13 of the Standard Specifications. The Contractor will have fourteen (14) calendar days to correct any deficiencies following the scheduled final inspection and punch list submittal by the Engineer.

In case of failure to complete the work on time by the interim completion date, final completion date, working days, and/or the deficient punch list items, the provisions of Article 108.09 of the Standard Specifications shall apply, **except regardless of the contract amount, the daily charge shall be \$2,000 per calendar day overrun**. Landscape restoration planting times shall follow Article 250.07 of the Standard Specifications.

The estimated Village Board award date for this project is Monday, March 20, 2023.

9. Contract Sequencing

The Contractor shall notify the Engineer at least 72 hours in advance of beginning work and 48 hours prior to construction commencement. Construction operations shall be conducted in a manner such that streets will remain open to all traffic. At no time shall residents or business owners be kept out of their driveway over a weekend or holiday as defined in Article 107.09 of the Standard Specifications.

10. Construction Work Periods

Construction operations shall be completed in accordance with Article 107.09 of the Standard Specifications. All work shall be confined to the period beginning at 7:00 AM and ending at 6:00 PM on weekdays and 8:00 AM to 6:00 PM on Saturdays. No work shall be done on Sundays or legal holiday periods as defined in article 107.09 of the Standard Specifications.

Any work outside the allowed time periods in accordance with the Village Ordinance, including but not limited to, material deliveries, mobilization of equipment, warming up machinery, or truck staging, a penalty of \$1,000 per occurrence may be imposed.

11. Pre-Construction Meeting

Prior to commencing any construction operations, there shall be a pre-construction meeting. The Village or Engineer will set the time and date of the meeting following Contract award.

The following shall be submitted by the Contractor for review at the pre-construction meeting:

A Progress Schedule in accordance with Article 108.02.

The 24-hour emergency phone number and contact information of the assigned Contractor's superintendent, or otherwise.

The name and 24-hour emergency phone number of the person in the direct employ of the Contractor who is responsible for administering the Traffic Control and Protection on the Contract

A list of subcontractors with contact information, including but not limited to name, phone number, and email address, and include quantity and type of work to be sublet for each respective subcontractor in accordance with Article 108.01 of the Standard Specifications.

Any respective quality control plans.*

Any applicable shop drawing submittals.*

*Shop drawings and quality control plans for the project shall be submitted to the Village no less than ten (10) calendar days from the effective notice to proceed dated letter or the scheduled date of the pre-construction meeting, whichever occurs earlier. A monetary penalty of \$500 may be imposed for each required submittal thereafter.

12. Sub-Contracting

Add the following to the end of ARTICLE 108.01 SUBCONTRACTING.

"The apparent low Bidder on a "Request for Approval of a Subcontractor" (BC 260a) form shall submit to the office of Engineer within ten (10) calendar days after the receipt of bids, a list of the names of Bidder's proposed subcontractors along with a description of the work to be performed by each. The Village will then review and reserves the right to reject the use of any subcontractor on the project due to past performance or the apparent inability to properly perform the item of work."

13. Authority of the Engineer

Revise ARTICLE 105.01 AUTHORITY OF ENGINEER to read:

"All work shall be done in accordance with the requirements of the Contract, the Engineer shall have the right, but not the obligation, to observe all work. The Engineer shall decide all questions that arise as to the interpretation of the Plans and Specifications and as to disputes and mutual rights between Contractors under the Specifications. The Engineer shall advise the Village of Buffalo Grove as to the quality and acceptability of materials furnished and work performed, rate of progress of the work, and acceptable fulfillment of the Contract. The Engineer will determine the amount of materials furnished and work performed. The Engineer's advice and determinations shall be conditions precedent to the right of the Contractor to receive money due the Contractor under the Contract."

"The Engineer will notify the Contractor in writing if the work is to be suspended by the Village of Buffalo Grove wholly or in part due to the failure of the Contractor to carry out provisions of the contract; for failure to carry out orders; for such periods due to unsuitable weather; for conditions considered unsuitable for the prosecution of the work or for any other condition or reason deemed to be in the public interest."

"In case of failure on the part of the Contractor to execute work as directed by the Engineer, the Village of Buffalo Grove may, at the expiration of a period of 48 hours after giving notice in writing to the Contractor, proceed to execute such work as may be deemed necessary, and the cost thereof shall be deducted from compensation due or which may become due to the Contractor under the contract."

The Engineer shall not assume any of the responsibilities of the Contractor's superintendent or of subcontractors; shall not expedite the work for the Contractor; and shall not advise on, or issue directions concerning aspects of construction means, methods, techniques, sequences or procedures, or safety precautions in connection with the work.

14. Use of Fire Hydrants

The indiscriminate use of fire hydrants is strictly prohibited. The Contractor can obtain non-potable water in bulk at no charge at the Buffalo Grove Public Works Department, 51 Raupp Blvd. The Contractor shall provide a water truck or containment and driver to obtain and

transport the water. All water obtained from the Village shall be used for this project only. If deemed necessary, the Village reserves the right to restrict or refuse the use of Village water. The Contractor will be responsible for executing the required paperwork and follow all requirements of the Village. If it is determined that the Contractor or its subcontractors operate or use a Village fire hydrant, a monetary penalty of \$1,000 per occurrence that will be imposed.

15. Existing Hardscape

Any damage to existing hardscape from tracked equipment or due to the Contractor's negligence, workmanship, or neglect shall be replaced at the Contractor's expense. It is recommended rubber tired or rubber tracked equipment is used. Any unwarranted disturbance to the existing hardscape to remain will warrant repairs made joint to joint and in conformance with the bid documents with limits specified in the Maintenance Letter of Credit general condition. The Engineer and Village shall determine the limit of removal and replacement operations, and all work shall be completed to the satisfaction of the Engineer.

16. Use of the Work Site

The Contractor shall use the Work Site solely to complete the Work and such related activities as may be authorized or directed by the Village. Except as provided herein, Contractor shall not (nor shall Contractor cause or permit any employee or person under Contractor's control) to display or broadcast commercial, political, or religious messages or advertisements of any nature at the Work Site or in connection with the Work. The foregoing shall not be construed to prohibit the following at the Work Site or in connection with the Work: (a) the use of equipment, materials, or other items (*e.g.* personnel uniforms and clothing) that identify the Contractor (such as by displaying the Contractor's name, logo, slogan, contact information, or similar messages) or that identify the maker or supplier of such equipment, material, or item; or (b) the use or display of signs, flags, cones, traffic control devices, markers, or other similar devices that reasonably relate to the Work, Work Site safety, public safety, or regulatory compliance; or (c) personal speech, religious practice, or expression by any individual performing Work or at the Work Site; or (d) upon written approval or direction of the Village, the display of information regarding the sponsor of the Work or funding sources for the Work.

In addition, Contractor shall not (nor shall Contractor require or permit its personnel, subcontractors, or subcontractors' personnel to) conduct any prohibited political activity at the Work Site or while performing the Work. Contractor and its personnel or subcontractors (including any subcontractor's personnel) shall not intentionally or knowingly use the Work Site or any other property or resources of the Village in connection with any prohibited political activity. For purposes of this section, the term "prohibited political activity" shall have the meaning set forth in Section 5 of the State Officials and Employees Ethics Act, 5 ILCS 430/1-5.

17. Indemnification

To the fullest extent permitted by law, the Contractor agrees to defend, pay on behalf of, indemnify, and hold harmless the Village, its elected and appointed officials, agents, employees and volunteers and others working on behalf of the Village against any and all claims, demands, suits or loss, including all costs connected therewith, and for any damages which may be asserted, claimed or recovered against or from the Village, its elected and appointed officials, agents, employees and volunteers and others working on behalf of the Village, by reason of personal injury, including bodily injury and death, and/or property damage, whether damage to property of the Village or of a third party, including loss of use thereof, which arises out of or is in any way connected or associated with the Contract and the Work.

18. Insurance Requirements

12.04.080 - Insurance.

A. Required Coverages and Limits. Unless otherwise provided by franchise, license, or similar agreement, each Contractor occupying right-of-way or constructing any facility in the right-of-way shall secure and maintain the following liability insurance policies insuring the Contractor as named insured and naming the Village, and its elected and appointed officers, officials, agents, and employees as additional insureds on the policies listed in subsection (A)(1) and (A)(2) of this section:

1. Commercial general liability insurance, including premises-operations, explosion, collapse, and underground hazard (commonly referred to as "X," "C," and "U" coverages) and products-completed operations coverage with limits not less than:
 - a. Five million dollars for bodily injury or death to each person,
 - b. Five million dollars for property damage resulting from any one accident, and
 - c. Five million dollars for all other types of liability;

2. Automobile liability for owned, non-owned and hired vehicles with a combined single limit of one million dollars for personal injury and property damage for each accident;
3. Worker's compensation with statutory limits; and
4. Employer's liability insurance with limits of not less than one million dollars per employee and per accident.

If the Contractor is not providing such insurance to protect the contractors and subcontractors performing the work, then such contractors and subcontractors shall comply with this section.

- B. Excess or Umbrella Policies. The coverages required by this section may be in any combination of primary, excess, and umbrella policies. Any excess or umbrella policy must provide excess coverage over underlying insurance on a following-form basis such that when any loss covered by the primary policy exceeds the limits under the primary policy, the excess or umbrella policy becomes effective to cover such loss.
- C. **Copies Required. The Contractor shall provide copies of any of the policies including all endorsements or certificates required by this section to the Village within ten calendar days following receipt of a written request therefor from the Village.**
- D. Maintenance and Renewal of Required Coverages. The insurance policies required by this section shall contain the following endorsement:

"It is hereby understood and agreed that this policy may not be canceled nor the intention not to renew be stated until thirty (30) calendar days after receipt by the Village, by registered mail or certified mail, return receipt requested, of a written notice addressed to the Village Manager of such intent to cancel or not to renew."

Within ten (10) calendar days after receipt by the Village of said notice, and in no event later than ten (10) calendar days prior to said cancellation, the Contractor shall obtain and furnish to the Village evidence of replacement insurance policies meeting the requirements of this section.

- E. Self-Insurance. A Contractor may self-insure all or a portion of the insurance coverage and limit requirements required by subsection A of this section. A Contractor that self-insures is not required, to the extent of such self-insurance, to comply with the requirement for the naming of additional insureds under subsection A of this section, or the requirements of subsections B through D of this section. A Contractor that elects to self-insure shall provide to the Village evidence sufficient to demonstrate its financial ability to self-insure the insurance coverage and limit requirements required under subsection A of this section, such as evidence that the Contractor is a "private self-insurer" under the Workers Compensation Act.
- F. Effect of Insurance and Self-Insurance on Contractor's Liability. The legal liability of the Contractor to the Village and any person for any of the matters that are the subject of the insurance policies or self-insurance required by this section shall not be limited by such insurance policies or self-insurance or by the recovery of any amounts thereunder.
- G. Insurance Companies. All insurance provided pursuant to this section shall be effected under valid and enforceable policies, issued by insurers legally able to conduct business with the licensee in the State of Illinois. All insurance carriers and surplus line carriers shall be rated "A-" or better and of a class size "X" or higher by A.M. Best Company.
- H. Verification of Coverage. **Contractor shall furnish the Village with certificates of insurance naming the Village, its officials, agents, employees, and volunteers as additional insured's and with original endorsements, affecting coverage required herein.** The certificates and endorsements for each insurance policy are to be signed by a person authorized by that insurer to bind coverage on its behalf. The certificates and endorsements are to be received and approved by the Village before any work commences. The Village reserves the right to request full certified copies of the insurance policies and endorsements.
- I. Subcontractors. Contractor shall include all subcontractors as insured's under its policies or shall furnish separate certificates and endorsements for each subcontractor. All coverage's for subcontractors shall be subject to all of the requirements stated herein.
- J. Assumption of Liability. The contractor assumes liability for all injury to or death of any person or persons including employees of the contractor, any subcontractor, any supplier or any other person and assumes liability for all damage to property sustained by any person or persons occasioned by or in any way arising out of any work performed pursuant to the Contract.
- K. Workers' Compensation and Employers' Liability Coverage. The insurer shall agree to waive all rights of subrogation against the Village of Buffalo Grove, its officials, employees, agents and volunteers for losses arising from work performed by Contractor for the municipality.

- L. Failure to Comply. In the event the Contractor fails to obtain or maintain any insurance coverage's required under this contract, The Village may purchase such insurance coverage's and charge the expense thereof to the Contractor.

Nothing contained herein is intended to constitute, nor shall it constitute a waiver of the rights, defenses and/or other immunities provided or available to the Village under law including, but not limited to, the Local Governmental and Governmental Employees Tort Immunity Act.

19. Accidents

In the event of any accident of any kind that involves the general public or property of the Village or a third party, the Contractor shall immediately notify the Village by phone as well as provide Notice of the same. The Notice shall include a full accounting of all details of the accident. The Contractor shall furnish the Village with copies of all reports of such accidents at the same time that the reports are forwarded to any other interested parties.

20. No Assignment

If the Contractor sublets or assigns any part of the Work then the Contractor shall not under any circumstances be relieved of its liabilities hereunder. All transactions of the Village shall be with the Contractor. Subcontractors shall be recognized only in the capacity of employees or workmen and shall be subject to the same requirements as to character and competence. The Contractor shall not assign, transfer, convey, sell or otherwise dispose of the whole or any part of this Contract to any person, firm or corporation without written consent of the Village or authorized representative.

21. Default

The following shall constitute a default an "Event of Default" by the Contractor under this Contract:

- A. If the Contractor shall fail to strictly observe or perform one or more of the terms, conditions, covenants and agreements of this Contract;
- B. If there shall be placed on any property owned by the Village any mechanics', materialmens' or suppliers' lien;
- C. If there shall be instituted any proceeding against the Contractor seeking liquidation, dissolution or similar relief and the same shall not be dismissed within forty-five (45) calendar days;
- D. If there shall be appointed any trustee, receiver or liquidator of the Contractor and such appointment shall not have been vacated within forty-five (45) calendar days; and
- E. If the Contractor fails to maintain or obtain any and all permits, licenses and the like, if any, required by the Village, State or Federal governments for the Work.

Upon any Event of Default the Village shall have the option of (i) terminating the Contract; (ii) pursuing any remedy available to it at law or in equity; or (iii) pursuing both simultaneously. In addition, upon an Event of Default, the Village may withhold payments due to the Contractor until it has hired a replacement of the Contractor and deducted all costs of hiring a replacement.

22. Delays

The Contractor shall not be liable in damages for delays in performance when such delay is the result of fire, flood, strike, acts of God, or by any other circumstances which are beyond the control of the Contractor; provided, however, under such circumstances the Village may, at its option, cancel the Contract.

23. Compliance With Laws

The Contractor shall comply with all applicable laws, regulations and rules promulgated by any federal, state, local, or other governmental authority or regulatory body pertaining to all aspects of the Work, now in effect, or which may become in effect during the performance of the Work. The scope of the laws, regulations, and rules referred to in this paragraph includes, but is in no way limited to, the Illinois Human Rights Act, Illinois Equal Pay Act of 2003, Occupational Safety & Health Act along with the standards and regulations promulgated pursuant thereto (including but not limited to those safety requirements involving work on elevated platforms), all forms of traffic regulations, public utility, Interstate and Intrastate Commerce Commission regulations, Workers' Compensation Laws, Public Construction

Bond Act, Public Works Preference Act, Employment of Illinois Workers on Public Works Act, USA Security Act, federal Social Security Act (and any of its titles), and any other law, rule or regulation of the Illinois Department of Labor, Department of Transportation, Illinois Environmental Protection Act, Illinois Department of Natural Resources, Illinois Department of Human Rights, Human Rights Commission, EEOC, and the Village of Buffalo Grove. Notwithstanding the following, the Contractor shall particularly note that:

A. NO DISCRIMINATION – The Contractor shall comply with the provisions of the Illinois Public Works Employment Discrimination Act and the Illinois Human Rights Act/Equal Opportunity Clause which, pursuant to Illinois law, are deemed to be part of this Contract.

B. FREEDOM OF INFORMATION - The Contractor agrees to furnish all documentation related to the Contract, the Work and any documentation related to the Village required under an Illinois Freedom of Information Act (ILCS 140/1 et. seq.) ("FOIA") request within five (5) calendar days after the Village issues Notice of such request to the Contractor. The Contractor agrees to defend, indemnify and hold harmless the Village, and agrees to pay all reasonable costs connected therewith (including, but not limited to attorney's and witness fees, filing fees and any other expenses) for the Village to defend any and all causes, actions, causes of action, disputes, prosecutions, or conflicts arising from Contractor's actual or alleged violation of FOIA or the Contractor's failure to furnish all documentation related to a FOIA request within five (5) calendar days after Notice from the Village for the same. Furthermore, should the Contractor request that the Village utilize a lawful exemption under FOIA in relation to any FOIA request thereby denying that request, Contractor agrees to pay all costs connected therewith (such as attorneys' and witness fees, filing fees and any other expenses) to defend the denial of the request. This defense shall include, but not be limited to, any challenged or appealed denials of FOIA requests to either the Illinois Attorney General or a court of competent jurisdiction.

C. ILLINOIS WORKERS ON PUBLIC WORKS ACT - To the extent applicable, the Contractor shall comply with the Illinois Workers on Public Works Act, 30 ILCS 570/1 et seq., and shall provide to the Village any supporting documentation necessary to show such compliance.

D. NOT A BLOCKED PERSON - The Contractor affirms and covenants that neither the Contractor nor any individual employed by the Contractor for this Work or under this Contract is a person forbidden from doing business with a unit of local government under Executive Order No. 13224 (Sept 23, 2001), 66 Fed.Reg. 49,079 (Sept 23, 2001) or is a person registered on the Specially Designated Nationals and Blocked Persons List. The Contractor shall indemnify the Village from all costs associated with failure to comply with this paragraph.

E. SUBSTANCE ABUSE PREVENTION ON PUBLIC WORKS ACT - The Contractor knows, understands and acknowledges its obligations under the Substance Abuse Prevention on Public Works Act (820 ILCS 265/1 et seq.), and shall comply and require all subcontractors and lower tiered contractors to comply with the requirements and provisions thereof.

24. No Waiver of Rights

A waiver by the Village of any Event of Default or any term of provision of this Contract shall not be a waiver of the same Event of Default, another Event of Default or any other term or provision of this Contract.

25. Termination of the Contract

Voluntary Termination. Notwithstanding any other provision hereof, the Village may terminate this Contract during the Initial Term with or without cause, at any time upon thirty (30) calendar days prior written notice to the Contractor.

Termination for Breach. Either party may terminate this Contract upon written notice to the other party following material breach of a material provision of this Contract by the other party if the breaching party does not cure such breach within fifteen (15) calendar days of receipt of written notice of such breach from the non-breaching party.

26. Controlling Law and Venue

This Contract is entered into in the State of Illinois, for work to be performed in the State of Illinois and shall be governed by and construed in accordance with the laws of the State of Illinois. Any legal matters or dispute shall be resolved in the Circuit Court of Cook County and the Parties hereby submit to the jurisdiction of such Circuit Court. This Contract shall be construed without regard to any presumption or other rule requiring construction against the Party causing the Contract to be drafted.

27. Miscellaneous

- A. **AMENDMENT** – This Contract may be amended only in writing executed by both Parties.
- B. **NO RECORDING** – This Contract, or a memorandum thereof, may not be recorded in any form by either Party. If either Party records this Contract, or a memorandum thereof, they shall immediately file a release of the same.
- C. **SECTION HEADINGS** – The headings in the Contract are intended for convenience only and shall not be taken into consideration in any construction or interpretation of the Contract.
- D. **NO THIRD PARTY BENEFICIARIES** – This Contract does not confer any rights or benefits on any third party.
- E. **BINDING EFFECT** – This Contract shall be binding and inure to the benefit of the Parties hereto, their respective legal representatives, heirs and successors-in-interest.
- F. **ENTIRE AGREEMENT** – This Contract supersedes all prior agreements and understandings and constitutes the entire understanding between the Parties relating to the subject matter hereof.
- G. **SEVERABILITY** - If any term, condition or provision of the Contract is adjudicated invalid or unenforceable, the remainder of the Contract shall not be affected and shall remain in full force and effect, to the fullest extent permitted by law.
- H. **TORT IMMUNITY DEFENSES** - Nothing contained in this Contract is intended to constitute nor shall constitute a waiver of the rights, defenses, and immunities provided or available to the Village under the Local Governmental and Governmental Employees Tort Immunity Act, 745 ILCS 10 *et seq.*

28. Application For Payment

At least once each month, the Engineer will make a written estimate of the quantity of work performed in accordance with the Contract, and the value thereof at the contract unit prices according to Article 109.02 of the Standard Specifications. For each pay period, the quantity cut off will be the first Saturday of each month. During the second week, the Engineer and Contractor will agree to the quantities completed to-date. The Contractor shall submit an agreed upon invoice electronically to the Engineer by the end of the working day of the third Monday of the month. The Village will begin their payment process and will result in the review of the payment at the next regularly scheduled Village Board meeting. Prior to the release of payment, the Contractor shall submit electronically, all certified payroll reports, applicable waivers, and a notarized and signed clarifying statement for Village Attorney review and subsequent approval. Prior to the release of the check, hard-copies of all applicable waivers and the clarifying statement shall be received by the Village.

All payments under this Contract must be approved by the Village Board at a regularly scheduled meeting. The Village reserves the right to request any receipts, invoices, proof of payments as the Village, in its sole discretion, may deem necessary to justify the payment requested prior to paying the requested payment. A Final Lien Waiver from the Contractor, its subcontractors, and all material suppliers shall be furnished with the final application for payment.

The Contractor acknowledges that the Village is a unit of local government and that all payments under the Contract are subject to the Local Government Prompt Payment Act, 50 ILCS 505 *et seq.* To that extent, the Village shall have forty-five calendar (45) days from receipt of a bill or invoice to pay the same before it is considered late under the Contract. Interest, if any, charged for any late payments will be subject to the interest rate caps specified in the Prompt Payment Act.

29. Certified Payroll Reports

Pursuant to PA 100-1177 the Illinois Department of Labor (IDOL) has activated an electronic database (Payroll Portal) capable of accepting and retaining certified payrolls submitted under the State of Illinois Prevailing Wage Act (820 ILCS/130/1). All contractors and subcontractors completing work for the Village of Buffalo Grove pursuant to the Act must submit all certified payroll through the IDOL Payroll Portal.

The Village is an Illinois unit of local government and the Work hereunder is subject to the Illinois Prevailing Wage Act, 820 ILCS 130/0.01, *et seq.* Consequently, the Contractor and each subcontractor shall submit with their application for payment(s) the email certification received from their IDOL Payroll Portal submittal with each of their pay requests. Any delay in processing the payments due to a lack of aforementioned email certification shall not be an event of default by the Village and shall not excuse any delay by the Contractor who

shall proceed with the Work as if no delay in payment has occurred. The Contractor and Village shall agree to take any further steps not outlined above to ensure compliance with the Prevailing Wage Act. Upon two business days' Notice, the Contractor and each subcontractor shall make available to the Village their records to confirm compliance with the Prevailing Wage Act. Finally, to ensure compliance with Prevailing Wage Act, the Contractor and each subcontractor shall keep for a period of not less than 5 years after the Work has been completed records of all laborers, mechanics, and other workers employed by them for the Work; the records shall include each worker's name, address, telephone number, classification or classifications, the hourly wages paid in each period, the number of hours worked each day, the starting and ending times of work each day and, when available, last four digits of the social security number. The Contractor shall provide a list of every name, address, phone number and email of every sub-contractor for the Work.

If the contractor must submit the payroll to the Village of Buffalo Grove for reasons outside of their control, the Village requests that the Contractor submit all certified payroll reports, including subcontractors, and EEO reporting be sent electronically in separate files for each respective Contractor/subcontractor with the weeks ending date in the file name to tsianis@vbg.org (i.e. Contractor Name Week Ending.pdf) as shown in the sample letter in Exhibit D.

The Contractor is responsible for providing all records in accordance with the Illinois Department of Labor's (IDOL) requirements pertaining to the Prevailing Wage Act on the standard IDOL form. Only the last four (4) digits of the employee's social security number will be required; the remaining digits shall be "X" or redacted. To complete the certified payroll request for release of payment, the Contractor must supply a signed and notarized written statement that all necessary documentation has been turned over for the pay period pertaining to that payment requested.

Under P.A. 98-0328, the public body must retain copies of the certified payroll for 5 years rather than 3 years as was the case previously. The Illinois Department of Labor (IDOL) has created model certified payroll forms which can be found at the IDOL website www.illinois.gov/idol. The new form consists of three pages identified as the "certified transcript of payroll affidavit" and "certified transcript of payroll instructions". The new forms on the IDOL website can be filled in online and then printed out. Under P.A. 98-0482, contractors and subcontractors will have to provide additional information with respect to working hours, wage rates, overtime rates and fringe benefits. The IDOL's model certified payroll forms are the most current forms for compliance with P.A. 98-0482 and should be used in public works contracts.

30. Monetary Penalties

All work shall be completed in accordance with the Contract Documents in a reasonable and timely manner. For each occurrence that work is not completed in a reasonable and timely manner, a monetary penalty will be deducted from the final pay application. The Contractor shall make themselves and all subcontractors aware of the following deficiency and deductions:

Description	Penalty	Per Occurrence
Failure to Sweep Roadway	\$250	Calendar Day
Failure to Provide Access in a Timely Manner	\$250	Household/Occurrence Per Day
Failure to Provide Weekly Update to Engineer/Maintain Schedule	\$1,000	Per Occurrence
Failure to Attend a Scheduled Weekly Meeting	\$1,000	Per Occurrence
Use of Fire Hydrant or Valve	\$1,000	Each
Failure to Provide Maintenance of Roadway in a Timely Manner as Determined by the Engineer	\$1,000	Calendar Day
Entering Private Property	\$500	Per Occurrence
Failure to Provide Portable Facilities	\$100	Calendar Day
Illicit Discharge of Silt or Construction Debris	\$1,000	Per Occurrence
Failure to Submit Shop Drawings on Time	\$500	Per Occurrence
Failure to Maintain Erosion and/or Sediment Control Devices	\$1,000	Per Occurrence
Working Outside Allowable Work Hours	\$1,000	Per Occurrence

At the discretion of the Engineer and without notice, the Contractor shall have deducted the monetary penalty amount as listed above for each occurrence on the final pay application.

31. Maintenance Bond

The Contractor will be required to post a Maintenance Bond for a period of One Year (1-yr) from the date of final acceptance by the Village. Final acceptance will be the date the Final Payment is made to the Contractor. The bond shall be in a form acceptable to the Village in the amount of 10% (ten percent) of the awarded contract value. Unless under emergency situations, the Village will offer the Contractor the ability to fix or repair any item prior to the bond being called. If the Contractor elects to perform the repairs themselves, all work must be complete within 14 calendar days of notice from the Village or the Village reserves the right to perform the repairs themselves.

The Maintenance Bond shall cover all necessary repairs or replacements as deemed necessary by the Village due to poor workmanship, failed materials, settlement of trenches, excessively spalled, chert popped or cracked concrete, storm and water main failures, restoration establishment, and other items of work completed by the Contractor.

All required pavement repairs shall be from the curb line to the nearest cold joint. Pavement repairs shall have all joints routed and filled with crack seal material including along the edge of pavement, one month after installation.

If the Contractor elects to not perform the repairs or does not perform them in the time allotted, the Village will perform the work and collect from the bond any damages incurred by the Village to perform the repairs.

32. Retainage and Waivers

The Village of Buffalo Grove has the option to retain from the amount due to the Contractor a maximum of ten percent (10%) from each pay request. The Contractor may request the retainage be reduced and provide reasoning for such reduction in writing to the Village. The Village has the option to accept or deny the request and shall be considered final. The retainage may be held until the Village determines the project to be final and accepted, at which time any warranty or maintenance period shall commence.

The Contractor shall submit, for each pay request submittal, original partial or final waivers from all subcontractors and material suppliers for the work payment is requested from the Village; trailing waivers will not be permitted. The Village will not remit payment to the Contractor until all original hard-copies of waivers for the work the Contractor is requesting payment for are received and reviewed. To help expedite the process, the Village is willing to review draft waivers after the invoice has been submitted for the pay request. When the draft waivers are reviewed and found acceptable, and the check is cut according to the Village's Warrant schedule, then the check and final waivers can be exchanged accordingly.

33. Final Site Inspection

After the Contractor has submitted the notice of final completion to the Village, the Contractor shall schedule a final site inspection with the Village and Engineer. The Contractor shall provide a laborer or Contractor's representative for the final inspection that will be responsible for the following:

1. Review general site cleanliness and condition of landscaping, curb, sidewalk, pavement, etc.

Upon completion of the final site inspection, the Engineer will provide the Contractor a list of any deficiencies documented. The Contractor will have fourteen (14) calendar days to correct any deficiencies following the scheduled final inspection and punch list submittal by the Engineer.

34. Permits and Licenses

The Contractor shall procure all permits and licenses, pay all charges and fees, and give all notices necessary and incident to the due and lawful prosecution of the work in accordance with Article 107.04 of the Standard Specifications. No work shall be performed until all applicable permit requirements are fulfilled.

Special Provisions

1. Traffic Control and Protection (Special)

Traffic Control shall be according to the applicable sections of the Standard Specifications, the Supplemental Specifications, the "Illinois Manual on Uniform Traffic Control Devices for Streets and Highways", any special details and Highway Standards contained in the plans, and the Special Provisions contained herein.

Special attention is called to Article 107.09 of the Standard Specifications and the following Highway Standards, Details, Quality Standard for Work Zone Traffic Control Devices, Recurring Special Provisions and Special Provisions contained herein, relating to traffic control.

Delays to the Contractor caused by complying with these requirements will be considered included in the cost of the contract, and no additional compensation will be allowed.

Standards

701101, 701106, 701606, 701801 and 701901

Details

Special Provisions

Maintenance of Roadways and Erosion Control
LRS 3 – Work Zone Traffic Control Surveillance
BDE – Work Zone Traffic Control Devices

No signage shall be installed within the Illinois Department of Transportation right-of-way without prior approval by IDOT and all applicable permit requirements are fulfilled. The Contractor shall procure all permits and licenses, pay all charges and fees, and give all notices necessary and incident to the due and lawful prosecution of the work in accordance with Article 107.04 of the Standard Specifications.

No roads or segments shall be closed without prior written approval from the Village and Engineer. The Contractor must present to the Engineer, a detour plan with a detailed description addressing how resident access will be maintained and all applicable signage. Submittal of a road closure request to the Engineer does not guarantee approval. Any additional traffic control devices required for road closures per the Contractor's request shall not be paid for separately but shall be included in the cost of the contract.

The Contractor shall be properly advised of the regulated weight limits within the surrounding areas of the project. No additional compensation in time or monetary value will be allowed. The Village of Buffalo Grove Police Department requires permits for Overweight/Over-Sized Trucks or Vehicles. The Contractor can obtain additional information by calling (847) 459-2560.

This work will be measured in place and paid for at the contract unit price per lump sum (LS) for TRAFFIC CONTROL AND PROTECTION, (SPECIAL), which shall include all labor, material, and equipment required to complete the work as specified herein.

2. BITUMINOUS SURFACE TREATMENT (CLASS A-1, A-2, A-3) FOR LOCAL LETTINGS

All references to Sections and Articles in this Special Provision shall be construed to mean specific Sections and Articles in the Standard Specifications for Road and Bridge Construction adopted by the Department of Transportation.

Revise Articles 403.15 and 403.16 to read:

403.15 Method of Measurement. Measurement of the volume of asphalt binders, emulsified asphalts, rapid curing liquid asphalt, medium curing liquid asphalts, slow curing liquid asphalts, asphalt fillers, and road oils will be based on the volume of the material at 60 °F (15.6 °C). Volumes measured at higher or lower temperatures will be corrected to the volume at 60 °F (15.6 °C) using the Standard ASTM-IP Petroleum Measurement Tables, ASTM D 1250.

Payment will not be made for bituminous materials in excess of 105 percent of the amount specified by the Engineer.

When bituminous materials are delivered by tank truck from a refinery or from a storage tank, a weight ticket for each truck load shall be furnished to the inspector. The ticket shall show the weight of the empty truck (the truck being weighed each time before it is loaded), the

weight of the loaded truck, and the net weight of the bituminous material. If the material is being measured for payment by the gallon (liter), the specific gravity at 60 °F/60 °F (15.6 °C/15.6 °C) of the bituminous material in the tank truck and the number of gallons (liters) at 60 °F (15.6 °C) shall be shown on the weight ticket.

Cover Coat Aggregate and Seal Coat Aggregate will be measured in tons (metric tons) according to the requirements of Article 311.08(b), except that measurement for payment will not be made for aggregate in excess of 110 percent of the amount specified by the Engineer.

403.16 Basis of Payment. This work will be paid for at the contract unit price per gallon (liter) for BITUMINOUS MATERIALS (PRIME COAT), BITUMINOUS MATERIALS (COVER AND SEAL COATS), and POLYMERIZED BITUMINOUS MATERIALS (COVER AND SEAL COATS); or at the contract unit price per ton (metric ton) for BITUMINOUS MATERIALS (PRIME COAT), BITUMINOUS MATERIALS (COVER AND SEAL COATS), and POLYMERIZED BITUMINOUS MATERIALS (COVER AND SEAL COATS); and per ton (metric ton) for COVER COAT AGGREGATE and SEAL COAT AGGREGATE.

When provided as a payment item, the preparation of the base or existing surface will be measured and paid for as specified in Section 358. If not provided as a payment item, preparation of base or existing surface shall be considered as included in the contract unit price(s) for the bituminous surface treatment.

BDE SPECIAL PROVISIONS
For the January 20, 2023 and March 10, 2023 Lettings

The following special provisions indicated by a “check mark” are applicable to this contract and will be included by the Project Coordination and Implementation Section of the Bureau of Design & Environment (BDE).

File Name	#		Special Provision Title	Effective	Revised	
	80099	1	<input type="checkbox"/>	Accessible Pedestrian Signals (APS)	April 1, 2003	Jan. 1, 2022
	80274	2	<input type="checkbox"/>	Aggregate Subgrade Improvement	April 1, 2012	April 1, 2022
	80192	3	<input type="checkbox"/>	Automated Flagger Assistance Device	Jan. 1, 2008	
	80173	4	<input type="checkbox"/>	Bituminous Materials Cost Adjustments	Nov. 2, 2006	Aug. 1, 2017
	80426	5	<input type="checkbox"/>	Bituminous Surface Treatment with Fog Seal	Jan. 1, 2020	Jan. 1, 2022
	80436	6	<input type="checkbox"/>	Blended Finely Divided Minerals	April 1, 2021	
*	80241	7	<input type="checkbox"/>	Bridge Demolition Debris	July 1, 2009	
*	50531	8	<input type="checkbox"/>	Building Removal	Sept. 1, 1990	Aug. 1, 2022
*	50261	9	<input type="checkbox"/>	Building Removal with Asbestos Abatement	Sept. 1, 1990	Aug. 1, 2022
	80384	10	<input type="checkbox"/>	Compensable Delay Costs	June 2, 2017	April 1, 2019
*	80198	11	<input type="checkbox"/>	Completion Date (via calendar days)	April 1, 2008	
*	80199	12	<input type="checkbox"/>	Completion Date (via calendar days) Plus Working Days	April 1, 2008	
	80261	13	<input type="checkbox"/>	Construction Air Quality – Diesel Retrofit	June 1, 2010	Nov. 1, 2014
	80434	14	<input type="checkbox"/>	Corrugated Plastic Pipe (Culvert and Storm Sewer)	Jan. 1, 2021	
*	80029	15	<input type="checkbox"/>	Disadvantaged Business Enterprise Participation	Sept. 1, 2000	Mar. 2, 2019
	80229	16	<input type="checkbox"/>	Fuel Cost Adjustment	April 1, 2009	Aug. 1, 2017
	80447	17	<input checked="" type="checkbox"/>	Grading and Shaping Ditches	Jan. 1, 2023	
	80433	18	<input type="checkbox"/>	Green Preformed Thermoplastic Pavement Markings	Jan. 1, 2021	Jan. 1, 2022
	80443	19	<input type="checkbox"/>	High Tension Cable Median Barrier Removal	April 1, 2022	
	80446	20	<input type="checkbox"/>	Hot-Mix Asphalt - Longitudinal Joint Sealant	Nov. 1, 2022	
	80438	21	<input type="checkbox"/>	Illinois Works Apprenticeship Initiative – State Funded Contracts	June 2, 2021	Sept. 2, 2021
	80045	22	<input type="checkbox"/>	Material Transfer Device	June 15, 1999	Jan. 1, 2022
	80441	23	<input checked="" type="checkbox"/>	Performance Graded Asphalt Binder	Jan. 1, 2023	
*	34261	24	<input type="checkbox"/>	Railroad Protective Liability Insurance	Dec. 1, 1986	Jan. 1, 2022
	80445	25	<input type="checkbox"/>	Seeding	Nov. 1, 2022	
	80340	26	<input type="checkbox"/>	Speed Display Trailer	April 2, 2014	Jan. 1, 2022
	80127	27	<input type="checkbox"/>	Steel Cost Adjustment	April 2, 2004	Jan. 1, 2022
	80397	28	<input type="checkbox"/>	Subcontractor and DBE Payment Reporting	April 2, 2018	
	80391	29	<input type="checkbox"/>	Subcontractor Mobilization Payments	Nov. 2, 2017	April 1, 2019
	80437	30	<input type="checkbox"/>	Submission of Payroll Records	April 1, 2021	Nov. 1, 2022
	80435	31	<input checked="" type="checkbox"/>	Surface Testing of Pavements – IRI	Jan. 1, 2021	Jan. 1, 2023
	80410	32	<input type="checkbox"/>	Traffic Spotters	Jan. 1, 2019	
*	20338	33	<input type="checkbox"/>	Training Special Provisions	Oct. 15, 1975	Sept. 2, 2021
	80429	34	<input type="checkbox"/>	Ultra-Thin Bonded Wearing Course	April 1, 2020	Jan. 1, 2022
	80439	35	<input type="checkbox"/>	Vehicle and Equipment Warning Lights	Nov. 1, 2021	Nov. 1, 2022
	80440	36	<input type="checkbox"/>	Waterproofing Membrane System	Nov. 1, 2021	
	80302	37	<input type="checkbox"/>	Weekly DBE Trucking Reports	June 2, 2012	Nov. 1, 2021
	80427	38	<input type="checkbox"/>	Work Zone Traffic Control Devices	Mar. 2, 2020	
*	80071	39	<input type="checkbox"/>	Working Days	Jan. 1, 2002	

Highlighted items indicate a new or revised special provision for the letting.

An * indicates the special provision requires additional information from the designer, which needs to be submitted separately. The Project Coordination and Implementation Section will then include the information in the applicable special provision.

The following special provisions have been deleted from use.

<u>File Name</u>	<u>Special Provision Title</u>	<u>Effective</u>	<u>Revised</u>
50481	Building Removal-Case II (Non-Friable Asbestos)	Sept. 1, 1990	April 1, 2010
50491	Building Removal-Case III (Friable Asbestos)	Sept. 1, 1990	April 1, 2010

The following special provisions are in the 2023 Supplemental Specifications and Recurring Special Provisions.

<u>File Name</u>	<u>Special Provision Title</u>	<u>New Location(s)</u>	<u>Effective</u>	<u>Revised</u>
80293	Concrete Box Culverts with Skews > 30 Degrees and Design Fills ≤ 5 Feet	Articles 540.04 & 540.06	April 1, 2012	July 1, 2016
80311	Concrete End Sections for Pipe Culverts	Articles 540.07, 542.01, 542.02, 542.07, 542.11 & 542.12	Jan. 1, 2013	April 1, 2016
80422	High Tension Cable Median Barrier	Articles 644.02, 644.05, 782.01, 782.04, 782.07 & 1097.02	Jan. 1, 2020	Jan. 1, 2022
80442	Hot-Mix Asphalt	Articles 1030.09 & 1030.10	Jan. 1, 2022	Aug. 1, 2022
80444	Hot-Mix Asphalt – Patching	Errata – Article 442.08(b)	April 1, 2022	
80411	Luminaires, LED	Articles 801.05(a), 821.02(d), 821.03, 821.08 & 1067.01-1067.06	April 1, 2019	Jan. 1, 2022
80418	Mechanically Stabilized Earth Retaining Walls	Articles 1003.07 & 1004.06	Nov. 1, 2019	Nov. 1, 2020
80430	Portland Cement Concrete – Haul Time	Article 1020.11(a)(7)	July 1, 2020	
80395	Sloped Metal End Section for Pipe Culverts	Articles 540.07, 542.01, 542.02, 542.07, 542.11 & 542.12	Jan. 1, 2018	
80318	Traversable Pipe Grate for Concrete End Sections	Articles 540.04, 540.07, 540.08 & 542.01, 542.02, 542.07, 542.11 & 542.12	Jan. 1, 2013	Jan. 1, 2018

CONSTRUCTION AIR QUALITY – DIESEL RETROFIT (BDE)

Effective: June 1, 2010

Revised: November 1, 2014

The reduction of emissions of particulate matter (PM) for off-road equipment shall be accomplished by installing retrofit emission control devices. The term “equipment” refers to diesel fuel powered devices rated at 50 hp and above, to be used on the jobsite in excess of seven calendar days over the course of the construction period on the jobsite (including rental equipment).

Contractor and subcontractor diesel powered off-road equipment assigned to the contract shall be retrofitted using the phased in approach shown below. Equipment that is of a model year older than the year given for that equipment’s respective horsepower range shall be retrofitted:

Effective Dates	Horsepower Range	Model Year
June 1, 2010 ^{1/}	600-749	2002
	750 and up	2006
June 1, 2011 ^{2/}	100-299	2003
	300-599	2001
	600-749	2002
	750 and up	2006
June 1, 2012 ^{2/}	50-99	2004
	100-299	2003
	300-599	2001
	600-749	2002
	750 and up	2006

1/ Effective dates apply to Contractor diesel powered off-road equipment assigned to the contract.

2/ Effective dates apply to Contractor and subcontractor diesel powered off-road equipment assigned to the contract.

The retrofit emission control devices shall achieve a minimum PM emission reduction of 50 percent and shall be:

- a) Included on the U.S. Environmental Protection Agency (USEPA) *Verified Retrofit Technology List* (<http://www.epa.gov/cleandiesel/verification/verif-list.htm>), or verified by the California Air Resources Board (CARB) (<http://www.arb.ca.gov/diesel/verdev/vt/cvt.htm>); or
- b) Retrofitted with a non-verified diesel retrofit emission control device if verified retrofit emission control devices are not available for equipment proposed to be used on the project, and if the Contractor has obtained a performance certification from the retrofit

device manufacturer that the emission control device provides a minimum PM emission reduction of 50 percent.

Note: Large cranes (Crawler mounted cranes) which are responsible for critical lift operations are exempt from installing retrofit emission control devices if such devices adversely affect equipment operation.

Diesel powered off-road equipment with engine ratings of 50 hp and above, which are unable to be retrofitted with verified emission control devices or if performance certifications are not available which will achieve a minimum 50 percent PM reduction, may be granted a waiver by the Department if documentation is provided showing good faith efforts were made by the Contractor to retrofit the equipment.

Construction shall not proceed until the Contractor submits a certified list of the diesel powered off-road equipment that will be used, and as necessary, retrofitted with emission control devices. The list(s) shall include (1) the equipment number, type, make, Contractor/rental company name; and (2) the emission control devices make, model, USEPA or CARB verification number, or performance certification from the retrofit device manufacturer. Equipment reported as fitted with emissions control devices shall be made available to the Engineer for visual inspection of the device installation, prior to being used on the jobsite.

The Contractor shall submit an updated list of retrofitted off-road construction equipment as retrofitted equipment changes or comes on to the jobsite. The addition or deletion of any diesel powered equipment shall be included on the updated list.

If any diesel powered off-road equipment is found to be in non-compliance with any portion of this special provision, the Engineer will issue the Contractor a diesel retrofit deficiency deduction.

Any costs associated with retrofitting any diesel powered off-road equipment with emission control devices shall be considered as included in the contract unit prices bid for the various items of work involved and no additional compensation will be allowed. The Contractor's compliance with this notice and any associated regulations shall not be grounds for a claim.

Diesel Retrofit Deficiency Deduction

When the Engineer determines that a diesel retrofit deficiency exists, a daily monetary deduction will be imposed for each calendar day or fraction thereof the deficiency continues to exist. The calendar day(s) will begin when the time period for correction is exceeded and end with the Engineer's written acceptance of the correction. The daily monetary deduction will be \$1,000.00 for each deficiency identified.

The deficiency will be based on lack of diesel retrofit emissions control.

If a Contractor accumulates three diesel retrofit deficiency deductions for the same piece of equipment in a contract period, the Contractor will be shutdown until the deficiency is corrected.

Such a shutdown will not be grounds for any extension of the contract time, waiver of penalties, or be grounds for any claim.

80261

COMPENSABLE DELAY COSTS (BDE)

Effective: June 2, 2017

Revised: April 1, 2019

Revise Article 107.40(b) of the Standard Specifications to read:

“(b) Compensation. Compensation will not be allowed for delays, inconveniences, or damages sustained by the Contractor from conflicts with facilities not meeting the above definition; or if a conflict with a utility in an unanticipated location does not cause a shutdown of the work or a documentable reduction in the rate of progress exceeding the limits set herein. The provisions of Article 104.03 notwithstanding, compensation for delays caused by a utility in an unanticipated location will be paid according to the provisions of this Article governing minor and major delays or reduced rate of production which are defined as follows.

- (1) Minor Delay. A minor delay occurs when the work in conflict with the utility in an unanticipated location is completely stopped for more than two hours, but not to exceed two weeks.
- (2) Major Delay. A major delay occurs when the work in conflict with the utility in an unanticipated location is completely stopped for more than two weeks.
- (3) Reduced Rate of Production Delay. A reduced rate of production delay occurs when the rate of production on the work in conflict with the utility in an unanticipated location decreases by more than 25 percent and lasts longer than seven calendar days.”

Revise Article 107.40(c) of the Standard Specifications to read:

“(c) Payment. Payment for Minor, Major, and Reduced Rate of Production Delays will be made as follows.

- (1) Minor Delay. Labor idled which cannot be used on other work will be paid for according to Article 109.04(b)(1) and (2) for the time between start of the delay and the minimum remaining hours in the work shift required by the prevailing practice in the area.

Equipment idled which cannot be used on other work, and which is authorized to standby on the project site by the Engineer, will be paid for according to Article 109.04(b)(4).

- (2) Major Delay. Labor will be the same as for a minor delay.

Equipment will be the same as for a minor delay, except Contractor-owned equipment will be limited to two weeks plus the cost of move-out to either the

Contractor's yard or another job and the cost to re-mobilize, whichever is less. Rental equipment may be paid for longer than two weeks provided the Contractor presents adequate support to the Department (including lease agreement) to show retaining equipment on the job is the most economical course to follow and in the public interest.

- (3) Reduced Rate of Production Delay. The Contractor will be compensated for the reduced productivity for labor and equipment time in excess of the 25 percent threshold for that portion of the delay in excess of seven calendar days. Determination of compensation will be in accordance with Article 104.02, except labor and material additives will not be permitted.

Payment for escalated material costs, escalated labor costs, extended project overhead, and extended traffic control will be determined according to Article 109.13.”

Revise Article 108.04(b) of the Standard Specifications to read:

“(b) No working day will be charged under the following conditions.

- (1) When adverse weather prevents work on the controlling item.
- (2) When job conditions due to recent weather prevent work on the controlling item.
- (3) When conduct or lack of conduct by the Department or its consultants, representatives, officers, agents, or employees; delay by the Department in making the site available; or delay in furnishing any items required to be furnished to the Contractor by the Department prevents work on the controlling item.
- (4) When delays caused by utility or railroad adjustments prevent work on the controlling item.
- (5) When strikes, lock-outs, extraordinary delays in transportation, or inability to procure critical materials prevent work on the controlling item, as long as these delays are not due to any fault of the Contractor.
- (6) When any condition over which the Contractor has no control prevents work on the controlling item.”

Revise Article 109.09(f) of the Standard Specifications to read:

“(f) Basis of Payment. After resolution of a claim in favor of the Contractor, any adjustment in time required for the work will be made according to Section 108. Any adjustment in the costs to be paid will be made for direct labor, direct materials, direct equipment, direct jobsite overhead, direct offsite overhead, and other direct costs allowed by the resolution. Adjustments in costs will not be made for interest charges, loss of anticipated profit, undocumented loss of efficiency, home office overhead and unabsorbed overhead

other than as allowed by Article 109.13, lost opportunity, preparation of claim expenses and other consequential indirect costs regardless of method of calculation.

The above Basis of Payment is an essential element of the contract and the claim cost recovery of the Contractor shall be so limited.”

Add the following to Section 109 of the Standard Specifications.

“109.13 Payment for Contract Delay. Compensation for escalated material costs, escalated labor costs, extended project overhead, and extended traffic control will be allowed when such costs result from a delay meeting the criteria in the following table.

Contract Type	Cause of Delay	Length of Delay
Working Days	Article 108.04(b)(3) or Article 108.04(b)(4)	No working days have been charged for two consecutive weeks.
Completion Date	Article 108.08(b)(1) or Article 108.08(b)(7)	The Contractor has been granted a minimum two week extension of contract time, according to Article 108.08.

Payment for each of the various costs will be according to the following.

- (a) Escalated Material and/or Labor Costs. When the delay causes work, which would have otherwise been completed, to be done after material and/or labor costs have increased, such increases will be paid. Payment for escalated material costs will be limited to the increased costs substantiated by documentation furnished by the Contractor. Payment for escalated labor costs will be limited to those items in Article 109.04(b)(1) and (2), except the 35 percent and 10 percent additives will not be permitted.
- (b) Extended Project Overhead. For the duration of the delay, payment for extended project overhead will be paid as follows.
 - (1) Direct Jobsite and Offsite Overhead. Payment for documented direct jobsite overhead and documented direct offsite overhead, including onsite supervisory and administrative personnel, will be allowed according to the following table.

Original Contract Amount	Supervisory and Administrative Personnel
Up to \$5,000,000	One Project Superintendent
Over \$ 5,000,000 - up to \$25,000,000	One Project Manager, One Project Superintendent or Engineer, and One Clerk
Over \$25,000,000 - up to \$50,000,000	One Project Manager, One Project Superintendent, One Engineer, and

	One Clerk
Over \$50,000,000	One Project Manager, Two Project Superintendents, One Engineer, and One Clerk

(2) Home Office and Unabsorbed Overhead. Payment for home office and unabsorbed overhead will be calculated as 8 percent of the total delay cost.

(c) Extended Traffic Control. Traffic control required for an extended period of time due to the delay will be paid for according to Article 109.04.

When an extended traffic control adjustment is paid under this provision, an adjusted unit price as provided for in Article 701.20(a) for increase or decrease in the value of work by more than ten percent will not be paid.

Upon payment for a contract delay under this provision, the Contractor shall assign subrogation rights to the Department for the Department's efforts of recovery from any other party for monies paid by the Department as a result of any claim under this provision. The Contractor shall fully cooperate with the Department in its efforts to recover from another party any money paid to the Contractor for delay damages under this provision."

WORK ZONE TRAFFIC CONTROL DEVICES (BDE)

Effective: March 2, 2020

Add the following to Article 701.03 of the Standard Specifications:

“(q) Temporary Sign Supports 1106.02”

Revise the third paragraph of Article 701.14 of the Standard Specifications to read:

“For temporary sign supports, the Contractor shall provide a FHWA eligibility letter for each device used on the contract. The letter shall provide information for the set-up and use of the device as well as a detailed drawing of the device. The signs shall be supported within 20 degrees of vertical. Weights used to stabilize signs shall be attached to the sign support per the manufacturer’s specifications.”

Revise the first paragraph of Article 701.15 of the Standard Specifications to read:

“**701.15 Traffic Control Devices.** For devices that must meet crashworthiness standards, the Contractor shall provide a manufacturer’s self-certification or a FHWA eligibility letter for each Category 1 device and a FHWA eligibility letter for each Category 2 and Category 3 device used on the contract. The self-certification or letter shall provide information for the set-up and use of the device as well as a detailed drawing of the device.”

Revise the first six paragraphs of Article 1106.02 of the Standard Specifications to read:

“**1106.02 Devices.** Work zone traffic control devices and combinations of devices shall meet crashworthiness standards for their respective categories. The categories are as follows.

Category 1 includes small, lightweight, channelizing and delineating devices that have been in common use for many years and are known to be crashworthy by crash testing of similar devices or years of demonstrable safe performance. These include cones, tubular markers, plastic drums, and delineators, with no attachments (e.g. lights). Category 1 devices manufactured after December 31, 2019 shall be MASH-16 compliant. Category 1 devices manufactured on or before December 31, 2019, and compliant with NCHRP 350 or MASH 2009, may be used on contracts let before December 31, 2024.

Category 2 includes devices that are not expected to produce significant vehicular velocity change but may otherwise be hazardous. These include vertical panels with lights, barricades, temporary sign supports, and Category 1 devices with attachments (e.g. drums with lights). Category 2 devices manufactured after December 31, 2019 shall be MASH-16 compliant. Category 2 devices manufactured on or before December 31, 2019, and compliant with NCHRP 350 or MASH 2009, may be used on contracts let before December 31, 2024.

Category 3 includes devices that are expected to cause significant velocity changes or other potentially harmful reactions to impacting vehicles. These include crash cushions (impact

attenuators), truck mounted attenuators, and other devices not meeting the definitions of Category 1 or 2. Category 3 devices manufactured after December 31, 2019 shall be MASH-16 compliant. Category 3 devices manufactured on or before December 31, 2019, and compliant with NCHRP 350 or MASH 2009, may be used on contracts let before December 31, 2029. Category 3 devices shall be crash tested for Test Level 3 or the test level specified.

Category 4 includes portable or trailer-mounted devices such as arrow boards, changeable message signs, temporary traffic signals, and area lighting supports. It is preferable for Category 4 devices manufactured after December 31, 2019 to be MASH-16 compliant; however, there are currently no crash tested devices in this category, so it remains exempt from the NCHRP 350 or MASH compliance requirement.

For each type of device, when no more than one MASH-16 compliant is available, an NCHRP 350 or MASH-2009 compliant device may be used, even if manufactured after December 31, 2019.”

Revise Articles 1106.02(g), 1106.02(k), and 1106.02(l) to read:

“(g) Truck Mounted/Trailer Mounted Attenuators. The attenuator shall be approved for use at Test Level 3. Test Level 2 may be used for normal posted speeds less than or equal to 45 mph.

(k) Temporary Water Filled Barrier. The water filled barrier shall be a lightweight plastic shell designed to accept water ballast and be on the Department’s qualified product list.

Shop drawings shall be furnished by the manufacturer and shall indicate the deflection of the barrier as determined by acceptance testing; the configuration of the barrier in that test; and the vehicle weight, velocity, and angle of impact of the deflection test. The Engineer shall be provided one copy of the shop drawings.

(l) Movable Traffic Barrier. The movable traffic barrier shall be on the Department’s qualified product list.

Shop drawings shall be furnished by the manufacturer and shall indicate the deflection of the barrier as determined by acceptance testing; the configuration of the barrier in that test; and the vehicle weight, velocity, and angle of impact of the deflection test. The Engineer shall be provided one copy of the shop drawings. The barrier shall be capable of being moved on and off the roadway on a daily basis.”

APPENDIX A
LOCATION MAPS

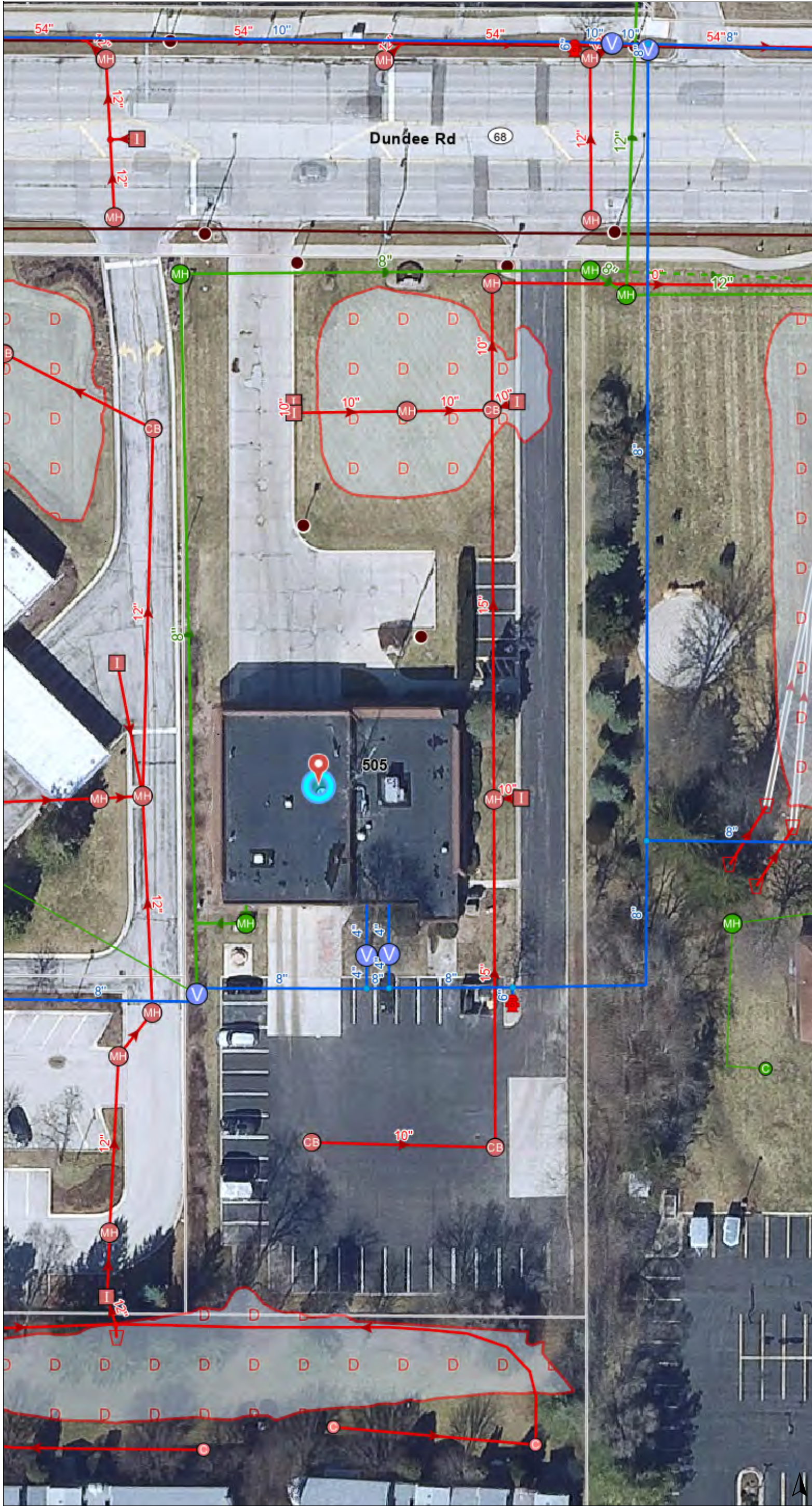

Legend

- Water Utilities
 - Hydrant
 - Water Fitting
 - Water Valve
 - Water Meter
 - Water Main
 - Active
- Sanitary Utilities
 - Sanitary Manhole
 - Sanitary Cleanout
 - Sanitary Lateral
 - Active
 - Abandoned
 - Sanitary Main
 - Active
- Storm Utilities
 - Storm Catch Basin
 - Storm Inlet
 - Storm Manhole
 - Storm Fitting
 - Storm Cleanout
 - Storm Flared End Section
 - Storm Main
 - Active
 - Retention or Detention Area
 - Detention
 - Storm Open Conveyance Channel
 -
- Street Light and Electrical Utilities
 - Street Light Bulb
 - Street Light Electric Line
 - Active

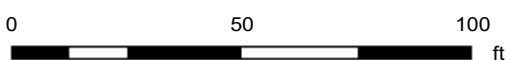

Print Date: 12/22/2022

Notes

Aerial Map & Utilities

Disclaimer: The GIS Consortium and MGP Inc. are not liable for any use, misuse, modification or disclosure of any map provided under applicable law. This map is for general information purposes only. Although the information is believed to be generally accurate, errors may exist and the user should independently confirm for accuracy. The map does not constitute a regulatory determination and is not a base for engineering design. A Registered Land Surveyor should be consulted to determine precise location boundaries on the ground.

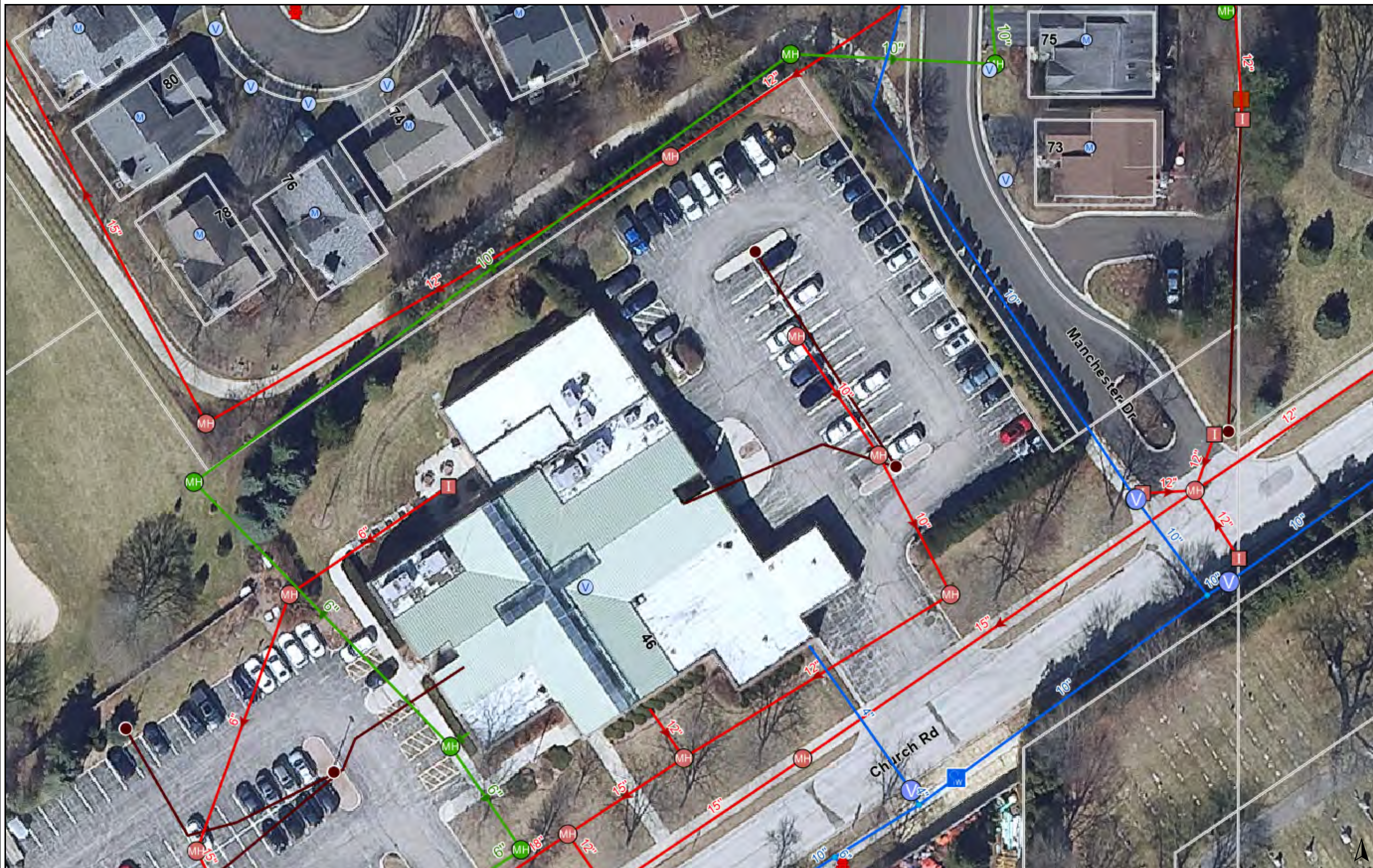

Legend

- Water Utilities
 - Hydrant
 - Water Fitting
 - Water Valve Open
 - Water Service Valve Open
 - Water Meter
 - Water Main Active
 - Water Sensor
- Sanitary Utilities
 - Sanitary Manhole
 - Sanitary Main Active
- Storm Utilities
 - Storm Inlet
 - Storm Manhole
 - Storm Main Active
- Street Light and Electrical Utilities
 - Street Light Bulb
 - Street Light Transformer
 - Street Light Electric Line Active

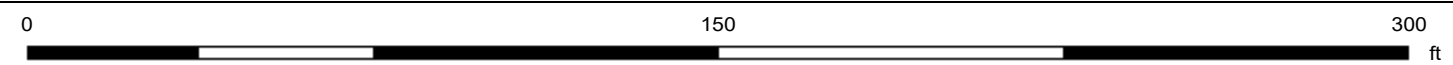

Print Date: 12/22/2022

Notes

Aerial Map & Utilities

Disclaimer: The GIS Consortium and MGP Inc. are not liable for any use, misuse, modification or disclosure of any map provided under applicable law. This map is for general information purposes only. Although the information is believed to be generally accurate, errors may exist and the user should independently confirm for accuracy. The map does not constitute a regulatory determination and is not a base for engineering design. A Registered Land Surveyor should be consulted to determine precise location boundaries on the ground.

APPENDIX B

IDOT HIGHWAY STANDARDS & DISTRICT SPECIFIC STANDARDS

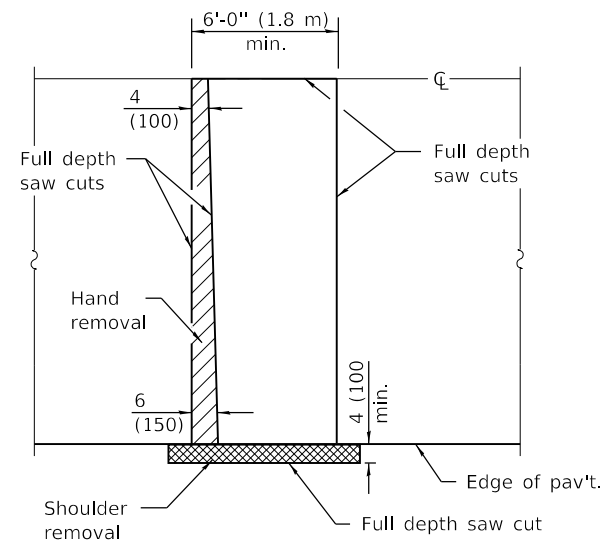

PAVEMENT SAWING DETAIL

(HMA SHOULDER)

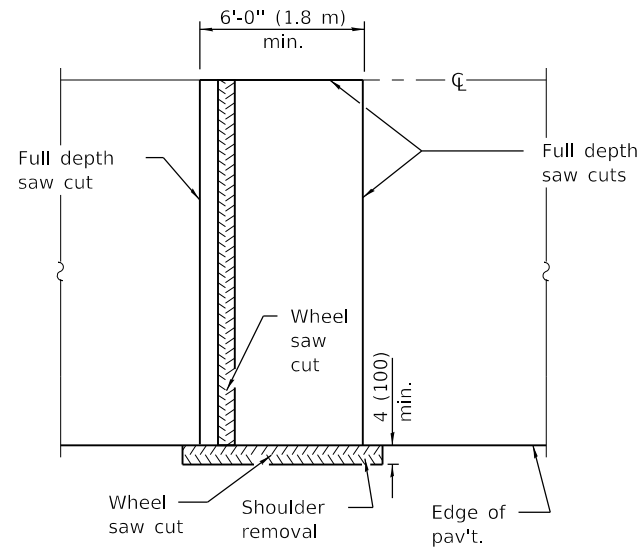

ALTERNATE SAWING DETAIL

(HMA SHOULDER)

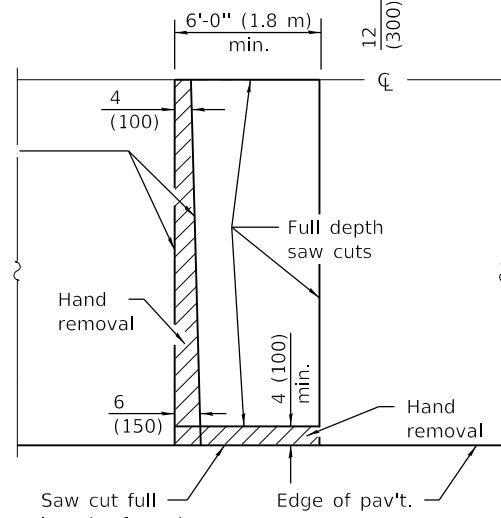

PAVEMENT SAWING DETAIL

(PCC SHOULDER)

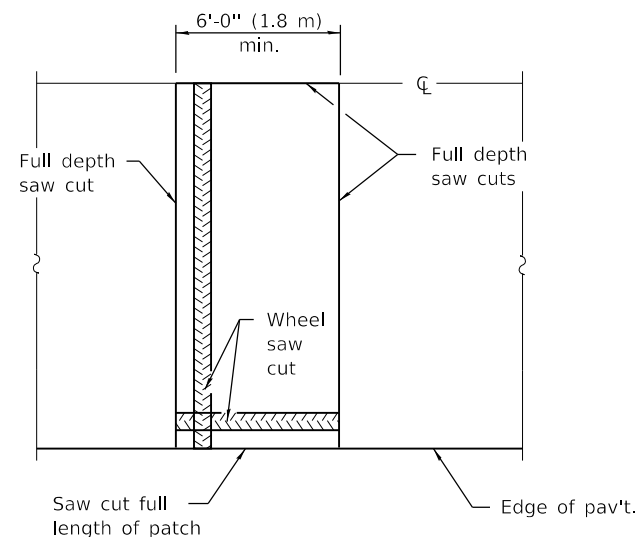

ALTERNATE SAWING DETAIL

(PCC SHOULDER)

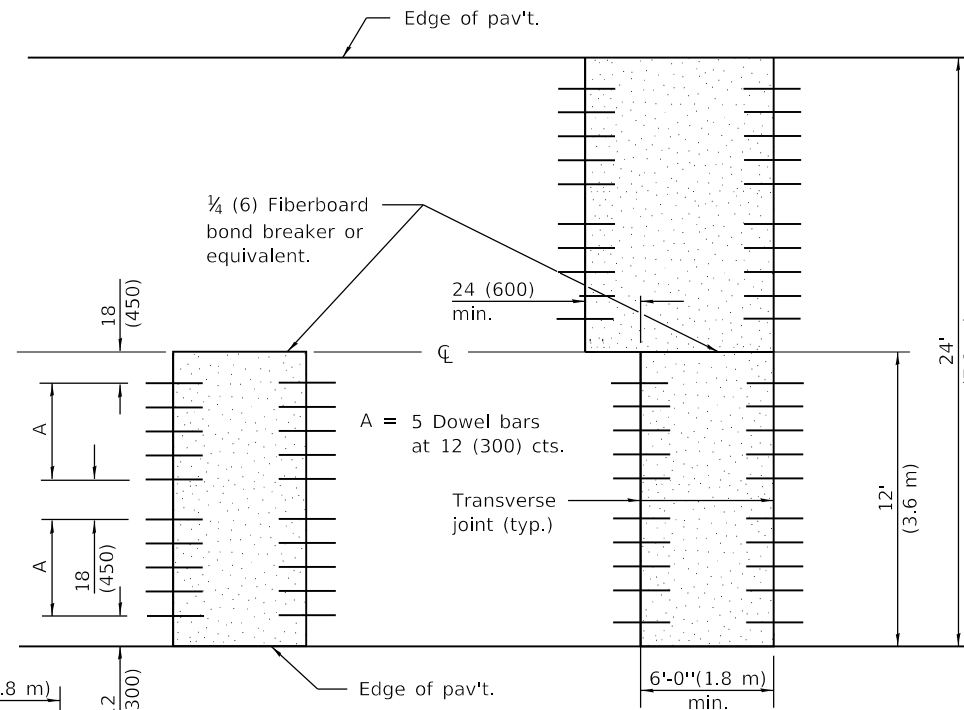

12' (3.6 m) WIDE LANES

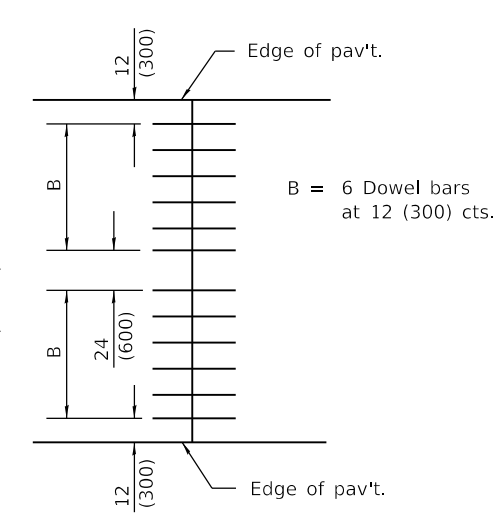

14' (4.2 m) WIDE RAMP

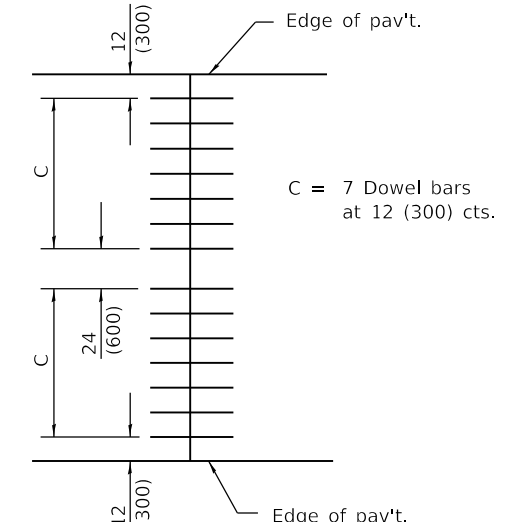

16' (4.8 m) WIDE RAMP

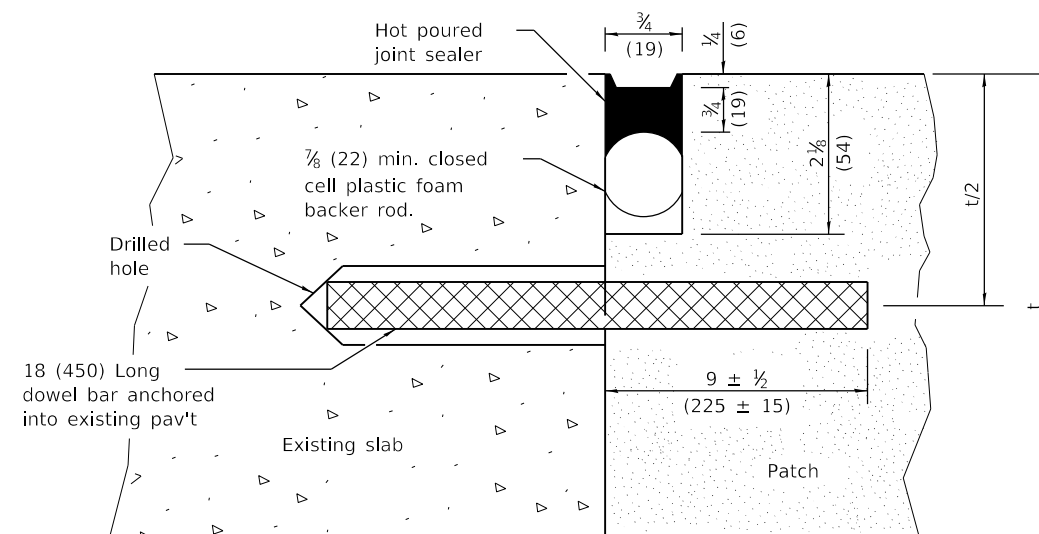

TRANSVERSE JOINT

DOWEL BAR TABLE		
PAVEMENT THICKNESS	DOWEL BAR DIAMETER	HOLE DIAMETER
10 (250) or greater	1 1/2 (38)	1 3/8 (41)
8 (200) thru 9.99 (249)	1 1/4 (32)	1 3/8 (35)
Less than 8 (200)	1 (25)	1 1/8 (29)

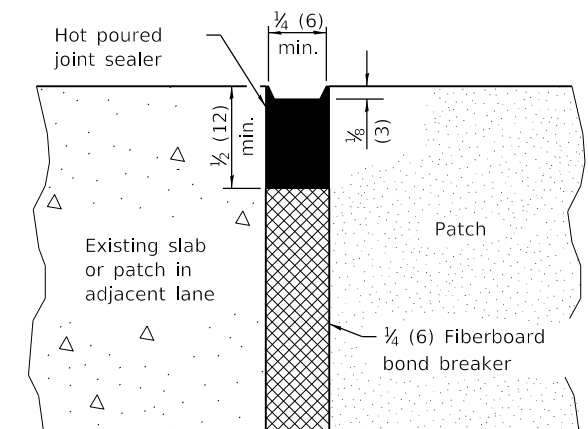

CENTERLINE JOINT

GENERAL NOTES

The transverse joints for Class B patches shall align with joints or cracks in the adjacent lane whenever possible.

See Standard 420701 for details of welded wire reinforcement.

All dimensions are in inches (millimeters) unless otherwise shown.

DATE	REVISIONS
1-1-19	Revised reference to Standard 420701 in General Notes.
1-1-18	Revised DOWEL BAR TABLE.

CLASS B PATCHES

(Sheet 1 of 2)

STANDARD 442101-09

Illinois Department of Transportation

PASSED January 1, 2019

ENGINEER OF POLICY AND PROCEDURES

APPROVED January 1, 2019

ENGINEER OF DESIGN AND ENVIRONMENT

ISSUED 1-1-19

TRANSVERSE EXPANSION JOINTS

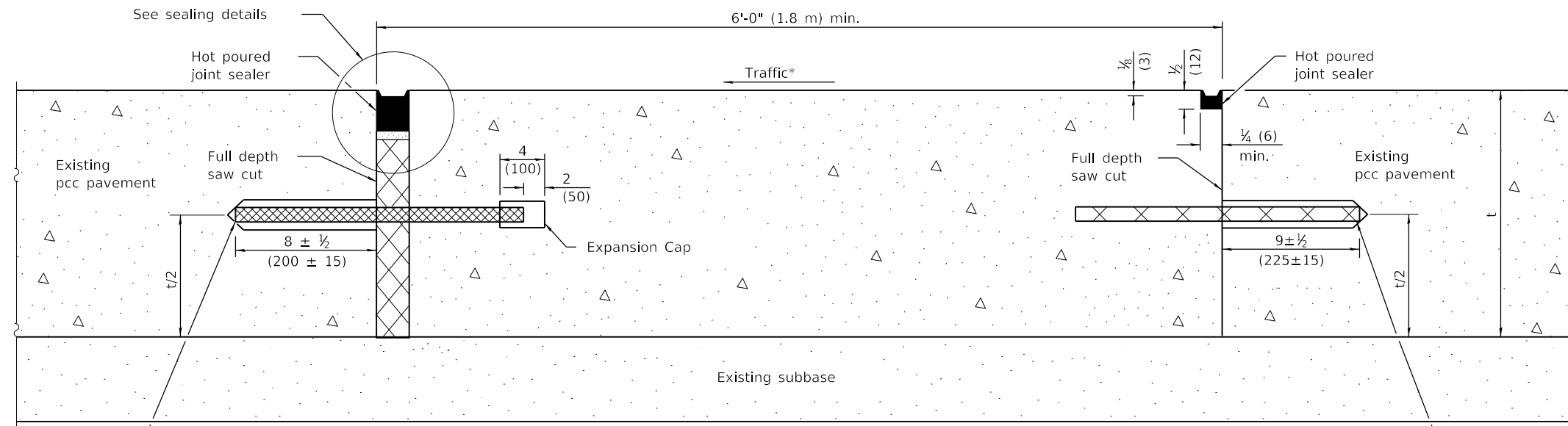

18 (450) Long dowel bars anchored into existing pavement at 12 (300) cts.

METHOD I
(Without Resurfacing)

No. 10x18 (No. 32x450) Tie bars anchored into existing pavement at 12 (300) cts.

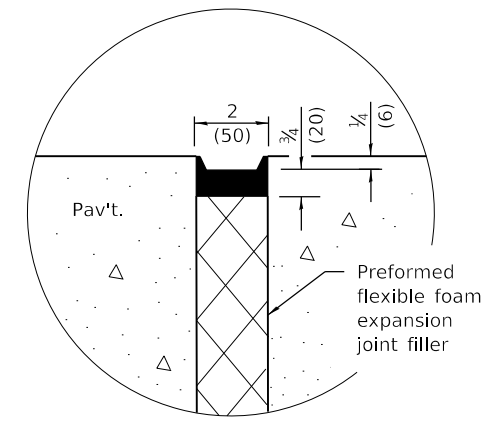

SEALING DETAIL

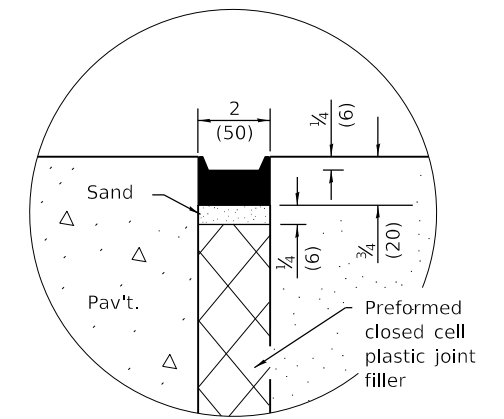

SEALING DETAIL

NOTE

* When re-establishing a transverse expansion joint on a two-lane, two-way road, reverse the orientation of the dowel bars with respect to traffic for one of the patches such that the joint will be continuous across both lanes.

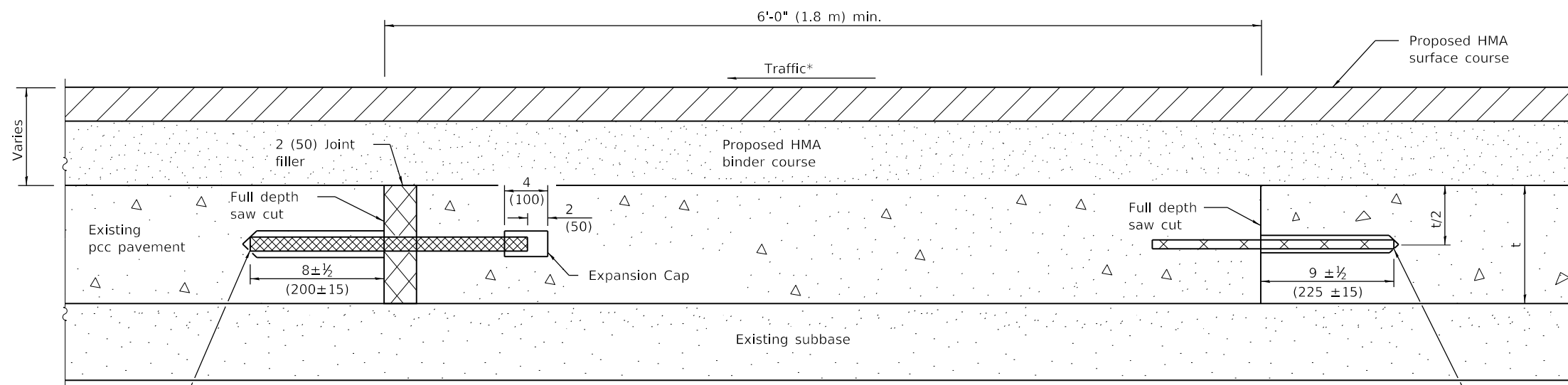

18 (450) Long dowel bars anchored into existing pavement at 12 (300) cts.

METHOD II
(With Resurfacing)

No. 10x18 (No. 32x450) Tie bars anchored into existing pavement at 12 (300) cts.

Illinois Department of Transportation

PASSED January 1, 2019
Michael Bond
 ENGINEER OF POLICY AND PROCEDURES

APPROVED January 1, 2019
John E. ...
 ENGINEER OF DESIGN AND ENVIRONMENT

ISSUED 1-1-97

CLASS B PATCHES

(Sheet 2 of 2)

STANDARD 442101-09

CLASS C

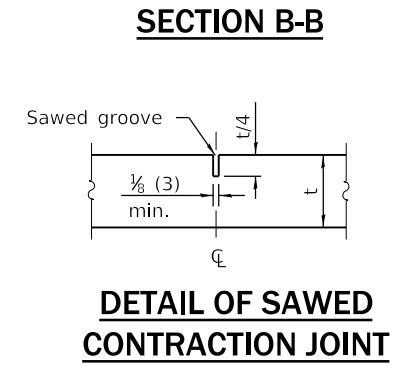
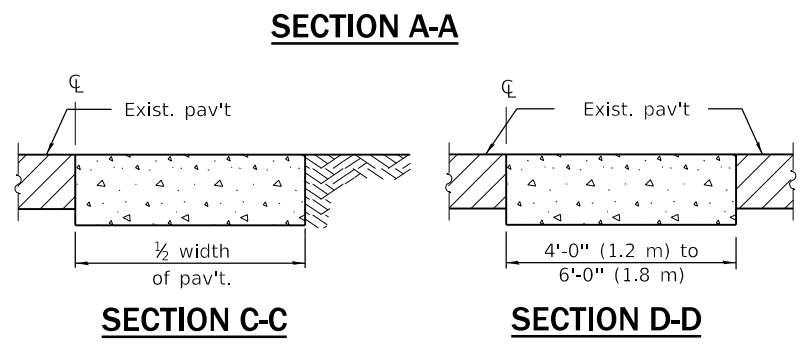
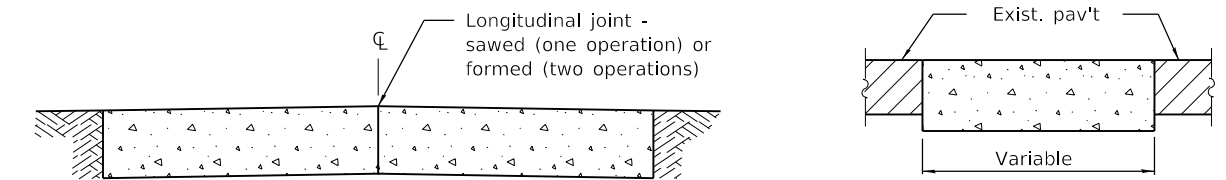
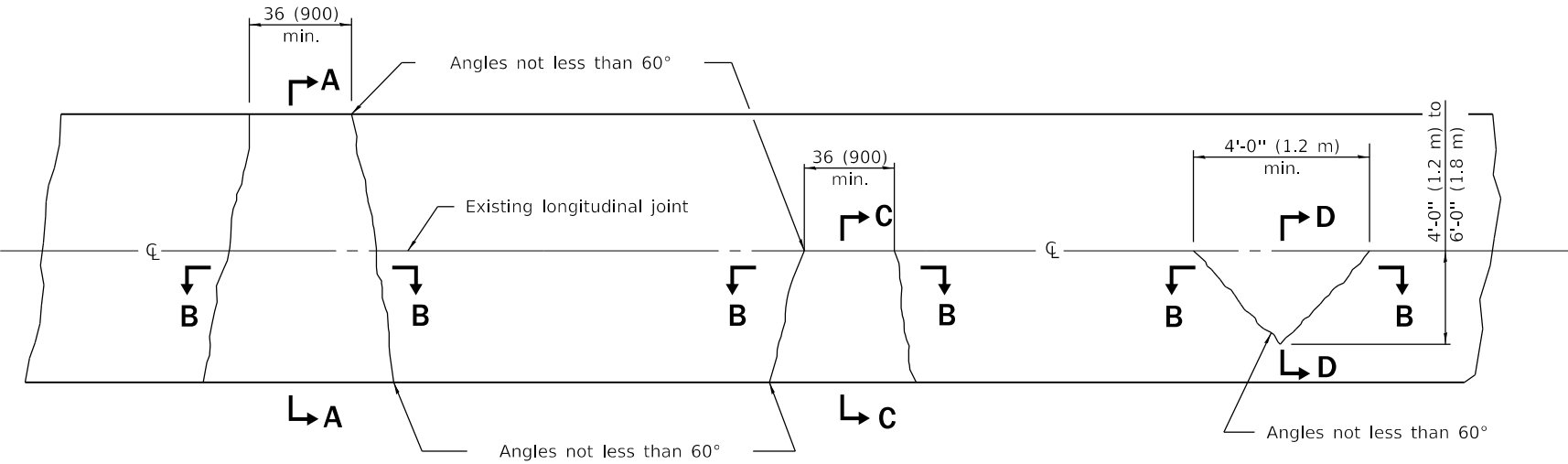

Note:
Longitudinal joints shall be as detailed on Standard 420001, except tie bars are not required for patches 20'-0" (6.0 m) or less in length.

CLASS D

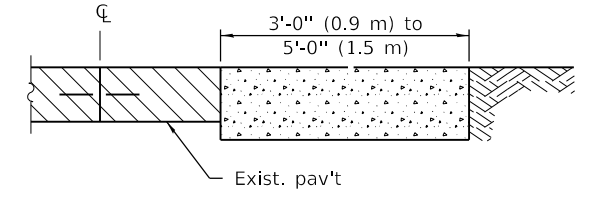
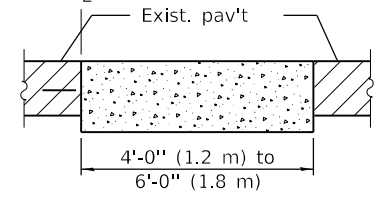
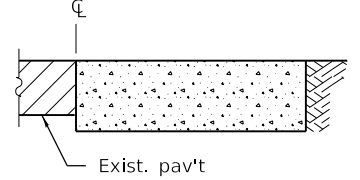
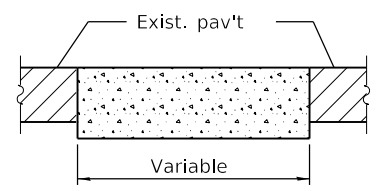
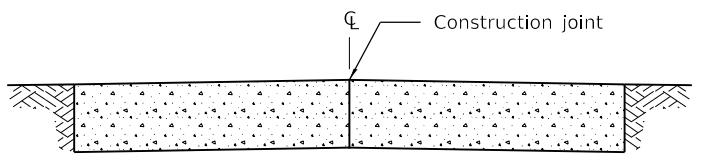
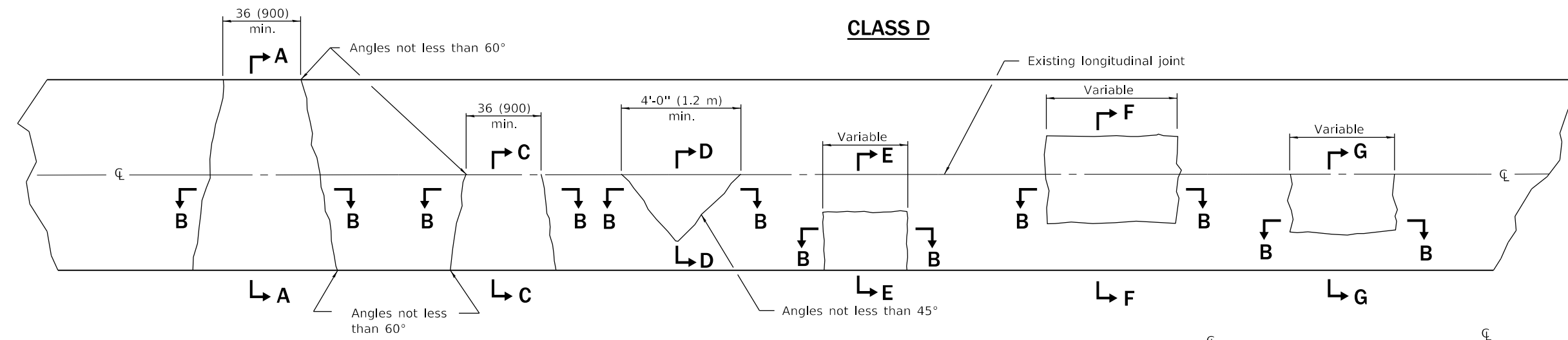

SECTION A-A
(Built in two operations)

SECTION B-B

SECTION C-C

SECTION D-D

SECTION E-E

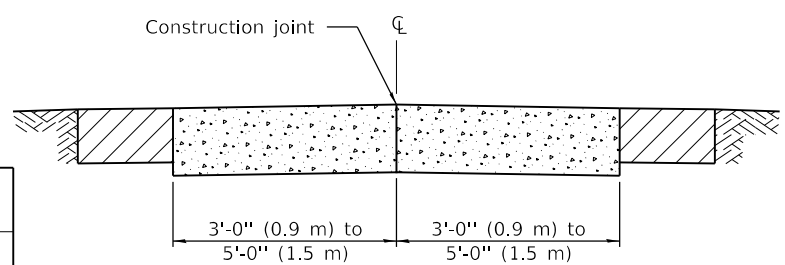

SECTION F-F
(Built in two operations)

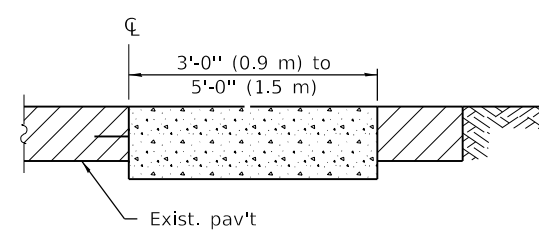

SECTION G-G

GENERAL NOTES
Existing tie bars shall be either cut or removed. Marginal bars shall be cut.
All dimensions are in inches (millimeters) unless otherwise shown.

Illinois Department of Transportation

PASSED January 1, 2008
ENGINEER OF POLICY AND PROCEDURES

APPROVED January 1, 2008
ENGINEER OF DESIGN AND ENVIRONMENT

ISSUED 1-1-97

DATE	REVISIONS
1-1-08	Switched units to English (metric).
1-1-07	Revised Note for Class C patches.

CLASS C and D PATCHES

STANDARD 442201-03

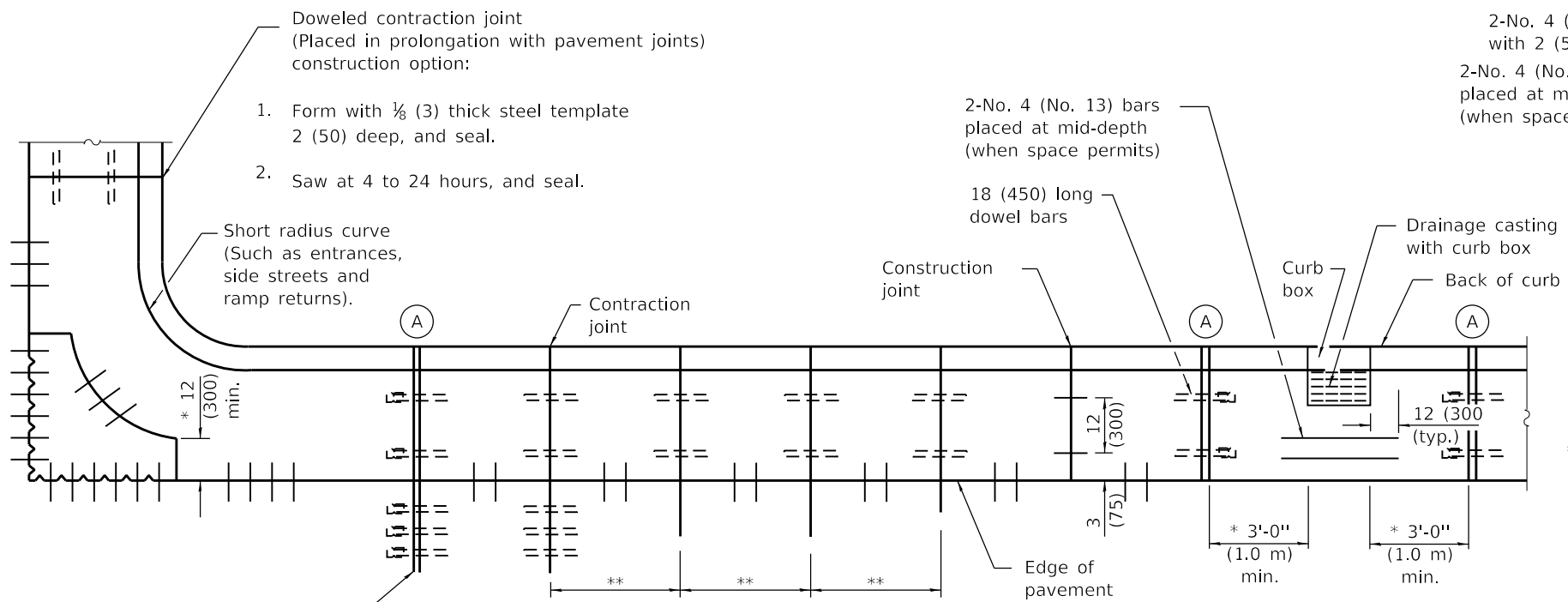

PLAN
ADJACENT TO PCC PAVEMENT OR PCC BASE COURSE

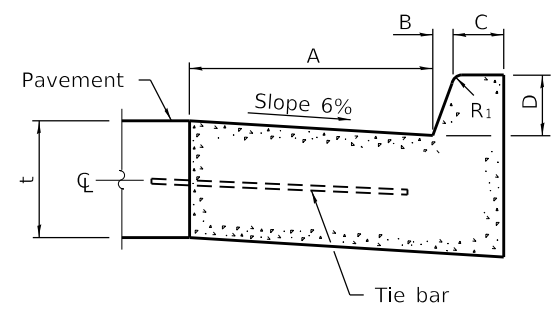

BARRIER CURB

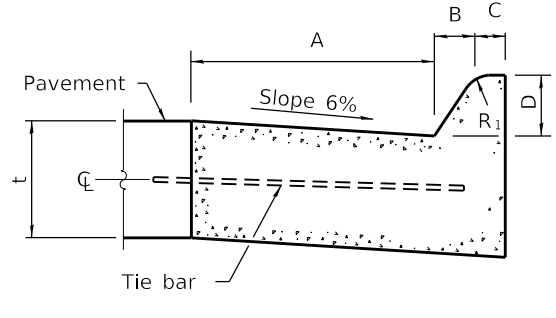

MOUNTABLE CURB

TABLE OF DIMENSIONS BARRIER CURB					
TYPE	A	B	C	D	R ₁
B-6.06 *	6	1	6	6	1
(B-15.15)	(150)	(25)	(150)	(150)	(25)
B-6.12	12	1	6	6	1
(B-15.3)	(300)	(25)	(150)	(150)	(25)
B-6.18	18	1	6	6	1
(B-15.45)	(450)	(25)	(150)	(150)	(25)
B-6.24	24	1	6	6	1
(B-15.60)	(600)	(25)	(150)	(150)	(25)
B-9.12	12	2	5	9	1
(B-22.30)	(300)	(50)	(125)	(225)	(25)
B-9.18	18	2	5	9	1
(B-22.45)	(450)	(50)	(125)	(225)	(25)
B-9.24	24	2	5	9	1
(B-22.60)	(600)	(50)	(125)	(225)	(25)

* For corner islands only.

TABLE OF DIMENSIONS MOUNTABLE CURB						
TYPE	A	B	C	D	R ₁	R ₂
M-2.06	6	2	4	2	3	2
(M-5.15)	(150)	(50)	(100)	(50)	(75)	(50)
M-2.12	12	2	4	2	3	2
(M-5.30)	(300)	(50)	(100)	(50)	(75)	(50)
M-4.06	6	4	3	4	3	NA
(M-10.15)	(150)	(100)	(75)	(100)	(75)	NA
M-4.12	12	4	3	4	3	NA
(M-10.30)	(300)	(100)	(75)	(100)	(75)	NA
M-4.18	18	4	3	4	3	NA
(M-10.45)	(450)	(100)	(75)	(100)	(75)	NA
M-4.24	24	4	3	4	3	NA
(M-10.60)	(600)	(100)	(75)	(100)	(75)	NA
M-6.06	6	6	2	6	2	NA
(M-15.15)	(150)	(150)	(50)	(150)	(50)	NA
M-6.12	12	6	2	6	2	NA
(M-15.30)	(300)	(150)	(50)	(150)	(50)	NA
M-6.18	18	6	2	6	2	NA
(M-15.45)	(450)	(150)	(50)	(150)	(50)	NA
M-6.24	24	6	2	6	2	NA
(M-15.60)	(600)	(150)	(50)	(150)	(50)	NA

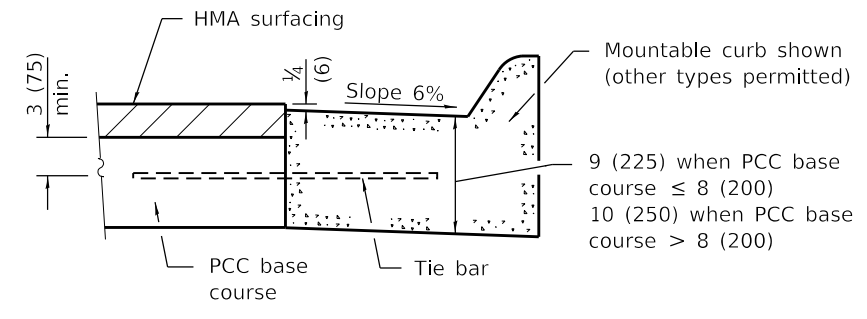

ADJACENT TO PCC BASE COURSE WITH HMA SURFACING

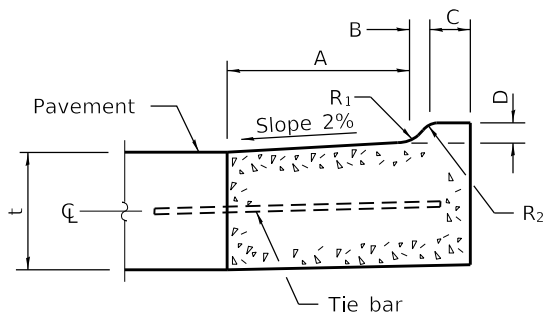

M-2.06 (M-5.15) and M-2.12 (M-5.30)

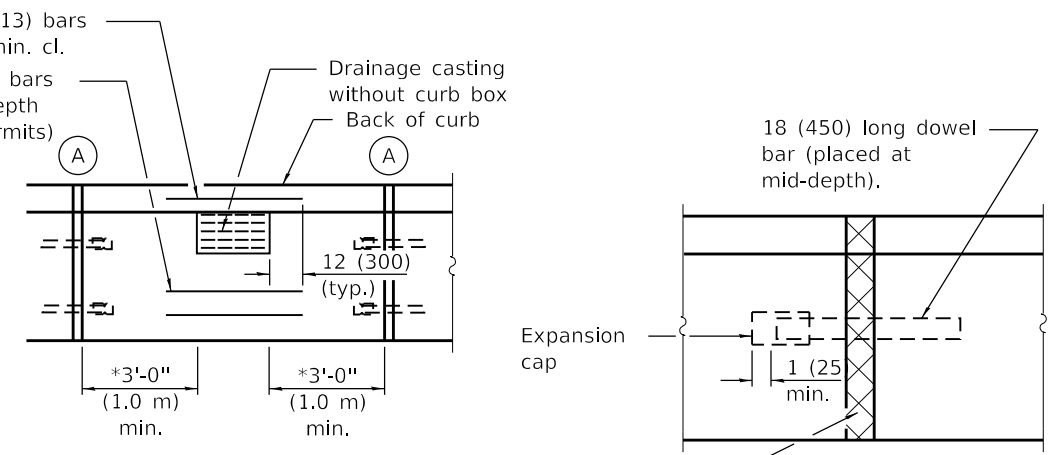

DETAIL A
EXPANSION JOINT

Full depth & width 1 (25) - thick (min.) preformed expansion joint filler.

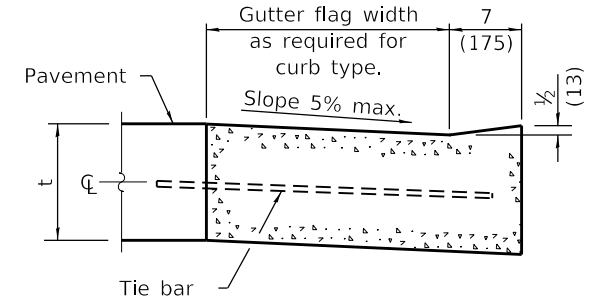

DEPRESSED CURB ADJACENT TO CURB RAMP ACCESSIBLE TO THE DISABLED

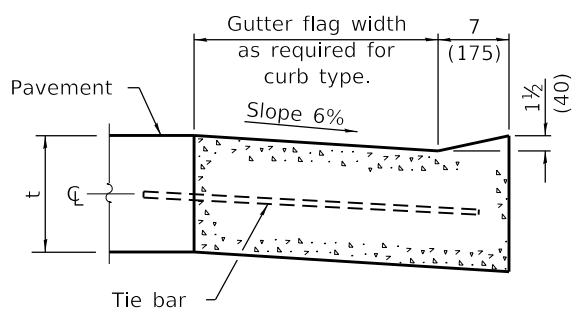

DEPRESSED CURB (TYPICAL)

GENERAL NOTES

The bottom slope of combination curb and gutter constructed adjacent to pcc pavement shall be the same slope as the subbase or 6% when subbase is omitted.

t = Thickness of pavement.

Longitudinal joint tie bars shall be No. 6 (No. 19) at 36 (900) centers in accordance with details for longitudinal construction joint shown on Standard 420001.

A minimum clearance of 2 (50) between the end of the tie bar and the back of the curb shall be maintained.

The dowel bars shown in contraction joints will only be required for monolithic construction.

See Standard 606301 for details of corner islands.

All dimensions are in inches (millimeters) unless otherwise shown.

DATE	REVISIONS
1-1-22	Revised contraction joint spacing adjacent to pcc pavement.
1-1-18	Revised General Note for tie bar spacing to 36 (900) cts.

CONCRETE CURB TYPE B AND COMBINATION CONCRETE CURB AND GUTTER
(Sheet 1 of 2)

STANDARD 606001-08

Illinois Department of Transportation

PASSED January 1, 2022

Michael Brand
ENGINEER OF POLICY AND PROCEDURES

APPROVED January 1, 2022

ENGINEER OF DESIGN AND ENVIRONMENT

ISSUED 1-1-97

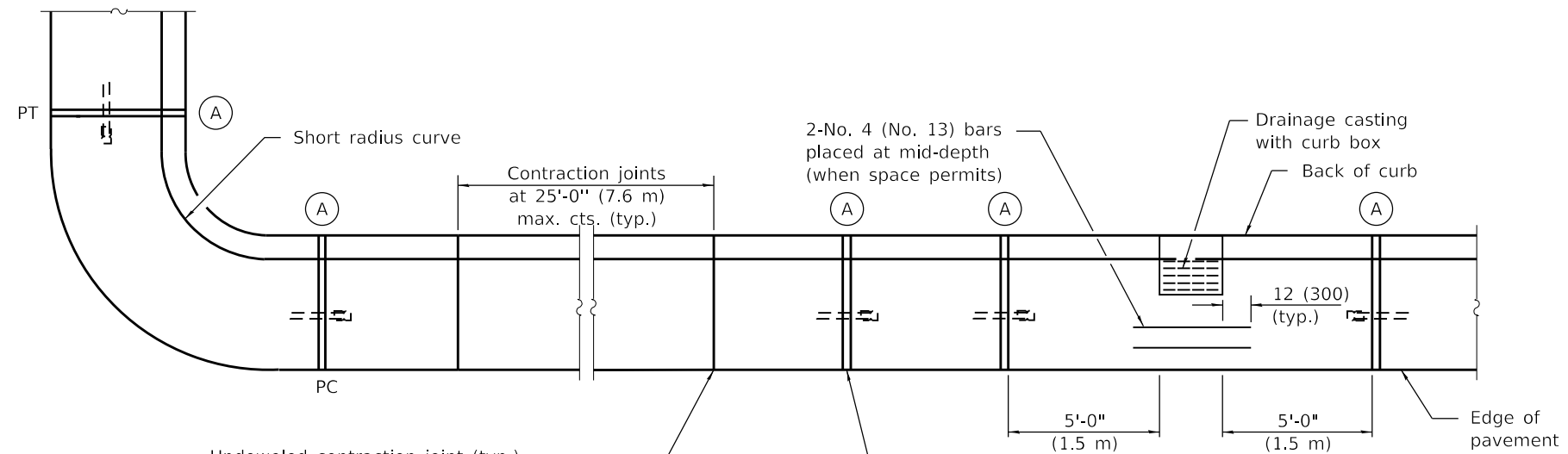

Undoweled contraction joint (typ.) construction options:

1. Form with 1/8 (3) thick steel template 2 (50) deep, and seal.
2. Saw 2 (50) deep at 4 to 24 hours, and seal.
3. Insert 3/4 (20) thick preformed joint filler full depth and width.

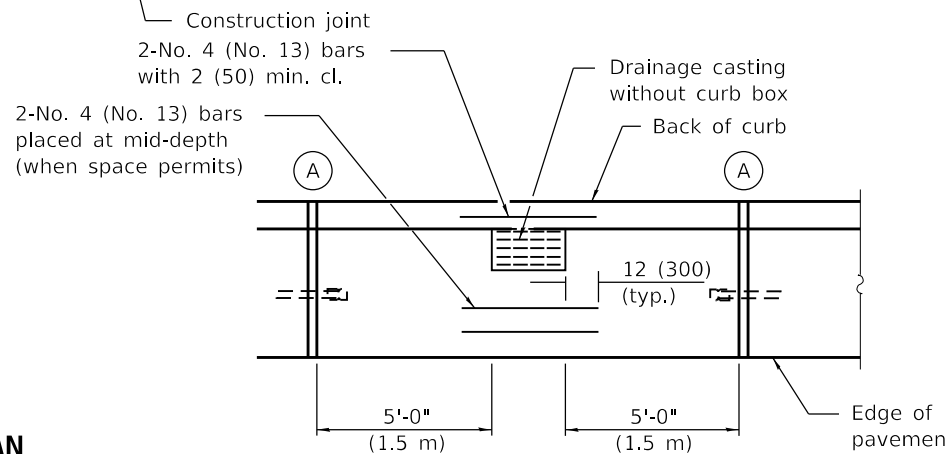

PLAN

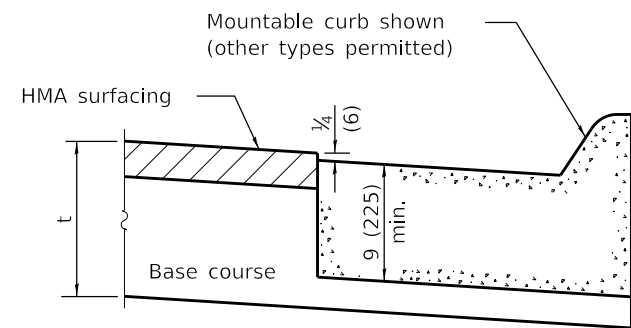

ON DISTURBED SUBGRADE

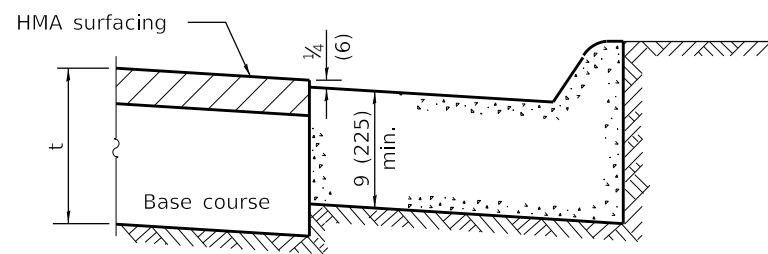

ON UNDISTURBED SUBGRADE

ADJACENT TO FLEXIBLE PAVEMENT

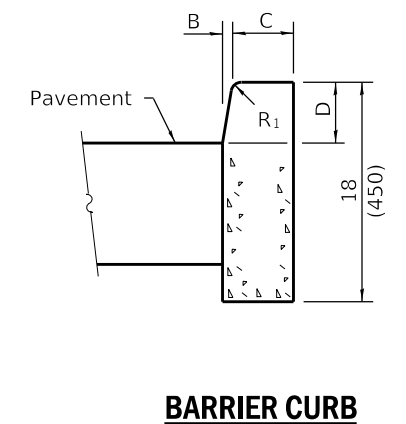
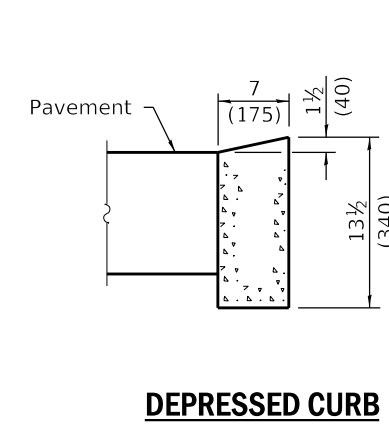

ADJACENT TO FLEXIBLE PAVEMENT

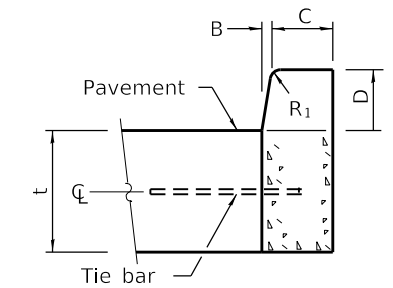
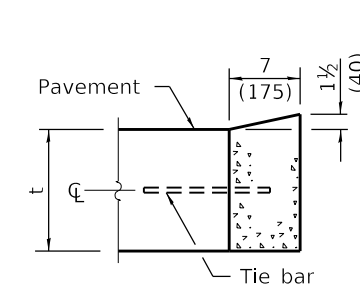

DEPRESSED CURB

BARRIER CURB

ADJACENT TO PCC PAVEMENT OR PCC BASE COURSE

CONCRETE CURB TYPE B

CONCRETE CURB TYPE B AND COMBINATION CONCRETE CURB AND GUTTER

(Sheet 2 of 2)

STANDARD 606001-08

Illinois Department of Transportation

PASSED January 1, 2022
Michael Beard
 ENGINEER OF POLICY AND PROCEDURES

APPROVED January 1, 2022
John C. ...
 ENGINEER OF DESIGN AND ENVIRONMENT

ISSUED 1-1-97