



PROPOSAL SUBMITTED BY		
Superior Road Striping, Inc.		
Contractor's Name		
1980 N. Hawthorne Avenue		
Street		P.O. Box
Melrose Park	IL	60160
City	State	Zip Code

STATE OF ILLINOIS

COUNTY Cook/Lake
Village of Buffalo Grove
 (Name of City, Village, Town or Road District)

FOR THE IMPROVEMENT OF

STREET NAME OR ROUTE Various
 SECTION NO. 19-00000-00-GM
 TYPES OF FUNDS MFT

SPECIFICATIONS (required)

PLANS (required)

CONTRACT BOND (when required)

For Municipal Projects
 Submitted/Approved/Passed

 Mayor President of Board of Trustees Municipal Official
 Date 3/18/19

Department of Transportation
 Concurrence in approval of award

 Regional Engineer

 Date

For County and Road District Projects
 Submitted/Approved

 Highway Commissioner

 Date
 Submitted/Approved

 County Engineer/Superintendent of Highways

 Date

County Cook/Lake
Local Public Agency V. of Buffalo Grove
Section Number 19-00000-00-GM
Route Various

1. THIS AGREEMENT, made and concluded the 18th day of March, 2019,
Month and Year

between the Village of Buffalo Grove
acting by and through its President and Board of Trustees known as the party of the first part, and
Superior Road Striping, Inc. his/their executors, administrators, successors or assigns,
known as the party of the second part.

2. Witnesseth: That for and in consideration of the payments and agreements mentioned in the Proposal hereto attached, to be made and performed by the party of the first part, and according to the terms expressed in the Bond referring to these presents, the party of the second part agrees with said party of the first part at his/their own proper cost and expense to do all the work, furnish all materials and all labor necessary to complete the work in accordance with the plans and specifications hereinafter described, and in full compliance with all of the terms of this agreement and the requirements of the Engineer under it.

3. And it is also understood and agreed that the LPA Formal Contract Proposal, Special Provisions, Affidavit of Illinois Business Office, Apprenticeship or Training Program Certification, and Contract Bond hereto attached, and the Plans for Section 19-00000-00-GM, in the Village of Buffalo Grove, approved by the Illinois Department of Transportation on _____ Date, are essential documents of this contract and are a part hereof.

4. IN WITNESS WHEREOF, The said parties have executed these presents on the date above mentioned.

Attest:
Jane M. Sullivan Clerk
(Seal)

The Village of Buffalo Grove
By Bonnie Sussman
Party of the First Part
(If a Corporation)

Corporate Name Superior Road Striping Inc.
By John Hain
President Party of the Second Part
(If a Co-Partnership)

Attest:
John Hain
Secretary

Partners doing Business under the firm name of

Party of the Second Part
(If an individual)

Party of the Second Part

IN TESTIMONY WHEREOF, the said PRINCIPAL and the said SURETY have caused this instrument to be signed by their respective officers this 18th day of March A.D. 2019

PRINCIPAL

Superior Road Striping, Inc.
(Company Name)

(Company Name)

By: [Signature]
Joan Yario (Signature & Title) President

By: _____
(Signature & Title)

Attest: _____
Joseph Yario (Signature & Title) Vice President

Attest: _____
(Signature & Title)

(If PRINCIPAL is a joint venture of two or more contractors, the company names and authorized signature of each contractor must be affixed.)

STATE OF Illinois
COUNTY OF DuPage

I, Sandra DeHoyos, a Notary Public in and for said county, do hereby certify that

Joan Yario
Joseph Yario

(Insert names of individuals signing on behalf or PRINCIPAL)

who are each personally known to me to be the same persons whose names are subscribed to the foregoing instrument on behalf of PRINCIPAL, appeared before me this day in person and acknowledged respectively, that they signed and delivered said instrument as their free and voluntary act for the uses and purposes therein set forth.

Given under my hand and notarial seal this 18th day of March A.D. 2019

My commission expires February 23, 2020

[Signature]
Sandra DeHoyos Notary Public

(SEAL)

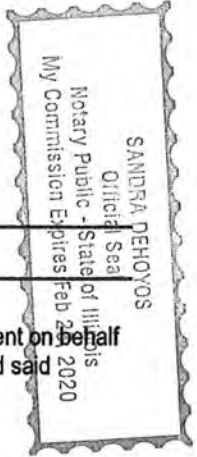

SURETY

The Guarantee Company of North America USA
(Name of Surety)

By: [Signature]
Sharon A. Foulk (Signature of Attorney-in-Fact)

STATE OF Illinois
COUNTY OF Cook

I, Karen E. Socha, a Notary Public in and for said county, do hereby certify that

Sharon A. Foulk

(Insert names of individuals signing on behalf or SURETY)

who are each personally known to me to be the same persons whose names are subscribed to the foregoing instrument on behalf of SURETY, appeared before me this day in person and acknowledged respectively, that they signed and delivered said instrument as their free and voluntary act for the uses and purposes therein set forth.

Given under my hand and notarial seal this 18th day of March A.D. 2019

My commission expires January 13, 2020

[Signature]
Karen E. Socha Notary Public

(SEAL)



Approved this 18th day of MARCH, A.D. 2019

Attest: [Signature]

Village Clerk

[Signature] (Awarding Authority)
[Signature] (Chairman/Mayor/President)



The Guarantee Company of North America USA
Southfield, Michigan

Bond No. 40150024
Principal: Superior Road Striping, Inc.
Obligee: Village of Buffalo Grove

POWER OF ATTORNEY

NOW ALL BY THESE PRESENTS: That THE GUARANTEE COMPANY OF NORTH AMERICA USA, a corporation organized and existing under the laws of the State of Michigan, having its principal office in Southfield, Michigan, does hereby constitute and appoint

Sharon A. Foulk
Arthur J Gallagher Risk Management Services, Inc.

its true and lawful attorney(s)-in-fact to execute, seal and deliver for and on its behalf as surety, any and all bonds and undertakings, contracts of indemnity and other writings obligatory in the nature thereof, which are or may be allowed, required or permitted by law, statute, rule, regulation, contract or otherwise.

The execution of such instrument(s) in pursuance of these presents, shall be as binding upon THE GUARANTEE COMPANY OF NORTH AMERICA USA as fully and amply, to all intents and purposes, as if the same had been duly executed and acknowledged by its regularly elected officers at the principal office.

The Power of Attorney is executed and may be certified so, and may be revoked, pursuant to and by authority of Article IX, Section 9.03 of the By-Laws adopted by the Board of Directors of THE GUARANTEE COMPANY OF NORTH AMERICA USA at a meeting held on the 31st day of December, 2003. The President, or any Vice President, acting with any Secretary or Assistant Secretary, shall have power and authority:

1. To appoint Attorney(s)-in-fact, and to authorize them to execute on behalf of the Company, and attach the Seal of the Company thereto, bonds and undertakings, contracts of indemnity and other writings obligatory in the nature thereof; and
2. To revoke, at any time, any such Attorney-in-fact and revoke the authority given, except as provided below
3. In connection with obligations in favor of the Florida Department of Transportation only, it is agreed that the power and authority hereby given to the Attorney-in-Fact includes any and all consents for the release of retained percentages and/or final estimates on engineering and construction contracts required by the State of Florida Department of Transportation. It is fully understood that consenting to the State of Florida Department of Transportation making payment of the final estimate to the Contractor and/or its assignee, shall not relieve this surety company of any of its obligations under its bond.
4. In connection with obligations in favor of the Kentucky Department of Highways only, it is agreed that the power and authority hereby given to the Attorney-in-Fact cannot be modified or revoked unless prior written personal notice of such intent has been given to the Commissioner – Department of Highways of the Commonwealth of Kentucky at least thirty (30) days prior to the modification or revocation.

Further, this Power of Attorney is signed and sealed by facsimile pursuant to resolution of the Board of Directors of the Company adopted at a meeting duly called and held on the 6th day of December 2011, of which the following is a true excerpt:

RESOLVED that the signature of any authorized officer and the seal of the Company may be affixed by facsimile to any Power of Attorney or certification thereof authorizing the execution and delivery of any bond, undertaking, contracts of indemnity and other writings obligatory in the nature thereof, and such signature and seal when so used shall have the same force and effect as though manually affixed.

IN WITNESS WHEREOF, THE GUARANTEE COMPANY OF NORTH AMERICA USA has caused this instrument to be signed and its corporate seal to be affixed by its authorized officer, this 2nd day of October, 2015.



THE GUARANTEE COMPANY OF NORTH AMERICA USA

Stephen C. Ruschak

Randall Musselman

STATE OF MICHIGAN
County of Oakland

Stephen C. Ruschak, President & Chief Operating Officer

Randall Musselman, Secretary

On this 2nd day of October, 2015 before me came the individuals who executed the preceding instrument, to me personally known, and being by me duly sworn, said that each is the herein described and authorized officer of The Guarantee Company of North America USA; that the seal affixed to said instrument is the Corporate Seal of said Company; that the Corporate Seal and each signature were duly affixed by order of the Board of Directors of said Company.



Cynthia A. Takai
Notary Public, State of Michigan
County of Oakland
My Commission Expires February 27, 2024
Acting in Oakland County

IN WITNESS WHEREOF, I have hereunto set my hand at The Guarantee Company of North America USA offices the day and year above written.

Cynthia A. Takai

I, Randall Musselman, Secretary of THE GUARANTEE COMPANY OF NORTH AMERICA USA, do hereby certify that the above and foregoing is a true and correct copy of a Power of Attorney executed by THE GUARANTEE COMPANY OF NORTH AMERICA USA, which is still in full force and effect.



IN WITNESS WHEREOF, I have thereunto set my hand and attached the seal of said Company this 18th day of March, 2019.

Randall Musselman

Randall Musselman, Secretary



Illinois Department of Transportation

**Local Public Agency
Formal Contract Proposal**

PROPOSAL SUBMITTED BY		
Superior Road Striping Inc.		
Contractor's Name		
1980 N. Hawthorne Ave		
Street		
Melrose Park IL 60160		P.O. Box
City	State	Zip Code

STATE OF ILLINOIS

COUNTY OF Cook/Lake
 Village of Buffalo Grove
 (Name of City, Village, Town or Road District)

FOR THE IMPROVEMENT OF
 STREET NAME OR ROUTE NO. Various
 SECTION NO. 19-00000-00-GM
 TYPES OF FUNDS MFT

- SPECIFICATIONS (required) PLANS (required)

For Municipal Projects
 Submitted/Approved/Passed

Mayor President of Board of Trustees Municipal Official

Date

Department of Transportation

Released for bid based on limited review

Regional Engineer

Date

For County and Road District Projects
 Submitted/Approved

Highway Commissioner

Date

Submitted/Approved

County Engineer/Superintendent of Highways

Date

Note: All proposal documents, including Proposal Guaranty Checks or Proposal Bid Bonds, should be stapled together to prevent loss when bids are processed.

NOTICE TO BIDDERS

County Cook/Lake
 Local Public Agency V. of Buffalo Grove
 Section Number 19-00000-00-GM
 Route Various

Sealed proposals for the improvement described below will be received at the office of Village of Buffalo Grove,
Attn: Village Clerk, 50 Raupp Boulevard, Buffalo Grove, Illinois 60089 until 9:00 AM on February 28, 2019
 Address Time Date

Sealed proposals will be opened and read publicly at the office of Village of Buffalo Grove
Council Chambers, 50 Raupp Boulevard, Buffalo Grove, Illinois 60089 at 9:00 AM on February 28, 2019
 Address Time Date

DESCRIPTION OF WORK

Name 2019 Pavement Markings Project Length: 0.00 feet (0.00 miles)
 Location Various Street Segments and Public Parking Within the Village Limits
 Proposed Improvement Thermoplastic Pavement Marking Removal and Replacement.

1. Plans and proposal forms will be available in the office of Gewalt Hamilton Associates, Inc.
http://www.gha-engineers.com/bidding-info (Download Fee: \$20)
 Address
2. Prequalification
 If checked, the 2 low bidders must file within 24 hours after the letting an "Affidavit of Availability" (Form BC 57), in duplicate, showing all uncompleted contracts awarded to them and all low bids pending award for Federal, State, County, Municipal and private work. ~~One original shall be filed with the Awarding Authority and one original with the IDOT District Office.~~
3. The Awarding Authority reserves the right to waive technicalities and to reject any or all proposals as provided in BLRS Special Provision for Bidding Requirements and Conditions for Contract Proposals.
4. The following BLR Forms shall be returned by the bidder to the Awarding Authority:
 - a. BLR 12200: Local Public Agency Formal Contract Proposal
 - b. BLR 12200a Schedule of Prices
 - c. BLR 12230: Proposal Bid Bond (if applicable)
 - d. BLR 12325: Apprenticeship or Training Program Certification (**do not use for federally funded projects**)
 - e. BLR 12326: Affidavit of Illinois Business Office
5. The quantities appearing in the bid schedule are approximate and are prepared for the comparison of bids. Payment to the Contractor will be made only for the actual quantities of work performed and accepted or materials furnished according to the contract. The scheduled quantities of work to be done and materials to be furnished may be increased, decreased or omitted as hereinafter provided.
6. Submission of a bid shall be conclusive assurance and warranty the bidder has examined the plans and understands all requirements for the performance of work. The bidder will be responsible for all errors in the proposal resulting from failure or neglect to conduct an in depth examination. The Awarding Authority will, in no case be responsible for any costs, expenses, losses or changes in anticipated profits resulting from such failure or neglect of the bidder.
7. The bidder shall take no advantage of any error or omission in the proposal and advertised contract.
8. If a special envelope is supplied by the Awarding Authority, each proposal should be submitted in that envelope furnished by the Awarding Agency and the blank spaces on the envelope shall be filled in correctly to clearly indicate its contents. When an envelope other than the special one furnished by the Awarding Authority is used, it shall be marked to clearly indicate its contents. When sent by mail, the sealed proposal shall be addressed to the Awarding Authority at the address and in care of the official in whose office the bids are to be received. All proposals shall be filed prior to the time and at the place specified in the Notice to Bidders. Proposals received after the time specified will be returned to the bidder unopened.
9. Permission will be given to a bidder to withdraw a proposal if the bidder makes the request in writing or in person before the time for opening proposals.

10. All bidders are prohibited from making any contact with the Village President, Trustees, or any other official or employee of the Village (collectively, 'Municipal Personnel') with regard to the Project, other than in the manner and to the person(s) designated herein. The Buffalo Grove Village Manager reserves the right to disqualify any bidder that is found to have contacted Municipal Personnel in any manner with regard to the Project. Additionally, if the Buffalo Grove Village Manager determines that the contact with Municipal Personnel was in violation of any provision of 720 ILCS 5/33E, the matter will be turned over to the State's Attorney for review and prosecution.
11. All prime contractors shall be IDOT prequalified contractors with a value equal to or greater for the type of work they are to perform as part of the Contract. Furthermore, all bidders are required to register with the Village of Buffalo Grove at:

<https://vrapp.vendorregistry.com/Vendor/Register/Index/buffalo-grove-village-of-il-vendor-registration>

OR

www.vbg.org/bids

All communication during the bid process shall be directed to:

Gewalt Hamilton Associates, Inc.
Attn: Brian Wesolowski, PE
625 Forest Edge Drive
Vernon Hills, Illinois 60061
(847) 821-6235
bwesolowski@gha-engineers.com

PROPOSAL

County Cook/Lake
 Local Public Agency V. of Buffalo Grove
 Section Number 19-00000-00-GM
 Route Various

1. Proposal of Superior Road Striping Inc
 for the improvement of the above section by the construction of Thermoplastic Pavement Marking Removal and Replacement
 for

a total distance of 0.00 feet, of which a distance of 0.00 feet, (0.000 miles) are to be improved.

- 2. The plans for the proposed work are those prepared by Gewalt Hamilton Associates, Inc.
 and approved by the Department of Transportation on _____
- 3. The specifications referred to herein are those prepared by the Department of Transportation and designated as "Standard Specifications for Road and Bridge Construction" and the "Supplemental Specifications and Recurring Special Provisions" thereto, adopted and in effect on the date of invitation for bids.
- 4. The undersigned agrees to accept, as part of the contract, the applicable Special Provisions indicated on the "Check Sheet for Recurring Special Provisions" contained in this proposal.
- 5. The undersigned agrees to complete the work within _____ working days or by 07/03/2019 unless additional time is granted in accordance with the specifications.
- 6. A proposal guaranty in the proper amount, as specified in BLRS Special Provision for Bidding Requirements and Conditions for Contract Proposals, will be required. Bid Bonds will be allowed as a proposal guaranty. Accompanying this proposal is either a bid bond if allowed, on Department form BLR 12230 or a proposal guaranty check, complying with the specifications, made payable to:

Village _____ Treasurer of Buffalo Grove

The amount of the check is Bid Bond (5% of Total Bid) (_____).

- 7. In the event that one proposal guaranty check is intended to cover two or more proposals, the amount must be equal to the sum of the proposal guaranties, which would be required for each individual proposal. If the proposal guaranty check is placed in another proposal, it will be found in the proposal for: Section Number _____
- 8. The successful bidder at the time of execution of the contract will be required to deposit a contract bond for the full amount of the award. When a contract bond is not required, the proposal guaranty check will be held in lieu thereof. If this proposal is accepted and the undersigned fails to execute a contract and contract bond as required, it is hereby agreed that the Bid Bond or check shall be forfeited to the Awarding Authority.
- 9. Each pay item should have a unit price and a total price. If no total price is shown or if there is a discrepancy between the product of the unit price multiplied by the quantity, the unit price shall govern. If a unit price is omitted, the total price will be divided by the quantity in order to establish a unit price.
- 10. A bid will be declared unacceptable if neither a unit price nor a total price is shown.
- 11. The undersigned submits herewith the schedule of prices on BLR 12200a covering the work to be performed under this contract.
- 12. The undersigned further agrees that if awarded the contract for the sections contained in the combinations on BLR 12200a, the work shall be in accordance with the requirements of each individual proposal for the multiple bid specified in the Schedule for Multiple Bids below.



SCHEDULE OF PRICES

County Cook/Lake
 Local Public Agency V. of Buffalo Grove
 Section 19-00000-00-GM
 Route Various

Schedule for Single Bid

(For complete information covering these items, see plans and specifications)

Bidder's Proposal for making Entire Improvements

Item No.	Items	Unit	Quantity	Unit Price	Total
78000100	Thermoplastic Pavement Marking - Letters and Symbols	SF	565.0	4.00	2260.00
78000200	Thermoplastic Pavement Marking - Line 4"	FT	33,195.0	.55	18257.25
78000400	Thermoplastic Pavement Marking - Line 6"	FT	2,175.0	.75	1631.25
78000600	Thermoplastic Pavement Marking - Line 12"	FT	1,680.0	1.50	2520.00
78000650	Thermoplastic Pavement Marking - Line 24"	FT	325.0	4.00	1300.00
X0327979	Pavement Marking Removal	SF	14,745.0	.55	8109.75
X7010216	Traffic Control and Protection, (Special)	LS	1.0	4000.00	4000.00

Total Bid: 38,078.25

CONTRACTOR CERTIFICATIONS

County Cook/Lake
 Local Public Agency V. of Buffalo Grove
 Section Number 19-00000-00-GM
 Route Various

The certifications hereinafter made by the bidder are each a material representation of fact upon which reliance is placed should the Department enter into the contract with the bidder.

1. **Debt Delinquency.** The bidder or contractor or subcontractor, respectively, certifies that it is not delinquent in the payment of any tax administered by the Department of Revenue unless the individual or other entity is contesting, in accordance with the procedures established by the appropriate revenue Act, its liability for the tax or the amount of tax. Making a false statement voids the contract and allows the Department to recover all amounts paid to the individual or entity under the contract in a civil action.
2. **Bid-Rigging or Bid Rotating.** The bidder or contractor or subcontractor, respectively, certifies that it is not barred from contracting with the Department by reason of a violation of either 720 ILCS 5/33E-3 or 720 ILCS 5/33E-4.

A violation of Section 33E-3 would be represented by a conviction of the crime of bid-rigging which, in addition to Class 3 felony sentencing, provides that any person convicted of this offense or any similar offense of any state or the United States which contains the same elements as this offense shall be barred for 5 years from the date of conviction from contracting with any unit of State or local government. No corporation shall be barred from contracting with any unit of State or local government as a result of a conviction under this Section of any employee or agent of such corporation if the employee so convicted is no longer employed by the corporation and: (1) it has been finally adjudicated not guilty or (2) if it demonstrates to the governmental entity with which it seeks to contract and that entity finds that the commission of the offense was neither authorized, requested, commanded, nor performed by a director, officer or a high managerial agent in behalf of the corporation.

A violation of Section 33E-4 would be represented by a conviction of the crime of bid-rotating which, in addition to Class 2 felony sentencing, provides that any person convicted of this offense or any similar offense of any state or the United States which contains the same elements as this offense shall be permanently barred from contracting with any unit of State or local government. No corporation shall be barred from contracting with any unit of State or local government as a result of a conviction under this Section of any employee or agent of such corporation if the employee so convicted is no longer employed by the corporation and: (1) it has been finally adjudicated not guilty or (2) if it demonstrates to the governmental entity with which it seeks to contract and that entity finds that the commission of the offense was neither authorized, requested, commanded, nor performed by a director, officer or a high managerial agent in behalf of the corporation.

3. **Bribery.** The bidder or contractor or subcontractor, respectively, certifies that it has not been convicted of bribery or attempting to bribe an officer or employee of the State of Illinois or any unit of local government, nor has the firm made an admission of guilt of such conduct which is a matter of record, nor has an official, agent, or employee of the firm committed bribery or attempted bribery on behalf of the firm and pursuant to the direction or authorization of a responsible official of the firm.
4. **Interim Suspension or Suspension.** The bidder or contractor or subcontractor, respectively, certifies that it is not currently under a suspension as defined in Subpart I of Title 44 Subtitle A Chapter III Part 6 of the Illinois Administrative Code. Furthermore, if suspended prior to completion of this work, the contract or contracts executed for the completion of this work may be cancelled.

SIGNATURES

County Cook/Lake
 Local Public Agency V. of Buffalo Grove
 Section Number 19-00000-00-GM
 Route Various

(If an individual)

Signature of Bidder _____

Business Address _____

(If a partnership)

Firm Name _____

Signed By _____

Business Address _____

Inset Names and Addressed of All Partners

(If a corporation)

Corporate Name SUPERIOR ROAD STRIPING INC.

Signed By JOAN YARD JOAN YARD
President

Business Address 1980 N. HAWTHORNE AVE
MELROSE PARK IL 60160

Inset Names of Officers

President JOAN YARD

Secretary JOAN YARD

Treasurer JOSEPH YARD

Attest: JOAN YARD
Secretary

Local Agency Proposal Bid Bond



Illinois Department of Transportation

RETURN WITH BID

Route Various
County Cook/Lake
Local Agency V. of Buffalo Grove
Section 19-00000-00-GM

PAPER BID BOND

WE Superior Road Striping, Inc. 1980 Hawthorne Avenue, Melrose Park, IL 60160 as PRINCIPAL, and The Guarantee Company of North America USA One Towne Square, Suite 1470 Southfield, MI 48076 as SURETY,

are held jointly, severally and firmly bound unto the above Local Agency (hereafter referred to as "LA") in the penal sum of 5% of the total bid price, or for the amount specified in the proposal documents in effect on the date of invitation for bids whichever is the lesser sum. We bind ourselves, our heirs, executors, administrators, successors, and assigns, jointly pay to the LA this sum under the conditions of this instrument.

WHEREAS THE CONDITION OF THE FOREGOING OBLIGATION IS SUCH that, the said PRINCIPAL is submitting a written proposal to the LA acting through its awarding authority for the construction of the work designated as the above section.

THEREFORE if the proposal is accepted and a contract awarded to the PRINCIPAL by the LA for the above designated section and the PRINCIPAL shall within fifteen (15) days after award enter into a formal contract, furnish surety guaranteeing the faithful performance of the work, and furnish evidence of the required insurance coverage, all as provided in the "Standard Specifications for Road and Bridge Construction" and applicable Supplemental Specifications, then this obligation shall become void; otherwise it shall remain in full force and effect.

IN THE EVENT the LA determines the PRINCIPAL has failed to enter into a formal contract in compliance with any requirements set forth in the preceding paragraph, then the LA acting through its awarding authority shall immediately be entitled to recover the full penal sum set out above, together with all court costs, all attorney fees, and any other expense of recovery.

IN TESTIMONY WHEREOF, the said PRINCIPAL and the said SURETY have caused this instrument to be signed by their respective officers this 28th day of February, 2019

Principal

Superior Road Striping, Inc. (Company Name)

By: Joan Yario, President (Signature and Title)

(Company Name)

By: (Signature and Title)

(If PRINCIPLE is a joint venture of two or more contractors, the company names, and authorized signatures of each contractor must be affixed)

The Guarantee Company of North America USA (Name of Surety)

Surety By: Sharon A. Foulk (Signature and Title)



STATE OF Illinois
COUNTY OF Cook

I, See Attached, a Notary Public in and for said county, do hereby certify that Joan Yario and Sharon A. Foulk

(Insert names of individuals signing on behalf of PRINCIPAL & SURETY)

who are each personally known to me to be the same persons whose names are subscribed to the foregoing instrument on behalf of PRINCIPAL and SURETY, appeared before me this day in person and acknowledged respectively, that they signed and delivered said instruments as their free and voluntary act for the uses and purposes therein set forth.

Given under my hand and notarial seal this 28th day of February, 2019

My commission expires January 7, 2020

See Attached (Notary Public)

ELECTRONIC BID

Electronic bid bond is allowed (box must be checked by LA if electronic bid bond is allowed) The Principal may submit an electronic bid bond, in lieu of completing the above section of the Proposal Bid Bond Form. By providing an electronic bid bond ID code and signing below, the Principal is ensuring the identified electronic bid bond has been executed and the Principal and Surety are firmly bound unto the LA under the conditions of the bid bond as shown above. (If PRINCIPAL is a joint venture of two or more contractors, an electronic bid bond ID code, company/Bidder name title and date must be affixed for each contractor in the venture.)

Electronic Bid Bond ID Code

(Company/Bidder Name)

(Signature and Title)

Date

SURETY COMPANY ACKNOWLEDGMENT

STATE OF ILLINOIS)
COUNTY OF COOK) ss:

On this **28th** day of **February** in the year **2019**, before me personally came **Sharon A. Foulk**, to me known, who, being by me duly sworn, did depose and say that she resides in **Island Lake, Illinois**; that he is the **ATTORNEY-IN-FACT** of **The Guarantee Company of North America USA**, the corporation described in and which executed the above instrument; that she knows the seal of said corporation; that the seal affixed to said instrument is such corporate seal; that it was so affixed by order of the board of directors of said corporation, and that he signed his name thereto by like order.



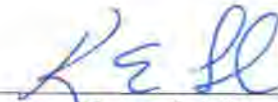

Notary Public
Karen E. Socha, Exp. 1/13/2020

STATE OF ILLINOIS)
COUNTY OF DUPAGE) ss:

On this **9th** day of **February** in the year **2019** before me personally came **Joan Yario**, to me known, who, being by me duly sworn, did depose and say he/she resides in **Bensenville, Illinois** and that she is the **President** of the **Superior Road Striping, Inc.** the corporation described in and which executed the foregoing instrument; that he/she knows the seal of said corporation; that the seal affixed to said instrument is such corporate seal; that it was so affixed by order of the board of said corporation and that he signed his/her name thereto by like order.

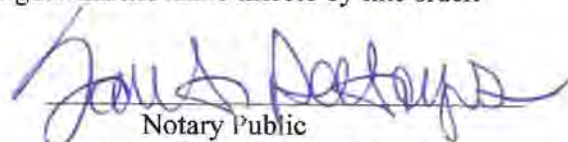

Notary Public
Sandra De Hoyos, Exp. 2/23/2020





The Guarantee Company of North America USA
Southfield, Michigan

Bond No. Bid Bond
Principal: Superior Road Striping, Inc.
Obligee: Village of Buffalo Grove

POWER OF ATTORNEY

NOW ALL BY THESE PRESENTS: That **THE GUARANTEE COMPANY OF NORTH AMERICA USA**, a corporation organized and existing under the laws of the State of Michigan, having its principal office in Southfield, Michigan, does hereby constitute and appoint

Sharon A. Foulk
Arthur J Gallagher Risk Management Services, Inc.

its true and lawful attorney(s)-in-fact to execute, seal and deliver for and on its behalf as surety, any and all bonds and undertakings, contracts of indemnity and other writings obligatory in the nature thereof, which are or may be allowed, required or permitted by law, statute, rule, regulation, contract or otherwise.

The execution of such instrument(s) in pursuance of these presents, shall be as binding upon **THE GUARANTEE COMPANY OF NORTH AMERICA USA** as fully and amply, to all intents and purposes, as if the same had been duly executed and acknowledged by its regularly elected officers at the principal office.

The Power of Attorney is executed and may be certified so, and may be revoked, pursuant to and by authority of Article IX, Section 9.03 of the By-Laws adopted by the Board of Directors of **THE GUARANTEE COMPANY OF NORTH AMERICA USA** at a meeting held on the 31st day of December, 2003. The President, or any Vice President, acting with any Secretary or Assistant Secretary, shall have power and authority:

1. To appoint Attorney(s)-in-fact, and to authorize them to execute on behalf of the Company, and attach the Seal of the Company thereto, bonds and undertakings, contracts of indemnity and other writings obligatory in the nature thereof; and
2. To revoke, at any time, any such Attorney-in-fact and revoke the authority given, except as provided below
3. In connection with obligations in favor of the Florida Department of Transportation only, it is agreed that the power and authority hereby given to the Attorney-in-Fact includes any and all consents for the release of retained percentages and/or final estimates on engineering and construction contracts required by the State of Florida Department of Transportation. It is fully understood that consenting to the State of Florida Department of Transportation making payment of the final estimate to the Contractor and/or its assignee, shall not relieve this surety company of any of its obligations under its bond.
4. In connection with obligations in favor of the Kentucky Department of Highways only, it is agreed that the power and authority hereby given to the Attorney-in-Fact cannot be modified or revoked unless prior written personal notice of such intent has been given to the Commissioner – Department of Highways of the Commonwealth of Kentucky at least thirty (30) days prior to the modification or revocation.

Further, this Power of Attorney is signed and sealed by facsimile pursuant to resolution of the Board of Directors of the Company adopted at a meeting duly called and held on the 6th day of December 2011, of which the following is a true excerpt:

RESOLVED that the signature of any authorized officer and the seal of the Company may be affixed by facsimile to any Power of Attorney or certification thereof authorizing the execution and delivery of any bond, undertaking, contracts of indemnity and other writings obligatory in the nature thereof, and such signature and seal when so used shall have the same force and effect as though manually affixed.

IN WITNESS WHEREOF, **THE GUARANTEE COMPANY OF NORTH AMERICA USA** has caused this instrument to be signed and its corporate seal to be affixed by its authorized officer, this 2nd day of October, 2015.



THE GUARANTEE COMPANY OF NORTH AMERICA USA

Stephen C. Ruschak

Randall Musselman

STATE OF MICHIGAN
County of Oakland

Stephen C. Ruschak, President & Chief Operating Officer

Randall Musselman, Secretary

On this 2nd day of October, 2015 before me came the individuals who executed the preceding instrument, to me personally known, and being by me duly sworn, said that each is the herein described and authorized officer of The Guarantee Company of North America USA; that the seal affixed to said instrument is the Corporate Seal of said Company; that the Corporate Seal and each signature were duly affixed by order of the Board of Directors of said Company.



Cynthia A. Takai
Notary Public, State of Michigan
County of Oakland

My Commission Expires February 27, 2024
Acting in Oakland County

IN WITNESS WHEREOF, I have hereunto set my hand at The Guarantee Company of North America USA offices the day and year above written.

Cynthia A. Takai

I, Randall Musselman, Secretary of **THE GUARANTEE COMPANY OF NORTH AMERICA USA**, do hereby certify that the above and foregoing is a true and correct copy of a Power of Attorney executed by **THE GUARANTEE COMPANY OF NORTH AMERICA USA**, which is still in full force and effect.



IN WITNESS WHEREOF, I have thereunto set my hand and attached the seal of said Company this 28th day of February, 2019.

Randall Musselman

Randall Musselman, Secretary



Return with Bid

Route	<u>Various</u>
County	<u>Cook/Lake</u>
Local Agency	<u>V. of Buffalo Grove</u>
Section	<u>19-00000-00-GM</u>

All contractors are required to complete the following certification:

- For this contract proposal or for all groups in this deliver and install proposal.
- For the following deliver and install groups in this material proposal:

Illinois Department of Transportation policy, adopted in accordance with the provisions of the Illinois Highway Code, requires this contract to be awarded to the lowest responsive and responsible bidder. The award decision is subject to approval by the Department. In addition to all other responsibility factors, this contract or deliver and install proposal requires all bidders and all bidders' subcontractors to disclose participation in apprenticeship or training programs that are (1) approved by and registered with the United States Department of Labor's Bureau of Apprenticeship and Training, and (2) applicable to the work of the above indicated proposals or groups. Therefore, all bidders are required to complete the following certification:

- I. Except as provided in paragraph IV below, the undersigned bidder certifies that it is a participant, either as an individual or as part of a group program, in an approved apprenticeship or training program applicable to each type of work or craft that the bidder will perform with its own employees.
- II. The undersigned bidder further certifies for work to be performed by subcontract that each of its subcontractors submitted for approval either (A) is, at the time of such bid, participating in an approved, applicable apprenticeship or training program; or (B) will, prior to commencement of performance of work pursuant to this contract, establish participation in an approved apprenticeship or training program applicable to the work of the subcontract.
- III. The undersigned bidder, by inclusion in the list in the space below, certifies the official name of each program sponsor holding the Certificate of Registration for all of the types of work or crafts in which the bidder is a participant and that will be performed with the bidder's employees. Types of work or craft that will be subcontracted shall be included and listed as subcontract work. The list shall also indicate any type of work or craft job category for which there is no applicable apprenticeship or training program available.

INTERNATIONAL BROTHERHOOD OF TEAMSTERS
Local 786

- IV. Except for any work identified above, any bidder or subcontractor that shall perform all or part of the work of the contract or deliver and install proposal solely by individual owners, partners or members and not by employees to whom the payment of prevailing rates of wages would be required, check the following box, and identify the owner/operator workforce and positions of ownership.

The requirements of this certification and disclosure are a material part of the contract, and the contractor shall require this certification provision to be included in all approved subcontracts. The bidder is responsible for making a complete report and shall make certain that each type of work or craft job category that will be utilized on the project is accounted for and listed. The Department at any time before or after award may require the production of a copy of each applicable Certificate of Registration issued by the United States Department of Labor evidencing such participation by the contractor and any or all of its subcontractors. In order to fulfill the participation requirement, it shall not be necessary that any applicable program sponsor be currently taking or that it will take applications for apprenticeship, training or employment during the performance of the work of this contract or deliver and install proposal.

Bidder: Superior Road Striping
Address: 1930 N. Hawthorne Ave
Melrose Park IL 60160

By:  (Signature)
Title: President



Affidavit of Illinois Business Office

County Cook/Lake
Local Public Agency V. of Buffalo Grove
Section Number 19-00000-00-GM
Route Various

State of IL
County of DUPAGE

I, JOAN YARD of Bensenville, IL
(Name of Affiant) (City of Affiant) (State of Affiant)

being first duly sworn upon oath, states as follows:

- 1. That I am the President of Superior Road Striping Inc.
2. That I have personal knowledge of the facts herein stated.
3. That, if selected under this proposal, Superior Road Striping Inc. will maintain a business office in the State of Illinois which will be located in Cook County, Illinois.
4. That this business office will serve as the primary place of employment for any persons employed in the construction contemplated by this proposal.
5. That this Affidavit is given as a requirement of state law as provided in Section 30-22(8) of the Illinois Procurement Code.

Signature: JO Joan Yard
(Print Name of Affiant): JOAN YARD

This instrument was acknowledged before me on 20 day of FEBRUARY, 2019.



Signature of Notary Public: Sandra DeHoyos



Illinois Department of Transportation

Bureau of Construction
2300 South Dirksen Parkway/Room 322
Springfield, Illinois 62764

Affidavit of Availability For the Letting of 2/28/2019

Instructions: Complete this form by either typing or using black ink. "Authorization to Bid" will not be issued unless both sides of this form are completed in detail. Use additional forms as needed to list all work.

Part I. Work Under Contract

List below all work you have under contract as either a prime contractor or a subcontractor. It is required to include all pending low bids not yet awarded or rejected. In a joint venture, list only that portion of the work which is the responsibility of your company. The uncompleted dollar value is to be based upon the most recent engineer's or owners estimate, and must include work subcontracted to others. If no work is contracted, show **NONE**.

	1	2	3	4	Awards Pending	
Contract Number	60T75					
Contract With	Berger Excavat	Peter Baker	Peter Baker	Curran		
Estimated Completion Date	2019	2019	2019	2019		
Total Contract Price	91,237.00	13,260.00	83,418.00	526,747.00		Accumulated Totals
Uncompleted Dollar Value if Firm is the Prime Contractor						
Uncompleted Dollar Value if Firm is the Subcontractor	91,237.00	13,260.00	83,418.00	261,110.00		\$449,025.00
Total Value of All Work						\$449,025.00

Part II. Awards Pending and Uncompleted Work to be done with your own forces.

List below the uncompleted dollar value of work for each contract and awards pending to be completed with your own forces. All work subcontracted to others will be listed on the reverse of this form. In a joint venture, list only that portion of the work to be done by your company. If no work is contracted, show **NONE**.

						Accumulated Totals
Earthwork						
Portland Cement Concrete Paving						
HMA Plant Mix						
HMA Paving						
Clean & Seal Cracks/Joints						
Aggregate Bases & Surfaces						
Highway, R.R. and Waterway Structures						
Drainage						
Electrical						
Cover and Seal Coats						
Concrete Construction						
Landscaping	Removal					
	Grading	35,322.00		29,541.00	74,855.00	\$139,718.00
Fencing	Urethane			1,012.00		\$1,012.00
Guardrail	Polyurea	24,376.00				\$24,376.00
Painting	Polymer				109,575.00	\$109,575.00
Signing						
Cold Milling, Planning & Rotomilling						
Demolition						
Pavement Markings (Paint)	Therm	25,144.00	13,260.00	49,020.00	4,469.00	\$91,893.00
Other Construction (List)	Rpm	6,395.00		3,845.00	72,211.00	\$82,451.00
						\$ 0.00
Totals		\$91,237.00	\$13,260.00	\$83,418.00	\$261,110.00	\$449,025.00

Disclosure of this information is **REQUIRED** to accomplish the statutory purpose as outlined in the "Illinois Procurement Code." Failure to comply will result in non-issuance of an "Authorization To Bid." This form has been approved by the State Forms Management Center.



Illinois Department of Transportation

Bureau of Construction
2300 South Dirksen Parkway/Room 322
Springfield, Illinois 62764

Affidavit of Availability For the Letting of 2/28/2019

Instructions: Complete this form by either typing or using black ink. "Authorization to Bid" will not be issued unless both sides of this form are completed in detail. Use additional forms as needed to list all work.

Part I. Work Under Contract

List below all work you have under contract as either a prime contractor or a subcontractor. It is required to include all pending low bids not yet awarded or rejected. In a joint venture, list only that portion of the work which is the responsibility of your company. The uncompleted dollar value is to be based upon the most recent engineer's or owners estimate, and must include work subcontracted to others. If no work is contracted, show **NONE**.

	1	2	3	4	Awards Pending	
Contract Number		62D65	62D16	62D64		
Contract With	Geneva Const	JA Johnson	K-Five	K-Five		
Estimated Completion Date	2019	2019	2019	2019		
Total Contract Price	22,378.00	61,719.00	81,915.00	78,162.00		Accumulated Totals
Uncompleted Dollar Value if Firm is the Prime Contractor						
Uncompleted Dollar Value if Firm is the Subcontractor	22,378.00	61,719.00	51,683.00	78,162.00		\$213,942.00
Total Value of All Work						\$213,942.00

Part II. Awards Pending and Uncompleted Work to be done with your own forces.

List below the uncompleted dollar value of work for each contract and awards pending to be completed with your own forces. All work subcontracted to others will be listed on the reverse of this form. In a joint venture, list only that portion of the work to be done by your company. If no work is contracted, show **NONE**.

						Accumulated Totals
Earthwork						
Portland Cement Concrete Paving						
HMA Plant Mix						
HMA Paving						
Clean & Seal Cracks/Joints						
Aggregate Bases & Surfaces						
Highway, R.R. and Waterway Structures						
Drainage						
Electrical						
Cover and Seal Coats						
Concrete Construction						
Landscaping						
Fencing						
Guardrail						
Painting						
Signing						
Cold Milling, Planning & Rotomilling						
Demolition						
Pavement Markings (Paint)	2,530.00	32,799.00	35,383.00	45,601.00		\$116,313.00
Other Construction (List)	7,200.00	28,920.00	16,300.00	32,561.00		\$84,981.00
						\$ 0.00
Totals	\$22,378.00	\$61,719.00	\$51,683.00	\$78,162.00		\$213,942.00

Disclosure of this information is **REQUIRED** to accomplish the statutory purpose as outlined in the "Illinois Procurement Code." Failure to comply will result in non-issuance of an "Authorization To Bid." This form has been approved by the State Forms Management Center.



Illinois Department of Transportation

Bureau of Construction
2300 South Dirksen Parkway/Room 322
Springfield, Illinois 62764

Affidavit of Availability For the Letting of 2/28/2019

Instructions: Complete this form by either typing or using black ink. "Authorization to Bid" will not be issued unless both sides of this form are completed in detail. Use additional forms as needed to list all work.

Part I. Work Under Contract

List below all work you have under contract as either a prime contractor or a subcontractor. It is required to include all pending low bids not yet awarded or rejected. In a joint venture, list only that portion of the work which is the responsibility of your company. The uncompleted dollar value is to be based upon the most recent engineer's or owners estimate, and must include work subcontracted to others. If no work is contracted, show **NONE**.

	1	2	3	4	Awards Pending	
Contract Number	61E80	61E05	60L71	60L72		
Contract With	K-Five	Plote	TSI	TSI		
Estimated Completion Date	2019	2019	2019	2019		
Total Contract Price	6,056.00	43,970.00	144,218.00	93,125.00		Accumulated Totals
Uncompleted Dollar Value if Firm is the Prime Contractor						
Uncompleted Dollar Value if Firm is the Subcontractor	6,056.00	43,970.00	144,218.00	20,736.00		\$214,980.00
Total Value of All Work						\$214,980.00

Part II. Awards Pending and Uncompleted Work to be done with your own forces.

List below the uncompleted dollar value of work for each contract and awards pending to be completed with your own forces. All work subcontracted to others will be listed on the reverse of this form. In a joint venture, list only that portion of the work to be done by your company. If no work is contracted, show **NONE**.

					Accumulated Totals
Earthwork					
Portland Cement Concrete Paving					
HMA Plant Mix					
HMA Paving					
Clean & Seal Cracks/Joints					
Aggregate Bases & Surfaces					
Highway, R.R. and Waterway Structures					
Drainage					
Electrical					
Cover and Seal Coats					
Concrete Construction <i>Removal</i>					
Landscaping <i>Grading</i>					
Fencing <i>UPthane</i>		17,708.00	61,774.00		\$79,482.00
Guardrail <i>Polyurea</i>					
Painting <i>Polymer</i>					
Signing					
Cold Milling, Planning & Rotomilling					
Demolition					
Pavement Markings (Paint) <i>Thermid</i>	6,056.00	17,315.00	36,766.00		\$60,137.00
Other Construction (List) <i>RPM</i>		8,947.00	45,678.00	20,736.00	\$75,361.00
					\$ 0.00
Totals	\$6,056.00	\$43,970.00	\$144,218.00	\$20,736.00	\$214,980.00

Disclosure of this information is **REQUIRED** to accomplish the statutory purpose as outlined in the "Illinois Procurement Code." Failure to comply will result in non-issuance of an "Authorization To Bid." This form has been approved by the State Forms Management Center.



Illinois Department of Transportation

Bureau of Construction
2300 South Dirksen Parkway/Room 322
Springfield, Illinois 62764

Affidavit of Availability For the Letting of 2/28/2019

Instructions: Complete this form by either typing or using black ink. "Authorization to Bid" will not be issued unless both sides of this form are completed in detail. Use additional forms as needed to list all work.

Part I. Work Under Contract

List below all work you have under contract as either a prime contractor or a subcontractor. It is required to include all pending low bids not yet awarded or rejected. In a joint venture, list only that portion of the work which is the responsibility of your company. The uncompleted dollar value is to be based upon the most recent engineer's or owners estimate, and must include work subcontracted to others. If no work is contracted, show **NONE**.

	1	2	3	4	Awards Pending	
Contract Number	46476	46486	46481	46484		
Contract With	Idot	Idot	Idot	Idot		
Estimated Completion Date	2019	2019	2019	2019		
Total Contract Price	762,500.00	649,500.00	278,325.00	357,143.75		Accumulated Totals
Uncompleted Dollar Value if Firm is the Prime Contractor	762,500.00	649,500.00	278,325.00	357,143.75		\$2,047,468.75
Uncompleted Dollar Value if Firm is the Subcontractor						
Total Value of All Work						\$2,047,468.75

Part II. Awards Pending and Uncompleted Work to be done with your own forces.

List below the uncompleted dollar value of work for each contract and awards pending to be completed with your own forces. All work subcontracted to others will be listed on the reverse of this form. In a joint venture, list only that portion of the work to be done by your company. If no work is contracted, show **NONE**.

					Accumulated Totals
Earthwork					
Portland Cement Concrete Paving					
HMA Plant Mix					
HMA Paving					
Clean & Seal Cracks/Joints					
Aggregate Bases & Surfaces					
Highway, R.R. and Waterway Structures					
Drainage					
Electrical					
Cover and Seal Coats					
Concrete Construction		25,000.00			\$25,000.00
Landscaping					
Fencing		349,500.00			\$349,500.00
Guardrail					
Painting					
Signing					
Cold Milling, Planning & Rotomilling					
Demolition					
Pavement Markings (Paint)	762,500.00	275,000.00			\$1,037,500.00
Other Construction (List)			278,325.00	357,143.75	\$635,468.75
					\$ 0.00
Totals	\$762,500.00	\$649,500.00	\$278,325.00	\$357,143.75	\$2,047,468.75

Disclosure of this information is **REQUIRED** to accomplish the statutory purpose as outlined in the "Illinois Procurement Code." Failure to comply will result in non-issuance of an "Authorization To Bid." This form has been approved by the State Forms Management Center.



Illinois Department of Transportation

Bureau of Construction
2300 South Dirksen Parkway/Room 322
Springfield, Illinois 62764

Affidavit of Availability For the Letting of 2/28/2019

Instructions: Complete this form by either typing or using black ink. "Authorization to Bid" will not be issued unless both sides of this form are completed in detail. Use additional forms as needed to list all work.

Part I. Work Under Contract

List below all work you have under contract as either a prime contractor or a subcontractor. It is required to include all pending low bids not yet awarded or rejected. In a joint venture, list only that portion of the work which is the responsibility of your company. The uncompleted dollar value is to be based upon the most recent engineer's or owners estimate, and must include work subcontracted to others. If no work is contracted, show **NONE**.

	1	2	3	4	Awards Pending	
Contract Number	46485	46482	46483			
Contract With	Idot	Idot	Idot			
Estimated Completion Date	2019	2019	2019			
Total Contract Price	371,418.75	1,114,318.75	579,618.75			Accumulated Totals
Uncompleted Dollar Value if Firm is the Prime Contractor	371,418.75	1,114,318.75	579,618.75			\$2,065,356.25
Uncompleted Dollar Value if Firm is the Subcontractor						
Total Value of All Work						\$2,065,356.25

Part II. Awards Pending and Uncompleted Work to be done with your own forces.

List below the uncompleted dollar value of work for each contract and awards pending to be completed with your own forces. All work subcontracted to others will be listed on the reverse of this form. In a joint venture, list only that portion of the work to be done by your company. If no work is contracted, show **NONE**.

					Accumulated Totals
Earthwork					
Portland Cement Concrete Paving					
HMA Plant Mix					
HMA Paving					
Clean & Seal Cracks/Joints					
Aggregate Bases & Surfaces					
Highway, R.R. and Waterway Structures					
Drainage					
Electrical					
Cover and Seal Coats					
Concrete Construction <i>Removal</i>					
Landscaping <i>Grass</i>					
Fencing <i>Urethane</i>					
Guardrail <i>Polyurea</i>					
Painting <i>Polymer</i>					
Signing					
Cold Milling, Planning & Rotomilling					
Demolition					
Pavement Markings (Paint) <i>Therm</i>					
Other Construction (List) <i>RPM</i>	371,418.75	1,114,318.75	579,618.75		\$2,065,356.25
					\$ 0.00
Totals	\$371,418.75	\$1,114,318.75	\$579,618.75		\$2,065,356.25

Disclosure of this information is **REQUIRED** to accomplish the statutory purpose as outlined in the "Illinois Procurement Code." Failure to comply will result in non-issuance of an "Authorization To Bid." This form has been approved by the State Forms Management Center.



Illinois Department of Transportation

Bureau of Construction
2300 South Dirksen Parkway/Room 322
Springfield, Illinois 62764

Affidavit of Availability For the Letting of _____

Instructions: Complete this form by either typing or using black ink. "Authorization to Bid" will not be issued unless both sides of this form are completed in detail. Use additional forms as needed to list all work.

Part I. Work Under Contract

List below all work you have under contract as either a prime contractor or a subcontractor. It is required to include all pending low bids not yet awarded or rejected. In a joint venture, list only that portion of the work which is the responsibility of your company. The uncompleted dollar value is to be based upon the most recent engineer's or owners estimate, and must include work subcontracted to others. If no work is contracted, show **NONE**.

	1	2	3	4	Awards Pending	
Contract Number						
Contract With						
Estimated Completion Date						
Total Contract Price						Accumulated Totals
Uncompleted Dollar Value if Firm is the Prime Contractor	4,112,825.00					\$4,112,825.00
Uncompleted Dollar Value if Firm is the Subcontractor	877,947.00					\$877,947.00
Total Value of All Work						\$4,990,772.00

Part II. Awards Pending and Uncompleted Work to be done with your own forces.

List below the uncompleted dollar value of work for each contract and awards pending to be completed with your own forces. All work subcontracted to others will be listed on the reverse of this form. In a joint venture, list only that portion of the work to be done by your company. If no work is contracted, show **NONE**.

					Accumulated Totals
Earthwork					
Portland Cement Concrete Paving					
HMA Plant Mix					
HMA Paving					
Clean & Seal Cracks/Joints					
Aggregate Bases & Surfaces					
Highway, R.R. and Waterway Structures					
Drainage					
Electrical					
Cover and Seal Coats					
Concrete Construction	REMOVAL	25,000.00			\$25,000.00
Landscaping	BRICKING	139,718.00			\$139,718.00
Fencing	URETHANE	442,642.00			\$442,642.00
Guardrail	POLYUREA	24,376.00			\$24,376.00
Painting	POLYMER	109,575.00			\$109,575.00
Signing					
Cold Milling, Planning & Rotomilling					
Demolition					
Pavement Markings (Paint)	Thermid	1,305,843.00			\$1,305,843.00
Other Construction (List)	rpm	2,943,618.00			\$2,943,618.00
					\$ 0.00
Totals		\$4,990,772.0			\$4,990,772.00

Disclosure of this information is **REQUIRED** to accomplish the statutory purpose as outlined in the "Illinois Procurement Code." Failure to comply will result in non-issuance of an "Authorization To Bid." This form has been approved by the State Forms Management Center.

Part III. Work Subcontracted to Others.

For each contract described in Part I, list all the work you have subcontracted to others.

	1	2	3	4	Awards Pending
Subcontractor					
Type of Work					
Subcontract Price					
Amount Uncompleted					
Subcontractor					
Type of Work					
Subcontract Price					
Amount Uncompleted					
Subcontractor					
Type of Work					
Subcontract Price					
Amount Uncompleted					
Subcontractor					
Type of Work					
Subcontract Price					
Amount Uncompleted					
Subcontractor					
Type of Work					
Subcontract Price					
Amount Uncompleted					
Total Uncompleted					

I, being duly sworn, do hereby declare that this affidavit is a true and correct statement relating to ALL uncompleted contracts of the undersigned for Federal, State, County, City and private work, including ALL subcontract work, ALL pending low bids not yet awarded or rejected and ALL estimated completion dates.

Subscribed and sworn to before me

this 20 day of FEBRUARY, 2019 Type or Print Name JOAN YARIO PRESIDENT
Officer or Director Title

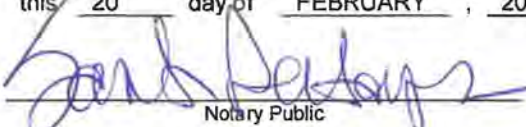
 Notary Public

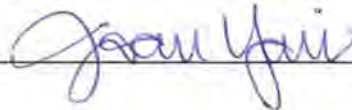
Signed 

My commission expires 02/23/2020



Company SUPERIOR ROAD STRIPING, INC.

Address 1980 N. HAWTHORNE AVE
MELROSE PARK IL 60160

VILLAGE OF BUFFALO GROVE PUBLIC CONTRACT STATEMENTS

The Village of Buffalo Grove is required to obtain certain information in the administration and awarding of public contracts. The following Public Contract Statements shall be executed and notarized.

PUBLIC CONTRACT STATEMENTS

CERTIFICATION OF CONTRACTOR/CONSULTANT

In order to comply with 720 Illinois Compiled Statutes 5/33 E-1 et seq., the Village of Buffalo Grove requires the following certification be acknowledged:

The below-signed Contractor/Consultant hereby certifies that it is not barred from Bidding or supplying any goods, services or construction let by the Village of Buffalo Grove with or without Bid, due to any violation of either Section 5/33 E-3 or 5/33 E-4 of Article 33E, Public Contracts, of the Chapter 720 of the Illinois Compiled Statutes, as amended. This act relates to interference with public contracting, Bid rigging and rotating, kickbacks, and Bidding.

CERTIFICATION RELATIVE TO 65 ILCS 5/11-42.1.1

In order to comply with 65 Illinois Compiled Statutes 5/11-42.1.1, the Village of Buffalo Grove requires the following certification:

The undersigned Contractor/Consultant does hereby swear and affirm that it is not delinquent in the payment of any tax administered by the Illinois Department of Revenue unless it is contesting, in accordance with the procedures established by the appropriate revenue Act, its liability for the tax or the amount of the tax. The undersigned further understands that making a false statement herein: (1) is a Class A Misdemeanor, and (2) voids the contract and allows the Village to recover all amounts paid to it under the contract.

CONFLICT OF INTEREST

The Village of Buffalo Grove Municipal Code requires the following verification relative to conflict of interest and compliance with general ethics requirements of the Village:

The undersigned Contractor/Consultant hereby represents and warrants to the Village of Buffalo Grove as a term and condition of acceptance of this (Proposal or purchase order) that none of the following Village Officials is either an officer or Manager of Firm or owns five percent (5%) or more of the Supplier: the Village President, the members of the Village Board of Trustees, the Village Clerk, the Village Treasurer, the members of the Zoning Board of Appeals and the Plan Commission, the Village Manager and his Assistant or Assistants, or the heads of the various departments within the Village.

If the foregoing representation and warranty is inaccurate, state the name of the Village official who either is an officer or Manager of your business entity or owns five percent (5%) or more thereof:

(Official) _____

Print Name of Contractor/Consultant

Signature

Title

Subscribed and Sworn to before me this _____ day of _____, 2019.

Notary Public

Notary Expiration Date _____

Sources: Esri, HERE, DeLorme, USGS, Intermap, INCREMENT P, NRCan, Esri Japan, METI, Esri China (Hong Kong), Esri Korea, Esri (Thailand), NGCC, © OpenStreetMap contributors, and the GIS User Community

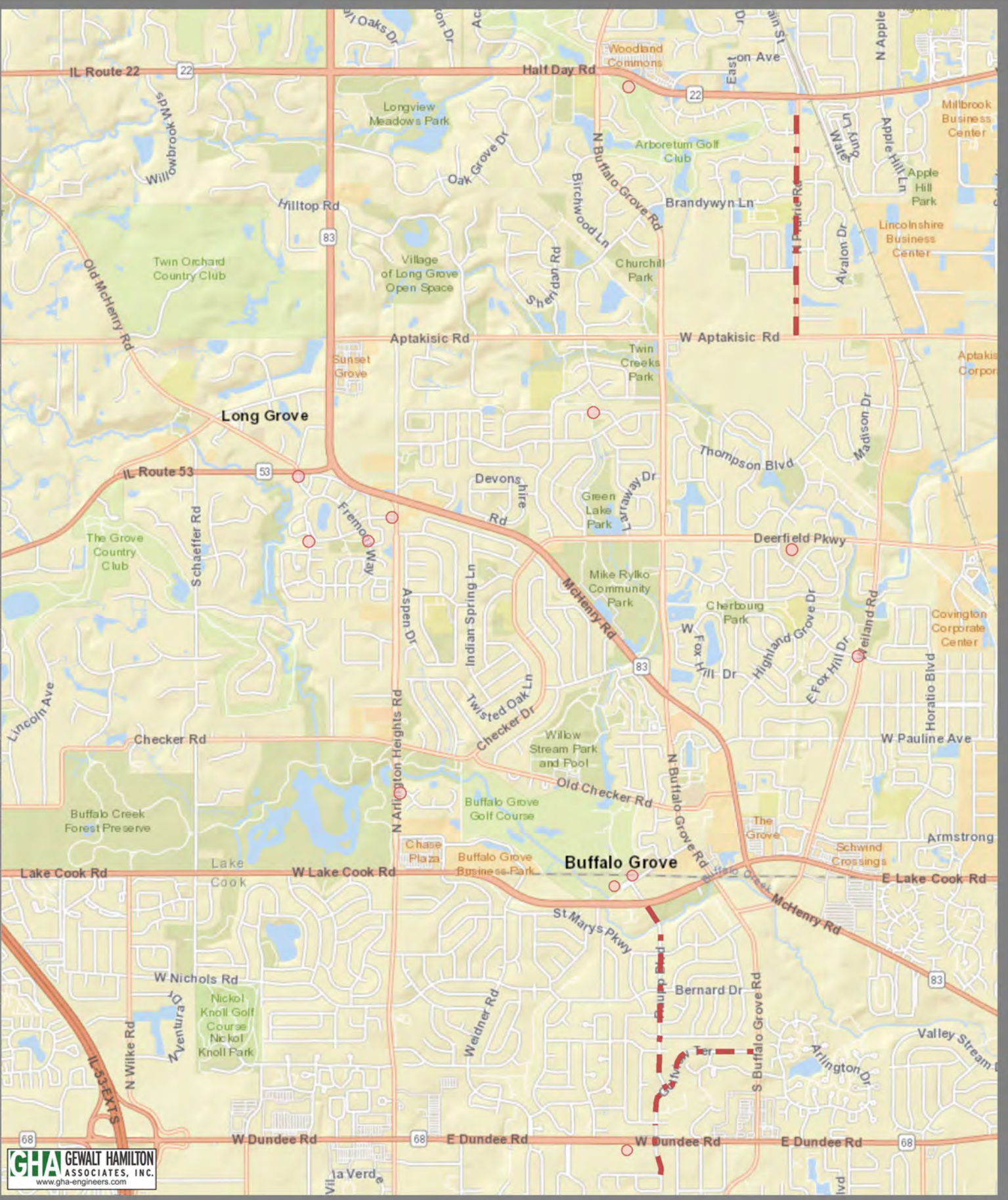

1 in = 2,500 ft

2019 Pavement Marking Program

VoBG-2019-09

**Description of Work
2019 Pavement Markings Project
Village of Buffalo Grove**

The following is a list of streets including limits, lengths, area, and a brief description of work:

Street	From/To
Raupp Boulevard	Lake Cook Rd to Golfview Terr
Golfview Terrace	Buffalo Grove Rd to Park View Terr
Auburn Lane	At Arlington Heights Rd
Newtown Drive	At Weiland Rd (West Leg)
Prairie Road	IL Rte 22 to Aptakisic Rd
Caren Drive	561 Caren Dr
Fremont Way	IL Rte 53 to Arlington Heights Rd
<u>Public Parking</u>	
Arboretum Club	401 Half Day Rd, Buffalo Grove, IL
Buffalo Grove Golf Club	48 Raupp Blvd, Buffalo Grove, IL
Fire Station 25	505 W Dundee Rd, Buffalo Grove, IL
Fire Station 26	1051 Highland Grove Dr, Buffalo Grove, IL

The above street segments and public parking will include thermoplastic pavement marking removal and replacement operations at various locations, and other associated traffic control requirements.

SUMMARY OF QUANTITIES

SP	ITEM NO	DESCRIPTION	UNIT	QUANTITY	Raupp Boulevard	Golfview Terrace	Auburn Lane	Newtown Drive	Prairie Road
	78000100	Thermoplastic Pavement Marking - Letters and Symbols	SF	565		40.0		65.0	420.0
	78000200	Thermoplastic Pavement Marking - Line 4"	FT	33,195	4,780.0	2,060.0		325.0	16,605.0
	78000400	Thermoplastic Pavement Marking - Line 6"	FT	2,175		285.0		80.0	1,480.0
	78000600	Thermoplastic Pavement Marking - Line 12"	FT	1,680	535.0		150.0		905.0
	78000650	Thermoplastic Pavement Marking - Line 24"	FT	325	90.0	80.0	20.0	35.0	35.0
*	X0327979	Pavement Marking Removal - Grinding	SF	14,745	2,340.0	1,045.0	190.0	290.0	7,780.0
*	X7010216	Traffic Control and Protection, (Special)	LS	1	0.09	0.09	0.09	0.09	0.10

* Special Provision Required

SUMMARY OF QUANTITIES

SP	ITEM NO	DESCRIPTION	UNIT	QUANTITY	Caren Drive	Fremont Way	Arboretum Club	Buffalo Grove Golf Club	Fire Station 25
	78000100	Thermoplastic Pavement Marking - Letters and Symbols	SF	565		40.0			
	78000200	Thermoplastic Pavement Marking - Line 4"	FT	33,195		410.0	4,920.0	3,070.0	570.0
	78000400	Thermoplastic Pavement Marking - Line 6"	FT	2,175	80.0	250.0			
	78000600	Thermoplastic Pavement Marking - Line 12"	FT	1,680		90.0			
	78000650	Thermoplastic Pavement Marking - Line 24"	FT	325		50.0		15.0	
*	X0327979	Pavement Marking Removal - Grinding	SF	14,745			1,675.0	1,075.0	195.0
*	X7010216	Traffic Control and Protection, (Special)	LS	1	0.09	0.09	0.09	0.09	0.09

* Special Provision Required

SUMMARY OF QUANTITIES

SP	ITEM NO	DESCRIPTION	UNIT	QUANTITY	Fire Station 26
	78000100	Thermoplastic Pavement Marking - Letters and Symbols	SF	565	
	78000200	Thermoplastic Pavement Marking - Line 4"	FT	33,195	455.0
	78000400	Thermoplastic Pavement Marking - Line 6"	FT	2,175	
	78000600	Thermoplastic Pavement Marking - Line 12"	FT	1,680	
	78000650	Thermoplastic Pavement Marking - Line 24"	FT	325	
*	X0327979	Pavement Marking Removal - Grinding	SF	14,745	155.0
*	X7010216	Traffic Control and Protection, (Special)	LS	1	0.09

* Special Provision Required



The Following Recurring Special Provisions Indicated By An "X" Are Applicable To This Contract And Are Included By Reference:

Recurring Special Provisions

<u>Check Sheet #</u>		<u>Page No.</u>
1	<input type="checkbox"/> Additional State Requirements for Federal-Aid Construction Contracts	75
2	<input type="checkbox"/> Subletting of Contracts (Federal-Aid Contracts)	78
3	<input type="checkbox"/> EEO	79
4	<input type="checkbox"/> Specific EEO Responsibilities Non Federal-Aid Contracts	89
5	<input type="checkbox"/> Required Provisions - State Contracts	94
6	<input type="checkbox"/> Asbestos Bearing Pad Removal	100
7	<input type="checkbox"/> Asbestos Waterproofing Membrane and Asbestos HMA Surface Removal	101
8	<input type="checkbox"/> Temporary Stream Crossings and In-Stream Work Pads	102
9	<input type="checkbox"/> Construction Layout Stakes Except for Bridges	103
10	<input type="checkbox"/> Construction Layout Stakes	106
11	<input type="checkbox"/> Use of Geotextile Fabric for Railroad Crossing	109
12	<input type="checkbox"/> Subsealing of Concrete Pavements	111
13	<input type="checkbox"/> Hot-Mix Asphalt Surface Correction	115
14	<input type="checkbox"/> Pavement and Shoulder Resurfacing	117
15	<input type="checkbox"/> Patching with Hot-Mix Asphalt Overlay Removal	118
16	<input type="checkbox"/> Polymer Concrete	120
17	<input type="checkbox"/> PVC Pipeliner	122
18	<input type="checkbox"/> Bicycle Racks	123
19	<input type="checkbox"/> Temporary Portable Bridge Traffic Signals	125
20	<input type="checkbox"/> Work Zone Public Information Signs	127
21	<input type="checkbox"/> Nighttime Inspection of Roadway Lighting	128
22	<input type="checkbox"/> English Substitution of Metric Bolts	129
23	<input type="checkbox"/> Calcium Chloride Accelerator for Portland Cement Concrete	130
24	<input type="checkbox"/> Quality Control of Concrete Mixtures at the Plant	131
25	<input type="checkbox"/> Quality Control/Quality Assurance of Concrete Mixtures	139
26	<input type="checkbox"/> Digital Terrain Modeling for Earthwork Calculations	155
27	<input type="checkbox"/> Reserved	157
28	<input type="checkbox"/> Preventive Maintenance - Bituminous Surface Treatment	158
29	<input type="checkbox"/> Reserved	164
30	<input type="checkbox"/> Reserved	165
31	<input type="checkbox"/> Reserved	166
32	<input type="checkbox"/> Temporary Raised Pavement Markers	167
33	<input type="checkbox"/> Restoring Bridge Approach Pavements Using High-Density Foam	168
34	<input type="checkbox"/> Portland Cement Concrete Inlay or Overlay	171
35	<input type="checkbox"/> Portland Cement Concrete Partial Depth Hot-Mix Asphalt Patching	175

The Following Local Roads And Streets Recurring Special Provisions Indicated By An "X" Are Applicable To This Contract And Are Included By Reference:

Local Roads And Streets Recurring Special Provisions

<u>Check Sheet #</u>		<u>Page No.</u>
LRS 1	Reserved	179
LRS 2	<input type="checkbox"/> Furnished Excavation	180
LRS 3	<input checked="" type="checkbox"/> Work Zone Traffic Control Surveillance	181
LRS 4	<input checked="" type="checkbox"/> Flaggers in Work Zones	182
LRS 5	<input checked="" type="checkbox"/> Contract Claims	183
LRS 6	<input checked="" type="checkbox"/> Bidding Requirements and Conditions for Contract Proposals	184
LRS 7	<input type="checkbox"/> Bidding Requirements and Conditions for Material Proposals	190
LRS 8	Reserved	196
LRS 9	<input type="checkbox"/> Bituminous Surface Treatments	197
LRS 10	Reserved	198
LRS 11	<input checked="" type="checkbox"/> Employment Practices	199
LRS 12	<input checked="" type="checkbox"/> Wages of Employees on Public Works	201
LRS 13	<input checked="" type="checkbox"/> Selection of Labor	203
LRS 14	<input type="checkbox"/> Paving Brick and Concrete Paver Pavements and Sidewalks	204
LRS 15	<input checked="" type="checkbox"/> Partial Payments	207
LRS 16	<input type="checkbox"/> Protests on Local Lettings	208
LRS 17	<input type="checkbox"/> Substance Abuse Prevention Program	209
LRS 18	<input type="checkbox"/> Multigrade Cold Mix Asphalt	210



Local Public Agency	County	Section Number
Village of Buffalo Grove	Cook	19-00000-00-GM

The following Special Provision supplement the "Standard Specifications for Road and Bridge Construction", adopted

April 1, 2016, the latest edition of the "Manual on Uniform Traffic Control Devices for Streets and Highways", and the "Manual of Test Procedures of Materials" in effect on the date of invitation of bids, and the Supplemental Specification and Recurring Special Provisions indicated on the Check Sheet included here in which apply to and govern the construction of the above named section, and in case of conflict with any parts, or parts of said Specifications, the said Special Provisions shall take precedence and shall govern.

2019 Pavement Markings Project

**TABLE OF CONTENTS
FOR CONTRACT SPECIAL PROVISIONS**

General Conditions

1. General Conditions
2. Definition of Village of Buffalo Grove
3. Reservation of Rights
4. Prequalification of Bidders
5. Completion Date
6. Contract Sequencing
7. Construction Work Periods
8. Pre-Construction Meeting
9. Authority of the Engineer
10. Traffic Control and Protection
11. Maintenance of Roadways
12. Maintenance Bond
13. Insurance Requirements
14. Certified Payroll Reports
15. Monetary Penalties

Special Provisions

1. Traffic Control and Protection

General Conditions

1. General Conditions

It is the policy of the Municipality and other governing agencies to set standards for the performance of road and bridge construction. This contract shall expressly adhere to the 'Standard Specifications for Road and Bridge Construction', latest edition, and the 'Standard Specifications for Water and Sewer Main Construction in Illinois', latest edition, unless otherwise specified herein.

2. Definition of Village of Buffalo Grove

All references in the contract relating to the Department, Awarding Authority, Village of Buffalo Grove, Village etc. shall mean the Village of Buffalo Grove.

3. Reservation of Rights

The Village reserves the following rights regarding the bidding process:

- A. The right to accept the Bid Proposal that is, in the Village's sole judgment, the best and most favorable to the interests of the Village and the public.
- B. To reject the lowest bidder.
- C. To accept any item or any portion in any Bid Proposal from any bidder.
- D. To accept and incorporate corrections, clarifications or modifications following the Bid Due Date when doing so would not, in the Village's opinion, prejudice the procurement process or create any improper advantage to any bidder.
- E. To waive irregularities and informalities in the procurement process or in any Bid Proposal; provided, however, that the waiver of any prior defect or informality shall not be considered a waiver of any future or similar defects or informalities, and bidders shall not rely upon, or anticipate, such waivers in submitting their Bid Proposal.
- F. To disqualify any bidder that is found to have contacted the Village's personnel in any manner with regard to the Work.
- G. The right to approve or disapprove of any or all subcontractors, or insist on no subcontractors, in connection with any Bid Proposal.
- H. Reject any subcontractor from working on the Work if they are not listed in the Bid Proposal.
- I. The Village shall hold the Bid Security from the two (2) lowest bidders until the Contract is signed for the Work.
- J. Disqualify any bidder who requests changes to the Contract when such changes were not submitted with their Bid Proposal.
- K. To remove from or add to the project any portions thereof included in the 2019 Pavement Marking Program. Such reductions, if any, shall be made in writing by the Village prior to execution of the Contract Documents. Any reduction in the scope of work required by the Village prior to the execution of the Contract Documents shall result in an adjustment to the contract or to the price originally bid.

4. Prequalification of Bidders

Bidders shall be prequalified with the Illinois Department of Transportation in accordance with Article 102.01 of the Standard Specifications and is required by all bidders.

All bidders are required to fully register with the Village of Buffalo Grove, including IRS Form W-9, at:

<https://vrapp.vendorregistry.com/Vendor/Register/Index/buffalo-grove-village-of-il-vendor-registration>

OR

www.vbg.org/bids

Select the link 'Register My Business'

Please contact Vendor Registry at (844) 802-9202 for assistance in the registration process.

The Village of Buffalo Grove reserves the right to reject any or all proposals if the bidder does not comply with the requirements as stated herein.

5. Completion Date

The Contractor shall commence the work to be performed under this contract, on or near Tuesday, May 28, 2019. The work shall be prosecuted in such a manner and with such a supply of materials, equipment and labor as considered necessary to ensure its completion according to the time specified in the contract. The Contractor shall complete all work in the contract by **Wednesday, July 3, 2019**, including punch list items, as defined in Article 108.04 of the Standard Specifications. It is the Village's intent to complete this project following the completion of other Village projects, therefore, the Engineer will be in contact with the Contractor to verify the commencement date and schedule accordingly.

In case of failure to complete the work on time, the provisions of Article 108.09 of the Standard Specifications shall apply.

The estimated Village Board award date for this project is Monday, March 18, 2019.

6. Contract Sequencing

The Contractor shall notify the Engineer at least 72 hours in advance of beginning work in each respective municipality and 48 hours prior to construction commencement on each subsequent street. Construction operations shall be conducted in a manner such that streets will remain open to all traffic. At no time shall residents or business owners be kept out of their driveway over a weekend or holiday as defined in article 107.09 of the Standard Specifications.

Work shall be scheduled so that it is continuous on the various roadways. The Contractor and approved Subcontractor(s) shall, at all times, employ and provide sufficient labor, tools, equipment, and other incidental items for prosecuting the work to full completion in the manner and time required by the contract.

7. Construction Work Periods

Construction operations shall be completed in accordance with Article 107.09 of the Standard Specifications. All work shall be confined to the period beginning at 7:00 AM and ending at 6:00 PM on weekdays. No work shall be done on weekends or legal holiday periods as defined in Article 107.09 of the Standard Specifications.

The proposed improvements at the Arboretum Club and the Buffalo Grove Golf Club may be required to be completed overnight due to staging and phasing. No additional compensation will be considered due to the Contractor for not adhering to this general condition. The Village will be open to other staging considerations in order to complete this work with the least amount of public inconveniences.

Any work outside the allowed time periods specified including but not limited to, material deliveries, mobilization of equipment, warming up machinery, and mobilization of equipment, a penalty of \$1,000 per occurrence may be imposed, exclusive of the above-referenced proposed overnight work.

8. Pre-Construction Meeting

Prior to commencing any construction operations, there shall be a pre-construction meeting. The Owner or Engineer will set the time and date of the meeting following Contract award.

The following shall be submitted by the Contractor for review at the pre-construction meeting:

A Progress Schedule in accordance with Article 108.02.

The 24-hour emergency phone number and contact information of the assigned Contractor's superintendent, or otherwise.

The name and 24-hour emergency phone number of the person in the direct employ of the Contractor who is responsible for administering the Traffic Control and Protection on the Contract

A list of subcontractors with contact information, including but not limited to name, phone number, and email address, and include quantity and type of work to be sublet for each respective subcontractor in accordance with Article 108.01 of the Standard Specifications.

A list of proposed sources of material.

Hot-mix asphalt and concrete mix designs, and respective quality control plans.

Any applicable shop drawing submittals.

9. Authority of the Engineer

Revise Article 105.01 Authority of Engineer to read:

"All work shall be done in accordance with the requirements of the Contract, the Engineer shall have the right, but not the obligation, to observe all work. The Engineer shall decide all questions that arise as to the interpretation of the Plans and Specifications and as to disputes and mutual rights between Contractors under the Specifications. The Engineer shall advise the Village of Buffalo Grove as to the quality and acceptability of materials furnished and work performed, rate of progress of the work, and acceptable fulfillment of the Contract. The Engineer will determine the amount of materials furnished and work performed. The Engineer's advice and determinations shall be conditions precedent to the right of the Contractor to receive money due the Contractor under the Contract."

"The Engineer will notify the Contractor in writing if the work is to be suspended by the Village of Buffalo Grove wholly or in part due to the failure of the Contractor to carry out provisions of the contract; for failure to carry out orders; for such periods due to unsuitable weather; for conditions considered unsuitable for the prosecution of the work or for any other condition or reason deemed to be in the public interest."

"In case of failure on the part of the Contractor to execute work as directed by the Engineer, the Village of Buffalo Grove may, at the expiration of a period of 48 hours after giving notice in writing to the Contractor, proceed to execute such work as may be deemed necessary, and the cost thereof shall be deducted from compensation due or which may become due to the Contractor under the contract."

The Engineer shall not assume any of the responsibilities of the Contractor's superintendent or of subcontractors; shall not expedite the work for the Contractor; and shall not advise on, or issue directions concerning aspects of construction means, methods, techniques, sequences or procedures, or safety precautions in connection with the work.

10. Traffic Control and Protection

Effective: September 30, 1985

Revised: January 1, 2007

Traffic Control shall be according to the applicable sections of the Standard Specifications, the Supplemental Specifications, the "Illinois Manual on Uniform Traffic Control Devices for Streets and Highways", any special details and Highway Standards contained in the plans, and the Special Provisions contained herein.

Special attention is called to Article 107.09 of the Standard Specifications and the following Highway Standards, Details, Quality Standard for Work Zone Traffic Control Devices, Recurring Special Provisions and Special Provisions contained herein, relating to traffic control.

Delays to the Contractor caused by complying with these requirements will be considered included in the cost of the contract, and no additional compensation will be allowed.

Standards
701311 and 701901

Details

TC-13 District One Typical Pavement Markings

Special Provisions

Maintenance of Roadways

LRS 3 – Work Zone Traffic Control Surveillance

LRS 4 – Flaggers in Work Zones

11. Maintenance of Roadways

Effective: September 30, 1985

Revised: November 1, 1996

Beginning on the date that the Contractor begins work on this project, he shall assume responsibility for normal maintenance of all existing roadways within the limits of the improvement. This normal maintenance shall include all repair work deemed necessary by the Engineer, but shall not include snow removal operations. Traffic control and protection for maintenance of roadways will be provided by the Contractor as required by the Engineer.

If items of work have not been provided for in the contract, or otherwise specified for payment, such items, including the accompanying traffic control and protection required by the Engineer, will be paid for in accordance with Article 109.04 of the Standard Specifications.

12. Maintenance Bond

The Contractor will be required to post a Maintenance Bond for a period of One Year (1-yr) from date of final acceptance by the Village. Final acceptance will be the date the Final Payment is made to the Contractor. The bond shall be in a form acceptable to the Village in the amount of 10% (ten percent) of the awarded contract value. Unless under emergency situations, the Village will offer the Contractor the ability to fix or repair any item prior to the bond being called. If the Contractor elects to perform the repairs themselves, all work must be complete within 14 calendar days of notice from the Village or the Village reserves the right to perform the repairs themselves.

The Maintenance Bond shall cover all necessary repairs or replacements as deemed necessary by the Village due to poor workmanship, failed materials, settlement of trenches, excessively spalled, chert popped or cracked concrete, storm and water main failures, restoration establishment, and other items as completed by the Contractor.

All required pavement repairs shall be from curb line to the nearest cold joint. Pavement repairs shall have all joints routed and filled with crack seal material including along the edge of pavement 1 month after installation.

If the Contractor elects to not perform the repairs or does not perform them in the time allotted the Village will perform the work and collect from the bond any damages incurred by the Village to perform the repairs.

13. Insurance Requirements

12.04.080 - Insurance.

A. Required Coverages and Limits. Unless otherwise provided by franchise, license, or similar agreement, each Contractor occupying right-of-way or constructing any facility in the right-of-way shall secure and maintain the following liability insurance policies insuring the Contractor as named insured and naming the Village, and its elected and appointed officers, officials, agents, and employees as additional insureds on the policies listed in subsection (A)(1) and (A)(2) of this section:

1. Commercial general liability insurance, including premises-operations, explosion, collapse, and underground hazard (commonly referred to as "X," "C," and "U" coverages) and products-completed operations coverage with limits not less than:
 - a. Five million dollars for bodily injury or death to each person,
 - b. Five million dollars for property damage resulting from any one accident, and
 - c. Five million dollars for all other types of liability;
2. Automobile liability for owned, non-owned and hired vehicles with a combined single limit of one million dollars for personal injury and property damage for each accident;

3. Worker's compensation with statutory limits; and
4. Employer's liability insurance with limits of not less than one million dollars per employee and per accident.

If the Contractor is not providing such insurance to protect the contractors and subcontractors performing the work, then such contractors and subcontractors shall comply with this section.

- B. **Excess or Umbrella Policies.** The coverages required by this section may be in any combination of primary, excess, and umbrella policies. Any excess or umbrella policy must provide excess coverage over underlying insurance on a following-form basis such that when any loss covered by the primary policy exceeds the limits under the primary policy, the excess or umbrella policy becomes effective to cover such loss.
- C. **Copies Required.** The Contractor shall provide copies of any of the policies including all endorsements or certificates required by this section to the Village within ten calendar days following receipt of a written request therefor from the Village.
- D. **Maintenance and Renewal of Required Coverages.** The insurance policies required by this section shall contain the following endorsement:

"It is hereby understood and agreed that this policy may not be canceled nor the intention not to renew be stated until thirty (30) calendar days after receipt by the Village, by registered mail or certified mail, return receipt requested, of a written notice addressed to the Village Manager of such intent to cancel or not to renew."

Within ten (10) calendar days after receipt by the Village of said notice, and in no event later than ten (10) calendar days prior to said cancellation, the Contractor shall obtain and furnish to the Village evidence of replacement insurance policies meeting the requirements of this section.

- E. **Self-Insurance.** A Contractor may self-insure all or a portion of the insurance coverage and limit requirements required by subsection A of this section. A Contractor that self-insures is not required, to the extent of such self-insurance, to comply with the requirement for the naming of additional insureds under subsection A of this section, or the requirements of subsections B through D of this section. A Contractor that elects to self-insure shall provide to the Village evidence sufficient to demonstrate its financial ability to self-insure the insurance coverage and limit requirements required under subsection A of this section, such as evidence that the Contractor is a "private self insurer" under the Workers Compensation Act.
- F. **Effect of Insurance and Self-Insurance on Contractor's Liability.** The legal liability of the Contractor to the Village and any person for any of the matters that are the subject of the insurance policies or self-insurance required by this section shall not be limited by such insurance policies or self-insurance or by the recovery of any amounts thereunder.
- G. **Insurance Companies.** All insurance provided pursuant to this section shall be effected under valid and enforceable policies, issued by insurers legally able to conduct business with the licensee in the State of Illinois. All insurance carriers and surplus line carriers shall be rated "A-" or better and of a class size "X" or higher by A.M. Best Company.

Nothing contained herein is intended to constitute, nor shall it constitute a waiver of the rights, defenses and/or other immunities provided or available to the Village under law including, but not limited to, the Local Governmental and Governmental Employees Tort Immunity Act.

14. Certified Payroll Reports

The Village of Buffalo Grove requests that the Contractor submit all certified payroll reports, including subcontractors, and EEO reporting be sent electronically in separate files for each respective Contractor/subcontractor with the weeks ending date in the file name to kjohnson@vbq.org (i.e. Contractor Name_Week Ending.pdf) as shown in the sample letter in Appendix A.

The Contractor is responsible for providing all records in accordance with the Illinois Department of Labor's (IDOL) requirements pertaining to the Prevailing Wage Act on the standard IDOL form. Only the last four (4) digits of the employee's social security number will be required; the remaining digits shall be "X" or redacted. To complete the certified payroll request for release of payment, the Contractor must supply a signed and notarized written statement that all necessary documentation has been turned over for the pay period pertaining to that payment requested.

Under P.A. 98-0328, the public body must retain copies of the certified payroll for 5 years rather than 3 years as was the case previously. The Illinois Department of Labor (IDOL) has created model certified payroll forms which can be found at the IDOL website www.illinois.gov/idol. The new form consists of three pages identified as the "certified transcript of payroll affidavit" and "certified transcript of payroll instructions". The new forms on the IDOL website can be filled in online and then printed out. under P.A. 98-0482, contractors

and subcontractors will have to provide additional information with respect to working hours, wage rates, overtime rates and fringe benefits. The IDOL's model certified payroll forms are the most current forms for compliance with P.A. 98-0482 and should be used in public works contracts.

15. Monetary Penalties

All work shall be completed in accordance with the Contract Documents in a reasonable and timely manner. For each occurrence that work is not completed in a reasonable and timely manner, a monetary penalty will be deducted from the final pay application. The Contractor shall make themselves and all subcontractors aware of the following deficiency and deductions:

Description	Penalty	Per Occurrence
Failure to Sweep Roadway	\$250	Calendar Day
Failure to Maintain Trench	\$250	Calendar Day
Failure to Adhere to Period of Establishment Requirements	\$250	Calendar Day
Distributing Unapproved Resident Notices	\$100	Household
Failure to Distribute Notices in a Timely Manner	\$100	Household
Failure to Distribute Notice to Resident	\$100	Household
Failure to Provide Access in a Timely Manner	\$250	Household Per Day
Failure to Provide Weekly Update to Engineer	\$1,000	Per Occurrence
Failure to Attend a Scheduled Weekly Meeting	\$1,000	Per Occurrence
Failure to Respond in a Timely Manner to a Resident	\$250	Calendar Day
Failure to Ramp Roadway or Driveway	\$250	Household/Roadway Per Day
Use of Fire Hydrant or Valve	\$1,000	Each
Failure to Provide Maintenance of Roadway in a Timely Manner as Determined by the Engineer	\$1,000	Calendar Day
Entering Private Property	\$500	Per Occurrence
Failure to Provide Portable Facilities	\$100	Calendar Day
Illicit Discharge of Silt or Construction Debris	\$1,000	Per Occurrence
Failure to Submit Shop Drawings on Time	\$500	Per Occurrence
Failure to Maintain Erosion and/or Sediment Control Devices	\$1,000	Per Occurrence
Working Outside Allowable Work Hours	\$1,000	Per Occurrence

At the discretion of the Engineer and without notice, the Contractor shall have deducted the monetary penalty amount as listed above for each occurrence on the final pay application.

Special Provisions

1. Traffic Control and Protection

This work shall include all labor, material, and equipment necessary to furnish, install, maintain, and remove traffic control and protection measures in accordance with Section 701 of the Standard Specifications and as specified herein.

All applicable details and general conditions shall be included in the cost of this item.

Delays to the Contractor caused by complying with these requirements will be considered included in the cost of the contract, and no additional compensation will be allowed.

The Contractor shall be properly advised of the regulated weight limits within the surrounding areas of the project. No additional compensation in time nor monetary value will be allowed. The Village of Buffalo Grove Police Department requires permits for Overweight/Over Sized Trucks or Vehicles. The Contractor can find additional information at www.vbg.org/645/Truck-Enforcement or by calling (847) 459-2560.

This work will be measured in place and paid for at the contract unit price per lump sum (LS) for TRAFFIC CONTROL AND PROTECTION (SPECIAL), which shall include all labor, material, and equipment required to complete the work as specified herein.

BDE SPECIAL PROVISIONS
For the January 18, 2019 and March 8, 2019 Lettings

The following special provisions indicated by a "check mark" are applicable to this contract and will be included by the Project Coordination and Implementation Section of the BD&E. An * indicates a new or revised special provision for the letting.

File Name	#		Special Provision Title	Effective	Revised
	80099	1	<input type="checkbox"/> Accessible Pedestrian Signals (APS)	April 1, 2003	Jan. 1, 2014
	80274	2	<input type="checkbox"/> Aggregate Subgrade Improvement	April 1, 2012	April 1, 2016
	80192	3	<input type="checkbox"/> Automated Flagger Assistance Device	Jan. 1, 2008	
	80173	4	<input type="checkbox"/> Bituminous Materials Cost Adjustments	Nov. 2, 2006	Aug. 1, 2017
	80241	5	<input type="checkbox"/> Bridge Demolition Debris	July 1, 2009	
	50261	6	<input type="checkbox"/> Building Removal-Case I (Non-Friable and Friable Asbestos)	Sept. 1, 1990	April 1, 2010
	50481	7	<input type="checkbox"/> Building Removal-Case II (Non-Friable Asbestos)	Sept. 1, 1990	April 1, 2010
	50491	8	<input type="checkbox"/> Building Removal-Case III (Friable Asbestos)	Sept. 1, 1990	April 1, 2010
	50531	9	<input type="checkbox"/> Building Removal-Case IV (No Asbestos)	Sept. 1, 1990	April 1, 2010
*	80404	10	<input type="checkbox"/> Coarse Aggregate Quality for Micro-Surfacing and Cape Seals	Jan. 1, 2019	
	80384	11	<input checked="" type="checkbox"/> Compensable Delay Costs	June 2, 2017	
	80198	12	<input type="checkbox"/> Completion Date (via calendar days)	April 1, 2008	
	80199	13	<input type="checkbox"/> Completion Date (via calendar days) Plus Working Days	April 1, 2008	
	80293	14	<input type="checkbox"/> Concrete Box Culverts with Skews > 30 Degrees and Design Fills ≤ 5 Feet	April 1, 2012	July 1, 2016
	80311	15	<input type="checkbox"/> Concrete End Sections for Pipe Culverts	Jan. 1, 2013	April 1, 2016
	80277	16	<input type="checkbox"/> Concrete Mix Design – Department Provided	Jan. 1, 2012	April 1, 2016
	80261	17	<input checked="" type="checkbox"/> Construction Air Quality – Diesel Retrofit	June 1, 2010	Nov. 1, 2014
	80387	18	<input type="checkbox"/> Contrast Preformed Plastic Pavement Marking	Nov. 1, 2017	
	80029	19	<input type="checkbox"/> Disadvantaged Business Enterprise Participation	Sept. 1, 2000	April 2, 2018
	80402	20	<input checked="" type="checkbox"/> Disposal Fees	Nov. 1, 2018	
	80378	21	<input type="checkbox"/> Dowel Bar Inserter	Jan. 1, 2017	Jan. 1, 2018
*	80405	22	<input type="checkbox"/> Elastomeric Bearings	Jan. 1, 2019	
	80388	23	<input checked="" type="checkbox"/> Equipment Parking and Storage	Nov. 1, 2017	
	80229	24	<input type="checkbox"/> Fuel Cost Adjustment	April 1, 2009	Aug. 1, 2017
	80304	25	<input type="checkbox"/> Grooving for Recessed Pavement Markings	Nov. 1, 2012	Nov. 1, 2017
	80246	26	<input type="checkbox"/> Hot-Mix Asphalt – Density Testing of Longitudinal Joints	Jan. 1, 2010	Aug. 1, 2018
*	80406	27	<input type="checkbox"/> Hot-Mix Asphalt – Mixture Design Verification and Production (Modified for I-FIT Projects)	Jan. 1, 2019	
*	80398	28	<input type="checkbox"/> Hot-Mix Asphalt – Longitudinal Joint Sealant	Aug. 1, 2018	Jan. 1, 2019
	80399	29	<input type="checkbox"/> Hot-Mix Asphalt – Oscillatory Roller	Aug. 1, 2018	Nov. 1, 2018
	80347	30	<input type="checkbox"/> Hot-Mix Asphalt – Pay for Performance Using Percent Within Limits – Jobsite Sampling	Nov. 1, 2014	Aug. 1, 2018
*	80383	31	<input type="checkbox"/> Hot-Mix Asphalt – Quality Control for Performance	April 1, 2017	Jan. 1, 2019
	80376	32	<input type="checkbox"/> Hot-Mix Asphalt – Tack Coat	Nov. 1, 2016	
	80392	33	<input checked="" type="checkbox"/> Lights on Barricades	Jan. 1, 2018	
	80336	34	<input type="checkbox"/> Longitudinal Joint and Crack Patching	April 1, 2014	April 1, 2016
*	80393	35	<input type="checkbox"/> Manholes, Valve Vaults, and Flat Slab Tops	Jan. 1, 2018	Jan. 1, 2019
	80400	36	<input type="checkbox"/> Mast Arm Assembly and Pole	Aug. 1, 2018	
	80045	37	<input type="checkbox"/> Material Transfer Device	June 15, 1999	Aug. 1, 2014
	80394	38	<input type="checkbox"/> Metal Flared End Section for Pipe Culverts	Jan. 1, 2018	April 1, 2018
	80165	39	<input type="checkbox"/> Moisture Cured Urethane Paint System	Nov. 1, 2006	Jan. 1, 2010
	80349	40	<input type="checkbox"/> Pavement Marking Blackout Tape	Nov. 1, 2014	April 1, 2016
	80371	41	<input checked="" type="checkbox"/> Pavement Marking Removal	July 1, 2016	
	80390	42	<input type="checkbox"/> Payments to Subcontractors	Nov. 2, 2017	
	80389	43	<input type="checkbox"/> Portland Cement Concrete	Nov. 1, 2017	
	80359	44	<input type="checkbox"/> Portland Cement Concrete Bridge Deck Curing	April 1, 2015	Nov. 1, 2017
	80401	45	<input type="checkbox"/> Portland Cement Concrete Pavement Connector for Bridge Approach Slab	Aug. 1, 2018	

80300	46	<input type="checkbox"/>	Preformed Plastic Pavement Marking Type D - Inlaid	April 1, 2012	April 1, 2016
80328	47	<input checked="" type="checkbox"/>	Progress Payments	Nov. 2, 2013	
34261	48	<input type="checkbox"/>	Railroad Protective Liability Insurance	Dec. 1, 1986	Jan. 1, 2006
80157	49	<input type="checkbox"/>	Railroad Protective Liability Insurance (5 and 10)	Jan. 1, 2006	
* 80306	50	<input type="checkbox"/>	Reclaimed Asphalt Pavement (RAP) and Reclaimed Asphalt Shingles (RAS)	Nov. 1, 2012	Jan. 1, 2019
* 80407	51	<input type="checkbox"/>	Removal and Disposal of Regulated Substances	Jan. 1, 2019	
80395	52	<input type="checkbox"/>	Sloped Metal End Section for Pipe Culverts	Jan. 1, 2018	
80340	53	<input type="checkbox"/>	Speed Display Trailer	April 2, 2014	Jan. 1, 2017
80127	54	<input type="checkbox"/>	Steel Cost Adjustment	April 2, 2004	Aug. 1, 2017
* 80408	55	<input type="checkbox"/>	Steel Plate Beam Guardrail Manufacturing	Jan. 1, 2019	
80397	56	<input type="checkbox"/>	Subcontractor and DBE Payment Reporting	April 2, 2018	
80391	57	<input type="checkbox"/>	Subcontractor Mobilization Payments	Nov. 2, 2017	
80317	58	<input type="checkbox"/>	Surface Testing of Hot-Mix Asphalt Overlays	Jan. 1, 2013	April 1, 2016
80298	59	<input type="checkbox"/>	Temporary Pavement Marking	April 1, 2012	April 1, 2017
20338	60	<input type="checkbox"/>	Training Special Provisions	Oct. 15, 1975	
80403	61	<input type="checkbox"/>	Traffic Barrier Terminal, Type 1 Special	Nov. 1, 2018	
* 80409	62	<input checked="" type="checkbox"/>	Traffic Control Devices - Cones	Jan. 1, 2019	
* 80410	63	<input type="checkbox"/>	Traffic Spotters	Jan. 1, 2019	
80318	64	<input type="checkbox"/>	Traversable Pipe Grate for Concrete End Sections	Jan. 1, 2013	Jan. 1, 2018
80288	65	<input type="checkbox"/>	Warm Mix Asphalt	Jan. 1, 2012	April 1, 2016
80302	66	<input type="checkbox"/>	Weekly DBE Trucking Reports	June 2, 2012	April 2, 2015
80071	67	<input type="checkbox"/>	Working Days	Jan. 1, 2002	

The following special provisions are in the 2019 Supplemental Specifications and Recurring Special Provisions.

<u>File Name</u>	<u>Special Provision Title</u>	<u>New Location(s)</u>	<u>Effective</u>	<u>Revised</u>
80382	Adjusting Frames and Grates	Articles 602.02(s) and (t), 1043.04, and 1043.05	April 1, 2017	
80366	Butt Joints	Article 406.08(c)	July 1, 2016	
80386	Calcium Aluminate Cement for Class PP-5 Concrete Patching	Article 1001.01(e)	Nov. 1, 2017	
80396	Class A and B Patching	Articles 442.06(a)(1) and (2)	Jan. 1, 2018	Nov. 1, 2018
80377	Portable Changeable Message Signs	Articles 701.20(h) and 1106.02(i)	Nov. 1, 2016	April 1, 2017
80385	Portland Cement Concrete Sidewalk	Article 424.12	Aug. 1, 2017	

The following special provisions require additional information from the designer. The additional information needs to be submitted as a separate document. The Project Coordination and Implementation section will then include the information in the applicable special provision.

- Bridge Demolition Debris
- Building Removal - Case I
- Building Removal - Case II
- Building Removal - Case III
- Building Removal-Case IV
- Completion Date
- Completion Date Plus Working Days
- DBE Participation
- Material Transfer Device
- Railroad Protective Liability Insurance
- Training Special Provisions
- Working Days

COMPENSABLE DELAY COSTS (BDE)

Effective: June 2, 2017

Revise Article 107.40(b) of the Standard Specifications to read:

“(b) Compensation. Compensation will not be allowed for delays, inconveniences, or damages sustained by the Contractor from conflicts with facilities not meeting the above definition; or if a conflict with a utility in an unanticipated location does not cause a shutdown of the work or a documentable reduction in the rate of progress exceeding the limits set herein. The provisions of Article 104.03 notwithstanding, compensation for delays caused by a utility in an unanticipated location will be paid according to the provisions of this Article governing minor and major delays or reduced rate of production which are defined as follows.

- (1) Minor Delay. A minor delay occurs when the work in conflict with the utility in an unanticipated location is completely stopped for more than two hours, but not to exceed two weeks.
- (2) Major Delay. A major delay occurs when the work in conflict with the utility in an unanticipated location is completely stopped for more than two weeks.
- (3) Reduced Rate of Production Delay. A reduced rate of production delay occurs when the rate of production on the work in conflict with the utility in an unanticipated location decreases by more than 25 percent and lasts longer than seven calendar days.”

Revise Article 107.40(c) of the Standard Specifications to read:

“(c) Payment. Payment for Minor, Major, and Reduced Rate of Production Delays will be made as follows.

- (1) Minor Delay. Labor idled which cannot be used on other work will be paid for according to Article 109.04(b)(1) and (2) for the time between start of the delay and the minimum remaining hours in the work shift required by the prevailing practice in the area.

Equipment idled which cannot be used on other work, and which is authorized to standby on the project site by the Engineer, will be paid for according to Article 109.04(b)(4).

- (2) Major Delay. Labor will be the same as for a minor delay.

Equipment will be the same as for a minor delay, except Contractor-owned equipment will be limited to two weeks plus the cost of move-out to either the Contractor’s yard or another job and the cost to re-mobilize, whichever is less.

Rental equipment may be paid for longer than two weeks provided the Contractor presents adequate support to the Department (including lease agreement) to show retaining equipment on the job is the most economical course to follow and in the public interest.

- (3) Reduced Rate of Production Delay. The Contractor will be compensated for the reduced productivity for labor and equipment time in excess of the 25 percent threshold for that portion of the delay in excess of seven calendar days. Determination of compensation will be in accordance with Article 104.02, except labor and material additives will not be permitted.

Payment for escalated material costs, escalated labor costs, extended project overhead, and extended traffic control will be determined according to Article 109.13.”

Revise Article 108.04(b) of the Standard Specifications to read:

“(b) No working day will be charged under the following conditions.

- (1) When adverse weather prevents work on the controlling item.
- (2) When job conditions due to recent weather prevent work on the controlling item.
- (3) When conduct or lack of conduct by the Department or its consultants, representatives, officers, agents, or employees; delay by the Department in making the site available; or delay in furnishing any items required to be furnished to the Contractor by the Department prevents work on the controlling item.
- (4) When delays caused by utility or railroad adjustments prevent work on the controlling item.
- (5) When strikes, lock-outs, extraordinary delays in transportation, or inability to procure critical materials prevent work on the controlling item, as long as these delays are not due to any fault of the Contractor.
- (6) When any condition over which the Contractor has no control prevents work on the controlling item.”

Revise Article 109.09(f) of the Standard Specifications to read:

- “(f) Basis of Payment. After resolution of a claim in favor of the Contractor, any adjustment in time required for the work will be made according to Section 108. Any adjustment in the costs to be paid will be made for direct labor, direct materials, direct equipment, direct jobsite overhead, direct offsite overhead, and other direct costs allowed by the resolution. Adjustments in costs will not be made for interest charges, loss of anticipated profit, undocumented loss of efficiency, home office overhead and unabsorbed overhead

other than as allowed by Article 109.13, lost opportunity, preparation of claim expenses and other consequential indirect costs regardless of method of calculation.

The above Basis of Payment is an essential element of the contract and the claim cost recovery of the Contractor shall be so limited.”

Add the following to Section 109 of the Standard Specifications.

“109.13 Payment for Contract Delay. Compensation for escalated material costs, escalated labor costs, extended project overhead, and extended traffic control will be allowed when such costs result from a delay meeting the criteria in the following table.

Contract Type	Cause of Delay	Length of Delay
Working Days	Article 108.04(b)(3) or Article 108.04(b)(4)	No working days have been charged for two consecutive weeks.
Completion Date	Article 108.08(b)(1) or Article 108.08(b)(7)	The Contractor has been granted a minimum two week extension of contract time, according to Article 108.08.

Payment for each of the various costs will be according to the following.

- (a) Escalated Material and/or Labor Costs. When the delay causes work, which would have otherwise been completed, to be done after material and/or labor costs have increased, such increases will be paid. Payment for escalated material costs will be limited to the increased costs substantiated by documentation furnished by the Contractor. Payment for escalated labor costs will be limited to those items in Article 109.04(b)(1) and (2), except the 35 percent and 10 percent additives will not be permitted.
- (b) Extended Project Overhead. For the duration of the delay, payment for extended project overhead will be paid as follows.
 - (1) Direct Jobsite and Offsite Overhead. Payment for documented direct jobsite overhead and documented direct offsite overhead, including onsite supervisory and administrative personnel, will be allowed according to the following table.

Original Contract Amount	Supervisory and Administrative Personnel
Up to \$5,000,000	One Project Superintendent
Over \$ 5,000,000 - up to \$25,000,000	One Project Manager, One Project Superintendent or Engineer, and One Clerk
Over \$25,000,000 - up to \$50,000,000	One Project Manager, One Project Superintendent, One Engineer, and

	One Clerk
Over \$50,000,000	One Project Manager, Two Project Superintendents, One Engineer, and One Clerk

(2) Home Office and Unabsorbed Overhead. Payment for home office and unabsorbed overhead will be calculated as 8 percent of the total delay cost.

(c) Extended Traffic Control. Traffic control required for an extended period of time due to the delay will be paid. For working day contracts the payment will be made according to Article 109.04. For completion date contracts, an adjustment will be determined as follows.

Extended Traffic Control occurs between April 1 and November 30:

$$\text{ETCP Adjustment (\$)} = \text{TE} \times (\% / 100 \times \text{CUP} / \text{OCT})$$

Extended Traffic Control occurs between December 1 and March 31:

$$\text{ETCP Adjustment (\$)} = \text{TE} \times 1.5 (\% / 100 \times \text{CUP} / \text{OCT})$$

Where: TE = Duration of approved time extension in calendar days.

% = Percent maintenance for the traffic control, % (see table below).

CUP = Contract unit price for the traffic control pay item in place during the delay.

OCT = Original contract time in calendar days.

Original Contract Amount	Percent Maintenance
Up to \$2,000,000	65%
\$2,000,000 to \$10,000,000	75%
\$10,000,000 to \$20,000,000	85%
Over \$20,000,000	90%

When an ETCP adjustment is paid under this provision, an adjusted unit price as provided for in Article 701.20(a) for increase or decrease in the value of work by more than ten percent will not be paid.

Upon payment for a contract delay under this provision, the Contractor shall assign subrogation rights to the Department for the Department's efforts of recovery from any other party for monies paid by the Department as a result of any claim under this provision. The Contractor shall fully cooperate with the Department in its efforts to recover from another party any money paid to the Contractor for delay damages under this provision."

CONSTRUCTION AIR QUALITY – DIESEL RETROFIT (BDE)

Effective: June 1, 2010

Revised: November 1, 2014

The reduction of emissions of particulate matter (PM) for off-road equipment shall be accomplished by installing retrofit emission control devices. The term “equipment” refers to diesel fuel powered devices rated at 50 hp and above, to be used on the jobsite in excess of seven calendar days over the course of the construction period on the jobsite (including rental equipment).

Contractor and subcontractor diesel powered off-road equipment assigned to the contract shall be retrofitted using the phased in approach shown below. Equipment that is of a model year older than the year given for that equipment’s respective horsepower range shall be retrofitted:

Effective Dates	Horsepower Range	Model Year
June 1, 2010 ^{1/}	600-749	2002
	750 and up	2006
June 1, 2011 ^{2/}	100-299	2003
	300-599	2001
	600-749	2002
	750 and up	2006
June 1, 2012 ^{2/}	50-99	2004
	100-299	2003
	300-599	2001
	600-749	2002
	750 and up	2006

1/ Effective dates apply to Contractor diesel powered off-road equipment assigned to the contract.

2/ Effective dates apply to Contractor and subcontractor diesel powered off-road equipment assigned to the contract.

The retrofit emission control devices shall achieve a minimum PM emission reduction of 50 percent and shall be:

- a) Included on the U.S. Environmental Protection Agency (USEPA) *Verified Retrofit Technology List* (<http://www.epa.gov/cleandiesel/verification/verif-list.htm>), or verified by the California Air Resources Board (CARB) (<http://www.arb.ca.gov/diesel/verdev/vt/cvt.htm>); or
- b) Retrofitted with a non-verified diesel retrofit emission control device if verified retrofit emission control devices are not available for equipment proposed to be used on the project, and if the Contractor has obtained a performance certification from the retrofit

device manufacturer that the emission control device provides a minimum PM emission reduction of 50 percent.

Note: Large cranes (Crawler mounted cranes) which are responsible for critical lift operations are exempt from installing retrofit emission control devices if such devices adversely affect equipment operation.

Diesel powered off-road equipment with engine ratings of 50 hp and above, which are unable to be retrofitted with verified emission control devices or if performance certifications are not available which will achieve a minimum 50 percent PM reduction, may be granted a waiver by the Department if documentation is provided showing good faith efforts were made by the Contractor to retrofit the equipment.

Construction shall not proceed until the Contractor submits a certified list of the diesel powered off-road equipment that will be used, and as necessary, retrofitted with emission control devices. The list(s) shall include (1) the equipment number, type, make, Contractor/rental company name; and (2) the emission control devices make, model, USEPA or CARB verification number, or performance certification from the retrofit device manufacturer. Equipment reported as fitted with emissions control devices shall be made available to the Engineer for visual inspection of the device installation, prior to being used on the jobsite.

The Contractor shall submit an updated list of retrofitted off-road construction equipment as retrofitted equipment changes or comes on to the jobsite. The addition or deletion of any diesel powered equipment shall be included on the updated list.

If any diesel powered off-road equipment is found to be in non-compliance with any portion of this special provision, the Engineer will issue the Contractor a diesel retrofit deficiency deduction.

Any costs associated with retrofitting any diesel powered off-road equipment with emission control devices shall be considered as included in the contract unit prices bid for the various items of work involved and no additional compensation will be allowed. The Contractor's compliance with this notice and any associated regulations shall not be grounds for a claim.

Diesel Retrofit Deficiency Deduction

When the Engineer determines that a diesel retrofit deficiency exists, a daily monetary deduction will be imposed for each calendar day or fraction thereof the deficiency continues to exist. The calendar day(s) will begin when the time period for correction is exceeded and end with the Engineer's written acceptance of the correction. The daily monetary deduction will be \$1,000.00 for each deficiency identified.

The deficiency will be based on lack of diesel retrofit emissions control.

If a Contractor accumulates three diesel retrofit deficiency deductions for the same piece of equipment in a contract period, the Contractor will be shutdown until the deficiency is corrected.

Such a shutdown will not be grounds for any extension of the contract time, waiver of penalties, or be grounds for any claim.

80261

DISPOSAL FEES (BDE)

Effective: November 1, 2018

Replace Articles 109.04(b)(5) – 109.04(b)(8) of the Standard Specifications with the following:

- “(5) Disposal Fees. When the extra work performed includes paying for disposal fees at a clean construction and demolition debris facility, an uncontaminated soil fill operation or a landfill, the Contractor shall receive, as administrative costs, an amount equal to five percent of the first \$10,000 and one percent of any amount over \$10,000 of the total approved costs of such fees.
- (6) Miscellaneous. No additional allowance will be made for general superintendence, the use of small tools, or other costs for which no specific allowance is herein provided.
- (7) Statements. No payment will be made for work performed on a force account basis until the Contractor has furnished the Engineer with itemized statements of the cost of such force account work. Statements shall be accompanied and supported by invoices for all materials used and transportation charges. However, if materials used on the force account work are not specifically purchased for such work but are taken from the Contractor’s stock, then in lieu of the invoices, the Contractor shall furnish an affidavit certifying that such materials were taken from his/her stock, that the quantity claimed was actually used, and that the price and transportation claimed represent the actual cost to the Contractor.

Itemized statements at the cost of force account work shall be detailed as follows.

- a. Name, classification, date, daily hours, total hours, rate, and extension for each laborer and foreman. Payrolls shall be submitted to substantiate actual wages paid if so requested by the Engineer.
 - b. Designation, dates, daily hours, total hours, rental rate, and extension for each unit of machinery and equipment.
 - c. Quantities of materials, prices and extensions.
 - d. Transportation of materials.
 - e. Cost of property damage, liability and workmen’s compensation insurance premiums, unemployment insurance contributions, and social security tax.
- (8) Work Performed by an Approved Subcontractor. When extra work is performed by an approved subcontractor, the Contractor shall receive, as administrative costs, an amount equal to five percent of the total approved costs of such work with the minimum payment being \$100.

- (9) All statements of the cost of force account work shall be furnished to the Engineer not later than 60 days after receipt of the Central Bureau of Construction form "Extra Work Daily Report". If the statement is not received within the specified time frame, all demands for payment for the extra work are waived and the Department is released from any and all such demands. It is the responsibility of the Contractor to ensure that all statements are received within the specified time regardless of the manner or method of delivery."

80402

EQUIPMENT PARKING AND STORAGE (BDE)

Effective: November 1, 2017

Replace the first paragraph of Article 701.11 of the Standard Specifications with the following.

“701.11 Equipment Parking and Storage. During working hours, all vehicles and/or nonoperating equipment which are parked, two hours or less, shall be parked at least 8 ft (2.5 m) from the open traffic lane. For other periods of time during working and for all nonworking hours, all vehicles, materials, and equipment shall be parked or stored as follows.

- (a) When the project has adequate right-of-way, vehicles, materials, and equipment shall be located a minimum of 30 ft (9 m) from the pavement.
- (b) When adequate right-of-way does not exist, vehicles, materials, and equipment shall be located a minimum of 15 ft (4.5 m) from the edge of any pavement open to traffic.
- (c) Behind temporary concrete barrier, vehicles, materials, and equipment shall be located a minimum of 24 in. (600 mm) behind free standing barrier or a minimum of 6 in. (150 mm) behind barrier that is either pinned or restrained according to Article 704.04. The 24 in. or 6 in. measurement shall be from the base of the non-traffic side of the barrier.
- (d) Behind other man-made or natural barriers meeting the approval of the Engineer.”

80388

LIGHTS ON BARRICADES (BDE)

Effective: January 1, 2018

Revise Article 701.16 of the Standard Specifications to read:

“701.16 Lights. Lights shall be used on devices as required in the plans, the traffic control plan, and the following table.

Circumstance	Lights Required
Daylight operations	None
First two warning signs on each approach to the work involving a nighttime lane closure and “ROUGH GROOVED SURFACE” (W8-I107) signs	Flashing mono-directional lights
Devices delineating isolated obstacles, excavations, or hazards at night (Does not apply to patching)	Flashing bi-directional lights
Devices delineating obstacles, excavations, or hazards exceeding 100 ft (30 m) in length at night (Does not apply to widening)	Steady burn bi-directional lights
Channelizing devices for nighttime lane closures on two-lane roads	None
Channelizing devices for nighttime lane closures on multi-lane roads	None
Channelizing devices for nighttime lane closures on multi-lane roads separating opposing directions of traffic	None
Channelizing devices for nighttime along lane shifts on multilane roads	Steady burn mono-directional lights
Channelizing devices for night time along lane shifts on two lane roads	Steady burn bi-directional lights
Devices in nighttime lane closure tapers on Standards 701316 and 701321	Steady burn bi-directional lights
Devices in nighttime lane closure tapers	Steady burn mono-directional lights
Devices delineating a widening trench	None
Devices delineating patches at night on roadways with an ADT less than 25,000	None
Devices delineating patches at night on roadways with an ADT of 25,000 or more	None

Batteries for the lights shall be replaced on a group basis at such times as may be specified by the Engineer.”

Delete the fourth sentence of the first paragraph of Article 701.17(c)(2) of the Standard Specifications.

Revise the first paragraph of Article 603.07 of the Standard Specifications to read:

“603.07 Protection Under Traffic. After the casting has been adjusted and Class SI concrete has been placed, the work shall be protected by a barricade for at least 72 hours.”

80392

PAVEMENT MARKING REMOVAL (BDE)

Effective: July 1, 2016

Revise Article 783.02 of the Standard Specifications to read:

“783.02 Equipment. Equipment shall be according to the following.

Item	Article/Section
(a) Grinders (Note 1)	
(b) Water Blaster with Vacuum Recovery	1101.12

Note 1. Grinding equipment shall be approved by the Engineer.”

Revise the first paragraph of Article 783.03 of the Standard Specifications to read:

“783.03 Removal of Conflicting Markings. Existing pavement markings that conflict with revised traffic patterns shall be removed. If darkness or inclement weather prohibits the removal operations, such operations shall be resumed the next morning or when weather permits. In the event of removal equipment failure, such equipment shall be repaired, replaced, or leased so removal operations can be resumed within 24 hours.”

Revise the first and second sentences of the first paragraph of Article 783.03(a) of the Standard Specifications to read:

“The existing pavement markings shall be removed by the method specified and in a manner that does not materially damage the surface or texture of the pavement or surfacing. Small particles of tightly adhering existing markings may remain in place, if in the opinion of the Engineer, complete removal of the small particles will result in pavement surface damage.”

Revise the first paragraph of Article 783.04 of the Standard Specifications to read:

“783.04 Cleaning. The roadway surface shall be cleaned of debris or any other deleterious material by the use of compressed air or water blast.”

Revise the first paragraph of Article 783.06 of the Standard Specifications to read:

“783.06 Basis of Payment. This work will be paid for at the contract unit price per each for RAISED REFLECTIVE PAVEMENT MARKER REMOVAL, or at the contract unit price per square foot (square meter) for PAVEMENT MARKING REMOVAL – GRINDING and/or PAVEMENT MARKING REMOVAL – WATER BLASTING.”

Delete Article 1101.13 from the Standard Specifications.

PROGRESS PAYMENTS (BDE)

Effective: November 2, 2013

Revise Article 109.07(a) of the Standard Specifications to read:

“(a) Progress Payments. At least once each month, the Engineer will make a written estimate of the quantity of work performed in accordance with the contract, and the value thereof at the contract unit prices. The amount of the estimate approved as due for payment will be vouchered by the Department and presented to the State Comptroller for payment. No amount less than \$1000.00 will be approved for payment other than the final payment.

Progress payments may be reduced by liens filed pursuant to Section 23(c) of the Mechanics' Lien Act, 770 ILCS 60/23(c).

If a Contractor or subcontractor has defaulted on a loan issued under the Department's Disadvantaged Business Revolving Loan Program (20 ILCS 2705/2705-610), progress payments may be reduced pursuant to the terms of that loan agreement. In such cases, the amount of the estimate related to the work performed by the Contractor or subcontractor, in default of the loan agreement, will be offset, in whole or in part, and vouchered by the Department to the Working Capital Revolving Fund or designated escrow account. Payment for the work shall be considered as issued and received by the Contractor or subcontractor on the date of the offset voucher. Further, the amount of the offset voucher shall be a credit against the Department's obligation to pay the Contractor, the Contractor's obligation to pay the subcontractor, and the Contractor's or subcontractor's total loan indebtedness to the Department. The offset shall continue until such time as the entire loan indebtedness is satisfied. The Department will notify the Contractor and Fund Control Agent in a timely manner of such offset. The Contractor or subcontractor shall not be entitled to additional payment in consideration of the offset.

The failure to perform any requirement, obligation, or term of the contract by the Contractor shall be reason for withholding any progress payments until the Department determines that compliance has been achieved.”

TRAFFIC CONTROL DEVICES - CONES (BDE)

Effective: January 1, 2019

Revise Article 701.15(a) of the Standard Specifications to read:

“(a) Cones. Cones are used to channelize traffic. Cones used to channelize traffic at night shall be reflectorized; however, cones shall not be used in nighttime lane closure tapers or nighttime lane shifts.”

Revise Article 1106.02(b) of the Standard Specifications to read:

“(b) Cones. Cones shall be predominantly orange. Cones used at night that are 28 to 36 in. (700 to 900 mm) in height shall have two white circumferential stripes. If non-reflective spaces are left between the stripes, the spaces shall be no more than 2 in. (50mm) in width. Cones used at night that are taller than 36 in. (900 mm) shall have a minimum of two white and two fluorescent orange alternating, circumferential stripes with the top stripe being fluorescent orange. If non-reflective spaces are left between the stripes, the spaces shall be no more than 3 in. (75 mm) in width.

The minimum weights for the various cone heights shall be 4 lb for 18 in. (2 kg for 450 mm), 7 lb for 28 in. (3 kg for 700 mm), and 10 lb for 36 in. (5 kg for 900 mm) with a minimum of 60 percent of the total weight in the base. Cones taller than 36 in. shall be weighted per the manufacturer’s specifications such that they are not moved by wind or passing traffic.”

80409

Prevailing Wage Rates for Cook County (Updated 12/26/2018)

Trade Title	Region	Type	Class	Base Wage/reman Wa	OT M-F	OT Sa	OT Su	OT Hol	H/W	Pension	Vacation	Training	Fringe Benefit
ASBESTOS ABT-GEN	All	ALL		42.72	1.5	1.5	2	2	14.90	12.57	0.00	0.72	0.00
ASBESTOS ABT-MEC	All	BLD		37.88	1.5	1.5	2	2	12.92	11.82	0.00	0.72	0.00
BOILERMAKER	All	BLD		49.46	1.5	1.5	2	2	6.97	20.40	0.00	1.60	0.00
BRICK MASON	All	BLD		46.19	1.5	1.5	2	2	10.65	17.92	0.00	0.92	0.00
CARPENTER	All	ALL		47.35	1.5	1.5	2	2	11.79	20.41	0.00	0.63	0.00
CEMENT MASON	All	ALL		45.25	2	1.5	2	2	14.25	17.03	0.00	1.10	1.36
CERAMIC TILE FNLSHER	All	BLD		39.56	1.5	1.5	2	2	10.75	12.02	0.00	0.77	0.00
COMM. ELECT.	All	BLD		43.96	1.5	1.5	2	2	9.85	13.26	1.25	0.85	0.00
ELECTRIC PWR EQMT OP	All	ALL		51.90	1.5	1.5	2	2	12.04	17.18	0.00	3.23	0.00
ELECTRIC PWR GRNDMAN	All	ALL		40.48	1.5	1.5	2	2	9.39	13.40	0.00	2.51	0.00
ELECTRIC PWR LINEMAN	All	ALL		51.90	1.5	1.5	2	2	12.04	17.18	0.00	3.23	0.12
ELECTRICIAN	All	ALL		48.35	1.5	1.5	2	2	15.13	16.52	1.25	1.28	0.00
ELEVATOR CONSTRUCTOR	All	BLD		54.85	2	2	2	2	15.43	16.61	4.39	0.61	0.00
FENCE ERECTOR	All	ALL		40.88	1.5	1.5	2	1.5	13.59	14.76	0.00	0.65	0.00
GLAZIER	All	BLD		43.85	1.5	2	2	2	14.37	21.11	0.00	0.94	0.00
HT/FROST INSULATOR	All	BLD		50.50	1.5	1.5	2	2	12.92	13.16	0.00	0.87	0.00
IRON WORKER	All	ALL		48.33	2	2	2	2	14.15	23.28	0.00	0.35	0.00
LABORER	All	ALL		42.72	1.5	1.5	2	2	14.90	12.57	0.00	0.72	0.00
LATHER	All	ALL		47.35	1.5	1.5	2	2	11.79	20.41	0.00	0.63	0.00
MACHINIST	All	BLD		48.38	1.5	1.5	2	2	7.23	8.95	1.85	1.32	0.00
MARBLE FINISHERS	All	ALL		34.65	1.5	1.5	2	2	10.65	16.46	0.00	0.49	0.00
MARBLE MASON	All	BLD		45.43	1.5	1.5	2	2	10.65	17.39	0.00	0.61	0.00
MATERIAL TESTER I	All	ALL		32.72	1.5	1.5	2	2	14.90	12.57	0.00	0.72	0.00
MATERIALS TESTER II	All	ALL		40.37	1.5	1.5	2	2	18.55	8.85	0.00	1.10	1.50
MILLWRIGHT	All	ALL		46.35	1.5	1.5	2	2	13.05	18.87	0.00	0.00	0.00
OPERATING ENGINEER	All	BLD	1	51.10	2	2	2	2	19.65	15.10	2.00	1.40	0.00
OPERATING ENGINEER	All	BLD	2	49.80	2	2	2	2	19.65	15.10	2.00	1.40	0.00
OPERATING ENGINEER	All	BLD	3	47.25	2	2	2	2	19.65	15.10	2.00	1.40	0.00
OPERATING ENGINEER	All	BLD	4	45.50	2	2	2	2	19.65	15.10	2.00	1.40	0.00
OPERATING ENGINEER	All	BLD	5	54.85	2	2	2	2	19.65	15.10	2.00	1.40	0.00
OPERATING ENGINEER	All	BLD	6	53.10	2	2	2	2	0.00	0.00	0.00	0.00	36.45
OPERATING ENGINEER	All	BLD	7	54.10	2	2	2	2	19.65	15.10	2.00	1.40	0.00
OPERATING ENGINEER	All	FLT	1	57.05	1.5	1.5	2	2	18.80	14.35	2.00	1.30	0.00
OPERATING ENGINEER	All	FLT	2	55.55	1.5	1.5	2	2	18.80	14.35	2.00	1.30	0.00
OPERATING ENGINEER	All	FLT	3	49.45	1.5	1.5	2	2	18.80	14.35	2.00	1.30	0.00
OPERATING ENGINEER	All	FLT	4	41.10	1.5	1.5	2	2	18.80	14.35	2.00	1.30	0.00
OPERATING ENGINEER	All	FLT	5	58.55	1.5	1.5	2	2	18.80	14.35	2.00	1.30	0.00
OPERATING ENGINEER	All	FLT	6	38.00	1.5	1.5	2	2	18.80	14.35	2.00	1.30	0.00
OPERATING ENGINEER	All	HWY	1	49.30	1.5	1.5	2	2	19.65	15.10	2.00	1.40	1.13
OPERATING ENGINEER	All	HWY	2	48.75	1.5	1.5	2	2	19.65	15.10	2.00	1.40	0.00
OPERATING ENGINEER	All	HWY	3	46.70	1.5	1.5	2	2	19.65	15.10	2.00	1.40	0.00
OPERATING ENGINEER	All	HWY	4	51.20	1.5	1.5	2	2	18.00	21.28	1.50	0.15	0.00
OPERATING ENGINEER	All	HWY	5	44.10	1.5	1.5	2	2	19.65	15.10	2.00	1.40	0.00

Prevailing Wage Rates for Cook County (Updated 12/26/2018)

Trade Title	Region	Type	Class	Base Wage/reman Wa	OT M-F	OT Sa	OT Su	OT Hol	H/W	Pension	Vacation	Training	Fringe Benefit
OPERATING ENGINEER	All	HWY	6	52.30	1.5	1.5	2	2	19.65	15.10	2.00	1.40	0.00
OPERATING ENGINEER	All	HWY	7	50.30	1.5	1.5	2	2	19.65	15.10	2.00	1.40	0.00
ORNAMNTL IRON WORKER	All	ALL		48.05	2	2	2	2	14.09	20.59	0.00	1.25	0.38
PAINTER	All	ALL		46.55	1.5	1.5	1.5	2	11.81	11.94	0.00	1.87	0.00
PAINTER SIGNS	All	BLD		39.24	0.00	1.5	1.5	2	2.60	3.18	0.00	0.00	0.00
PILEDRIWER	All	ALL		47.35	1.5	1.5	2	2	11.79	20.41	0.00	0.63	0.00
PIPEFITTER	All	BLD		48.50	1.5	1.5	2	2	10.05	18.85	0.00	2.54	0.00
PLASTERER	All	BLD		43.25	1.5	1.5	2	2	14.25	16.69	0.00	1.35	0.00
PLUMBER	All	BLD		50.25	1.5	1.5	2	2	14.34	14.42	0.00	1.31	0.00
ROOFER	All	BLD		43.65	1.5	1.5	2	2	9.73	12.44	0.00	0.53	0.00
SHEETMETAL WORKER	All	BLD		44.25	1.5	1.5	2	2	11.35	24.68	0.00	1.68	0.00
SIGN HANGER	All	BLD		31.31	1.5	1.5	2	2	4.85	3.28	0.00	0.00	0.00
SPRINKLER FITTER	All	BLD		48.10	1.5	1.5	2	2	13.25	15.90	0.00	0.68	0.00
STEEL ERECTOR	ALL	ALL		42.07	2	2	2	2	13.45	19.59	0.00	0.35	
STONE MASON	All	BLD		46.19	1.5	1.5	2	2	10.65	17.92	0.00	0.92	0.00
TERRAZZO FINISHER	All	BLD		41.54	1.5	1.5	2	2	10.75	13.71	0.00	0.86	0.00
TERRAZZO MASON	All	BLD		45.38	1.5	1.5	2	2	10.75	15.17	0.00	0.89	0.00
TILE MASON	All	BLD		46.49	1.5	1.5	2	2	10.75	14.99	0.00	0.90	0.00
TRAFFIC SAFETY WRKR	All	HWY		37.00	1.5	1.5	2	2	8.90	9.27	0.00	0.50	0.00
TRUCK DRIVER	E	ALL	1	35.60	1.5	1.5	2	2	8.60	10.61	1.00	0.15	1.00
TRUCK DRIVER	E	ALL	2	36.70	1.5	1.5	2	2	9.68	13.25	0.00	0.15	0.00
TRUCK DRIVER	E	ALL	3	36.90	1.5	1.5	2	2	9.68	13.25	0.00	0.15	0.00
TRUCK DRIVER	E	ALL	4	37.10	1.5	1.5	2	2	9.68	13.25	0.00	0.15	0.00
TRUCK DRIVER	W	ALL	1	37.69	1.5	1.5	2	2	10.50	8.50	0.00	0.15	0.00
TRUCK DRIVER	W	ALL	2	36.13	1.5	1.5	2	2	18.85	8.85	0.00	2.60	0.00
TRUCK DRIVER	W	ALL	3	40.34	1.5	1.5	2	2	10.47	12.50	0.00	0.50	2.81
TRUCK DRIVER	W	ALL	4	38.16	1.5	1.5	2	2	8.90	11.16	0.00	0.50	0.00
TUCKPOINTER	All	BLD		46.00	1.5	1.5	2	2	8.34	16.81	0.00	0.93	0.00

Prevailing Wage Rates for Lake County (Updated 12/26/2018)

Trade Title	Region	Type	Class	Base Wage/reman Wa	OT M-F	OT Sa	OT Su	OT Hol	H/W	Pension	Vacation	Training	Fringe Benefit
ASBESTOS ABT-GEN	All	ALL		42.72	1.5	1.5	2	2	14.90	12.57	0.00	0.72	0.00
ASBESTOS ABT-MEC	All	BLD		37.88	1.5	1.5	2	2	12.92	11.82	0.00	0.72	0.00
BOILERMAKER	All	BLD		49.46	2	2	2	2	6.97	20.41	0.00	0.40	0.00
BRICK MASON	All	BLD		46.19	1.5	1.5	2	2	10.65	17.92	0.00	0.92	0.00
CARPENTER	All	ALL		47.35	1.5	1.5	2	2	11.79	20.41	0.00	0.63	0.00
CEMENT MASON	All	ALL		45.53	2	1.5	2	2	10.25	22.38	0.00	0.59	0.00
CERAMIC TILE FNShER	All	BLD		39.56	1.5	1.5	2	2	10.75	12.02	0.00	0.77	0.00
COMMUNICATION TECH	All	BLD		36.95	1.5	1.5	2	2	11.72	7.35	2.17	0.55	7.94
ELECTRIC PWR EQMT OP	All	ALL		42.59	1.5	1.5	2	2	5.75	13.21	0.00	0.75	0.00
ELECTRIC PWR EQMT OP	ALL	HWY		41.45	1.5	1.5	2	2	5.50	12.87	0.00	0.73	0.00
ELECTRIC PWR GRNDMAN	All	ALL		32.86	1.5	1.5	2	2	5.75	10.20	0.00	0.58	0.00
ELECTRIC PWR GRNDMAN	ALL	HWY		32.00	1.5	1.5	2	2	5.50	9.92	0.00	0.66	0.00
ELECTRIC PWR LINEMAN	All	ALL		51.06	1.5	1.5	2	2	5.75	15.85	0.00	0.90	0.00
ELECTRIC PWR LINEMAN	ALL	HWY		49.67	1.5	1.5	2	2	5.50	15.40	0.00	0.88	0.00
ELECTRIC PWR TRK DRV	All	ALL		34.03	1.5	1.5	2	2	5.75	10.55	0.00	0.60	0.00
ELECTRIC PWR TRK DRV	ALL	HWY		33.14	1.5	1.5	2	2	5.50	10.29	0.00	0.59	0.00
ELECTRICIAN	All	BLD		40.00	1.5	1.5	2	2	14.10	20.29	6.00	0.65	0.00
ELEVATOR CONSTRUCTOR	All	BLD		54.85	1.5	2	2	2	15.43	9.71	4.39	0.61	6.90
FENCE ERECTOR	All	ALL		39.58	1.5	1.5	2	2	13.40	13.90	0.00	0.40	0.00
GLAZIER	All	BLD		43.85	1.5	2	2	2	14.17	21.11	0.00	0.94	0.00
HT/FROST INSULATOR	All	BLD		50.50	1.5	1.5	2	2	12.92	13.16	0.00	0.72	0.00
IRON WORKER	All	ALL		48.83	2	2	2	2	14.15	23.28	4.00	0.35	0.00
LABORER	All	ALL		42.72	1.5	1.5	2	2	13.77	13.70	0.00	0.96	0.00
LATHER	All	ALL		47.35	1.5	1.5	2	2	11.79	20.41	0.00	0.63	0.00
MACHINIST	All	BLD		48.38	1.5	1.5	2	2	7.23	8.95	1.85	1.47	0.00
MARBLE FINISHERS	All	ALL		34.65	1.5	1.5	2	2	10.65	16.46	0.00	0.49	0.00
MARBLE MASON	All	BLD		45.43	1.5	1.5	2	2	10.65	17.39	0.00	0.61	0.00
MATERIAL TESTER I	All	ALL		32.72	1.5	1.5	2	2	14.90	12.57	0.00	0.72	0.00
MATERIALS TESTER II	All	ALL		37.72	1.5	1.5	2	2	14.90	12.57	0.00	0.72	0.00
MILLWRIGHT	All	ALL		47.35	1.5	1.5	2	2	11.79	20.41	0.00	0.63	0.00
OPERATING ENGINEER	All	BLD	1	50.10	1.5	1.5	2	2	18.80	14.35	2.00	1.30	0.00
OPERATING ENGINEER	All	BLD	2	48.80	1.5	1.5	2	2	18.80	14.35	2.00	1.30	0.00
OPERATING ENGINEER	All	BLD	3	47.25	2	2	2	2	19.65	15.10	2.00	1.40	0.00
OPERATING ENGINEER	All	BLD	4	45.50	2	2	2	2	19.65	15.10	2.00	1.40	0.00
OPERATING ENGINEER	All	BLD	5	54.85	2	2	2	2	19.65	15.10	2.00	1.40	0.00
OPERATING ENGINEER	All	BLD	6	52.10	2	2	2	2	19.65	15.10	2.00	1.40	0.00
OPERATING ENGINEER	All	BLD	7	53.10	2	2	2	2	0.00	0.00	0.00	0.00	36.45
OPERATING ENGINEER	All	FLT	1	57.05	1.5	1.5	2	2	18.80	14.35	2.00	1.30	0.00
OPERATING ENGINEER	All	FLT	2	55.55	1.5	1.5	2	2	18.80	14.35	2.00	1.30	0.00
OPERATING ENGINEER	All	FLT	3	49.45	1.5	1.5	2	2	18.80	14.35	2.00	1.30	0.00
OPERATING ENGINEER	All	FLT	4	40.25	1.5	1.5	1.5	1.5	18.05	13.60	1.90	1.30	0.00
OPERATING ENGINEER	All	FLT	5	58.55	1.5	1.5	2	2	18.80	14.35	2.00	1.30	0.00
OPERATING ENGINEER	All	FLT	6	38.00	1.5	1.5	2	2	18.80	14.35	2.00	1.30	0.00

Prevailing Wage Rates for Lake County (Updated 12/26/2018)

Trade Title	Region	Type	Class	Base Wage	Wage	OT M-F	OT Sa	OT Su	OT Hol	H/W	Pension	Vacation	Training	Fringe Benefit
OPERATING ENGINEER	All	HWY	1	49.30	53.30	1.5	1.5	2	2	19.65	15.10	2.00	1.40	0.00
OPERATING ENGINEER	All	HWY	2	48.75	53.30	1.5	1.5	2	2	19.65	15.10	2.00	1.40	0.00
OPERATING ENGINEER	All	HWY	3	46.70	53.30	1.5	1.5	2	2	19.65	15.10	2.00	1.40	0.00
OPERATING ENGINEER	All	HWY	4	44.30		1.5	1.5	2	2	18.80	14.35	2.00	1.30	0.00
OPERATING ENGINEER	All	HWY	5	43.10		1.5	1.5	2	2	7.48	4.50	1.50	0.10	22.87
OPERATING ENGINEER	All	HWY	6	52.30	53.30	1.5	1.5	2	2	19.65	15.10	2.00	1.40	0.00
OPERATING ENGINEER	All	HWY	7	50.30	53.30	1.5	1.5	2	2	19.65	15.10	2.00	1.40	0.00
ORNAMNTL IRON WORKER	All	ALL		48.05	50.55	2	2	2	2	14.09	20.59	0.00	1.25	0.00
PAINTER	All	ALL		46.55	52.36	1.5	1.5	1.5	2	11.81	11.94	0.00	1.87	0.00
PAINTER SIGNS	All	BLD		38.20	43.25	1.5	1.5	2	2	2.60	3.25	0.00	0.00	0.00
PILEDRIWER	All	ALL		47.35	49.35	1.5	1.5	2	2	11.79	20.41	0.00	0.63	0.00
PIPEFITTER	All	BLD		48.50	51.50	1.5	1.5	2	2	10.05	18.85	0.00	2.54	0.00
PLASTERER	All	BLD		45.40	47.40	2	1.5	2	2	10.25	22.68	0.00	0.50	0.00
PLUMBER	All	BLD		50.25	53.25	1.5	1.5	2	2	14.35	14.42	0.00	1.31	0.00
ROOFER	All	BLD		43.65	47.65	1.5	1.5	2	2	9.73	12.44	0.00	0.53	0.00
SHEETMETAL WORKER	All	BLD		44.25		1.5	1.5	2	2	11.35	24.68	0.00	0.81	0.00
SIGN HANGER	All	BLD		45.75	47.25	1.5	1.5	2	2	5.87	11.26	0.00	0.49	3.20
SPRINKLER FITTER	All	BLD		48.10	50.60	1.5	1.5	2	2	12.75	13.65	0.00	0.55	0.00
STEEL ERECTOR	ALL	ALL		42.07	44.07	2	2	2	2	13.45	19.59	0.00	0.35	
STONE MASON	All	BLD		46.19	50.81	1.5	1.5	2	2	10.65	17.92	0.00	0.92	0.00
TERRAZZO FINISHER	All	BLD		41.54	44.54	1.5	1.5	2	2	10.75	13.71	0.00	0.86	0.00
TERRAZZO MASON	All	BLD		45.38	48.88	1.5	1.5	2	2	10.75	15.17	0.00	0.89	0.00
TILE MASON	All	BLD		46.49	50.49	1.5	1.5	2	2	10.75	14.99	0.00	0.90	0.00
TRAFFIC SAFETY WRKR	All	HWY		36.00	37.60	1.5	1.5	2	1.5	7.05	8.00	1.70	1.20	0.00
TRUCK DRIVER	All	ALL	1	37.05		1.5	1.5	2	2	8.60	10.61	1.00	0.15	0.00
TRUCK DRIVER	All	ALL	2	37.20		1.5	1.5	2	2	9.50	7.50	0.00	0.15	0.00
TRUCK DRIVER	All	ALL	3	40.34		1.5	1.5	2	2	10.47	12.50	0.00	0.50	2.81
TRUCK DRIVER	All	ALL	4	37.10		1.5	1.5	2	2	9.68	13.25	0.00	0.20	0.00
TUCKPOINTER	All	BLD		46.00	47.00	1.5	1.5	2	2	8.34	16.81	0.00	0.93	0.00

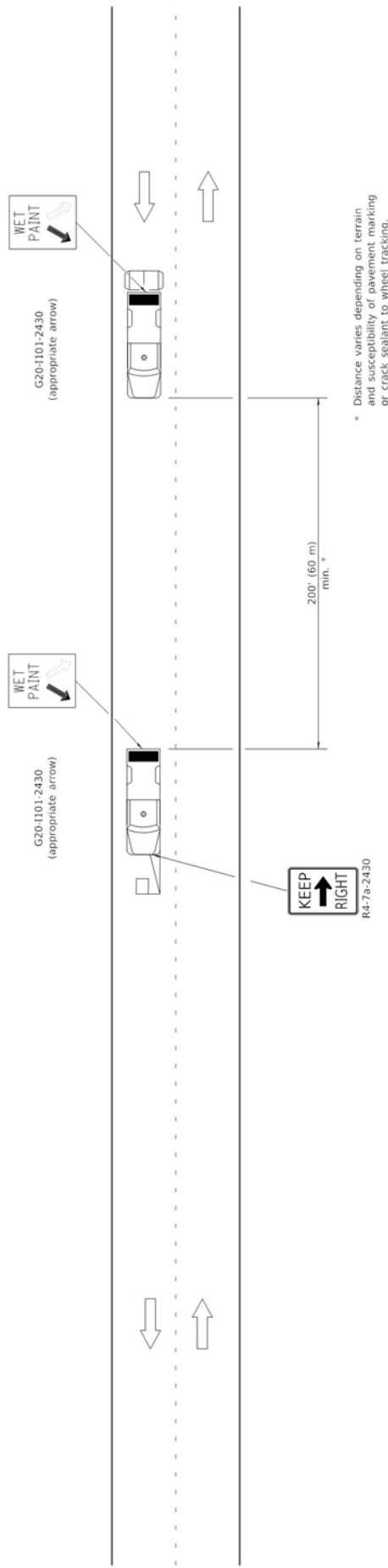

* Distance varies depending on terrain and susceptibility of pavement marking or crack sealant to wheel tracking.

TYPICAL APPLICATIONS

- Landscape work
- Utility work
- Pavement marking
- Weed spraying
- Roadometer measurements
- Debris Cleanup
- Crack pouring

SYMBOLS

- Arrow board (Hazard Mode only)
- Truck with headlights, emergency flashers and flashing amber light. (Visible from all directions)
- 18x18 (450x450) min. orange flag (use when guide wheel is used)
- Truck mounted attenuator

GENERAL NOTES

This Standard is used where any vehicle, equipment, workers or their activities will require a continuous moving operation where the average speed is greater than 3 mph (5 km/h).

For shoulder operations not encroaching on the pavement, use DETAIL A, Standard 701426.

All dimensions are in inches (millimeters) unless otherwise shown.

LANE CLOSURE 2L, 2W MOVING OPERATIONS- DAY ONLY	
DATE	REVISIONS
1-1-09	Switched units to English (metric). Omitted Pass With Care sign.
1-1-00	Elim. speed restrictions in Standard title.

STANDARD 701311-03

Illinois Department of Transportation
 PASSED January 1, 2009
 ENGINEER OF OPERATIONS
 APPROVED January 1, 2009
 ENGINEER OF DESIGN AND ENVIRONMENT

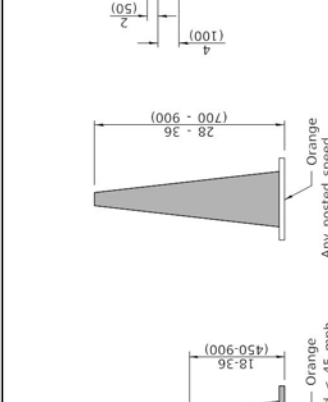
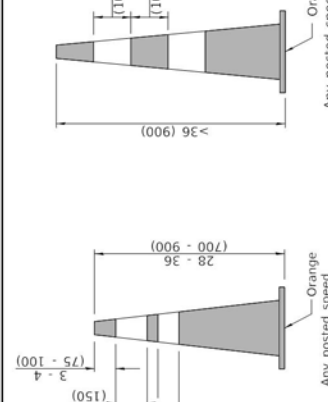
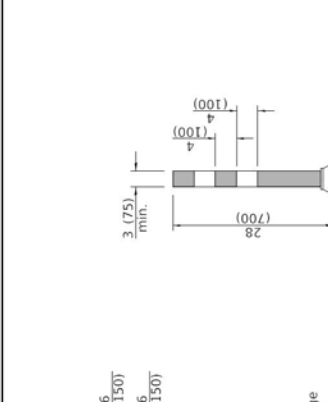
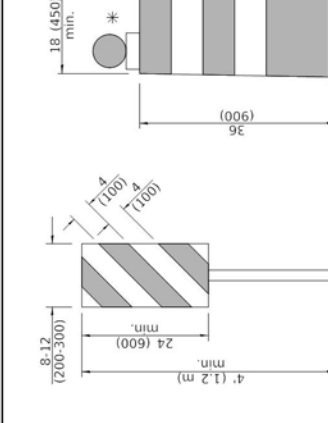

DAYTIME USE
Orange
Posted speed < 45 mph

DAY OR NIGHTTIME USE
Orange
Any posted speed

CONES

TUBULAR MARKER

**VERTICAL PANEL
POST MOUNTED**

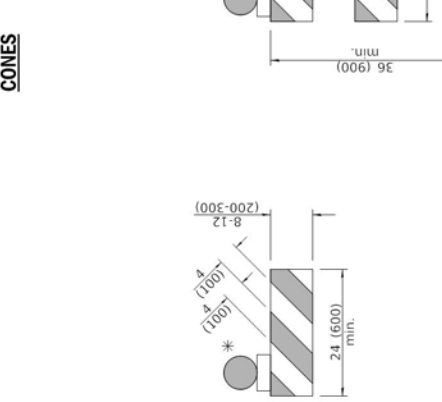
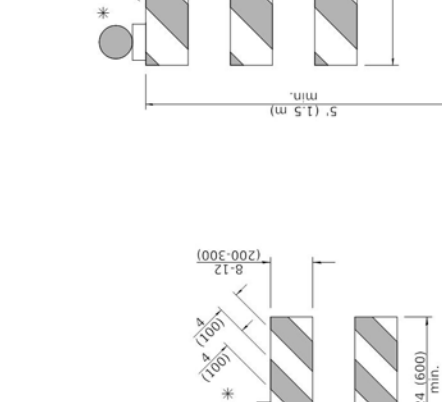
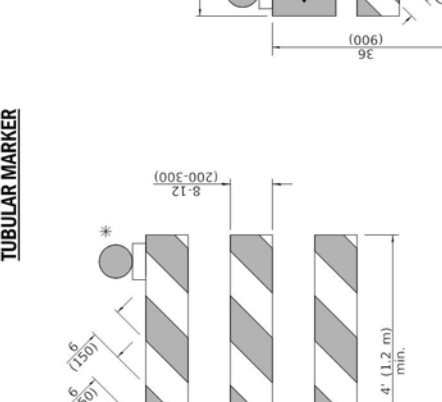
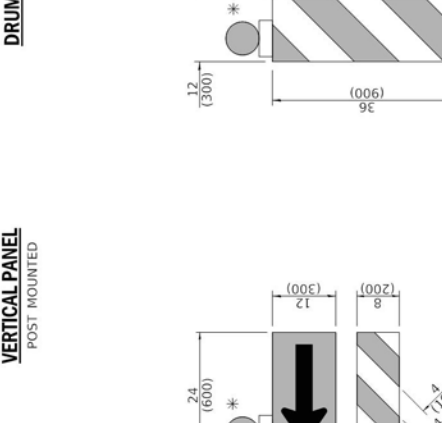

DRUM

VERTICAL BARRICADE

**DIRECTION INDICATOR
BARRICADE**

TYPE I BARRICADE

TYPE II BARRICADE

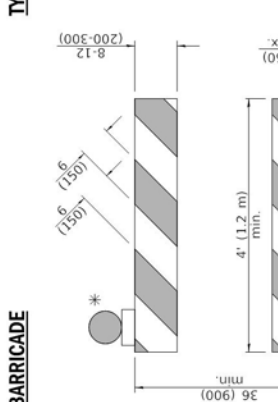

TYPE III BARRICADE

**DETECTABLE PEDESTRIAN
CHANNELIZING BARRICADE**

**DETECTABLE PEDESTRIAN
CHANNELIZING BARRICADE**

**DETECTABLE PEDESTRIAN
CHANNELIZING BARRICADE**

**DETECTABLE PEDESTRIAN
CHANNELIZING BARRICADE**

* Warning lights (if required)

GENERAL NOTES

All heights shown shall be measured above the pavement surface.

All dimensions are in inches (millimeters) unless otherwise shown.

Revised cone usage and added cones >36" (900 m) height.

Revised END WORK ZONE SPEED LIMIT sign from orange to white background.

DATE	REVISIONS
1-1-19	Revised cone usage and added cones >36" (900 m) height.
1-1-18	Revised END WORK ZONE SPEED LIMIT sign from orange to white background.

TRAFFIC CONTROL DEVICES

(Sheet 1 of 3)

STANDARD 701901-08

Illinois Department of Transportation
 APPROVED January 1, 2019
 ENGINEER OF SAFETY PROG. AND ENGINEERING
 APPROVED January 1, 2019
 ENGINEER OF DESIGN AND ENVIRONMENT

ISSUED 1-1-13

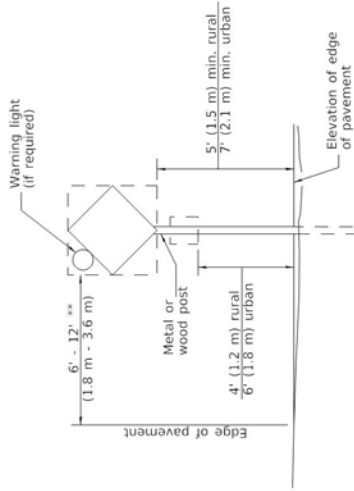

5' (1.5 m) min. embedment

POST MOUNTED SIGNS

** When curb or paved shoulder are present this dimension shall be 24 (600) to the face of curb or 6' (1.8 m) to the outside edge of the paved shoulder.

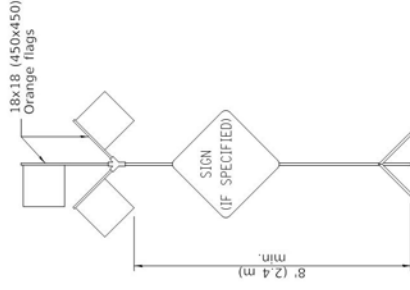

HIGH LEVEL WARNING DEVICE

SIGNS ON TEMPORARY SUPPORTS

*** When work operations exceed four days, this dimension shall be 24 (600) to the face of curb or 6' (1.8 m) to the outside edge of the paved shoulder. The height shall be sufficient to be seen completely above the devices.

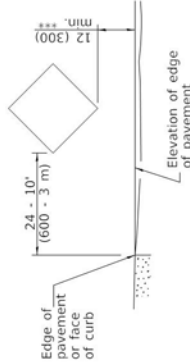

ROAD CONSTRUCTION NEXT X MILES
G20-1104(0)-6036

END CONSTRUCTION
G20-1105(0)-6024

This signing is required for all projects 2 miles (3200 m) or more in length.

ROAD CONSTRUCTION NEXT X MILES sign shall be placed 500' (150 m) in advance of project limits.

END CONSTRUCTION sign shall be erected at the end of the job unless another job is within 2 miles (3200 m).

Dual sign displays shall be utilized on multi-lane highways.

WORK LIMIT SIGNING

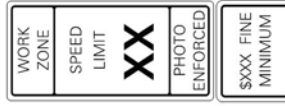

W21-1115(0)-3618

R2-1-3648

R10-1108p-3618 ****

R2-1106p-3618

Sign assembly as shown on Standards or as allowed by District Operations.



G20-1103-6036

This sign shall be used when the above sign assembly is used.

HIGHWAY CONSTRUCTION SPEED ZONE SIGNS

**** R10-1108p shall only be used along roadways under the jurisdiction of the State.

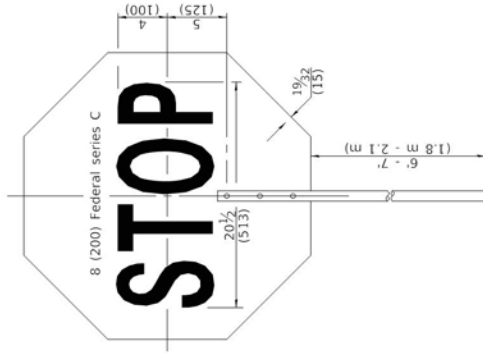

W12-1103-4848

WIDTH RESTRICTION SIGN

XX-XX* width and X miles are variable.

Illinois Department of Transportation

APPROVED January 1, 2019
 ENGINEER OF SAFETY PROG. AND ENGINEERING
 APPROVED January 1, 2019
 ENGINEER OF DESIGN AND ENVIRONMENT

FLAGGER TRAFFIC CONTROL SIGN

REVERSE SIDE

FRONT SIDE

TRAFFIC CONTROL DEVICES

(Sheet 2 of 3)

STANDARD 701901-08

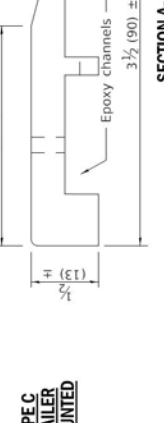
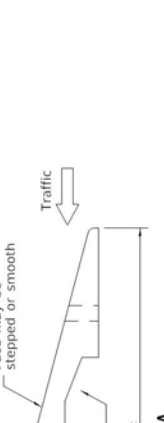
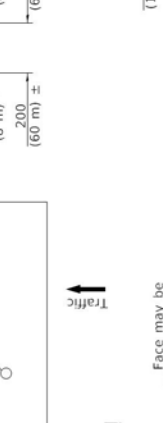
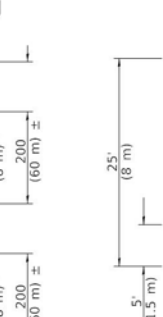
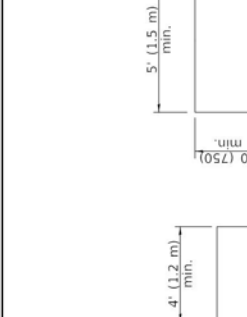
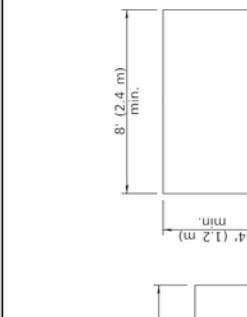
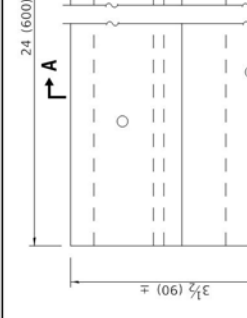
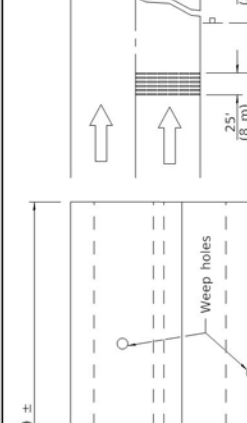
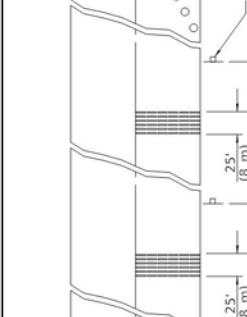

**TYPE A
ROOF
MOUNTED**

**TYPE B
ROOF OR TRAILER
MOUNTED**

**TYPE C
TRAILER
MOUNTED**

ARROW BOARDS

TEMPORARY RUMBLE STRIPS

TYPICAL INSTALLATION

**TYPICAL APPLICATIONS OF
TYPE III BARRICADES CLOSING A ROAD**

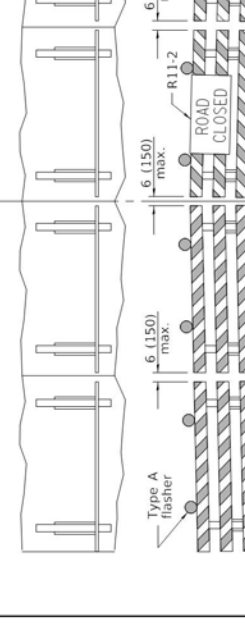
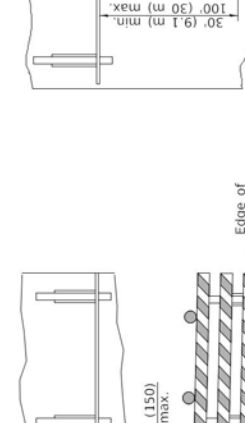
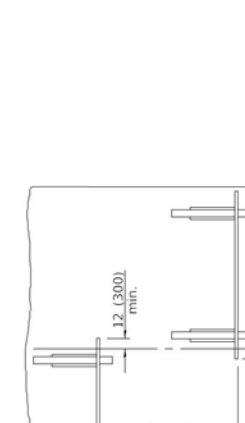

ROAD CLOSED TO ALL TRAFFIC

ROAD CLOSED TO THRU TRAFFIC

ROAD CLOSED TO THRU TRAFFIC

ROAD CLOSED TO THRU TRAFFIC

ReflectORIZED striping may be omitted on the back side of the barricades. If a Type III barricade with reflectORIZED striping is used, MCHRP 350 is not available, the sign may be mounted on an MCHRP 350 temporary sign support directly in front of the barricade.

ReflectORIZED striping shall appear on both sides of the barricades. If a Type III barricade with reflectORIZED striping is used, MCHRP 350 is not available, the signs may be mounted on MCHRP 350 temporary sign supports directly in front of the barricade.

ReflectORIZED striping shall appear on both sides of the barricades. If a Type III barricade with reflectORIZED striping is used, MCHRP 350 is not available, the signs may be mounted on MCHRP 350 temporary sign supports directly in front of the barricade.

ReflectORIZED striping shall appear on both sides of the barricades. If a Type III barricade with reflectORIZED striping is used, MCHRP 350 is not available, the signs may be mounted on MCHRP 350 temporary sign supports directly in front of the barricade.

TRAFFIC CONTROL DEVICES
(Sheet 3 of 3)

STANDARD 701901-08

Illinois Department of Transportation
APPROVED January 1, 2019
ENGINEER OF SAFETY PROG. AND ENGINEERING
APPROVED January 1, 2019
ENGINEER OF DESIGN AND ENVIRONMENT

ISSUED 1-1-13

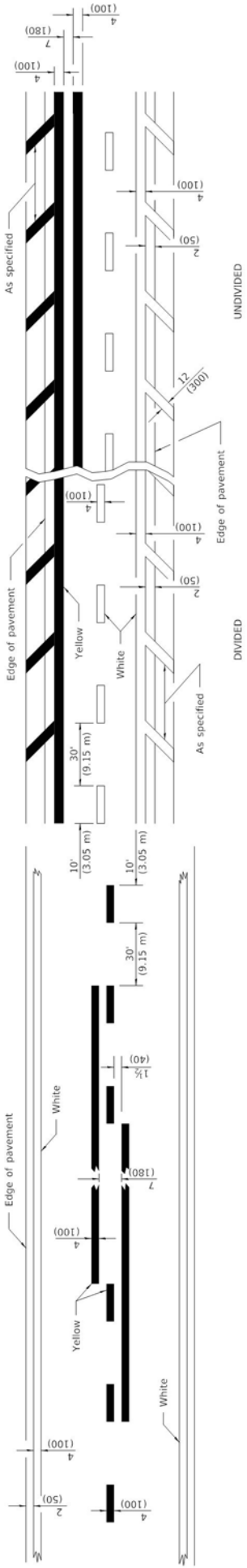

2 LANE

DIVIDED

MULTI LANE

LANE AND EDGE LINES

Approximately 15' (4.5 m) from nearest rail or 8' (2.4 m) back from gate, if present. Stop line placed perpendicular to center line.

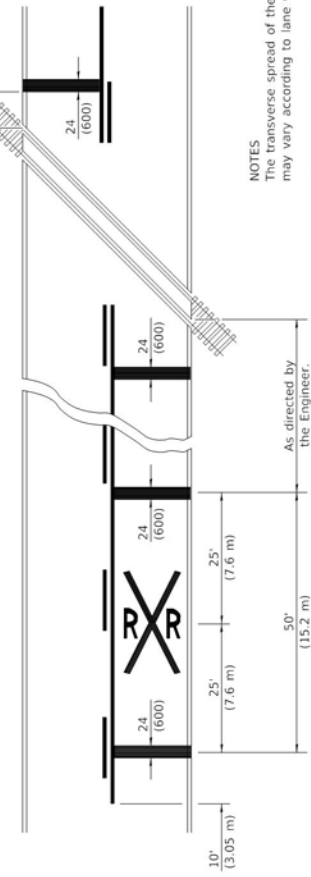

NOTES

The transverse spread of the "X" may vary according to lane width.
 On multi-lane roads, the stop lines shall extend across all approach lanes and separate RRR symbols shall be placed adjacent to each other in each lane.
 When the pavement marking symbol is used, a portion of the symbol should be located directly adjacent to the Advance Warning Sign (W10-1) as placed by Table 2C-4, Condition B of the MUTCD.

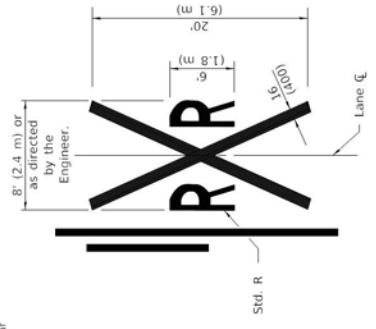

PAVEMENT MARKINGS AT RAILROAD-HIGHWAY GRADE CROSSING

TYPICAL PAVEMENT MARKINGS

DATE	REVISIONS
1-1-15	Added symbols. Revised bike symbol. Revised note for stop line at RR crossing.
1-1-14	Added bike symbol. Renamed 'LANE DROP ARROW' detail to 'LANE-REDUCTION ARROW'.

All dimensions are in inches (millimeters) unless otherwise shown.

STANDARD 780001-05

(Sheet 1 of 3)

Illinois Department of Transportation
 PASSED January 1, 2015
 ENGINEER OF OPERATIONS
 APPROVED January 1, 2015
 ENGINEER OF DESIGN AND ENVIRONMENT

A B C D E F G H I J
 K L M N O P Q R S
 T U V W X Y Z 1 2
 3 4 5 6 7 8 9 0

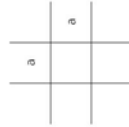
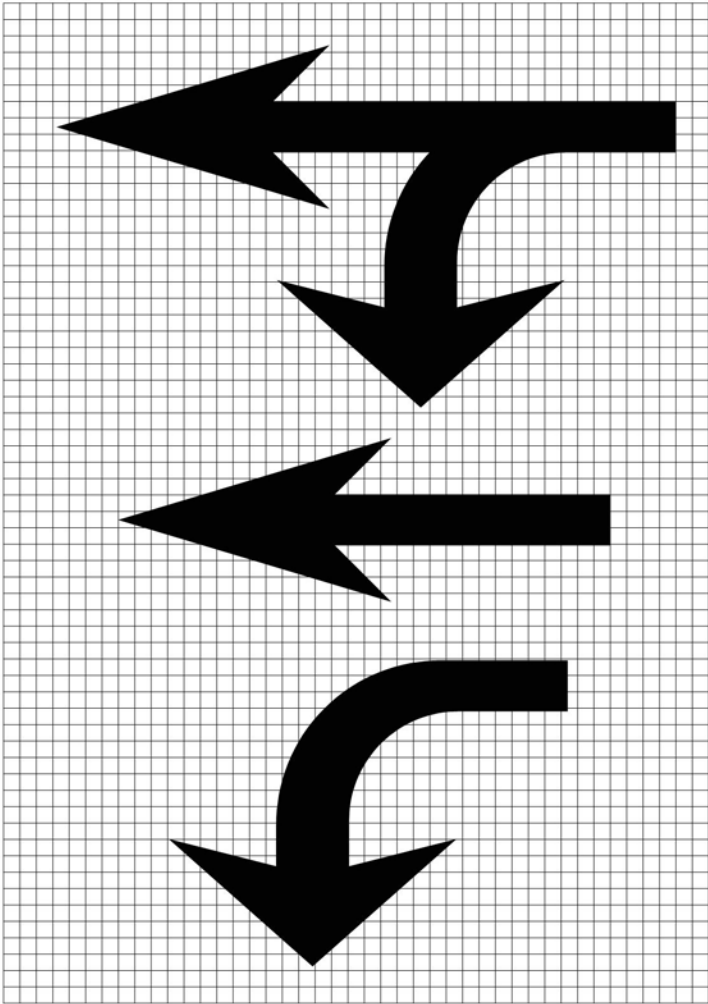

The space between adjacent letters or numerals should be approximately 3/8" (75) for 6" (1.8 m) legend and 4/100" for 8" (2.4 m) legend.

Legend Height	Arrow Size	a
6" (1.8 m)	Small	2.9 (74)
8" (2.4 m)	Large	3.8 (96)

LETTER AND ARROW GRID SCALE

Illinois Department of Transportation
 PASSED January 1, 2015
 APPROVED *James J. [Signature]*
 ENGINEER OF OPERATIONS
 APPROVED January 1, 2015
 ENGINEER OF DESIGN AND ENVIRONMENT

TYPICAL PAVEMENT MARKINGS
 (Sheet 2 of 3)
 STANDARD 780001-05

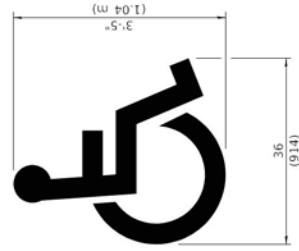

INTERNATIONAL SYMBOL OF ACCESSIBILITY



20' (6 m): urban
50' (15 m): rural
(Between arrow
and word or
between words)



6' (1.8 m): urban
8' (2.4 m): rural

WORD AND ARROW LAYOUT

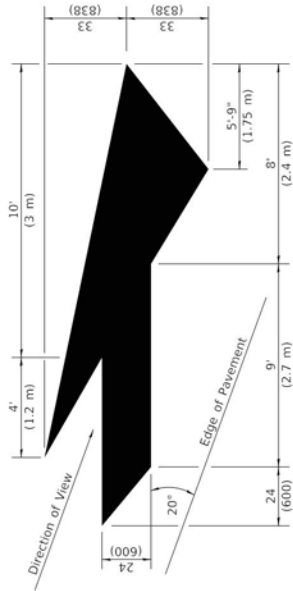

LANE-REDUCTION ARROW

Right lane-reduction arrow shown.
Use mirror image for left lane.

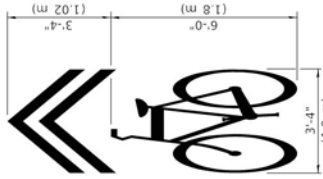

SHARED LANE SYMBOL

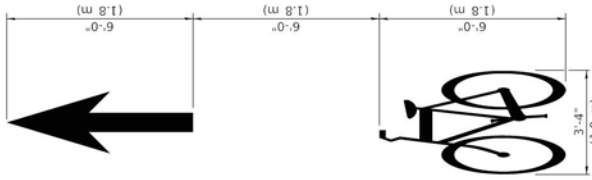

BIKE SYMBOL
(Arrow is optional.)

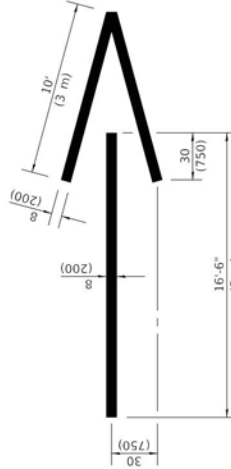

WRONG WAY ARROW

Illinois Department of Transportation

PASSED January 1, 2015
ENGINEER OF OPERATIONS
APPROVED January 1, 2015
ENGINEER OF DESIGN AND ENVIRONMENT

ISSUED 1-1-97

TYPICAL PAVEMENT MARKINGS

(Sheet 3 of 3)

STANDARD 780001-05

DFTY	SPEED LIMIT
345	30
425	35
500	40
580	45
665	50
750	55

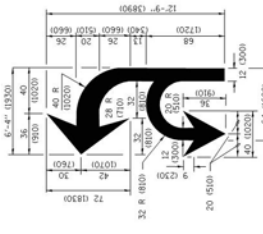

COMBINATION LEFT AND U-TURN

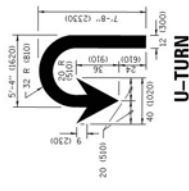

U-TURN

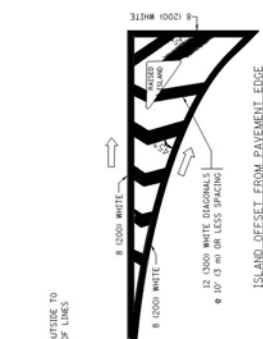

ISLAND OFFSET FROM PAVEMENT EDGE

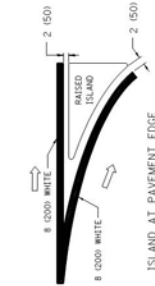

TYPICAL ISLAND MARKING

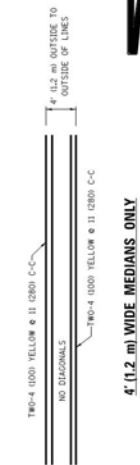

4' (1.2 m) WIDE MEDIANS ONLY

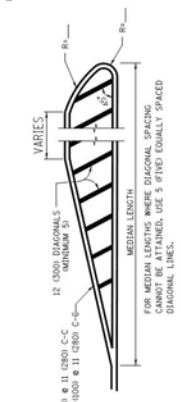

MEDIANS OVER 4' (1.2 m) WIDE

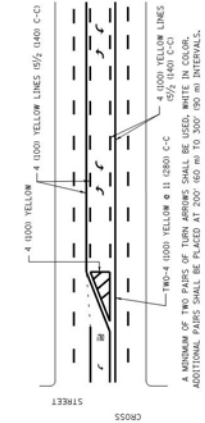

MULTI-LANE UNDIVIDED

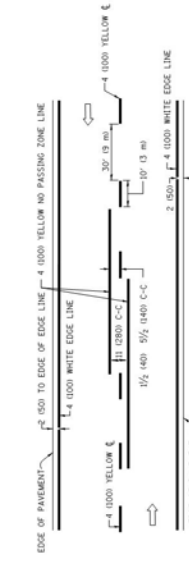

2-LANE ROADWAY

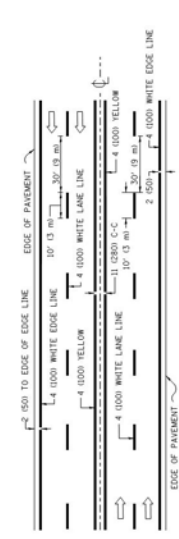

MULTI-LANE DIVIDED WITH MEDIAN

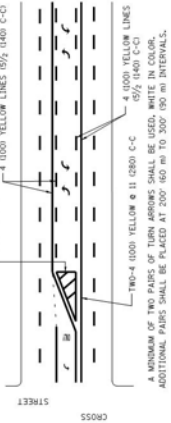

MEDIAN WITH TWO-WAY LEFT TURN LANE

TYPICAL PAINTED MEDIAN MARKING

TYPICAL LANE AND EDGE LINE MARKING

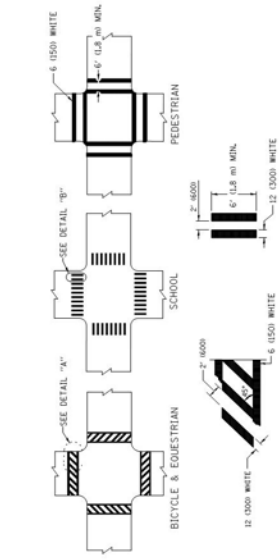

TYPICAL CROSSWALK MARKING

MARKINGS SHALL BE INSTALLED PARALLEL TO THE CENTERLINE OF THE ROAD WHICH IT CROSSES

LANE REDUCTION TRANSITION

*LANE REDUCTION ARROWS REQUIRED AT SPEEDS OF 45 MPH OR GREATER OR WHEN SPECIFIED IN PLANS.

TYPE OF MARKING	WIDTH OF LINE	PATTERN	COLOR	SPACING / REMARKS
CENTERLINE ON 2 LANE PAVEMENT	4 1000	SKIP-DASH	YELLOW	10' (3 m) LINE WITH 30' (9 m) SPACE
CENTERLINE ON MULTI-LANE UNDIVIDED PAVEMENT	2 4 1000	SOLID	YELLOW	11 0200 C-C
NO PASSING ZONE LINES FOR BOTH DIRECTIONS	4 1000	SOLID	YELLOW	51/2 1400 C-C FROM SKIP-DASH CENTERLINE OMIT SKIP-DASH CENTERLINE BETWEEN
LANE LINES	4 1000	SKIP-DASH	WHITE	10' (3 m) LINE WITH 30' (9 m) SPACE
DOTTED LINES EXTENSIONS OF CENTER, LANE OR TURN LANE MARKINGS	4 1000	SKIP-DASH	WHITE	2' (600 mm) LINE WITH 6' (1.8 m) SPACE
EDGE LINES	4 1000	SOLID	WHITE	OUTLINE MEDIANS IN YELLOW
TURN LANE MARKINGS	6 1000 LINES FULL SYMBOLS (R, L, U)	SOLID	WHITE	SEE TYPICAL TURN LANE MARKING DETAIL
TWO WAY LEFT TURN MARKING	2 4 1000 EACH DIRECTION	SKIP-DASH IN PAVED	YELLOW	10' (3 m) LINE WITH 30' (9 m) SPACE FOR LANE AND 30' (9 m) SPACE BETWEEN SOLID MARKING DETAIL
CROSSWALK LINES (PEDESTRIAN AND BICYCLE & EQUESTRIAN)	2 4 6 1000	SOLID	WHITE	NOT LESS THAN 6' (1.8 m) APART SEE TYPICAL CROSSWALK MARKING DETAILS.
STOP LINES	24 6000	SOLID	WHITE	PARALLEL TO CURB OR FACE OF BUILDING POSSIBLE PARALLEL TO CROSSWALK CENTERLINE. MARK
PAINTED MEDIANS	2 4 1 1000 WITH 12 0000 DIAGONALS USED FOR 4' (1.2 m) WIDE MEDIANS	SOLID	YELLOW	SEE TYPICAL PAINTED MEDIAN MARKING.
EDGE MARKING AND CHANNELLING LINES	24 6000 TRANSVERSE DIAGONALS @ 45°	SOLID	WHITE	DIAGONALS: 12' (3.6 m) C-C LESS THAN 30MPH (50 km/h) 30' (9 m) C-C COVER 40MPH (70 km/h) 30' (9 m) C-C COVER 40MPH (70 km/h) SEE STATE STANDARD 780001
RAILROAD CROSSING	24 6000 TRANSVERSE LINES - 98" (2.5 m) 6001 LINE FOR "X"	SOLID	WHITE	AREA OF "X" SHALL BE 15' (4.5 m) EACH "X" - 15' (4.5 m) C-C, 15' (4.5 m) C-C
SHOULDER DIAGONALS (REQUIRED FOR SHOULDER 2' B')	12 1000 @ 45°	SOLID	WHITE	50' (15 m) C-C LESS THAN 30MPH (50 km/h) 150' (45 m) C-C COVER 40MPH (70 km/h)
U TURN ARROW	SEE DETAIL	SOLID	WHITE	30x3 5F
2 ARROW COMBINATION LEFT AND U TURN	SEE DETAIL	SOLID	WHITE	30x4 5F

FOR FURTHER DETAILS ON PAVEMENT MARKING REFER TO STANDARD SPECIFICATIONS FOR ROAD AND BRIDGE CONSTRUCTION AND STATE STANDARD 780001.

All dimensions are in inches unless otherwise specified unless otherwise shown.

FILE NAME + I:\proj	DESIGNED - EVERS	DISTRICT ONE	SECTION	COUNTY	SHEET NO.
PROJECT NO. 02-11-13	DRAWN -	TYPICAL PAVEMENT MARKINGS	TC-13	ILLINOIS	CONTRACT NO.
REVISION - C. JUCIUS 07-01-13	CHECKED -	SCALE NONE	SHEET 1 OF 1	SHEETS STA.	TO STA.
REVISION - C. JUCIUS 12-21-15	DATE - 03-19-90				
REVISION - C. JUCIUS 04-12-16					