

CONTRACT, LEASE, AGREEMENT CONTROL FORM

Date: 11/18/2020

Contract/Lease Control #: C21-3015-FM

Procurement#: ITB PW 49-20

Contract/Lease Type: AGREEMENT

Award To/Lessee: DECKS N SUCH MARINE, INC.

Owner/Lessor: OKALOOSA COUNTY

Effective Date: 11/17/2020

Expiration Date: 180 DAYS FROM NTP

Description of: LONGWOOD/POQUITO BAYOU PARK EXTENSION

Department: FM

Department Monitor: HENDRICKS

Monitor's Telephone #: 850-689-5970

Monitor's FAX # or E-mail: BHENDRICKS@MYOKALOOSA.COM

Closed:

Cc: BCC RECORDS

**STATE OF FLORIDA
COUNTY OF WALTON**

PERMIT # _____

NOTICE OF COMMENCEMENT

The undersigned hereby informs all concerned that improvements will be made to certain real property, and in accordance with Section 713.13 of the Florida Statutes, the following information is stated in this NOTICE OF COMMENCEMENT:

Legal description of property to be improved Parcel ID # 31-1S-23-0120-0000-PARK
Longwood/Poquito Bayou Park

Street address (if any) 4 Bay Street, Shalimar 32579

General description of improvements Remove a 54sq.ft.terminal platform and add a dock extension to an existing public park dock with a wave attenuation fence for a total of 1,100 sq. ft.

Owner Okaloosa County Owner's interest _____

Address BCC Okaloosa County 302 N. Wilson Street, Suite 203, Crestview, FL, 32536

Fee simple Title Holder, if other than owner _____

Address _____

GENERAL CONTRACTOR

Name Decks N Such Marine, Inc. Phone # 850.314.0444

Address P.O. Box 327, Ft. Walton Beach, FL 32549

Surety Bond Name United Casualty and Surety Insurance Company Phone # 617.471.1112

Address 292 Newbury St. #105, Boston, MA 02115-2801 Amount of Bond \$ 112,993.02

Name and Address of Financial Institution making a loan for the construction of the above improvements.
Name _____ Phone # _____

Address _____

Persons within the State of Florida designated by owner upon whom notices or other documents may be served as provided by Section 713.13 (1) (a) 7, Florida Statutes:

Name _____ Phone # _____

Address _____

In addition to himself, owner designates the following person to receive a copy of the lienor's notice as provided in Section 713.13 (1) (b), Florida Statutes. (Fill in at Owner's option)

Name _____ Phone # _____

Address _____

Expiration date of notice of commencement (the expiration date is one year from the date of recording unless a different date is specified)

WARNING TO OWNER: ANY PAYMENTS MADE BY THE OWNER AFTER THE EXPIRATION OF THE NOTICE OF COMMENCEMENT ARE CONSIDERED IMPROPER PAYMENTS UNDER CHAPTER 713, PART 1, SECTION 713.13, FLORIDA STATUTES, AND CAN RESULT IN YOUR PAYING TWICE FOR IMPROVEMENTS TO YOUR PROPERTY. A NOTICE OF COMMENCEMENT MUST BE RECORDED AND POSTED ON THE JOB SITE BEFORE THE FIRST INSPECTION. IF YOU INTEND TO OBTAIN FINANCING, CONSULT WITH YOUR LENDER OR AN ATTORNEY BEFORE COMMENCING WORK OR RECORDING YOUR NOTICE OF COMMENCEMENT.

I attest to the correctness of the information above.

Allen L. Lassiter
Owner Signature

Allen L. Lassiter
Print Name

STATE OF Florida
COUNTY OF Walton

Sworn to, Subscribed and Acknowledged before me by means of () physical presence or () online notarization, on this 20 day of May, 2021 by Allen Lassiter, who () is personally known to me or () produced identification

(notary stamp)



ANGELAM OVERLY
Commission # GG 254981
Expires September 3, 2022
Bonded Thru Budget Notary Services

Angelam Overly
No

CONTRACT#: C21-3015-FM
DECKS N SUCH MARINE, INC.
LONGWOOD/POQUITO BAYOU PARK EXTENSION
EXPIRES: 180 DAYS FROM NTP

CONTRACT#: C21-3015-FM
 DECKS N SUCH MARINE, INC.
 LONGWOOK/POQUITO BAYOU
 PARK EXTENSION

10 11

CERTIFICATE

This certificate is issued for informational purposes only. It does not grant any rights to any party nor can it be used, in any way, to modify coverage provided by such policies. Alteration of this certificate does not change the terms, exclusions or conditions of such policies. Coverage is subject to the provisions of the policies, including any exclusions or conditions, regardless of the provisions of any other contract, such as between the certificate holder and the Named Insured. The limits shown below are the limits provided at the policy inception. Subsequent paid claims may reduce these limits.

EXPIRES: 180 DAYS FROM NTP

issued

Certificate Holder: OKALOOSA COUNTY BOARD OF COUNTY COMMISSIONERS 1250 N EGLIN PKWY STE 100 SHALIMAR, FL USA 325791296	Named Insured: DECKS N SUCH MARINE, INC. PO BOX 327 FORT WALTON BEACH FL 32549-0327
--	---

Automobile Liability			
Insurer Name: Allstate Insurance Company			
Policy Number: 648145943			
<input type="checkbox"/> 1 -- Any Auto	<input type="checkbox"/> 2 -- Owned Autos Only	<input type="checkbox"/> 3 -- Owned Priv. Pass. Autos Only	
<input type="checkbox"/> 4 -- Owned Autos Other Than Priv. Pass. Autos Only	<input checked="" type="checkbox"/> 5 -- Owned Autos Subject to No Fault	<input type="checkbox"/> 6 -- Owned Autos Subject to a Compulsory UM Law	
<input checked="" type="checkbox"/> 7 -- Specifically Described Autos	<input type="checkbox"/> 8 -- Hired Autos Only	<input type="checkbox"/> 9 -- Nonowned Autos Only	
Policy Effective Date : 02-26-2020		Policy Expiration Date: 02-26-2021	
Limits of Insurance:	\$1,000,000 BI Per Person	Combined Single Limit (each accident) BI Per Accident PD Per Accident	
Description of Operations/Locations/Vehicles/Endorsements/Special Provisions			
Interested Party Type: Additional Insured - Municipality			
THIS CERTIFICATE DOES NOT GRANT ANY COVERAGE OR RIGHTS TO THE CERTIFICATE HOLDER. IF THIS CERTIFICATE INDICATES THAT THE CERTIFICATE HOLDER IS AN ADDITIONAL INSURED, THE POLICY(IES) MUST EITHER BE ENDORSED OR CONTAIN SPECIFIC LANGUAGE PROVIDING THE CERTIFICATE HOLDER WITH ADDITIONAL INSURED STATUS. THE CERTIFICATE HOLDER IS AN ADDITIONAL INSURED ONLY TO THE EXTENT INDICATED IN SUCH POLICY LANGUAGE OR ENDORSEMENT.			

Producer: STEPHEN MC MULLEN	C21-3015-FM Date: 01-05-21
Authorized Representative:	



Includes copyrighted material of Insurance Services Office, Inc., with its permission



POLICY NUMBER: 648145943

COMMERCIAL AUTO
CA 20 48 10 13

THIS ENDORSEMENT CHANGES THE POLICY. PLEASE READ IT CAREFULLY.

DESIGNATED INSURED FOR COVERED AUTOS LIABILITY COVERAGE

This endorsement modifies insurance provided under the following:

AUTO DEALERS COVERAGE FORM
BUSINESS AUTO COVERAGE FORM
MOTOR CARRIER COVERAGE FORM

With respect to coverage provided by this endorsement, the provisions of the Coverage Form apply unless modified by this endorsement.

This endorsement identifies person(s) or organization(s) who are "insureds" for Covered Autos Liability Coverage under the Who Is An Insured provision of the Coverage Form. This endorsement does not alter coverage provided in the Coverage Form.

This endorsement changes the policy effective on the inception date of the policy unless another date is indicated below.

Named Insured: DECKS N SUCH MARINE, INC.

Endorsement Effective Date: 01-05-2021

SCHEDULE

Name Of Person(s) Or Organization(s):

OKALOOSA COUNTY BOARD OF COUNTY COMMISSIONERS
1250 N EGLIN PKWY STE 100
SHALIMAR, FL USA 325791296

Information required to complete this Schedule, if not shown above, will be shown in the Declarations.

Each person or organization shown in the Schedule is an "insured" for Covered Autos Liability Coverage, but only to the extent that person or organization qualifies as an "insured" under the Who Is An Insured provision contained in Paragraph **A.1.** of Section **II** – Covered Autos Liability Coverage in the Business Auto and Motor Carrier Coverage Forms and Paragraph **D.2.** of Section **I** – Covered Autos Coverages of the Auto Dealers Coverage Form.



NOTICE TO PROCEED

**TO: Decks N Such Marine, Inc.
P.O. Box 327
Fort Walton Beach, FL 32549**

CONTRACT#: C21-3015-FM
DECKS N SUCH MARINE, INC.
LONGWOOD/POQUITO BAYOU PARK
EXTENSION
EXPIRES: 180 DAYS FROM NTP

PROJECT: Longwood/Poquito Bayou Park Dock Extension

DESCRIPTION: ITB PW 49-20 Contract C21-3015-PW

You are hereby notified you are able to commence WORK in accordance with the Agreement dated November 17, 2020. The work shall be substantially complete within 120 days from the date of this Notice to Proceed and shall be fully completed within 180 days of the date of this Notice to Proceed.

You are required to return an acknowledged copy of this **NOTICE TO PROCEED** to the **OWNER**: Okaloosa County Purchasing, Attention: DeRita Mason, 5479A Old Bethel Road, Crestview, FL 32536, within 15 days from the date this **NOTICE TO PROCEED** is fully executed.

Dated this 26th day of January, 2021

OKALOOSA COUNTY BOARD OF COUNTY COMMISSIONERS

OWNER

BY:

Jeff Hyde, Purchasing Manager

ACCEPTANCE OF NOTICE

Receipt of the above NOTICE TO PROCEED is hereby acknowledged.

Date of Commencement of Work: 02-01-2021

Decks N Such Marine, Inc.
Company Name

This the 26th day of January, 2021

Signature

By: Kirk Francis Project Manager
Type or Print Name/Title



CERTIFICATE OF LIABILITY INSURANCE

DATE (MM/DD/YYYY)

01/04/2021

THIS CERTIFICATE IS ISSUED AS A MATTER OF INFORMATION ONLY AND CONFERS NO RIGHTS UPON THE CERTIFICATE HOLDER. THIS CERTIFICATE DOES NOT AFFIRMATIVELY OR NEGATIVELY AMEND, EXTEND OR ALTER THE COVERAGE AFFORDED BY THE POLICIES BELOW. THIS CERTIFICATE OF INSURANCE DOES NOT CONSTITUTE A CONTRACT BETWEEN THE ISSUING INSURER(S), AUTHORIZED REPRESENTATIVE OR PRODUCER, AND THE CERTIFICATE HOLDER.

IMPORTANT: If the certificate holder is an ADDITIONAL INSURED, the policy(ies) must have ADDITIONAL INSURED provisions or be endorsed. If SUBROGATION IS WAIVED, subject to the terms and conditions of the policy, certain policies may require an endorsement. A statement on this certificate does not confer rights to the certificate holder in lieu of such endorsement(s).

PRODUCER DAN MILLER AGENCY, LLC 485 Mary Esther Blvd PO Box 291 Mary Esther FL 32569	CONTACT NAME: Dan Miller PHONE (A/C, No, Ext): (850) 243-5095 FAX (A/C, No): (850) 244-6567 E-MAIL ADDRESS:																				
	<table border="1"> <thead> <tr> <th colspan="2">INSURER(S) AFFORDING COVERAGE</th> <th>NAIC #</th> </tr> </thead> <tbody> <tr> <td>INSURER A:</td> <td>Kinsale Insurance Company c/o SLB</td> <td></td> </tr> <tr> <td>INSURER B:</td> <td></td> <td></td> </tr> <tr> <td>INSURER C:</td> <td></td> <td></td> </tr> <tr> <td>INSURER D:</td> <td></td> <td></td> </tr> <tr> <td>INSURER E:</td> <td></td> <td></td> </tr> <tr> <td>INSURER F:</td> <td></td> <td></td> </tr> </tbody> </table>	INSURER(S) AFFORDING COVERAGE		NAIC #	INSURER A:	Kinsale Insurance Company c/o SLB		INSURER B:			INSURER C:			INSURER D:			INSURER E:			INSURER F:	
INSURER(S) AFFORDING COVERAGE		NAIC #																			
INSURER A:	Kinsale Insurance Company c/o SLB																				
INSURER B:																					
INSURER C:																					
INSURER D:																					
INSURER E:																					
INSURER F:																					
INSURED Decks N Such Marine Inc. PO BOX 327 Fort Walton Beach FL 32549																					

COVERAGES **CERTIFICATE NUMBER:** CL211400979 **REVISION NUMBER:**

THIS IS TO CERTIFY THAT THE POLICIES OF INSURANCE LISTED BELOW HAVE BEEN ISSUED TO THE INSURED NAMED ABOVE FOR THE POLICY PERIOD INDICATED. NOTWITHSTANDING ANY REQUIREMENT, TERM OR CONDITION OF ANY CONTRACT OR OTHER DOCUMENT WITH RESPECT TO WHICH THIS CERTIFICATE MAY BE ISSUED OR MAY PERTAIN, THE INSURANCE AFFORDED BY THE POLICIES DESCRIBED HEREIN IS SUBJECT TO ALL THE TERMS, EXCLUSIONS AND CONDITIONS OF SUCH POLICIES. LIMITS SHOWN MAY HAVE BEEN REDUCED BY PAID CLAIMS.

INSR LTR	TYPE OF INSURANCE	ADDL INSP	SUBR WVD	POLICY NUMBER	POLICY EFF (MM/DD/YYYY)	POLICY EXP (MM/DD/YYYY)	LIMITS	
A	<input checked="" type="checkbox"/> COMMERCIAL GENERAL LIABILITY <input type="checkbox"/> CLAIMS-MADE <input checked="" type="checkbox"/> OCCUR GEN'L AGGREGATE LIMIT APPLIES PER: <input type="checkbox"/> POLICY <input checked="" type="checkbox"/> PRO JECT <input type="checkbox"/> LOC OTHER:	Y		1522426	12/02/2020	12/02/2021	EACH OCCURRENCE	\$ 1,000,000
	DAMAGE TO RENTED PREMISES (Ea occurrence)						\$ 100,000	
							MED EXP (Any one person)	\$ 5,000
							PERSONAL & ADV INJURY	\$ 1,000,000
							GENERAL AGGREGATE	\$ 2,000,000
							PRODUCTS - COMP/OP AGG	\$ 1,000,000
								\$
	AUTOMOBILE LIABILITY <input type="checkbox"/> ANY AUTO <input type="checkbox"/> OWNED AUTOS ONLY <input type="checkbox"/> SCHEDULED AUTOS <input type="checkbox"/> HIRED AUTOS ONLY <input type="checkbox"/> NON-OWNED AUTOS ONLY						COMBINED SINGLE LIMIT (Ea accident)	\$
							BODILY INJURY (Per person)	\$
							BODILY INJURY (Per accident)	\$
							PROPERTY DAMAGE (Per accident)	\$
								\$
	UMBRELLA LIAB <input type="checkbox"/> OCCUR EXCESS LIAB <input type="checkbox"/> CLAIMS-MADE DED RETENTION \$						EACH OCCURRENCE	\$
							AGGREGATE	\$
								\$
	WORKERS COMPENSATION AND EMPLOYERS' LIABILITY ANY PROPRIETOR/PARTNER/EXECUTIVE OFFICER/MEMBER EXCLUDED? (Mandatory in NH) <input type="checkbox"/> Y/N N/A If yes, describe under DESCRIPTION OF OPERATIONS below						PER STATUTE	OTH-ER
							E.L. EACH ACCIDENT	\$
							E.L. DISEASE - EA EMPLOYEE	\$
							E.L. DISEASE - POLICY LIMIT	\$

DESCRIPTION OF OPERATIONS / LOCATIONS / VEHICLES (ACORD 101, Additional Remarks Schedule, may be attached if more space is required)

CONTRACT#: C21-3015-FM
 DECKS N SUCH MARINE, INC.
 LONGWOOD/POQUITO BAYOU PARK EXTENSION
 EXPIRES: 180 DAYS FROM NTP

CERTIFICATE HOLDER

Okaloosa County Board of County Commissioners.
 302 N Wilson Street, Suite 301

Crestview,

FL 32536

SHOULD ANY OF THE ABOVE DESCRIBED POLICIES BE CANCELLED BEFORE THE EXPIRATION DATE THEREOF, NOTICE WILL BE DELIVERED IN ACCORDANCE WITH THE POLICY PROVISIONS.

AUTHORIZED REPRESENTATIVE

© 1988-2015 ACORD CORPORATION. All rights reserved.

WAIVER OF OUR RIGHT TO RECOVER FROM OTHERS ENDORSEMENT

We have the right to recover our payments from anyone liable for an injury covered by this policy. We will not enforce our right against the person or organization named in the Schedule. (This agreement applies only to the extent that you perform work under a written contract that requires you to obtain this agreement from us.)

This agreement shall not operate directly or indirectly to benefit anyone not named in the Schedule.

Schedule

**OKALOOSA COUNTY BOARD OF
COUNTY COMMISSIONERS
5497A OLD BETHEL ROAD
CRESTVIEW, FL 32536**

This endorsement changes the policy to which it is attached and is effective on the date issued unless otherwise stated.

(The information below is required only when this endorsement is issued subsequent to preparation of the policy.)

Insured: South East Personnel Leasing, Inc.

Insurance Company: Lion Insurance Co.

Policy #: WC 71949

Effective: 01/01/2021- 01/01/2022

Client: Decks N Such Marine, Inc. dba Silver Sands Development

Countersigned by: _____

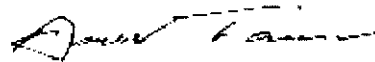

WC 00 03 13

(Ed. 4-84)

CERTIFICATE OF LIABILITY INSURANCE

Date
12/31/2020

Producer: Plymouth Insurance Agenc
2739 U.S. Highway 19 N.
Holiday, FL 34691
(727) 938-5562

This Certificate is issued as a matter of information only and confers no rights upon the Certificate Holder. This Certificate does not amend, extend or alter the coverage afforded by the policies below.

Insurers Affording Coverage

NAIC #

Insured: South East Personnel Leasing, Inc. & Subsidiaries
2739 U.S. Highway 19 N.
Holiday, FL 34691

Insurer A: Lion Insurance Company	11075
Insurer B:	
Insurer C:	
Insurer D:	
Insurer E:	

Coverages

The policies of insurance listed below have been issued to the insured named above for the policy period indicated. Notwithstanding any requirement, term or condition of any contract or other document with respect to which this certificate may be issued or may pertain, the insurance afforded by the policies described herein is subject to all the terms, exclusions, and conditions of such policies. Aggregate limits shown may have been reduced by paid claims.

INSR LTR	ADDL INSRD	Type of Insurance	Policy Number	Policy Effective Date (MM/DD/YY)	Policy Expiration Date (MM/DD/YY)	Limits	
		GENERAL LIABILITY <input type="checkbox"/> Commercial General Liability <input type="checkbox"/> Claims Made <input type="checkbox"/> Occur <hr/> General aggregate limit applies per: <input type="checkbox"/> Policy <input type="checkbox"/> Project <input type="checkbox"/> LOC				Each Occurrence	\$
						Damage to rented premises (EA occurrence)	\$
						Med Exp	\$
						Personal Adv Injury	\$
						General Aggregate	\$
						Products - Comp/Op Agg	\$
		AUTOMOBILE LIABILITY <input type="checkbox"/> Any Auto <input type="checkbox"/> All Owned Autos <input type="checkbox"/> Scheduled Autos <input type="checkbox"/> Hired Autos <input type="checkbox"/> Non-Owned Autos				Combined Single Limit (EA Accident)	\$
						Bodily Injury (Per Person)	\$
						Bodily Injury (Per Accident)	\$
						Property Damage (Per Accident)	\$
		EXCESS/UMBRELLA LIABILITY <input type="checkbox"/> Occur <input type="checkbox"/> Claims Made <input type="checkbox"/> Deductible				Each Occurrence	
						Aggregate	
A		Workers Compensation and Employers' Liability Any proprietor/partner/executive officer/member excluded? NO If Yes, describe under special provisions below.	WC 71949	01/01/2021	01/01/2022	<input checked="" type="checkbox"/> WC Statutory Limits <input type="checkbox"/> OTH-ER	
						E.L. Each Accident	\$1,000,000
						E.L. Disease - Ea Employee	\$1,000,000
						E.L. Disease - Policy Limits	\$1,000,000

Other

Lion Insurance Company is A.M. Best Company rated A (Excellent). AMB # 12616

Descriptions of Operations/Locations/Vehicles/Exclusions added by Endorsement/Special Provisions:

Client ID: 81-65-895

Coverage only applies to active employee(s) of South East Personnel Leasing, Inc. & Subsidiaries that are leased to the following "Client Company":

Decks N Such Marine, Inc. dba Silver Sands Development

Coverage only applies to injuries incurred by South East Personnel Leasing, Inc. & Subsidiaries active employee(s), while working in: FL

Coverage does not apply to statutory employee(s) or independent contractor(s) of the Client Company or any other entity.

A list of the active employee(s) leased to the Client Company can be obtained by faxing a request to (727) 937-2138 or email certificates@lioninsurancecompany.com

Project Name:

WAIVER OF SUBROGATION APPLIES IN FAVOR OF OKALOOSA COUNTY BOARD OF COUNTY COMMISSIONERS. ISSUE 12-31-20 (SS)

Begin Date: 2/2/2016

CERTIFICATE HOLDER

CANCELLATION

OKALOOSA COUNTY BOARD OF
COUNTY COMMISSIONERS
5497A OLD BETHEL ROAD
CRESTVIEW, FL 32536

Should any of the above described policies be cancelled before the expiration date thereof, the issuing insurer will endeavor to mail 30 days written notice to the certificate holder named to the left, but failure to do so shall impose no obligation or liability of any kind upon the insurer, its agents or representatives.

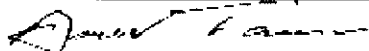

Longwood / Poquito Bayou Park Dock Extension

DEPUTY CLERK HOHARA
JD PEACOCK II CLERK OF COURTS,
OKALOOSA COUNTY, FLORIDA

DOCUMENT 00610 – PERFORMANCE BOND

CONTRACTOR (name and address):

Decks N Such Marine, Inc.
P.O. Box 327
Fort Walton Beach, FL 32549

SURETY (name and address of principal place of business):

United Casualty & Surety Insurance Company
292 Newbury St. #105
Boston, MA 02115-2801

OWNER (name and address): Okaloosa Board of County Commissioners
1250 N. Eglin Parkway
Shalimar, FL 32579

CONSTRUCTION CONTRACT

Effective Date of the Agreement: September 24, 2020
Amount: One Hundred Twelve Thousand, Nine Hundred Ninety-Three and 02/100 Dollars (\$112,993.02)
Description (name and location): Longwood / Poquito Bayou Park Dock Extension, Shalimar, Florida

BOND

Bond Number: UCSX372X3279
Date (not earlier than the Effective Date of the Agreement of the Construction Contract): October 23, 2020
Amount: One Hundred Twelve Thousand, Nine Hundred Ninety-Three and 02/100 Dollars (\$112,993.02)
Modifications to this Bond Form: None See Paragraph 16

Surety and Contractor, intending to be legally bound hereby, subject to the terms set forth below, do each cause this Performance Bond to be duly executed by an authorized officer, agent, or representative.

CONTRACTOR AS PRINCIPAL
Decks N Such Marine, Inc. (seal)
Contractor's Name and Corporate Seal

SURETY
United Casualty & Surety Insurance Company (seal)
Surety's Name and Corporate Seal

By: [Signature]
Signature

By: [Signature]
Signature (attach power of attorney)

Paul Kardos
Print Name

Kelly A. Specht
Print Name

President
Title

Attorney-in-Fact
Title

Attest: [Signature]
Signature

Attest: [Signature]
Signature

Project Manager
Title

Account Manager
Title



Notes: (1) Provide supplemental execution by any additional parties, such as joint venturers. (2) Any singular reference to Contractor, Surety, Owner, or other party shall be considered plural where applicable.

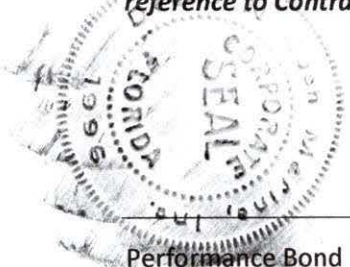

CONTRACT#: C21-3015-FM
DECKS N SUCH MARINE, INC.
LONGWOOD/POQUITO BAYOU PARK EXTENSION
EXPIRES: 180 DAYS FROM NTP

1. The Contractor and Surety, jointly and severally, bind themselves, their heirs, executors, administrators, successors, and assigns to the Owner for the performance of the Construction Contract, which is incorporated herein by reference.
2. If the Contractor performs the Construction Contract, the Surety and the Contractor shall have no obligation under this Bond, except when applicable to participate in a conference as provided in Paragraph 3.
3. If there is no Owner Default under the Construction Contract, the Surety's obligation under this Bond shall arise after:
 - 3.1 The Owner first provides notice to the Contractor and the Surety that the Owner is considering declaring a Contractor Default. Such notice shall indicate whether the Owner is requesting a conference among the Owner, Contractor, and Surety to discuss the Contractor's performance. If the Owner does not request a conference, the Surety may, within five (5) business days after receipt of the Owner's notice, request such a conference. If the Surety timely requests a conference, the Owner shall attend. Unless the Owner agrees otherwise, any conference requested under this Paragraph 3.1 shall be held within ten (10) business days of the Surety's receipt of the Owner's notice. If the Owner, the Contractor, and the Surety agree, the Contractor shall be allowed a reasonable time to perform the Construction Contract, but such an agreement shall not waive the Owner's right, if any, subsequently to declare a Contractor Default;
 - 3.2 The Owner declares a Contractor Default, terminates the Construction Contract and notifies the Surety; and
 - 3.3 The Owner has agreed to pay the Balance of the Contract Price in accordance with the terms of the Construction Contract to the Surety or to a contractor selected to perform the Construction Contract.
4. Failure on the part of the Owner to comply with the notice requirement in Paragraph 3.1 shall not constitute a failure to comply with a condition precedent to the Surety's obligations, or release the Surety from its obligations, except to the extent the Surety demonstrates actual prejudice.
5. When the Owner has satisfied the conditions of Paragraph 3, the Surety shall promptly and at the Surety's expense take one of the following actions:
 - 5.1 Arrange for the Contractor, with the consent of the Owner, to perform and complete the Construction Contract;
 - 5.2 Undertake to perform and complete the Construction Contract itself, through its agents or independent contractors;
 - 5.3 Obtain bids or negotiated proposals from qualified contractors acceptable to the Owner for a contract for performance and completion of the Construction Contract, arrange for a contract to be prepared for execution by the Owner and a contractor selected with the Owners concurrence, to be secured with performance and payment bonds executed by a qualified surety equivalent to the bonds issued on the Construction Contract, and pay to the Owner the amount of damages as described in Paragraph 7 in excess of the Balance of the Contract Price incurred by the Owner as a result of the Contractor Default; or
 - 5.4 Waive its right to perform and complete, arrange for completion, or obtain a new contractor, and with reasonable promptness under the circumstances:
 - 5.4.1 After investigation, determine the amount for which it may be liable to the Owner and, as soon as practicable after the amount is determined, make payment to the Owner; or
 - 5.4.2 Deny liability in whole or in part and notify the Owner, citing the reasons for denial.
6. If the Surety does not proceed as provided in Paragraph 5 with reasonable promptness, the Surety shall be deemed to be in default on this Bond seven days after receipt of an additional written notice from the Owner to the Surety demanding that the Surety perform its obligations under this Bond, and the Owner shall be entitled to enforce any remedy available to the Owner. If the Surety proceeds as provided in Paragraph 5.4, and the Owner refuses the payment or the Surety has denied liability, in whole or in part, without further notice the Owner shall be entitled to enforce any remedy available to the Owner.
7. If the Surety elects to act under Paragraph 5.1, 5.2, or 5.3, then the responsibilities of the Surety to the Owner shall not be greater than those of the Contractor under the Construction Contract, and the responsibilities of the Owner to the Surety shall not be greater than those of the Owner under the Construction Contract. Subject to the commitment by the Owner to pay the Balance of the Contract Price, the Surety is obligated, without duplication for:
 - 7.1 the responsibilities of the Contractor for correction of defective work and completion of the Construction Contract;
 - 7.2 additional legal, design professional, and delay costs resulting from the Contractor's Default, and resulting from the actions or failure to act of the Surety under Paragraph 5; and
 - 7.3 liquidated damages, or if no liquidated damages are specified in the Construction Contract, actual damages caused by delayed performance or non-performance of the Contractor.
8. If the Surety elects to act under Paragraph 5.1, 5.3, or 5.4, the Surety's liability is limited to the amount of this Bond.
9. The Surety shall not be liable to the Owner or others for obligations of the Contractor that are unrelated to the Construction Contract, and the Balance of the Contract Price shall not be reduced or set off on account of any such unrelated obligations. No right of action shall accrue on this Bond to any person or entity other than the Owner or its heirs, executors, administrators, successors, and assigns.
10. The Surety hereby waives notice of any change, including changes of time, to the Construction Contract or to related subcontracts, purchase orders, and other obligations.
11. Any proceeding, legal or equitable, under this Bond may be instituted in any court of competent jurisdiction in the location in which the work or part of the work is located and shall be instituted within two years after a declaration of Contractor Default or within two years after the Contractor ceased working or within two years after the Surety refuses or fails to perform its obligations under this Bond, whichever occurs first. If the provisions of this paragraph are void or prohibited by law, the minimum periods of limitations available to sureties as a defense in the jurisdiction of the suit shall be applicable.
12. Notice to the Surety, the Owner, or the Contractor shall be mailed or delivered to the address shown on the page on which their signature appears.
13. When this Bond has been furnished to comply with a statutory or other legal requirement in the location where the construction was to be performed, any provision in this Bond conflicting with said statutory or legal requirement shall be deemed deleted herefrom and provisions conforming to such statutory or other legal requirement shall be deemed incorporated herein. When so furnished, the intent is that this

Bond shall be construed as a statutory bond and not as a common law bond.

14. Definitions

14.1 Balance of the Contract Price: The total amount payable by the Owner to the Contractor under the Construction Contract after all proper adjustments have been made including allowance for the Contractor for any amounts received or to be received by the Owner in settlement of insurance or other claims for damages to which the Contractor is entitled, reduced by all valid and proper payments made to or on behalf of the Contractor under the Construction Contract.

14.2 Construction Contract: The agreement between the Owner and Contractor identified on the cover page, including all Contract Documents and changes made to the agreement and the Contract Documents.

14.3 Contractor Default: Failure of the Contractor, which has not been remedied or waived, to perform or otherwise to comply with a material term of the Construction Contract.

14.4 Owner Default: Failure of the Owner, which has not been remedied or waived, to pay the Contractor as required under the Construction Contract or to perform and complete or comply with the other material terms of the Construction Contract.

14.5 Contract Documents: All the documents that comprise the agreement between the Owner and Contractor.

15. If this Bond is issued for an agreement between a contractor and subcontractor, the term Contractor in this Bond shall be deemed to be Subcontractor and the term Owner shall be deemed to be Contractor.

16. Modifications to this Bond are as follows:

END OF DOCUMENT 00610 – PERFORMANCE BOND

California All-Purpose Certificate of Acknowledgment

A notary public or other officer completing this certificate verifies only the identity of the individual who signed the document to which this certificate is attached, and not the truthfulness, accuracy, or validity of that document.

State of California

County of Orange

} s.s.

On October 23, 2020 before me, Bethany Mercer, Notary Public

Name of Notary Public, Title

personally appeared Kelly A. Specht

Name of Signer (1)

Name of Signer (2)

who proved to me on the basis of satisfactory evidence to be the person(s) whose name(s) is/are subscribed to the within instrument and acknowledged to me that he/she/they executed the same in his/her/their authorized capacity(ies), and that by his/her/their signature(s) on the instrument the person(s), or the entity upon behalf of which the person(s) acted, executed the instrument.

I certify under PENALTY OF PERJURY under the laws of the State of California that the foregoing paragraph is true and correct.

WITNESS my hand and official seal.

Signature of Notary Public



Seal

OPTIONAL INFORMATION

Although the information in this section is not required by law, it could prevent fraudulent removal and reattachment of this acknowledgment to an unauthorized document and may prove useful to persons relying on the attached document.

Description of Attached Document

The preceding Certificate of Acknowledgment is attached to a document titled/for the purpose of Performance Bond#UCSX372X3279

containing 3 pages, and dated October 23, 2020

The signer(s) capacity or authority is/are as:

- Individual(s)
 Attorney-in-fact
 Corporate Officer(s) _____
Title(s)

- Guardian/Conservator
 Partner - Limited/General
 Trustee(s)
 Other: _____

representing: United Casualty and Surety Insurance Company
Name(s) of Person(s) Entity(ies) Signer is Representing

Additional Information

Method of Signer Identification

Proved to me on the basis of satisfactory evidence:
 form(s) of identification credible witness(es)

Notarial event is detailed in notary journal on:

Page # _____ Entry # _____

Notary contact: _____

Other

- Additional Signer Signer(s) Thumbprints(s)



UNITED CASUALTY AND SURETY INSURANCE COMPANY
 US Casualty and Surety Insurance Company
 United Surety Insurance Company

POWER OF ATTORNEY

Agency No. 171372

KNOW ALL MEN BY THESE PRESENTS: That United Casualty and Surety Insurance Company, a corporation of the State of Nebraska, and US Casualty and Surety Insurance Company and United Surety Insurance Company, assumed names of United Casualty and Surety Insurance Company (collectively, the Companies), do by these presents make, constitute and appoint:

Kelly A. Specht, Kandis Gregory, Richard P. Ford, Thomas C. Buckner, Michael Herranen, Bethany Mercer

its true and lawful Attorney(s)-in-Fact, each in their separate capacity if more than one is named above, with full power and authority hereby conferred in its name, place and stead, to execute, acknowledge and deliver any and all bonds, recognizances, undertakings or other instruments or contracts of suretyship to include riders, amendments, and consents of surety. This Power of Attorney shall expire without further action on December 31st, 2023.

This Power of Attorney is granted under and by authority of the following resolutions adopted by the Board of Directors of the Companies at a meeting duly called and held on the 1st day of July, 1993:

Resolved that the President, Treasurer, or Secretary be and they are hereby authorized and empowered to appoint Attorneys-in-Fact of the Company, in its name and as its acts to execute and acknowledge for and on its behalf as Surety any and all bonds, recognizances, contracts of indemnity, waivers of citation and all other writings obligatory in the nature thereof, with power to attach thereto the seal of the Company. Any such writings so executed by such Attorneys-in-Fact shall be binding upon the Company as if they had been duly executed and acknowledged by the regularly elected Officers of the Company in their own proper persons.

That the signature of any officer authorized by Resolutions of this Board and the Company seal may be affixed by facsimile to any power of attorney or special power of attorney or certification of either given for the execution of any bond, undertaking, recognizance or other written obligation in the nature thereof; such signature and seal, when so used being hereby adopted by the Company as the original signature of such officer and the original seal of the Company, to be valid and binding upon the Company with the same force and effect as though manually affixed.

IN WITNESS WHEREOF, the Companies have caused this instrument to be signed and their corporate seals to be hereunto affixed, this 1st day of August, 2019.

UNITED CASUALTY AND SURETY INSURANCE COMPANY
US Casualty and Surety Insurance Company
United Surety Insurance Company

 Joel R. Chachkes, Treasurer



Corporate Seals

Commonwealth of Massachusetts
 County of Suffolk ss:

On this 1st day of August, 2019, before me, Thomas P. Carrigan, Jr., a notary public, personally appeared Joel R. Chachkes, Treasurer of United Casualty and Surety Insurance Company, US Casualty and Surety Insurance Company and United Surety Insurance Company, who proved to me on the basis of satisfactory evidence to be the person whose name is subscribed to the within instrument and acknowledged to me that he executed the same in his authorized capacity, and that by his signature on the instrument the person(s), or the entity on behalf of which the person(s) acted, executed the instrument.

I certify under PENALTY OF PERJURY under the laws of the Commonwealth of Massachusetts that the foregoing paragraph is true and correct.
 WITNESS my hand and seal.

 _____ (Seal)
 Thomas P. Carrigan, Jr., Notary Public Commission Expires: 10/31/2025

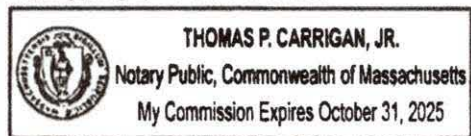

I, Robert F. Thomas, Chief Operating Officer of United Casualty and Surety Insurance Company, US Casualty and Surety Insurance Company and United Surety Insurance Company do hereby certify that the above and foregoing is a true and correct copy of a Power of Attorney, executed by said Companies, which is still in full force and effect; furthermore, the resolutions of the Board of Directors, set out in the Power of Attorney are in full force and effect.

In Witness Whereof, I have hereunto set my hand and affixed the seals of said Companies at Boston, Massachusetts this 23rd day of October, 2020.

Corporate Seals



 Robert F. Thomas, Chief Operating Officer

DOCUMENT 00620 – PAYMENT BOND

CONTRACTOR (name and address):

Decks N Such Marine, Inc.
P.O. Box 327
Fort Walton Beach, FL 32549

SURETY (name and address of principal place of business):

United Casualty & Surety Insurance Company
292 Newbury St. #105
Boston, MA 02115-2801

OWNER (name and address): Okaloosa Board of County Commissioners
1250 N. Eglin Parkway
Shalimar, FL 32579

CONSTRUCTION CONTRACT

Effective Date of the Agreement: September 24, 2020
Amount: One Hundred Twelve Thousand, Nine Hundred Ninety-Three and 02/100 Dollars (\$112,993.02)
Description (name and location): Longwood / Poquito Bayou Park Dock Extension, Shalimar, Florida

BOND

Bond Number: UCSX372X3279
Date (not earlier than the Effective Date of the Agreement of the Construction Contract): October 23, 2020
Amount: One Hundred Twelve Thousand, Nine Hundred Ninety-Three and 02/100 Dollars (\$112,993.02)
Modifications to this Bond Form: [X] None [] See Paragraph 18

Surety and Contractor, intending to be legally bound hereby, subject to the terms set forth below, do each cause this Payment Bond to be duly executed by an authorized officer, agent, or representative.

CONTRACTOR AS PRINCIPAL
Decks N Such Marine, Inc. (seal)
Contractor's Name and Corporate Seal

By: [Signature]
Signature

Print Name

Title

Attest: [Signature]
Signature

Title

SURETY
United Casualty & Surety Insurance Company (seal)
Surety's Name and Corporate Seal

By: [Signature]
Signature (attach power of attorney)

Kelly A. Specht
Print Name

Attorney-in-Fact
Title

Attest: [Signature]
Signature

Account Manager
Title



Notes: (1) Provide supplemental execution by any additional parties, such as joint venturers. (2) Any singular reference to Contractor, Surety, Owner, or other party shall be considered plural where applicable.



CONTRACT#: C21-3015-FM
DECKS N SUCH MARINE, INC.
LONGWOOD/POQUITO BAYOU PARK EXTENSION
EXPIRES: 180 DAYS FROM NTP

1. The Contractor and Surety, jointly and severally, bind themselves, their heirs, executors, administrators, successors, and assigns to the Owner to pay for labor, materials, and equipment furnished for use in the performance of the Construction Contract, which is incorporated herein by reference, subject to the following terms.

2. If the Contractor promptly makes payment of all sums due to Claimants, and defends, indemnifies, and holds harmless the Owner from claims, demands, liens, or suits by any person or entity seeking payment for labor, materials, or equipment furnished for use in the performance of the Construction Contract, then the Surety and the Contractor shall have no obligation under this Bond.

3. If there is no Owner Default under the Construction Contract, the Surety's obligation to the Owner under this Bond shall arise after the Owner has promptly notified the Contractor and the Surety (at the address described in Paragraph 13) of claims, demands, liens, or suits against the Owner or the Owner's property by any person or entity seeking payment for labor, materials, or equipment furnished for use in the performance of the Construction Contract, and tendered defense of such claims, demands, liens, or suits to the Contractor and the Surety.

4. When the Owner has satisfied the conditions in Paragraph 3, the Surety shall promptly and at the Surety's expense defend, indemnify, and hold harmless the Owner against a duly tendered claim, demand, lien, or suit.

5. The Surety's obligations to a Claimant under this Bond shall arise after the following:

5.1 Claimants who do not have a direct contract with the Contractor,

5.1.1 have furnished a written notice of non-payment to the Contractor, stating with substantial accuracy the amount claimed and the name of the party to whom the materials were, or equipment was, furnished or supplied or for whom the labor was done or performed, within ninety (90) days after having last performed labor or last furnished materials or equipment included in the Claim; and

5.1.2 have sent a Claim to the Surety (at the address described in Paragraph 13).

5.2 Claimants who are employed by or have a direct contract with the Contractor have sent a Claim to the Surety (at the address described in Paragraph 13).

6. If a notice of non-payment required by Paragraph 5.1.1 is given by the Owner to the Contractor, that is sufficient to satisfy a Claimant's obligation to furnish a written notice of non-payment under Paragraph 5.1.1.

7. When a Claimant has satisfied the conditions of Paragraph 5.1 or 5.2, whichever is applicable, the Surety shall promptly and at the Surety's expense take the following actions:

7.1 Send an answer to the Claimant, with a copy to the Owner, within sixty (60) days after receipt of the Claim, stating the amounts that are undisputed and the basis for challenging any amounts that are disputed; and

7.2 Pay or arrange for payment of any undisputed amounts.

7.3 The Surety's failure to discharge its obligations under Paragraph 7.1 or 7.2 shall not be deemed to constitute a waiver

of defenses the Surety or Contractor may have or acquire as to a Claim, except as to undisputed amounts for which the Surety and Claimant have reached agreement. If, however, the Surety fails to discharge its obligations under Paragraph 7.1 or 7.2, the Surety shall indemnify the Claimant for the reasonable attorney's fees the Claimant incurs thereafter to recover any sums found to be due and owing to the Claimant.

8. The Surety's total obligation shall not exceed the amount of this Bond, plus the amount of reasonable attorney's fees provided under Paragraph 7.3, and the amount of this Bond shall be credited for any payments made in good faith by the Surety.

9. Amounts owed by the Owner to the Contractor under the Construction Contract shall be used for the performance of the Construction Contract and to satisfy claims, if any, under any construction performance bond. By the Contractor furnishing and the Owner accepting this Bond, they agree that all funds earned by the Contractor in the performance of the Construction Contract are dedicated to satisfy obligations of the Contractor and Surety under this Bond, subject to the Owner's priority to use the funds for the completion of the work.

10. The Surety shall not be liable to the Owner, Claimants, or others for obligations of the Contractor that are unrelated to the Construction Contract. The Owner shall not be liable for the payment of any costs or expenses of any Claimant under this Bond, and shall have under this Bond no obligation to make payments to or give notice on behalf of Claimants, or otherwise have any obligations to Claimants under this Bond.

11. The Surety hereby waives notice of any change, including changes of time, to the Construction Contract or to related subcontracts, purchase orders, and other obligations.

12. No suit or action shall be commenced by a Claimant under this Bond other than in a court of competent jurisdiction in the state in which the project that is the subject of the Construction Contract is located or after the expiration of one year from the date (1) on which the Claimant sent a Claim to the Surety pursuant to Paragraph 5.1.2 or 5.2, or (2) on which the last labor or service was performed by anyone or the last materials or equipment were furnished by anyone under the Construction Contract, whichever of (1) or (2) first occurs. If the provisions of this paragraph are void or prohibited by law, the minimum period of limitation available to sureties as a defense in the jurisdiction of the suit shall be applicable.

13. Notice and Claims to the Surety, the Owner, or the Contractor shall be mailed or delivered to the address shown on the page on which their signature appears. Actual receipt of notice or Claims, however accomplished, shall be sufficient compliance as of the date received.

14. When this Bond has been furnished to comply with a statutory or other legal requirement in the location where the construction was to be performed, any provision in this Bond conflicting with said statutory or legal requirement shall be deemed deleted herefrom and provisions conforming to such statutory or other legal requirement shall be deemed incorporated herein. When so furnished, the intent is that this Bond shall be construed as a statutory bond and not as a common law bond.

15. Upon requests by any person or entity appearing to be a potential beneficiary of this Bond, the Contractor and Owner shall promptly furnish a copy of this Bond or shall permit a copy to be made.

16. Definitions

16.1 Claim: A written statement by the Claimant including at a minimum:

1. The name of the Claimant;
2. The name of the person for whom the labor was done, or materials or equipment furnished;
3. A copy of the agreement or purchase order pursuant to which labor, materials, or equipment was furnished for use in the performance of the Construction Contract;
4. A brief description of the labor, materials, or equipment furnished;
5. The date on which the Claimant last performed labor or last furnished materials or equipment for use in the performance of the Construction Contract;
6. The total amount earned by the Claimant for labor, materials, or equipment furnished as of the date of the Claim;
7. The total amount of previous payments received by the Claimant; and
8. The total amount due and unpaid to the Claimant for labor, materials, or equipment furnished as of the date of the Claim.

16.2 Claimant: An individual or entity having a direct contract with the Contractor or with a subcontractor of the Contractor to furnish labor, materials, or equipment for use in the performance of the Construction Contract. The term Claimant also includes any individual or entity that has rightfully asserted a claim under an applicable mechanic's lien or similar

statute against the real property upon which the Project is located. The intent of this Bond shall be to include without limitation in the terms of "labor, materials, or equipment" that part of the water, gas, power, light, heat, oil, gasoline, telephone service, or rental equipment used in the Construction Contract, architectural and engineering services required for performance of the work of the Contractor and the Contractor's subcontractors, and all other items for which a mechanic's lien may be asserted in the jurisdiction where the labor, materials, or equipment were furnished.

16.3 Construction Contract: The agreement between the Owner and Contractor identified on the cover page, including all Contract Documents and all changes made to the agreement and the Contract Documents.

16.4 Owner Default: Failure of the Owner, which has not been remedied or waived, to pay the Contractor as required under the Construction Contract or to perform and complete or comply with the other material terms of the Construction Contract.

16.5 Contract Documents: All the documents that comprise the agreement between the Owner and Contractor.

17. If this Bond is issued for an agreement between a contractor and subcontractor, the term Contractor in this Bond shall be deemed to be Subcontractor and the term Owner shall be deemed to be Contractor.

18. Modifications to this Bond are as follows:

END OF DOCUMENT 00620 – PAYMENT BOND

California All-Purpose Certificate of Acknowledgment

A notary public or other officer completing this certificate verifies only the identity of the individual who signed the document to which this certificate is attached, and not the truthfulness, accuracy, or validity of that document.

State of California

County of Orange

} S.S.

On October 23, 2020 before me, Bethany Mercer, Notary Public
Name of Notary Public, Title

personally appeared Kelly A. Specht
Name of Signer (1)

Name of Signer (2)

who proved to me on the basis of satisfactory evidence to be the person(s) whose name(s) is/are subscribed to the within instrument and acknowledged to me that he/she/they executed the same in his/her/their authorized capacity(ies), and that by his/her/their signature(s) on the instrument the person(s), or the entity upon behalf of which the person(s) acted, executed the instrument.

I certify under PENALTY OF PERJURY under the laws of the State of California that the foregoing paragraph is true and correct.

WITNESS my hand and official seal.

Signature of Notary Public



Seal

OPTIONAL INFORMATION

Although the information in this section is not required by law, it could prevent fraudulent removal and reattachment of this acknowledgment to an unauthorized document and may prove useful to persons relying on the attached document.

Description of Attached Document

The preceding Certificate of Acknowledgment is attached to a document titled/for the purpose of _____
Payment Bond#UCSX372X3279

containing 3 pages, and dated October 23, 2020

The signer(s) capacity or authority is/are as:

- Individual(s)
 Attorney-in-fact
 Corporate Officer(s) _____
Titles

- Guardian/Conservator
 Partner - Limited/General
 Trustee(s)
 Other: _____

representing: United Casualty and Surety Insurance Company
Names of Person(s) Entity(ies) Signer is Representing

Additional Information

Method of Signer Identification

Proved to me on the basis of satisfactory evidence:

- form(s) of identification credible witness(es)

Notarial event is detailed in notary journal on:

Page # _____ Entry # _____

Notary contact: _____

Other

- Additional Signer Signer(s) Thumbprints(s)



UNITED CASUALTY AND SURETY INSURANCE COMPANY
 US Casualty and Surety Insurance Company
 United Surety Insurance Company

POWER OF ATTORNEY

Agency No. 171372

KNOW ALL MEN BY THESE PRESENTS: That United Casualty and Surety Insurance Company, a corporation of the State of Nebraska, and US Casualty and Surety Insurance Company and United Surety Insurance Company, assumed names of United Casualty and Surety Insurance Company (collectively, the Companies), do by these presents make, constitute and appoint:

Kelly A. Specht, Kandis Gregory, Richard P. Ford, Thomas C. Buckner, Michael Herranen, Bethany Mercer

its true and lawful Attorney(s)-in-Fact, each in their separate capacity if more than one is named above, with full power and authority hereby conferred in its name, place and stead, to execute, acknowledge and deliver any and all bonds, recognizances, undertakings or other instruments or contracts of suretyship to include riders, amendments, and consents of surety. This Power of Attorney shall expire without further action on December 31st, 2023.

This Power of Attorney is granted under and by authority of the following resolutions adopted by the Board of Directors of the Companies at a meeting duly called and held on the 1st day of July, 1993:

Resolved that the President, Treasurer, or Secretary be and they are hereby authorized and empowered to appoint Attorneys-in-Fact of the Company, in its name and as its acts to execute and acknowledge for and on its behalf as Surety any and all bonds, recognizances, contracts of indemnity, waivers of citation and all other writings obligatory in the nature thereof, with power to attach thereto the seal of the Company. Any such writings so executed by such Attorneys-in-Fact shall be binding upon the Company as if they had been duly executed and acknowledged by the regularly elected Officers of the Company in their own proper persons.

That the signature of any officer authorized by Resolutions of this Board and the Company seal may be affixed by facsimile to any power of attorney or special power of attorney or certification of either given for the execution of any bond, undertaking, recognizance or other written obligation in the nature thereof; such signature and seal, when so used being hereby adopted by the Company as the original signature of such officer and the original seal of the Company, to be valid and binding upon the Company with the same force and effect as though manually affixed.

IN WITNESS WHEREOF, the Companies have caused this instrument to be signed and their corporate seals to be hereunto affixed, this 1st day of August, 2019.



UNITED CASUALTY AND SURETY INSURANCE COMPANY
US Casualty and Surety Insurance Company
United Surety Insurance Company

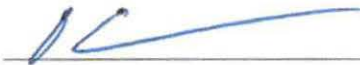

 Joel R. Chachkes, Treasurer

Corporate Seals

Commonwealth of Massachusetts
 County of Suffolk ss:

On this 1st day of August, 2019, before me, Thomas P. Carrigan, Jr., a notary public, personally appeared Joel R. Chachkes, Treasurer of United Casualty and Surety Insurance Company, US Casualty and Surety Insurance Company and United Surety Insurance Company, who proved to me on the basis of satisfactory evidence to be the person whose name is subscribed to the within instrument and acknowledged to me that he executed the same in his authorized capacity, and that by his signature on the instrument the person(s), or the entity on behalf of which the person(s) acted, executed the instrument.

I certify under PENALTY OF PERJURY under the laws of the Commonwealth of Massachusetts that the foregoing paragraph is true and correct.
 WITNESS my hand and seal.

 _____ (Seal)
 Thomas P. Carrigan, Jr., Notary Public Commission Expires: 10/31/2025

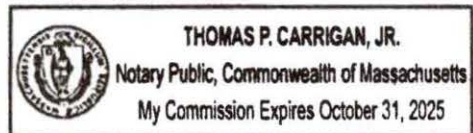

I, Robert F. Thomas, Chief Operating Officer of United Casualty and Surety Insurance Company, US Casualty and Surety Insurance Company and United Surety Insurance Company do hereby certify that the above and foregoing is a true and correct copy of a Power of Attorney, executed by said Companies, which is still in full force and effect; furthermore, the resolutions of the Board of Directors, set out in the Power of Attorney are in full force and effect.

In Witness Whereof, I have hereunto set my hand and affixed the seals of said Companies at Boston, Massachusetts this 23rd day of October, 2020.

Corporate Seals





 Robert F. Thomas, Chief Operating Officer

**PROCUREMENT/CONTRACT/LEASE
INTERNAL COORDINATION SHEET**

Procurement/Contract/Lease Number: TBD 49-20 Tracking Number: 4104-20
Procurement/Contractor/Lessee Name: Decks N Sudo Grant Funded: YES ___ NO X
Purpose: Longwood/Poquinta Bayou Dock Extension
Date/Term: 180 calendar days 1. GREATER THAN \$100,000
Department #: 3179 2. GREATER THAN \$50,000
Account #: 563790 3. \$50,000 OR LESS
Amount: \$112,993.02
Department: PW Dept. Monitor Name: Andy

Purchasing Review

Procurement or Contract/Lease requirements are met:
DeRita Mason Date: 8-19-2020
Purchasing Manager or designee Jeff Hyde, DeRita Mason, Jessica Darr, Angela Etheridge

2CFR Compliance Review (if required)

Approved as written: NO Federal funds Grant Name: _____

Date: _____
Grants Coordinator Danielle Garcia

Risk Management Review

Approved as written: see email attached Date: 8-19-2020

Risk Manager or designee Edith Gibson or Karen Donaldson

County Attorney Review

Approved as written: see email attached Date: 9-8-2020

County Attorney Lynn Hoshihara, Kerry Parsons or Designee

IT Review (if applicable)

Approved as written: _____ Date: _____

DeRita Mason

From: Parsons, Kerry <KParsons@ngn-tally.com>
Sent: Tuesday, September 8, 2020 8:55 AM
To: DeRita Mason
Cc: Roy Petrey; Lynn Hoshihara NGN-Tally
Subject: RE: ITB PW 49-20 Longwood/Poquito Bayou Park Dock Extension

This is approved for legal purposes.

Kerry A. Parsons, Esq.



1500 Mahan Dr. Ste. 200
Tallahassee, FL 32308
T. (850) 224-4070
kparsons@ngn-tally.com

The information contained in this e-mail message is intended for the personal and confidential use of the recipient(s) named above. This message and its attachments may be an attorney-client communication and, as such, is privileged and confidential. If the reader of this message is not the intended recipient or an agent responsible for delivering it to the intended recipient, you are hereby notified that you have received this document in error and that any review, dissemination, distribution, or copying of this message is strictly prohibited. If you have received this communication in error, please notify us immediately by telephone or e-mail and delete the original message. Thank you!

From: Roy Petrey <rpetry@myokaloosa.com>
Sent: Monday, August 31, 2020 2:23 PM
To: Parsons, Kerry <KParsons@ngn-tally.com>
Subject: RE: ITB PW 49-20 Longwood/Poquito Bayou Park Dock Extension

Kerry,

There is no arbitration clause in 7.10.C. Might you have meant 7.7.C on the same page and contains arbitration as a form of resolution? If so, that has been revised to delete arbitration.
Article 7.10.B does have an arbitration clause but it is removed in the Supplementary Conditions, page 00800-5.
Call if we need to discuss.

Thanks,
Roy

Please note: Due to Florida's very broad public records laws, most written communications to or from County employees regarding County business are public records, available to the public and media upon request. Therefore, this written e-mail communication, including your e-mail address, may be subject to public disclosure.

From: Parsons, Kerry <KParsons@ngn-tally.com>
Sent: Saturday, August 29, 2020 3:00 PM
To: DeRita Mason <dmason@myokaloosa.com>
Cc: Lynn Hoshihara <lhoshihara@myokaloosa.com>; Lisa Price <lprice@myokaloosa.com>; Roy Petrey <rpetry@myokaloosa.com>
Subject: RE: ITB PW 49-20 Longwood/Poquito Bayou Park Dock Extension

The following sections need supplemental conditions that delete out the arbitration clause: 7.10(c) and 7.10(B).



Board of County Commissioners Purchasing Department

State of Florida

Date: August 14, 2020

OKALOOSA COUNTY PURCHASING DEPARTMENT
NOTICE OF AWARD
ITB PW 49-20

Longwood/Poquito Bayou Park Dock Extension

Okaloosa County would like to thank all businesses which submitted responses to Longwood/Poquito Bayou Park Dock Extension. (ITB PW 49-20)

After in-depth examination of all responses in accordance with the County's Purchasing Manual, the County announces its intent to award the contract/purchase order to the following:

Decks N Such Marine, Inc.
P.O. Box 327
Fort Walton Beach, FL 32549

Any person/entity desiring to file a procurement protest must meet all the standards and criteria in accordance with Section 31 of the Okaloosa County Purchasing Manual. Failure to file a protest within the time prescribed in Section 31.02 of the Okaloosa County Purchasing Manual, shall constitute a waiver of protest proceedings.

Respectfully,

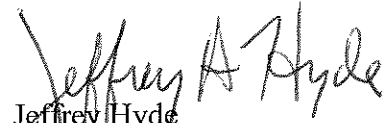
Jeffrey Hyde
Purchasing Manager

ALERT: SAM.gov will be down for scheduled maintenance Saturday, 08/15/2020 from 8:00 AM to 10:00 PM

<h3>Entity Dashboard</h3> <ul style="list-style-type: none"> ▶ Entity Overview ▶ Entity Registration <ul style="list-style-type: none"> ▶ Core Data ▶ Assertions ▶ Reps & Certs ▶ POCs ▶ Exclusions <ul style="list-style-type: none"> ▶ Active Exclusions ▶ Inactive Exclusions ▶ Excluded Family Members <div style="border: 1px solid black; padding: 5px; text-align: center; margin-top: 10px;"> RETURN TO SEARCH </div>	<p>DECKS N SUCH MARINE, INC DUNS: 945169233 CAGE Code: 079E6 Status: Expired Expiration Date: 01/11/2017 Purpose of Registration: All Awards</p> <hr/> <p>2 MAPLES ST NW FORT WALTON BEACH, FL, 32548, UNITED STATES</p>
	<h4>Entity Overview</h4> <div style="border: 1px solid black; padding: 5px; margin-bottom: 10px;"> <h5>Entity Registration Summary</h5> <p>Name: DECKS N SUCH MARINE, INC Doing Business As: SILVER SANDS DEVELOP Business Type: Business or Organization Last Updated By: Kirk Franco Registration Status: Expired Activation Date: 01/12/2016 Expired On: 01/11/2017</p> </div> <div style="border: 1px solid black; padding: 5px;"> <h5>Exclusion Summary</h5> <p>Active Exclusion Records? No</p> </div>



IBM-P-20200717-1140
WWW8

Search Records	Disclaimers	FAPIS.gov
Data Access	Accessibility	GSA.gov/LAE
Check Status	Privacy Policy	GSA.gov
About		USA.gov
Help		



[Department of State](#) / [Division of Corporations](#) / [Search Records](#) / [Search by FEI/EIN Number](#) /

Detail by FEI/EIN Number

Florida Profit Corporation
DECKS N SUCH MARINE, INC.

Filing Information

Document Number P96000007198
FEI/EIN Number 59-3421521
Date Filed 01/18/1996
State FL
Status ACTIVE
Last Event REINSTATEMENT
Event Date Filed 10/19/2004

Principal Address

P.O. Box 327
FORT WALTON BEACH, FL 32549

Changed: 03/20/2015

Mailing Address

P.O. BOX 327
FT. WALTON BEACH, FL 32549

Changed: 01/06/2009

Registered Agent Name & Address

HARTZOG, PAUL E
787 BOULEVARD OF THE CHAMPIONS
SHALIMAR, FL 32579

Name Changed: 01/06/2009

Address Changed: 01/20/2020

Officer/Director Detail

Name & Address

Title DPVT

HARTZOG, PAUL E
P.O. BOX 327
FORT WALTON BEACH, FL 32549

Annual Reports

Report Year	Filed Date
2018	01/09/2018
2019	02/12/2019
2020	01/20/2020

Document Images

01/20/2020 -- ANNUAL REPORT	View image in PDF format
02/12/2019 -- ANNUAL REPORT	View image in PDF format
01/09/2018 -- ANNUAL REPORT	View image in PDF format
02/14/2017 -- ANNUAL REPORT	View image in PDF format
04/14/2016 -- ANNUAL REPORT	View image in PDF format
03/20/2015 -- ANNUAL REPORT	View image in PDF format
04/21/2014 -- ANNUAL REPORT	View image in PDF format
04/25/2013 -- ANNUAL REPORT	View image in PDF format
01/06/2012 -- ANNUAL REPORT	View image in PDF format
02/10/2011 -- ANNUAL REPORT	View image in PDF format
01/25/2010 -- ANNUAL REPORT	View image in PDF format
01/06/2009 -- ANNUAL REPORT	View image in PDF format
07/14/2008 -- ANNUAL REPORT	View image in PDF format
02/23/2007 -- ANNUAL REPORT	View image in PDF format
05/04/2006 -- ANNUAL REPORT	View image in PDF format
04/07/2005 -- ANNUAL REPORT	View image in PDF format
10/19/2004 -- REINSTATEMENT	View image in PDF format
03/17/2003 -- ANNUAL REPORT	View image in PDF format
10/01/2002 -- Merger	View image in PDF format
04/09/2002 -- ANNUAL REPORT	View image in PDF format
08/03/2001 -- ANNUAL REPORT	View image in PDF format
11/13/2000 -- REINSTATEMENT	View image in PDF format
10/25/1999 -- REINSTATEMENT	View image in PDF format
03/13/1998 -- ANNUAL REPORT	View image in PDF format
03/20/1997 -- ANNUAL REPORT	View image in PDF format
01/18/1996 -- DOCUMENTS PRIOR TO 1997	View image in PDF format

Contract Documents - Specifications – Drawings

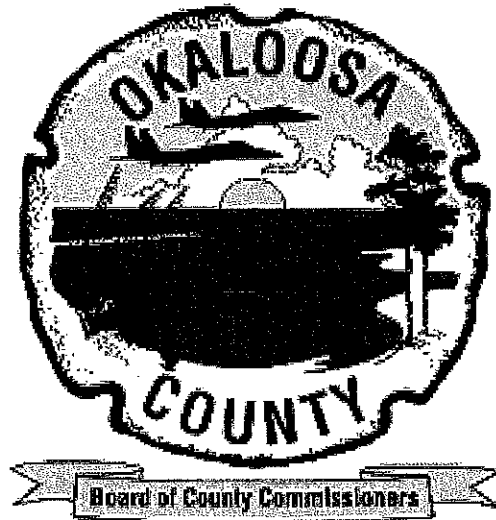

ITB PW 49-20

**Longwood / Poquito Bayou Park
Dock Extension**

Shalimar, Florida

OKALOOSA COUNTY COMMISSIONERS

Trey Goodwin, Chair, District 4
Carolyn Ketchel, Vice Chair, District 2
Graham W. Fountain, District 1
Charles K. Windes, Jr., District 5
Nathan Boyles, District 3

COUNTY ADMINISTRATOR

John Hofstad

PUBLIC WORKS DIRECTOR

Jason Autrey, P.E.

COUNTY ENGINEER

Scott Bitterman, P.E.

ENGINEER OF RECORD

Duncan Greer, P.E.

CONTRACT#: C21-3015-FM
DECKS N SUCH MARINE, INC.
LONGWOOD/POQUITO BAYOU PARK EXTENSION
EXPIRES: 180 DAYS FROM NTP

DOCUMENT 00520 – AGREEMENT BETWEEN OWNER AND CONTRACTOR FOR CONSTRUCTION CONTRACT –

THIS AGREEMENT is by and between Okaloosa County, a political subdivision of the State of Florida, by and through its Board of County Commissioners, situated at 1250 N. Eglin Parkway, Shalimar, Florida (“OWNER”) and Decks N Such Marine, Inc. of 787 Boulevard of the Champions, Shalimar, Florida 32579, certified to do business in the state of Florida (“CONTRACTOR”).

OWNER and CONTRACTOR hereby agree as follows:

ARTICLE 1 – WORK

- 1.01 CONTRACTOR shall complete all WORK as specified or indicated in the Contract Documents. The WORK is generally described as follows: Longwood / Poquito Bayou Park Dock Extension

ARTICLE 2 – THE PROJECT

- 2.01 The Project, of which the Work under the Contract Documents is a part, is generally described as follows: Construct Longwood / Poquito Bayou Park Dock Extension.

ARTICLE 3 – ENGINEER

- 3.01 The part of the Project that pertains to the WORK has been designed by Taylor Engineering Inc.
3.02 The OWNER has retained the County Engineer (“ENGINEER”) to act as OWNER’s representative, assume all duties and responsibilities, and have the rights and authority assigned to ENGINEER in the Contract Documents in connection with the completion of the Work in accordance with the Contract Documents.

ARTICLE 4 – CONTRACT TIMES

- 4.01 Time of the Essence
A. All time limits for Milestones, if any, Substantial Completion, and completion and readiness for final payment as stated in the Contract Documents are of the essence of the Contract.
- 4.02 Contract Times: Days
A. The Work will be substantially completed within 120 calendar days after the date when the Contract Times commence to run as provided in Paragraph 4.01 of the General Conditions, and completed and ready for final payment in accordance with Paragraph 15.06 of the General Conditions within 180 calendar days after the date when the Contract Times commence to run.
- 4.03 Liquidated Damages
A. Section 337.18(2) of the Florida Statutes, requires the OWNER adopt regulations for the determination of default and provisions that the Contractor pay liquidated damages (daily charge per calendar day) for any failure of the Contractor to complete the Contract work within the Contract Time.
B. CONTRACTOR and OWNER recognize that time is of the essence as stated in Paragraph 4.01 above and that OWNER will suffer financial and other losses if the Work is not completed and Milestones not achieved within the times specified in Paragraph 4.02 above, plus any extensions thereof allowed in accordance with the Contract. The parties also recognize the delays, expense, and difficulties involved in proving in a legal proceeding the actual loss suffered by OWNER if the Work is not completed on time. Accordingly, instead of requiring any such proof, OWNER and CONTRACTOR agree that as liquidated damages for delay. Contractor specifically acknowledges that the liquidated damages is not a penalty and waives any right to argue such at a later time.

1. Substantial Completion: CONTRACTOR shall pay OWNER \$500.00 for each day that expires after the time (as duly adjusted pursuant to the Contract) specified in Paragraph 4.02.A above for Substantial Completion until the Work is substantially complete.
2. Completion of Remaining Work: After Substantial Completion, if CONTRACTOR shall neglect, refuse, or fail to complete the remaining Work within the Contract Times (as duly adjusted pursuant to the Contract) for completion and readiness for final payment, CONTRACTOR shall pay OWNER \$500.00 for each day that expires after such time until the Work is completed and ready for final payment.
3. Liquidated damages for failing to timely attain Substantial Completion and final completion are not additive and will not be imposed concurrently.

ARTICLE 5 – CONTRACT PRICE

- 5.01 OWNER shall pay CONTRACTOR for completion of the Work in accordance with the Contract Documents the amounts equal to the sum of the amounts determined pursuant to Paragraph 5.01.A below:
- A. For all Work, at the prices stated in CONTRACTOR's Bid, attached hereto as an exhibit.

As provided in Paragraph 13.03 of the General Conditions, estimated quantities are not guaranteed, and determinations of actual quantities and classifications are to be made by ENGINEER as provided in Paragraph 10.06 of the General Conditions. Unit prices have been computed as proved in Paragraph 13.03 of the General Conditions.

Contract Amount of \$112,993.02 (one hundred twelve thousand nine hundred ninety-three dollars and two cents).

ARTICLE 6 – PAYMENT PROCEDURES

- 6.01 Submittal and Processing of Payments
- A. CONTRACTOR shall submit Applications for Payment in accordance with Article 15 of the General Conditions. Applications for Payment will be processed by ENGINEER as provided in the General Conditions.
- 6.02 Progress Payments; Retainage
- A. OWNER shall make progress payments on account of the Contract Price on the basis of CONTRACTOR's Applications for Payment in accordance with § 218.70-218.79 F.S. (Local Government Prompt Payment Act) during performance of the Work as provided in Paragraph 6.02.A.1 below, provided that such Applications for Payment have been submitted in a timely manner and otherwise meet the requirements of the Contract. All such payments will be measured by the Schedule of Values established in Paragraph 2.03 of the General Conditions (and in the case of Unit Price Work based on the number of units completed) or, in the event there is no Schedule of Values, as provided elsewhere in the Contract.
 1. Progress payments will be made in an amount equal to the percentage indicated below but, in each case, less the aggregate of payments previously made and less such amounts as OWNER may withhold, including but not limited to liquidated damages, in accordance with the Contract:
 - a. 95 percent of Work completed (with the balance being retainage)
 - b. 95 percent of cost of materials and equipment not incorporated in the Work (with the balance being retainage).
- 6.03 Final Payment
- A. Upon final completion and acceptance of the Work in accordance with Paragraph 15.06 of the General Conditions, OWNER shall pay the remainder of the Contract Price as recommended by ENGINEER as provided in said Paragraph 15.06.

ARTICLE 7 – INTEREST

- 7.01 All amounts not paid when due shall bear interest at the rate of 1% percent per month in accordance with § 218.735 F.S. (Local Government Prompt Payment Act).

ARTICLE 8 – CONTRACTOR’S REPRESENTATIONS

- 8.01 In order to induce OWNER to enter into this Contract, CONTRACTOR makes the following representations:
- A. CONTRACTOR has examined and carefully studied the Contract Documents, and any data and reference items identified in the Contract Documents.
 - B. CONTRACTOR has visited the Site, conducted a thorough, alert visual examination of the Site and adjacent areas, and become familiar with and is satisfied as to the general, local, and Site conditions that may affect cost, progress, and performance of the Work.
 - C. CONTRACTOR is familiar with and is satisfied as to all Federal, State and Local Laws and Regulations that may affect cost, progress, and performance of the Work.
 - D. CONTRACTOR has carefully studied all, if any: (1) reports of explorations and tests of subsurface conditions at or adjacent to the Site and all drawings of physical conditions relating to existing surface or subsurface structures at the Site that have been identified in the Supplementary Conditions, especially with respect to Technical Data in such reports and drawings, and (2) reports and drawings relating to Hazardous Environmental Conditions, if any, at or adjacent to the Site that have been identified in the Supplementary Conditions, especially with respect to Technical Data in such reports and drawings.
 - E. CONTRACTOR has considered the information known to CONTRACTOR itself; information commonly known to CONTRACTORS doing business in the locality of the Site; information and observations obtained from visits to the Site; the Contract Documents; and the Site-related reports, if any, and drawings identified in the Contract Documents, with respect to the effect of such information, observations, and documents on (1) the cost, progress, and performance of the Work; (2) the means, methods, techniques, sequences, and procedures of construction to be employed by CONTRACTOR; and (3) CONTRACTOR’s safety precautions and programs.
 - F. Based on the information and observations referred to in the preceding paragraph, CONTRACTOR agrees that no further examinations, investigations, explorations, tests, studies, or data are necessary for the performance of the Work at the Contract Price, within the Contract Times, and in accordance with the other terms and conditions of the Contract.
 - G. CONTRACTOR is aware of the general nature of work to be performed by OWNER and others at the Site that relates to the Work as indicated in the Contract Documents.
 - H. CONTRACTOR has given ENGINEER written notice of all conflicts, errors, ambiguities, or discrepancies that CONTRACTOR has discovered in the Contract Documents, and the written resolution thereof by ENGINEER is acceptable to CONTRACTOR.
 - I. The Contract Documents are generally sufficient to indicate and convey understanding of all terms and conditions for performance and furnishing of the Work.
 - J. CONTRACTOR’s entry into this Contract constitutes an incontrovertible representation by CONTRACTOR that without exception all prices in the Agreement are premised upon performing and furnishing the Work required by the Contract Documents.

ARTICLE 9 – CONTRACT DOCUMENTS

9.01 Contents

- A. The Contract Documents consist of the following:
 - 1. Bid Form with Attachments (pages 00410-1 to 00410-22, inclusive).
 - 2. This Agreement (pages 00520-1 to 00520-10, inclusive).

3. Performance bond (pages 00610-1 to 00610-3, inclusive).
4. Payment bond (pages 00620-1 to 00620-3, inclusive).
5. EJCDC General Conditions (pages 00700-1 to 00700-62, inclusive).
6. Supplementary Conditions (pages 00800-1 to 00800-10, inclusive).
7. Summary of Work (page 01010-1, inclusive).
8. Project Coordination (pages 01040-1 to 01040-3, inclusive).
9. Warranties and Manuals (page 01350-1, inclusive).
10. Temporary Facilities (pages 01500-1 to 01500-3, inclusive).
11. Project Closeout (pages 01700-1 to 01700-3, inclusive).
12. Record Documents (pages 01750-1 to 01750-3, inclusive).
13. Drawings consisting of 7 sheets with each sheet bearing the following general title: LONGWOOD / POQUITO BAYOU PARK DOCK EXTENSION, (incorporated by reference).
14. Appendix A – FDEP Permit (pages 1-25, inclusive).
15. Addenda (numbers 1 to 2, inclusive).
16. The following which may be delivered or issued on or after the Effective Date of the Contract and are not attached hereto:
 - a. Notice to Proceed.
 - b. Work Change Directives.
 - c. Contractor's Application for Payment
 - d. Change Orders.
 - e. Field Orders.
- B. The documents listed in Paragraph 9.01.A are attached to this Agreement (except as expressly noted otherwise above).
- C. There are no Contract Documents other than those listed above in this Article 9.
- D. The Contract Documents may only be amended, modified, or supplemented as provided in the General Conditions.

ARTICLE 10 – MISCELLANEOUS

10.01 Terms

- A. Terms used in this Agreement will have the meanings stated in the General Conditions and the Supplementary Conditions.

10.02 Assignment of Contract

- A. Unless expressly agreed to elsewhere in the Contract, no assignment by a party hereto of any rights under or interests in the Contract will be binding on another party hereto without the written consent of the party sought to be bound; and, specifically but without limitation, money that may become due and money that is due may not be assigned without such consent (except to the extent that the effect of this restriction may be limited by law), and unless specifically stated to the contrary in any written consent to an assignment, no assignment will release or discharge the assignor from any duty or responsibility under the Contract Documents.

10.03 Successors and Assigns

- A. OWNER and CONTRACTOR each binds itself, its successors, assigns, and legal representatives to the other party hereto, its successors, assigns, and legal representatives in respect to all covenants, agreements, and obligations contained in the Contract Documents.

10.04 Severability

- A. Any provision or part of the Contract Documents held to be void or unenforceable under any Law or Regulation shall be deemed stricken, and all remaining provisions shall continue to be valid and binding upon OWNER and CONTRACTOR, who agree that the Contract Documents shall be reformed to replace such stricken provision or part thereof with a valid and enforceable provision that comes as close as possible to expressing the intention of the stricken provision.

10.05 CONTRACTOR's Certifications

- A. CONTRACTOR certifies that it has not engaged in corrupt, fraudulent, collusive, or coercive practices in competing for or in executing the Contract. For the purposes of this Paragraph 10.05:
1. "corrupt practice" means the offering, giving, receiving, or soliciting of any thing of value likely to influence the action of a public official in the bidding process or in the Contract execution;
 2. "fraudulent practice" means an intentional misrepresentation of facts made (a) to influence the bidding process or the execution of the Contract to the detriment of OWNER, (b) to establish Bid or Contract prices at artificial non-competitive levels, or (c) to deprive OWNER of the benefits of free and open competition;
 3. "collusive practice" means a scheme or arrangement between two or more Bidders, with or without the knowledge of OWNER, a purpose of which is to establish Bid prices at artificial, non-competitive levels; and
 4. "coercive practice" means harming or threatening to harm, directly or indirectly, persons or their property to influence their participation in the bidding process or affect the execution of the Contract.

10.06 Independent CONTRACTORS

- A. CONTRACTOR enters into the Contract as, and shall continue to be, an independent CONTRACTOR. All services shall be performed only by CONTRACTOR and CONTRACTOR's employees. Under no circumstances shall CONTRACTOR or any of CONTRACTOR's employees look to the OWNER as his/her employer, or as partner, agent or principal. Neither CONTRACTOR, nor any of CONTRACTOR's employees, shall be entitled to any benefits accorded to the OWNER's employees, including without limitation worker's compensation, disability insurance, vacation or sick pay. CONTRACTOR shall be responsible for providing, at CONTRACTOR's expense, and in CONTRACTOR's name, unemployment, disability, worker's compensation and other insurance as well as licenses and permits usual and necessary for conducting the services to be provided under this Contract.

10.07 Audit Provision

- A. The OWNER and/or its designee shall have the right from time to time at its sole expense to audit the compliance by the CONTRACTOR with the terms, conditions, obligations, limitations, restrictions and requirements of this Agreement and such right shall extend for a period of three (3) years after termination of this Agreement.

10.08 Public Records

- A. CONTRACTOR shall adhere to the Public Records law of Florida.
- B. Specifically, CONTRACTOR must:
1. Keep and maintain public records require by the OWNER to perform the service.
 2. Upon request from the OWNER's custodian of public records, provide the OWNER with a copy of the requested records or allow the records to be inspected or copied within a reasonable time at a cost that does not exceed the cost provided in chapter 119 Florida Statutes or as otherwise provided by law.
 3. Ensure that public records that are exempt or confidential and exempt from public records disclosure requirements are not disclosed except as authorized by law for the duration of the Agreement term and following completion of the Agreement if the CONTRACTOR does not transfer the records to the OWNER.
 4. Upon completion of the Agreement, transfer, at no cost, to the OWNER all public records in possession of the CONTRACTOR or keep and maintain public records required by the OWNER to perform the service. If the CONTRACTOR transfers all public records to the OWNER upon completion of the Contract, the CONTRACTOR shall destroy any duplicate public records that are exempt or confidential and exempt from public records disclosure requirements. If the CONTRACTOR keeps and maintains public records upon completion of the Contract, the CONTRACTOR shall meet all applicable requirements for retaining the public records. All records stored electronically must be provided to the OWNER, upon the request from the

OWNER's custodian of public records, in a format that is compatible with the information technology system of the OWNER.

- C. **IF THE CONTRACTOR HAS QUESTIONS REGARDING THE APPLICATION OF CHAPTER 119, FLORIDA STATUTES, TO THE CONTRACTOR'S DUTY TO PROVIDE PUBLIC RECORDS RELATING TO THIS CONTRACT, CONTACT THE CUSTODIAN OF PUBLIC RECORDS AT OKALOOSA COUNTY RISK MANAGEMENT DEPARTMENT 5479 OLD BETHEL ROAD CRESTVIEW, FL 32536 PHONE (850) 689-5977 riskinfo@co.okaloosa.fl.us.**

10.09 Third Party Beneficiaries

- A. It is specifically agreed between the parties executing this Agreement that it is not intended by any of the provisions of any part of the Agreement to create in the public or any member thereof, a third party beneficiary under this Agreement, or to authorize anyone not a part to this Agreement to maintain a suit for personal injuries or property damage pursuant to the terms or provision of this Agreement.

10.10 Other Provisions

- A. OWNER stipulates that if the General Conditions that are made a part of this Contract are based on EJCDC® C-700, Standard General Conditions for the Construction Contract, published by the ENGINEERS Joint Contract Documents Committee®, and if OWNER is the party that has furnished said General Conditions, then OWNER has plainly shown all modifications to the standard wording of such published document to the CONTRACTOR, through a process such as highlighting or "track changes" (redline/strikeout), or in the Supplementary Conditions.
- B. The individual signing this Agreement on behalf of CONTRACTOR represents and warrants that he or she is duly authorized and has legal capacity to execute and deliver this Agreement. The CONTRACTOR represent and warrants to the OWNER that the execution and delivery of the Agreement and the performance of CONTRACTOR's obligations hereunder have been duly authorized and that the Agreement is a valid and legal agreement binding on the CONTRACTOR and enforceable in accordance with its terms.
- C. The waiver by a party of any breach or default in performance shall not be deemed to constitute a waiver of any other or succeeding breach or default. The failure of the OWNER to enforce any of the provisions hereof shall not be construed to be a waiver of the right of the OWNER thereafter to enforce such provisions.
- D. All notices required by this Agreement shall be in writing to the representatives listed below:

AUTHORIZED REPRESENTATIVES:

OWNER:

Chairman -- Board of County Commissioners

Address

1250 N. Eglin Parkway

Shalimar, FL 32579

Phone

850-651-7105

CONTRACTOR:

Decks N Such Marine, Inc.

Address

787 Boulevard of the Champions

Shalimar, Florida 32579

Phone

850-314-0444

10.11 Equal Opportunity Employment

- A. During the performance of this CONTRACT, the contractor agrees as follows:
 1. The contractor will not discriminate against any employee or applicant for employment because of race, color, religion, sex, or national origin. The contractor will take affirmative

action to ensure that applicants are employed, and that employees are treated during employment without regard to their race, color, religion, sex, or national origin. Such action shall include, but not be limited to the following: employment, upgrading, demotion, or transfer; recruitment or recruitment advertising; layoff or termination; rates of pay or other forms of compensation; and selection for training, including apprenticeship. The contractor agrees to post in conspicuous places, available to employees and applicants for employment, notices to be provided setting forth the provisions of this nondiscrimination clause.

2. The contractor will, in all solicitations or advertisements for employees placed by or on behalf of the contractor, state that all qualified applicants will receive considerations for employment without regard to race, color, religion, sex, or national origin.
3. The contractor will send to each labor union or representative of workers with which he has a collective bargaining agreement or other contract or understanding, a notice to be provided advising the said labor union or workers' representatives of the contractor's commitments under this section, and shall post copies of the notice in conspicuous places available to employees and applicants for employment.
4. The contractor will comply with all provisions of Executive Order 11246 of September 24, 1965, and of the rules, regulations, and relevant orders of the Secretary of Labor.
5. The contractor will furnish all information and reports required by Executive Order 11246 of September 24, 1965, and by rules, regulations, and orders of the Secretary of Labor, or pursuant thereto, and will permit access to his books, records, and accounts by the administering agency and the Secretary of Labor for purposes of investigation to ascertain compliance with such rules, regulations, and orders
6. In the event of the contractor's noncompliance with the nondiscrimination clauses of this contract or with any of the said rules, regulations, or orders, this contract may be canceled, terminated, or suspended in whole or in part and the contractor may be declared ineligible for further Government contracts or federally assisted construction contracts in accordance with procedures authorized in Executive Order 11246 of September 24, 1965, and such other sanctions may be imposed and remedies invoked as provided in Executive Order 11246 of September 24, 1965, or by rule, regulation, or order of the Secretary of Labor, or as otherwise provided by law.
7. The contractor will include the portion of the sentence immediately preceding paragraph (1) and the provisions of paragraphs (1) through (7) in every subcontract or purchase order unless exempted by rules, regulations, or orders of the Secretary of Labor issued pursuant to section 204 of Executive Order 11246 of September 24, 1965, so that such provisions will be binding upon each subcontractor or vendor. The contractor will take such action with respect to any subcontract or purchase order as the administering agency may direct as a means of enforcing such provisions, including sanctions for noncompliance: provided, however, that in the event a contractor becomes involved in, or is threatened with, litigation with a subcontractor or vendor as a result of such direction by the administering agency the contractor may request the United States to enter into such litigation to protect the interests of the United States.

10.12 Federal Fair Labor Standards Act (Federal Minimum Wage)

- A. All contracts and subcontracts that result from this solicitation incorporate by reference the provisions of 29 CFR part 201, the Federal Fair Labor Standards Act (FLSA), with the same force and effect as if given in full text. The FLSA sets minimum wage, overtime pay, recordkeeping, and child labor standards for full and part time workers.
- B. The CONTRACTOR has full responsibility to monitor compliance to the referenced statute or regulation. The CONTRACTOR must address any claims or disputes that arise from this requirement directly with the U.S. Department of Labor – Wage and Hour Division.

10.13 Occupational Safety and Health Act of 1970

- A. All contracts and subcontracts that result from this solicitation incorporate by reference the requirements of 29 CFR Part 1910 with the same force and effect as if given in full text. CONTRACTOR must provide a work environment that is free from recognized hazards that may cause death or serious physical harm to the employee. The CONTRACTOR retains full responsibility to monitor its compliance and their subcontractor's compliance with the applicable requirements of the Occupational Safety and Health Act of 1970 (20 CFR Part 1910). CONTRACTOR must address any claims or disputes that pertain to a referenced requirement directly with the U.S. Department of Labor – Occupational Safety and Health Administration.

10.14 E-Verify

- A. Enrollment and verification requirements.
1. If the CONTRACTOR is not enrolled as a Federal Contractor in E-Verify at time of contract award, the CONTRACTOR shall-
 - a. Enroll. Enroll as a Federal Contractor in the E-Verify Program within thirty (30) calendar days of Contract award;
 - b. Verify all new employees. Within ninety (90) calendar days of enrollment in the E-Verify program, begin to use E-Verify to initiate verification of employment eligibility of all new hires of the CONTRACTOR, who are working in the United States, whether or not assigned to the Contract, within three (3) business days after the date of hire (but see paragraph (3.) of this section); and,
 - c. Verify employees assigned to the Contract. For each employee assigned to the Contract, initiate verification within ninety (90) calendar days after date of enrollment or within thirty (30) calendar days of the employee's assignment to the Contract, whichever date is later (but see paragraph (4.) of this section.)
 2. If the CONTRACTOR is enrolled as a Federal Contractor in E-Verify at time of Contract award, the CONTRACTOR shall use E-Verify to initiate verification of employment eligibility of
 - a. All new employees.
 - 1) Enrolled ninety (90) calendar days or more. The CONTRACTOR shall initiate verification of all new hires of the CONTRACTOR, who are working in the United States, whether or not assigned to the Contract, within three (3) business days after the date of hire (but see paragraph (3.) of this section); or
 - b. Enrolled less than ninety (90) calendar days. Within ninety (90) calendar days after enrollment as a Federal Contractor in E-Verify, the CONTRACTOR shall initiate verification of all new hires of the CONTRACTOR, who are working in the United States, whether or not assigned to the contract, within three (3) business days after the date of hire (but see paragraph (3.) of this section; or
 - 1) Employees assigned to the Contract. For each employee assigned to the Contract, the CONTRACTOR shall initiate verification within ninety (90) calendar days after date of Contract award or within thirty (30) days after assignment to the Contract, whichever date is later (but see paragraph (4.) of this section.)
 3. If the CONTRACTOR is an institution of higher education (as defined at 20 U.S.C. 1001(a)); a State of local government or the government of a Federally recognized Indian tribe, or a surety performing under a takeover agreement entered into with a Federal agency pursuant to a performance bond, the CONTRACTOR may choose to verify only employees assigned to the Contract, whether existing employees or new hires. The CONTRACTOR shall follow the applicable verification requirements of (1.) or (2.), respectively, except that any requirement for verification of new employees applies only to new employees assigned to the Contract.
 4. Option to verify employment eligibility of all employees. The CONTRACTOR may elect to verify all existing employees hired after November 6, 1986 (after November 27, 2009, in the Commonwealth of the Northern Mariana Islands), rather than just those employees assigned to the Contract. The CONTRACTOR shall initiate verification for each existing employee

- working in the United States who was hired after November 6, 1986 (after November 27, 2009, in the Commonwealth of the Northern Mariana Islands), within one hundred eighty (180) calendar days of-
- a. Enrollment in the E-Verify program; or
 - b. Notification to E-Verify Operations of the CONTRACTOR's decision to exercise this option, using the Contract information provided in the E-Verify program Memorandum of Understanding (MOU)
5. The CONTRACTOR shall comply, for the period of performance of this Contract, with the requirements of the E-Verify program MOU.
- a. The Department of Homeland Security (DHS) or the Social Security Administration (SSA) may terminate the CONTRACTOR's MOU and deny access to the E-Verify system in accordance with the terms of the MOU. In such case, the CONTRACTOR, will be referred to a suspension or debarment official.
 - b. During the period between termination of the MOU and a decision by the suspension or debarment official whether to suspend or debar, the CONTRACTOR is excused from its obligations under paragraph (b) of this clause. If the suspension or debarment official determines not to suspend or debar the CONTRACTOR, then the CONTRACTOR must reenroll in E-Verify.
 - c. Web site. Information on registration for and use of the E-Verify program can be obtained via the Internet at the Department of Homeland Security Web site: <http://www.dhs.gov/E-Verify>.
 - d. Individuals previously verified. The CONTRACTOR is not required by this clause to perform additional employment verification using E-Verify for any employee-
 - 1) Whose employment eligibility was previously verified by the CONTRACTOR through the E-Verify program;
 - 2) Who has been granted and holds an active U.S. Government security clearance for access to confidential, secret, or top secret information in accordance with the National Industrial Security Program Operating Manual; or
 - 3) Who has undergone a completed background investigation and been issued credentials pursuant to Homeland Security Presidential Directive (HSPD)-12. Policy for a Common Identification Standard for Federal Employees and Contractors.
6. Subcontracts. The CONTRACTOR shall include the requirements of this clause, including this paragraph € (appropriately modified for identification of the parties in each subcontract that -
- a. Is for
 - 1) Commercial and noncommercial services (except for commercial services that are part of the purchase of a COTS item (or an item that would be a COTS item, but for minor modifications), performed by the COTS provider, and are normally provided for that COTS item); or
 - 2) Construction;
 - b. Has a value of more than \$3,500; and
 - c. Includes work performed in the United States.

IN WITNESS WHEREOF, OWNER and CONTRACTOR have signed this Agreement.

11/17/2020 ML Carson, BCC Records

This Agreement will be effective on 7/24/2020 (which is the Effective Date of the Contract).

OWNER:

BOARD OF COUNTY COMMISSIONERS
OKALOOSA COUNTY, FLORIDA



Robert A. "Trey" Goodwin, III, Chairman

CONTRACTOR:

Decks N Such Marine, Inc.

By:

Title:

President

(If CONTRACTOR is a corporation, a partnership, or a joint venture, attach evidence of authority to sign.)

Attest:

Title:

Attest:

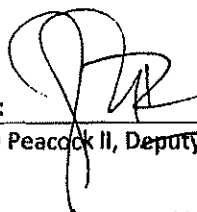
JD Peacock II, Deputy Clerk of Courts

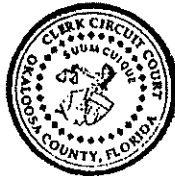

Address for giving notices:

1250 N. Eglin Parkway

Shallmar, FL 32579

Address for giving notices:

787 Boulevard of the Champions

Shallmar, Florida 32579

License No.: CGC1516044

END OF DOCUMENT 00520 – AGREEMENT BETWEEN OWNER & CONTRACTOR
FOR CONSTRUCTION CONTRACT

DOCUMENT 00410 – BID FORM WITH ATTACHMENTS
--

ARTICLE 1 – BID RECIPIENT

- 1.01 This Bid is submitted to: Okaloosa County, a political subdivision of the State of Florida.
- 1.02 The undersigned BIDDER proposes and agrees, if this Bid is accepted, to enter into an Agreement with OWNER in the form included in the Bidding Documents to perform all Work as specified or indicated in the Bidding Documents for the prices and within the times indicated in this Bid and in accordance with the other terms and conditions of the Bidding Documents.

ARTICLE 2 – BIDDER'S ACKNOWLEDGEMENTS

- 2.01 BIDDER accepts all of the terms and conditions of the Instructions to BIDDERS, including without limitation those dealing with the disposition of Bid security. This Bid will remain subject to acceptance for 60 days after the Bid opening, or for such longer period of time that BIDDER may agree to in writing upon request of OWNER.

ARTICLE 3 – BIDDER'S REPRESENTATIONS

- 3.01 In submitting this Bid, BIDDER represents that:
 - A. BIDDER has examined and carefully studied the Bidding Documents, and any data and reference items identified in the Bidding Documents, and hereby acknowledges receipt of the Addenda as defined in Attachment "A".
 - B. BIDDER has visited the Site, conducted a thorough, alert visual examination of the Site and adjacent areas, and become familiar with and satisfied itself as to the general, local, and Site conditions that may affect cost, progress, and performance of the Work.
 - C. BIDDER is familiar with and has satisfied itself as to all Laws and Regulations that may affect cost, progress, and performance of the Work.
 - D. BIDDER has carefully studied all: (1) reports, if any, of explorations and tests of subsurface conditions at or adjacent to the Site and all drawings of physical conditions relating to existing surface or subsurface structures at the Site that have been identified in the Supplementary Conditions, especially with respect to Technical Data in such reports and drawings, and (2) reports and drawings relating to Hazardous Environmental Conditions, if any, at or adjacent to the Site that have been identified in the Supplementary Conditions, especially with respect to Technical Data in such reports and drawings.
 - E. BIDDER has considered the information known to BIDDER itself; information commonly known to contractors doing business in the locality of the Site; information and observations obtained from visits to the Site; the Bidding Documents; and any Site-related reports and drawings identified in the Bidding Documents, with respect to the effect of such information, observations, and documents on (1) the cost, progress, and performance of the Work; (2) the means, methods, techniques, sequences, and procedures of construction to be employed by BIDDER; and (3) BIDDER's safety precautions and programs.
 - F. BIDDER agrees, based on the information and observations referred to in the preceding paragraph, that no further examinations, investigations, explorations, tests, studies, or data are necessary for the determination of this Bid for performance of the Work at the price bid and within the times required, and in accordance with the other terms and conditions of the Bidding Documents.
 - G. BIDDER is aware of the general nature of work to be performed by OWNER and others at the Site that relates to the Work as indicated in the Bidding Documents.

- H. BIDDER has given Engineer written notice of all conflicts, errors, ambiguities, or discrepancies that BIDDER has discovered in the Bidding Documents, and confirms that the written resolution thereof by Engineer is acceptable to BIDDER.
- I. The Bidding Documents are generally sufficient to indicate and convey understanding of all terms and conditions for the performance and furnishing of the Work.
- J. The submission of this Bid constitutes an incontrovertible representation by BIDDER that BIDDER has complied with every requirement of this Article, and that without exception the Bid and all prices in the Bid are premised upon performing and furnishing the Work required by the Bidding Documents.

ARTICLE 4 – BIDDER’S CERTIFICATION

4.01 BIDDER certifies that:

- A. This Bid is genuine and not made in the interest of or on behalf of any undisclosed individual or entity and is not submitted in conformity with any collusive agreement or rules of any group, association, organization, or corporation;
- B. BIDDER has not directly or indirectly induced or solicited any other BIDDER to submit a false or sham Bid;
- C. BIDDER has not solicited or induced any individual or entity to refrain from bidding; and
- D. BIDDER has not engaged in corrupt, fraudulent, collusive, or coercive practices in competing for the Contract. For the purposes of this Paragraph 4.01.D:
 - 1. “corrupt practice” means the offering, giving, receiving, or soliciting of any thing of value likely to influence the action of a public official in the bidding process;
 - 2. “fraudulent practice” means an intentional misrepresentation of facts made (a) to influence the bidding process to the detriment of OWNER, (b) to establish bid prices at artificial non-competitive levels, or (c) to deprive OWNER of the benefits of free and open competition;
 - 3. “collusive practice” means a scheme or arrangement between two or more BIDDERS, with or without the knowledge of OWNER, a purpose of which is to establish bid prices at artificial, non-competitive levels; and
 - 4. “coercive practice” means harming or threatening to harm, directly or indirectly, persons or their property to influence their participation in the bidding process or affect the execution of the Contract.

ARTICLE 5 – BASIS OF BID

- 5.01 BIDDER acknowledges that (1) each Bid Unit Price includes an amount considered by BIDDER to be adequate to cover CONTRACTOR’s overhead and profit for each separately identified item, and (2) estimated quantities are not guaranteed, and are solely for the purpose of comparison of Bids, and final payment for all unit price Bid items will be based on actual quantities, determined as provided in the Contract Documents. Unit Prices have been computed in accordance with Paragraph 13.03B of the General Conditions.
- 5.02 BIDDER will complete the Work in accordance with the Contract Documents for the following price(s):

**BID
SCHEDULE**

ALL BID ITEMS SHALL INCLUDE ALL COSTS FOR FURNISHING TO THE OWNER ALL MATERIALS, EQUIPMENT AND SUPPLIES, PERMITS, AND FOR ALL COSTS INCURRED IN PROVIDING ALL WORK SHOWN ON THE PROJECT DRAWINGS AND OUTLINED IN THE CONTRACT SPECIFICATIONS AND DOCUMENTS FOR THE CONSTRUCTION.

ITEM	DESCRIPTION	UNITS	QUANTITY	UNIT COST	TOTAL COST
LUMP SUM					
01	Contractor's Bonds and Insurance	LS	1	\$6,000.00	\$6,000.00
02	Mobilization and Demobilization	LS	1	\$5,720.00	\$5,720.00
03	Decking and Rub Rail Replacement	LS	1	\$6,673.00	\$6,673.00
UNIT COST					
04	Dock and Wave Fence	LF	122	\$775.41	\$94,600.02

TOTAL BASE BID (ITEMS 01 THRU 04) \$ **\$112,993.02**

TOTAL BASE BID (WRITTEN)

One Hundred Twelve Thousand Nine Hundred Ninety Three Dollars and Two Cents

Dollars

AMOUNTS SHALL BE SHOWN IN BOTH WORDS AND NUMBERS. IN CASE OF DISCREPANCIES, THE AMOUNT SHOWN IN WORDS SHALL GOVERN FOR EACH BID ITEM AND TOTAL BID.

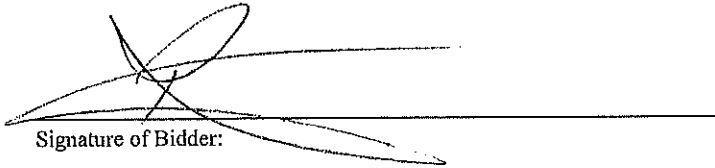
Signature of Bidder:

7/21/20
Date:

Notes:

- (1) Quantities are estimated. Actual quantities may vary.
- (1) All bids must be for the entire work and must have each blank space completed.

ARTICLE 9 – BID SUBMITTAL

Bidder: Indicate correct name of bidding entity:

Decks N Such Marine Inc.

By: Signature: [Handwritten Signature]

Printed name: Paul Hartzog

(If BIDDER is a corporation, a limited liability company, a partnership, or a joint venture, attach evidence of authority to sign.)

Attest: Signature: [Handwritten Signature]

Printed name: Kirk Franco

Title: Project Manager

Submittal Date: 07-22-2020

Address for giving notices:

Telephone Number: 850-314-0444

Fax Number: N/A

Contact Name: Paul Hartzog

Contact Phone Number: 850-240-3625

Contact Email Address: paul@ssd.gccoxmail.com, kfranco@dns.gccoxmail.com

Federal ID or SS Number: 59-3421521

Bidder's License No.: CGC1516044

DUNS Number: 945169233

CAGE Code: 079E6

DOCUMENT 00410 – ADDENDUM ACKNOWLEDGEMENT – ATTACHMENT “A”

Acknowledgement is hereby made of the following addenda (identified by number) received since issuance of solicitation:

ADDENDUM NUMBER	DATE
1	07/06/20
2	07/14/20

NOTE: Prior to submitting the response to this solicitation, it is the responsibility of the BIDDER to confirm if any addenda have been issued. If such addenda have been issued, acknowledge receipt by noting number(s) and date(s) above.

DOCUMENT 00410 – SCHEDULE OF SUBCONTRACTORS – ATTACHMENT “B”

Attachment “B” is not required to be submitted as part of the Bid Package as defined in Paragraph 11.02 of the Instructions to Bidders.

The following is a complete list of all subcontractors utilized for this project (if applicable):

- 1. NA NA
Company Name Type of Work
NA NA
Address Telephone Number
NA NA
City, State, Zip Federal ID Number
- 2. NA NA
Company Name Type of Work
NA NA
Address Telephone Number
NA NA
City, State, Zip Federal ID Number
- 3. NA NA
Company Name Type of Work
NA NA
Address Telephone Number
NA NA
City, State, Zip Federal ID Number
- 4. NA NA
Company Name Type of Work
NA NA
Address Telephone Number
NA NA
City, State, Zip Federal ID Number

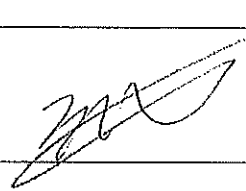
Authorized Signature: 

DOCUMENT 00410 – CONFLICT OF INTEREST DISCLOSURE – ATTACHMENT "C"

For purposes of determining any possible conflict of interest, all BIDDERS, must disclose if any Okaloosa Board of County commissioner, employee(s), elected official(s) or if any of its agencies is also an owner, corporate officer, agency, employee, etc., of their business.

Indicate either "YES" (a county employee, elected official or agency is also associated with your business) or "NO". If yes, give person(s) name(s) and position(s) with your business.

YES: _____ NO: X

NAME

POSITION

07/21/20
Date

Decks N Such Marine
Firm Name

PO Box 327 Fort Walton
Address

Beach, Fl 32548
Address

850-314-0444
Office Number

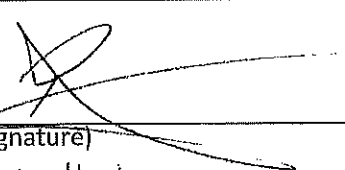
By (Signature)

Paul Hartzog
By (Printed)

President
Title

paul@ssd.cjccoxmail.com
Email

850-240-3625
Cell Number

DOCUMENT 00410 – RECYCLED CONTENT – ATTACHMENT "D"

1. Material: N/A

Is the above material: Virgin _____ Recycled _____ If recycled, what percentage _____ %

Describe: _____

Is the material packaged/shipped in packaging containing recycled content? Yes _____ No _____

If yes, specify packaging: _____

Is the material recyclable after it has reached the end of its intended use? Yes _____ No _____

If yes, explain: _____

2. Material: _____

Is the above material: Virgin _____ Recycled _____ If recycled, what percentage _____ %

Describe: _____

Is the material packaged/shipped in packaging containing recycled content? Yes _____ No _____

If yes, specify packaging: _____

Is the material recyclable after it has reached the end of its intended use? Yes _____ No _____

If yes, explain: _____

3. Material: _____

Is the above material: Virgin _____ Recycled _____ If recycled, what percentage _____ %

Describe: _____

Is the material packaged/shipped in packaging containing recycled content? Yes _____ No _____

If yes, specify packaging: _____

Is the material recyclable after it has reached the end of its intended use? Yes _____ No _____

If yes, explain: _____

DOCUMENT 00410 – DRUG-FREE WORKPLACE PROGRAM CERTIFICATION – ATTACHMENT “E”

THE BELOW SIGNED BIDDER CERTIFIES that it has implemented a drug-free workplace program. In order to have a drug free workplace program, a business shall:

1. Publish a statement notifying employees that the unlawful manufacture, distribution, dispensing, possession, or use of a controlled substance is prohibited in the workplace and specifying the actions that will be taken against employees for violations of such prohibition.
2. Inform employees about the dangers of drug abuse in the workplace, the business’s policy of maintaining a drug-free workplace, any available drug counseling, rehabilitation and employee assistance programs, and the penalties that may be imposed upon employees for drug abuse violations.
3. Give each employee engaged in providing the commodities or contractual services that are under quote a copy of the statement specified in subsection 1.
4. In the statement specified in subsection 1, notify the employees that, as a condition of working on the commodities or contractual services that are under quote, the employee will abide by the terms of the statement and will notify the employer of any conviction of, or plea of guilty or nolo contendere to, any violation of Chapter 893, Florida Statutes, or of any controlled substance law of the United States or any state, for a violation occurring in the workplace no later than five (5) days after such conviction.
5. Impose a sanction on, or require the satisfactory participation in, drug abuse assistance or rehabilitation program if such is available in employee’s community, by any employee who is convicted.
6. Make a good faith effort to continue to maintain a drug-free workplace through implementation of this section.

As the person authorized to sign this statement, I certify that this firm complies fully with the above requirements.

7/21/20
Date

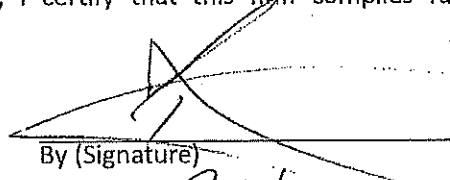
By (Signature)

Decks N Such Marine Inc.
Firm Name

Paul Hartzo
By (Printed)

PO Box 327 Fort Walton Beach 32548
Address

President
Title

Address

Paul@ssd.gccoxmail.com
Email

850-314-0444
Office Number

850-240-3625
Cell Number

DOCUMENT 00410 -- INDEMNIFICATION AND HOLD HARMLESS -- ATTACHMENT "F"

To the fullest extent permitted by law, CONTRACTOR shall indemnify and hold harmless the OWNER and the design Engineer, the officers and employees of each from liabilities, damages, losses and costs including but not limited to, reasonable attorney fees, to the extent caused by the negligence, recklessness or intentional wrongful conduct of the CONTRACTOR and other persons employed or utilized by the CONTRACTOR in the performance of this Agreement.

7/21/20
Date

Decks N Such Marine Inc.
Firm Name

PO Box 327, Fort Walton Beach
Address

Florida, 32548
Address

850-314-0444
Office Number

NA
Fax Number

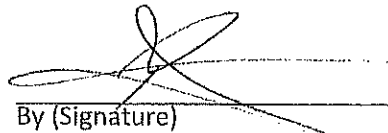
By (Signature)

Paul Hurtzou
By (Printed)

President
Title

paul@ssd.gccoxmail.com
Email

850-240-3625
Cell Number

850-240-3625
After-Hour Number(s)

DOCUMENT 00410 – INSURANCE COMPLIANCE CERTIFICATION – ATTACHMENT "G"

This form is to be completed and signed by you certifying that your policy either meets the insurance requirements as specified in Bid No. ITB PW 49-20 or that the insurance company has reviewed the bid requirements and certifies that you were quoted any price increase due to required coverage.

I certify that the insurance requirements have been reviewed.

7/21/20
Date

Decks N Such Marine
Firm Name

PO Box 327 Fort Walton Beach
Address

FL 32548
Address

850-314-0444
Office Number

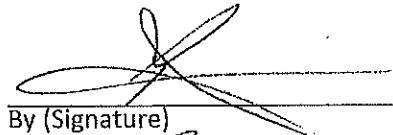
By (Signature)

~~President~~ Paul Hartman
By (Printed)

President
Title

Paul@ssol.gcc or mail.com
Email

850-240-3625
Cell Number

DOCUMENT 00410 – CONE OF SILENCE CLAUSE – ATTACHMENT "H"

The Board of County Commissioners has established a solicitation silence policy (**Cone of Silence**) that prohibits oral and written communication regarding all formal solicitations for goods and services (ITB, RFP, ITQ, ITN, and RFQ) or other competitive solicitation between the bidder (or its agents or representatives) or other entity with the potential for a financial interest in the award (or their respective agents or representatives) regarding such competitive solicitation, and any County Commissioner or County employee, selection committee member or other persons authorized to act on behalf of the Board including the County's Architect, Engineer or their subconsultants, or anyone designated to provide a recommendation to award a particular contract, other than the Purchasing Department Staff.

The period commences from the time of advertisement until contract award.

Any information thought to affect the committee or staff recommendation submitted after bids are due, should be directed to the Purchasing Director or an appointed representative. It shall be the Purchasing Director's decision whether to consider this information in the decision process.

Any violation of this policy shall be grounds to disqualify the bidder from consideration during the selection process.

All bidders must agree to comply with this policy by signing the following statement and including it with their submittal.

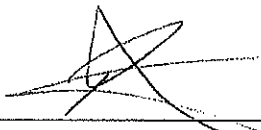
I,  _____, representing Decker N. Seck Marine Inc.
Signature Company Name

On this 21st day of July, 2020 hereby agree to abide by the County's "Cone of Silence Clause" and understand violation of this policy shall result in disqualification of my proposal/submittal.

DOCUMENT 00410 – FEDERAL E-VERIFY COMPLIANCE CERTIFICATION – ATTACHMENT "1"

In accordance with Okaloosa County Policy and Executive Order Number 11-116 from the office of the Governor of the State of Florida, BIDDER hereby certifies that the U.S. Department of Homeland Security's E-Verify system will be used to verify the employment eligibility of all new employees hired by the BIDDER during the contract term, and shall expressly require any subcontractors performing work or providing services pursuant to the contract to likewise utilize the U.S. Department of Homeland Securities E-Verify system to verify the employment of all new employees hired by the subcontractor during the contract term; and shall provide documentation of such verification to the COUNTY upon request.

As the person authorized to sign this statement, I certify that this company complies/will comply fully with the above requirements.

7/21/20
Date

Decks N Such Marine Inc.
Firm Name

PO Box 327 Fort Walton Beach, FL 32548
Address

Address
850-314-0444
Office Number

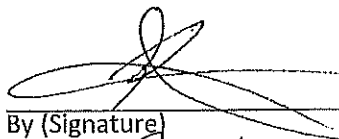
By (Signature)

Paul Herzog
By (Printed)

President
Title

paul@ssd.gccoxmail.com
Email

850-240-3625
Cell Number

DOCUMENT 00410 – CERTIFICATION REGARDING CHILD LABOR – ATTACHMENT "J"

In accordance with solicitation provision 45 CFR 22.15, BIDDER hereby certifies the review of the "List of Products Requiring Contractor Certification or Indentured Child Labor" as published by the Department of Labor in accordance with Executive Order 13126 of June 12, 1999 if any end products are used within this Contract as required by the Prohibition of Acquisition of Products Produced by Forced or Indentured Child Labor, 48 CFR 52.222-18. The list identifies products by their country of origin that the Departments of Labor, Treasury and State have a reasonable basis to believe might have been mined, produced or manufactured by forced or indentured child labor. (www.dol.gov/ilab/) see (22.1505(a))

The BIDDER certifies that they have made a good faith effort to determine whether forced or indentured child labor was used to mine, produce, or manufacture as listed for that end product. On the basis of those efforts, the BIDDER certifies that it is not aware of any such use of child labor. Specifically, any electrical equipment is not allowed from China per ORCA Certification 52.222-18.

As the person authorized to sign this statement, I certify that this company complies/will comply fully with the above requirements.

7/21/20
Date

Decks N Such Marine
Firm Name

PO Box 327 Fort Walton Beach, FL 32548
Address

Address

850-314-0444
Office Number

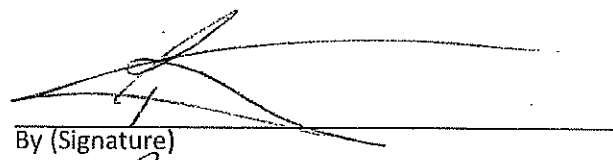

By (Signature)
Paul Hertson
By (Printed)

President
Title

Paul @ ssd.gccox mail.com
Email

850-240-3625
Cell Number

DOCUMENT 00410 – ANTI-COLLUSION STATEMENT – ATTACHMENT “K”

The below signed BIDDER has not divulged to, discussed or compared his bid with other BIDDERS and has not colluded with any other BIDDER or parties to bid whatever. (Note: No premiums, rebates or gratuities permitted either with, prior to, or after any delivery of materials.) Any such violation will result in the cancellation and/or return of material (as applicable) and the removal from bid list(s).

7/21/20
Date

Decks N Such Marine
Firm Name

PO Box 327 FWB, FL 32548
Address

Address

850-314-0444
Office Number

By (Signature)

Paul Hartzoey
By (Printed)

President
Title

Paul@ssd.gccoxmail.com
Email

850-240-3625
Cell Number

DOCUMENT 00410 – COMPANY DATA – ATTACHMENT "L"

Bidder's Company Name: Decks N Such Marine

Physical Address: 787 Boulevard of the Champions Shalimar, FL 32579

Contact Person (printed): Paul Hartzong

Phone Number: 850-314-0444 Fax Number: NA

Cell Number: 850-240-3625

Email: paul@ssd.gccoxmail.com

Federal ID or SS Number: 59-3421521

Bidder's License Number: CGC1516044

Emergency After-Hours,
Weekend or Holiday Contact
with Number: 850-240-3625

DOCUMENT 00410 - LIST OF REFERENCES - ATTACHMENT "M"

1. Seascape Towns Center
Company Name

100 Seascape Drive
Address

Miramar Beach, Fl. 32550
City, State, Zip

Jay Nettos
Contact Person

850-837-9181
Telephone Number

Nettos@seascape-resort.com
Email

2. Adventure Marina
Company Name

1201 Miracle Strip Parkway, S.E.
Address

Fort Walton Beach, Fl., 32548
City, State, Zip

Amanda Roberts
Contact Person

850-581-2628
Telephone Number

amanda@adventuremarina.com
Email

3. Eglin AFB / Hurlburt Field
Company Name

Postal Point
Address

Eglin Air Force Base, 32542
City, State, Zip

Brent Knapp
Contact Person

850-240-6470
Telephone Number

brent.knapp.1@us.af.mil
Email

DOCUMENT 00410 – VENDORS ON SCRUTINIZED COMPANIES LISTS – ATTACHMENT “N”

By executing this Certificate Decks N Such Marine, Inc., the bid proposer, certifies that it is not: (1) listed on the Scrutinized Companies that Boycott Israel List, created pursuant to section 215.4725, Florida Statutes, (2) engaged in a boycott of Israel, (3) listed on the Scrutinized Companies with Activities in Sudan List or the Scrutinized Companies with Activities in the Iran Petroleum Energy Sector List, created pursuant to section 215.473, Florida Statutes, or (4) engaged in business operations in Cuba or Syria. Pursuant to section 287.135(5), Florida Statutes, the County may disqualify the bid proper immediately or immediately terminate any agreement entered into for cause if the bid proposer is found to have submitted a false certification as to the above or if the Contractor is placed on the Scrutinized Companies that Boycott Israel List, is engaged in a boycott of Israel, has been placed on the Scrutinized Companies with Activities in Sudan List or the Scrutinized Companies with Activities in the Iran Petroleum Energy Sector List, or has been engaged in business operations in Cuba or Syria, during the term of the Agreement. If the County determines that the bid proposer has submitted a false certification, the County will provide written notice to the bid proposer. Unless the bid proposer demonstrates in writing, within 90 calendar days of receipt of the notice, that the County’s determination of false certification was made in error, the County shall bring a civil action against the bid proposer. If the County’s determination is upheld, a civil penalty shall apply, and the bid proposer will be ineligible to bid on any Agreement with a Florida agency or local governmental entity for three years after the date of County’s determination of false certification by bid proposer.

As the person authorized to sign this statement, I certify that this firm complies fully with the above requirements.

DATE: 7/21/20

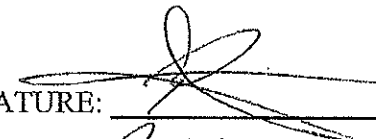
SIGNATURE: 

COMPANY: Decks N Such Marine Inc.

NAME: Paul Hartog
(Typed or Printed)

ADDRESS: PO Box 327 FWB,
FL 32548

TITLE: President

E-MAIL: Paul@ssdiggccoxmail.com

PHONE NO.: 850-314-0444

DOCUMENT 00410 – CERTIFICATION REGARDING LOBBYING – ATTACHMENT "O"

31 U.S.C. 1352, 49 CFR 19, 49 CFR PART 20
APPENDIX A, 49 CFR PART 20

Certification for Contracts, Grants, Loans and Cooperative Agreements (to be submitted with each bid or offer exceeding \$100,000)

The undersigned CONTRACTOR certifies, to the best of his/her knowledge and belief, that:

1. No Federal appropriated funds have been paid or will be paid, by or on behalf of the undersigned, to any person for influencing or attempting to influence an officer or employee of an agency, a Member of Congress, an officer or employee of Congress, or an employee of a Member of Congress in connection with the awarding of any Federal contract, the making of any Federal grant, the making of any Federal loan, the entering into of any cooperative agreement, and the extension, continuation, renewal, amendment or modification of any Federal contract, grant, loan or cooperative agreement.
2. If any funds other than Federal appropriated funds have been paid or will be paid to any person for making lobbying contacts to an officer or employee of any agency, a Member of Congress, an officer or employee of Congress, or an employee of a Member of Congress in connection with this Federal contract, grant, loan, or cooperative agreement, the undersigned shall complete and submit Standard Form--LLL, "Disclosure Form to Report Lobbying," in accordance with its instructions [as amended by "government wide Guidance for New Restrictions on Lobbying," 61 Fed. Reg. 1413 (1/19/96). Note: Language in paragraph (2) herein has been modified in accordance with Section 10 of the Lobbying Disclosure Act of 1995 (P.L. 104-65, to be codified at 2 U.S.C. 1601, et seq.)]
3. The undersigned shall require that the language of this certification be included in the award documents for all subawards at all tiers (including subcontracts, subgrants, and contracts under grants, loans and cooperative agreements) and that all subrecipients shall certify and disclose accordingly.

This certification is a material representation of fact upon which reliance was placed when this transaction was made or entered into. Submission of this certification is a prerequisite for making or entering into this transaction imposed by 31 U.S.C. 1352 (as amended by the Lobbying Disclosure Act of 1995). Any person who fails to file the required certification shall be subject to civil penalty of not less than \$10,000 and not more than \$100,000 for each such failure.

[Note: Pursuant to 31 U.S.C. 1352(c)(1)-(2)A, any person who makes a prohibited expenditure or fails to file or amend a required certification or disclosure form shall be subject to a civil penalty of not less than \$10,000 and not more than \$100,000 for each such expenditure or failure.]

The Contractor, Decks N Such Marine, certifies or affirms the truthfulness and accuracy of each statement of its certification and disclosure, if any. In addition, the Contractor understands and agrees that the provisions of 31 U.S.C. A 3801, et seq., apply to this certification and disclosure, if any.

7/21/20
Date

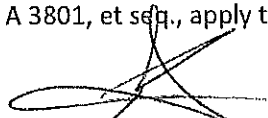
By (Signature)

Decks N Such Marine
Firm Name

President
Title

END OF DOCUMENT 00410 – BID FORM WITH ATTACHMENTS

DOCUMENT 00610 – PERFORMANCE BOND

CONTRACTOR (name and address):

Decks N Such Marine, Inc.
P.O. Box 327
Fort Walton Beach, FL 32549

SURETY (name and address of principal place of business):

United Casualty & Surety Insurance Company
292 Newbury St. #105
Boston, MA 02115-2801

OWNER (name and address): Okaloosa Board of County Commissioners
1250 N. Eglin Parkway
Shalimar, FL 32579

CONSTRUCTION CONTRACT

Effective Date of the Agreement: September 24, 2020
Amount: One Hundred Twelve Thousand, Nine Hundred Ninety-Three and 02/100 Dollars (\$112,993.02)
Description (name and location): Longwood / Poquito Bayou Park Dock Extension, Shalimar, Florida

BOND

Bond Number: UCSX372X3279
Date (not earlier than the Effective Date of the Agreement of the Construction Contract): October 23, 2020
Amount: One Hundred Twelve Thousand, Nine Hundred Ninety-Three and 02/100 Dollars (\$112,993.02)
Modifications to this Bond Form: [X] None [] See Paragraph 16

Surety and Contractor, intending to be legally bound hereby, subject to the terms set forth below, do each cause this Performance Bond to be duly executed by an authorized officer, agent, or representative.

CONTRACTOR AS PRINCIPAL
Decks N Such Marine, Inc. (seal)
Contractor's Name and Corporate Seal

By: [Signature]
Signature
Paul Hartzog
Print Name

President/Owner
Title

Attest: [Signature]
Signature

Project Manager
Title

SURETY
United Casualty & Surety Insurance Company (seal)
Surety's Name and Corporate Seal

By: [Signature]
Signature (attach power of attorney)
Kelly A. Specht
Print Name

Attorney-in-Fact
Title

Attest: [Signature]
Signature

Account Manager
Title

Notes: (1) Provide supplemental execution by any additional parties, such as joint venturers. (2) Any singular reference to Contractor, Surety, Owner, or other party shall be considered plural where applicable.

1. The Contractor and Surety, jointly and severally, bind themselves, their heirs, executors, administrators, successors, and assigns to the Owner for the performance of the Construction Contract, which is incorporated herein by reference.

2. If the Contractor performs the Construction Contract, the Surety and the Contractor shall have no obligation under this Bond, except when applicable to participate in a conference as provided in Paragraph 3.

3. If there is no Owner Default under the Construction Contract, the Surety's obligation under this Bond shall arise after:

3.1 The Owner first provides notice to the Contractor and the Surety that the Owner is considering declaring a Contractor Default. Such notice shall indicate whether the Owner is requesting a conference among the Owner, Contractor, and Surety to discuss the Contractor's performance. If the Owner does not request a conference, the Surety may, within five (5) business days after receipt of the Owner's notice, request such a conference. If the Surety timely requests a conference, the Owner shall attend. Unless the Owner agrees otherwise, any conference requested under this Paragraph 3.1 shall be held within ten (10) business days of the Surety's receipt of the Owner's notice. If the Owner, the Contractor, and the Surety agree, the Contractor shall be allowed a reasonable time to perform the Construction Contract, but such an agreement shall not waive the Owner's right, if any, subsequently to declare a Contractor Default;

3.2 The Owner declares a Contractor Default, terminates the Construction Contract and notifies the Surety; and

3.3 The Owner has agreed to pay the Balance of the Contract Price in accordance with the terms of the Construction Contract to the Surety or to a contractor selected to perform the Construction Contract.

4. Failure on the part of the Owner to comply with the notice requirement in Paragraph 3.1 shall not constitute a failure to comply with a condition precedent to the Surety's obligations, or release the Surety from its obligations, except to the extent the Surety demonstrates actual prejudice.

5. When the Owner has satisfied the conditions of Paragraph 3, the Surety shall promptly and at the Surety's expense take one of the following actions:

5.1 Arrange for the Contractor, with the consent of the Owner, to perform and complete the Construction Contract;

5.2 Undertake to perform and complete the Construction Contract itself, through its agents or independent contractors;

5.3 Obtain bids or negotiated proposals from qualified contractors acceptable to the Owner for a contract for performance and completion of the Construction Contract, arrange for a contract to be prepared for execution by the Owner and a contractor selected with the Owner's concurrence, to be secured with performance and payment bonds executed by a qualified surety equivalent to the bonds issued on the Construction Contract, and pay to the Owner the amount of damages as described in Paragraph 7 in excess of the Balance of the Contract Price incurred by the Owner as a result of the Contractor Default; or

5.4 Waive its right to perform and complete, arrange for completion, or obtain a new contractor, and with reasonable promptness under the circumstances:

5.4.1 After investigation, determine the amount for which it may be liable to the Owner and, as soon as practicable after the amount is determined, make payment to the Owner; or

5.4.2 Deny liability in whole or in part and notify the Owner, citing the reasons for denial.

6. If the Surety does not proceed as provided in Paragraph 5 with reasonable promptness, the Surety shall be deemed to be in default on this Bond seven days after receipt of an additional written notice from the Owner to the Surety demanding that the Surety perform its obligations under this Bond, and the Owner shall be entitled to enforce any remedy available to the Owner. If the Surety proceeds as provided in Paragraph 5.4, and the Owner refuses the payment or the Surety has denied liability, in whole or in part, without further notice the Owner shall be entitled to enforce any remedy available to the Owner.

7. If the Surety elects to act under Paragraph 5.1, 5.2, or 5.3, then the responsibilities of the Surety to the Owner shall not be greater than those of the Contractor under the Construction Contract, and the responsibilities of the Owner to the Surety shall not be greater than those of the Owner under the Construction Contract. Subject to the commitment by the Owner to pay the Balance of the Contract Price, the Surety is obligated, without duplication for:

7.1 the responsibilities of the Contractor for correction of defective work and completion of the Construction Contract;

7.2 additional legal, design professional, and delay costs resulting from the Contractor's Default, and resulting from the actions or failure to act of the Surety under Paragraph 5; and

7.3 liquidated damages, or if no liquidated damages are specified in the Construction Contract, actual damages caused by delayed performance or non-performance of the Contractor.

8. If the Surety elects to act under Paragraph 5.1, 5.3, or 5.4, the Surety's liability is limited to the amount of this Bond.

9. The Surety shall not be liable to the Owner or others for obligations of the Contractor that are unrelated to the Construction Contract, and the Balance of the Contract Price shall not be reduced or set off on account of any such unrelated obligations. No right of action shall accrue on this Bond to any person or entity other than the Owner or its heirs, executors, administrators, successors, and assigns.

10. The Surety hereby waives notice of any change, including changes of time, to the Construction Contract or to related subcontracts, purchase orders, and other obligations.

11. Any proceeding, legal or equitable, under this Bond may be instituted in any court of competent jurisdiction in the location in which the work or part of the work is located and shall be instituted within two years after a declaration of Contractor Default or within two years after the Contractor ceased working or within two years after the Surety refuses or fails to perform its obligations under this Bond, whichever occurs first. If the provisions of this paragraph are void or prohibited by law, the minimum periods of limitations available to sureties as a defense in the jurisdiction of the suit shall be applicable.

12. Notice to the Surety, the Owner, or the Contractor shall be mailed or delivered to the address shown on the page on which their signature appears.

13. When this Bond has been furnished to comply with a statutory or other legal requirement in the location where the construction was to be performed, any provision in this Bond conflicting with said statutory or legal requirement shall be deemed deleted herefrom and provisions conforming to such statutory or other legal requirement shall be deemed incorporated herein. When so furnished, the intent is that this

Bond shall be construed as a statutory bond and not as a common law bond.

14. Definitions

14.1 Balance of the Contract Price: The total amount payable by the Owner to the Contractor under the Construction Contract after all proper adjustments have been made including allowance for the Contractor for any amounts received or to be received by the Owner in settlement of insurance or other claims for damages to which the Contractor is entitled, reduced by all valid and proper payments made to or on behalf of the Contractor under the Construction Contract.

14.2 Construction Contract: The agreement between the Owner and Contractor identified on the cover page, including all Contract Documents and changes made to the agreement and the Contract Documents.

14.3 Contractor Default: Failure of the Contractor, which has not been remedied or waived, to perform or otherwise to comply with a material term of the Construction Contract.

14.4 Owner Default: Failure of the Owner, which has not been remedied or waived, to pay the Contractor as required under the Construction Contract or to perform and complete or comply with the other material terms of the Construction Contract.

14.5 Contract Documents: All the documents that comprise the agreement between the Owner and Contractor.

15. If this Bond is Issued for an agreement between a contractor and subcontractor, the term Contractor in this Bond shall be deemed to be Subcontractor and the term Owner shall be deemed to be Contractor.

16. Modifications to this Bond are as follows:

END OF DOCUMENT 00610 – PERFORMANCE BOND

California All-Purpose Certificate of Acknowledgment

A notary public or other officer completing this certificate verifies only the identity of the individual who signed the document to which this certificate is attached, and not the truthfulness, accuracy, or validity of that document.

State of California

County of Orange

s.s.

On October 23, 2020 before me, Bethany Mercer, Notary Public

Name of Notary Public, Title

personally appeared Kelly A. Specht

Name of Signer (1)

Name of Signer (2)

who proved to me on the basis of satisfactory evidence to be the person(s) whose name(s) is/are subscribed to the within instrument and acknowledged to me that he/she/they executed the same in his/her/their authorized capacity(ies), and that by his/her/their signature(s) on the instrument the person(s), or the entity upon behalf of which the person(s) acted, executed the instrument.

I certify under PENALTY OF PERJURY under the laws of the State of California that the foregoing paragraph is true and correct.

WITNESS my hand and official seal.

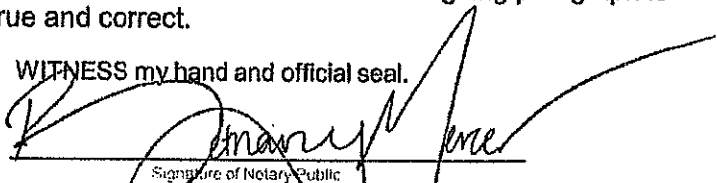
Signature of Notary Public



Seal

OPTIONAL INFORMATION

Although the information in this section is not required by law, it could prevent fraudulent removal and reattachment of this acknowledgment to an unauthorized document and may prove useful to persons relying on the attached document.

Description of Attached Document

The preceding Certificate of Acknowledgment is attached to a document titled/for the purpose of _____

Performance Bond#UCSX372X3279

containing 3 pages, and dated October 23, 2020

The signer(s) capacity or authority is/are as:

- Individual(s)
 Attorney-in-fact
 Corporate Officer(s) _____

Title(s)

- Guardian/Conservator
 Partner - Limited/General
 Trustee(s)
 Other: _____

representing: United Casualty and Surety Insurance Company

(As Agent of Principal(s) Party(ies) Signer is Representing)

Additional Information

Method of Signer Identification

Proved to me on the basis of satisfactory evidence:

- form(s) of identification credible witness(es)

Notarial event is detailed in notary journal on:

Page # _____ Entry # _____

Notary contact: _____

Other

- Additional Signer Signer(s) Thumbprints(s)



UNITED CASUALTY AND SURETY INSURANCE COMPANY
 US Casualty and Surety Insurance Company
 United Surety Insurance Company

POWER OF ATTORNEY

Agency No. 171372

KNOW ALL MEN BY THESE PRESENTS: That United Casualty and Surety Insurance Company, a corporation of the State of Nebraska, and US Casualty and Surety Insurance Company and United Surety Insurance Company, assumed names of United Casualty and Surety Insurance Company (collectively, the Companies), do by these presents make, constitute and appoint:

Kelly A. Specht, Kandis Gregory, Richard P. Ford, Thomas C. Buckner, Michael Herranen, Bethany Mercer

Its true and lawful Attorney(s)-In-Fact, each in their separate capacity if more than one is named above, with full power and authority hereby conferred in its name, place and stead, to execute, acknowledge and deliver any and all bonds, recognizances, undertakings or other instruments or contracts of suretyship to include riders, amendments, and consents of surety. This Power of Attorney shall expire without further action on December 31st, 2023.

This Power of Attorney is granted under and by authority of the following resolutions adopted by the Board of Directors of the Companies at a meeting duly called and held on the 1st day of July, 1993:

Resolved that the President, Treasurer, or Secretary be and they are hereby authorized and empowered to appoint Attorneys-In-Fact of the Company, in its name and as its acts to execute and acknowledge for and on its behalf as Surety any and all bonds, recognizances, contracts of indemnity, waivers of citation and all other writings obligatory in the nature thereof, with power to attach thereto the seal of the Company. Any such writings so executed by such Attorneys-In-Fact shall be binding upon the Company as if they had been duly executed and acknowledged by the regularly elected Officers of the Company in their own proper persons.

That the signature of any officer authorized by Resolutions of this Board and the Company seal may be affixed by facsimile to any power of attorney or special power of attorney or certification of either given for the execution of any bond, undertaking, recognizance or other written obligation in the nature thereof; such signature and seal, when so used being hereby adopted by the Company as the original signature of such officer and the original seal of the Company, to be valid and binding upon the Company with the same force and effect as though manually affixed.

IN WITNESS WHEREOF, the Companies have caused this instrument to be signed and their corporate seals to be hereunto affixed, this 1st day of August, 2019.

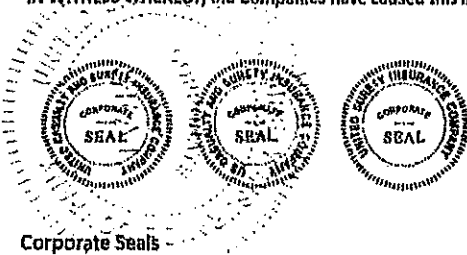

UNITED CASUALTY AND SURETY INSURANCE COMPANY
 US Casualty and Surety Insurance Company
 United Surety Insurance Company

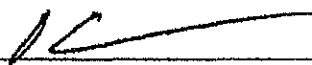

 Joel R. Chachkes, Treasurer

Commonwealth of Massachusetts
 County of Suffolk ss:

On this 1st day of August, 2019, before me, Thomas P. Carrigan, Jr., a notary public, personally appeared Joel R. Chachkes, Treasurer of United Casualty and Surety Insurance Company, US Casualty and Surety Insurance Company and United Surety Insurance Company, who proved to me on the basis of satisfactory evidence to be the person whose name is subscribed to the within instrument and acknowledged to me that he executed the same in his authorized capacity, and that by his signature on the instrument the person(s), or the entity on behalf of which the person(s) acted, executed the instrument.

I certify under PENALTY OF PERJURY under the laws of the Commonwealth of Massachusetts that the foregoing paragraph is true and correct.
 WITNESS my hand and seal.

 _____ (Seal)
 Thomas P. Carrigan, Jr., Notary Public Commission Expires: 10/31/2025

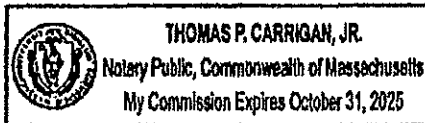

I, Robert F. Thomas, Chief Operating Officer of United Casualty and Surety Insurance Company, US Casualty and Surety Insurance Company and United Surety Insurance Company do hereby certify that the above and foregoing is a true and correct copy of a Power of Attorney, executed by said Companies, which is still in full force and effect; furthermore, the resolutions of the Board of Directors, set out in the Power of Attorney are in full force and effect.

In Witness Whereof, I have hereunto set my hand and affixed the seals of said Companies at Boston, Massachusetts this 23rd day of October, 2020.





 Robert F. Thomas, Chief Operating Officer

DOCUMENT 00620 -- PAYMENT BOND

CONTRACTOR (name and address):

Decks N Such Marine, Inc.
P.O. Box 327
Fort Walton Beach, FL 32549

SURETY (name and address of principal place of business):

United Casualty & Surety Insurance Company
292 Newbury St. #105
Boston, MA 02115-2801

OWNER (name and address): Okaloosa Board of County Commissioners
1250 N. Eglin Parkway
Shalimar, FL 32579

CONSTRUCTION CONTRACT

Effective Date of the Agreement: September 24, 2020
Amount: One Hundred Twelve Thousand, Nine Hundred Ninety-Three and 02/100 Dollars (\$112,993.02)
Description (name and location): Longwood / Poquito Bayou Park Dock Extension, Shalimar, Florida

BOND

Bond Number: UCSX372X3279
Date (not earlier than the Effective Date of the Agreement of the Construction Contract): October 23, 2020
Amount: One Hundred Twelve Thousand, Nine Hundred Ninety-Three and 02/100 Dollars (\$112,993.02)
Modifications to this Bond Form: [X] None [] See Paragraph 18

Surety and Contractor, intending to be legally bound hereby, subject to the terms set forth below, do each cause this Payment Bond to be duly executed by an authorized officer, agent, or representative.

CONTRACTOR AS PRINCIPAL

Decks N Such Marine, Inc. (seal)
Contractor's Name and Corporate Seal

By: [Signature]
Signature

Paul Hartzog
Print Name

President/Owner
Title

Attest: [Signature]
Signature

Project Manager
Title

SURETY

United Casualty & Surety Insurance Company (seal)
Surety's Name and Corporate Seal

By: Kelly A. Specht
Signature (attach power of attorney)

Kelly A. Specht
Print Name

Attorney-in-Fact
Title

Attest: [Signature]
Signature

Account Manager
Title

Notes: (1) Provide supplemental execution by any additional parties, such as joint venturers. (2) Any singular reference to Contractor, Surety, Owner, or other party shall be considered plural where applicable.

1. The Contractor and Surety, jointly and severally, bind themselves, their heirs, executors, administrators, successors, and assigns to the Owner to pay for labor, materials, and equipment furnished for use in the performance of the Construction Contract, which is incorporated herein by reference, subject to the following terms.

2. If the Contractor promptly makes payment of all sums due to Claimants, and defends, indemnifies, and holds harmless the Owner from claims, demands, liens, or suits by any person or entity seeking payment for labor, materials, or equipment furnished for use in the performance of the Construction Contract, then the Surety and the Contractor shall have no obligation under this Bond.

3. If there is no Owner Default under the Construction Contract, the Surety's obligation to the Owner under this Bond shall arise after the Owner has promptly notified the Contractor and the Surety (at the address described in Paragraph 13) of claims, demands, liens, or suits against the Owner or the Owner's property by any person or entity seeking payment for labor, materials, or equipment furnished for use in the performance of the Construction Contract, and tendered defense of such claims, demands, liens, or suits to the Contractor and the Surety.

4. When the Owner has satisfied the conditions in Paragraph 3, the Surety shall promptly and at the Surety's expense defend, indemnify, and hold harmless the Owner against a duly tendered claim, demand, lien, or suit.

5. The Surety's obligations to a Claimant under this Bond shall arise after the following:

5.1 Claimants who do not have a direct contract with the Contractor,

5.1.1 have furnished a written notice of non-payment to the Contractor, stating with substantial accuracy the amount claimed and the name of the party to whom the materials were, or equipment was, furnished or supplied or for whom the labor was done or performed, within ninety (90) days after having last performed labor or last furnished materials or equipment included in the Claim; and

5.1.2 have sent a Claim to the Surety (at the address described in Paragraph 13).

5.2 Claimants who are employed by or have a direct contract with the Contractor have sent a Claim to the Surety (at the address described in Paragraph 13).

6. If a notice of non-payment required by Paragraph 5.1.1 is given by the Owner to the Contractor, that is sufficient to satisfy a Claimant's obligation to furnish a written notice of non-payment under Paragraph 5.1.1.

7. When a Claimant has satisfied the conditions of Paragraph 5.1 or 5.2, whichever is applicable, the Surety shall promptly and at the Surety's expense take the following actions:

7.1 Send an answer to the Claimant, with a copy to the Owner, within sixty (60) days after receipt of the Claim, stating the amounts that are undisputed and the basis for challenging any amounts that are disputed; and

7.2 Pay or arrange for payment of any undisputed amounts.

7.3 The Surety's failure to discharge its obligations under Paragraph 7.1 or 7.2 shall not be deemed to constitute a waiver

of defenses the Surety or Contractor may have or acquire as to a Claim, except as to undisputed amounts for which the Surety and Claimant have reached agreement. If, however, the Surety fails to discharge its obligations under Paragraph 7.1 or 7.2, the Surety shall indemnify the Claimant for the reasonable attorney's fees the Claimant incurs thereafter to recover any sums found to be due and owing to the Claimant.

8. The Surety's total obligation shall not exceed the amount of this Bond, plus the amount of reasonable attorney's fees provided under Paragraph 7.3, and the amount of this Bond shall be credited for any payments made in good faith by the Surety.

9. Amounts owed by the Owner to the Contractor under the Construction Contract shall be used for the performance of the Construction Contract and to satisfy claims, if any, under any construction performance bond. By the Contractor furnishing and the Owner accepting this Bond, they agree that all funds earned by the Contractor in the performance of the Construction Contract are dedicated to satisfy obligations of the Contractor and Surety under this Bond, subject to the Owner's priority to use the funds for the completion of the work.

10. The Surety shall not be liable to the Owner, Claimants, or others for obligations of the Contractor that are unrelated to the Construction Contract. The Owner shall not be liable for the payment of any costs or expenses of any Claimant under this Bond, and shall have under this Bond no obligation to make payments to or give notice on behalf of Claimants, or otherwise have any obligations to Claimants under this Bond.

11. The Surety hereby waives notice of any change, including changes of time, to the Construction Contract or to related subcontracts, purchase orders, and other obligations.

12. No suit or action shall be commenced by a Claimant under this Bond other than in a court of competent jurisdiction in the state in which the project that is the subject of the Construction Contract is located or after the expiration of one year from the date (1) on which the Claimant sent a Claim to the Surety pursuant to Paragraph 5.1.2 or 5.2, or (2) on which the last labor or service was performed by anyone or the last materials or equipment were furnished by anyone under the Construction Contract, whichever of (1) or (2) first occurs. If the provisions of this paragraph are void or prohibited by law, the minimum period of limitation available to sureties as a defense in the jurisdiction of the suit shall be applicable.

13. Notice and Claims to the Surety, the Owner, or the Contractor shall be mailed or delivered to the address shown on the page on which their signature appears. Actual receipt of notice or Claims, however accomplished, shall be sufficient compliance as of the date received.

14. When this Bond has been furnished to comply with a statutory or other legal requirement in the location where the construction was to be performed, any provision in this Bond conflicting with said statutory or legal requirement shall be deemed deleted herefrom and provisions conforming to such statutory or other legal requirement shall be deemed incorporated herein. When so furnished, the intent is that this Bond shall be construed as a statutory bond and not as a common law bond.

15. Upon requests by any person or entity appearing to be a potential beneficiary of this Bond, the Contractor and Owner shall promptly furnish a copy of this Bond or shall permit a copy to be made.

16. Definitions

16.1 Claim: A written statement by the Claimant including at a minimum:

1. The name of the Claimant;
2. The name of the person for whom the labor was done, or materials or equipment furnished;
3. A copy of the agreement or purchase order pursuant to which labor, materials, or equipment was furnished for use in the performance of the Construction Contract;
4. A brief description of the labor, materials, or equipment furnished;
5. The date on which the Claimant last performed labor or last furnished materials or equipment for use in the performance of the Construction Contract;
6. The total amount earned by the Claimant for labor, materials, or equipment furnished as of the date of the Claim;
7. The total amount of previous payments received by the Claimant; and
8. The total amount due and unpaid to the Claimant for labor, materials, or equipment furnished as of the date of the Claim.

16.2 Claimant: An individual or entity having a direct contract with the Contractor or with a subcontractor of the Contractor to furnish labor, materials, or equipment for use in the performance of the Construction Contract. The term Claimant also includes any individual or entity that has rightfully asserted a claim under an applicable mechanic's lien or similar

statute against the real property upon which the Project is located. The Intent of this Bond shall be to include without limitation in the terms of "labor, materials, or equipment" that part of the water, gas, power, light, heat, oil, gasoline, telephone service, or rental equipment used in the Construction Contract, architectural and engineering services required for performance of the work of the Contractor and the Contractor's subcontractors, and all other items for which a mechanic's lien may be asserted in the jurisdiction where the labor, materials, or equipment were furnished.

16.3 Construction Contract: The agreement between the Owner and Contractor identified on the cover page, including all Contract Documents and all changes made to the agreement and the Contract Documents.

16.4 Owner Default: Failure of the Owner, which has not been remedied or waived, to pay the Contractor as required under the Construction Contract or to perform and complete or comply with the other material terms of the Construction Contract.

16.5 Contract Documents: All the documents that comprise the agreement between the Owner and Contractor.

17. If this Bond is issued for an agreement between a contractor and subcontractor, the term Contractor in this Bond shall be deemed to be Subcontractor and the term Owner shall be deemed to be Contractor.

18. Modifications to this Bond are as follows:

END OF DOCUMENT 00620 – PAYMENT BOND

California All-Purpose Certificate of Acknowledgment

A notary public or other officer completing this certificate verifies only the identity of the individual who signed the document to which this certificate is attached, and not the truthfulness, accuracy, or validity of that document.

State of California

County of Orange

s.s.

On October 23, 2020 before me, Bethany Mercer, Notary Public
Name of Notary Public, Title

personally appeared Kelly A. Specht
Name of Signer (1)

Name of Signer (2)

who proved to me on the basis of satisfactory evidence to be the person(s) whose name(s) is/are subscribed to the within instrument and acknowledged to me that he/she/they executed the same in his/her/their authorized capacity(ies), and that by his/her/their signature(s) on the instrument the person(s), or the entity upon behalf of which the person(s) acted, executed the instrument.

I certify under PENALTY OF PERJURY under the laws of the State of California that the foregoing paragraph is true and correct.

WITNESS my hand and official seal.

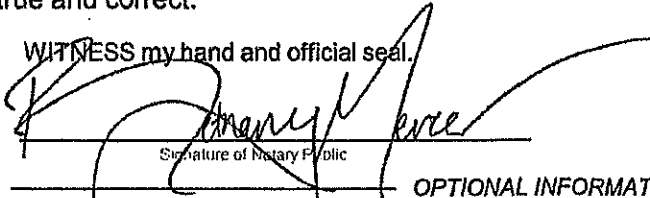
Signature of Notary Public



Seal

OPTIONAL INFORMATION

Although the information in this section is not required by law, it could prevent fraudulent removal and reattachment of this acknowledgment to an unauthorized document and may prove useful to persons relying on the attached document.

Description of Attached Document

The preceding Certificate of Acknowledgment is attached to a document titled/for the purpose of Payment Bond#UCSX372X3279

containing 3 pages, and dated October 23, 2020

The signer(s) capacity or authority is/are as:

- Individual(s)
 Attorney-in-fact
 Corporate Officer(s) _____
Title(s)

- Guardian/Conservator
 Partner - Limited/General
 Trustee(s)
 Other: _____

representing: United Casually and Surety Insurance Company
Name(s) of Person(s) Entitled to Signer's Representing

Additional Information

Method of Signer Identification

Proved to me on the basis of satisfactory evidence:

- form(s) of identification credible witness(es)

Notarial event is detailed in notary journal on:

Page # _____ Entry # _____

Notary contact: _____

Other

- Additional Signer Signer(s) Thumbprints(s)



UNITED CASUALTY AND SURETY INSURANCE COMPANY
 US Casualty and Surety Insurance Company
 United Surety Insurance Company

POWER OF ATTORNEY

Agency No. 171372

KNOW ALL MEN BY THESE PRESENTS: That United Casualty and Surety Insurance Company, a corporation of the State of Nebraska, and US Casualty and Surety Insurance Company and United Surety Insurance Company, assumed names of United Casualty and Surety Insurance Company (collectively, the Companies), do by these presents make, constitute and appoint:

Kelly A. Specht, Kandis Gregory, Richard P. Ford, Thomas C. Buckner, Michael Herranen, Bethany Mercer

Its true and lawful Attorney(s)-in-Fact, each in their separate capacity if more than one is named above, with full power and authority hereby conferred in its name, place and stead, to execute, acknowledge and deliver any and all bonds, recognizances, undertakings or other instruments or contracts of suretyship to include riders, amendments, and consents of surety. This Power of Attorney shall expire without further action on December 31st, 2023.

This Power of Attorney is granted under and by authority of the following resolutions adopted by the Board of Directors of the Companies at a meeting duly called and held on the 1st day of July, 1993:

Resolved that the President, Treasurer, or Secretary be and they are hereby authorized and empowered to appoint Attorneys-in-Fact of the Company, in its name and as its acts to execute and acknowledge for and on its behalf as Surety any and all bonds, recognizances, contracts of Indemnity, waivers of citation and all other writings obligatory in the nature thereof, with power to attach thereto the seal of the Company. Any such writings so executed by such Attorneys-in-Fact shall be binding upon the Company as if they had been duly executed and acknowledged by the regularly elected Officers of the Company in their own proper persons.

That the signature of any officer authorized by Resolutions of this Board and the Company seal may be affixed by facsimile to any power of attorney or special power of attorney or certification of either given for the execution of any bond, undertaking, recognizance or other written obligation in the nature thereof; such signature and seal, when so used being hereby adopted by the Company as the original signature of such officer and the original seal of the Company, to be valid and binding upon the Company with the same force and effect as though manually affixed.

IN WITNESS WHEREOF, the Companies have caused this instrument to be signed and their corporate seals to be hereunto affixed, this 1st day of August, 2019.

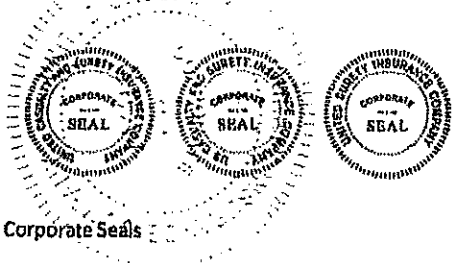

UNITED CASUALTY AND SURETY INSURANCE COMPANY
 US Casualty and Surety Insurance Company
 United Surety Insurance Company

 Joel R. Chachkes, Treasurer

Commonwealth of Massachusetts
 County of Suffolk ss:

On this 1st day of August, 2019, before me, Thomas P. Carrigan, Jr., a notary public, personally appeared Joel R. Chachkes, Treasurer of United Casualty and Surety Insurance Company, US Casualty and Surety Insurance Company and United Surety Insurance Company, who proved to me on the basis of satisfactory evidence to be the person whose name is subscribed to the within instrument and acknowledged to me that he executed the same in his authorized capacity, and that by his signature on the instrument the person(s), or the entity on behalf of which the person(s) acted, executed the instrument.

I certify under PENALTY OF PERJURY under the laws of the Commonwealth of Massachusetts that the foregoing paragraph is true and correct.
 WITNESS my hand and seal.

_____ (Seal)
 Thomas P. Carrigan, Jr., Notary Public Commission Expires: 10/31/2025

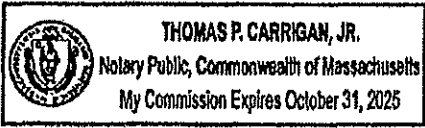

I, Robert F. Thomas, Chief Operating Officer of United Casualty and Surety Insurance Company, US Casualty and Surety Insurance Company and United Surety Insurance Company do hereby certify that the above and foregoing is a true and correct copy of a Power of Attorney, executed by said Companies, which is still in full force and effect; furthermore, the resolutions of the Board of Directors, set out in the Power of Attorney are in full force and effect.

In Witness Whereof, I have hereunto set my hand and affixed the seals of said Companies at Boston, Massachusetts this 23rd day of October, 2020.



 Robert F. Thomas, Chief Operating Officer

DOCUMENT 00700 – GENERAL CONDITIONS

This document has important legal consequences; consultation with an attorney is encouraged with respect to its use or modification. This document should be adapted to the particular circumstances of the contemplated Project and the controlling Laws and Regulations.

**STANDARD GENERAL CONDITIONS
OF THE CONSTRUCTION CONTRACT**

Prepared by



Issued and Published Jointly by



These General Conditions have been prepared for use with the Agreement Between Owner and Contractor for Construction Contract (EJCDC® C-520, Stipulated Sum, or C-525, Cost-Plus, 2013 Editions). Their provisions are interrelated and a change in one may necessitate a change in the other.

To prepare supplementary conditions that are coordinated with the General Conditions, use EJCDC's Guide to the Preparation of Supplementary Conditions (EJCDC® C-800, 2013 Edition). The full EJCDC Construction series of

documents is discussed in the Commentary on the 2013 EJCDC Construction Documents (EJCDC® C-001, 2013 Edition).

Copyright © 2013:

National Society of Professional Engineers
1420 King Street, Alexandria, VA 22314-2794
(703) 684-2882
www.nspe.org

American Council of Engineering Companies
1015 15th Street N.W., Washington, DC 20005
(202) 347-7474
www.acec.org

American Society of Civil Engineers
1801 Alexander Bell Drive, Reston, VA 20191-4400
(800) 548-2723
www.asce.org

The copyright for this document is owned jointly by the three sponsoring organizations listed above. The National Society of Professional Engineers is the Copyright Administrator for the EJCDC documents; please direct all inquiries regarding EJCDC copyrights to NSPE.

NOTE: EJCDC publications may be purchased at www.ejcdc.org, or from any of the sponsoring organizations above.

TABLE OF CONTENTS

	Page
<u>Article 1 – Definitions and Terminology</u>	7
<u>1.01 Defined Terms</u>	7
<u>1.02 Terminology</u>	10
<u>Article 2 – Preliminary Matters</u>	11
<u>2.01 Delivery of Bonds and Evidence of Insurance</u>	11
<u>2.02 Copies of Documents</u>	11
<u>2.03 Before Starting Construction</u>	11
<u>2.04 Preconstruction Conference; Designation of Authorized Representatives</u>	12
<u>2.05 Initial Acceptance of Schedules</u>	12
<u>2.06 Electronic Transmittals</u>	12
<u>Article 3 – Documents: Intent, Requirements, Reuse</u>	13
<u>3.01 Intent</u>	13
<u>3.02 Reference Standards</u>	13
<u>3.03 Reporting and Resolving Discrepancies</u>	13
<u>3.04 Requirements of the Contract Documents</u>	14
<u>3.05 Reuse of Documents</u>	14
<u>Article 4 – Commencement and Progress of the Work</u>	15
<u>4.01 Commencement of Contract Times; Notice to Proceed</u>	15
<u>4.02 Starting the Work</u>	15
<u>4.03 Reference Points</u>	15
<u>4.04 Progress Schedule</u>	15
<u>4.05 Delays in Contractor’s Progress</u>	15
<u>Article 5 – Availability of Lands; Subsurface and Physical Conditions; Hazardous Environmental Conditions</u>	16
<u>5.01 Availability of Lands</u>	16
<u>5.02 Use of Site and Other Areas</u>	16
<u>5.03 Subsurface and Physical Conditions</u>	17
<u>5.04 Differing Subsurface or Physical Conditions</u>	18
<u>5.05 Underground Facilities</u>	19
<u>5.06 Hazardous Environmental Conditions at Site</u>	20
<u>Article 6 – Bonds and Insurance</u>	22
<u>6.01 Performance, Payment, and Other Bonds</u>	22
<u>6.02 Insurance—General Provisions</u>	23

EJCDC® -, Standard General Conditions of the Construction Contract.
 Copyright © 2013 National Society of Professional Engineers, American Council of Engineering Companies,
 and American Society of Civil Engineers. All rights reserved.

<u>6.03</u>	<u>Contractor’s Insurance</u>	24
<u>6.04</u>	<u>Owner’s Liability Insurance</u>	25
<u>6.05</u>	<u>Property Insurance</u>	26
<u>6.06</u>	<u>Waiver of Rights</u>	27
<u>6.07</u>	<u>Receipt and Application of Property Insurance Proceeds</u>	28
<u>Article 7 – Contractor’s Responsibilities</u>		28
<u>7.01</u>	<u>Supervision and Superintendence</u>	28
<u>7.02</u>	<u>Labor; Working Hours</u>	29
<u>7.03</u>	<u>Services, Materials, and Equipment</u>	29
<u>7.04</u>	<u>“Or Equals”</u>	29
<u>7.05</u>	<u>Substitutes</u>	30
<u>7.06</u>	<u>Concerning Subcontractors, Suppliers, and Others</u>	31
<u>7.07</u>	<u>Patent Fees and Royalties</u>	32
<u>7.08</u>	<u>Permits</u>	33
<u>7.09</u>	<u>Taxes</u>	33
<u>7.10</u>	<u>Laws and Regulations</u>	33
<u>7.11</u>	<u>Record Documents</u>	34
<u>7.12</u>	<u>Safety and Protection</u>	34
<u>7.13</u>	<u>Safety Representative</u>	35
<u>7.14</u>	<u>Hazard Communication Programs</u>	35
<u>7.15</u>	<u>Emergencies</u>	35
<u>7.16</u>	<u>Shop Drawings, Samples, and Other Submittals</u>	35
<u>7.17</u>	<u>Contractor’s General Warranty and Guarantee</u>	37
<u>7.18</u>	<u>Indemnification</u>	37
<u>7.19</u>	<u>Delegation of Professional Design Services</u>	38
<u>Article 8 – Other Work at the Site</u>		39
<u>8.01</u>	<u>Other Work</u>	39
<u>8.02</u>	<u>Coordination</u>	39
<u>8.03</u>	<u>Legal Relationships</u>	39
<u>Article 9 – Owner’s Responsibilities</u>		40
<u>9.01</u>	<u>Communications to Contractor</u>	40
<u>9.02</u>	<u>Replacement of Engineer</u>	40
<u>9.03</u>	<u>Furnish Data</u>	40
<u>9.04</u>	<u>Pay When Due</u>	40

<u>9.05</u>	<u>Lands and Easements; Reports, Tests, and Drawings</u>	40
<u>9.06</u>	<u>Insurance</u>	41
<u>9.07</u>	<u>Change Orders</u>	41
<u>9.08</u>	<u>Inspections, Tests, and Approvals</u>	41
<u>9.09</u>	<u>Limitations on Owner’s Responsibilities</u>	41
<u>9.10</u>	<u>Undisclosed Hazardous Environmental Condition</u>	41
<u>9.11</u>	<u>Evidence of Financial Arrangements</u>	41
<u>9.12</u>	<u>Safety Programs</u>	41
<u>Article 10 – Engineer’s Status During Construction</u>		41
<u>10.01</u>	<u>Owner’s Representative</u>	41
<u>10.02</u>	<u>Visits to Site</u>	41
<u>10.03</u>	<u>Project Representative</u>	42
<u>10.04</u>	<u>Rejecting Defective Work</u>	42
<u>10.05</u>	<u>Shop Drawings, Change Orders and Payments</u>	42
<u>10.06</u>	<u>Determinations for Unit Price Work</u>	42
<u>10.07</u>	<u>Decisions on Requirements of Contract Documents and Acceptability of Work</u>	42
<u>10.08</u>	<u>Limitations on Engineer’s Authority and Responsibilities</u>	42
<u>10.09</u>	<u>Compliance with Safety Program</u>	43
<u>Article 11 – Amending the Contract Documents; Changes in the Work</u>		43
<u>11.01</u>	<u>Amending and Supplementing Contract Documents</u>	43
<u>11.02</u>	<u>Owner-Authorized Changes in the Work</u>	44
<u>11.03</u>	<u>Unauthorized Changes in the Work</u>	44
<u>11.04</u>	<u>Change of Contract Price</u>	44
<u>11.05</u>	<u>Change of Contract Times</u>	45
<u>11.06</u>	<u>Change Proposals</u>	45
<u>11.07</u>	<u>Execution of Change Orders</u>	46
<u>11.08</u>	<u>Notification to Surety</u>	46
<u>Article 12 – Claims</u>		46
<u>12.01</u>	<u>Claims</u>	46
<u>Article 13 – Cost of the Work; Allowances; Unit Price Work</u>		47
<u>13.01</u>	<u>Cost of the Work</u>	47
<u>13.02</u>	<u>Allowances</u>	49
<u>13.03</u>	<u>Unit Price Work</u>	50
<u>Article 14 – Tests and Inspections; Correction, Removal or Acceptance of Defective Work</u>		50
<u>14.01</u>	<u>Access to Work</u>	50

EJCDC® -, Standard General Conditions of the Construction Contract.
 Copyright © 2013 National Society of Professional Engineers, American Council of Engineering Companies,
 and American Society of Civil Engineers. All rights reserved.

<u>14.02</u>	<u>Tests, Inspections, and Approvals</u>	50
<u>14.03</u>	<u>Defective Work</u>	51
<u>14.04</u>	<u>Acceptance of Defective Work</u>	52
<u>14.05</u>	<u>Uncovering Work</u>	52
<u>14.06</u>	<u>Owner May Stop the Work</u>	52
<u>14.07</u>	<u>Owner May Correct Defective Work</u>	53
<u>Article 15 – Payments to Contractor; Set-Offs; Completion; Correction Period</u>		53
<u>15.01</u>	<u>Progress Payments</u>	53
<u>15.02</u>	<u>Contractor’s Warranty of Title</u>	56
<u>15.03</u>	<u>Substantial Completion</u>	56
<u>15.04</u>	<u>Partial Use or Occupancy</u>	57
<u>15.05</u>	<u>Final Inspection</u>	57
<u>15.06</u>	<u>Final Payment</u>	57
<u>15.07</u>	<u>Waiver of Claims</u>	58
<u>15.08</u>	<u>Correction Period</u>	58
<u>Article 16 – Suspension of Work and Termination</u>		59
<u>16.01</u>	<u>Owner May Suspend Work</u>	59
<u>16.02</u>	<u>Owner May Terminate for Cause</u>	59
<u>16.03</u>	<u>Owner May Terminate For Convenience</u>	60
<u>16.04</u>	<u>Contractor May Stop Work or Terminate</u>	60
<u>Article 17 – Final Resolution of Disputes</u>		61
<u>17.01</u>	<u>Methods and Procedures</u>	61
<u>Article 18 – Miscellaneous</u>		61
<u>18.01</u>	<u>Giving Notice</u>	61
<u>18.02</u>	<u>Computation of Times</u>	61
<u>18.03</u>	<u>Cumulative Remedies</u>	61
<u>18.04</u>	<u>Limitation of Damages</u>	62
<u>18.05</u>	<u>No Waiver</u>	62
<u>18.06</u>	<u>Survival of Obligations</u>	62
<u>18.07</u>	<u>Controlling Law</u>	62
<u>18.08</u>	<u>Headings</u>	62

ARTICLE 1 – DEFINITIONS AND TERMINOLOGY

1.01 Defined Terms

- A. Wherever used in the Bidding Requirements or Contract Documents, a term printed with initial capital letters, including the term's singular and plural forms, will have the meaning indicated in the definitions below. In addition to terms specifically defined, terms with initial capital letters in the Contract Documents include references to identified articles and paragraphs, and the titles of other documents or forms.
1. *Addenda*—Written or graphic instruments issued prior to the opening of Bids which clarify, correct, or change the Bidding Requirements or the proposed Contract Documents.
 2. *Agreement*—The written instrument, executed by Owner and Contractor, that sets forth the Contract Price and Contract Times, identifies the parties and the Engineer, and designates the specific items that are Contract Documents.
 3. *Application for Payment*—The form acceptable to Engineer which is to be used by Contractor during the course of the Work in requesting progress or final payments and which is to be accompanied by such supporting documentation as is required by the Contract Documents.
 4. *Bid*—The offer of a Bidder submitted on the prescribed form setting forth the prices for the Work to be performed.
 5. *Bidder*—An individual or entity that submits a Bid to Owner.
 6. *Bidding Documents*—The Bidding Requirements, the proposed Contract Documents, and all Addenda.
 7. *Bidding Requirements*—The advertisement or invitation to bid, Instructions to Bidders, Bid Bond or other Bid security, if any, the Bid Form, and the Bid with any attachments.
 8. *Change Order*—A document which is signed by Contractor and Owner and authorizes an addition, deletion, or revision in the Work or an adjustment in the Contract Price or the Contract Times, or other revision to the Contract, issued on or after the Effective Date of the Contract.
 9. *Change Proposal*—A written request by Contractor, duly submitted in compliance with the procedural requirements set forth herein, seeking an adjustment in Contract Price or Contract Times, or both; contesting an initial decision by Engineer concerning the requirements of the Contract Documents or the acceptability of Work under the Contract Documents; challenging a set-off against payments due; or seeking other relief with respect to the terms of the Contract.
 10. *Claim*—(a) A demand or assertion by Owner directly to Contractor, duly submitted in compliance with the procedural requirements set forth herein: seeking an adjustment of Contract Price or Contract Times, or both; contesting an initial decision by Engineer concerning the requirements of the Contract Documents or the acceptability of Work under the Contract Documents; contesting Engineer's decision regarding a Change Proposal; seeking resolution of a contractual issue that Engineer has declined to address; or seeking other relief with respect to the terms of the Contract; or (b) a demand or assertion by Contractor directly to Owner, duly submitted in compliance with the procedural requirements set forth herein, contesting Engineer's decision regarding a Change Proposal; or seeking resolution of a contractual issue that Engineer has declined to address. A demand for money or services by a third party is not a Claim.
 11. *Constituent of Concern*—Asbestos, petroleum, radioactive materials, polychlorinated biphenyls (PCBs), hazardous waste, and any substance, product, waste, or other material of any nature whatsoever that is or becomes listed, regulated, or addressed pursuant to (a) the Comprehensive Environmental Response, Compensation and Liability Act, 42 U.S.C. §§9601 et seq. ("CERCLA"); (b) the Hazardous Materials Transportation Act, 49 U.S.C. §§5101 et seq.; (c)

EJCDC® - Standard General Conditions of the Construction Contract.

Copyright © 2013 National Society of Professional Engineers, American Council of Engineering Companies, and American Society of Civil Engineers. All rights reserved.

- the Resource Conservation and Recovery Act, 42 U.S.C. §§6901 et seq. ("RCRA"); (d) the Toxic Substances Control Act, 15 U.S.C. §§2601 et seq.; (e) the Clean Water Act, 33 U.S.C. §§1251 et seq.; (f) the Clean Air Act, 42 U.S.C. §§7401 et seq.; or (g) any other federal, state, or local statute, law, rule, regulation, ordinance, resolution, code, order, or decree regulating, relating to, or imposing liability or standards of conduct concerning, any hazardous, toxic, or dangerous waste, substance, or material.
12. *Contract*—The entire and integrated written contract between the Owner and Contractor concerning the Work.
 13. *Contract Documents*—Those items so designated in the Agreement, and which together comprise the Contract.
 14. *Contract Price*—The money that Owner has agreed to pay Contractor for completion of the Work in accordance with the Contract Documents. .
 15. *Contract Times*—The number of days or the dates by which Contractor shall: (a) achieve Milestones, if any; (b) achieve Substantial Completion; and (c) complete the Work.
 16. *Contractor*—The individual or entity with which Owner has contracted for performance of the Work.
 17. *Cost of the Work*—See Paragraph 13.01 for definition.
 18. *Drawings*—The part of the Contract that graphically shows the scope, extent, and character of the Work to be performed by Contractor.
 19. *Effective Date of the Contract*—The date, indicated in the Agreement, on which the Contract becomes effective.
 20. *Engineer*—The individual or entity named as such in the Agreement.
 21. *Field Order*—A written order issued by Engineer which requires minor changes in the Work but does not change the Contract Price or the Contract Times.
 22. *Hazardous Environmental Condition*—The presence at the Site of Constituents of Concern in such quantities or circumstances that may present a danger to persons or property exposed thereto. The presence at the Site of materials that are necessary for the execution of the Work, or that are to be incorporated in the Work, and that are controlled and contained pursuant to industry practices, Laws and Regulations, and the requirements of the Contract, does not establish a Hazardous Environmental Condition.
 23. *Laws and Regulations; Laws or Regulations*—Any and all applicable laws, statutes, rules, regulations, ordinances, codes, and orders of any and all governmental bodies, agencies, authorities, and courts having jurisdiction.
 24. *Liens*—Charges, security interests, or encumbrances upon Contract-related funds, real property, or personal property.
 25. *Milestone*—A principal event in the performance of the Work that the Contract requires Contractor to achieve by an intermediate completion date or by a time prior to Substantial Completion of all the Work.
 26. *Notice of Award*—The written notice by Owner to a Bidder of Owner's acceptance of the Bid.
 27. *Notice to Proceed*—A written notice by Owner to Contractor fixing the date on which the Contract Times will commence to run and on which Contractor shall start to perform the Work.
 28. *Owner*—The individual or entity with which Contractor has contracted regarding the Work, and which has agreed to pay Contractor for the performance of the Work, pursuant to the terms of the Contract.
 29. *Progress Schedule*—A schedule, prepared and maintained by Contractor, describing the sequence and duration of the activities comprising the Contractor's plan to accomplish the Work within the Contract Times.

30. *Project*—The total undertaking to be accomplished for Owner by engineers, contractors, and others, including planning, study, design, construction, testing, commissioning, and start-up, and of which the Work to be performed under the Contract Documents is a part.
31. *Project Manual*—The written documents prepared for, or made available for, procuring and constructing the Work, including but not limited to the Bidding Documents or other construction procurement documents, geotechnical and existing conditions information, the Agreement, bond forms, General Conditions, Supplementary Conditions, and Specifications. The contents of the Project Manual may be bound in one or more volumes.
32. *Resident Project Representative*—The authorized representative of Engineer assigned to assist Engineer at the Site. As used herein, the term Resident Project Representative or “RPR” includes any assistants or field staff of Resident Project Representative.
33. *Samples*—Physical examples of materials, equipment, or workmanship that are representative of some portion of the Work and that establish the standards by which such portion of the Work will be judged.
34. *Schedule of Submittals*—A schedule, prepared and maintained by Contractor, of required submittals and the time requirements for Engineer’s review of the submittals and the performance of related construction activities.
35. *Schedule of Values*—A schedule, prepared and maintained by Contractor, allocating portions of the Contract Price to various portions of the Work and used as the basis for reviewing Contractor’s Applications for Payment.
36. *Shop Drawings*—All drawings, diagrams, illustrations, schedules, and other data or information that are specifically prepared or assembled by or for Contractor and submitted by Contractor to illustrate some portion of the Work. Shop Drawings, whether approved or not, are not Drawings and are not Contract Documents.
37. *Site*—Lands or areas indicated in the Contract Documents as being furnished by Owner upon which the Work is to be performed, including rights-of-way and easements, and such other lands furnished by Owner which are designated for the use of Contractor.
38. *Specifications*—The part of the Contract that consists of written requirements for materials, equipment, systems, standards, and workmanship as applied to the Work, and certain administrative requirements and procedural matters applicable to the Work.
39. *Subcontractor*—An individual or entity having a direct contract with Contractor or with any other Subcontractor for the performance of a part of the Work.
40. *Substantial Completion*—The time at which the Work (or a specified part thereof) has progressed to the point where, in the opinion of Engineer, the Work (or a specified part thereof) is sufficiently complete, in accordance with the Contract Documents, so that the Work (or a specified part thereof) can be utilized for the purposes for which it is intended. The terms “substantially complete” and “substantially completed” as applied to all or part of the Work refer to Substantial Completion thereof.
41. *Successful Bidder*—The Bidder whose Bid the Owner accepts, and to which the Owner makes an award of contract, subject to stated conditions.
42. *Supplementary Conditions*—The part of the Contract that amends or supplements these General Conditions.
43. *Supplier*—A manufacturer, fabricator, supplier, distributor, materialman, or vendor having a direct contract with Contractor or with any Subcontractor to furnish materials or equipment to be incorporated in the Work by Contractor or a Subcontractor.
44. *Technical Data*—Those items expressly identified as Technical Data in the Supplementary Conditions, with respect to either (a) subsurface conditions at the Site, or physical conditions relating to existing surface or subsurface structures at the Site (except Underground Facilities)

EJCDC® - Standard General Conditions of the Construction Contract.

Copyright © 2013 National Society of Professional Engineers, American Council of Engineering Companies, and American Society of Civil Engineers. All rights reserved.

or (b) Hazardous Environmental Conditions at the Site. If no such express identifications of Technical Data have been made with respect to conditions at the Site, then the data contained in boring logs, recorded measurements of subsurface water levels, laboratory test results, and other factual, objective information regarding conditions at the Site that are set forth in any geotechnical or environmental report prepared for the Project and made available to Contractor are hereby defined as Technical Data with respect to conditions at the Site under Paragraphs 5.03, 5.04, and 5.06.

45. *Underground Facilities*—All underground pipelines, conduits, ducts, cables, wires, manholes, vaults, tanks, tunnels, or other such facilities or attachments, and any encasements containing such facilities, including but not limited to those that convey electricity, gases, steam, liquid petroleum products, telephone or other communications, fiber optic transmissions, cable television, water, wastewater, storm water, other liquids or chemicals, or traffic or other control systems.
46. *Unit Price Work*—Work to be paid for on the basis of unit prices.
47. *Work*—The entire construction or the various separately identifiable parts thereof required to be provided under the Contract Documents. Work includes and is the result of performing or providing all labor, services, and documentation necessary to produce such construction; furnishing, installing, and incorporating all materials and equipment into such construction; and may include related services such as testing, start-up, and commissioning, all as required by the Contract Documents.
48. *Work Change Directive*—A written directive to Contractor issued on or after the Effective Date of the Contract, signed by Owner and recommended by Engineer, ordering an addition, deletion, or revision in the Work.

1.02 Terminology

- A. The words and terms discussed in the following paragraphs are not defined but, when used in the Bidding Requirements or Contract Documents, have the indicated meaning.
- B. *Intent of Certain Terms or Adjectives*:
 1. The Contract Documents include the terms “as allowed,” “as approved,” “as ordered,” “as directed” or terms of like effect or import to authorize an exercise of professional judgment by Engineer. In addition, the adjectives “reasonable,” “suitable,” “acceptable,” “proper,” “satisfactory,” or adjectives of like effect or import are used to describe an action or determination of Engineer as to the Work. It is intended that such exercise of professional judgment, action, or determination will be solely to evaluate, in general, the Work for compliance with the information in the Contract Documents and with the design concept of the Project as a functioning whole as shown or indicated in the Contract Documents (unless there is a specific statement indicating otherwise). The use of any such term or adjective is not intended to and shall not be effective to assign to Engineer any duty or authority to supervise or direct the performance of the Work, or any duty or authority to undertake responsibility contrary to the provisions of Article 10 or any other provision of the Contract Documents.
- C. *Day*:
 1. The word “day” means a calendar day of 24 hours measured from midnight to the next midnight.
- D. *Defective*:
 1. The word “defective,” when modifying the word “Work,” refers to Work that is unsatisfactory, faulty, or deficient in that it:
 - a. does not conform to the Contract Documents; or
 - b. does not meet the requirements of any applicable inspection, reference standard, test, or approval referred to in the Contract Documents; or

EJCDC® -, Standard General Conditions of the Construction Contract.

Copyright © 2013 National Society of Professional Engineers, American Council of Engineering Companies, and American Society of Civil Engineers. All rights reserved.

- c. has been damaged prior to Engineer's recommendation of final payment (unless responsibility for the protection thereof has been assumed by Owner at Substantial Completion in accordance with Paragraph 15.03 or 15.04).
- E. *Furnish, Install, Perform, Provide:*
1. The word "furnish," when used in connection with services, materials, or equipment, shall mean to supply and deliver said services, materials, or equipment to the Site (or some other specified location) ready for use or installation and in usable or operable condition.
 2. The word "install," when used in connection with services, materials, or equipment, shall mean to put into use or place in final position said services, materials, or equipment complete and ready for intended use.
 3. The words "perform" or "provide," when used in connection with services, materials, or equipment, shall mean to furnish and install said services, materials, or equipment complete and ready for intended use.
 4. If the Contract Documents establish an obligation of Contractor with respect to specific services, materials, or equipment, but do not expressly use any of the four words "furnish," "install," "perform," or "provide," then Contractor shall furnish and install said services, materials, or equipment complete and ready for intended use.
- F. Unless stated otherwise in the Contract Documents, words or phrases that have a well-known technical or construction industry or trade meaning are used in the Contract Documents in accordance with such recognized meaning.

ARTICLE 2 – PRELIMINARY MATTERS

2.01 Delivery of Bonds and Evidence of Insurance

- A. *Bonds:* When Contractor delivers the executed counterparts of the Agreement to Owner, Contractor shall also deliver to Owner such bonds as Contractor may be required to furnish.
- B. *Evidence of Contractor's Insurance:* When Contractor delivers the executed counterparts of the Agreement to Owner, Contractor shall also deliver to Owner, with copies to each named insured and additional insured (as identified in the Supplementary Conditions or elsewhere in the Contract), the certificates and other evidence of insurance required to be provided by Contractor in accordance with Article 6.
- C. *Evidence of Owner's Insurance:* After receipt of the executed counterparts of the Agreement and all required bonds and insurance documentation, Owner shall promptly deliver to Contractor, with copies to each named insured and additional insured (as identified in the Supplementary Conditions or otherwise), the certificates and other evidence of insurance required to be provided by Owner under Article 6.

2.02 Copies of Documents

- A. Owner shall furnish to Contractor four printed copies of the Contract (including one fully executed counterpart of the Agreement), and one copy in electronic portable document format (PDF). Additional printed copies will be furnished upon request at the cost of reproduction.
- B. Owner shall maintain and safeguard at least one original printed record version of the Contract, including Drawings and Specifications signed and sealed by Engineer and other design professionals. Owner shall make such original printed record version of the Contract available to Contractor for review. Owner may delegate the responsibilities under this provision to Engineer.

2.03 Before Starting Construction

- A. *Preliminary Schedules:* Within 10 days after the Effective Date of the Contract (or as otherwise specifically required by the Contract Documents), Contractor shall submit to Engineer for timely review:

EJCDC® - Standard General Conditions of the Construction Contract.

Copyright © 2013 National Society of Professional Engineers, American Council of Engineering Companies, and American Society of Civil Engineers. All rights reserved.

1. a preliminary Progress Schedule indicating the times (numbers of days or dates) for starting and completing the various stages of the Work, including any Milestones specified in the Contract;
 2. a preliminary Schedule of Submittals; and
 3. a preliminary Schedule of Values for all of the Work which includes quantities and prices of items which when added together equal the Contract Price and subdivides the Work into component parts in sufficient detail to serve as the basis for progress payments during performance of the Work. Such prices will include an appropriate amount of overhead and profit applicable to each item of Work.
- 2.04 Preconstruction Conference; Designation of Authorized Representatives
- A. Before any Work at the Site is started, a conference attended by Owner, Contractor, Engineer, and others as appropriate will be held to establish a working understanding among the parties as to the Work and to discuss the schedules referred to in Paragraph 2.03.A, procedures for handling Shop Drawings, Samples, and other submittals, processing Applications for Payment, electronic or digital transmittals, and maintaining required records.
 - B. At this conference Owner and Contractor each shall designate, in writing, a specific individual to act as its authorized representative with respect to the services and responsibilities under the Contract. Such individuals shall have the authority to transmit and receive information, render decisions relative to the Contract, and otherwise act on behalf of each respective party.
- 2.05 Initial Acceptance of Schedules
- A. At least 10 days before submission of the first Application for Payment a conference, attended by Contractor, Engineer, and others as appropriate, will be held to review for acceptability to Engineer as provided below the schedules submitted in accordance with Paragraph 2.03.A. Contractor shall have an additional 10 days to make corrections and adjustments and to complete and resubmit the schedules. No progress payment shall be made to Contractor until acceptable schedules are submitted to Engineer.
 1. The Progress Schedule will be acceptable to Engineer if it provides an orderly progression of the Work to completion within the Contract Times. Such acceptance will not impose on Engineer responsibility for the Progress Schedule, for sequencing, scheduling, or progress of the Work, nor interfere with or relieve Contractor from Contractor's full responsibility therefor.
 2. Contractor's Schedule of Submittals will be acceptable to Engineer if it provides a workable arrangement for reviewing and processing the required submittals.
 3. Contractor's Schedule of Values will be acceptable to Engineer as to form and substance if it provides a reasonable allocation of the Contract Price to the component parts of the Work.
- 2.06 Electronic Transmittals
- A. Except as otherwise stated elsewhere in the Contract, the Owner, Engineer, and Contractor may transmit, and shall accept, Project-related correspondence, text, data, documents, drawings, information, and graphics, including but not limited to Shop Drawings and other submittals, in electronic media or digital format, either directly, or through access to a secure Project website.
 - B. If the Contract does not establish protocols for electronic or digital transmittals, then Owner, Engineer, and Contractor shall jointly develop such protocols.
 - C. When transmitting items in electronic media or digital format, the transmitting party makes no representations as to long term compatibility, usability, or readability of the items resulting from the recipient's use of software application packages, operating systems, or computer hardware differing from those used in the drafting or transmittal of the items, or from those established in applicable transmittal protocols.

ARTICLE 3 – DOCUMENTS: INTENT, REQUIREMENTS, REUSE

3.01 Intent

- A. The Contract Documents are complementary; what is required by one is as binding as if required by all.
- B. It is the intent of the Contract Documents to describe a functionally complete project (or part thereof) to be constructed in accordance with the Contract Documents.
- C. Unless otherwise stated in the Contract Documents, if there is a discrepancy between the electronic or digital versions of the Contract Documents (including any printed copies derived from such electronic or digital versions) and the printed record version, the printed record version shall govern.
- D. The Contract supersedes prior negotiations, representations, and agreements, whether written or oral.
- E. Engineer will issue clarifications and interpretations of the Contract Documents as provided herein.

3.02 Reference Standards

- A. Standards Specifications, Codes, Laws and Regulations
 1. Reference in the Contract Documents to standard specifications, manuals, reference standards, or codes of any technical society, organization, or association, or to Laws or Regulations, whether such reference be specific or by implication, shall mean the standard specification, manual, reference standard, code, or Laws or Regulations in effect at the time of opening of Bids (or on the Effective Date of the Contract if there were no Bids), except as may be otherwise specifically stated in the Contract Documents.
 2. No provision of any such standard specification, manual, reference standard, or code, or any instruction of a Supplier, shall be effective to change the duties or responsibilities of Owner, Contractor, or Engineer, or any of their subcontractors, consultants, agents, or employees, from those set forth in the part of the Contract Documents prepared by or for Engineer. No such provision or instruction shall be effective to assign to Owner, Engineer, or any of their officers, directors, members, partners, employees, agents, consultants, or subcontractors, any duty or authority to supervise or direct the performance of the Work or any duty or authority to undertake responsibility inconsistent with the provisions of the part of the Contract Documents prepared by or for Engineer.

3.03 Reporting and Resolving Discrepancies

A. *Reporting Discrepancies:*

1. *Contractor's Verification of Figures and Field Measurements:* Before undertaking each part of the Work, Contractor shall carefully study the Contract Documents, and check and verify pertinent figures and dimensions therein, particularly with respect to applicable field measurements. Contractor shall promptly report in writing to Engineer any conflict, error, ambiguity, or discrepancy that Contractor discovers, or has actual knowledge of, and shall not proceed with any Work affected thereby until the conflict, error, ambiguity, or discrepancy is resolved, by a clarification or interpretation by Engineer, or by an amendment or supplement to the Contract Documents issued pursuant to Paragraph 11.01.
2. *Contractor's Review of Contract Documents:* If, before or during the performance of the Work, Contractor discovers any conflict, error, ambiguity, or discrepancy within the Contract Documents, or between the Contract Documents and (a) any applicable Law or Regulation, (b) actual field conditions, (c) any standard specification, manual, reference standard, or code, or (d) any instruction of any Supplier, then Contractor shall promptly report it to Engineer in writing. Contractor shall not proceed with the Work affected thereby (except in an emergency as required by Paragraph 7.15) until the conflict, error, ambiguity, or discrepancy is resolved,

EJCDC® -, Standard General Conditions of the Construction Contract.

Copyright © 2013 National Society of Professional Engineers, American Council of Engineering Companies, and American Society of Civil Engineers. All rights reserved.

by a clarification or interpretation by Engineer, or by an amendment or supplement to the Contract Documents issued pursuant to Paragraph 11.01.

3. Contractor shall not be liable to Owner or Engineer for failure to report any conflict, error, ambiguity, or discrepancy in the Contract Documents unless Contractor had actual knowledge thereof.

B. *Resolving Discrepancies:*

1. Except as may be otherwise specifically stated in the Contract Documents, the provisions of the part of the Contract Documents prepared by or for Engineer shall take precedence in resolving any conflict, error, ambiguity, or discrepancy between such provisions of the Contract Documents and:
 - a. the provisions of any standard specification, manual, reference standard, or code, or the instruction of any Supplier (whether or not specifically incorporated by reference as a Contract Document); or
 - b. the provisions of any Laws or Regulations applicable to the performance of the Work (unless such an interpretation of the provisions of the Contract Documents would result in violation of such Law or Regulation).

3.04 Requirements of the Contract Documents

- A. During the performance of the Work and until final payment, Contractor and Owner shall submit to the Engineer all matters in question concerning the requirements of the Contract Documents (sometimes referred to as requests for information or interpretation—RFIs), or relating to the acceptability of the Work under the Contract Documents, as soon as possible after such matters arise. Engineer will be the initial interpreter of the requirements of the Contract Documents, and judge of the acceptability of the Work thereunder.
- B. Engineer will, with reasonable promptness, render a written clarification, interpretation, or decision on the issue submitted, or initiate an amendment or supplement to the Contract Documents. Engineer's written clarification, interpretation, or decision will be final and binding on Contractor, unless it appeals by submitting a Change Proposal, and on Owner, unless it appeals by filing a Claim.
- C. If a submitted matter in question concerns terms and conditions of the Contract Documents that do not involve (1) the performance or acceptability of the Work under the Contract Documents, (2) the design (as set forth in the Drawings, Specifications, or otherwise), or (3) other engineering or technical matters, then Engineer will promptly give written notice to Owner and Contractor that Engineer is unable to provide a decision or interpretation. If Owner and Contractor are unable to agree on resolution of such a matter in question, either party may pursue resolution as provided in Article 12.

3.05 Reuse of Documents

- A. Contractor and its Subcontractors and Suppliers shall not:
 1. have or acquire any title to or ownership rights in any of the Drawings, Specifications, or other documents (or copies of any thereof) prepared by or bearing the seal of Engineer or its consultants, including electronic media editions, or reuse any such Drawings, Specifications, other documents, or copies thereof on extensions of the Project or any other project without written consent of Owner and Engineer and specific written verification or adaptation by Engineer; or
 2. have or acquire any title or ownership rights in any other Contract Documents, reuse any such Contract Documents for any purpose without Owner's express written consent, or violate any copyrights pertaining to such Contract Documents.
- B. The prohibitions of this Paragraph 3.05 will survive final payment, or termination of the Contract. Nothing herein shall preclude Contractor from retaining copies of the Contract Documents for record purposes.

EJCDC® - Standard General Conditions of the Construction Contract.

Copyright © 2013 National Society of Professional Engineers, American Council of Engineering Companies, and American Society of Civil Engineers. All rights reserved.

ARTICLE 4 – COMMENCEMENT AND PROGRESS OF THE WORK**4.01 Commencement of Contract Times; Notice to Proceed**

- A. The Contract Times will commence to run on the thirtieth day after the Effective Date of the Contract or, if a Notice to Proceed is given, on the day indicated in the Notice to Proceed. A Notice to Proceed may be given at any time within 30 days after the Effective Date of the Contract. In no event will the Contract Times commence to run later than the sixtieth day after the day of Bid opening or the thirtieth day after the Effective Date of the Contract, whichever date is earlier.

4.02 Starting the Work

- A. Contractor shall start to perform the Work on the date when the Contract Times commence to run. No Work shall be done at the Site prior to such date.

4.03 Reference Points

- A. Owner shall provide engineering surveys to establish reference points for construction which in Engineer's judgment are necessary to enable Contractor to proceed with the Work. Contractor shall be responsible for laying out the Work, shall protect and preserve the established reference points and property monuments, and shall make no changes or relocations without the prior written approval of Owner. Contractor shall report to Engineer whenever any reference point or property monument is lost or destroyed or requires relocation because of necessary changes in grades or locations, and shall be responsible for the accurate replacement or relocation of such reference points or property monuments by professionally qualified personnel.

4.04 Progress Schedule

- A. Contractor shall adhere to the Progress Schedule established in accordance with Paragraph 2.05 as it may be adjusted from time to time as provided below.
1. Contractor shall submit to Engineer for acceptance (to the extent indicated in Paragraph 2.05) proposed adjustments in the Progress Schedule that will not result in changing the Contract Times.
 2. Proposed adjustments in the Progress Schedule that will change the Contract Times shall be submitted in accordance with the requirements of Article 11.
- B. Contractor shall carry on the Work and adhere to the Progress Schedule during all disputes or disagreements with Owner. No Work shall be delayed or postponed pending resolution of any disputes or disagreements, or during any appeal process, except as permitted by Paragraph 16.04, or as Owner and Contractor may otherwise agree in writing.

4.05 Delays in Contractor's Progress

- A. If Owner, Engineer, or anyone for whom Owner is responsible, delays, disrupts, or interferes with the performance or progress of the Work, then Contractor shall be entitled to an equitable adjustment in the Contract Times and Contract Price. Contractor's entitlement to an adjustment of the Contract Times is conditioned on such adjustment being essential to Contractor's ability to complete the Work within the Contract Times.
- B. Contractor shall not be entitled to an adjustment in Contract Price or Contract Times for delay, disruption, or interference caused by or within the control of Contractor. Delay, disruption, and interference attributable to and within the control of a Subcontractor or Supplier shall be deemed to be within the control of Contractor.
- C. If Contractor's performance or progress is delayed, disrupted, or interfered with by unanticipated causes not the fault of and beyond the control of Owner, Contractor, and those for which they are responsible, then Contractor shall be entitled to an equitable adjustment in Contract Times. Contractor's entitlement to an adjustment of the Contract Times is conditioned on such adjustment being essential to Contractor's ability to complete the Work within the Contract Times. Such an adjustment shall be Contractor's sole and exclusive remedy for the delays, disruption, and

interference described in this paragraph. Causes of delay, disruption, or interference that may give rise to an adjustment in Contract Times under this paragraph include but are not limited to the following:

1. severe and unavoidable natural catastrophes such as fires, floods, epidemics, and earthquakes;
 2. abnormal weather conditions;
 3. acts or failures to act of utility owners (other than those performing other work at or adjacent to the Site by arrangement with the Owner, as contemplated in Article 8); and
 4. acts of war or terrorism.
- D. Delays, disruption, and interference to the performance or progress of the Work resulting from the existence of a differing subsurface or physical condition, an Underground Facility that was not shown or indicated by the Contract Documents, or not shown or indicated with reasonable accuracy, and those resulting from Hazardous Environmental Conditions, are governed by Article 5.
- E. Paragraph 8.03 governs delays, disruption, and interference to the performance or progress of the Work resulting from the performance of certain other work at or adjacent to the Site.
- F. Contractor shall not be entitled to an adjustment in Contract Price or Contract Times for any delay, disruption, or interference if such delay is concurrent with a delay, disruption, or interference caused by or within the control of Contractor.
- G. Contractor must submit any Change Proposal seeking an adjustment in Contract Price or Contract Times under this paragraph within 30 days of the commencement of the delaying, disrupting, or interfering event.

ARTICLE 5 – AVAILABILITY OF LANDS; SUBSURFACE AND PHYSICAL CONDITIONS; HAZARDOUS ENVIRONMENTAL CONDITIONS

5.01 Availability of Lands

- A. Owner shall furnish the Site. Owner shall notify Contractor of any encumbrances or restrictions not of general application but specifically related to use of the Site with which Contractor must comply in performing the Work.
- B. Upon reasonable written request, Owner shall furnish Contractor with a current statement of record legal title and legal description of the lands upon which permanent improvements are to be made and Owner's interest therein as necessary for giving notice of or filing a mechanic's or construction lien against such lands in accordance with applicable Laws and Regulations.
- C. Contractor shall provide for all additional lands and access thereto that may be required for temporary construction facilities or storage of materials and equipment.

5.02 Use of Site and Other Areas

- A. *Limitation on Use of Site and Other Areas:*
 1. Contractor shall confine construction equipment, temporary construction facilities, the storage of materials and equipment, and the operations of workers to the Site, adjacent areas that Contractor has arranged to use through construction easements or otherwise, and other adjacent areas permitted by Laws and Regulations, and shall not unreasonably encumber the Site and such other adjacent areas with construction equipment or other materials or equipment. Contractor shall assume full responsibility for (a) damage to the Site; (b) damage to any such other adjacent areas used for Contractor's operations; (c) damage to any other adjacent land or areas; and (d) for injuries and losses sustained by the owners or occupants of any such land or areas; provided that such damage or injuries result from the performance of the Work or from other actions or conduct of the Contractor or those for which Contractor is responsible.

2. If a damage or injury claim is made by the owner or occupant of any such land or area because of the performance of the Work, or because of other actions or conduct of the Contractor or those for which Contractor is responsible, Contractor shall (a) take immediate corrective or remedial action as required by Paragraph 7.12, or otherwise; (b) promptly attempt to settle the claim as to all parties through negotiations with such owner or occupant, or otherwise resolve the claim by arbitration or other dispute resolution proceeding, or at law; and (c) to the fullest extent permitted by Laws and Regulations, indemnify and hold harmless Owner and Engineer, and the officers, directors, members, partners, employees, agents, consultants and subcontractors of each and any of them from and against any such claim, and against all costs, losses, and damages (including but not limited to all fees and charges of engineers, architects, attorneys, and other professionals and all court or arbitration or other dispute resolution costs) arising out of or relating to any claim or action, legal or equitable, brought by any such owner or occupant against Owner, Engineer, or any other party indemnified hereunder to the extent caused directly or indirectly, in whole or in part by, or based upon, Contractor's performance of the Work, or because of other actions or conduct of the Contractor or those for which Contractor is responsible.
 - B. *Removal of Debris During Performance of the Work:* During the progress of the Work the Contractor shall keep the Site and other adjacent areas free from accumulations of waste materials, rubbish, and other debris. Removal and disposal of such waste materials, rubbish, and other debris shall conform to applicable Laws and Regulations.
 - C. *Cleaning:* Prior to Substantial Completion of the Work Contractor shall clean the Site and the Work and make it ready for utilization by Owner. At the completion of the Work Contractor shall remove from the Site and adjacent areas all tools, appliances, construction equipment and machinery, and surplus materials and shall restore to original condition all property not designated for alteration by the Contract Documents.
 - D. *Loading of Structures:* Contractor shall not load nor permit any part of any structure to be loaded in any manner that will endanger the structure, nor shall Contractor subject any part of the Work or adjacent structures or land to stresses or pressures that will endanger them.
- 5.03 Subsurface and Physical Conditions
- A. *Reports and Drawings:* The Supplementary Conditions identify:
 1. those reports known to Owner of explorations and tests of subsurface conditions at or adjacent to the Site;
 2. those drawings known to Owner of physical conditions relating to existing surface or subsurface structures at the Site (except Underground Facilities); and
 3. Technical Data contained in such reports and drawings.
 - B. *Reliance by Contractor on Technical Data Authorized:* Contractor may rely upon the accuracy of the Technical Data expressly identified in the Supplementary Conditions with respect to such reports and drawings, but such reports and drawings are not Contract Documents. If no such express identification has been made, then Contractor may rely upon the accuracy of the Technical Data (as defined in Article 1) contained in any geotechnical or environmental report prepared for the Project and made available to Contractor. Except for such reliance on Technical Data, Contractor may not rely upon or make any claim against Owner or Engineer, or any of their officers, directors, members, partners, employees, agents, consultants, or subcontractors, with respect to:
 1. the completeness of such reports and drawings for Contractor's purposes, including, but not limited to, any aspects of the means, methods, techniques, sequences, and procedures of construction to be employed by Contractor, and safety precautions and programs incident thereto; or

2. other data, interpretations, opinions, and information contained in such reports or shown or indicated in such drawings; or
 3. any Contractor interpretation of or conclusion drawn from any Technical Data or any such other data, interpretations, opinions, or information.
- 5.04 Differing Subsurface or Physical Conditions
- A. *Notice by Contractor:* If Contractor believes that any subsurface or physical condition that is uncovered or revealed at the Site either:
1. is of such a nature as to establish that any Technical Data on which Contractor is entitled to rely as provided in Paragraph 5.03 is materially inaccurate; or
 2. is of such a nature as to require a change in the Drawings or Specifications; or
 3. differs materially from that shown or indicated in the Contract Documents; or
 4. is of an unusual nature, and differs materially from conditions ordinarily encountered and generally recognized as inherent in work of the character provided for in the Contract Documents;
- then Contractor shall, promptly after becoming aware thereof and before further disturbing the subsurface or physical conditions or performing any Work in connection therewith (except in an emergency as required by Paragraph 7.15), notify Owner and Engineer in writing about such condition. Contractor shall not further disturb such condition or perform any Work in connection therewith (except with respect to an emergency) until receipt of a written statement permitting Contractor to do so.
- B. *Engineer's Review:* After receipt of written notice as required by the preceding paragraph, Engineer will promptly review the subsurface or physical condition in question; determine the necessity of Owner's obtaining additional exploration or tests with respect to the condition; conclude whether the condition falls within any one or more of the differing site condition categories in Paragraph 5.04.A above; obtain any pertinent cost or schedule information from Contractor; prepare recommendations to Owner regarding the Contractor's resumption of Work in connection with the subsurface or physical condition in question and the need for any change in the Drawings or Specifications; and advise Owner in writing of Engineer's findings, conclusions, and recommendations.
- C. *Owner's Statement to Contractor Regarding Site Condition:* After receipt of Engineer's written findings, conclusions, and recommendations, Owner shall issue a written statement to Contractor (with a copy to Engineer) regarding the subsurface or physical condition in question, addressing the resumption of Work in connection with such condition, indicating whether any change in the Drawings or Specifications will be made, and adopting or rejecting Engineer's written findings, conclusions, and recommendations, in whole or in part.
- D. *Possible Price and Times Adjustments:*
1. Contractor shall be entitled to an equitable adjustment in Contract Price or Contract Times, or both, to the extent that the existence of a differing subsurface or physical condition, or any related delay, disruption, or interference, causes an increase or decrease in Contractor's cost of, or time required for, performance of the Work; subject, however, to the following:
 - a. such condition must fall within any one or more of the categories described in Paragraph 5.04.A;
 - b. with respect to Work that is paid for on a unit price basis, any adjustment in Contract Price will be subject to the provisions of Paragraph 13.03; and,
 - c. Contractor's entitlement to an adjustment of the Contract Times is conditioned on such adjustment being essential to Contractor's ability to complete the Work within the Contract Times.

2. Contractor shall not be entitled to any adjustment in the Contract Price or Contract Times with respect to a subsurface or physical condition if:
 - a. Contractor knew of the existence of such condition at the time Contractor made a commitment to Owner with respect to Contract Price and Contract Times by the submission of a Bid or becoming bound under a negotiated contract, or otherwise; or
 - b. the existence of such condition reasonably could have been discovered or revealed as a result of any examination, investigation, exploration, test, or study of the Site and contiguous areas expressly required by the Bidding Requirements or Contract Documents to be conducted by or for Contractor prior to Contractor's making such commitment; or
 - c. Contractor failed to give the written notice as required by Paragraph 5.04.A.
3. If Owner and Contractor agree regarding Contractor's entitlement to and the amount or extent of any adjustment in the Contract Price or Contract Times, or both, then any such adjustment shall be set forth in a Change Order.
4. Contractor may submit a Change Proposal regarding its entitlement to or the amount or extent of any adjustment in the Contract Price or Contract Times, or both, no later than 30 days after Owner's issuance of the Owner's written statement to Contractor regarding the subsurface or physical condition in question.

5.05 Underground Facilities

- A. *Contractor's Responsibilities:* The information and data shown or indicated in the Contract Documents with respect to existing Underground Facilities at or adjacent to the Site is based on information and data furnished to Owner or Engineer by the owners of such Underground Facilities, including Owner, or by others. Unless it is otherwise expressly provided in the Supplementary Conditions:
 1. Owner and Engineer do not warrant or guarantee the accuracy or completeness of any such information or data provided by others; and
 2. the cost of all of the following will be included in the Contract Price, and Contractor shall have full responsibility for:
 - a. reviewing and checking all information and data regarding existing Underground Facilities at the Site;
 - b. locating all Underground Facilities shown or indicated in the Contract Documents as being at the Site;
 - c. coordination of the Work with the owners (including Owner) of such Underground Facilities, during construction; and
 - d. the safety and protection of all existing Underground Facilities at the Site, and repairing any damage thereto resulting from the Work.
- B. *Notice by Contractor:* If Contractor believes that an Underground Facility that is uncovered or revealed at the Site was not shown or indicated in the Contract Documents, or was not shown or indicated with reasonable accuracy, then Contractor shall, promptly after becoming aware thereof and before further disturbing conditions affected thereby or performing any Work in connection therewith (except in an emergency as required by Paragraph 7.15), identify the owner of such Underground Facility and give written notice to that owner and to Owner and Engineer.
- C. *Engineer's Review:* Engineer will promptly review the Underground Facility and conclude whether such Underground Facility was not shown or indicated in the Contract Documents, or was not shown or indicated with reasonable accuracy; obtain any pertinent cost or schedule information from Contractor; prepare recommendations to Owner regarding the Contractor's resumption of Work in connection with the Underground Facility in question; determine the extent, if any, to which a change is required in the Drawings or Specifications to reflect and document the consequences of the existence or location of the Underground Facility; and advise Owner in writing

EJCDC® -, Standard General Conditions of the Construction Contract.

Copyright © 2013 National Society of Professional Engineers, American Council of Engineering Companies, and American Society of Civil Engineers. All rights reserved.

of Engineer's findings, conclusions, and recommendations. During such time, Contractor shall be responsible for the safety and protection of such Underground Facility.

- D. *Owner's Statement to Contractor Regarding Underground Facility:* After receipt of Engineer's written findings, conclusions, and recommendations, Owner shall issue a written statement to Contractor (with a copy to Engineer) regarding the Underground Facility in question, addressing the resumption of Work in connection with such Underground Facility, indicating whether any change in the Drawings or Specifications will be made, and adopting or rejecting Engineer's written findings, conclusions, and recommendations in whole or in part.
- E. *Possible Price and Times Adjustments:*
1. Contractor shall be entitled to an equitable adjustment in the Contract Price or Contract Times, or both, to the extent that any existing Underground Facility at the Site that was not shown or indicated in the Contract Documents, or was not shown or indicated with reasonable accuracy, or any related delay, disruption, or interference, causes an increase or decrease in Contractor's cost of, or time required for, performance of the Work; subject, however, to the following:
 - a. Contractor did not know of and could not reasonably have been expected to be aware of or to have anticipated the existence or actual location of the Underground Facility in question;
 - b. With respect to Work that is paid for on a unit price basis, any adjustment in Contract Price will be subject to the provisions of Paragraph 13.03;
 - c. Contractor's entitlement to an adjustment of the Contract Times is conditioned on such adjustment being essential to Contractor's ability to complete the Work within the Contract Times; and
 - d. Contractor gave the notice required in Paragraph 5.05.B.
 2. If Owner and Contractor agree regarding Contractor's entitlement to and the amount or extent of any adjustment in the Contract Price or Contract Times, or both, then any such adjustment shall be set forth in a Change Order.
 3. Contractor may submit a Change Proposal regarding its entitlement to or the amount or extent of any adjustment in the Contract Price or Contract Times, or both, no later than 30 days after Owner's issuance of the Owner's written statement to Contractor regarding the Underground Facility in question.

5.06 Hazardous Environmental Conditions at Site

- A. *Reports and Drawings:* The Supplementary Conditions identify:
1. those reports and drawings known to Owner relating to Hazardous Environmental Conditions that have been identified at or adjacent to the Site; and
 2. Technical Data contained in such reports and drawings.
- B. *Reliance by Contractor on Technical Data Authorized:* Contractor may rely upon the accuracy of the Technical Data expressly identified in the Supplementary Conditions with respect to such reports and drawings, but such reports and drawings are not Contract Documents. If no such express identification has been made, then Contractor may rely on the accuracy of the Technical Data (as defined in Article 1) contained in any geotechnical or environmental report prepared for the Project and made available to Contractor. Except for such reliance on Technical Data, Contractor may not rely upon or make any claim against Owner or Engineer, or any of their officers, directors, members, partners, employees, agents, consultants, or subcontractors with respect to:
1. the completeness of such reports and drawings for Contractor's purposes, including, but not limited to, any aspects of the means, methods, techniques, sequences and procedures of construction to be employed by Contractor and safety precautions and programs incident thereto; or

2. other data, interpretations, opinions and information contained in such reports or shown or indicated in such drawings; or
 3. any Contractor interpretation of or conclusion drawn from any Technical Data or any such other data, interpretations, opinions or information.
- C. Contractor shall not be responsible for removing or remediating any Hazardous Environmental Condition encountered, uncovered, or revealed at the Site unless such removal or remediation is expressly identified in the Contract Documents to be within the scope of the Work.
 - D. Contractor shall be responsible for controlling, containing, and duly removing all Constituents of Concern brought to the Site by Contractor, Subcontractors, Suppliers, or anyone else for whom Contractor is responsible, and for any associated costs; and for the costs of removing and remediating any Hazardous Environmental Condition created by the presence of any such Constituents of Concern.
 - E. If Contractor encounters, uncovers, or reveals a Hazardous Environmental Condition whose removal or remediation is not expressly identified in the Contract Documents as being within the scope of the Work, or if Contractor or anyone for whom Contractor is responsible creates a Hazardous Environmental Condition, then Contractor shall immediately: (1) secure or otherwise isolate such condition; (2) stop all Work in connection with such condition and in any area affected thereby (except in an emergency as required by Paragraph 7.15); and (3) notify Owner and Engineer (and promptly thereafter confirm such notice in writing). Owner shall promptly consult with Engineer concerning the necessity for Owner to retain a qualified expert to evaluate such condition or take corrective action, if any. Promptly after consulting with Engineer, Owner shall take such actions as are necessary to permit Owner to timely obtain required permits and provide Contractor the written notice required by Paragraph 5.06.F. If Contractor or anyone for whom Contractor is responsible created the Hazardous Environmental Condition in question, then Owner may remove and remediate the Hazardous Environmental Condition, and impose a set-off against payments to account for the associated costs.
 - F. Contractor shall not resume Work in connection with such Hazardous Environmental Condition or in any affected area until after Owner has obtained any required permits related thereto, and delivered written notice to Contractor either (1) specifying that such condition and any affected area is or has been rendered safe for the resumption of Work, or (2) specifying any special conditions under which such Work may be resumed safely.
 - G. If Owner and Contractor cannot agree as to entitlement to or on the amount or extent, if any, of any adjustment in Contract Price or Contract Times, or both, as a result of such Work stoppage or such special conditions under which Work is agreed to be resumed by Contractor, then within 30 days of Owner's written notice regarding the resumption of Work, Contractor may submit a Change Proposal, or Owner may impose a set-off.
 - H. If after receipt of such written notice Contractor does not agree to resume such Work based on a reasonable belief it is unsafe, or does not agree to resume such Work under such special conditions, then Owner may order the portion of the Work that is in the area affected by such condition to be deleted from the Work, following the contractual change procedures in Article 11. Owner may have such deleted portion of the Work performed by Owner's own forces or others in accordance with Article 8.
 - I. To the fullest extent permitted by Laws and Regulations, Owner shall indemnify and hold harmless Contractor, Subcontractors, and Engineer, and the officers, directors, members, partners, employees, agents, consultants, and subcontractors of each and any of them from and against all claims, costs, losses, and damages (including but not limited to all fees and charges of engineers, architects, attorneys, and other professionals and all court or arbitration or other dispute resolution costs) arising out of or relating to a Hazardous Environmental Condition, provided that

EJCDC® - Standard General Conditions of the Construction Contract.

Copyright © 2013 National Society of Professional Engineers, American Council of Engineering Companies,
and American Society of Civil Engineers. All rights reserved.

such Hazardous Environmental Condition (1) was not shown or indicated in the Drawings, Specifications, or other Contract Documents, identified as Technical Data entitled to limited reliance pursuant to Paragraph 5.06.B, or identified in the Contract Documents to be included within the scope of the Work, and (2) was not created by Contractor or by anyone for whom Contractor is responsible. Nothing in this Paragraph 5.06.I shall obligate Owner to indemnify any individual or entity from and against the consequences of that individual's or entity's own negligence.

- J. To the fullest extent permitted by Laws and Regulations, Contractor shall indemnify and hold harmless Owner and Engineer, and the officers, directors, members, partners, employees, agents, consultants, and subcontractors of each and any of them from and against all claims, costs, losses, and damages (including but not limited to all fees and charges of engineers, architects, attorneys, and other professionals and all court or arbitration or other dispute resolution costs) arising out of or relating to the failure to control, contain, or remove a Constituent of Concern brought to the Site by Contractor or by anyone for whom Contractor is responsible, or to a Hazardous Environmental Condition created by Contractor or by anyone for whom Contractor is responsible. Nothing in this Paragraph 5.06.J shall obligate Contractor to indemnify any individual or entity from and against the consequences of that individual's or entity's own negligence.
- K. The provisions of Paragraphs 5.03, 5.04, and 5.05 do not apply to the presence of Constituents of Concern or to a Hazardous Environmental Condition uncovered or revealed at the Site.

ARTICLE 6 – BONDS AND INSURANCE

6.01 Performance, Payment, and Other Bonds

- A. Contractor shall furnish a performance bond and a payment bond, each in an amount at least equal to the Contract Price, as security for the faithful performance and payment of all of Contractor's obligations under the Contract. These bonds shall remain in effect until one year after the date when final payment becomes due or until completion of the correction period specified in Paragraph 15.08, whichever is later, except as provided otherwise by Laws or Regulations, the Supplementary Conditions, or other specific provisions of the Contract. Contractor shall also furnish such other bonds as are required by the Supplementary Conditions or other specific provisions of the Contract.
- B. All bonds shall be in the form prescribed by the Contract except as provided otherwise by Laws or Regulations, and shall be executed by such sureties as are named in "Companies Holding Certificates of Authority as Acceptable Sureties on Federal Bonds and as Acceptable Reinsuring Companies" as published in Circular 570 (as amended and supplemented) by the Financial Management Service, Surety Bond Branch, U.S. Department of the Treasury. A bond signed by an agent or attorney-in-fact must be accompanied by a certified copy of that individual's authority to bind the surety. The evidence of authority shall show that it is effective on the date the agent or attorney-in-fact signed the accompanying bond.
- C. Contractor shall obtain the required bonds from surety companies that are duly licensed or authorized in the jurisdiction in which the Project is located to issue bonds in the required amounts.
- D. If the surety on a bond furnished by Contractor is declared bankrupt or becomes insolvent, or its right to do business is terminated in any state or jurisdiction where any part of the Project is located, or the surety ceases to meet the requirements above, then Contractor shall promptly notify Owner and Engineer and shall, within 20 days after the event giving rise to such notification, provide another bond and surety, both of which shall comply with the bond and surety requirements above.

- E. If Contractor has failed to obtain a required bond, Owner may exclude the Contractor from the Site and exercise Owner's termination rights under Article 16.
- F. Upon request, Owner shall provide a copy of the payment bond to any Subcontractor, Supplier, or other person or entity claiming to have furnished labor or materials used in the performance of the Work.

6.02 Insurance—General Provisions

- A. Owner and Contractor shall obtain and maintain insurance as required in this Article and in the Supplementary Conditions.
- B. All insurance required by the Contract to be purchased and maintained by Owner or Contractor shall be obtained from insurance companies that are duly licensed or authorized, in the state or jurisdiction in which the Project is located, to issue insurance policies for the required limits and coverages. Unless a different standard is indicated in the Supplementary Conditions, all companies that provide insurance policies required under this Contract shall have an A.M. Best rating of A-VII or better.
- C. Contractor shall deliver to Owner, with copies to each named insured and additional insured (as identified in this Article, in the Supplementary Conditions, or elsewhere in the Contract), certificates of insurance establishing that Contractor has obtained and is maintaining the policies, coverages, and endorsements required by the Contract. Upon request by Owner or any other insured, Contractor shall also furnish other evidence of such required insurance, including but not limited to copies of policies and endorsements, and documentation of applicable self-insured retentions and deductibles. Contractor may block out (redact) any confidential premium or pricing information contained in any policy or endorsement furnished under this provision.
- D. Owner shall deliver to Contractor, with copies to each named insured and additional insured (as identified in this Article, the Supplementary Conditions, or elsewhere in the Contract), certificates of insurance establishing that Owner has obtained and is maintaining the policies, coverages, and endorsements required of Owner by the Contract (if any). Upon request by Contractor or any other insured, Owner shall also provide other evidence of such required insurance (if any), including but not limited to copies of policies and endorsements, and documentation of applicable self-insured retentions and deductibles. Owner may block out (redact) any confidential premium or pricing information contained in any policy or endorsement furnished under this provision.
- E. Failure of Owner or Contractor to demand such certificates or other evidence of the other party's full compliance with these insurance requirements, or failure of Owner or Contractor to identify a deficiency in compliance from the evidence provided, shall not be construed as a waiver of the other party's obligation to obtain and maintain such insurance.
- F. If either party does not purchase or maintain all of the insurance required of such party by the Contract, such party shall notify the other party in writing of such failure to purchase prior to the start of the Work, or of such failure to maintain prior to any change in the required coverage.
- G. If Contractor has failed to obtain and maintain required insurance, Owner may exclude the Contractor from the Site, impose an appropriate set-off against payment, and exercise Owner's termination rights under Article 16.
- H. Without prejudice to any other right or remedy, if a party has failed to obtain required insurance, the other party may elect to obtain equivalent insurance to protect such other party's interests at the expense of the party who was required to provide such coverage, and the Contract Price shall be adjusted accordingly.
- I. Owner does not represent that insurance coverage and limits established in this Contract necessarily will be adequate to protect Contractor or Contractor's interests.

- J. The insurance and insurance limits required herein shall not be deemed as a limitation on Contractor's liability under the indemnities granted to Owner and other individuals and entities in the Contract.
- 6.03 Contractor's Insurance
- A. *Workers' Compensation*: Contractor shall purchase and maintain workers' compensation and employer's liability insurance for:
1. claims under workers' compensation, disability benefits, and other similar employee benefit acts.
 2. United States Longshoreman and Harbor Workers' Compensation Act and Jones Act coverage (if applicable).
 3. claims for damages because of bodily injury, occupational sickness or disease, or death of Contractor's employees (by stop-gap endorsement in monopolist worker's compensation states).
 4. Foreign voluntary worker compensation (if applicable).
- B. *Commercial General Liability—Claims Covered*: Contractor shall purchase and maintain commercial general liability insurance, covering all operations by or on behalf of Contractor, on an occurrence basis, against:
1. claims for damages because of bodily injury, sickness or disease, or death of any person other than Contractor's employees.
 2. claims for damages insured by reasonably available personal injury liability coverage.
 3. claims for damages, other than to the Work itself, because of injury to or destruction of tangible property wherever located, including loss of use resulting therefrom.
- C. *Commercial General Liability—Form and Content*: Contractor's commercial liability policy shall be written on a 1996 (or later) ISO commercial general liability form (occurrence form) and include the following coverages and endorsements:
1. Products and completed operations coverage:
 - a. Such insurance shall be maintained for three years after final payment.
 - b. Contractor shall furnish Owner and each other additional insured (as identified in the Supplementary Conditions or elsewhere in the Contract) evidence of continuation of such insurance at final payment and three years thereafter.
 2. Blanket contractual liability coverage, to the extent permitted by law, including but not limited to coverage of Contractor's contractual indemnity obligations in Paragraph 7.18.
 3. Broad form property damage coverage.
 4. Severability of interest.
 5. Underground, explosion, and collapse coverage.
 6. Personal injury coverage.
 7. Additional insured endorsements that include both ongoing operations and products and completed operations coverage through ISO Endorsements CG 20 10 10 01 and CG 20 37 10 01 (together); or CG 20 10 07 04 and CG 20 37 07 04 (together); or their equivalent.
 8. For design professional additional insureds, ISO Endorsement CG 20 32 07 04, "Additional Insured—Engineers, Architects or Surveyors Not Engaged by the Named Insured" or its equivalent.
- D. *Automobile liability*: Contractor shall purchase and maintain automobile liability insurance against claims for damages because of bodily injury or death of any person or property damage arising out of the ownership, maintenance, or use of any motor vehicle. The automobile liability policy shall be written on an occurrence basis.
- E. *Umbrella or excess liability*: Contractor shall purchase and maintain umbrella or excess liability insurance written over the underlying employer's liability, commercial general liability, and

automobile liability insurance described in the paragraphs above. Subject to industry-standard exclusions, the coverage afforded shall follow form as to each and every one of the underlying policies.

- F. *Contractor's pollution liability insurance:* Contractor shall purchase and maintain a policy covering third-party injury and property damage claims, including clean-up costs, as a result of pollution conditions arising from Contractor's operations and completed operations. This insurance shall be maintained for no less than three years after final completion.
- G. *Additional insureds:* The Contractor's commercial general liability, automobile liability, umbrella or excess, and pollution liability policies shall include and list as additional insureds Owner and Engineer, and any individuals or entities identified in the Supplementary Conditions; include coverage for the respective officers, directors, members, partners, employees, agents, consultants, and subcontractors of each and any of all such additional insureds; and the insurance afforded to these additional insureds shall provide primary coverage for all claims covered thereby (including as applicable those arising from both ongoing and completed operations) on a non-contributory basis. Contractor shall obtain all necessary endorsements to support these requirements.
- H. *Contractor's professional liability insurance:* If Contractor will provide or furnish professional services under this Contract, through a delegation of professional design services or otherwise, then Contractor shall be responsible for purchasing and maintaining applicable professional liability insurance. This insurance shall provide protection against claims arising out of performance of professional design or related services, and caused by a negligent error, omission, or act for which the insured party is legally liable. It shall be maintained throughout the duration of the Contract and for a minimum of two years after Substantial Completion. If such professional design services are performed by a Subcontractor, and not by Contractor itself, then the requirements of this paragraph may be satisfied through the purchasing and maintenance of such insurance by such Subcontractor.
- I. *General provisions:* The policies of insurance required by this Paragraph 6.03 shall:
 - 1. include at least the specific coverages provided in this Article.
 - 2. be written for not less than the limits of liability provided in this Article and in the Supplementary Conditions, or required by Laws or Regulations, whichever is greater.
 - 3. contain a provision or endorsement that the coverage afforded will not be canceled, materially changed, or renewal refused until at least 10 days prior written notice has been given to Contractor. Within three days of receipt of any such written notice, Contractor shall provide a copy of the notice to Owner, Engineer, and each other insured under the policy.
 - 4. remain in effect at least until final payment (and longer if expressly required in this Article) and at all times thereafter when Contractor may be correcting, removing, or replacing defective Work as a warranty or correction obligation, or otherwise, or returning to the Site to conduct other tasks arising from the Contract Documents.
 - 5. be appropriate for the Work being performed and provide protection from claims that may arise out of or result from Contractor's performance of the Work and Contractor's other obligations under the Contract Documents, whether it is to be performed by Contractor, any Subcontractor or Supplier, or by anyone directly or indirectly employed by any of them to perform any of the Work, or by anyone for whose acts any of them may be liable.
- J. The coverage requirements for specific policies of insurance must be met by such policies, and not by reference to excess or umbrella insurance provided in other policies.

6.04 Owner's Liability Insurance

- A. In addition to the insurance required to be provided by Contractor under Paragraph 6.03, Owner, at Owner's option, may purchase and maintain at Owner's expense Owner's own liability insurance as will protect Owner against claims which may arise from operations under the Contract Documents.

EJCDC® -, Standard General Conditions of the Construction Contract.

Copyright © 2013 National Society of Professional Engineers, American Council of Engineering Companies, and American Society of Civil Engineers. All rights reserved.

- B. Owner's liability policies, if any, operate separately and independently from policies required to be provided by Contractor, and Contractor cannot rely upon Owner's liability policies for any of Contractor's obligations to the Owner, Engineer, or third parties.

6.05 Property Insurance

- A. *Builder's Risk*: Unless otherwise provided in the Supplementary Conditions, Contractor shall purchase and maintain builder's risk insurance upon the Work on a completed value basis, in the amount of the full insurable replacement cost thereof (subject to such deductible amounts as may be provided in the Supplementary Conditions or required by Laws and Regulations). This insurance shall:
1. include the Owner and Contractor as named insureds, and all Subcontractors, and any individuals or entities required by the Supplementary Conditions to be insured under such builder's risk policy, as insureds or named insureds. For purposes of the remainder of this Paragraph 6.05, Paragraphs 6.06 and 6.07, and any corresponding Supplementary Conditions, the parties required to be insured shall collectively be referred to as "insureds."
 2. be written on a builder's risk "all risk" policy form that shall at least include insurance for physical loss or damage to the Work, temporary buildings, falsework, and materials and equipment in transit, and shall insure against at least the following perils or causes of loss: fire; lightning; windstorm; riot; civil commotion; terrorism; vehicle impact; aircraft; smoke; theft; vandalism and malicious mischief; mechanical breakdown, boiler explosion, and artificially generated electric current; earthquake; volcanic activity, and other earth movement; flood; collapse; explosion; debris removal; demolition occasioned by enforcement of Laws and Regulations; water damage (other than that caused by flood); and such other perils or causes of loss as may be specifically required by the Supplementary Conditions. If insurance against mechanical breakdown, boiler explosion, and artificially generated electric current; earthquake; volcanic activity, and other earth movement; or flood, are not commercially available under builder's risk policies, by endorsement or otherwise, such insurance may be provided through other insurance policies acceptable to Owner and Contractor.
 3. cover, as insured property, at least the following: (a) the Work and all materials, supplies, machinery, apparatus, equipment, fixtures, and other property of a similar nature that are to be incorporated into or used in the preparation, fabrication, construction, erection, or completion of the Work, including Owner-furnished or assigned property; (b) spare parts inventory required within the scope of the Contract; and (c) temporary works which are not intended to form part of the permanent constructed Work but which are intended to provide working access to the Site, or to the Work under construction, or which are intended to provide temporary support for the Work under construction, including scaffolding, form work, fences, shoring, falsework, and temporary structures.
 4. cover expenses incurred in the repair or replacement of any insured property (including but not limited to fees and charges of engineers and architects).
 5. extend to cover damage or loss to insured property while in temporary storage at the Site or in a storage location outside the Site (but not including property stored at the premises of a manufacturer or Supplier).
 6. extend to cover damage or loss to insured property while in transit.
 7. allow for partial occupation or use of the Work by Owner, such that those portions of the Work that are not yet occupied or used by Owner shall remain covered by the builder's risk insurance.
 8. allow for the waiver of the insurer's subrogation rights, as set forth below.
 9. provide primary coverage for all losses and damages caused by the perils or causes of loss covered.

EJCDC® - Standard General Conditions of the Construction Contract.

Copyright © 2013 National Society of Professional Engineers, American Council of Engineering Companies, and American Society of Civil Engineers. All rights reserved.

10. not include a co-insurance clause.
 11. include an exception for ensuing losses from physical damage or loss with respect to any defective workmanship, design, or materials exclusions.
 12. include performance/hot testing and start-up.
 13. be maintained in effect, subject to the provisions herein regarding Substantial Completion and partial occupancy or use of the Work by Owner, until the Work is complete.
- B. *Notice of Cancellation or Change:* All the policies of insurance (and the certificates or other evidence thereof) required to be purchased and maintained in accordance with this Paragraph 6.05 will contain a provision or endorsement that the coverage afforded will not be canceled or materially changed or renewal refused until at least 10 days prior written notice has been given to the purchasing policyholder. Within three days of receipt of any such written notice, the purchasing policyholder shall provide a copy of the notice to each other insured.
- C. *Deductibles:* The purchaser of any required builder's risk or property insurance shall pay for costs not covered because of the application of a policy deductible.
- D. *Partial Occupancy or Use by Owner:* If Owner will occupy or use a portion or portions of the Work prior to Substantial Completion of all the Work as provided in Paragraph 15.04, then Owner (directly, if it is the purchaser of the builder's risk policy, or through Contractor) will provide notice of such occupancy or use to the builder's risk insurer. The builder's risk insurance shall not be canceled or permitted to lapse on account of any such partial use or occupancy; rather, those portions of the Work that are occupied or used by Owner may come off the builder's risk policy, while those portions of the Work not yet occupied or used by Owner shall remain covered by the builder's risk insurance.
- E. *Additional Insurance:* If Contractor elects to obtain other special insurance to be included in or supplement the builder's risk or property insurance policies provided under this Paragraph 6.05, it may do so at Contractor's expense.
- F. *Insurance of Other Property:* If the express insurance provisions of the Contract do not require or address the insurance of a property item or interest, such as tools, construction equipment, or other personal property owned by Contractor, a Subcontractor, or an employee of Contractor or a Subcontractor, then the entity or individual owning such property item will be responsible for deciding whether to insure it, and if so in what amount.

6.06 Waiver of Rights

- A. All policies purchased in accordance with Paragraph 6.05, expressly including the builder's risk policy, shall contain provisions to the effect that in the event of payment of any loss or damage the insurers will have no rights of recovery against any insureds thereunder, or against Engineer or its consultants, or their officers, directors, members, partners, employees, agents, consultants, or subcontractors. Owner and Contractor waive all rights against each other and the respective officers, directors, members, partners, employees, agents, consultants, and subcontractors of each and any of them, for all losses and damages caused by, arising out of, or resulting from any of the perils or causes of loss covered by such policies and any other property insurance applicable to the Work; and, in addition, waive all such rights against Engineer, its consultants, all Subcontractors, all individuals or entities identified in the Supplementary Conditions as insureds, and the officers, directors, members, partners, employees, agents, consultants, and subcontractors of each and any of them, under such policies for losses and damages so caused. None of the above waivers shall extend to the rights that any party making such waiver may have to the proceeds of insurance held by Owner or Contractor as trustee or fiduciary, or otherwise payable under any policy so issued.
- B. Owner waives all rights against Contractor, Subcontractors, and Engineer, and the officers, directors, members, partners, employees, agents, consultants and subcontractors of each and any of them, for:

EJCDC® -, Standard General Conditions of the Construction Contract.

Copyright © 2013 National Society of Professional Engineers, American Council of Engineering Companies, and American Society of Civil Engineers. All rights reserved.

1. loss due to business interruption, loss of use, or other consequential loss extending beyond direct physical loss or damage to Owner's property or the Work caused by, arising out of, or resulting from fire or other perils whether or not insured by Owner; and
 2. loss or damage to the completed Project or part thereof caused by, arising out of, or resulting from fire or other insured peril or cause of loss covered by any property insurance maintained on the completed Project or part thereof by Owner during partial occupancy or use pursuant to Paragraph 15.04, after Substantial Completion pursuant to Paragraph 15.03, or after final payment pursuant to Paragraph 15.06.
- C. Any insurance policy maintained by Owner covering any loss, damage or consequential loss referred to in Paragraph 6.06.B shall contain provisions to the effect that in the event of payment of any such loss, damage, or consequential loss, the insurers will have no rights of recovery against Contractor, Subcontractors, or Engineer, or the officers, directors, members, partners, employees, agents, consultants, or subcontractors of each and any of them.
 - D. Contractor shall be responsible for assuring that the agreement under which a Subcontractor performs a portion of the Work contains provisions whereby the Subcontractor waives all rights against Owner, Contractor, all individuals or entities identified in the Supplementary Conditions as insureds, the Engineer and its consultants, and the officers, directors, members, partners, employees, agents, consultants, and subcontractors of each and any of them, for all losses and damages caused by, arising out of, relating to, or resulting from any of the perils or causes of loss covered by builder's risk insurance and any other property insurance applicable to the Work.
- 6.07 Receipt and Application of Property Insurance Proceeds
- A. Any insured loss under the builder's risk and other policies of insurance required by Paragraph 6.05 will be adjusted and settled with the named insured that purchased the policy. Such named insured shall act as fiduciary for the other insureds, and give notice to such other insureds that adjustment and settlement of a claim is in progress. Any other insured may state its position regarding a claim for insured loss in writing within 15 days after notice of such claim.
 - B. Proceeds for such insured losses may be made payable by the insurer either jointly to multiple insureds, or to the named insured that purchased the policy in its own right and as fiduciary for other insureds, subject to the requirements of any applicable mortgage clause. A named insured receiving insurance proceeds under the builder's risk and other policies of insurance required by Paragraph 6.05 shall distribute such proceeds in accordance with such agreement as the parties in interest may reach, or as otherwise required under the dispute resolution provisions of this Contract or applicable Laws and Regulations.
 - C. If no other special agreement is reached, the damaged Work shall be repaired or replaced, the money so received applied on account thereof, and the Work and the cost thereof covered by Change Order, if needed.

ARTICLE 7 – CONTRACTOR'S RESPONSIBILITIES

7.01 Supervision and Superintendence

- A. Contractor shall supervise, inspect, and direct the Work competently and efficiently, devoting such attention thereto and applying such skills and expertise as may be necessary to perform the Work in accordance with the Contract Documents. Contractor shall be solely responsible for the means, methods, techniques, sequences, and procedures of construction.
- B. At all times during the progress of the Work, Contractor shall assign a competent resident superintendent who shall not be replaced without written notice to Owner and Engineer except under extraordinary circumstances.

7.02 Labor; Working Hours

- A. Contractor shall provide competent, suitably qualified personnel to survey and lay out the Work and perform construction as required by the Contract Documents. Contractor shall at all times maintain good discipline and order at the Site.
- B. Except as otherwise required for the safety or protection of persons or the Work or property at the Site or adjacent thereto, and except as otherwise stated in the Contract Documents, all Work at the Site shall be performed during regular working hours, Monday through Friday. Contractor will not perform Work on a Saturday, Sunday, or any legal holiday. Contractor may perform Work outside regular working hours or on Saturdays, Sundays, or legal holidays only with Owner's written consent, which will not be unreasonably withheld.

7.03 Services, Materials, and Equipment

- A. Unless otherwise specified in the Contract Documents, Contractor shall provide and assume full responsibility for all services, materials, equipment, labor, transportation, construction equipment and machinery, tools, appliances, fuel, power, light, heat, telephone, water, sanitary facilities, temporary facilities, and all other facilities and incidentals necessary for the performance, testing, start up, and completion of the Work, whether or not such items are specifically called for in the Contract Documents.
- B. All materials and equipment incorporated into the Work shall be of good quality and new, except as otherwise provided in the Contract Documents. All special warranties and guarantees required by the Specifications shall expressly run to the benefit of Owner. If required by Engineer, Contractor shall furnish satisfactory evidence (including reports of required tests) as to the source, kind, and quality of materials and equipment.
- C. All materials and equipment shall be stored, applied, installed, connected, erected, protected, used, cleaned, and conditioned in accordance with instructions of the applicable Supplier, except as otherwise may be provided in the Contract Documents.

7.04 "Or Equals"

- A. Whenever an item of material or equipment is specified or described in the Contract Documents by using the name of a proprietary item or the name of a particular Supplier, the Contract Price has been based upon Contractor furnishing such item as specified. The specification or description of such an item is intended to establish the type, function, appearance, and quality required. Unless the specification or description contains or is followed by words reading that no like, equivalent, or "or equal" item is permitted, Contractor may request that Engineer authorize the use of other items of material or equipment, or items from other proposed suppliers under the circumstances described below.
 - 1. If Engineer in its sole discretion determines that an item of material or equipment proposed by Contractor is functionally equal to that named and sufficiently similar so that no change in related Work will be required, Engineer shall deem it an "or equal" item. For the purposes of this paragraph, a proposed item of material or equipment will be considered functionally equal to an item so named if:
 - a. in the exercise of reasonable judgment Engineer determines that:
 - 1) it is at least equal in materials of construction, quality, durability, appearance, strength, and design characteristics;
 - 2) it will reliably perform at least equally well the function and achieve the results imposed by the design concept of the completed Project as a functioning whole;
 - 3) it has a proven record of performance and availability of responsive service; and
 - 4) it is not objectionable to Owner.
 - b. Contractor certifies that, if approved and incorporated into the Work:
 - 1) there will be no increase in cost to the Owner or increase in Contract Times; and

EJCDC® -, Standard General Conditions of the Construction Contract.

Copyright © 2013 National Society of Professional Engineers, American Council of Engineering Companies,
and American Society of Civil Engineers. All rights reserved.

- 2) it will conform substantially to the detailed requirements of the item named in the Contract Documents.
- B. *Contractor's Expense:* Contractor shall provide all data in support of any proposed "or equal" item at Contractor's expense.
- C. *Engineer's Evaluation and Determination:* Engineer will be allowed a reasonable time to evaluate each "or-equal" request. Engineer may require Contractor to furnish additional data about the proposed "or-equal" item. Engineer will be the sole judge of acceptability. No "or-equal" item will be ordered, furnished, installed, or utilized until Engineer's review is complete and Engineer determines that the proposed item is an "or-equal", which will be evidenced by an approved Shop Drawing or other written communication. Engineer will advise Contractor in writing of any negative determination.
- D. *Effect of Engineer's Determination:* Neither approval nor denial of an "or-equal" request shall result in any change in Contract Price. The Engineer's denial of an "or-equal" request shall be final and binding, and may not be reversed through an appeal under any provision of the Contract Documents.
- E. *Treatment as a Substitution Request:* If Engineer determines that an item of material or equipment proposed by Contractor does not qualify as an "or-equal" item, Contractor may request that Engineer considered the proposed item as a substitute pursuant to Paragraph 7.05.

7.05 Substitutes

- A. Unless the specification or description of an item of material or equipment required to be furnished under the Contract Documents contains or is followed by words reading that no substitution is permitted, Contractor may request that Engineer authorize the use of other items of material or equipment under the circumstances described below. To the extent possible such requests shall be made before commencement of related construction at the Site.
 1. Contractor shall submit sufficient information as provided below to allow Engineer to determine if the item of material or equipment proposed is functionally equivalent to that named and an acceptable substitute therefor. Engineer will not accept requests for review of proposed substitute items of material or equipment from anyone other than Contractor.
 2. The requirements for review by Engineer will be as set forth in Paragraph 7.05.B, as supplemented by the Specifications, and as Engineer may decide is appropriate under the circumstances.
 3. Contractor shall make written application to Engineer for review of a proposed substitute item of material or equipment that Contractor seeks to furnish or use. The application:
 - a. shall certify that the proposed substitute item will:
 - 1) perform adequately the functions and achieve the results called for by the general design,
 - 2) be similar in substance to that specified, and
 - 3) be suited to the same use as that specified.
 - b. will state:
 - 1) the extent, if any, to which the use of the proposed substitute item will necessitate a change in Contract Times,
 - 2) whether use of the proposed substitute item in the Work will require a change in any of the Contract Documents (or in the provisions of any other direct contract with Owner for other work on the Project) to adapt the design to the proposed substitute item, and
 - 3) whether incorporation or use of the proposed substitute item in connection with the Work is subject to payment of any license fee or royalty.

- c. will identify:
 - 1) all variations of the proposed substitute item from that specified, and
 - 2) available engineering, sales, maintenance, repair, and replacement services.
 - d. shall contain an itemized estimate of all costs or credits that will result directly or indirectly from use of such substitute item, including but not limited to changes in Contract Price, shared savings, costs of redesign, and claims of other contractors affected by any resulting change.
- B. *Engineer's Evaluation and Determination:* Engineer will be allowed a reasonable time to evaluate each substitute request, and to obtain comments and direction from Owner. Engineer may require Contractor to furnish additional data about the proposed substitute item. Engineer will be the sole judge of acceptability. No substitute will be ordered, furnished, installed, or utilized until Engineer's review is complete and Engineer determines that the proposed item is an acceptable substitute. Engineer's determination will be evidenced by a Field Order or a proposed Change Order accounting for the substitution itself and all related impacts, including changes in Contract Price or Contract Times. Engineer will advise Contractor in writing of any negative determination.
- C. *Special Guarantee:* Owner may require Contractor to furnish at Contractor's expense a special performance guarantee or other surety with respect to any substitute.
- D. *Reimbursement of Engineer's Cost:* Engineer will record Engineer's costs in evaluating a substitute proposed or submitted by Contractor. Whether or not Engineer approves a substitute so proposed or submitted by Contractor, Contractor shall reimburse Owner for the reasonable charges of Engineer for evaluating each such proposed substitute. Contractor shall also reimburse Owner for the reasonable charges of Engineer for making changes in the Contract Documents (or in the provisions of any other direct contract with Owner) resulting from the acceptance of each proposed substitute.
- E. *Contractor's Expense:* Contractor shall provide all data in support of any proposed substitute at Contractor's expense.
- F. *Effect of Engineer's Determination:* If Engineer approves the substitution request, Contractor shall execute the proposed Change Order and proceed with the substitution. The Engineer's denial of a substitution request shall be final and binding, and may not be reversed through an appeal under any provision of the Contract Documents. Contractor may challenge the scope of reimbursement costs imposed under Paragraph 7.05.D, by timely submittal of a Change Proposal.
- 7.06 Concerning Subcontractors, Suppliers, and Others
- A. Contractor may retain Subcontractors and Suppliers for the performance of parts of the Work. Such Subcontractors and Suppliers must be acceptable to Owner.
 - B. Contractor shall retain specific Subcontractors, Suppliers, or other individuals or entities for the performance of designated parts of the Work if required by the Contract to do so.
 - C. Subsequent to the submittal of Contractor's Bid or final negotiation of the terms of the Contract, Owner may not require Contractor to retain any Subcontractor, Supplier, or other individual or entity to furnish or perform any of the Work against which Contractor has reasonable objection.
 - D. Prior to entry into any binding subcontract or purchase order, Contractor shall submit to Owner the identity of the proposed Subcontractor or Supplier (unless Owner has already deemed such proposed Subcontractor or Supplier acceptable, during the bidding process or otherwise). Such proposed Subcontractor or Supplier shall be deemed acceptable to Owner unless Owner raises a substantive, reasonable objection within five days.
 - E. Owner may require the replacement of any Subcontractor, Supplier, or other individual or entity retained by Contractor to perform any part of the Work. Owner also may require Contractor to retain specific replacements; provided, however, that Owner may not require a replacement to which Contractor has a reasonable objection. If Contractor has submitted the identity of certain

EJCDC® -, Standard General Conditions of the Construction Contract.

Copyright © 2013 National Society of Professional Engineers, American Council of Engineering Companies, and American Society of Civil Engineers. All rights reserved.

Subcontractors, Suppliers, or other individuals or entities for acceptance by Owner, and Owner has accepted it (either in writing or by failing to make written objection thereto), then Owner may subsequently revoke the acceptance of any such Subcontractor, Supplier, or other individual or entity so identified solely on the basis of substantive, reasonable objection after due investigation. Contractor shall submit an acceptable replacement for the rejected Subcontractor, Supplier, or other individual or entity.

- F. If Owner requires the replacement of any Subcontractor, Supplier, or other individual or entity retained by Contractor to perform any part of the Work, then Contractor shall be entitled to an adjustment in Contract Price or Contract Times, or both, with respect to the replacement; and Contractor shall initiate a Change Proposal for such adjustment within 30 days of Owner's requirement of replacement.
- G. No acceptance by Owner of any such Subcontractor, Supplier, or other individual or entity, whether initially or as a replacement, shall constitute a waiver of the right of Owner to the completion of the Work in accordance with the Contract Documents.
- H. On a monthly basis Contractor shall submit to Engineer a complete list of all Subcontractors and Suppliers having a direct contract with Contractor, and of all other Subcontractors and Suppliers known to Contractor at the time of submittal.
- I. Contractor shall be fully responsible to Owner and Engineer for all acts and omissions of the Subcontractors, Suppliers, and other individuals or entities performing or furnishing any of the Work just as Contractor is responsible for Contractor's own acts and omissions.
- J. Contractor shall be solely responsible for scheduling and coordinating the work of Subcontractors, Suppliers, and all other individuals or entities performing or furnishing any of the Work.
- K. Contractor shall restrict all Subcontractors, Suppliers, and such other individuals or entities performing or furnishing any of the Work from communicating with Engineer or Owner, except through Contractor or in case of an emergency, or as otherwise expressly allowed herein.
- L. The divisions and sections of the Specifications and the identifications of any Drawings shall not control Contractor in dividing the Work among Subcontractors or Suppliers or delineating the Work to be performed by any specific trade.
- M. All Work performed for Contractor by a Subcontractor or Supplier shall be pursuant to an appropriate contractual agreement that specifically binds the Subcontractor or Supplier to the applicable terms and conditions of the Contract Documents for the benefit of Owner and Engineer.
- N. Owner may furnish to any Subcontractor or Supplier, to the extent practicable, information about amounts paid to Contractor on account of Work performed for Contractor by the particular Subcontractor or Supplier.
- O. Nothing in the Contract Documents:
 - 1. shall create for the benefit of any such Subcontractor, Supplier, or other individual or entity any contractual relationship between Owner or Engineer and any such Subcontractor, Supplier, or other individual or entity; nor
 - 2. shall create any obligation on the part of Owner or Engineer to pay or to see to the payment of any money due any such Subcontractor, Supplier, or other individual or entity except as may otherwise be required by Laws and Regulations.

7.07 Patent Fees and Royalties

- A. Contractor shall pay all license fees and royalties and assume all costs incident to the use in the performance of the Work or the incorporation in the Work of any invention, design, process, product, or device which is the subject of patent rights or copyrights held by others. If a particular invention, design, process, product, or device is specified in the Contract Documents for use in the performance of the Work and if, to the actual knowledge of Owner or Engineer, its use is subject to

patent rights or copyrights calling for the payment of any license fee or royalty to others, the existence of such rights shall be disclosed by Owner in the Contract Documents.

- B. To the fullest extent permitted by Laws and Regulations, Owner shall indemnify and hold harmless Contractor, and its officers, directors, members, partners, employees, agents, consultants, and subcontractors from and against all claims, costs, losses, and damages (including but not limited to all fees and charges of engineers, architects, attorneys, and other professionals, and all court or arbitration or other dispute resolution costs) arising out of or relating to any infringement of patent rights or copyrights incident to the use in the performance of the Work or resulting from the incorporation in the Work of any invention, design, process, product, or device specified in the Contract Documents, but not identified as being subject to payment of any license fee or royalty to others required by patent rights or copyrights.
- C. To the fullest extent permitted by Laws and Regulations, Contractor shall indemnify and hold harmless Owner and Engineer, and the officers, directors, members, partners, employees, agents, consultants and subcontractors of each and any of them from and against all claims, costs, losses, and damages (including but not limited to all fees and charges of engineers, architects, attorneys, and other professionals and all court or arbitration or other dispute resolution costs) arising out of or relating to any infringement of patent rights or copyrights incident to the use in the performance of the Work or resulting from the incorporation in the Work of any invention, design, process, product, or device not specified in the Contract Documents.

7.08 Permits

- A. Unless otherwise provided in the Contract Documents, Contractor shall obtain and pay for all construction permits and licenses. Owner shall assist Contractor, when necessary, in obtaining such permits and licenses. Contractor shall pay all governmental charges and inspection fees necessary for the prosecution of the Work which are applicable at the time of the submission of Contractor's Bid (or when Contractor became bound under a negotiated contract). Owner shall pay all charges of utility owners for connections for providing permanent service to the Work

7.09 Taxes

- A. Contractor shall pay all sales, consumer, use, and other similar taxes required to be paid by Contractor in accordance with the Laws and Regulations of the place of the Project which are applicable during the performance of the Work.

7.10 Laws and Regulations

- A. Contractor shall give all notices required by and shall comply with all Laws and Regulations applicable to the performance of the Work. Except where otherwise expressly required by applicable Laws and Regulations, neither Owner nor Engineer shall be responsible for monitoring Contractor's compliance with any Laws or Regulations.
- B. If Contractor performs any Work or takes any other action knowing or having reason to know that it is contrary to Laws or Regulations, Contractor shall bear all resulting costs and losses, and shall indemnify and hold harmless Owner and Engineer, and the officers, directors, members, partners, employees, agents, consultants, and subcontractors of each and any of them from and against all claims, costs, losses, and damages (including but not limited to all fees and charges of engineers, architects, attorneys, and other professionals and all court or arbitration or other dispute resolution costs) arising out of or relating to such Work or other action. It shall not be Contractor's responsibility to make certain that the Work described in the Contract Documents is in accordance with Laws and Regulations, but this shall not relieve Contractor of Contractor's obligations under Paragraph 3.03.
- C. Owner or Contractor may give notice to the other party of any changes after the submission of Contractor's Bid (or after the date when Contractor became bound under a negotiated contract) in Laws or Regulations having an effect on the cost or time of performance of the Work, including but

EJCDC® - Standard General Conditions of the Construction Contract.

Copyright © 2013 National Society of Professional Engineers, American Council of Engineering Companies, and American Society of Civil Engineers. All rights reserved.

not limited to changes in Laws or Regulations having an effect on procuring permits and on sales, use, value-added, consumption, and other similar taxes. If Owner and Contractor are unable to agree on entitlement to or on the amount or extent, if any, of any adjustment in Contract Price or Contract Times resulting from such changes, then within 30 days of such notice Contractor may submit a Change Proposal, or Owner may initiate a Claim.

7.11 Record Documents

- A. Contractor shall maintain in a safe place at the Site one printed record copy of all Drawings, Specifications, Addenda, Change Orders, Work Change Directives, Field Orders, written interpretations and clarifications, and approved Shop Drawings. Contractor shall keep such record documents in good order and annotate them to show changes made during construction. These record documents, together with all approved Samples, will be available to Engineer for reference. Upon completion of the Work, Contractor shall deliver these record documents to Engineer.

7.12 Safety and Protection

- A. Contractor shall be solely responsible for initiating, maintaining, and supervising all safety precautions and programs in connection with the Work. Such responsibility does not relieve Subcontractors of their responsibility for the safety of persons or property in the performance of their work, nor for compliance with applicable safety Laws and Regulations. Contractor shall take all necessary precautions for the safety of, and shall provide the necessary protection to prevent damage, injury, or loss to:
1. all persons on the Site or who may be affected by the Work;
 2. all the Work and materials and equipment to be incorporated therein, whether in storage on or off the Site; and
 3. other property at the Site or adjacent thereto, including trees, shrubs, lawns, walks, pavements, roadways, structures, other work in progress, utilities, and Underground Facilities not designated for removal, relocation, or replacement in the course of construction.
- B. Contractor shall comply with all applicable Laws and Regulations relating to the safety of persons or property, or to the protection of persons or property from damage, injury, or loss; and shall erect and maintain all necessary safeguards for such safety and protection. Contractor shall notify Owner; the owners of adjacent property, Underground Facilities, and other utilities; and other contractors and utility owners performing work at or adjacent to the Site, when prosecution of the Work may affect them, and shall cooperate with them in the protection, removal, relocation, and replacement of their property or work in progress.
- C. Contractor shall comply with the applicable requirements of Owner's safety programs, if any. The Supplementary Conditions identify any Owner's safety programs that are applicable to the Work.
- D. Contractor shall inform Owner and Engineer of the specific requirements of Contractor's safety program with which Owner's and Engineer's employees and representatives must comply while at the Site.
- E. All damage, injury, or loss to any property referred to in Paragraph 7.12.A.2 or 7.12.A.3 caused, directly or indirectly, in whole or in part, by Contractor, any Subcontractor, Supplier, or any other individual or entity directly or indirectly employed by any of them to perform any of the Work, or anyone for whose acts any of them may be liable, shall be remedied by Contractor at its expense (except damage or loss attributable to the fault of Drawings or Specifications or to the acts or omissions of Owner or Engineer or anyone employed by any of them, or anyone for whose acts any of them may be liable, and not attributable, directly or indirectly, in whole or in part, to the fault or negligence of Contractor or any Subcontractor, Supplier, or other individual or entity directly or indirectly employed by any of them).
- F. Contractor's duties and responsibilities for safety and protection shall continue until such time as all the Work is completed and Engineer has issued a notice to Owner and Contractor in accordance

with Paragraph 15.06.B that the Work is acceptable (except as otherwise expressly provided in connection with Substantial Completion).

- G. Contractor's duties and responsibilities for safety and protection shall resume whenever Contractor or any Subcontractor or Supplier returns to the Site to fulfill warranty or correction obligations, or to conduct other tasks arising from the Contract Documents.

7.13 Safety Representative

- A. Contractor shall designate a qualified and experienced safety representative at the Site whose duties and responsibilities shall be the prevention of accidents and the maintaining and supervising of safety precautions and programs.

7.14 Hazard Communication Programs

- A. Contractor shall be responsible for coordinating any exchange of material safety data sheets or other hazard communication information required to be made available to or exchanged between or among employers at the Site in accordance with Laws or Regulations.

7.15 Emergencies

- A. In emergencies affecting the safety or protection of persons or the Work or property at the Site or adjacent thereto, Contractor is obligated to act to prevent threatened damage, injury, or loss. Contractor shall give Engineer prompt written notice if Contractor believes that any significant changes in the Work or variations from the Contract Documents have been caused thereby or are required as a result thereof. If Engineer determines that a change in the Contract Documents is required because of the action taken by Contractor in response to such an emergency, a Work Change Directive or Change Order will be issued.

7.16 Shop Drawings, Samples, and Other Submittals

- A. *Shop Drawing and Sample Submittal Requirements:*

1. Before submitting a Shop Drawing or Sample, Contractor shall have:
 - a. reviewed and coordinated the Shop Drawing or Sample with other Shop Drawings and Samples and with the requirements of the Work and the Contract Documents;
 - b. determined and verified all field measurements, quantities, dimensions, specified performance and design criteria, installation requirements, materials, catalog numbers, and similar information with respect thereto;
 - c. determined and verified the suitability of all materials and equipment offered with respect to the indicated application, fabrication, shipping, handling, storage, assembly, and installation pertaining to the performance of the Work; and
 - d. determined and verified all information relative to Contractor's responsibilities for means, methods, techniques, sequences, and procedures of construction, and safety precautions and programs incident thereto.
 2. Each submittal shall bear a stamp or specific written certification that Contractor has satisfied Contractor's obligations under the Contract Documents with respect to Contractor's review of that submittal, and that Contractor approves the submittal.
 3. With each submittal, Contractor shall give Engineer specific written notice of any variations that the Shop Drawing or Sample may have from the requirements of the Contract Documents. This notice shall be set forth in a written communication separate from the Shop Drawings or Sample submittal; and, in addition, in the case of Shop Drawings by a specific notation made on each Shop Drawing submitted to Engineer for review and approval of each such variation.
- B. *Submittal Procedures for Shop Drawings and Samples:* Contractor shall submit Shop Drawings and Samples to Engineer for review and approval in accordance with the accepted Schedule of Submittals. Each submittal will be identified as Engineer may require.

1. *Shop Drawings:*

- a. Contractor shall submit the number of copies required in the Specifications.

EJCDC® -, Standard General Conditions of the Construction Contract.

Copyright © 2013 National Society of Professional Engineers, American Council of Engineering Companies,
and American Society of Civil Engineers. All rights reserved.

- b. Data shown on the Shop Drawings will be complete with respect to quantities, dimensions, specified performance and design criteria, materials, and similar data to show Engineer the services, materials, and equipment Contractor proposes to provide and to enable Engineer to review the information for the limited purposes required by Paragraph 7.16.D.
 2. *Samples:*
 - a. Contractor shall submit the number of Samples required in the Specifications.
 - b. Contractor shall clearly identify each Sample as to material, Supplier, pertinent data such as catalog numbers, the use for which intended and other data as Engineer may require to enable Engineer to review the submittal for the limited purposes required by Paragraph 7.16.D.
 3. Where a Shop Drawing or Sample is required by the Contract Documents or the Schedule of Submittals, any related Work performed prior to Engineer's review and approval of the pertinent submittal will be at the sole expense and responsibility of Contractor.
- C. *Other Submittals:* Contractor shall submit other submittals to Engineer in accordance with the accepted Schedule of Submittals, and pursuant to the applicable terms of the Specifications.
- D. *Engineer's Review:*
 1. Engineer will provide timely review of Shop Drawings and Samples in accordance with the Schedule of Submittals acceptable to Engineer. Engineer's review and approval will be only to determine if the items covered by the submittals will, after installation or incorporation in the Work, conform to the information given in the Contract Documents and be compatible with the design concept of the completed Project as a functioning whole as indicated by the Contract Documents.
 2. Engineer's review and approval will not extend to means, methods, techniques, sequences, or procedures of construction or to safety precautions or programs incident thereto.
 3. Engineer's review and approval of a separate item as such will not indicate approval of the assembly in which the item functions.
 4. Engineer's review and approval of a Shop Drawing or Sample shall not relieve Contractor from responsibility for any variation from the requirements of the Contract Documents unless Contractor has complied with the requirements of Paragraph 7.16.A.3 and Engineer has given written approval of each such variation by specific written notation thereof incorporated in or accompanying the Shop Drawing or Sample. Engineer will document any such approved variation from the requirements of the Contract Documents in a Field Order.
 5. Engineer's review and approval of a Shop Drawing or Sample shall not relieve Contractor from responsibility for complying with the requirements of Paragraph 7.16.A and B.
 6. Engineer's review and approval of a Shop Drawing or Sample, or of a variation from the requirements of the Contract Documents, shall not, under any circumstances, change the Contract Times or Contract Price, unless such changes are included in a Change Order.
 7. Neither Engineer's receipt, review, acceptance or approval of a Shop Drawing, Sample, or other submittal shall result in such item becoming a Contract Document.
 8. Contractor shall perform the Work in compliance with the requirements and commitments set forth in approved Shop Drawings and Samples, subject to the provisions of Paragraph 7.16.D.4.
- E. *Resubmittal Procedures:*
 1. Contractor shall make corrections required by Engineer and shall return the required number of corrected copies of Shop Drawings and submit, as required, new Samples for review and approval. Contractor shall direct specific attention in writing to revisions other than the corrections called for by Engineer on previous submittals.

2. Contractor shall furnish required submittals with sufficient information and accuracy to obtain required approval of an item with no more than three submittals. Engineer will record Engineer's time for reviewing a fourth or subsequent submittal of a Shop Drawings, sample, or other item requiring approval, and Contractor shall be responsible for Engineer's charges to Owner for such time. Owner may impose a set-off against payments due to Contractor to secure reimbursement for such charges.
3. If Contractor requests a change of a previously approved submittal item, Contractor shall be responsible for Engineer's charges to Owner for its review time, and Owner may impose a set-off against payments due to Contractor to secure reimbursement for such charges, unless the need for such change is beyond the control of Contractor.

7.17 Contractor's General Warranty and Guarantee

- A. Contractor warrants and guarantees to Owner that all Work will be in accordance with the Contract Documents and will not be defective. Engineer and its officers, directors, members, partners, employees, agents, consultants, and subcontractors shall be entitled to rely on Contractor's warranty and guarantee.
- B. Contractor's warranty and guarantee hereunder excludes defects or damage caused by:
 1. abuse, modification, or improper maintenance or operation by persons other than Contractor, Subcontractors, Suppliers, or any other individual or entity for whom Contractor is responsible; or
 2. normal wear and tear under normal usage.
- C. Contractor's obligation to perform and complete the Work in accordance with the Contract Documents shall be absolute. None of the following will constitute an acceptance of Work that is not in accordance with the Contract Documents or a release of Contractor's obligation to perform the Work in accordance with the Contract Documents:
 1. observations by Engineer;
 2. recommendation by Engineer or payment by Owner of any progress or final payment;
 3. the issuance of a certificate of Substantial Completion by Engineer or any payment related thereto by Owner;
 4. use or occupancy of the Work or any part thereof by Owner;
 5. any review and approval of a Shop Drawing or Sample submittal;
 6. the issuance of a notice of acceptability by Engineer;
 7. any inspection, test, or approval by others; or
 8. any correction of defective Work by Owner.
- D. If the Contract requires the Contractor to accept the assignment of a contract entered into by Owner, then the specific warranties, guarantees, and correction obligations contained in the assigned contract shall govern with respect to Contractor's performance obligations to Owner for the Work described in the assigned contract.

7.18 Indemnification

- A. To the fullest extent permitted by Laws and Regulations, and in addition to any other obligations of Contractor under the Contract or otherwise, Contractor shall indemnify and hold harmless Owner and Engineer, and the officers, directors, members, partners, employees, agents, consultants and subcontractors of each and any of them from and against all claims, costs, losses, and damages (including but not limited to all fees and charges of engineers, architects, attorneys, and other professionals and all court or arbitration or other dispute resolution costs) arising out of or relating to the performance of the Work, provided that any such claim, cost, loss, or damage is attributable to bodily injury, sickness, disease, or death, or to injury to or destruction of tangible property (other than the Work itself), including the loss of use resulting therefrom but only to the extent caused by any negligent act or omission of Contractor, any Subcontractor, any Supplier, or any individual or

EJCDC® - Standard General Conditions of the Construction Contract.

Copyright © 2013 National Society of Professional Engineers, American Council of Engineering Companies, and American Society of Civil Engineers. All rights reserved.

entity directly or indirectly employed by any of them to perform any of the Work or anyone for whose acts any of them may be liable.

- B. In any and all claims against Owner or Engineer or any of their officers, directors, members, partners, employees, agents, consultants, or subcontractors by any employee (or the survivor or personal representative of such employee) of Contractor, any Subcontractor, any Supplier, or any individual or entity directly or indirectly employed by any of them to perform any of the Work, or anyone for whose acts any of them may be liable, the indemnification obligation under Paragraph 7.18.A shall not be limited in any way by any limitation on the amount or type of damages, compensation, or benefits payable by or for Contractor or any such Subcontractor, Supplier, or other individual or entity under workers' compensation acts, disability benefit acts, or other employee benefit acts.
- C. The indemnification obligations of Contractor under Paragraph 7.18.A shall not extend to the liability of Engineer and Engineer's officers, directors, members, partners, employees, agents, consultants and subcontractors arising out of:
 - 1. the preparation or approval of, or the failure to prepare or approve maps, Drawings, opinions, reports, surveys, Change Orders, designs, or Specifications; or
 - 2. giving directions or instructions, or failing to give them, if that is the primary cause of the injury or damage.

7.19 Delegation of Professional Design Services

- A. Contractor will not be required to provide professional design services unless such services are specifically required by the Contract Documents for a portion of the Work or unless such services are required to carry out Contractor's responsibilities for construction means, methods, techniques, sequences and procedures. Contractor shall not be required to provide professional services in violation of applicable Laws and Regulations.
- B. If professional design services or certifications by a design professional related to systems, materials, or equipment are specifically required of Contractor by the Contract Documents, Owner and Engineer will specify all performance and design criteria that such services must satisfy. Contractor shall cause such services or certifications to be provided by a properly licensed professional, whose signature and seal shall appear on all drawings, calculations, specifications, certifications, and other submittals prepared by such professional. Shop Drawings and other submittals related to the Work designed or certified by such professional, if prepared by others, shall bear such professional's written approval when submitted to Engineer.
- C. Owner and Engineer shall be entitled to rely upon the adequacy, accuracy, and completeness of the services, certifications, or approvals performed by such design professionals, provided Owner and Engineer have specified to Contractor all performance and design criteria that such services must satisfy.
- D. Pursuant to this paragraph, Engineer's review and approval of design calculations and design drawings will be only for the limited purpose of checking for conformance with performance and design criteria given and the design concept expressed in the Contract Documents. Engineer's review and approval of Shop Drawings and other submittals (except design calculations and design drawings) will be only for the purpose stated in Paragraph 7.16.D.1.
- E. Contractor shall not be responsible for the adequacy of the performance or design criteria specified by Owner or Engineer.

ARTICLE 8 – OTHER WORK AT THE SITE**8.01 Other Work**

- A. In addition to and apart from the Work under the Contract Documents, the Owner may perform other work at or adjacent to the Site. Such other work may be performed by Owner's employees, or through contracts between the Owner and third parties. Owner may also arrange to have third-party utility owners perform work on their utilities and facilities at or adjacent to the Site.
- B. If Owner performs other work at or adjacent to the Site with Owner's employees, or through contracts for such other work, then Owner shall give Contractor written notice thereof prior to starting any such other work. If Owner has advance information regarding the start of any utility work at or adjacent to the Site, Owner shall provide such information to Contractor.
- C. Contractor shall afford each other contractor that performs such other work, each utility owner performing other work, and Owner, if Owner is performing other work with Owner's employees, proper and safe access to the Site, and provide a reasonable opportunity for the introduction and storage of materials and equipment and the execution of such other work. Contractor shall do all cutting, fitting, and patching of the Work that may be required to properly connect or otherwise make its several parts come together and properly integrate with such other work. Contractor shall not endanger any work of others by cutting, excavating, or otherwise altering such work; provided, however, that Contractor may cut or alter others' work with the written consent of Engineer and the others whose work will be affected.
- D. If the proper execution or results of any part of Contractor's Work depends upon work performed by others under this Article 8, Contractor shall inspect such other work and promptly report to Engineer in writing any delays, defects, or deficiencies in such other work that render it unavailable or unsuitable for the proper execution and results of Contractor's Work. Contractor's failure to so report will constitute an acceptance of such other work as fit and proper for integration with Contractor's Work except for latent defects and deficiencies in such other work.

8.02 Coordination

- A. If Owner intends to contract with others for the performance of other work at or adjacent to the Site, to perform other work at or adjacent to the Site with Owner's employees, or to arrange to have utility owners perform work at or adjacent to the Site, the following will be set forth in the Supplementary Conditions or provided to Contractor prior to the start of any such other work:
 - 1. the identity of the individual or entity that will have authority and responsibility for coordination of the activities among the various contractors;
 - 2. an itemization of the specific matters to be covered by such authority and responsibility; and
 - 3. the extent of such authority and responsibilities.
- B. Unless otherwise provided in the Supplementary Conditions, Owner shall have sole authority and responsibility for such coordination.

8.03 Legal Relationships

- A. If, in the course of performing other work at or adjacent to the Site for Owner, the Owner's employees, any other contractor working for Owner, or any utility owner for whom the Owner is responsible causes damage to the Work or to the property of Contractor or its Subcontractors, or delays, disrupts, interferes with, or increases the scope or cost of the performance of the Work, through actions or inaction, then Contractor shall be entitled to an equitable adjustment in the Contract Price or the Contract Times, or both. Contractor must submit any Change Proposal seeking an equitable adjustment in the Contract Price or the Contract Times under this paragraph within 30 days of the damaging, delaying, disrupting, or interfering event. The entitlement to, and extent of, any such equitable adjustment shall take into account information (if any) regarding such other work that was provided to Contractor in the Contract Documents prior to the submittal of the Bid

or the final negotiation of the terms of the Contract. When applicable, any such equitable adjustment in Contract Price shall be conditioned on Contractor assigning to Owner all Contractor's rights against such other contractor or utility owner with respect to the damage, delay, disruption, or interference that is the subject of the adjustment. Contractor's entitlement to an adjustment of the Contract Times is conditioned on such adjustment being essential to Contractor's ability to complete the Work within the Contract Times.

- B. Contractor shall take reasonable and customary measures to avoid damaging, delaying, disrupting, or interfering with the work of Owner, any other contractor, or any utility owner performing other work at or adjacent to the Site. If Contractor fails to take such measures and as a result damages, delays, disrupts, or interferes with the work of any such other contractor or utility owner, then Owner may impose a set-off against payments due to Contractor, and assign to such other contractor or utility owner the Owner's contractual rights against Contractor with respect to the breach of the obligations set forth in this paragraph.
- C. When Owner is performing other work at or adjacent to the Site with Owner's employees, Contractor shall be liable to Owner for damage to such other work, and for the reasonable direct delay, disruption, and interference costs incurred by Owner as a result of Contractor's failure to take reasonable and customary measures with respect to Owner's other work. In response to such damage, delay, disruption, or interference, Owner may impose a set-off against payments due to Contractor.
- D. If Contractor damages, delays, disrupts, or interferes with the work of any other contractor, or any utility owner performing other work at or adjacent to the Site, through Contractor's failure to take reasonable and customary measures to avoid such impacts, or if any claim arising out of Contractor's actions, inactions, or negligence in performance of the Work at or adjacent to the Site is made by any such other contractor or utility owner against Contractor, Owner, or Engineer, then Contractor shall (1) promptly attempt to settle the claim as to all parties through negotiations with such other contractor or utility owner, or otherwise resolve the claim by arbitration or other dispute resolution proceeding or at law, and (2) indemnify and hold harmless Owner and Engineer, and the officers, directors, members, partners, employees, agents, consultants and subcontractors of each and any of them from and against any such claims, and against all costs, losses, and damages (including but not limited to all fees and charges of engineers, architects, attorneys, and other professionals and all court or arbitration or other dispute resolution costs) arising out of or relating to such damage, delay, disruption, or interference.

ARTICLE 9 – OWNER'S RESPONSIBILITIES

9.01 Communications to Contractor

- A. Except as otherwise provided in these General Conditions, Owner shall issue all communications to Contractor through Engineer.

9.02 Replacement of Engineer

- A. Owner may at its discretion appoint an engineer to replace Engineer, provided Contractor makes no reasonable objection to the replacement engineer. The replacement engineer's status under the Contract Documents shall be that of the former Engineer.

9.03 Furnish Data

- A. Owner shall promptly furnish the data required of Owner under the Contract Documents.

9.04 Pay When Due

- A. Owner shall make payments to Contractor when they are due as provided in the Agreement.

9.05 Lands and Easements; Reports, Tests, and Drawings

- A. Owner's duties with respect to providing lands and easements are set forth in Paragraph 5.01.

EJCDC® -, Standard General Conditions of the Construction Contract.

Copyright © 2013 National Society of Professional Engineers, American Council of Engineering Companies,
and American Society of Civil Engineers. All rights reserved.

- B. Owner's duties with respect to providing engineering surveys to establish reference points are set forth in Paragraph 4.03.
 - C. Article 5 refers to Owner's identifying and making available to Contractor copies of reports of explorations and tests of conditions at the Site, and drawings of physical conditions relating to existing surface or subsurface structures at the Site.
- 9.06 Insurance
- A. Owner's responsibilities, if any, with respect to purchasing and maintaining liability and property insurance are set forth in Article 6.
- 9.07 Change Orders
- A. Owner's responsibilities with respect to Change Orders are set forth in Article 11.
- 9.08 Inspections, Tests, and Approvals
- A. Owner's responsibility with respect to certain inspections, tests, and approvals is set forth in Paragraph 14.02.B.
- 9.09 Limitations on Owner's Responsibilities
- A. The Owner shall not supervise, direct, or have control or authority over, nor be responsible for, Contractor's means, methods, techniques, sequences, or procedures of construction, or the safety precautions and programs incident thereto, or for any failure of Contractor to comply with Laws and Regulations applicable to the performance of the Work. Owner will not be responsible for Contractor's failure to perform the Work in accordance with the Contract Documents.
- 9.10 Undisclosed Hazardous Environmental Condition
- A. Owner's responsibility in respect to an undisclosed Hazardous Environmental Condition is set forth in Paragraph 5.06.
- 9.11 Evidence of Financial Arrangements
- A. Upon request of Contractor, Owner shall furnish Contractor reasonable evidence that financial arrangements have been made to satisfy Owner's obligations under the Contract Documents (including obligations under proposed changes in the Work).
- 9.12 Safety Programs
- A. While at the Site, Owner's employees and representatives shall comply with the specific applicable requirements of Contractor's safety programs of which Owner has been informed.
 - B. Owner shall furnish copies of any applicable Owner safety programs to Contractor.

ARTICLE 10 – ENGINEER'S STATUS DURING CONSTRUCTION

10.01 Owner's Representative

- A. Engineer will be Owner's representative during the construction period. The duties and responsibilities and the limitations of authority of Engineer as Owner's representative during construction are set forth in the Contract.

10.02 Visits to Site

- A. Engineer will make visits to the Site at intervals appropriate to the various stages of construction as Engineer deems necessary in order to observe as an experienced and qualified design professional the progress that has been made and the quality of the various aspects of Contractor's executed Work. Based on information obtained during such visits and observations, Engineer, for the benefit of Owner, will determine, in general, if the Work is proceeding in accordance with the Contract Documents. Engineer will not be required to make exhaustive or continuous inspections on the Site to check the quality or quantity of the Work. Engineer's efforts will be directed toward providing for Owner a greater degree of confidence that the completed Work will conform generally to the Contract Documents. On the basis of such visits and observations, Engineer will keep Owner informed of the progress of the Work and will endeavor to guard Owner against defective Work.

- B. Engineer's visits and observations are subject to all the limitations on Engineer's authority and responsibility set forth in Paragraph 10.08. Particularly, but without limitation, during or as a result of Engineer's visits or observations of Contractor's Work, Engineer will not supervise, direct, control, or have authority over or be responsible for Contractor's means, methods, techniques, sequences, or procedures of construction, or the safety precautions and programs incident thereto, or for any failure of Contractor to comply with Laws and Regulations applicable to the performance of the Work.
- 10.03 Project Representative
- A. If Owner and Engineer have agreed that Engineer will furnish a Resident Project Representative to represent Engineer at the Site and assist Engineer in observing the progress and quality of the Work, then the authority and responsibilities of any such Resident Project Representative will be as provided in the Supplementary Conditions, and limitations on the responsibilities thereof will be as provided in Paragraph 10.08. If Owner designates another representative or agent to represent Owner at the Site who is not Engineer's consultant, agent, or employee, the responsibilities and authority and limitations thereon of such other individual or entity will be as provided in the Supplementary Conditions.
- 10.04 Rejecting Defective Work
- A. Engineer has the authority to reject Work in accordance with Article 14.
- 10.05 Shop Drawings, Change Orders and Payments
- A. Engineer's authority, and limitations thereof, as to Shop Drawings and Samples, are set forth in Paragraph 7.16.
- B. Engineer's authority, and limitations thereof, as to design calculations and design drawings submitted in response to a delegation of professional design services, if any, are set forth in Paragraph 7.19.
- C. Engineer's authority as to Change Orders is set forth in Article 11.
- D. Engineer's authority as to Applications for Payment is set forth in Article 15.
- 10.06 Determinations for Unit Price Work
- A. Engineer will determine the actual quantities and classifications of Unit Price Work performed by Contractor as set forth in Paragraph 13.03.
- 10.07 Decisions on Requirements of Contract Documents and Acceptability of Work
- A. Engineer will render decisions regarding the requirements of the Contract Documents, and judge the acceptability of the Work, pursuant to the specific procedures set forth herein for initial interpretations, Change Proposals, and acceptance of the Work. In rendering such decisions and judgments, Engineer will not show partiality to Owner or Contractor, and will not be liable to Owner, Contractor, or others in connection with any proceedings, interpretations, decisions, or judgments conducted or rendered in good faith.
- 10.08 Limitations on Engineer's Authority and Responsibilities
- A. Neither Engineer's authority or responsibility under this Article 10 or under any other provision of the Contract, nor any decision made by Engineer in good faith either to exercise or not exercise such authority or responsibility or the undertaking, exercise, or performance of any authority or responsibility by Engineer, shall create, impose, or give rise to any duty in contract, tort, or otherwise owed by Engineer to Contractor, any Subcontractor, any Supplier, any other individual or entity, or to any surety for or employee or agent of any of them.
- B. Engineer will not supervise, direct, control, or have authority over or be responsible for Contractor's means, methods, techniques, sequences, or procedures of construction, or the safety precautions and programs incident thereto, or for any failure of Contractor to comply with Laws and Regulations applicable to the performance of the Work. Engineer will not be responsible for Contractor's failure to perform the Work in accordance with the Contract Documents.

- C. Engineer will not be responsible for the acts or omissions of Contractor or of any Subcontractor, any Supplier, or of any other individual or entity performing any of the Work.
 - D. Engineer's review of the final Application for Payment and accompanying documentation and all maintenance and operating instructions, schedules, guarantees, bonds, certificates of inspection, tests and approvals, and other documentation required to be delivered by Paragraph 15.06.A will only be to determine generally that their content complies with the requirements of, and in the case of certificates of inspections, tests, and approvals, that the results certified indicate compliance with the Contract Documents.
 - E. The limitations upon authority and responsibility set forth in this Paragraph 10.08 shall also apply to the Resident Project Representative, if any.
- 10.09 Compliance with Safety Program
- A. While at the Site, Engineer's employees and representatives will comply with the specific applicable requirements of Owner's and Contractor's safety programs (if any) of which Engineer has been informed.

ARTICLE 11 – AMENDING THE CONTRACT DOCUMENTS; CHANGES IN THE WORK

11.01 Amending and Supplementing Contract Documents

- A. The Contract Documents may be amended or supplemented by a Change Order, a Work Change Directive, or a Field Order.
 - 1. Change Orders:
 - a. If an amendment or supplement to the Contract Documents includes a change in the Contract Price or the Contract Times, such amendment or supplement must be set forth in a Change Order. A Change Order also may be used to establish amendments and supplements of the Contract Documents that do not affect the Contract Price or Contract Times.
 - b. Owner and Contractor may amend those terms and conditions of the Contract Documents that do not involve (1) the performance or acceptability of the Work, (2) the design (as set forth in the Drawings, Specifications, or otherwise), or (3) other engineering or technical matters, without the recommendation of the Engineer. Such an amendment shall be set forth in a Change Order.
 - 2. Work Change Directives: A Work Change Directive will not change the Contract Price or the Contract Times but is evidence that the parties expect that the modification ordered or documented by a Work Change Directive will be incorporated in a subsequently issued Change Order, following negotiations by the parties as to the Work Change Directive's effect, if any, on the Contract Price and Contract Times; or, if negotiations are unsuccessful, by a determination under the terms of the Contract Documents governing adjustments, expressly including Paragraph 11.04 regarding change of Contract Price. Contractor must submit any Change Proposal seeking an adjustment of the Contract Price or the Contract Times, or both, no later than 30 days after the completion of the Work set out in the Work Change Directive. Owner must submit any Claim seeking an adjustment of the Contract Price or the Contract Times, or both, no later than 60 days after issuance of the Work Change Directive.
 - 3. Field Orders: Engineer may authorize minor changes in the Work if the changes do not involve an adjustment in the Contract Price or the Contract Times and are compatible with the design concept of the completed Project as a functioning whole as indicated by the Contract Documents. Such changes will be accomplished by a Field Order and will be binding on Owner and also on Contractor, which shall perform the Work involved promptly. If Contractor believes that a Field Order justifies an adjustment in the Contract Price or Contract Times, or

both, then before proceeding with the Work at issue, Contractor shall submit a Change Proposal as provided herein.

11.02 Owner-Authorized Changes in the Work

- A. Without invalidating the Contract and without notice to any surety, Owner may, at any time or from time to time, order additions, deletions, or revisions in the Work. Such changes shall be supported by Engineer's recommendation, to the extent the change involves the design (as set forth in the Drawings, Specifications, or otherwise), or other engineering or technical matters. Such changes may be accomplished by a Change Order, if Owner and Contractor have agreed as to the effect, if any, of the changes on Contract Times or Contract Price; or by a Work Change Directive. Upon receipt of any such document, Contractor shall promptly proceed with the Work involved; or, in the case of a deletion in the Work, promptly cease construction activities with respect to such deleted Work. Added or revised Work shall be performed under the applicable conditions of the Contract Documents. Nothing in this paragraph shall obligate Contractor to undertake work that Contractor reasonably concludes cannot be performed in a manner consistent with Contractor's safety obligations under the Contract Documents or Laws and Regulations.

11.03 Unauthorized Changes in the Work

- A. Contractor shall not be entitled to an increase in the Contract Price or an extension of the Contract Times with respect to any work performed that is not required by the Contract Documents, as amended, modified, or supplemented, except in the case of an emergency as provided in Paragraph 7.15 or in the case of uncovering Work as provided in Paragraph 14.05.

11.04 Change of Contract Price

- A. The Contract Price may only be changed by a Change Order. Any Change Proposal for an adjustment in the Contract Price shall comply with the provisions of Paragraph 11.06. Any Claim for an adjustment of Contract Price shall comply with the provisions of Article 12.
- B. An adjustment in the Contract Price will be determined as follows:
1. where the Work involved is covered by unit prices contained in the Contract Documents, then by application of such unit prices to the quantities of the items involved (subject to the provisions of Paragraph 13.03); or
 2. where the Work involved is not covered by unit prices contained in the Contract Documents, then by a mutually agreed lump sum (which may include an allowance for overhead and profit not necessarily in accordance with Paragraph 11.04.C.2); or
 3. where the Work involved is not covered by unit prices contained in the Contract Documents and the parties do not reach mutual agreement to a lump sum, then on the basis of the Cost of the Work (determined as provided in Paragraph 13.01) plus a Contractor's fee for overhead and profit (determined as provided in Paragraph 11.04.C).
- C. Contractor's Fee: When applicable, the Contractor's fee for overhead and profit shall be determined as follows:
1. a mutually acceptable fixed fee; or
 2. if a fixed fee is not agreed upon, then a fee based on the following percentages of the various portions of the Cost of the Work:
 - a. for costs incurred under Paragraphs 13.01.B.1 and 13.01.B.2, the Contractor's fee shall be 15 percent;
 - b. for costs incurred under Paragraph 13.01.B.3, the Contractor's fee shall be five percent;
 - c. where one or more tiers of subcontracts are on the basis of Cost of the Work plus a fee and no fixed fee is agreed upon, the intent of Paragraphs 11.04.C.2.a and 11.04.C.2.b is that the Contractor's fee shall be based on: (1) a fee of 15 percent of the costs incurred under Paragraphs 13.01.A.1 and 13.01.A.2 by the Subcontractor that actually performs the Work, at whatever tier, and (2) with respect to Contractor itself and to any

EJCDC® - Standard General Conditions of the Construction Contract.

Copyright © 2013 National Society of Professional Engineers, American Council of Engineering Companies, and American Society of Civil Engineers. All rights reserved.

Subcontractors of a tier higher than that of the Subcontractor that actually performs the Work, a fee of five percent of the amount (fee plus underlying costs incurred) attributable to the next lower tier Subcontractor; provided, however, that for any such subcontracted work the maximum total fee to be paid by Owner shall be no greater than 27 percent of the costs incurred by the Subcontractor that actually performs the work;

- d. no fee shall be payable on the basis of costs itemized under Paragraphs 13.01.B.4, 13.01.B.5, and 13.01.C;
- e. the amount of credit to be allowed by Contractor to Owner for any change which results in a net decrease in cost will be the amount of the actual net decrease in cost plus a deduction in Contractor's fee by an amount equal to five percent of such net decrease; and
- f. when both additions and credits are involved in any one change, the adjustment in Contractor's fee shall be computed on the basis of the net change in accordance with Paragraphs 11.04.C.2.a through 11.04.C.2.e, inclusive.

11.05 Change of Contract Times

- A. The Contract Times may only be changed by a Change Order. Any Change Proposal for an adjustment in the Contract Times shall comply with the provisions of Paragraph 11.06. Any Claim for an adjustment in the Contract Times shall comply with the provisions of Article 12.
- B. An adjustment of the Contract Times shall be subject to the limitations set forth in Paragraph 4.05, concerning delays in Contractor's progress.

11.06 Change Proposals

- A. Contractor shall submit a Change Proposal to Engineer to request an adjustment in the Contract Times or Contract Price; appeal an initial decision by Engineer concerning the requirements of the Contract Documents or relating to the acceptability of the Work under the Contract Documents; contest a set-off against payment due; or seek other relief under the Contract. The Change Proposal shall specify any proposed change in Contract Times or Contract Price, or both, or other proposed relief, and explain the reason for the proposed change, with citations to any governing or applicable provisions of the Contract Documents.
 1. Procedures: Contractor shall submit each Change Proposal to Engineer promptly (but in no event later than 30 days) after the start of the event giving rise thereto, or after such initial decision. The Contractor shall submit supporting data, including the proposed change in Contract Price or Contract Time (if any), to the Engineer and Owner within 15 days after the submittal of the Change Proposal. The supporting data shall be accompanied by a written statement that the supporting data are accurate and complete, and that any requested time or price adjustment is the entire adjustment to which Contractor believes it is entitled as a result of said event. Engineer will advise Owner regarding the Change Proposal, and consider any comments or response from Owner regarding the Change Proposal.
 2. Engineer's Action: Engineer will review each Change Proposal and, within 30 days after receipt of the Contractor's supporting data, either deny the Change Proposal in whole, approve it in whole, or deny it in part and approve it in part. Such actions shall be in writing, with a copy provided to Owner and Contractor. If Engineer does not take action on the Change Proposal within 30 days, then either Owner or Contractor may at any time thereafter submit a letter to the other party indicating that as a result of Engineer's inaction the Change Proposal is deemed denied, thereby commencing the time for appeal of the denial under Article 12.
 3. Binding Decision: Engineer's decision will be final and binding upon Owner and Contractor, unless Owner or Contractor appeals the decision by filing a Claim under Article 12.
- B. Resolution of Certain Change Proposals: If the Change Proposal does not involve the design (as set forth in the Drawings, Specifications, or otherwise), the acceptability of the Work, or other

engineering or technical matters, then Engineer will notify the parties that the Engineer is unable to resolve the Change Proposal. For purposes of further resolution of such a Change Proposal, such notice shall be deemed a denial, and Contractor may choose to seek resolution under the terms of Article 12.

11.07 Execution of Change Orders

- A. Owner and Contractor shall execute appropriate Change Orders covering:
1. changes in the Contract Price or Contract Times which are agreed to by the parties, including any undisputed sum or amount of time for Work actually performed in accordance with a Work Change Directive;
 2. changes in Contract Price resulting from an Owner set-off, unless Contractor has duly contested such set-off;
 3. changes in the Work which are: (a) ordered by Owner pursuant to Paragraph 11.02, (b) required because of Owner's acceptance of defective Work under Paragraph 14.04 or Owner's correction of defective Work under Paragraph 14.07, or (c) agreed to by the parties, subject to the need for Engineer's recommendation if the change in the Work involves the design (as set forth in the Drawings, Specifications, or otherwise), or other engineering or technical matters; and
 4. changes in the Contract Price or Contract Times, or other changes, which embody the substance of any final and binding results under Paragraph 11.06, or Article 12.
- B. If Owner or Contractor refuses to execute a Change Order that is required to be executed under the terms of this Paragraph 11.07, it shall be deemed to be of full force and effect, as if fully executed.

11.08 Notification to Surety

- A. If the provisions of any bond require notice to be given to a surety of any change affecting the general scope of the Work or the provisions of the Contract Documents (including, but not limited to, Contract Price or Contract Times), the giving of any such notice will be Contractor's responsibility. The amount of each applicable bond will be adjusted to reflect the effect of any such change.

ARTICLE 12 – CLAIMS

12.01 Claims

- A. Claims Process: The following disputes between Owner and Contractor shall be submitted to the Claims process set forth in this Article:
1. Appeals by Owner or Contractor of Engineer's decisions regarding Change Proposals;
 2. Owner demands for adjustments in the Contract Price or Contract Times, or other relief under the Contract Documents; and
 3. Disputes that Engineer has been unable to address because they do not involve the design (as set forth in the Drawings, Specifications, or otherwise), the acceptability of the Work, or other engineering or technical matters.
- B. Submittal of Claim: The party submitting a Claim shall deliver it directly to the other party to the Contract promptly (but in no event later than 30 days) after the start of the event giving rise thereto; in the case of appeals regarding Change Proposals within 30 days of the decision under appeal. The party submitting the Claim shall also furnish a copy to the Engineer, for its information only. The responsibility to substantiate a Claim shall rest with the party making the Claim. In the case of a Claim by Contractor seeking an increase in the Contract Times or Contract Price, or both, Contractor shall certify that the Claim is made in good faith, that the supporting data are accurate and complete, and that to the best of Contractor's knowledge and belief the amount of time or money requested accurately reflects the full amount to which Contractor is entitled.

EJCDC® - Standard General Conditions of the Construction Contract.

Copyright © 2013 National Society of Professional Engineers, American Council of Engineering Companies, and American Society of Civil Engineers. All rights reserved.

- C. Review and Resolution: The party receiving a Claim shall review it thoroughly, giving full consideration to its merits. The two parties shall seek to resolve the Claim through the exchange of information and direct negotiations. The parties may extend the time for resolving the Claim by mutual agreement. All actions taken on a Claim shall be stated in writing and submitted to the other party, with a copy to Engineer.
- D. Mediation:
 - 1. At any time after initiation of a Claim, Owner and Contractor may mutually agree to mediation of the underlying dispute. The agreement to mediate shall stay the Claim submittal and response process.
 - 2. If Owner and Contractor agree to mediation, then after 60 days from such agreement, either Owner or Contractor may unilaterally terminate the mediation process, and the Claim submittal and decision process shall resume as of the date of the termination. If the mediation proceeds but is unsuccessful in resolving the dispute, the Claim submittal and decision process shall resume as of the date of the conclusion of the mediation, as determined by the mediator.
 - 3. Owner and Contractor shall each pay one-half of the mediator's fees and costs.
- E. Partial Approval: If the party receiving a Claim approves the Claim in part and denies it in part, such action shall be final and binding unless within 30 days of such action the other party invokes the procedure set forth in Article 17 for final resolution of disputes.
- F. Denial of Claim: If efforts to resolve a Claim are not successful, the party receiving the Claim may deny it by giving written notice of denial to the other party. If the receiving party does not take action on the Claim within 90 days, then either Owner or Contractor may at any time thereafter submit a letter to the other party indicating that as a result of the inaction, the Claim is deemed denied, thereby commencing the time for appeal of the denial. A denial of the Claim shall be final and binding unless within 30 days of the denial the other party invokes the procedure set forth in Article 17 for the final resolution of disputes.
- G. Final and Binding Results: If the parties reach a mutual agreement regarding a Claim, whether through approval of the Claim, direct negotiations, mediation, or otherwise; or if a Claim is approved in part and denied in part, or denied in full, and such actions become final and binding; then the results of the agreement or action on the Claim shall be incorporated in a Change Order to the extent they affect the Contract, including the Work, the Contract Times, or the Contract Price.

ARTICLE 13 – COST OF THE WORK; ALLOWANCES; UNIT PRICE WORK

13.01 Cost of the Work

- A. Purposes for Determination of Cost of the Work: The term Cost of the Work means the sum of all costs necessary for the proper performance of the Work at issue, as further defined below. The provisions of this Paragraph 13.01 are used for two distinct purposes:
 - 1. To determine Cost of the Work when Cost of the Work is a component of the Contract Price, under cost-plus-fee, time-and-materials, or other cost-based terms; or
 - 2. To determine the value of a Change Order, Change Proposal, Claim, set-off, or other adjustment in Contract Price. When the value of any such adjustment is determined on the basis of Cost of the Work, Contractor is entitled only to those additional or incremental costs required because of the change in the Work or because of the event giving rise to the adjustment.
- B. Costs Included: Except as otherwise may be agreed to in writing by Owner, costs included in the Cost of the Work shall be in amounts no higher than those prevailing in the locality of the Project, shall not include any of the costs itemized in Paragraph 13.01.C, and shall include only the following items:

EJCDC® -, Standard General Conditions of the Construction Contract.
Copyright © 2013 National Society of Professional Engineers, American Council of Engineering Companies,
and American Society of Civil Engineers. All rights reserved.

1. Payroll costs for employees in the direct employ of Contractor in the performance of the Work under schedules of job classifications agreed upon by Owner and Contractor. Such employees shall include, without limitation, superintendents, foremen, and other personnel employed full time on the Work. Payroll costs for employees not employed full time on the Work shall be apportioned on the basis of their time spent on the Work. Payroll costs shall include, but not be limited to, salaries and wages plus the cost of fringe benefits, which shall include social security contributions, unemployment, excise, and payroll taxes, workers' compensation, health and retirement benefits, bonuses, sick leave, and vacation and holiday pay applicable thereto. The expenses of performing Work outside of regular working hours, on Saturday, Sunday, or legal holidays, shall be included in the above to the extent authorized by Owner.
2. Cost of all materials and equipment furnished and incorporated in the Work, including costs of transportation and storage thereof, and Suppliers' field services required in connection therewith. All cash discounts shall accrue to Contractor unless Owner deposits funds with Contractor with which to make payments, in which case the cash discounts shall accrue to Owner. All trade discounts, rebates, and refunds and returns from sale of surplus materials and equipment shall accrue to Owner, and Contractor shall make provisions so that they may be obtained.
3. Payments made by Contractor to Subcontractors for Work performed by Subcontractors. If required by Owner, Contractor shall obtain competitive bids from subcontractors acceptable to Owner and Contractor and shall deliver such bids to Owner, who will then determine, with the advice of Engineer, which bids, if any, will be acceptable. If any subcontract provides that the Subcontractor is to be paid on the basis of Cost of the Work plus a fee, the Subcontractor's Cost of the Work and fee shall be determined in the same manner as Contractor's Cost of the Work and fee as provided in this Paragraph 13.01.
4. Costs of special consultants (including but not limited to engineers, architects, testing laboratories, surveyors, attorneys, and accountants) employed for services specifically related to the Work.
5. Supplemental costs including the following:
 - a. The proportion of necessary transportation, travel, and subsistence expenses of Contractor's employees incurred in discharge of duties connected with the Work.
 - b. Cost, including transportation and maintenance, of all materials, supplies, equipment, machinery, appliances, office, and temporary facilities at the Site, and hand tools not owned by the workers, which are consumed in the performance of the Work, and cost, less market value, of such items used but not consumed which remain the property of Contractor.
 - c. Rentals of all construction equipment and machinery, and the parts thereof, whether rented from Contractor or others in accordance with rental agreements approved by Owner with the advice of Engineer, and the costs of transportation, loading, unloading, assembly, dismantling, and removal thereof. All such costs shall be in accordance with the terms of said rental agreements. The rental of any such equipment, machinery, or parts shall cease when the use thereof is no longer necessary for the Work.
 - d. Sales, consumer, use, and other similar taxes related to the Work, and for which Contractor is liable, as imposed by Laws and Regulations.
 - e. Deposits lost for causes other than negligence of Contractor, any Subcontractor, or anyone directly or indirectly employed by any of them or for whose acts any of them may be liable, and royalty payments and fees for permits and licenses.
 - f. Losses and damages (and related expenses) caused by damage to the Work, not compensated by insurance or otherwise, sustained by Contractor in connection with the

EJCDC® - Standard General Conditions of the Construction Contract.

Copyright © 2013 National Society of Professional Engineers, American Council of Engineering Companies, and American Society of Civil Engineers. All rights reserved.

performance of the Work (except losses and damages within the deductible amounts of property insurance established in accordance with Paragraph 6.05), provided such losses and damages have resulted from causes other than the negligence of Contractor, any Subcontractor, or anyone directly or indirectly employed by any of them or for whose acts any of them may be liable. Such losses shall include settlements made with the written consent and approval of Owner. No such losses, damages, and expenses shall be included in the Cost of the Work for the purpose of determining Contractor's fee.

- g. The cost of utilities, fuel, and sanitary facilities at the Site.
 - h. Minor expenses such as communication service at the Site, express and courier services, and similar petty cash items in connection with the Work.
 - i. The costs of premiums for all bonds and insurance that Contractor is required by the Contract Documents to purchase and maintain.
- C. Costs Excluded: The term Cost of the Work shall not include any of the following items:
- 1. Payroll costs and other compensation of Contractor's officers, executives, principals (of partnerships and sole proprietorships), general managers, safety managers, engineers, architects, estimators, attorneys, auditors, accountants, purchasing and contracting agents, expeditors, timekeepers, clerks, and other personnel employed by Contractor, whether at the Site or in Contractor's principal or branch office for general administration of the Work and not specifically included in the agreed upon schedule of job classifications referred to in Paragraph 13.01.B.1 or specifically covered by Paragraph 13.01.B.4. The payroll costs and other compensation excluded here are to be considered administrative costs covered by the Contractor's fee.
 - 2. Expenses of Contractor's principal and branch offices other than Contractor's office at the Site.
 - 3. Any part of Contractor's capital expenses, including interest on Contractor's capital employed for the Work and charges against Contractor for delinquent payments.
 - 4. Costs due to the negligence of Contractor, any Subcontractor, or anyone directly or indirectly employed by any of them or for whose acts any of them may be liable, including but not limited to, the correction of defective Work, disposal of materials or equipment wrongly supplied, and making good any damage to property.
 - 5. Other overhead or general expense costs of any kind and the costs of any item not specifically and expressly included in Paragraph 13.01.B.
- D. Contractor's Fee: When the Work as a whole is performed on the basis of cost-plus, Contractor's fee shall be determined as set forth in the Agreement. When the value of any Work covered by a Change Order, Change Proposal, Claim, set-off, or other adjustment in Contract Price is determined on the basis of Cost of the Work, Contractor's fee shall be determined as set forth in Paragraph 11.04.C.
- E. Documentation: Whenever the Cost of the Work for any purpose is to be determined pursuant to this Article 13, Contractor will establish and maintain records thereof in accordance with generally accepted accounting practices and submit in a form acceptable to Engineer an itemized cost breakdown together with supporting data.

13.02 Allowances

- A. It is understood that Contractor has included in the Contract Price all allowances so named in the Contract Documents and shall cause the Work so covered to be performed for such sums and by such persons or entities as may be acceptable to Owner and Engineer.
- B. Cash Allowances: Contractor agrees that:
 - 1. the cash allowances include the cost to Contractor (less any applicable trade discounts) of materials and equipment required by the allowances to be delivered at the Site, and all applicable taxes; and

2. Contractor's costs for unloading and handling on the Site, labor, installation, overhead, profit, and other expenses contemplated for the cash allowances have been included in the Contract Price and not in the allowances, and no demand for additional payment on account of any of the foregoing will be valid.
 - C. Contingency Allowance: Contractor agrees that a contingency allowance, if any, is for the sole use of Owner to cover unanticipated costs.
 - D. Prior to final payment, an appropriate Change Order will be issued as recommended by Engineer to reflect actual amounts due Contractor on account of Work covered by allowances, and the Contract Price shall be correspondingly adjusted.
- 13.03 Unit Price Work
- A. Where the Contract Documents provide that all or part of the Work is to be Unit Price Work, initially the Contract Price will be deemed to include for all Unit Price Work an amount equal to the sum of the unit price for each separately identified item of Unit Price Work times the estimated quantity of each item as indicated in the Agreement.
 - B. The estimated quantities of items of Unit Price Work are not guaranteed and are solely for the purpose of comparison of Bids and determining an Initial Contract Price. Payments to Contractor for Unit Price Work will be based on actual quantities.
 - C. Each unit price will be deemed to include an amount considered by Contractor to be adequate to cover Contractor's overhead and profit for each separately identified item.
 - D. Engineer will determine the actual quantities and classifications of Unit Price Work performed by Contractor. Engineer will review with Contractor the Engineer's preliminary determinations on such matters before rendering a written decision thereon (by recommendation of an Application for Payment or otherwise). Engineer's written decision thereon will be final and binding (except as modified by Engineer to reflect changed factual conditions or more accurate data) upon Owner and Contractor, subject to the provisions of the following paragraph.
 - E. Within 30 days of Engineer's written decision under the preceding paragraph, Contractor may submit a Change Proposal, or Owner may file a Claim, seeking an adjustment in the Contract Price if:
 1. the quantity of any item of Unit Price Work performed by Contractor differs materially and significantly from the estimated quantity of such item indicated in the Agreement;
 2. there is no corresponding adjustment with respect to any other item of Work; and
 3. Contractor believes that it is entitled to an increase in Contract Price as a result of having incurred additional expense or Owner believes that Owner is entitled to a decrease in Contract Price, and the parties are unable to agree as to the amount of any such increase or decrease.

ARTICLE 14 – TESTS AND INSPECTIONS; CORRECTION, REMOVAL OR ACCEPTANCE OF DEFECTIVE WORK

14.01 Access to Work

- A. Owner, Engineer, their consultants and other representatives and personnel of Owner, independent testing laboratories, and authorities having jurisdiction will have access to the Site and the Work at reasonable times for their observation, inspection, and testing. Contractor shall provide them proper and safe conditions for such access and advise them of Contractor's safety procedures and programs so that they may comply therewith as applicable.

14.02 Tests, Inspections, and Approvals

- A. Contractor shall give Engineer timely notice of readiness of the Work (or specific parts thereof) for all required inspections and tests, and shall cooperate with inspection and testing personnel to facilitate required inspections and tests.

- B. Owner shall retain and pay for the services of an independent inspector, testing laboratory, or other qualified individual or entity to perform all inspections and tests expressly required by the Contract Documents to be furnished and paid for by Owner, except that costs incurred in connection with tests or inspections of covered Work shall be governed by the provisions of Paragraph 14.05.
- C. If Laws or Regulations of any public body having jurisdiction require any Work (or part thereof) specifically to be inspected, tested, or approved by an employee or other representative of such public body, Contractor shall assume full responsibility for arranging and obtaining such inspections, tests, or approvals, pay all costs in connection therewith, and furnish Engineer the required certificates of inspection or approval.
- D. Contractor shall be responsible for arranging, obtaining, and paying for all inspections and tests required:
 - 1. by the Contract Documents, unless the Contract Documents expressly allocate responsibility for a specific inspection or test to Owner;
 - 2. to attain Owner's and Engineer's acceptance of materials or equipment to be incorporated in the Work;
 - 3. by manufacturers of equipment furnished under the Contract Documents;
 - 4. for testing, adjusting, and balancing of mechanical, electrical, and other equipment to be incorporated into the Work; and
 - 5. for acceptance of materials, mix designs, or equipment submitted for approval prior to Contractor's purchase thereof for incorporation in the Work.Such inspections and tests shall be performed by independent inspectors, testing laboratories, or other qualified individuals or entities acceptable to Owner and Engineer.
- E. If the Contract Documents require the Work (or part thereof) to be approved by Owner, Engineer, or another designated individual or entity, then Contractor shall assume full responsibility for arranging and obtaining such approvals.
- F. If any Work (or the work of others) that is to be inspected, tested, or approved is covered by Contractor without written concurrence of Engineer, Contractor shall, if requested by Engineer, uncover such Work for observation. Such uncovering shall be at Contractor's expense unless Contractor had given Engineer timely notice of Contractor's intention to cover the same and Engineer had not acted with reasonable promptness in response to such notice.

14.03 Defective Work

- A. Contractor's Obligation: It is Contractor's obligation to assure that the Work is not defective.
- B. Engineer's Authority: Engineer has the authority to determine whether Work is defective, and to reject defective Work.
- C. Notice of Defects: Prompt notice of all defective Work of which Owner or Engineer has actual knowledge will be given to Contractor.
- D. Correction, or Removal and Replacement: Promptly after receipt of written notice of defective Work, Contractor shall correct all such defective Work, whether or not fabricated, installed, or completed, or, if Engineer has rejected the defective Work, remove it from the Project and replace it with Work that is not defective.
- E. Preservation of Warranties: When correcting defective Work, Contractor shall take no action that would void or otherwise impair Owner's special warranty and guarantee, if any, on said Work.
- F. Costs and Damages: In addition to its correction, removal, and replacement obligations with respect to defective Work, Contractor shall pay all claims, costs, losses, and damages arising out of or relating to defective Work, including but not limited to the cost of the inspection, testing, correction, removal, replacement, or reconstruction of such defective Work, fines levied against Owner by governmental authorities because the Work is defective, and the costs of repair or

replacement of work of others resulting from defective Work. Prior to final payment, if Owner and Contractor are unable to agree as to the measure of such claims, costs, losses, and damages resulting from defective Work, then Owner may impose a reasonable set-off against payments due under Article 15.

14.04 Acceptance of Defective Work

- A. If, instead of requiring correction or removal and replacement of defective Work, Owner prefers to accept it, Owner may do so (subject, if such acceptance occurs prior to final payment, to Engineer's confirmation that such acceptance is in general accord with the design intent and applicable engineering principles, and will not endanger public safety). Contractor shall pay all claims, costs, losses, and damages attributable to Owner's evaluation of and determination to accept such defective Work (such costs to be approved by Engineer as to reasonableness), and for the diminished value of the Work to the extent not otherwise paid by Contractor. If any such acceptance occurs prior to final payment, the necessary revisions in the Contract Documents with respect to the Work shall be incorporated in a Change Order. If the parties are unable to agree as to the decrease in the Contract Price, reflecting the diminished value of Work so accepted, then Owner may impose a reasonable set-off against payments due under Article 15. If the acceptance of defective Work occurs after final payment, Contractor shall pay an appropriate amount to Owner.

14.05 Uncovering Work

- A. Engineer has the authority to require additional inspection or testing of the Work, whether or not the Work is fabricated, installed, or completed.
- B. If any Work is covered contrary to the written request of Engineer, then Contractor shall, if requested by Engineer, uncover such Work for Engineer's observation, and then replace the covering, all at Contractor's expense.
- C. If Engineer considers it necessary or advisable that covered Work be observed by Engineer or inspected or tested by others, then Contractor, at Engineer's request, shall uncover, expose, or otherwise make available for observation, inspection, or testing as Engineer may require, that portion of the Work in question, and provide all necessary labor, material, and equipment.
1. If it is found that the uncovered Work is defective, Contractor shall be responsible for all claims, costs, losses, and damages arising out of or relating to such uncovering, exposure, observation, inspection, and testing, and of satisfactory replacement or reconstruction (including but not limited to all costs of repair or replacement of work of others); and pending Contractor's full discharge of this responsibility the Owner shall be entitled to impose a reasonable set-off against payments due under Article 15.
 2. If the uncovered Work is not found to be defective, Contractor shall be allowed an increase in the Contract Price or an extension of the Contract Times, or both, directly attributable to such uncovering, exposure, observation, inspection, testing, replacement, and reconstruction. If the parties are unable to agree as to the amount or extent thereof, then Contractor may submit a Change Proposal within 30 days of the determination that the Work is not defective.

14.06 Owner May Stop the Work

- A. If the Work is defective, or Contractor fails to supply sufficient skilled workers or suitable materials or equipment, or fails to perform the Work in such a way that the completed Work will conform to the Contract Documents, then Owner may order Contractor to stop the Work, or any portion thereof, until the cause for such order has been eliminated; however, this right of Owner to stop the Work shall not give rise to any duty on the part of Owner to exercise this right for the benefit of Contractor, any Subcontractor, any Supplier, any other individual or entity, or any surety for, or employee or agent of any of them.

14.07 Owner May Correct Defective Work

- A. If Contractor fails within a reasonable time after written notice from Engineer to correct defective Work, or to remove and replace rejected Work as required by Engineer, or if Contractor fails to perform the Work in accordance with the Contract Documents, or if Contractor fails to comply with any other provision of the Contract Documents, then Owner may, after seven days written notice to Contractor, correct or remedy any such deficiency.
- B. In exercising the rights and remedies under this Paragraph 14.07, Owner shall proceed expeditiously. In connection with such corrective or remedial action, Owner may exclude Contractor from all or part of the Site, take possession of all or part of the Work and suspend Contractor's services related thereto, and incorporate in the Work all materials and equipment stored at the Site or for which Owner has paid Contractor but which are stored elsewhere. Contractor shall allow Owner, Owner's representatives, agents and employees, Owner's other contractors, and Engineer and Engineer's consultants access to the Site to enable Owner to exercise the rights and remedies under this paragraph.
- C. All claims, costs, losses, and damages incurred or sustained by Owner in exercising the rights and remedies under this Paragraph 14.07 will be charged against Contractor as set-offs against payments due under Article 15. Such claims, costs, losses and damages will include but not be limited to all costs of repair, or replacement of work of others destroyed or damaged by correction, removal, or replacement of Contractor's defective Work.
- D. Contractor shall not be allowed an extension of the Contract Times because of any delay in the performance of the Work attributable to the exercise by Owner of Owner's rights and remedies under this Paragraph 14.07.

ARTICLE 15 – PAYMENTS TO CONTRACTOR; SET-OFFS; COMPLETION; CORRECTION PERIOD**15.01 Progress Payments**

- A. Basis for Progress Payments: The Schedule of Values established as provided in Article 2 will serve as the basis for progress payments and will be incorporated into a form of Application for Payment acceptable to Engineer. Progress payments on account of Unit Price Work will be based on the number of units completed during the pay period, as determined under the provisions of Paragraph 13.03. Progress payments for cost-based Work will be based on Cost of the Work completed by Contractor during the pay period.
- B. Applications for Payments:
 1. At least 20 days before the date established in the Agreement for each progress payment (but not more often than once a month), Contractor shall submit to Engineer for review an Application for Payment filled out and signed by Contractor covering the Work completed as of the date of the Application and accompanied by such supporting documentation as is required by the Contract Documents. If payment is requested on the basis of materials and equipment not incorporated in the Work but delivered and suitably stored at the Site or at another location agreed to in writing, the Application for Payment shall also be accompanied by a bill of sale, invoice, or other documentation warranting that Owner has received the materials and equipment free and clear of all Liens, and evidence that the materials and equipment are covered by appropriate property insurance, a warehouse bond, or other arrangements to protect Owner's interest therein, all of which must be satisfactory to Owner.
 2. Beginning with the second Application for Payment, each Application shall include an affidavit of Contractor stating that all previous progress payments received on account of the Work have been applied on account to discharge Contractor's legitimate obligations associated with prior Applications for Payment.

3. The amount of retainage with respect to progress payments will be as stipulated in the Agreement.
- C. Review of Applications:
1. Engineer will, within 10 days after receipt of each Application for Payment, including each resubmittal, either indicate in writing a recommendation of payment and present the Application to Owner, or return the Application to Contractor indicating in writing Engineer's reasons for refusing to recommend payment. In the latter case, Contractor may make the necessary corrections and resubmit the Application.
 2. Engineer's recommendation of any payment requested in an Application for Payment will constitute a representation by Engineer to Owner, based on Engineer's observations of the executed Work as an experienced and qualified design professional, and on Engineer's review of the Application for Payment and the accompanying data and schedules, that to the best of Engineer's knowledge, information and belief:
 - a. the Work has progressed to the point indicated;
 - b. the quality of the Work is generally in accordance with the Contract Documents (subject to an evaluation of the Work as a functioning whole prior to or upon Substantial Completion, the results of any subsequent tests called for in the Contract Documents, a final determination of quantities and classifications for Unit Price Work under Paragraph 13.03, and any other qualifications stated in the recommendation); and
 - c. the conditions precedent to Contractor's being entitled to such payment appear to have been fulfilled in so far as it is Engineer's responsibility to observe the Work.
 3. By recommending any such payment Engineer will not thereby be deemed to have represented that:
 - a. inspections made to check the quality or the quantity of the Work as it has been performed have been exhaustive, extended to every aspect of the Work in progress, or involved detailed inspections of the Work beyond the responsibilities specifically assigned to Engineer in the Contract; or
 - b. there may not be other matters or issues between the parties that might entitle Contractor to be paid additionally by Owner or entitle Owner to withhold payment to Contractor.
 4. Neither Engineer's review of Contractor's Work for the purposes of recommending payments nor Engineer's recommendation of any payment, including final payment, will impose responsibility on Engineer:
 - a. to supervise, direct, or control the Work, or
 - b. for the means, methods, techniques, sequences, or procedures of construction, or the safety precautions and programs incident thereto, or
 - c. for Contractor's failure to comply with Laws and Regulations applicable to Contractor's performance of the Work, or
 - d. to make any examination to ascertain how or for what purposes Contractor has used the money paid on account of the Contract Price, or
 - e. to determine that title to any of the Work, materials, or equipment has passed to Owner free and clear of any Liens.
 5. Engineer may refuse to recommend the whole or any part of any payment if, in Engineer's opinion, it would be incorrect to make the representations to Owner stated in Paragraph 15.01.C.2.
 6. Engineer will recommend reductions in payment (set-offs) necessary in Engineer's opinion to protect Owner from loss because:
 - a. the Work is defective, requiring correction or replacement;

EJCDC® - Standard General Conditions of the Construction Contract.

Copyright © 2013 National Society of Professional Engineers, American Council of Engineering Companies,
and American Society of Civil Engineers. All rights reserved.

- b. the Contract Price has been reduced by Change Orders;
 - c. Owner has been required to correct defective Work in accordance with Paragraph 14.07, or has accepted defective Work pursuant to Paragraph 14.04;
 - d. Owner has been required to remove or remediate a Hazardous Environmental Condition for which Contractor is responsible; or
 - e. Engineer has actual knowledge of the occurrence of any of the events that would constitute a default by Contractor and therefore justify termination for cause under the Contract Documents.
- D. Payment Becomes Due:
- 1. Ten days after presentation of the Application for Payment to Owner with Engineer's recommendation, the amount recommended (subject to any Owner set-offs) will become due, and when due will be paid by Owner to Contractor.
- E. Reductions in Payment by Owner:
- 1. In addition to any reductions in payment (set-offs) recommended by Engineer, Owner is entitled to impose a set-off against payment based on any of the following:
 - a. claims have been made against Owner on account of Contractor's conduct in the performance or furnishing of the Work, or Owner has incurred costs, losses, or damages on account of Contractor's conduct in the performance or furnishing of the Work, including but not limited to claims, costs, losses, or damages from workplace injuries, adjacent property damage, non-compliance with Laws and Regulations, and patent infringement;
 - b. Contractor has failed to take reasonable and customary measures to avoid damage, delay, disruption, and interference with other work at or adjacent to the Site;
 - c. Contractor has failed to provide and maintain required bonds or insurance;
 - d. Owner has been required to remove or remediate a Hazardous Environmental Condition for which Contractor is responsible;
 - e. Owner has incurred extra charges or engineering costs related to submittal reviews, evaluations of proposed substitutes, tests and inspections, or return visits to manufacturing or assembly facilities;
 - f. the Work is defective, requiring correction or replacement;
 - g. Owner has been required to correct defective Work in accordance with Paragraph 14.07, or has accepted defective Work pursuant to Paragraph 14.04;
 - h. the Contract Price has been reduced by Change Orders;
 - i. an event that would constitute a default by Contractor and therefore justify a termination for cause has occurred;
 - j. liquidated damages have accrued as a result of Contractor's failure to achieve Milestones, Substantial Completion, or final completion of the Work;
 - k. Liens have been filed in connection with the Work, except where Contractor has delivered a specific bond satisfactory to Owner to secure the satisfaction and discharge of such Liens;
 - l. there are other items entitling Owner to a set off against the amount recommended.
 - 2. If Owner imposes any set-off against payment, whether based on its own knowledge or on the written recommendations of Engineer, Owner will give Contractor immediate written notice (with a copy to Engineer) stating the reasons for such action and the specific amount of the reduction, and promptly pay Contractor any amount remaining after deduction of the amount so withheld. Owner shall promptly pay Contractor the amount so withheld, or any adjustment thereto agreed to by Owner and Contractor, if Contractor remedies the reasons for such

action. The reduction imposed shall be binding on Contractor unless it duly submits a Change Proposal contesting the reduction.

3. Upon a subsequent determination that Owner's refusal of payment was not justified, the amount wrongfully withheld shall be treated as an amount due as determined by Paragraph 15.01.C.1 and subject to interest as provided in the Agreement.

15.02 Contractor's Warranty of Title

- A. Contractor warrants and guarantees that title to all Work, materials, and equipment furnished under the Contract will pass to Owner free and clear of (1) all Liens and other title defects, and (2) all patent, licensing, copyright, or royalty obligations, no later than seven days after the time of payment by Owner.

15.03 Substantial Completion

- A. When Contractor considers the entire Work ready for its intended use Contractor shall notify Owner and Engineer in writing that the entire Work is substantially complete and request that Engineer issue a certificate of Substantial Completion. Contractor shall at the same time submit to Owner and Engineer an initial draft of punch list items to be completed or corrected before final payment.
- B. Promptly after Contractor's notification, Owner, Contractor, and Engineer shall make an inspection of the Work to determine the status of completion. If Engineer does not consider the Work substantially complete, Engineer will notify Contractor in writing giving the reasons therefor.
- C. If Engineer considers the Work substantially complete, Engineer will deliver to Owner a preliminary certificate of Substantial Completion which shall fix the date of Substantial Completion. Engineer shall attach to the certificate a punch list of items to be completed or corrected before final payment. Owner shall have seven days after receipt of the preliminary certificate during which to make written objection to Engineer as to any provisions of the certificate or attached punch list. If, after considering the objections to the provisions of the preliminary certificate, Engineer concludes that the Work is not substantially complete, Engineer will, within 14 days after submission of the preliminary certificate to Owner, notify Contractor in writing that the Work is not substantially complete, stating the reasons therefor. If Owner does not object to the provisions of the certificate, or if despite consideration of Owner's objections Engineer concludes that the Work is substantially complete, then Engineer will, within said 14 days, execute and deliver to Owner and Contractor a final certificate of Substantial Completion (with a revised punch list of items to be completed or corrected) reflecting such changes from the preliminary certificate as Engineer believes justified after consideration of any objections from Owner.
- D. At the time of receipt of the preliminary certificate of Substantial Completion, Owner and Contractor will confer regarding Owner's use or occupancy of the Work following Substantial Completion, review the builder's risk insurance policy with respect to the end of the builder's risk coverage, and confirm the transition to coverage of the Work under a permanent property insurance policy held by Owner. Unless Owner and Contractor agree otherwise in writing, Owner shall bear responsibility for security, operation, protection of the Work, property insurance, maintenance, heat, and utilities upon Owner's use or occupancy of the Work.
- E. After Substantial Completion the Contractor shall promptly begin work on the punch list of items to be completed or corrected prior to final payment. In appropriate cases Contractor may submit monthly Applications for Payment for completed punch list items, following the progress payment procedures set forth above.
- F. Owner shall have the right to exclude Contractor from the Site after the date of Substantial Completion subject to allowing Contractor reasonable access to remove its property and complete or correct items on the punch list.

15.04 Partial Use or Occupancy

- A. Prior to Substantial Completion of all the Work, Owner may use or occupy any substantially completed part of the Work which has specifically been identified in the Contract Documents, or which Owner, Engineer, and Contractor agree constitutes a separately functioning and usable part of the Work that can be used by Owner for its intended purpose without significant interference with Contractor's performance of the remainder of the Work, subject to the following conditions:
1. At any time Owner may request in writing that Contractor permit Owner to use or occupy any such part of the Work that Owner believes to be substantially complete. If and when Contractor agrees that such part of the Work is substantially complete, Contractor, Owner, and Engineer will follow the procedures of Paragraph 15.03.A through E for that part of the Work.
 2. At any time Contractor may notify Owner and Engineer in writing that Contractor considers any such part of the Work substantially complete and request Engineer to issue a certificate of Substantial Completion for that part of the Work.
 3. Within a reasonable time after either such request, Owner, Contractor, and Engineer shall make an inspection of that part of the Work to determine its status of completion. If Engineer does not consider that part of the Work to be substantially complete, Engineer will notify Owner and Contractor in writing giving the reasons therefor. If Engineer considers that part of the Work to be substantially complete, the provisions of Paragraph 15.03 will apply with respect to certification of Substantial Completion of that part of the Work and the division of responsibility in respect thereof and access thereto.
 4. No use or occupancy or separate operation of part of the Work may occur prior to compliance with the requirements of Paragraph 6.05 regarding builder's risk or other property insurance.

15.05 Final Inspection

- A. Upon written notice from Contractor that the entire Work or an agreed portion thereof is complete, Engineer will promptly make a final inspection with Owner and Contractor and will notify Contractor in writing of all particulars in which this inspection reveals that the Work, or agreed portion thereof, is incomplete or defective. Contractor shall immediately take such measures as are necessary to complete such Work or remedy such deficiencies.

15.06 Final Payment

- A. Application for Payment:
1. After Contractor has, in the opinion of Engineer, satisfactorily completed all corrections identified during the final inspection and has delivered, in accordance with the Contract Documents, all maintenance and operating instructions, schedules, guarantees, bonds, certificates or other evidence of insurance, certificates of inspection, annotated record documents (as provided in Paragraph 7.1.1), and other documents, Contractor may make application for final payment.
 2. The final Application for Payment shall be accompanied (except as previously delivered) by:
 - a. all documentation called for in the Contract Documents;
 - b. consent of the surety, if any, to final payment;
 - c. satisfactory evidence that all title issues have been resolved such that title to all Work, materials, and equipment has passed to Owner free and clear of any Liens or other title defects, or will so pass upon final payment.
 - d. a list of all disputes that Contractor believes are unsettled; and
 - e. complete and legally effective releases or waivers (satisfactory to Owner) of all Lien rights arising out of the Work, and of Liens filed in connection with the Work.
 3. In lieu of the releases or waivers of Liens specified in Paragraph 15.06.A.2 and as approved by Owner, Contractor may furnish receipts or releases in full and an affidavit of Contractor that:

(a) the releases and receipts include all labor, services, material, and equipment for which a Lien could be filed; and (b) all payrolls, material and equipment bills, and other indebtedness connected with the Work for which Owner might in any way be responsible, or which might in any way result in liens or other burdens on Owner's property, have been paid or otherwise satisfied. If any Subcontractor or Supplier fails to furnish such a release or receipt in full, Contractor may furnish a bond or other collateral satisfactory to Owner to indemnify Owner against any Lien, or Owner at its option may issue joint checks payable to Contractor and specified Subcontractors and Suppliers.

B. Engineer's Review of Application and Acceptance:

1. If, on the basis of Engineer's observation of the Work during construction and final inspection, and Engineer's review of the final Application for Payment and accompanying documentation as required by the Contract Documents, Engineer is satisfied that the Work has been completed and Contractor's other obligations under the Contract have been fulfilled, Engineer will, within ten days after receipt of the final Application for Payment, indicate in writing Engineer's recommendation of final payment and present the Application for Payment to Owner for payment. Such recommendation shall account for any set-offs against payment that are necessary in Engineer's opinion to protect Owner from loss for the reasons stated above with respect to progress payments. At the same time Engineer will also give written notice to Owner and Contractor that the Work is acceptable, subject to the provisions of Paragraph 15.07. Otherwise, Engineer will return the Application for Payment to Contractor, indicating in writing the reasons for refusing to recommend final payment, in which case Contractor shall make the necessary corrections and resubmit the Application for Payment.

C. Completion of Work: The Work is complete (subject to surviving obligations) when it is ready for final payment as established by the Engineer's written recommendation of final payment.

D. Payment Becomes Due: Thirty days after the presentation to Owner of the final Application for Payment and accompanying documentation, the amount recommended by Engineer (less any further sum Owner is entitled to set off against Engineer's recommendation, including but not limited to set-offs for liquidated damages and set-offs allowed under the provisions above with respect to progress payments) will become due and shall be paid by Owner to Contractor.

15.07 Waiver of Claims

A. The making of final payment will not constitute a waiver by Owner of claims or rights against Contractor. Owner expressly reserves claims and rights arising from unsettled Liens, from defective Work appearing after final inspection pursuant to Paragraph 15.05, from Contractor's failure to comply with the Contract Documents or the terms of any special guarantees specified therein, from outstanding Claims by Owner, or from Contractor's continuing obligations under the Contract Documents.

B. The acceptance of final payment by Contractor will constitute a waiver by Contractor of all claims and rights against Owner other than those pending matters that have been duly submitted or appealed under the provisions of Article 17.

15.08 Correction Period

A. If within one year after the date of Substantial Completion (or such longer period of time as may be prescribed by the terms of any applicable special guarantee required by the Contract Documents, or by any specific provision of the Contract Documents), any Work is found to be defective, or if the repair of any damages to the Site, adjacent areas that Contractor has arranged to use through construction easements or otherwise, and other adjacent areas used by Contractor as permitted by Laws and Regulations, is found to be defective, then Contractor shall promptly, without cost to Owner and in accordance with Owner's written instructions:

1. correct the defective repairs to the Site or such other adjacent areas;

EJCDC® -, Standard General Conditions of the Construction Contract.

Copyright © 2013 National Society of Professional Engineers, American Council of Engineering Companies, and American Society of Civil Engineers. All rights reserved.

2. correct such defective Work;
 3. if the defective Work has been rejected by Owner, remove it from the Project and replace it with Work that is not defective, and
 4. satisfactorily correct or repair or remove and replace any damage to other Work, to the work of others, or to other land or areas resulting therefrom.
- B. If Contractor does not promptly comply with the terms of Owner's written instructions, or in an emergency where delay would cause serious risk of loss or damage, Owner may have the defective Work corrected or repaired or may have the rejected Work removed and replaced. Contractor shall pay all claims, costs, losses, and damages (including but not limited to all fees and charges of engineers, architects, attorneys, and other professionals and all court or arbitration or other dispute resolution costs) arising out of or relating to such correction or repair or such removal and replacement (including but not limited to all costs of repair or replacement of work of others).
- C. In special circumstances where a particular item of equipment is placed in continuous service before Substantial Completion of all the Work, the correction period for that item may start to run from an earlier date if so provided in the Specifications.
- D. Where defective Work (and damage to other Work resulting therefrom) has been corrected or removed and replaced under this paragraph, the correction period hereunder with respect to such Work will be extended for an additional period of one year after such correction or removal and replacement has been satisfactorily completed.
- E. Contractor's obligations under this paragraph are in addition to all other obligations and warranties. The provisions of this paragraph shall not be construed as a substitute for, or a waiver of, the provisions of any applicable statute of limitation or repose.

ARTICLE 16 – SUSPENSION OF WORK AND TERMINATION

16.01 Owner May Suspend Work

- A. At any time and without cause, Owner may suspend the Work or any portion thereof for a period of not more than 90 consecutive days by written notice to Contractor and Engineer. Such notice will fix the date on which Work will be resumed. Contractor shall resume the Work on the date so fixed. Contractor shall be entitled to an adjustment in the Contract Price or an extension of the Contract Times, or both, directly attributable to any such suspension. Any Change Proposal seeking such adjustments shall be submitted no later than 30 days after the date fixed for resumption of Work.

16.02 Owner May Terminate for Cause

- A. The occurrence of any one or more of the following events will constitute a default by Contractor and justify termination for cause:
1. Contractor's persistent failure to perform the Work in accordance with the Contract Documents (including, but not limited to, failure to supply sufficient skilled workers or suitable materials or equipment or failure to adhere to the Progress Schedule);
 2. Failure of Contractor to perform or otherwise to comply with a material term of the Contract Documents;
 3. Contractor's disregard of Laws or Regulations of any public body having jurisdiction; or
 4. Contractor's repeated disregard of the authority of Owner or Engineer.
- B. If one or more of the events identified in Paragraph 16.02.A occurs, then after giving Contractor (and any surety) ten days written notice that Owner is considering a declaration that Contractor is in default and termination of the contract, Owner may proceed to:
1. declare Contractor to be in default, and give Contractor (and any surety) notice that the Contract is terminated; and
 2. enforce the rights available to Owner under any applicable performance bond.

- C. Subject to the terms and operation of any applicable performance bond, if Owner has terminated the Contract for cause, Owner may exclude Contractor from the Site, take possession of the Work, incorporate in the Work all materials and equipment stored at the Site or for which Owner has paid Contractor but which are stored elsewhere, and complete the Work as Owner may deem expedient.
 - D. Owner may not proceed with termination of the Contract under Paragraph 16.02.B if Contractor within seven days of receipt of notice of intent to terminate begins to correct its failure to perform and proceeds diligently to cure such failure.
 - E. If Owner proceeds as provided in Paragraph 16.02.B, Contractor shall not be entitled to receive any further payment until the Work is completed. If the unpaid balance of the Contract Price exceeds the cost to complete the Work, including all related claims, costs, losses, and damages (including but not limited to all fees and charges of engineers, architects, attorneys, and other professionals) sustained by Owner, such excess will be paid to Contractor. If the cost to complete the Work including such related claims, costs, losses, and damages exceeds such unpaid balance, Contractor shall pay the difference to Owner. Such claims, costs, losses, and damages incurred by Owner will be reviewed by Engineer as to their reasonableness and, when so approved by Engineer, incorporated in a Change Order. When exercising any rights or remedies under this paragraph, Owner shall not be required to obtain the lowest price for the Work performed.
 - F. Where Contractor's services have been so terminated by Owner, the termination will not affect any rights or remedies of Owner against Contractor then existing or which may thereafter accrue, or any rights or remedies of Owner against Contractor or any surety under any payment bond or performance bond. Any retention or payment of money due Contractor by Owner will not release Contractor from liability.
 - G. If and to the extent that Contractor has provided a performance bond under the provisions of Paragraph 6.01.A, the provisions of that bond shall govern over any inconsistent provisions of Paragraphs 16.02.B and 16.02.D.
- 16.03 Owner May Terminate For Convenience
- A. Upon seven days written notice to Contractor and Engineer, Owner may, without cause and without prejudice to any other right or remedy of Owner, terminate the Contract. In such case, Contractor shall be paid for (without duplication of any items):
 - 1. completed and acceptable Work executed in accordance with the Contract Documents prior to the effective date of termination, including fair and reasonable sums for overhead and profit on such Work;
 - 2. expenses sustained prior to the effective date of termination in performing services and furnishing labor, materials, or equipment as required by the Contract Documents in connection with uncompleted Work, plus fair and reasonable sums for overhead and profit on such expenses; and
 - 3. other reasonable expenses directly attributable to termination, including costs incurred to prepare a termination for convenience cost proposal.
 - B. Contractor shall not be paid on account of loss of anticipated overhead, profits, or revenue, or other economic loss arising out of or resulting from such termination.
- 16.04 Contractor May Stop Work or Terminate
- A. If, through no act or fault of Contractor, (1) the Work is suspended for more than 90 consecutive days by Owner or under an order of court or other public authority, or (2) Engineer fails to act on any Application for Payment within 30 days after it is submitted, or (3) Owner fails for 30 days to pay Contractor any sum finally determined to be due, then Contractor may, upon seven days written notice to Owner and Engineer, and provided Owner or Engineer do not remedy such

suspension or failure within that time, terminate the contract and recover from Owner payment on the same terms as provided in Paragraph 16.03.

- B. In lieu of terminating the Contract and without prejudice to any other right or remedy, if Engineer has failed to act on an Application for Payment within 30 days after it is submitted, or Owner has failed for 30 days to pay Contractor any sum finally determined to be due, Contractor may, seven days after written notice to Owner and Engineer, stop the Work until payment is made of all such amounts due Contractor, including interest thereon. The provisions of this paragraph are not intended to preclude Contractor from submitting a Change Proposal for an adjustment in Contract Price or Contract Times or otherwise for expenses or damage directly attributable to Contractor's stopping the Work as permitted by this paragraph.

ARTICLE 17 – FINAL RESOLUTION OF DISPUTES

17.01 Methods and Procedures

- A. Disputes Subject to Final Resolution: The following disputed matters are subject to final resolution under the provisions of this Article:
1. A timely appeal of an approval in part and denial in part of a Claim, or of a denial in full; and
 2. Disputes between Owner and Contractor concerning the Work or obligations under the Contract Documents, and arising after final payment has been made.
- B. Final Resolution of Disputes: For any dispute subject to resolution under this Article, Owner or Contractor may:
1. elect in writing to invoke the dispute resolution process provided for in the Supplementary Conditions; or
 2. agree with the other party to submit the dispute to another dispute resolution process; or
 3. if no dispute resolution process is provided for in the Supplementary Conditions or mutually agreed to, give written notice to the other party of the intent to submit the dispute to a court of competent jurisdiction.

ARTICLE 18 – MISCELLANEOUS

18.01 Giving Notice

- A. Whenever any provision of the Contract Documents requires the giving of written notice, it will be deemed to have been validly given if:
1. delivered in person, by a commercial courier service or otherwise, to the individual or to a member of the firm or to an officer of the corporation for which it is intended; or
 2. delivered at or sent by registered or certified mail, postage prepaid, to the last business address known to the sender of the notice.

18.02 Computation of Times

- A. When any period of time is referred to in the Contract by days, it will be computed to exclude the first and include the last day of such period. If the last day of any such period falls on a Saturday or Sunday or on a day made a legal holiday by the law of the applicable jurisdiction, such day will be omitted from the computation.

18.03 Cumulative Remedies

- A. The duties and obligations imposed by these General Conditions and the rights and remedies available hereunder to the parties hereto are in addition to, and are not to be construed in any way as a limitation of, any rights and remedies available to any or all of them which are otherwise imposed or available by Laws or Regulations, by special warranty or guarantee, or by other provisions of the Contract. The provisions of this paragraph will be as effective as if repeated

- specifically in the Contract Documents in connection with each particular duty, obligation, right, and remedy to which they apply.
- 18.04 Limitation of Damages
- A. With respect to any and all Change Proposals, Claims, disputes subject to final resolution, and other matters at issue, neither Owner nor Engineer, nor any of their officers, directors, members, partners, employees, agents, consultants, or subcontractors, shall be liable to Contractor for any claims, costs, losses, or damages sustained by Contractor on or in connection with any other project or anticipated project.
- 18.05 No Waiver
- A. A party's non-enforcement of any provision shall not constitute a waiver of that provision, nor shall it affect the enforceability of that provision or of the remainder of this Contract.
- 18.06 Survival of Obligations
- A. All representations, indemnifications, warranties, and guarantees made in, required by, or given in accordance with the Contract, as well as all continuing obligations indicated in the Contract, will survive final payment, completion, and acceptance of the Work or termination or completion of the Contract or termination of the services of Contractor.
- 18.07 Controlling Law
- A. This Contract is to be governed by the law of the state in which the Project is located.
- 18.08 Headings
- A. Article and paragraph headings are inserted for convenience only and do not constitute parts of these General Conditions.

END OF DOCUMENT 00700 – GENERAL CONDITIONS

DOCUMENT 00800 – SUPPLEMENTARY CONDITIONS**GENERAL**

These Supplementary Conditions amend or supplement the Standard General Conditions of the Construction Contract, EJCDC® C-700 (2013 Edition). All provisions that are not so amended or supplemented remain in full force and effect.

The terms used in these Supplementary Conditions have the meanings stated in the General Conditions. Additional terms used in these Supplementary Conditions have the meanings stated below, which are applicable to both the singular and plural thereof.

ARTICLE 2 – PRELIMINARY MATTERS**2.02 Copies of Documents**

Delete Paragraph 2.02.A in its entirety and insert the following in its place.

- A. Owner shall furnish to Contractor one printed copy of the Contract including one fully executed counterpart of the Agreement. An electronic portable document format (PDF) may be requested by Contractor.

2.03 Before Starting Construction

Delete Paragraph 2.03 in its entirety.

2.04 Preconstruction Conference; Designation of Authorized Representatives

Delete Paragraph 2.04.A in its entirety and insert the following in its place:

- A. Before any Work at the Site is started, a conference attended by Owner, Contractor, Engineer, and others as appropriate will be held to establish a working understanding among the parties as to the Work and to discuss the schedules, procedures for handling Shop Drawings, Samples, and other submittals, processing Applications for Payment, electronic or digital transmittals, and maintaining required records.

2.05 Initial Acceptance of Schedules

Delete Paragraph 2.05 in its entirety.

ARTICLE 3 – DOCUMENTS: INTENT, REQUIREMENTS, REUSE**3.04 Requirements of the Contract Documents**

Delete Paragraph 3.04.C in its entirety and insert the following:

- C. If a submitted matter in question concerns terms and conditions of the Contract Documents that do not involve (1) the performance or acceptability of the Work under the Contract Documents, (2) the design (as set forth in the Drawings, Specifications, or otherwise), or (3) other engineering or technical matters, then Engineer will promptly give written notice to Owner and Contractor that Engineer is unable to provide a decision or interpretation. If Owner and Contractor are unable to agree on resolution of such a matter in question, either party may pursue resolution as provided FDOT Section 5-12 Claims by Contractor.

ARTICLE 4 – COMMENCEMENT AND PROGRESS OF THE WORK**4.01 Commencement of Contract Times; Notice to Proceed**

Delete Paragraph 4.01.A in its entirety and insert the following in its place.

- A. The Contract Times will commence to run on the thirtieth day after the Effective Date of the Contract or, if a Notice to Proceed is given, on the day indicated in the Notice to Proceed. A Notice to Proceed may be given at any time within 30 days after the Effective Date of the Contract. In no event will the Contract Times commence to run later than the one hundred twenty-fifth (125th) day after the day of Bid opening or the thirtieth day after the Effective Date of the Contract, whichever date is earlier.

ARTICLE 5 – AVAILABILITY OF LANDS; SUBSURFACE AND PHYSICAL CONDITIONS; HAZARDOUS ENVIRONMENTAL CONDITIONS**5.02 Use of Site and Other Areas**

Delete Paragraph 5.02.A.2 in its entirety and insert the following:

2. If a damage or injury claim is made by the owner or occupant of any such land or area because of the performance of the Work, or because of other actions or conduct of the Contractor or those for which Contractor is responsible, Contractor shall (a) take immediate corrective or remedial action as required by Paragraph 7.12, or otherwise; (b) promptly attempt to settle the claim as to all parties through negotiations with such owner or occupant, or otherwise resolve the claim by mediation, or at law; and (c) indemnify and hold harmless Owner and Engineer, and the officers, directors, members, partners, employees, agents, consultants and subcontractors of each and any of them from and against any such claim, and against all costs, losses, and damages (including but not limited to all fees and charges of engineers, architects, attorneys, and other professionals and all court or mediation costs) arising out of or relating to any claim or action, legal or equitable, brought by any such owner or occupant against Owner, Engineer, or any other party indemnified hereunder to the extent caused directly or indirectly, in whole or in part by, or based upon, Contractor's performance of the Work, or because of other actions or conduct of the Contractor or those for which Contractor is responsible.

5.03 Subsurface and Physical Conditions

Delete Paragraphs 5.03.A and 5.03.B in their entirety and insert the following:

- A. No reports of explorations or tests of subsurface conditions at or adjacent to the Site, or drawings of physical conditions relating to existing surface or subsurface structures at the Site, are known to Owner.

5.06 Hazardous Environmental Conditions

Delete Paragraphs 5.06.B and 5.06.I in their entirety.

Delete Paragraphs 5.06.A and 5.06.J in their entirety and insert the following:

- A. No reports or drawings related to Hazardous Environmental Conditions at the Site are known to Owner.
- J. Contractor shall indemnify and hold harmless Owner and Engineer, and the officers, directors, members, partners, employees, agents, consultants, and subcontractors of each and any of them from and against all claims, costs, losses, and damages (including but not limited to all fees and charges of engineers, architects, attorneys, and other professionals and all court or mediation or other dispute resolution costs) arising out of or relating to the failure to control, contain, or remove a Constituent of Concern brought to the Site by Contractor or by anyone for whom Contractor is responsible, or to a Hazardous Environmental Condition created by Contractor or by anyone for whom Contractor is responsible. Nothing in this Paragraph 5.06.J shall obligate Contractor to

indemnify any individual or entity from and against the consequences of that individual's or entity's own negligence.

ARTICLE 6 – BONDS AND INSURANCE

6.01 Performance, Payment and Other Bonds

Add the following paragraph immediately after Paragraph 6.01.C:

1. All bonds shall be written by a surety with no less than an "A" rating by national rating agency. All sureties must be on the U.S. Department of Treasury's Listing of Approved Sureties (Department Circular 570) and bonds must be within the Treasury's underwriting limitation.

6.02 Insurance – General Requirements

Delete Paragraph 6.02.B in its entirety and insert the following:

- B. All insurance required by the Contract to be purchased and maintained by OWNER and CONTRACTOR shall be obtained from insurance companies that are duly licensed or authorized, in the state or jurisdiction in which the Project is located, to issue insurance policies for the required limits and coverages. All companies that provide insurance policies required under this CONTRACT shall have a minimum A+, Class X or higher in the Bests Key Rating Guide.

Add the following new paragraph immediately after Paragraph 6.02.J:

- K. Where applicable, Okaloosa County Board of County Commissioners shall be shown as an Additional Insured with a waiver of subrogation on the certificate of insurance.

6.03 Contractor’s Insurance

Add the following new paragraph immediately after Paragraph 6.03.J:

K. The limits of liability for the insurance required by Paragraph 6.03 of the General Conditions shall provide coverage for not less than the following amounts or greater where required by Laws and Regulations:

1. Workers’ Compensation, and related coverages under Paragraphs 6.03.A.1 and A.2 of the General Conditions:

State:	<u>Statutory</u>
Federal, if applicable (e.g., Longshoreman’s):	<u>Statutory</u>
Employer’s Liability:	
Bodily injury, each accident	\$ <u>500,000</u>
Bodily injury by disease, each employee	\$ <u>500,000</u>
Bodily injury/disease aggregate	\$ <u>500,000</u>

2. Contractor’s Commercial General Liability under Paragraphs 6.03.B and 6.03.C of the General Conditions:

General Aggregate	\$ <u>1,000,000</u>
Products - Completed Operations Aggregate	\$ <u>1,000,000</u>
Personal and Advertising Injury	\$ <u>1,000,000</u>
Each Occurrence (Bodily Injury and Property Damage)	\$ <u>1,000,000</u>

3. Automobile Liability under Paragraph 6.03.D. of the General Conditions:

Bodily Injury:	
Each person	\$ <u>1,000,000</u>
Each accident	\$ <u>1,000,000</u>
Property Damage:	
Each accident	\$ <u>500,000</u>
<i>[or]</i>	
Combined Single Limit of	\$ <u>1,000,000</u>

Additional Insureds: In addition to Owner (Okaloosa County Board of County Commissioners) include as additional insureds the following: FDOT; City of Shalimar, FL; Taylor Engineering Inc., 4300 Legendary Drive, Suite C246, Destin FL. 32541.

4. Contractor’s Pollution under Paragraph 6.03.F of the General Conditions

Each Occurrence	\$ <u>Not Required</u>
General Aggregate	\$ <u>Not Required</u>

5. Contractor’s Professional Liability under Paragraph 6.03.H of the General Conditions

Each Occurrence	\$ <u>Not Required</u>
Annual Aggregate	\$ <u>Not Required</u>

Delete Paragraph 6.03.C.1 in its entirety and insert the following in its place:

1. Products and completed operations coverage:
 - a. Such insurance shall be maintained for two years after final payment.
 - b. Contractor shall furnish Owner and each other additional insured (as identified in the Supplementary Conditions or elsewhere in the Contract) evidence continuation of such insurance at final payment and two years thereafter.

ARTICLE 7 – CONTRACTOR’S RESPONSIBILITIES

7.02 Labor; Working Hours

Delete Paragraph 7.02 B. in its entirety and insert the following:

- B. In the absence of any Laws or Regulations to the contrary, Contractor may perform the Work on holidays, during any or all hours of the day, and on any or all days of the week, at Contractor's sole discretion.

7.07 Patent Fees and Royalties

Delete Paragraphs 7.07.B and C in their entirety and replace with the following:

- C. Contractor shall indemnify and hold harmless Owner and Engineer, and the officers, directors, members, partners, employees, agents, consultants and subcontractors of each and any of them from and against all claims, costs, losses, and damages (including but not limited to all fees and charges of engineers, architects, attorneys, and other professionals and all court or mediation or other dispute resolution costs) arising out of or relating to any infringement of patent rights or copyrights incident to the use in the performance of the Work or resulting from the incorporation in the Work of any invention, design, process, product, or device not specified in the Contract Documents.

7.10 Laws and Regulations

Delete Paragraph 7.10.B in its entirety and replace with the following:

- B. If Contractor performs any Work or takes any other action knowing or having reason to know that it is contrary to Laws or Regulations, Contractor shall bear all resulting costs and losses, and shall indemnify and hold harmless Owner and Engineer, and the officers, directors, members, partners, employees, agents, consultants, and subcontractors of each and any of them from and against all claims, costs, losses, and damages (including but not limited to all fees and charges of engineers, architects, attorneys, and other professionals and all court or mediation or other dispute resolution costs) arising out of or relating to such Work or other action. It shall not be Contractor's responsibility to make certain that the Work described in the Contract Documents is in accordance with Laws and Regulations, but this shall not relieve Contractor of Contractor's obligations under Paragraph 3.03.

7.18 Indemnification

Delete Paragraph 7.18.A in its entirety and insert the following:

- A. Contractor shall indemnify and hold harmless the Owner and the design Engineer, and the officers, directors, members, partners, employees, agents, consultants and subcontractors of each and any of them from and against all claims, costs, losses, and damages (including but not limited to all fees and charges of engineers, architects, attorneys, and other professionals and all court or mediation or other dispute resolution costs) arising out of or relating to the performance of the Work, provided that any such claim, cost, loss, or damage is attributable to bodily injury, sickness, disease, or death, or to injury to or destruction of tangible property (other than the Work itself), including the loss of use resulting therefrom but only to the extent caused by any negligent act or omission of Contractor, any Subcontractor, any Supplier, or any individual or entity directly or indirectly employed by any of them to perform any of the Work or anyone for whose acts any of them may be liable.

ARTICLE 8 – OTHER WORK AT THE SITE**8.03 Legal Relationships**

Delete Paragraph 8.03.D in its entirety and insert the following:

- D. If Contractor damages, delays, disrupts, or interferes with the work of any other contractor, or any utility owner performing other work at or adjacent to the Site, through Contractor's failure to take reasonable and customary measures to avoid such impacts, or if any claim arising out of Contractor's actions, inactions, or negligence in performance of the Work at or adjacent to the Site is made by any such other contractor or utility owner against Contractor, Owner, or Engineer (both Design and CEI), then Contractor shall (1) promptly attempt to settle the claim as to all parties through negotiations with such other contractor or utility owner, or otherwise resolve the claim by mediation or other dispute resolution proceeding or at law, and (2) indemnify and hold harmless Owner and Engineer, and the officers, directors, members, partners, employees, agents, consultants and subcontractors of each and any of them from and against any such claims, and against all costs, losses, and damages (including but not limited to all fees and charges of engineers, architects, attorneys, and other professionals and all court or mediation or other dispute resolution costs) arising out of or relating to such damage, delay, disruption, or interference.

ARTICLE 10 – ENGINEER'S STATUS DURING CONSTRUCTION**10.03 Project Representative**

Add the following new paragraphs immediately after Paragraph 10.03.A:

- B. The Resident Project Representative (RPR) will be Engineer's representative at the Site, will act as directed by and under the supervision of Engineer, and will confer with Engineer regarding RPR's actions.
 1. General: RPR's dealings in matters pertaining to the Work in general shall be with Engineer and Contractor. RPR's dealings with Subcontractors shall only be through or with the full knowledge and approval of Contractor. RPR shall generally communicate with Owner only with the knowledge of and under the direction of Engineer.
 2. Schedules: Review the progress schedule, schedule of Shop Drawing and Sample submittals, and Schedule of Values prepared by Contractor and consult with Engineer concerning acceptability.
 3. Conferences and Meetings: Attend meetings with Contractor, such as preconstruction conferences, progress meetings, job conferences, and other Project-related meetings, and prepare and circulate copies of minutes thereof.
 4. Liaison:
 - a. Serve as Engineer's liaison with Contractor. Working principally through Contractor's authorized representative or designee, assist in providing information regarding the provisions and intent of the Contract Documents.
 - b. Assist Engineer in serving as Owner's liaison with Contractor when Contractor's operations affect Owner's on-Site operations.
 - c. Assist in obtaining from Owner additional details or information, when required for proper execution of the Work.
 5. Interpretation of Contract Documents: Report to Engineer when clarifications and interpretations of the Contract Documents are needed and transmit to Contractor clarifications and interpretations as issued by Engineer.
 6. Shop Drawings and Samples:
 - a. Record date of receipt of Samples and Contractor-approved Shop Drawings.
 - b. Receive Samples which are furnished at the Site by Contractor, and notify Engineer of availability of Samples for examination.

- c. Advise Engineer and Contractor of the commencement of any portion of the Work requiring a Shop Drawing or Sample submittal for which RPR believes that the submittal has not been approved by Engineer.
7. Modifications: Consider and evaluate Contractor's suggestions for modifications in Drawings or Specifications and report such suggestions, together with RPR's recommendations, if any, to Engineer. Transmit to Contractor in writing decisions as issued by Engineer.
8. Review of Work and Rejection of Defective Work:
 - a. Conduct on-Site observations of Contractor's work in progress to assist Engineer in determining if the Work is in general proceeding in accordance with the Contract Documents.
 - b. Report to Engineer whenever RPR believes that any part of Contractor's work in progress is defective, will not produce a completed Project that conforms generally to the Contract Documents, or will imperil the integrity of the design concept of the completed Project as a functioning whole as indicated in the Contract Documents, or has been damaged, or does not meet the requirements of any inspection, test or approval required to be made; and advise Engineer of that part of work in progress that RPR believes should be corrected or rejected or should be uncovered for observation, or requires special testing, inspection or approval.
9. Inspections, Tests, and System Start-ups:
 - a. Verify that tests, equipment, and systems start-ups and operating and maintenance training are conducted in the presence of appropriate Owner's personnel, and that Contractor maintains adequate records thereof.
 - b. Observe, record, and report to Engineer appropriate details relative to the test procedures and systems start-ups.
10. Records:
 - a. Prepare a daily report or keep a diary or log book, recording Contractor's hours on the Site, Subcontractors present at the Site, weather conditions, data relative to questions of Change Orders, Field Orders, Work Change Directives, or changed conditions, Site visitors, deliveries of equipment or materials, daily activities, decisions, observations in general, and specific observations in more detail as in the case of observing test procedures; and send copies to Engineer.
 - b. Record names, addresses, fax numbers, e-mail addresses, web site locations, and telephone numbers of all Contractors, Subcontractors, and major Suppliers of materials and equipment.
 - c. Maintain records for use in preparing Project documentation.
11. Reports:
 - a. Furnish to Engineer periodic reports as required of progress of the Work and of Contractor's compliance with the Progress Schedule and schedule of Shop Drawing and Sample submittals.
 - b. Draft and recommend to Engineer proposed Change Orders, Work Change Directives, and Field Orders. Obtain backup material from Contractor.
 - c. Immediately notify Engineer of the occurrence of any Site accidents, emergencies, acts of God endangering the Work, force majeure or delay events, damage to property by fire or other causes, or the discovery of any Constituent of Concern or Hazardous Environmental Condition.
12. Payment Requests: Review applications for payment with Contractor for compliance with the established procedure for their submission and forward with recommendations to Engineer, noting particularly the relationship of the payment requested to the Schedule of Values, Work completed, and materials and equipment delivered at the Site but not incorporated in the Work.

13. Certificates, Operation and Maintenance Manuals: During the course of the Work, verify that materials and equipment certificates, operation and maintenance manuals and other data required by the Contract Documents to be assembled and furnished by Contractor are applicable to the items actually installed and in accordance with the Contract Documents, and have these documents delivered to Engineer for review and forwarding to Owner prior to payment for that part of the Work.
 14. Completion:
 - a. Participate in Engineer's visits to the Site to determine Substantial Completion, assist in the determination of Substantial Completion and the preparation of a punch list of items to be completed or corrected.
 - b. Participate in Engineer's final visit to the Site to determine completion of the Work, in the company of Owner and Contractor, and prepare a final punch list of items to be completed and deficiencies to be remedied.
 - c. Observe whether all items on the final list have been completed or corrected and make recommendations to Engineer concerning acceptance and issuance of the notice of acceptability of the work.
- C. The RPR shall not:
1. Authorize any deviation from the Contract Documents or substitution of materials or equipment (including "or-equal" items).
 2. Exceed limitations of Engineer's authority as set forth in the Contract Documents.
 3. Undertake any of the responsibilities of Contractor, Subcontractors, or Suppliers.
 4. Advise on, issue directions relative to, or assume control over any aspect of the means, methods, techniques, sequences or procedures of Contractor's work.
 5. Advise on, issue directions regarding, or assume control over security or safety practices, precautions, and programs in connection with the activities or operations of Owner or Contractor.
 6. Participate in specialized field or laboratory tests or inspections conducted off-site by others except as specifically authorized by Engineer.
 7. Accept Shop Drawing or Sample submittals from anyone other than Contractor.
 8. Authorize Owner to occupy the Project in whole or in part.

ARTICLE 13 – COST OF THE WORK; ALLOWANCES; UNIT PRICE WORK

13.03 Unit Price Work

Delete Paragraph 13.03.E in its entirety and insert the following in its place:

- E. The unit price of an item of Unit Price Work shall be subject to reevaluation and adjustment under the following conditions:
1. if the extended price of a particular item of Unit Price Work amounts to 5 percent or more of the Contract Price (based on estimated quantities at the time of Contract formation) and the variation in the quantity of that particular item of Unit Price Work actually furnished or performed by Contractor differs by more than 25 percent from the estimated quantity of such item indicated in the Agreement; and
 2. if there is no corresponding adjustment with respect to any other item of Work; and
 3. if Contractor believes that Contractor has incurred additional expense as a result thereof, Contractor may submit a Change Proposal, or if Owner believes that the quantity variation entitles Owner to an adjustment in the unit price, Owner may make a Claim, seeking an adjustment in the Contract Price.

ARTICLE 15 – PAYMENTS TO CONTRACTOR; SET-OFFS; COMPLETION; CORRECTION PERIOD

15.01 Progress Payments

Delete Paragraph 15.01.B.1 in its entirety and insert the following in its place:

B. Applications for Payment

1. Application for payment shall generally be submitted on a monthly basis (no more than once per month), Contractor shall submit to Engineer for review an Application for Payment filled out and signed by Contractor covering the Work completed as of the date of the Application and accompanied by such supporting documentation as is required by the Contract Documents. If payment is requested on the basis of materials and equipment not incorporated in the Work but delivered and suitably stored at the Site or at another location agreed to in writing, the Application for Payment shall also be accompanied by a bill of sale, invoice, or other documentation warranting that Owner has received the materials and equipment free and clear of all Liens, and evidence that the materials and equipment are covered by appropriate property insurance, a warehouse bond, or other arrangements to protect Owner's interest therein, all of which must be satisfactory to Owner.

Delete Paragraph 15.01.C.1 in its entirety and insert the following in its place:

C. Review of Application

1. Engineer will within 5 business days after receipt of each Application for Payment, including each resubmittal, either indicate in writing a recommendation of payment and present the Application to Owner, or return the Application to Contractor indicating in writing Engineer's reasons for refusing to recommend payment. In the latter case, Contractor may make the necessary corrections and resubmit the Application.

15.03 Substantial Completion

Add the following new subparagraph to Paragraph 15.03.B:

1. If some or all of the Work has been determined not to be at a point of Substantial Completion and will require re-inspection or re-testing by Engineer, the cost of such re-inspection or re-testing, including the cost of time, travel and living expenses, shall be paid by Contractor to Owner. If Contractor does not pay, or the parties are unable to agree as to the amount owed, then Owner may impose a reasonable set-off against payments due under Article 15.

15.08 Correction Period

Delete Paragraph 15.08.B in its entirety and insert the following in its place:

- B. If Contractor does not promptly comply with the terms of Owner's written instructions, or in an emergency where delay would cause serious risk of loss or damage, Owner may have the defective Work corrected or repaired or may have the rejected Work removed and replaced. Contractor shall pay all claims, costs, losses, and damages (including but not limited to all fees and charges of engineers, architects, attorneys, and other professionals and all court or mediation or other dispute resolution costs) arising out of or relating to such correction or repair or such removal and replacement (including but not limited to all costs of repair or replacement of work of others)

ARTICLE 16 – SUSPENSION OF WORK AND TERMINATION

16.04 Contractor May Stop Work or Terminate

Delete Paragraphs 16.04.A and 16.04.B in their entirety and insert the following in their place:

- A. If, through no act or fault of Contractor, (1) the Work is suspended for more than 90 consecutive days by Owner or under an order of court or other public authority, or (2) Engineer fails to act on any Application for Payment within 30 days after it is submitted, or (3) Owner fails for 60 days to pay Contractor any sum finally determined to be due, then Contractor may, upon seven days written notice to Owner and Engineer, and provided Owner or Engineer do not remedy such suspension or failure within that time, terminate the contract and recover from Owner payment on the same terms as provided in Paragraph 16.03.
- B. In lieu of terminating the Contract and without prejudice to any other right or remedy, if Engineer has failed to act on an Application for Payment within 30 days after it is submitted, or Owner has failed for 60 days to pay Contractor any sum finally determined to be due, Contractor may, seven

days after written notice to Owner and Engineer, stop the Work until payment is made of all such amounts due Contractor, including interest thereon. The provisions of this paragraph are not intended to preclude Contractor from submitting a Change Proposal for an adjustment in Contract Price or Contract Times or otherwise for expenses or damage directly attributable to Contractor's stopping the Work as permitted by this paragraph.

ARTICLE 18 – MISCELLANEOUS

18.07 Controlling Law

Delete paragraph 18.07.A in its entirety and replace the following in its place:

- A. This Contract shall be interpreted in accordance with the laws of the State of Florida without regard to its principles of conflicts of laws. The parties agree that venue for any legal proceedings arising out of this Contract shall be in the state courts of Okaloosa County, Florida.

Add the following two sub articles to Article 18.

18.09 Coordination of Contract Documents

- A. The following documents are integral parts of the Contract; a requirement occurring in one is as binding as though occurring in all. All parts of the Contract are complementary and describe and provide for a complete Work. In addition to the work and materials specified in the Standard Specifications as being included in any specific pay item, include in such pay items additional, incidental work not specifically mentioned, when so shown in the plans, or if indicated, or obvious and apparent, as being necessary for the proper completion of the Work under such pay item and not stipulated as being covered under other pay items.
- B. In cases of discrepancy, the governing order of the documents is as follows:
 1. Modifications issued after the execution of the Agreement
 2. Agreement between Owner & Contractor for Construction Contract
 3. Addenda issued after the Bid Specifications were advertised to potential Bidders
 4. Supplementary Conditions
 5. FDOT Standard Specifications for Road & Bridge Construction, Latest Edition
 6. EJDC General Conditions, 2013 Edition
 7. Technical Specifications
 8. Construction Drawings
 9. Computed dimensions govern over scaled dimensions

18.10 Construction Closeout Requirements to County

- A. Immediately after being notified by the Engineer that all other requirements of the Agreement have been completed Contractor shall complete the following items
 1. Signed Release of Liens;
 2. Certificate of Insurance for two year period, letter from Contractor stating Certificate of Insurance will be maintained for two (2) years;
 3. Certifications from Surety that Payment/Performance Bond shall remain in effect one year following final payment;
 4. Consent of Surety for Final Payment;
 5. Final Invoice with Engineer's Recommendation, final payment of this Contract shall be made within sixty (60) days after completion by the Contractor of all Work covered by the Agreement and acceptance of such Work by the County;
 6. Record (As-Built) Drawing

END OF DOCUMENT 00800 – SUPPLEMENTARY CONDITION

DOCUMENT 01010 – SUMMARY OF WORK

PART 1 - GENERAL

1.01 Work Covered by the Contract Documents

- A. The Project consists of the construction of 120 ft dock extension and wave attenuation fence perpendicular to existing dock; Pile Driving and Embedment of approximately 32 piles; Demolition of approximately 54 sf of exiting dock; Remove and replace decking on existing dock to match new dock and other WORK as shown on the construction drawings.
- B. The WORK covered by the CONTRACT Documents bid include the construction of 120 ft dock extension and wave attenuation fence perpendicular to existing dock; Pile Driving and Embedment of approximately 32 piles; Demolition of approximately 54 sf of exiting dock; Remove and replace decking on existing dock to match new dock; Construction of ramp access dock to match flush with existing ramp access dock; Construction of approximately 800 sf of decking on new dock and other WORK as shown on the construction drawings.

1.02 Work Sequence

- A. The work sequence will be determined by the CONTRACTOR.

1.03 Contractor's Use of Premises

- A. The CONTRACTOR use and responsibilities of premises as shown as shown on the construction drawings and described in the specifications.
- B. CONTRACTOR shall assume full responsibility for safety at the work site for all workers and visitors.
- C. The CONTRACTOR shall send proper notices, make all necessary arrangements, and perform all services required in the care and maintenance of all OWNER and public utilities within the construction limits.

PART 2 - PRODUCTS OMITTED

PART 3 - EXECUTION OMITTED

END OF DOCUMENT 01010 – SUMMARY OF WORK

DOCUMENT 01040 – PROJECT COORDINATION

PART 1 - GENERAL

1.01 Related Documents

- A. Drawings and general provisions of CONTRACT, including General and Supplementary Conditions and other Division 1 Specification Sections, apply to this Section.

1.02 Summary

- A. This Section specifies administrative and supervisory requirements necessary for Project coordination including, but not necessarily limited to:
 - 1. Coordination.
 - 2. Administrative and supervisory personnel.
 - 3. General installation provisions.
 - 4. Cleaning and protection.

1.03 Coordination

- A. Coordination: Coordinate construction activities included under various sections of these Specifications to assure efficient and orderly installation of each part of the WORK. Coordinate construction operations included under different sections of the Specifications that are dependent upon each other for proper installation, connection, and operation.
 - 1. Where installation of one part of the WORK is dependent on installation of other components, either before or after its own installation, schedule construction activities in the sequence required to obtain the best results.
 - 2. Where availability of space is limited, coordinate installation of different components to assure maximum accessibility for required maintenance, service and repair.
 - 3. Make adequate provisions to accommodate items scheduled for later installation.
- B. Where necessary, prepare memoranda for distribution to each party involved outlining special procedures required for coordination. Include such items as required notices, reports, and attendance at meetings.
 - 1. Prepare similar memoranda for the OWNER and separate CONTRACTORS where coordination of their WORK is required.
- C. Administrative Procedures: Coordinate scheduling and timing of required administrative procedures with other construction activities to avoid conflicts and ensure orderly progress of the WORK. Such administrative activities include, but are not limited to, the following:
 - 1. Preparation of schedules.
 - 2. Installation and removal of temporary facilities.
 - 3. Delivery and processing of submittals.
 - 4. Progress meetings.
 - 5. Project Close-out activities.

1.04 Submittal

- A. Coordination Drawings: Prepare and submit coordination Drawings where close and careful coordination is required for installation of products and materials fabricated off-site by separate entities, and where limited space availability necessitates maximum utilization of space for efficient installation of different components.
 - 1. Show the interrelationship of components shown on separate Shop Drawings.
 - 2. Indicate required installation sequences.
 - 3. Comply with requirements contained in Section 00700 Article 7.16

- B. Staff Names: Within 15 days of Notice to Proceed, submit a list of the CONTRACTOR's principal staff assignments, including the Superintendent and other personnel in attendance at the site; identify individuals, their duties and responsibilities; list their addresses and telephone numbers.

PART 2 - PRODUCTS OMITTED

PART 3 - EXECUTION

3.01 General Installation Provisions

- A. Inspection of Conditions: Require the Installer of each major component to inspect both the substrate and conditions under which WORK is to be performed. Do not proceed until unsatisfactory conditions have been corrected in an acceptable manner.
- B. Manufacturer's Instructions: Comply with manufacturer's installation instructions and recommendations, to the extent that those instructions and recommendations are more explicit or stringent than requirements contained in Contract Documents.
- C. Inspect materials or equipment immediately upon delivery and again prior to installation. Reject damaged and defective items.
- D. Provide attachment and connection devices and methods necessary for securing WORK. Secure WORK true to line and level. Allow for expansion and building movement.
- E. Visual Effects: Provide uniform joint widths in exposed WORK. Arrange joints in exposed WORK to obtain the best visual effect. Refer questionable choices to the Architect for final decision.
- F. Recheck measurements and dimensions, before starting each installation.
- G. Install each component during weather conditions and Project status that will ensure the best possible results. Isolate each part of the completed construction from incompatible material as necessary to prevent deterioration.
- H. Coordinate temporary enclosures with required inspections and tests, to minimize the necessity of uncovering completed construction for that purpose.
- I. Mounting Heights: Where mounting heights are not indicated, install individual components at standard mounting heights recognized within the industry for the particular application indicated. Refer questionable mounting height decisions to the Architect for final decision.

3.02 Cleaning and Protection

- A. During handling and installation, clean and protect construction in progress and adjoining materials in place. Apply protective covering where required to ensure protection from damage or deterioration at Substantial Completion.
- B. Clean and maintain completed construction as frequently as necessary through the remainder of the construction period. Adjust and lubricate operable components to ensure operability without damaging effects.
- C. Limiting Exposures: Supervise construction activities to ensure that no part of the construction, completed or in progress, is subject to harmful, dangerous, damaging, or otherwise deleterious exposure during the construction period. Where applicable, such exposures include, but are not limited to, the following:
 - 1. Excessive static or dynamic loading
 - 2. Excessive internal or external pressures
 - 3. Excessively high or low temperatures
 - 4. Thermal shock
 - 5. Excessively high or low humidity
 - 6. Air contamination or pollution
 - 7. Water
 - 8. Solvents
 - 9. Chemicals
 - 10. Puncture

11. Abrasion
12. Heavy traffic
13. Soiling, staining and corrosion
14. Bacteria
15. Rodent and insect infestation
16. Combustion
17. Electrical current
18. Improper lubrication
19. Unusual wear or other misuse
20. Contact between incompatible materials
21. Misalignment
22. Excessive weathering
23. Unprotected storage
24. Improper shipping or handling
25. Theft
26. Vandalism

END OF DOCUMENT 01040 -- PROJECT COORDINATION

DOCUMENT 01350 – WARRANTIES AND MANUALS

PART 1 – GENERAL

1.01 Warranties

- A. The CONTRACTOR shall provide a warranty on all materials and workmanship for at least one (1) year (min.) from the date of Substantial Completion as per the General Conditions.
- B. Additional Warranties apply to individual products, materials and / or assemblies; refer to each of the respective Specification sections to obtain the minimum required warranty information.

1.02 Operation Manuals

- A. The CONTRACTOR shall file (in one place) all operation, maintenance or other manuals received with equipment and upon completion of project, they must be presented to the OWNER with a notification, in writing, to the ENGINEER that this has been accomplished.

PART 2 - PRODUCTS OMITTED

PART 3 - EXECUTION OMITTED

END OF DOCUMENT 01350 – WARRANTIES AND MANUALS

DOCUMENT 01500 – TEMPORARY FACILITIES

PART 1 – GENERAL

1.01 Temporary Storage and Office

- A. The CONTRACTOR shall provide for his own use at project site, such storage and office space as deemed necessary.
- B. Provide Construction barriers and /or barricades, locations will be coordinated with the OWNER's Representative on the site, before installation.
- C. Trailers and sheds as necessary shall be located with-in the construction barriers, and only with the ENGINEER's and OWNER's approval.

1.02 Use Charges

- A. Usage charges for temporary services of facilities are not chargeable to the Owner or the ENGINEER.

1.03 Regulations

- A. Comply with requirements of local laws and regulations governing construction and local industry standards, in the installation of temporary services and facilities.

1.04 Standards

- A. Comply with the requirements of NFPA Code 241, "Building Construction and Demolition Operations", the ANSI-AIO Series standards for "Safety Requirements for Construction and Demolition", and the NECA National Joint Guideline NJG-6 "Temporary Job Utilities and Services".

1.05 Inspections

- A. Inspect and test each service before placing temporary utilities in use. Arrange for inspections and tests by governing authorities, and obtain certifications and permits for use.

1.06 Submittals

- A. Submit copies of reports and permits required or necessary for the installation and operation; including any reports of tests, inspections and / or permits necessary for installation, use and operation of the temporary facilities.

1.07 Temporary Services

- A. Toilet Facilities
 - 1. The CONTRACTOR shall provide temporary, on-site toilet facilities for the duration of construction. Cleaning shall be conducted in accordance with 2.07.
- B. General Utilities
 - 1. Water: The CONTRACTOR shall pay and provide for water needed for the Project during Construction.

1.08 Protection of Occupants

- A. Provide all warning signs, temporary fencing, barricades, supports, partitions, etc. as required to provide protection to the occupants, and to exclude unauthorized persons from the WORK areas.
 - 1. Comply with recognized standards and code requirements for erection of barricades where needed to prevent accidents. Paint with appropriate colors and warning signs to inform personnel at the site and the public of the hazard being protected against. Provide lighting where needed, including flashing red lights where appropriate.

1.09 Lifting Devices and Hoisting

- A. Provide cranes, hoists, towers and other lifting devices necessary for the proper and efficient movement of materials; provide operating personnel for equipment as required. Equipment shall be provided with proper guys, bracing and other safety devices as required by Local or State codes.
 - B. Remove towers and hoisting equipment when they are no longer needed, or as directed by the Architect.
- 1.10 First Aid Supplies
- A. Comply with governing regulations and recognized recommendations within the construction industry.
- 1.11 Rodent and Pest Control
- A. The CONTRACTOR shall retain a local exterminator and/or pest control company to perform extermination and control procedures at regular intervals so that the project will be relatively free of pests and their residues at all times during the construction project.
 - B. Any pest control operations will be done in a lawful manner using environmentally safe materials.
- 1.12 Collection and Disposal of Waste
- A. Establish a system for collection and disposal of waste materials. Enforce requirements strictly. Do not hold collected materials longer than seven (7) days during normal weather or three (3) days when the daily temperature is expected to rise above 80 degrees F. (27 degrees C).
 - B. Handle waste materials that are hazardous, dangerous, or unsanitary separately from other waste by containerizing.
 - C. Dispose of all waste material in a lawful manner.
- 1.13 Site Drainage
- A. Utilize the existing facilities for temporary drainage where feasible.
 - B. Maintain the existing site, existing building and construction areas free of water.
 - C. Dispose of rainwater in a lawful manner which will not result in flooding in project, nor endanger either existing or new WORK or temporary facilities.
 - D. Take necessary measures to prevent erosion.
- 1.14 Environmental Protection
- A. Conduct all construction activities, by means and methods that comply with any and all environmental regulations, to minimize the possibility that air, waterways and subsoil might be contaminated or polluted, or that other undesirable effects might result from the performance of WORK at the site.
- 1.15 General Protection
- A. Provide protection from damage, dust, etc. to all items in vicinity of the CONTRACT WORK including, but not limited to, existing building surfaces, finishes, items of equipment, utilities, etc. The CONTRACTOR will repair any new damage caused and / or created due to this construction project, to Owner's satisfaction at no additional cost to Owner. (Non-Construction related damage would be exempt from this clause)

PART 2 – PRODUCTS OMITTED

PART 3 - EXECUTION

3.01 General Operations

- A. Supervision: Limit the availability of temporary services and facilities to essential and intended uses to minimize waste and abuse.
 - 1. Do not permit temporary installation to be abused or endangered.

- B. Maintenance: Operate and maintain temporary services and facilities in good operating condition and in a safe and efficient manner until removal is authorized.
 - 1. Do not overload services or facilities.
 - 2. Protect from damage by freezing temperatures and/or similar elements.
 - 3. Do not allow unsanitary and/or hazardous conditions to develop or persist on site.
 - C. Maintain operation of temporary enclosures, heating, cooling, humidity control, ventilation and similar facilities on a 24-hour basis where required to achieve indicated results and avoid the possibility of damage to the WORK or to temporary facilities.
- 3.02 General Removal
- A. Remove each temporary service and facility promptly when need has ended, or when it is replaced by use of a permanent facility, but no later than Substantial Completion.
 - B. Complete or, if necessary, restore permanent WORK delayed because of interference with the temporary service or facility.
 - C. Repair all damaged WORK, clean exposed surfaces and replace any WORK which cannot be repaired.
 - D. Clean and renovate any permanent services and/or facilities that may have been used to provide a temporary service and/or facilities during the construction period.

END OF DOCUMENT 01500 – TEMPORARY FACILITIES

DOCUMENT 01700 – PROJECT CLOSE-OUT

PART 1 - GENERAL

1.01 Related Documents

- A. Drawings and general provisions of Contract, including General and Supplementary General Conditions and other Division-0 Specification sections, apply to the WORK of this section.

1.02 Description of Requirements

- A. Definitions: Close-out is hereby defined to include general requirements near end of the Contract Time, in preparation for final acceptance, final payment and normal termination of contract.
- B. Specific requirements for individual units of WORK are specified in sections of Division 0 through 16. Time of close-out is directly related to the "Substantial Completion", and must be a single time period for entire WORK.

1.03 Prerequisites to Substantial Completion

- A. General: Prior to requesting the ENGINEER's inspection for certification of Substantial Completion, complete the following and list any known exceptions (if any) in request.
 - 1. The in progress payment request will coincident with or first following date claimed, show either 100% completion for portion of WORK claimed as "Substantially Complete", or list incomplete items, value of incompleteness, and reasons for the items being incomplete.
 - 2. Include any supporting documentation required for completion as indicated in these Contract Documents.
 - 3. Submit statement showing accounting of any changes to the Contract Sum.
 - 4. Contractor shall notify and advise the OWNER of any pending insurance change over requirements.
 - 5. Submit specific warranties, workmanship / maintenance bonds, maintenance agreements, final certifications and similar documents.
 - 6. Obtain and submit releases enabling OWNER's full and unrestricted use of the WORK and access to services and utilities, including, where required, Occupancy Permits, operating certificates, and similar releases.
 - 7. Deliver tools, spare parts, extra stocks of materials, and similar physical items to the OWNER.
 - 8. Complete the start-up testing of the systems, and deliver the instructions of the operating systems to the OWNER and / or maintenance personnel. Discontinue (or change over) and remove from project site all temporary facilities and services, along with any construction tools and facilities, mock-ups, and similar elements.
 - 9. Complete the final cleaning up requirements, including the touch-up of any marred surfaces as required.
 - 10. Touch-up and otherwise repair and restore marred exposed finishes.

1.04 Inspection Procedures

- A. Upon the receipt of the Contractor's request. The Engineer of Record will either proceed with the inspection or advise the Contractor of any prerequisites not fulfilled.
- B. Following the initial inspection the Engineer of Record will either prepare a Certificate of Substantial Completion, or advise the Contractor of WORK that must be performed prior to the issuance of the certificate; and repeat the inspection when requested and assured that WORK has been substantially completed.
- C. The Contractor shall prepare a type written "punch-list" of items to be completed and attach it to the Substantial Completion Form. Results of the completed inspection will form initial "punch-list" for the final acceptance.

1.05 Prerequisites to Final Acceptance

- A. General: Prior to requesting the ENGINEER's final construction review for certification of final acceptance and final payment, as required by General Conditions, complete the following and list any known exceptions (if any) in request:
 - 1. Submit final payment request with final releases and supporting documentation not previously submitted and/or accepted. Include certificates of insurance for products and completed operations where required.
 - 2. Submit updated final statement, accounting for additional (final) changes to Contract Sum.
 - 3. Submit a certified copy of ENGINEER's "final punch-list" of Itemized WORK to be completed or corrected, stating that each item has been completed or otherwise resolved for acceptance, endorsed and dated by the ENGINEER.
 - 4. Submit Consent of Surety.
 - 5. Submit Certified and Notarized Lien Release stating that all parties have been or will be paid (showing amounts).
 - 6. Submit final liquidated damages settlement statement, acceptable to OWNER.
 - 7. Revise and submit evidence of final, continuing insurance coverage complying with insurance requirements.
- B. Review Procedure: Upon receipt of Contractor's notice that WORK has been completed, including punch-list items resulting from earlier construction reviews, and excepting incomplete items delayed because of acceptable circumstances. The ENGINEER will re-inspect the WORK.
- C. Upon completion of review, the ENGINEER will either prepare the Certificate of Final Acceptance or advise the Contractor of WORK not completed or of obligations not fulfilled as required for final acceptance.
- D. If necessary, procedure will be repeated.

1.06 Equipment Close-out

- A. General Operating / Maintenance Instructions: Arrange for each installer of the WORK that requires a continuing maintenance or operation, to meet with OWNER's personnel, at the project site, to provide basic instructions needed for the proper operation and any type of equipment maintenance.
 - 1. Include instructions by manufacturer's representatives where installers are not experts in the required procedures.
 - 2. Review maintenance manuals, record documentation, tools, spare parts and materials, lubricants, fuels, identification system, control sequences, hazards, cleaning and similar procedures and facilities.
 - 3. For operational equipment, demonstrate start-up, shut-down, emergency operations, noise and vibration adjustments, safety, economy /efficiency adjustments, and similar operations.
 - 4. Review maintenance and operations in relation with applicable warranties, agreements to maintain, bonds, and similar continuing commitments

1.07 Final Cleaning

- A. For any special cleaning requirements for the specific units of WORK, refer to the Technical Specifications.
- B. General cleaning during the progress of WORK is specified in General Conditions and as temporary services in "Temporary Facilities" section of this Division.
- C. Provide final cleaning of the WORK, at time indicated, consisting of cleaning each surface or unit of WORK to normal "clean" condition as expected for a first-class building cleaning and maintenance program.
- D. Comply with the manufacturer's instructions for cleaning operations. The following are examples, but not by way of limitation, of cleaning levels required:
 - 1. Remove labels which are not required as permanent labels.

2. Clean transparent materials, including mirrors and window/door glass, to a polished condition, removing any substances which are noticeable as a vision obscuring material. Replace broken glass and all damaged transparent materials.
 3. Clean all exposed exterior and interior hard-surfaced finishes, to a dirt-free condition, free of dust, stains, films and similar noticeable distracting substances. Except as otherwise indicated, avoid disturbance of natural weathering of exterior surfaces. Restore reflective surfaces to the original reflective condition.
 4. Wipe surfaces of mechanical and electrical equipment clean; remove any excess lubrication and other substances.
 5. Remove debris and surface dust from limited-access spaces including roofs, plenums, shafts, attics and similar spaces.
 6. Clean all light fixtures and lamps so as to function with full efficiency.
 7. Clean the project site (within limits of construction), including landscape areas, of litter and foreign substances. Sweep paved areas to a broom-clean condition; remove stains, petro-chemical spills and other foreign deposits.
- E. Removal of Protection: Except as otherwise indicated or requested by the ENGINEER and / or OWNER. Remove all temporary protection devices and facilities.
- F. Comply with safety standards and governing regulations for the cleaning operations. Do not burn waste materials at site, or bury any debris or excess materials on the OWNER's property, or discharge volatile or other harmful or dangerous materials into the drainage systems. Remove all waste materials from site and dispose of in a lawful manner.
- G. When extra materials are remaining after the completion of associated WORK, which have become the OWNER's property, dispose of these to OWNER's best advantage as directed.

END OF DOCUMENT 01700 – PROJECT CLOSE-OUT

DOCUMENT 01750 – RECORD DOCUMENTS

PART 1 – GENERAL

1.01 Related Documents

- A. Drawings and general provisions of CONTRACT, including General and Supplementary General Conditions and other Division-0 Specification sections, apply to the WORK of this section.

1.02 Summary

- A. Section includes administrative and procedural requirements for the record set of documents, including the following;
 - 1. Record Set of Drawings.
 - 2. Record Set of Specifications.
- B. Related Sections:
 - 1. Section 01700 - Project Close-Out.

1.03 Record Document Submittal

- A. Submit the following copies of the Record Documents during or prior to the Project Close-out:
 - 1. Provide one complete full size color copies, of the "marked-up" record set of drawings.
 - 2. Provide one complete "marked-up" record set of specifications.
 - 3. Provide one complete set of pile installation records.
- B. Copies are to be distributed, one of each type to the OWNER.

1.04 Use and Storage

- A. Store the Record Documents in the field office apart from the documents used for the construction. Do not use the Record Documents for construction purposes. Maintain Record Documents in good order and in a clean, dry, legible condition. Make all documents and samples available at all times for the OWNER, ENGINEERS and / or Building Inspectors as needed.
- B. Each CONTRACTOR is responsible for obtaining, recording, and maintaining the Record Documents information for its own WORK. The CONTRACTOR is responsible for coordinating the information, where information from more than one CONTRACTOR is to be integrated with the information from other CONTRACTORS to form one combined record.

1.05 Record Drawings

- A. Mark the Record Drawings to show the actual installation where the locations vary from the installation locations shown originally. Give particular attention to information on the concealed elements that would be difficult to identify or measure and record later. Items required to be marked include, but are not limited to, the following:
 - 1. Measured horizontal and vertical locations of underground utilities and other appurtenances, referenced to permanent surface improvements.
 - 2. Locations of concealed internal utilities and appurtenances.
 - 3. Actual equipment locations.
 - 4. Revisions to routing of piping and conduits.
 - 5. Duct size and routing.
 - 6. Depths of foundations below the first floor.
 - 7. Revisions to electrical circuitry.
 - 8. Dimensional changes to the Drawings.
 - 9. Revisions to details on the Drawings.
 - 10. Details not on the original CONTRACT Drawings.
 - 11. Changes made following the OWNER's written orders.

12. Changes made by Addendum, Change Orders, Requests for Information (RFIs), or ENGINEER's Supplemental Instructions (ASIs).
- B. Mark the Record Drawings and Shop Drawings completely and accurately. Utilize personnel proficient at recording graphic information in the production of the marked-up Record Documents.

1.06 Record Specifications

- A. Mark the Record Specifications to show Addendums, Change Orders, Requests for Information (RFIs), or ENGINEER's Supplemental Instructions (ASIs).
- B. Indicate on the Record Specifications the actual product that was installed where the installation varies from the Specifications, addenda and CONTRACT modifications.
 1. Give particular attention to information on concealed products and the installations that cannot be readily identified and recorded later.
 2. Mark the Record copy with the propriety name and model number of products, materials and equipment furnished, including substitutions and product options selected.
 3. Record the name of manufacturer, supplier, installer and other necessary to provide a record of selections made.
 4. For each principal product, indicate whether the record Product Data has been submitted in the operation and maintenance manuals instead of submitted as record Product Data.
 5. Note related Change Orders and turnover drawings where applicable.

PART 2 – PRODUCT OMITTED

PART 3 – EXECUTION

3.01 Preparation

- A. Daily mark the Record Documents to show the actual conditions where the installation varies from that shown originally. Require the individual or entity who obtained the record data, whether that individual or entity is the Installer, Sub-contractor or similar entity to provide the information for the preparation of the corresponding marked-up Record Set of Drawings.
 1. Give particular attention to information on concealed elements that would be difficult to identify or measure and record later.
 2. Accurately record information in an acceptable drawing technique.
 3. Record data as soon as possible after obtaining it.
 4. Record and check the mark-up before enclosing the concealed installations.
 5. Record the changes and modifications as they occur. Do not wait until the end of the Project.

3.02 Recording

- A. During construction, maintain an extra set of the CONTRACT Documents specifically for the purpose of creating the Record Documents. Keep them separate from the set used for construction.
 1. Stamp each sheet of the Record Drawings and the cover of the Record Specifications in the lower right-hand corner with a reasonably large ink stamp to read "Record Set".
 2. Mark Record Set Documents with a red pencil or pen. Use other colors to distinguish between changes for different categories of the WORK at the same location or for clarity. (All marks shall be photo reproducible.)
 3. Mark the record documents completely and accurately.
 4. Indicate any additional important information that was either shown schematically or omitted from the CONTRACT Documents.
 5. Mark the Record Documents to indicate actual WORK done that deviates from the CONTRACT Documents.
- B. Maintain the Record Documents in good order and in a clean, dry, legible condition.
- C. Make all Record Documents and samples available at all times for the OWNER, ENGINEERS and / or Building Inspectors as needed.

-
- D. After completing the preparation of the Record Documents, prepare the drawings and specifications for distribution.
 - E. Submit the Record Documents, whether or not any changes and / or additional information was recorded.

END OF DOCUMENT 01750 – RECORD DOCUMENTS

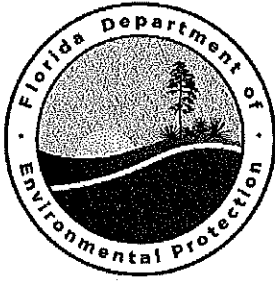

Appendix A
**Florida Department of
Environmental Protection**

Northwest District
160 W Government Street, Suite 308
Pensacola, Florida 32502-5740

Rick Scott
Governor

Carlos Lopez-Cantera
Lt. Governor

Noah Valenstein
Secretary

July 18, 2017

Okaloosa County Public Works
c/o Scott Bitterman
1759 S. Ferdon Boulevard
Crestview, Florida 32536
Rpetrey@co.okaloosa.fl.us

File No.: 0352545-003-EE, Okaloosa County

Dear Mr. Bitterman:

On June 16, 2017, we received your request for verification of exemption to perform the following activities:

Remove a 54 square foot terminal platform and add a dock extension to an existing public park dock with a wave attenuation fence for a total of 1,000 square feet or less of overwater surface area within Hand Cove / Poquito Bayou, Class III Florida Waterbody, Prohibited shellfish harvest area, parcel ID No. 31-1S-23-0120-0000-Park, 4 Bay Street Shalimar, Florida 32579, in Section 31, Township 1 South, Range 23 West, of Okaloosa County at Latitude 30°27'20.63" North, Longitude 86°35'14.71" West.

Your request has been reviewed to determine whether it qualifies for (1) regulatory exemption, (2) proprietary authorization (related to state-owned submerged lands), and (3) federal approval that may be necessary for work in wetlands or waters of the United States.

Your project qualifies for all three. However, this letter does not relieve you from the responsibility of obtaining other federal, state, or local authorizations that may be required for the activity.

If you change the project from what you submitted, the authorization(s) granted may no longer be valid at the time of commencement of the project. Please contact us prior to beginning your project if you wish to make any changes.

If you have any questions regarding this matter, please contact Douglas Sprague at the letterhead address at (850) 595-0579 or Douglas.sprague@dep.state.fl.us.

1. Regulatory Review – Verified

Based on the information submitted, the Department has verified that the activity as proposed is exempt under Chapter 62-330.051(5)(b), Florida Administrative Code, from the need to obtain a regulatory permit under Part IV of Chapter 373 of the Florida Statutes.

This exemption verification is based on the information you provided the Department and the statutes and rules in effect when the information was submitted. This verification may not be valid if site conditions materially change, the project design is modified, or the statutes or rules governing the exempt activity are amended. In the event you need to re-verify the exempt status for the activity, a new request and verification fee will be required. Any substantial modifications to the project design should be submitted to the Department for review, as changes may result in a permit being required.

2. Proprietary Review – Granted

The Department acts as staff to the Board of Trustees of the Internal Improvement Trust Fund (Board of Trustees) and issues certain authorizations for the use of sovereign submerged lands. The Department has the authority to review activities on sovereign submerged lands under Chapters 253 and 258 of the Florida Statutes, and Chapters 18-20 and 18-21 of the Florida Administrative Code.

The activity appears to be located on sovereign submerged lands owned by the Board of Trustees. The activity is not exempt from the need to obtain the applicable proprietary authorization. As staff to the Board of Trustees, the Department has reviewed the activity described above, and has determined that the activity qualifies for an automatic consent by rule under Rule 18-21.005(1)(b) and Section 253.77 of the Florida Statutes to construct and use the activity on the specified sovereign submerged lands, as long as the work performed is located within the boundaries as described herein and is consistent with the terms and conditions herein. No further application is required for this consent by rule.

Special Consent Conditions

1. The applicant agrees to indemnify, defend and hold harmless the Board of Trustees and the State of Florida from all claims, actions, lawsuits and demands in any form arising out of the authorization to use sovereignty submerged lands or the applicant's use and construction of structures on sovereignty submerged lands. This duty to indemnify and hold harmless will include any and all liabilities that are associated with the structure or activity including special assessments or taxes that are now or in the future assessed against the structure or activity during the period of the authorization.
2. Failure by the Board of Trustees to enforce any violation of a provision of the authorization or waiver by the Board of Trustees of any provision of the authorization will not invalidate the provision not enforced or waived, nor will the failure to enforce or a waiver prevent the Board of Trustees from enforcing the unenforced or waived provision in the event of a violation of that provision.
3. Applicant binds itself and its successors and assigns to abide by the provisions and conditions set forth in the authorization. If the applicant or its successors or assigns fails or refuses to comply with the provisions and conditions of the authorization, the authorization may be terminated by the Board of Trustees after written notice to the applicant or its successors or assigns. Upon receipt of such notice, the applicant or its successors or assigns will have thirty (30) days in which to correct the violations. Failure to correct the violations within this period will result in the automatic revocation of this authorization.

4. All costs incurred by the Board of Trustees in enforcing the terms and conditions of the authorization will be paid by the applicant. Any notice required by law will be made by certified mail at the address shown on page one of the authorization. The applicant will notify the Board of Trustees in writing of any change of address at least ten days before the change becomes effective.

5. This authorization does not allow any activity prohibited in a conservation easement or restrictive covenant that prohibits the activity.

6. All on-site project personnel are responsible for observing water-related activities for the presence of sea turtles and manatee(s). All in-water operations, including vessels, must be shut down if a sea turtle or manatee comes within 50 feet of the operation. Activities will not resume until the animal(s) has moved beyond the 50-foot radius of the project operation, or until 30 minutes elapses if the animal(s) has not reappeared within 50 feet of the operation. Animals must not be herded away or harassed into leaving.

7. Any collision with or injury to a sea turtle or manatee shall be reported immediately to the Florida Fish and Wildlife Conservation Commission (FWC) Hotline at 1-888-404-3922, and to FWC at ImperiledSpecies@myFWC.com. Any collision with and/or injury to a sea turtle should also be reported immediately to the Sea Turtle Stranding and Salvage Network (STSSN) at SeaTurtleStranding@myfwc.com.

General Conditions for Authorizations for Activities

All authorizations granted by rule or in writing under Rule 18-21.005, F.A.C., except those for geophysical testing, shall be subject to the general conditions as set forth in paragraphs (a) through (i) below. The general conditions shall be part of all authorizations under this chapter, shall be binding upon the grantee, and shall be enforceable under Chapter 253 or 258, Part II, F.S.

(a) Authorizations are valid only for the specified activity or use. Any unauthorized deviation from the specified activity or use and the conditions for undertaking that activity or use shall constitute a violation. Violation of the authorization shall result in suspension or revocation of the grantee's use of the sovereignty submerged land unless cured to the satisfaction of the Board.

(b) Authorizations convey no title to sovereignty submerged land or water column, nor do they constitute recognition or acknowledgment of any other person's title to such land or water.

(c) Authorizations may be modified, suspended or revoked in accordance with their terms or the remedies provided in Sections 253.04 and 258.46, F.S., or Chapter 18-14, F.A.C.

(d) Structures or activities shall be constructed and used to avoid or minimize adverse impacts to sovereignty submerged lands and resources.

(e) Construction, use, or operation of the structure or activity shall not adversely affect any species which is endangered, threatened or of special concern, as listed in Rules 68A-27.003, 68A-27.004, and 68A-27.005, F.A.C.

(f) Structures or activities shall not unreasonably interfere with riparian rights. When a court of competent jurisdiction determines that riparian rights have been unlawfully affected, the structure or activity shall be modified in accordance with the court's decision.

(g) Structures or activities shall not create a navigational hazard.

(h) Structures shall be maintained in a functional condition and shall be repaired or removed if they become dilapidated to such an extent that they are no longer functional. This shall not be construed to prohibit the repair or replacement subject to the provisions of Rule 18-21.005, F.A.C., within one year, of a structure damaged in a discrete event such as a storm, flood, accident, or fire.

(i) Structures or activities shall be constructed, operated, and maintained solely for water dependent purposes, or for non-water dependent activities authorized under Paragraph 18-21.004(1)(f), F.A.C., or any other applicable law.

3. Federal Review – SPGP Approved

Your proposed activity as outlined in your application and attached drawings qualifies for Federal authorization pursuant to the State Programmatic General Permit V, and a **SEPARATE permit** or authorization **will not be required** from the Corps. Please note that the Federal authorization expires on July 26, 2021. However, your authorization may remain in effect for up to 1 additional year, if provisions of Special Condition B.27 of the SPGP V permit instrument are met. You, as permittee, are required to adhere to all General Conditions and Special Conditions that may apply to your project." Special conditions required for your project are attached. A copy of the SPGP V with all terms and conditions and the General Conditions may be found at <http://www.saj.usace.army.mil/Divisions/Regulatory/sourcebook.htm>."

Authority for review - an agreement with the USACOE entitled "Coordination Agreement Between the U. S. Army Corps of Engineers (Jacksonville District) and the Florida Department of Environmental Protection, or Duly Authorized Designee, State Programmatic General Permit", Section 10 of the Rivers and Harbor Act of 1899, and Section 404 of the Clean Water Act.

Additional Information

Please retain this letter. The activities may be inspected by authorized state personnel in the future to ensure compliance with appropriate statutes and administrative codes. If the activities are not in compliance, you may be subject to penalties under Chapter 373, F.S., and Chapter 18-14, F.A.C.

Notice of Rights

This action is final and effective on the date filed with the Clerk of the Department unless a petition for an administrative hearing is timely filed under Sections 120.569 and 120.57, F.S., before the deadline for filing a petition. On the filing of a timely and sufficient petition, this action will not be final and effective until further order of the Department. Because the administrative hearing process is

designed to formulate final agency action, the filing of a petition means that the Department's final action may be different from the position taken by it in this notice.

Petition for Administrative Hearing

A person whose substantial interests are affected by the Department's action may petition for an administrative proceeding (hearing) under Sections 120.569 and 120.57, F.S. Pursuant to Rule 28-106.201, F.A.C., a petition for an administrative hearing must contain the following information:

- (a) The name and address of each agency affected and each agency's file or identification number, if known;
- (b) The name, address, any email address, any facsimile number, and telephone number of the petitioner; the name, address, and telephone number of the petitioner's representative, if any, which shall be the address for service purposes during the course of the proceeding; and an explanation of how the petitioner's substantial interests are or will be affected by the agency determination;
- (c) A statement of when and how the petitioner received notice of the agency decision;
- (d) A statement of all disputed issues of material fact. If there are none, the petition must so indicate;
- (e) A concise statement of the ultimate facts alleged, including the specific facts that the petitioner contends warrant reversal or modification of the agency's proposed action;
- (f) A statement of the specific rules or statutes that the petitioner contends require reversal or modification of the agency's proposed action, including an explanation of how the alleged facts relate to the specific rules or statutes; and
- (g) A statement of the relief sought by the petitioner, stating precisely the action that the petitioner wishes the agency to take with respect to the agency's proposed action.

The petition must be filed (received by the Clerk) in the Office of General Counsel of the Department at 3900 Commonwealth Boulevard, Mail Station 35, Tallahassee, Florida 32399-3000. Also, a copy of the petition shall be mailed to the applicant at the address indicated above at the time of filing.

Time Period for Filing a Petition

In accordance with Rule 62-110.106(3), F.A.C., petitions for an administrative hearing by the applicant must be filed within 21 days of receipt of this written notice. Petitions filed by any persons other than the applicant, and other than those entitled to written notice under Section 120.60(3), F.S. must be filed within 21 days of publication of the notice or within 21 days of receipt of the written notice, whichever occurs first. Under Section 120.60(3), F.S., however, any person who has asked the Department for notice of agency action may file a petition within 21 days of receipt of such notice, regardless of the date of publication. The failure to file a petition within the appropriate time period shall constitute a waiver of that person's right to request an administrative determination (hearing) under Sections 120.569 and 120.57, F.S., or to intervene in this proceeding and participate as a party to it. Any subsequent intervention (in a proceeding initiated by another party) will be only at the discretion of the presiding officer upon the filing of a motion in compliance with Rule 28-106.205, F.A.C.

Extension of Time

Under Rule 62-110.106(4), F.A.C., a person whose substantial interests are affected by the Department's action may also request an extension of time to file a petition for an administrative hearing. The Department may, for good cause shown, grant the request for an extension of time. Requests for extension of time must be filed with the Office of General Counsel of the Department at 3900 Commonwealth Boulevard, Mail Station 35, Tallahassee, Florida 32399-3000, before the applicable deadline for filing a petition for an administrative hearing. A timely request for extension of time shall toll the running of the time period for filing a petition until the request is acted upon.

Mediation

Mediation is not available in this proceeding.

FLAWAC Review

The applicant, or any party within the meaning of Section 373.114(1)(a) or 373.4275, F.S., may also seek appellate review of this order before the Land and Water Adjudicatory Commission under Section 373.114(1) or 373.4275, F.S. Requests for review before the Land and Water Adjudicatory Commission must be filed with the Secretary of the Commission and served on the Department within 20 days from the date when the order is filed with the Clerk of the Department.

Judicial Review

Any party to this action has the right to seek judicial review pursuant to Section 120.68, F.S., by filing a Notice of Appeal pursuant to Rules 9.110 and 9.190, Florida Rules of Appellate Procedure, with the Clerk of the Department in the Office of General Counsel, 3900 Commonwealth Boulevard, M.S. 35, Tallahassee, Florida 32399-3000; and by filing a copy of the Notice of Appeal accompanied by the applicable filing fees with the appropriate District Court of Appeal. The Notice of Appeal must be filed within 30 days from the date this action is filed with the Clerk of the Department.

Thank you for applying to the Submerged Lands and Environmental Resource Permit Program. If you have any questions regarding this matter, please contact Douglas Sprague at the letterhead address, at 850-595-0579, or at douglas.sprague@dep.state.fl.us.

Executed in Orlando, Florida.

STATE OF FLORIDA DEPARTMENT
OF ENVIRONMENTAL PROTECTION

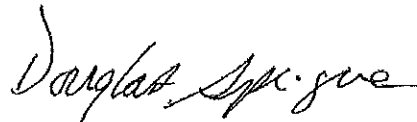

Douglas Sprague
Submerged Lands and Environmental
Resources Program
Northwest District

TAM:ds

Copies To:

Terry Hayes, U.S. Army Corps of Engineers, Terry.s.hayes@usace.army.mil
Okaloosa County, mmartinez@co.okaloosa.fl.us jautrey@co.okaloosa.fl.us
sbitterman@co.okaloosa.fl.us propertyappraiser@okaloosapa.com
Amy Allen, Okaloosa Parks Coordinator, aallen@co.okaloosa.fl.us
Duncan Greer, Agent, Taylor Engineering, Inc. Dgreer@tayloengineering.com

Enclosures:

Subsection / Paragraph 62-330.051(5)(b), F.A.C. and/or Section 403.813(1)(b), F.S., 1 page.
Special Conditions Related to All Review and Authorizations, 6 pages.
General Conditions for Federal Authorization for SPGP V, 2 pages.
Department of the Army Permit Transfer for SPGP V, 1 page.
Construction Guidelines in Florida for Minor Piling-Supported Structures, 2 pages
Project drawings, 6 pages

CERTIFICATE OF SERVICE

The undersigned duly designated deputy clerk hereby certifies that this order and all attachments were sent electronically on the filing date below to the above listed persons:

FILING AND ACKNOWLEDGMENT

FILED, on this date, pursuant to 120.52, Florida Statutes, with the designated Department Clerk, receipt of which is hereby acknowledged.

Clerk  Date July 18, 2017

62-330.051 Exempt Activities.

The activities meeting the limitations and restrictions below are exempt from permitting. However, if located in, on, or over state-owned submerged lands, they are subject to a separate authorization under Chapters 253 and 258, F.S., and Chapters 18-18, 18-20, and 18-21, F.A.C., as applicable.

(5) Dock, Pier, Boat Ramp and Other Boating-related Work –

(b) Installation of private docks, piers, and recreational docking facilities, and installation of local governmental piers and recreational docking facilities, in accordance with Section 403.813(1)(b), F.S. This includes associated structures such as boat shelters, boat lifts, and roofs, provided:

1. The cumulative square footage of all structures located over wetlands and other surface waters does not exceed the limitations in Section 403.813(1)(b), F.S.;
2. No structure is enclosed on more than three sides with walls and doors;
3. Structures are not used for residential habitation or commercial purposes, or storage of materials other than those associated with water dependent recreational use; and
4. Any dock and associated structure shall be the sole dock as measured along the shoreline for a minimum distance of 65 feet, unless the parcel of land or individual lot as platted is less than 65 feet in length along the shoreline, in which case there may be one exempt dock allowed per parcel or lot.

403.813 Permits issued at district centers; exceptions.

(1) A permit is not required under this chapter, chapter 373, chapter 61-691, Laws of Florida, or chapter 25214 or chapter 25270, 1949, Laws of Florida, for activities associated with the following types of projects; however, except as otherwise provided in this subsection, nothing in this subsection relieves an applicant from any requirement to obtain permission to use or occupy lands owned by the Board of Trustees of the Internal Improvement Trust Fund or any water management district in its governmental or proprietary capacity or from complying with applicable local pollution control programs authorized under this chapter or other requirements of county and municipal governments:

(b) The installation and repair of mooring pilings and dolphins associated with private docking facilities or piers and the installation of private docks, piers and recreational docking facilities, or piers and recreational docking facilities of local governmental entities when the local governmental entity's activities will not take place in any manatee habitat, any of which docks:

1. Has 500 square feet or less of over-water surface area for a dock which is located in an area designated as Outstanding Florida Waters or 1,000 square feet or less of over-water surface area for a dock which is located in an area which is not designated as Outstanding Florida Waters;
2. Is constructed on or held in place by pilings or is a floating dock which is constructed so as not to involve filling or dredging other than that necessary to install the pilings;
3. Shall not substantially impede the flow of water or create a navigational hazard;
4. Is used for recreational, noncommercial activities associated with the mooring or storage of boats and boat paraphernalia; and
5. Is the sole dock constructed pursuant to this exemption as measured along the shoreline for a distance of 65 feet, unless the parcel of land or individual lot as platted is less than 65 feet in length along the shoreline, in which case there may be one exempt dock allowed per parcel or lot.

Nothing in this paragraph shall prohibit the department from taking appropriate enforcement action pursuant to this chapter to abate or prohibit any activity otherwise exempt from permitting pursuant to this paragraph if the department can demonstrate that the exempted activity has caused water pollution in violation of this chapter.

Special Conditions Related to All Review and Authorizations

In addition to the conditions specified above, the following Special Conditions apply to all projects reviewed and/or authorized under the SPGP V.

1. The District Engineer reserves the right to require that any request for authorization under this SPGP V be evaluated as an Individual Permit. Conformance with the terms and conditions of the SPGP V does not automatically guarantee Federal authorization.
2. On a case-by-case basis the Corps may impose additional Special Conditions which are deemed necessary to minimize adverse environmental impacts.
3. Failure to comply with all conditions of the Federal authorizations under the SPGP V would constitute a violation of the Federal authorization.
4. No structure or work shall adversely affect or disturb properties listed in the National Register of Historic Places or those eligible for inclusion in the National Register. Prior to the start of work, the Applicant/Permittee or other party on the Applicant's/Permittee's behalf, shall conduct a search of known historical properties by contracting a professional archaeologist, and contacting the Florida Master Site File at 850-245-6440 or SiteFile@dos.state.fl.us. The Applicant/Permittee can also research sites in the National Register Information System (NRIS). Information can be found at <http://www.cr.nps.gov/nr/research>.
 - a. If, during the initial ground disturbing activities and construction work, there are archaeological/cultural materials unearthed (which shall include, but not be limited to: pottery, modified shell, flora, fauna, human remains, ceramics, stone tools or metal implements, dugout canoes or any other physical remains that could be associated with Native American cultures or early colonial or American settlement), the Permittee shall immediately stop all work in the vicinity and notify the Compliance and Review staff of the State Historic Preservation Office at 850-245-6333 and the Corps Regulatory Project Manager to assess the significance of the discovery and devise appropriate actions, including salvage operations. Based, on the circumstances of the discovery, equity to all parties, and considerations of the public interest, the Corps may modify, suspend or revoke the permit in accordance with 33 CFR Part 325.7.
 - b. In the unlikely event that human remains are identified, they will be treated in accordance with Section 872.05, Florida Statutes; all work in the vicinity shall immediately cease and the local law authority, the State Archaeologist (850-245-6444), and the Corps Regulatory Project Manager shall immediately be notified. Such activity shall not resume unless specifically authorized by the State Archaeologist and the Corps.
5. No work shall be authorized under the SPGP V which proposes the use of prefabricated modules for habitat creation, restoration, or enhancement except as allowed in Special Condition 15 for *Living Shorelines* of the *Shoreline Stabilization* category.

6. The Design and construction of a Project must comply with the following.

- a. Where aquatic vegetation is present, adverse impacts to aquatic vegetation from construction of piling-supported structures may be avoided/minimized by adherence to, or

employing alternative construction techniques that provide a higher level of protection than, the protective criteria in the joint U.S. Army Corps of Engineers'/National Marine Fisheries Service's "*Construction Guidelines in Florida for Minor Piling-Supported Structures Constructed in or over Submerged Aquatic Vegetation (SAV), Marsh or Mangrove Habitat*" U.S. Army Corps of Engineers/National Marine Fisheries Service August 2001 (updated June 2008). Unless otherwise specifically approved by the National Marine Fisheries Service, where aquatic vegetation is present, piling-supported structures authorized under the SPGP V must comply with, or provide a higher level of protection than, the criteria contained in the referenced construction guidelines. Mangrove impacts are limited to the removal of mangroves along 4 linear feet of shoreline to accommodate a 4-ft-wide access walkway associated with a dock that meets the above guidelines.

b. Additionally, because of concerns about adverse impacts to the endangered Johnson's seagrass (*Halophila johnsonii*) in the lagoon and canal systems on Florida's east coast from Sebastian Inlet (Brevard County) south to and including central Biscayne Bay (Miami-Dade County), the following requirements must be met:

(1) Piling-supported structures must comply with, or provide a higher level of protection than, the criteria contained in the construction guidelines titled "*Key for Construction Conditions for Docks or Other Minor Structures Constructed in or Over Johnson's seagrass (Halophila johnsonii)*" National Marine Fisheries Service/U.S. Army Corps of Engineers - February 2002 (updated October 2002)."

(2) Removal of derelict vessels must comply with the practices of Special Condition 18.

(3) All other activities will have no effect on Johnson's seagrass, i.e., no seagrass is present.

c. The presence of seagrass will be determined utilizing the attached "*Submerged Aquatic Vegetation Survey Guidelines*".

7. For projects in waters accessible to sea turtles, Smalltooth sawfish, Gulf sturgeon, or Shortnose sturgeon, the Permittee will utilize the "*Sea Turtle and Smalltooth Sawfish Construction Conditions*" and the following additions:

a. Any collision(s) with and/or injuries to any whale, or sturgeon occurring during the construction of a project, shall be reported immediately to NMFS's Protected Resources Division (PRD) at (727-824-5312).

b. Reports to NMFS's Protected Resources Division (PRD) may be made by email to takereport.nmfsser@noaa.gov.

c. Sea turtle and marine mammal stranding/rescue organizations' contact information is available by region at <http://www.nmfs.noaa.gov/pr/health/networks.htm>.

d. Smalltooth sawfish encounters shall be reported to <http://www.flmnh.ufl.edu/fish/sharks/sawfish/sawfishencounters.html>.

e. All work must occur during daylight hours.

8. The Permittee is responsible for obtaining any “take” permits required under the U.S. Fish and Wildlife Service’s regulations governing compliance with the Migratory Bird Treaty Act or the Bald and Golden Eagle Protection Act. The Permittee should contact the appropriate local office of the U.S. Fish and Wildlife Service to determine if such “take” permits are required for a particular activity.

9. The Permittee is responsible for compliance with 50 CFR 224.103(c) prohibiting approach within 500 yards of a right whale, with limited exceptions.

10. Turbidity control measures shall be used throughout construction to control erosion and siltation to ensure there are no violations of state or federal water quality standards. Turbidity control measures shall be: (1) for the smallest practicable area; (2) monitored daily to ensure listed species are not entangled or trapped in the project area; (3) shall be removed promptly upon project completion and the return of water quality conditions; (4) and shall not block entry to or exit from designated critical habitat. Siltation barriers shall be made of material in which listed species cannot become entangled (i.e., reinforced impermeable polycarbonate vinyl fabric [PVC]).

a. Turbidity curtains are not required where not practical in dynamic systems such as surf zones and could actually do more harm than good if the curtains become detached (e.g., they could entrap pelagic organisms and become entangled around benthic organisms, such as coral).

b. Turbidity barriers are not required if installation of single piling in deep water since is unlikely to adversely affect water quality.

11. In-water rope or chain must meet the following requirements: Industrial grade metal

chains or heavy cables that do not readily loop and tangle; All in-water lines (rope and cable) must be thick and taut and cannot have excess line in the water; Lines can be enclosed in a plastic or rubber sleeve/tube to add rigidity.

12. No work shall occur where hard bottom or any hard or coral including ESA-listed coral species are present within the footprint of the project.

13. No work shall occur that results in removal of mangroves (including prop roots), except:

a. as provided by Special Condition 6.a.; or,

b. for removal of mangroves growing at the foot or from an existing seawall whose removal needed to repair the seawall.

14. No work shall occur that results in impacts to seagrass except as provided by Special Condition 6.

15. (For *Docks, Piers, Associated Facilities, and Other Minor Piling-Supported Structures and Boat Ramps and Boat Launch Areas and Structures Associated with Such Ramps or Launch Areas.*)

a. Aids to Navigation and Private Aids to Navigation (e.g. attached to the structures authorized by the SPGP) must be approved by and installed in accordance with U.S. Coast Guard requirements.

b. Temporary structures associated with marine events will be removed and the site restored upon completion of the event.

c. (For multi-family residential docks (e.g., condos, trailer parks, apartment complexes) designated for fishing or vessel storage, for temporary marine event pile-supported structures involving high speed vessel traffic or fishing, and for commercial or public boat ramps.) Install educational signs as follows in a visible location to alert boaters of listed species in the area susceptible to vessel strikes or hook-and-line captures. NMFS website (http://sero.nmfs.noaa.gov/protected_resources/section_7/protected_species_educational_signs/index.html) provides sign installation guidance and most current version of the signs.

(1) All commercial and public boat ramps shall install the Save Sea Turtle, Sawfish, and Dolphin sign.

(2) If the Project occurs within the range of Gulf, Atlantic, or Shortnose sturgeon, the Permittee will install and maintain the *Report Sturgeon* sign.

(3) If the Project occurs within 14 miles of North Atlantic Right Whale critical habitat, the Permittee will install and maintain the *Help Protect North Atlantic Right Whales* sign.

d. Project construction will take place from uplands or from floating equipment (e.g., barge); prop or wheel-washing is prohibited.

16. (For *Transient activities*.)

a. Temporary structures shall not block access of species to an area such as preventing movement in or out of a river or channel.

b. (For *scientific sampling, measurement, and monitoring devices*.) No later than 24 months from initial installation, or upon completion of data acquisition, whichever comes first, the measuring device and any other structure or fills associated with that device (e.g., anchors, buoys, lines) must be removed and the site must be restored to pre-construction elevations.

17. (For *Living Shorelines* of the *Shoreline Stabilization* category.)

a. Only native plant species will be planted.

b. Not more than 500 linear feet in length, not more than 35 ft waterward of the high tide line (note that FAC 62-330 limits to 10 feet of the mean high water line) or result in more than 0.5 ac area between the natural shoreline and the structure.

c. No discharge of earthen fill material, other than earthen material associated with vegetative planting, is not authorized.

d. Construction, maintenance and removal of approved permanent, shore-parallel wave attenuation structures are authorized. Approved permanent wave attenuation materials include oyster breakwaters (described above), clean limestone boulders, and prefabricated structures made of concrete and rebar that are designed in a manner that cannot trap sea turtles, Smalltooth sawfish, or sturgeon. Reef balls that are not open on the bottom, triangle structures with a top opening of at least 3 feet between structures, and reef discs stacked on a pile may be used.

e. (For oyster breakwaters).

(1) Reef materials shall be placed in a manner to ensure that materials (e.g., bagged oyster shell, oyster mats, loose cultch surrounded and contained by a stabilizing feature, reef balls, and reef cradles) will remain stable and prevent movement of materials to surrounding areas.

(2) Materials must be placed in designated locations (i.e., shall not be indiscriminately/randomly dumped) and shall not be placed outside of the total project limits.

18. (For *Subaqueous Utility Lines* of the *Transient Activities* category.)

a. A Frac-out Contingency Plan similar to the attached plan will be developed, submitted with the application and then followed.

b. All subaqueous transmission lines crossing over, under, or in flood control channels/canals in Federal projects (either federally or locally maintained) which are installed with horizontal direction drilling (HDD) shall ensure the top of the HDD boring is a minimum of 10 feet beneath the bottom of the channel plus a minimum 25 feet outside the channel edges and the estimated total drilling fluid pressure is less than 10 psi. Projects not in compliance with these criteria shall not be eligible for authorization under SPGP V.

c. The Permittee shall, upon completion of work, provide an as-built survey showing the horizontal and vertical location (X-Y-Z coordinates in NAD 83 and NAVD 88) of the object below the channel as it enters and exits the design edges of the authorized width of the channel, plus a minimum of 25 feet outside the channel edges.

19. (For *Removal of Derelict Vessels* of the *Transient Activities* category.)

a. Removal of marine debris shall require visual confirmation (e.g., divers, swimmers, camera) that the item can be removed without causing further damage to aquatic resources.

b. If an item cannot be removed without causing harm to surrounding coral, the item will be disassembled as much as practicable so that it no longer can accidentally harm or trap species.

c. Monofilament debris will be carefully cut loose from coral so as not to cause further harm. Under no circumstance will line be pulled through coral since this could cause breakage of coral.

d. Marine debris shall be lifted straight up and not be dragged through seagrass beds, coral, or hard bottom habitats. Debris shall be properly disposed of in appropriate facilities in accordance with applicable federal and state requirements.

20. For concrete piles installed by impact hammer:
 - a. The piles will be less than or equal to than 24 inches in diameter; and
 - b. Not more than 10 piles will be installed per day if in open water; or,
 - c. Not more than 5 piles will be installed per day in a *confined space*. A *confined space* is defined as any area that has a solid object (e.g., shoreline, seawall, jetty) or structure within 150 feet of the pile installation site that would effectively serve as a barrier or otherwise prevent animals from moving past it to exit the area. This does not include objects such as docks or other pile-supported structures that would not stop animal movement or significantly reflect noise.
21. Metal piles will NOT be installed by impact hammer.
22. Projects within the boundary of the NOAA Florida Keys National Marine Sanctuary require prior approval from the Sanctuary.
23. The Permittee shall use only clean fill material. The fill material shall be upland sources and be free of items such as trash, debris, automotive parts, asphalt, construction materials, concrete block with exposed reinforcement bars, and soils contaminated with any toxic substance, in toxic amounts in accordance with Section 307 of the Clean Water Act.
24. No blasting is authorized.
25. For Projects authorized under this SPGP V in navigable waters of the U.S., the Permittee understands and agrees that, if future operations by the United States require the removal, relocation, or other alteration, of the structures or work herein authorized, or if, in the opinion of the Secretary of the Army or his authorized representative, said structure or work shall cause unreasonable obstruction to the free navigation of the navigable waters, the Permittee will be required, upon due notice from the Corps of Engineers, to remove, relocate, or alter the structural work or obstructions caused thereby, without expense to the United States. No claim shall be made against the United States on account of any such removal or alteration.
26. The SPGP V will be valid for five (5) years from the date of issuance unless suspended or revoked by issuance of a public notice by the District Engineer. The Corps, in conjunction with the Federal resource agencies, will conduct periodic reviews to ensure that continuation of the permit during the five-year authorization period is not contrary to the public interest. If revocation occurs, all future applications for activities covered by the SPGP V will be evaluated by the Corps.
27. If the SPGP V expires or is revoked prior to completion of the authorized work, authorization of activities which have commenced or are under contract to commence in reliance upon the SPGP V will remain in effect provided the activity is completed within twelve (12) months of the date the SPGP V expired or was revoked.
28. The General Conditions attached hereto are made a part of this SPGP V and must be attached to all authorizations processed under this SPGP V.

General Conditions for Federal Authorization for SPGP V

1. The time limit for completing the work authorized ends on July 26, 2021.
2. You must maintain the activity authorized by this permit in good condition and in conformance with the terms and conditions of this permit. You are not relieved of this requirement if you abandon the permitted activity, although you may make a good faith transfer to a third party in compliance with General Condition 4 below. Should you wish to cease to maintain the authorized activity or should you desire to abandon it without a good faith transfer, you must obtain a modification of this permit from this office, which may require restoration of the area.
3. If you discover any previously unknown historic or archeological remains while accomplishing the activity authorized by this permit, you must immediately notify this office of what you have found. We will initiate the Federal and State coordination required to determine if the remains warrant a recovery effort or if the site is eligible for listing in the National Register of Historic Places.
4. If you sell the property associated with this permit, you must obtain the signature of the new owner on the enclosed form and forward a copy of the permit to this office to validate the transfer of this authorization.
5. If a conditioned water quality certification has been issued for your project, you must comply with the conditions specified in the certification as special conditions to this permit.
6. You must allow representatives from this office to inspect the authorized activity at any time deemed necessary to ensure that it is being or has been accomplished in accordance with the terms and conditions of your permit.

Further Information:

1. Limits of this authorization.
 - a. This permit does not obviate the need to obtain other Federal, State, or local authorizations required by law.
 - b. This permit does not grant any property rights or exclusive privileges.
 - c. This permit does not authorize any injury to the property or rights of others.
 - d. This permit does not authorize interference with any existing or proposed Federal projects.
2. Limits of Federal Liability. In issuing this permit, the Federal Government does not assume any liability for the following:
 - a. Damages to the permitted project or uses thereof as a result of other permitted or unpermitted activities or from natural causes.
 - b. Damages to the permitted project or uses thereof as a result of current or future

- activities undertaken by or on behalf of the United States in the public interest.
- c. Damages to persons, property, or to other permitted or unpermitted activities or structures caused by the activity authorized by this permit.
 - d. Design or Construction deficiencies associated with the permitted work.
 - e. Damage claims associated with any future modification, suspension, or revocation of this permit.
3. Reliance on Applicant's Data: The determination of this office that issuance of this permit is not contrary to the public interest was made in reliance on the information you provided.
4. Reevaluation of Permit Decision: This office may reevaluate its decision on this permit at any time the circumstances warrant. Circumstances that could require a reevaluation include, but are not limited to, the following:
- a. You fail to comply with the terms and conditions of this permit.
 - b. The information provided by you in support of your permit application proves to have been false, incomplete, or inaccurate (see 3 above).
 - c. Significant new information surfaces which this office did not consider in reaching the original public interest decision.
5. Such a reevaluation may result in a determination that it is appropriate to use the suspension, modification, and revocation procedures contained in 33 CFR 325.7 or enforcement procedures such as those contained in 33 CFR 326.4 and 326.5. The referenced enforcement procedures provide for the issuance of an administrative order requiring you comply with the terms and conditions of your permit and for the initiation of legal action where appropriate. You will be required to pay for any corrective measures ordered by this office, and if you fail to comply with such directive, this office may in certain situations (such as those specified in 33 CER 209.170) accomplish the corrective measures by contract or otherwise and bill you for the cost.
6. When the structures or work authorized by this permit are still in existence at the time the property is transferred, the terms and conditions of this permit will continue to be binding on the new owner(s) of the property. To validate the transfer of this permit and the associated liabilities associated with compliance with its terms and conditions, have the transferee sign and date the enclosed form.
7. The Permittee understands and agrees that, if future operations by the United States require the removal, relocation, or other alteration, of the structures or work herein authorized, or if, in the opinion of the Secretary of the Army or his authorized representative, said structure or work shall cause unreasonable obstruction to the free navigation of the navigable waters, the Permittee will be required, upon due notice from the U.S. Army Corps of Engineers, to remove, relocate, or alter the structural work or obstructions caused thereby, without expense to the United States. No claim shall be made against the United States on account of any such removal, relocation or alteration.

Department of the Army Permit Transfer for SPGP V

PERMITEE: _____

PERMIT NUMBER: _____ DATE: _____

ADDRESS/LOCATION OF PROJECT:

(Subdivision)

(Lot)

(Block)

When the structures or work authorized by this permit are still in existence at the time the property is transferred, the terms and conditions of this permit will continue to be binding on the new owner(s) of the property. Although the construction period for works authorized by Department of the Army permits is finite, the permit itself, with its limitations, does not expire.

To validate the transfer of this permit and the associated responsibilities associated with compliance with its terms and conditions, have the transferee sign and date below and mail to the U.S. Army Corps of Engineers, Enforcement Branch, Post Office Box 4970, Jacksonville, FL 32232-0019.

(Transferee Signature)

(Date)

(Name Printed)

(Street address)

(Mailing address)

(City, State, Zip Code)

**Construction Guidelines in Florida for Minor Piling-Supported Structures Constructed in
or over Submerged Aquatic Vegetation (SAV), Marsh or Mangrove Habitat
U.S. Army Corps of Engineers/National Marine Fisheries Service
August 2001**

Submerged Aquatic Vegetation:

1. Avoidance. The piling-supported structure shall be aligned so as to minimize the size of the footprint over SAV beds.
2. The height of piling-supported structure shall be a minimum of 5 feet above MHW/OHW as measured from the top surface of the decking.
3. The width of the piling-supported structure is limited to a maximum of 4 feet. A turnaround area is allowed for piling-supported structures greater than 200 feet in length. The turnaround is limited to a section of the piling-supported structure no more than 10 feet in length and no more than 6 feet in width. The turnaround shall be located at the midpoint of the piling-supported structure.
4. Over-SAV bed portions of the piling-supported structure shall be oriented in a north-south orientation to the maximum extent that is practicable.
 5. a. If possible, terminal platforms shall be placed in deep water, waterward of SAV beds or in an area devoid of SAV beds.
 - b. If a terminal platform is placed over SAV areas and constructed of grated decking, the total size of the platform shall be limited to 160 square feet. The grated deck material shall conform to the specifications stipulated below. The configuration of the platform shall be a maximum of 8 feet by 20 feet. A minimum of 5 feet by 20 feet shall conform to the 5-foot height requirement; a 3 feet by 20 feet section may be placed 3 feet above MHW to facilitate boat access. The long axis of the platform should be aligned in a north-south direction to the maximum extent that is practicable.
 - c. If the terminal platform is placed over SAV areas and constructed of planks, the total size of the platform shall be limited to 120 square feet. The configuration of the platform shall be a maximum of 6 feet by 20 feet of which a minimum 4-foot wide by 20-foot long section shall conform to the 5-foot height requirement. A section may be placed 3 feet above MHW to facilitate boat access. The 3 feet above MHW section shall be cantilevered. The long axis of the platform should be aligned in a north-south direction to the maximum extent that is practicable. If the 3 feet above MHW section is constructed with grating material, it may be 3 feet wide.
6. One uncovered boat lift area is allowed. A narrow catwalk (2 feet wide if planks are used, 3 feet wide if grating is used) may be added to facilitate boat maintenance along the outboard side of the boat lift and a 4-foot wide walkway may be added along the stern end of the boat lift, provided all such walkways are elevated 5 feet above MHW. The catwalk shall be cantilevered from the outboard mooring pilings (spaced no closer than 10 feet apart).
7. Pilings shall be installed in a manner which will not result in the formation of sedimentary deposits ("donuts" or "halos") around the newly installed pilings. Pile driving is the preferred method of installation, but jetting with a low pressure pump may be used.
8. The spacing of pilings through SAV beds shall be a minimum of 10 feet on center.
9. The gaps between deckboards shall be a minimum of ½ inch.

Marsh:

Grid Specifications and Suppliers Section modified in October 2002 to add an additional vendor of materials.

February 2003 - Manufacturer name changed from ChemGrate to FiberGrate

May 2003 - The terms dock and pier were removed and replaced by the term piling-supported structure, to clarify our intent.

March 2008 - Added requirement for 43% open space in grids; added additional manufacturer of grating. -

1. The piling-supported structure shall be aligned so as to have the smallest over-marsh footprint as practicable.
2. The over-marsh portion of the piling-supported shall be elevated to at least 4 feet above the marsh floor.
3. The width of the piling-supported is limited to a maximum of 4 feet. Any exceptions to the width must be accompanied by an equal increase in height requirement.

Mangroves.

1. The width of the piling-supported structure is limited to a maximum of 4 feet.
2. Mangrove clearing is restricted to the width of the piling-supported structure.
3. The location and alignment of the piling-supported structure should be through the narrowest area of the mangrove fringe.

Grid Specifications and Suppliers

The following information does not constitute a U.S. Army Corps of Engineers endorsement or advertisement for any particular provider and is provided only as an example for those interested in obtaining these materials for piling-supported structure construction. Light-transmitting materials are made of various materials shaped in the form of grids, grates, lattices, etc., to allow the passage of light through the open spaces. All light-transmitting materials used in construction for minor piling-supported structures shall have a minimum of forty-three (43) percent open space.

A type of fiberglass grate panel is manufactured by SeaSafe (Lafayette, LA; phone: 1-800-326-8842) and FiberGrate (1-800-527-4043). A type of plastic grating is manufactured by ThruFlow Interlocking Panels (1-888-478-3569). Plastic grate panels are also distributed by Southern Pine Lumber Company (Stuart, FL; 772-692-2300). Panels are available in a variety of sizes and thicknesses. For safety, the grate should contain an anti-slip texture which is integrally molded into the top surface. The manufacturer or local distributor should be consulted to ensure that the load-bearing capacity of the selected product is sufficient to support the intended purpose. Contact the manufacturer(s) for product specifications and a list of regional distributors.

Grid Specifications and Suppliers Section modified in October 2002 to add an additional vendor of materials.

February 2003 - Manufacturer name changed from ChemGrate to FiberGrate

May 2003 - The terms dock and pier were removed and replaced by the term piling-supported structure, to clarify our intent.

March 2008 - Added requirement for 43% open space in grids; added additional manufacturer of grating. -

DUNCAN GREER C:\USERS\GREER\WORK\POQUITO\CAD\2017-05-31_POQUITO_PERMITS\DWG_1.DWG 6/15/2017 8:52:22 AM

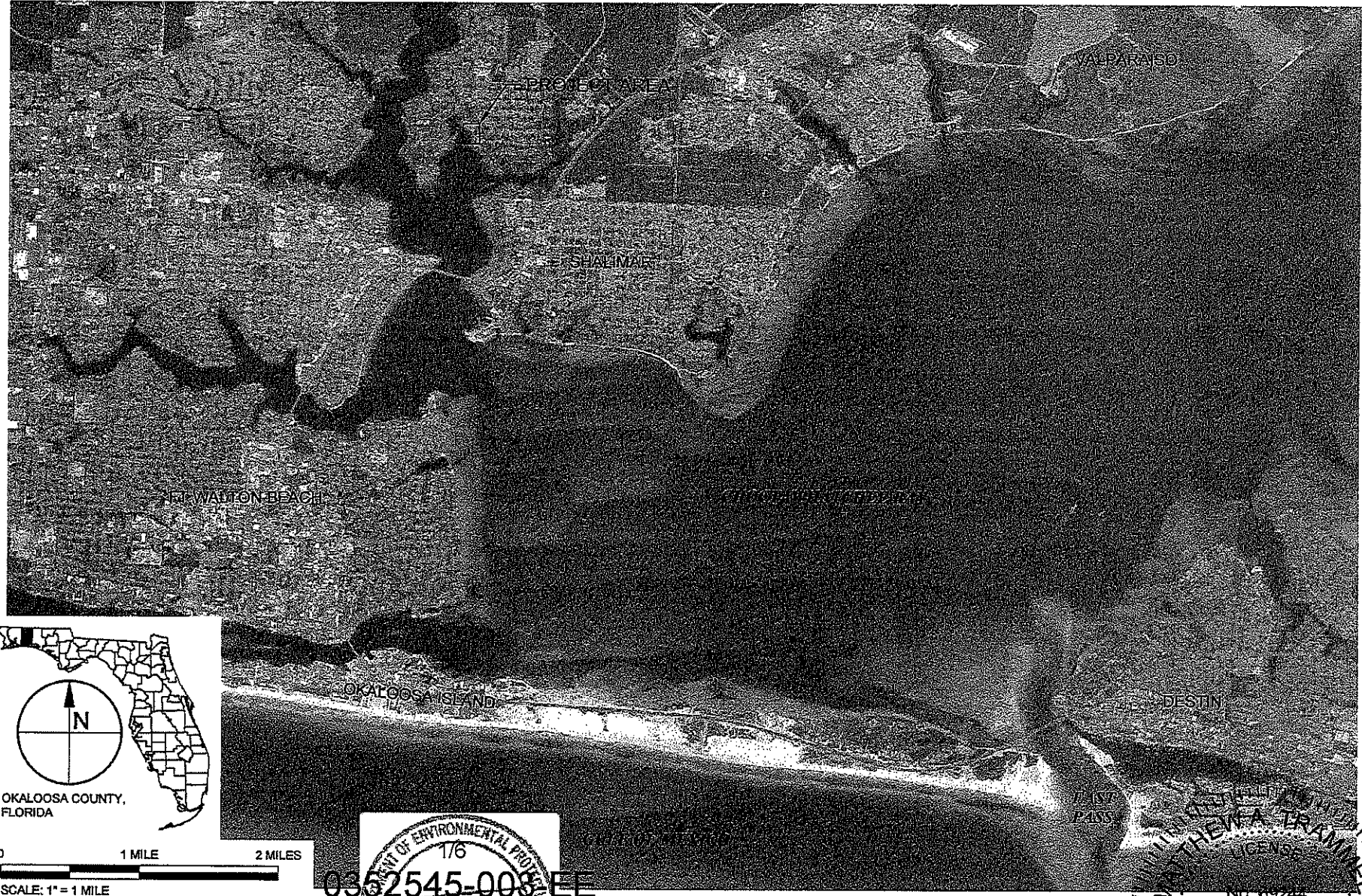

OKALOOSA COUNTY, FLORIDA

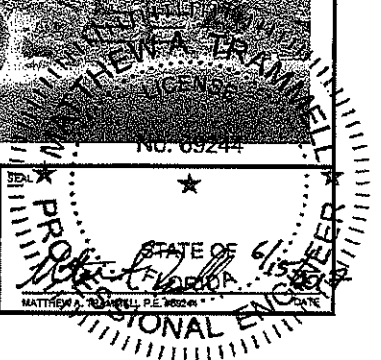
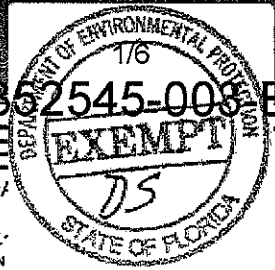

TAYLOR ENGINE
1221 AIRPORT RD/
SUITE 210
DESTIN, FL 32547
CERTIFICATE OF AUTHORIZATION

FIGURE 1 - LOCATION MAP
POQUITO PARK DOCK EXTENSION
LONGWOOD / POQUITO BAYOU PARK
OKALOOSA COUNTY, FL

PROJECT	C2017-016
DRAWN BY	DG
SHEET	1 of 6
DATE	MAY 2017

PRELIMINARY DRAWINGS: THESE DRAWINGS ARE NOT IN FINAL FORM, BUT ARE BEING TRANSMITTED FOR AGENCY REVIEW.

GENERAL NOTES:

1. DRAWING REFERENCES THE FLORIDA STATE PLANE NORTH, NORTH AMERICAN DATUM OF 1983 (NAD83)
2. ALL ELEVATIONS REFERENCE THE 1988 NORTH AMERICAN VERTICAL DATUM (NAVD88). ELEVATIONS IN FEET UNLESS NOTED OTHERWISE
3. AERIAL IMAGERY OBTAINED FROM GOOGLE EARTH (2013). AERIAL IMAGERY DISPLAYED HEREON FOR INFORMATIONAL PURPOSES ONLY. NO PHOTOGRAPHIC ACCURACY IS IMPLIED BY THESE MAPS.
4. BATHYMETRIC, TOPOGRAPHIC, PROPERTY BOUNDARY, AND MEAN HIGH WATER SURVEY PERFORMED BY OKALOOSA COUNTY ENGINEERING DEPARTMENT, JANUARY 11, 2017.
5. CONSTRUCTION SHALL NOT VIOLATE STATE WATER QUALITY STANDARDS.
6. NO LIVEBOARDS, FUELING FACILITIES, OR SEWAGE PUMPOUTS ARE PROPOSED.
7. ALL MOORING IS TEMPORARY/TRANSIENT AND INTENDED FOR BOAT RAMP STAGING. NO PERMANENT SLIPS PROPOSED.
8. PILE EMBEDMENT AND DIMENSIONS WILL BE DETERMINED DURING FINAL DESIGN.
9. DOCK PILINGS WILL BE WRAPPED OR OTHERWISE MADE FROM NON-LEACHING MATERIALS.
10. THE LOCATION OF TURBIDITY CURTAINS SHOWN ON THESE DRAWINGS IS FOR INFORMATIONAL PURPOSES ONLY. TURBIDITY CURTAINS SHALL BE LOCATED AND REPOSITIONED BY THE CONTRACTOR USING BEST MANAGEMENT PRACTICES TO ASSURE WATER QUALITY STANDARDS ARE MAINTAINED THROUGHOUT CONSTRUCTION.

PROPOSED DOCK PLAN:

1. TOTAL NUMBER OF SLIPS: 0
2. TOTAL FIXED TIMBER DOCK AREA: 998 S.F.
 - 2.1. EXISTING: 322 S.F.
 - 2.2. DEMOLISHED: 54 S.F.
 - 2.3. PROPOSED: 730 S.F.
3. PROPOSED TRANSIENT MOORING AREA: 120 L.F.

D:\MICHAEL GREER\ C:\USERS\MICHAEL GREER\DESKTOP\PROJECTS\CAD\DWG\017-05-2A_POQUITO_PENITENTIA_1.DWG 6/16/2017 9:50:20 AM

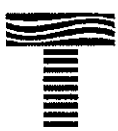

TAYLOR ENGINEERING

1221 AIRPORT ROAD
SUITE 210
DESTIN, FL 32541
CERTIFICATE OF AUTHORIZATION:

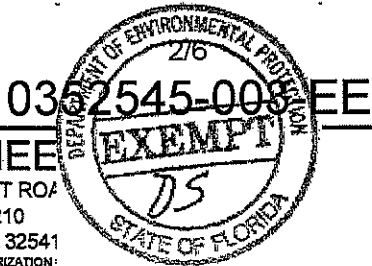
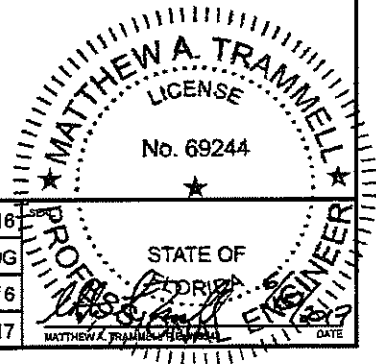
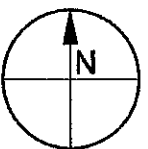
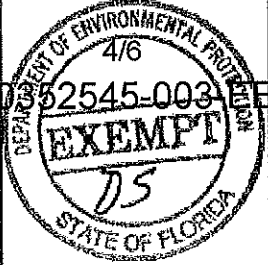
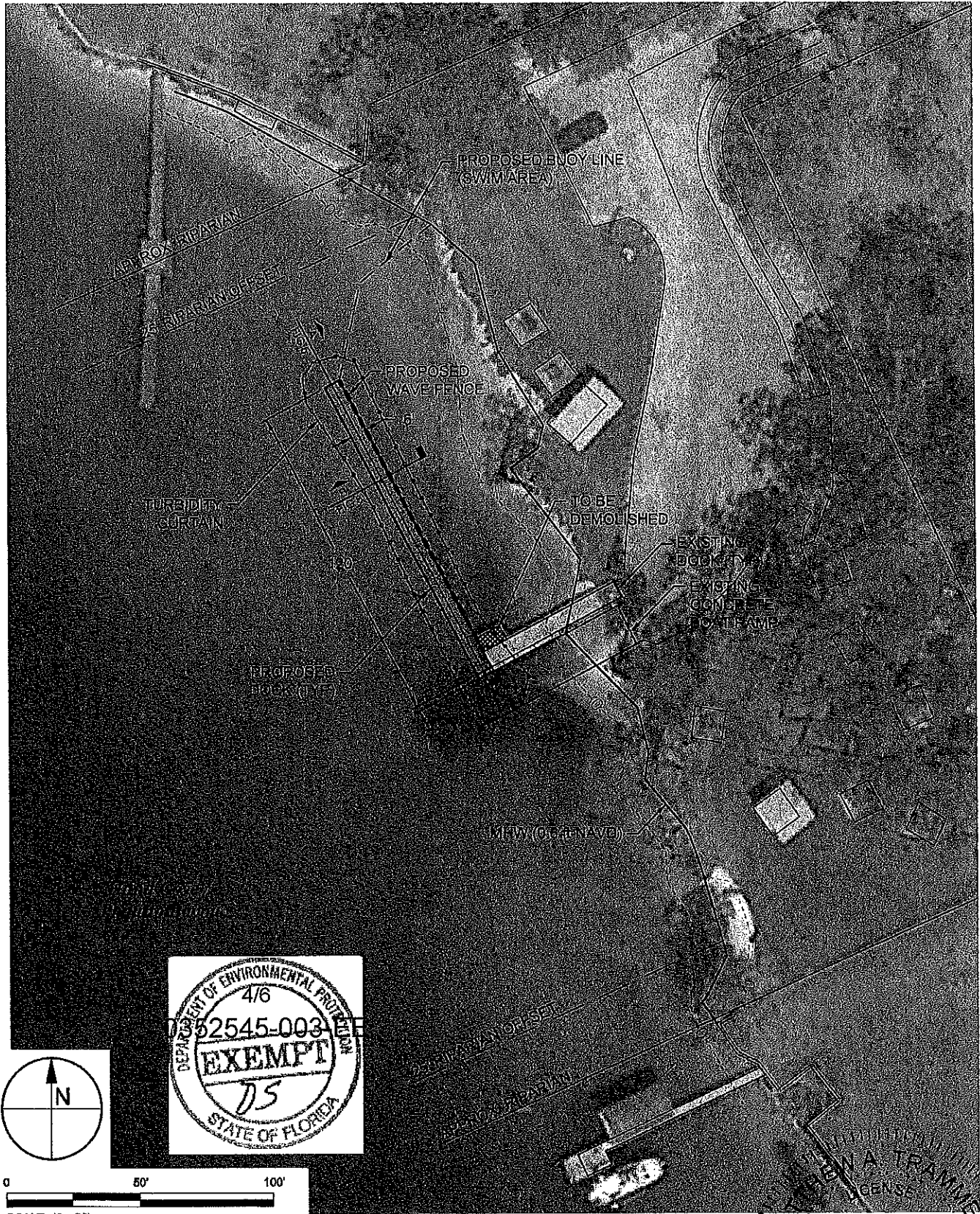

FIGURE 2 - NOTES
POQUITO PARK DOCK EXTENSION
LONGWOOD / POQUITO BAYOU PARK
OKALOOSA COUNTY, FL

PROJECT	C2017-016
DRAWN BY	DG
SHEET	2 of 6
DATE	MAY 2017



D:\NCS\GREER_C\BIBS\BIBS\BIBS\POQUITO\017-06-31_POQUITO_PERMITS\DWG_1.DWG 6/15/2017 9:52:27 AM



0 50' 100'
SCALE: 1" = 50'

 **TAYLOR ENGINEERING INC.**
1221 AIRPORT ROAD
SUITE 210
DESTIN, FL 32541
CERTIFICATE OF AUTHORIZATION # 4815

**FIGURE 4 - PROPOSED CONDITIONS
POQUITO PARK DOCK EXTENSION
LONGWOOD / POQUITO BAYOU PARK
OKALOOSA COUNTY, FL**

PROJECT C2017-016	DRAWN BY DG	SHEET 4 of 6	DATE MAY 2017
----------------------	----------------	-----------------	------------------

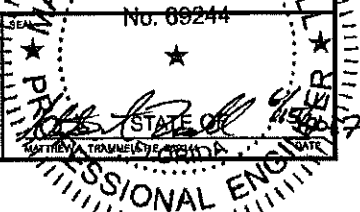

PRELIMINARY DRAWINGS: THESE DRAWINGS ARE NOT IN FINAL FORM, BUT ARE BEING TRANSMITTED FOR AGENCY REVIEW.

D:\WORK\GREEN_C\USER\ENGINEERING\PROJECTS\C2017-016\2017-05-24_POQUITO_PARK\DWG_P515112.DWG 6/10/2017 8:03:29 AM

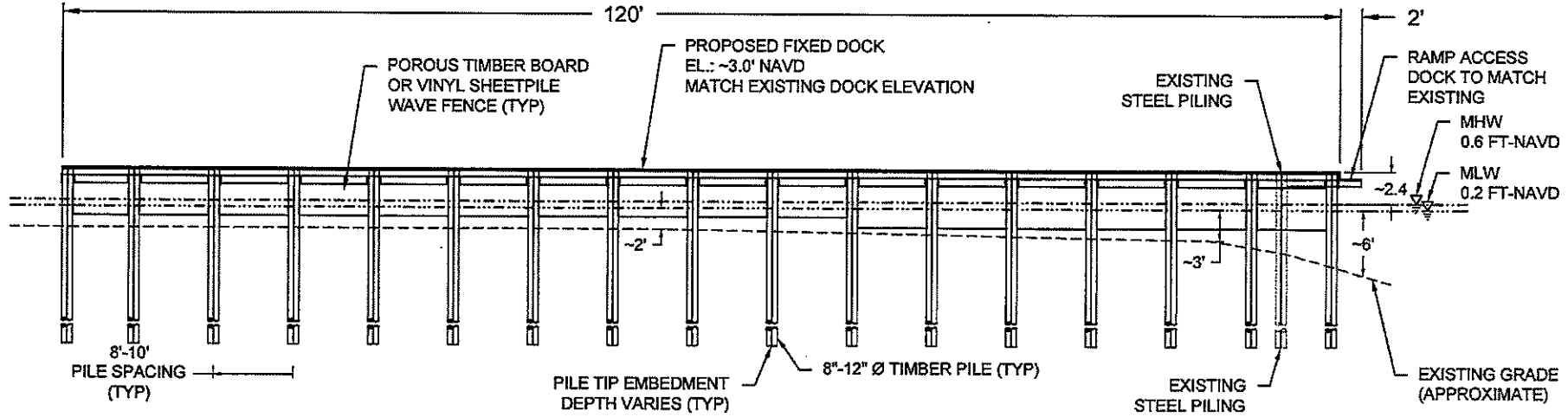

A
FIG. 4 **DOCK SECTION 1**
 SCALE: 1" = 15'

0362545-008
 TAYLOR ENGINEERING
 1221 AIRPORT ROAD
 SUITE 210
 DESTIN, FL 32541
 CERTIFICATE OF AUTHORIZATION: 5/6

FIGURE 5 - DOCK SECTION 1
 POQUITO PARK DOCK EXTENSION
 LONGWOOD / POQUITO BAYOU PARK
 OKALOOSA COUNTY, FL

PROJECT	C2017-016
DRAWN BY	DG
SHEET	5 of 6
DATE	MAY 2017

MATTHEW A. TRAMMELL
 LICENSE
 No. 69244
 PROFESSIONAL ENGINEER
 STATE OF FLORIDA

D:\CADD\GREER_0\UBER\8\DOCK\RECENT\POQUITO\POQUITO\DOCK\2017-05-24_POQUITO_PERMITS\DWG_1.DWG 6/15/2017 8:35:30 AM

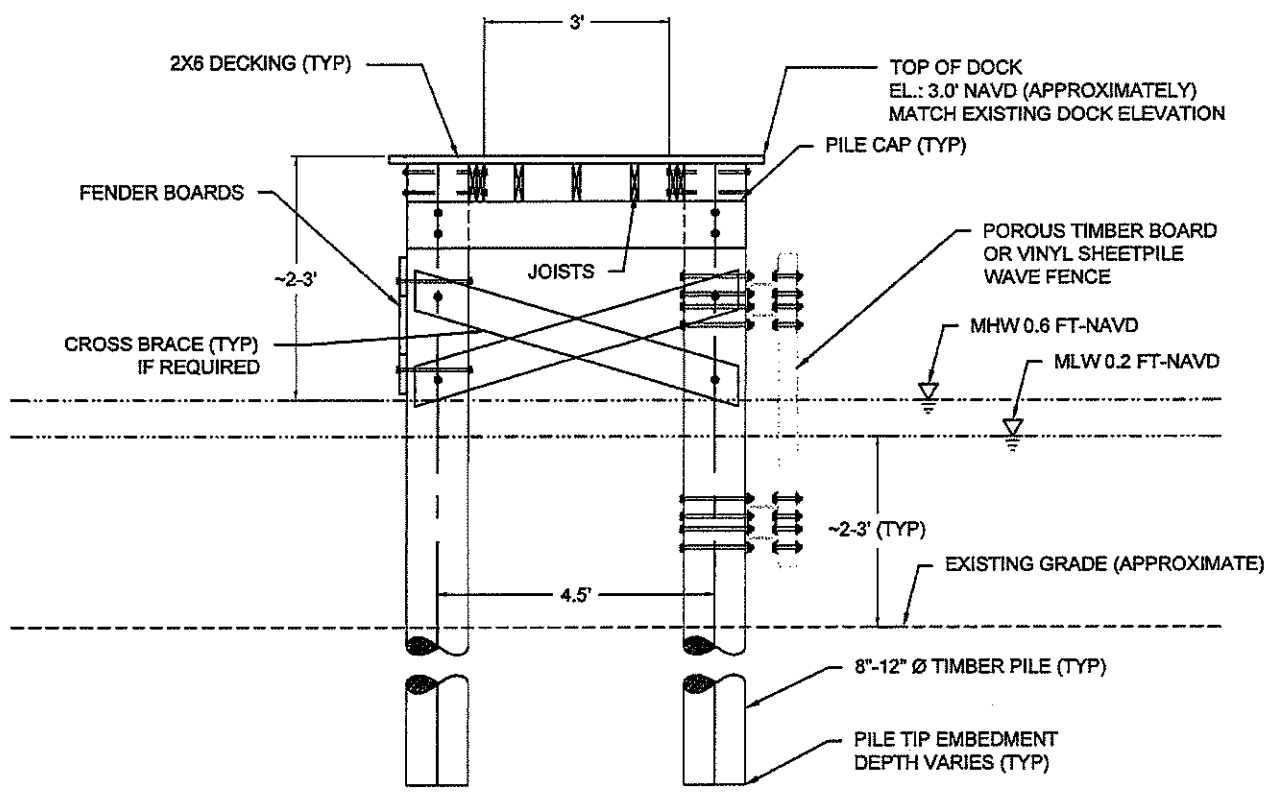

8 DOCK SECTION 2
FIG. 4 SCALE: 1" = 3'

0302545-008 EE

6/6

EXEMPT

75

DEPARTMENT OF ENVIRONMENTAL PROTECTION
STATE OF FLORIDA

TAYLOR ENGINE
1221 AIRPORT ROAD
SUITE 210
DESTIN, FL 32541
CERTIFICATE OF AUTHORIZATION:

FIGURE 6 - DOCK SECTION 2
POQUITO PARK DOCK EXTENSION
LONGWOOD / POQUITO BAYOU PARK
OKALOOSA COUNTY, FL

PROJECT	C2017-016
DRAWN BY	DG
SHEET	6 of 6
DATE	MAY 2017

MATTHEW A. TRAMMELL
LICENSE
No. 69244

STATE OF FLORIDA
PROFESSIONAL ENGINEER

MAY 2017

PRELIMINARY DRAWINGS: THESE DRAWINGS ARE NOT IN FINAL FORM, BUT ARE BEING TRANSMITTED FOR AGENCY REVIEW.

ADDENDUM NO. 1

TO: ALL BIDDERS
PROJECT: ITB PW 49-20 – Longwood / Poquito Bayou Park
Dock Extension
BID TIME AND DATE: 3:00 PM LOCAL TIME, July 22, 2020 (NO CHANGE)

July 06, 2020

The following items are hereby incorporated into the project manual, procurement documents, contract documents, plans and specifications:

ITEM NO. 1

– QUESTIONS RECEIVED POST ADVERTISEMENT

Question 1 – **“Can WearDeck™ reinforced composite lumber be used as the decking for the Longwood / Poquito Bayou Park Dock Extension project?”**

Answer: Bids should be based on decking as specified in the construction drawings. Following Contract award, the County may consider decking material alternatives proposed by the Contractor.

Question 2 – **“Please provide documents that reference the Subsurface and Physical Conditions relating to ITB PW 49-20, Longwood/ Poquito Bayou Park Dock Extension.”**

Answer: There are no reports of subsurface or physical conditions. Please refer to Article 4, paragraph 4.01, subparagraphs A and B of the Instructions to Bidders and Article 5, paragraph 5.03, subparagraph A of the Supplementary Conditions.

END OF QUESTIONS

RECEIPT OF THIS ADDENDUM SHALL BE ACKNOWLEDGED BY WRITING THIS ADDENDUM NUMBER AND DATE IN THE SPACE PROVIDED ON DOCUMENT 00410-7, 'ADDENDUM ACKNOWLEDGEMENT - ATTACHMENT A.'

/s/ Roy Petrey
Roy Petrey, P.E.
Project Manager

ADDENDUM NO. 2

TO: ALL BIDDERS
PROJECT: ITB PW 49-20 – Longwood / Poquito Bayou Park
Dock Extension
BID TIME AND DATE: 3:00 PM LOCAL TIME, July 22, 2020 (NO CHANGE)

July 09, 2020

The following items are hereby incorporated into the project manual, procurement documents, contract documents, plans and specifications:

ITEM NO. 1

– QUESTIONS RECEIVED POST ADVERTISEMENT

Question 1 – **“Drawing C-5 Timber Dock Elevation and C-7 shows the pile cap as 3"x10" treated timbers. Drawing C-6 Typical Section Detail "A" calls for 3" x 8" treated timbers. Which is correct?”**

Answer: All pile caps shall be 3x10. The final drawings will correct the callout on the referenced detail.

Question 2 – **“For the safety of the general public and construction crews, will the County consider closing the boat ramp during construction?”**

Answer: The contractor shall maintain access to boat ramp and shoreline areas for the general public to the greatest extent practical throughout construction operations; however, the contractor shall exclude the public from work areas as necessary to ensure public safety. Please refer to Specifications within the drawings; Limits of Construction, Staging and Access Areas.

END OF QUESTIONS

RECEIPT OF THIS ADDENDUM SHALL BE ACKNOWLEDGED BY WRITING THIS ADDENDUM NUMBER AND DATE IN THE SPACE PROVIDED ON DOCUMENT 00410-7, 'ADDENDUM ACKNOWLEDGEMENT - ATTACHMENT A.'

/s/ Roy Petrey
Roy Petrey, P.E.
Project Manager

ITB PW 49-20

Longwood/Poquito Bayou Park Dock Extensions

Bid Sheet

July 22, 2020 @ 3:00 P.M.

Company Name: Decks N Such Marine, Inc.

Contractors Bonds and Insurance: \$ 6000⁰⁰

Mobilization and Demobilization: \$ 5720⁰⁰

Decking and Rub Rail Replacement: \$ 6673⁰⁰

Dock and Wave Fence: \$ 94,600⁰²

Total Base Bid: \$ 112,993⁰²

Company Name: Floridian Const

Contractors Bonds and Insurance: \$ 10,000⁰⁰

Mobilization and Demobilization: \$ 15,000⁰⁰

Decking and Rub Rail Replacement: \$ 24000⁰⁰

Dock and Wave Fence: \$ 165,981⁰⁰

Total Base Bid: \$ 214,981⁰⁰

Company Name: Worley Const

Contractors Bonds and Insurance: \$12,000⁰⁰

Mobilization and Demobilization: \$128,967⁰⁰

Decking and Rub Rail Replacement: \$128,967⁰⁰

Dock and Wave Fence: \$129,076⁰⁰

Total Base Bid: \$399,010⁰⁰

Company Name: Hughes + Co, LLC

Contractors Bonds and Insurance: \$8,400⁰⁰

Mobilization and Demobilization: \$15,000⁰⁰

Decking and Rub Rail Replacement: \$10,500⁰⁰

Dock and Wave Fence: \$192,760⁰⁰

Total Base Bid: \$226,660⁰⁰

Company Name: RJ Gorman Marine

Contractors Bonds and Insurance: \$9,732⁶⁶

Mobilization and Demobilization: \$26,930⁹¹

Decking and Rub Rail Replacement: \$16,985⁴⁸

Dock and Wave Fence: \$160,217⁹¹

Total Base Bid: \$213,866⁹⁶