

STANDARD FORM CONSTRUCTION BID AGREEMENT

THIS AGREEMENT is dated as of the 14th day of April in the year 2022 by and between Santa Rosa County, a political subdivision of the state of Florida (“County”) and Complete Site Source (“Contractor”).

County and Contractor, in consideration of the mutual covenants hereinafter set forth, agree as follows:

Article 1. WORK.

Contractor shall complete all Work as specified or indicated in the Contract Documents. The Work is generally described as follows:

CONSTRUCT THE “NAVARRE BEACH PRIVATE AIDS TO NAVIGATION.”

Article 2. ENGINEER.

The Project has been designed by:

BASKERVILLE-DONOVAN, INC

Who is hereinafter called Engineer and who is to act as County's representative, assume all duties and responsibilities and have the rights and authority assigned to Engineer in the Contract Documents in connection with completion of the Work in accordance with the Contract Documents.

Article 3. CONTRACT TIMES.

3.1 The Work will be substantially completed within 90 calendar days after the date when the Contract Times commence to run, and completed and ready for final payment within 120 calendar days after the date when the Contract Times commence to run.

3.2 Liquidated Damages. County and Contractor recognize that time is of the essence of this Agreement and that County will suffer financial loss if the Work is not completed within the times specified in paragraph 3.1 above, plus any extensions thereof allowed by the County. They also recognize the delays, expense and difficulties involved in proving the actual loss suffered by County if the Work is not completed on time. Accordingly, instead of requiring of such proof, County and Contractor agree that as liquidated damages for delay (but not as a penalty) Contractor shall pay County the amount specified in Paragraph 3.3. for each day that expires after the time specified in paragraph 3.1 for Substantial Completion until the Work is substantially complete. After Substantial Completion, if Contractor shall neglect, refuse, or fail to complete the remaining Work within the time specified in paragraph 3.1 for completion and readiness for final payment or any proper extension thereof granted by County, Contractor shall pay County the amount specified in Paragraph 3.3. for each day that expires after the time specified in paragraph 3.1 for completion and readiness for final payment. The Contractor hereby expressly waives and relinquishes any right which it may have to seek to characterize the liquidated damages as a penalty, which the parties agree represents a fair and reasonable estimate of the County's actual damages at the time of contracting if the Contractor fails to substantially complete the Work in a timely manner.

3.3 Liquidated Damages are based upon the original contract amount, as established by Santa Rosa County. Liquidated damages, based upon the original contract amount of \$98,950.00, will be Eight Hundred Eighty-Two Dollars (\$882.00) per calendar day.

LIQUIDATED DAMAGES SCHEDULE

Phase	Begin Date	Consecutive Calendar Days to Complete	Liquidated Damages
1	Notice to Proceed	10	\$882.00 as Referenced on ITB 22-017
Entire Project		90	\$882.00 as Referenced on ITB 22-017

Article 4. CONTRACT PRICE.

County shall pay Contractor for completion of the Work in accordance with the Contract Documents an amount in current funds equal to the sum of the established unit price for each separately identified item of Unit Price Work times the estimated quantity of that item as indicated in the Bid Schedule submitted in the Bid Form. The cost of this project is \$ 98,950.00 as per the attached Contractor bid.

Estimated quantities are not guaranteed, and determinations of actual quantities and classification are to be made by Engineer.

Article 5. PAYMENT PROCEDURES

Contractor shall submit Application for Payment in accordance with Contract. Applications for Payment will be processed by Engineer as provided in the contract.

5.1 Progress Payments; Retainage. County shall make progress payments on account of the Contract Price on the basis of Contractor's Applications for Payment as recommended by Engineer, on or about the fifteenth (15th) day of each month during construction as provided in paragraph 5.1.1. All such payments will be measured based on the number of units completed. Payments to the Contractor shall in no way imply approval or acceptance of Contractor's work.

5.1.1 Contractor may be paid 95 % of Work completed (with the balance being retainage), less the aggregate of payments previously made and less such amounts as Engineer shall determine, or County may withhold. Contractor may be paid 95 % (with the balance being retainage) of materials and equipment not incorporated in the Work (but delivered, suitably stored and accompanied by documentation satisfactory to County).

5.1.2 Retainage requirements may be changed to reflect a proposed change to state regulatory statutes.

5.2 Final Payment. Upon final completion and acceptance of the Work, County shall pay the remainder of the Contract Price as recommended by Engineer.

5.2.1 Contractor's acceptance of final payment shall constitute a full waiver of any and all claims by Contractor against the County arising out of this Agreement or otherwise relating to the Project, except those previously made in writing and identified by Contractor as unsettled at the time of the final Application for Payment. Neither the acceptance of the Work nor payment by the County shall be deemed to be a waiver of the County's right to enforce any obligations of the Contractor hereunder or to the recovery of damages for defective Work not discovered by the Engineer or the County at the time of final inspection.

5.3 Payments Withheld

- 5.3.1 The Engineer or the County may decline to approve any Applications for Payment, or portions thereof, because of subsequently discovered evidence or subsequent inspections. The Engineer or the County may nullify the whole or any part of any inspections. The Engineer or the County may nullify the whole or any part of any approval for payment previously issued and the County may withhold any payments otherwise due Contractor under this Agreement or any other agreement between the County and the Contractor, to such extent as may be necessary in the County's opinion to protect it from loss because of:
- 5.3.1.1 Defective Work not remedied;
 - 5.3.1.2 Third party claims filed or reasonable evidence indicating probable filing of such claims;
 - 5.3.1.3 Failure of Contractor to make payment properly to subcontractors or for labor, materials or equipment;
 - 5.3.1.4 Reasonable doubt that the Work can be completed for the unpaid balance of the Contract Amount;
 - 5.3.1.5 Reasonable indication that the Work will not be completed within the Contract Time;
 - 5.3.1.6 Unsatisfactory prosecution of the Work by the Contractor;
 - 5.3.1.7 Failure to provide accurate and current "As-Builts"; or
 - 5.3.1.8 Any other material breach of the Contract Documents.
- 5.3.2 If these conditions in Subsection 5.3.1 are not remedied or removed, the County may after three (3) days written notice, rectify the same at Contractor's expense. The County also may offset against any sums due Contractor the amount of any liquidated or unliquidated obligations of Contractor to the County, whether relating to or arising out of his Agreement or any other agreement between Contractor and the County.

Article 6. CONTRACTOR'S REPRESENTATIONS.

In order to induce County to enter into this Agreement Contractor makes the following representations:

- 6.1 Contractor has examined and carefully studied the Contract Documents (including the Addenda listed in Article 7) and the other related data identified in the Project Documents including "technical data."
- 6.2 Contractor has visited the site and become familiar with and is satisfied as to the general, local, and site conditions that may affect cost, progress, performance or furnishing of the Work.
- 6.3 Contractor is familiar with and is satisfied as to all federal, state, and local Laws and Regulations that may affect cost, progress, performance and furnishing of the Work.
- 6.4 Contractor has carefully studied all reports of explorations and tests of subsurface conditions at or contiguous to site and all drawings of physical conditions in or relating to existing surface or subsurface structures at or contiguous to the site (except Underground Facilities) which have been identified in the Bid documents. Contractor acknowledges that such reports and drawings are not Contract Documents and may not be complete for Contractor's purposes. Contractor acknowledges that County and Engineer do not assume responsibility for the accuracy or completeness of information and data shown, indicated in the Contract Documents with respect to Underground Facilities at, or contiguous to the site. Contractor has obtained and carefully studied (or assumes responsibility for having done so) all such additional supplementary examinations, investigations, explorations, tests, studies, and data concerning conditions (surface, subsurface, and Underground Facilities) at or contiguous to the site or otherwise which may affect

cost, progress, performance, or furnishing of the Work or which relate to any aspect of the means, methods, techniques, sequences, and procedures of construction to be employed by Contractor and safety precautions, and programs incident thereto. Contractor does not consider that any additional examinations, investigations, explorations, tests, studies, or data are necessary for the performance and furnishing of the Work at the Contract Price, within the Contract Times and in accordance with the other terms and conditions of the Contract Documents.

6.5 Contractor is aware of the general nature of work to be performed by County and others at the site that relates to the Work as indicated in the Contract Documents.

6.6. Contractor has correlated the information known to Contractor, information and observation obtained from visits to the site, reports, and drawings identified in the Contract Documents and all additional examinations, investigations, explorations, tests, studies, and data with the Contract Documents.

6.7. Contractor has given Engineer written notice of all conflicts, errors, ambiguities or discrepancies that Contractor has discovered in the Contract Documents and the written resolution thereof by Engineer is acceptable to Contractor, and the Contract Documents are generally sufficient to indicate and convey understanding of all terms and conditions for performance and furnishing of the Work.

Article 7. CONTRACT DOCUMENTS

The Contract Documents that comprise the entire agreement between County and Contractor concerning the Work consist of the following:

- 7.1 This Agreement
- 7.2 Exhibit A- Scope of Work and Contractor's Bid
- 7.3 Exhibit B- Insurance Requirements
- 7.4 Exhibit C- Civil Rights Clauses
- 7.5 Exhibit D- Scrutinized Contractors Certificate
- 7.6 Any other documents necessary to clarify and memorialize the agreement between Contractor and County.

Article 8. PUBLIC RECORDS

Any record created by either party in accordance with this Contract shall be retained and maintained in accordance with the public records law, Florida Statutes, Chapter 119.

IF THE CONTRACTOR HAS QUESTIONS REGARDING THE APPLICATION OF CHAPTER 119, FLORIDA STATUTES, TO THE CONTRACTOR'S DUTY TO PROVIDE PUBLIC RECORDS RELATING TO THIS CONTRACT, CONTACT THE CUSTODIAN OF PUBLIC RECORDS, AT (850) 963-1925, wandap@santarosa.fl.gov, 6945 Caroline Street, Milton, FL 32570.

Contractor must comply with the public records laws, Florida Statute Chapter 119. Specifically, Contractor must:

- 8.1 Keep and maintain public records required by the County to perform the service.
- 8.2 Upon request from the County's custodian of public records, provide the County with a copy of the requested records or allow the records to be inspected or copied within a reasonable time at a cost that does not exceed the cost provided in Chapter 119 Florida Statutes or as otherwise provided by law.
- 8.3 Ensure that public records that are exempt or confidential and exempt from public records disclosure requirements are not disclosed except as authorized by law for the duration of the contract term and following completion of the contract if the consultant does not transfer the records to the County.
- 8.4 Upon completion of the contract, transfer, at no cost, to the County all public records in possession of the contractor or keep and maintain public records required by the County to perform the service. If the contractor transfers all public records to the public agency upon completion of the contract, the consultant shall destroy any duplicate public records that are exempt or confidential and exempt from public records disclosure requirements. If the consultant keeps and maintains public records upon completion of the contract, the contractor shall meet all applicable requirements for retaining the public records. All records stored electronically must be provided to the public agency, upon the request from the public agency's custodian of public records, in a format that is compatible with the information technology systems of the public agency.

Article 9. AUDIT

The County and/or its designee shall have the right from time to time at its sole expense to audit the compliance by the Contractor with the terms, conditions, obligations, limitations, restrictions, and requirements of this Contract and such right shall extend for a period of three (3) years after termination of this Contract.

Article 10. TERMINATION FOR CONVENIENCE

County may at any time and for any reason terminate Contractor's services and work at County's convenience. Upon receipt of such notice, Contractor shall, unless the notice directs otherwise, immediately discontinue the work and placing of orders for materials, facilities and supplies in connection with the performance of this Agreement.

Upon such termination, Contractor shall be entitled to payment only as follows: (1) the actual cost of the work completed in conformity with this Agreement; plus, (2) such other costs actually incurred by Contractor as are permitted by the prime contract and approved by County; (3) plus five percent (5%) of the cost of the work referred to in subparagraph (1) above for overhead and profit. There shall be deducted from such sums as provided in this subparagraph the amount of any payments made to Contractor prior to the date of the termination of this Agreement. Contractor shall not be entitled to any claim or claim of lien against County for any additional compensation or damages in the event of such termination and payment. Further, County may terminate this contract immediately for failure of contractor to comply with Chapter 119, Florida Statutes.

Article 11. VIOLATIONS OF CHAPTER 119 FLORIDA STATUTES

The County reserves the right to terminate this agreement immediately for failure of Contractor to adhere to the requirements of Florida Statutes Chapter 119.

Article 12. MISCELLANEOUS.

- 12.1 Terms used in this Agreement which are defined in the Bid documents.
- 12.2 No assignment by a Party of any rights under or interests in the Contract Documents will be binding on another Party without the written consent of the Party sought to be bound; and, specifically but without limitation, moneys that may become due and moneys that are due may not be assigned without such consent (except to the extent that the effect of this restriction may be limited by law), and unless specifically stated to the contrary in any written consent to an assignment no assignment will release or discharge the assignor from any duty or responsibility under the Contract Documents.
- 12.3 County and Contractor each binds itself, its partners, successors, assigns and legal representatives to the other Party, its partners, successors, assigns and legal representatives in respect to all covenants, agreements, and obligations contained in the Contract Documents.
- 12.4 Any provisions or part of the Contract Documents held to be void or unenforceable under any Law or Regulation shall be deemed stricken, and all remaining provisions shall continue to be valid and binding upon County and Contractor, who agree that the Contract Documents shall be reformed to replace such stricken provision or part thereof with a valid and enforceable provision that comes as close as possible to expressing the intention of the stricken provision
- 12.5 All documents prepared by the Contractor pursuant to this Agreement and related Services to this Agreement are intended and represented for the ownership of the County only. Any other use by Contractor or other parties shall be approved in writing by the County. If requested, Contractor shall deliver the documents to the County within fifteen (15) calendar days.

Article 13. GOVERNING LAW, VENUE AND WAIVER OF JURY TRIAL.

This Agreement shall be interpreted and construed in accordance with and governed by the laws of the State of Florida. All parties agree and accept that jurisdiction of any dispute or controversy arising out of this Agreement, and any action involving the enforcement or interpretation of any rights hereunder shall be brought exclusively in the 1st Judicial Circuit in and for Santa Rosa County, Florida, and venue for litigation arising out of this Agreement shall be exclusively in such state courts, forsaking any other jurisdiction which either party may claim by virtue of its residency or other jurisdictional device. In the event it becomes necessary for the County to file a lawsuit to enforce any term or provision under this Agreement, then the County shall be entitled to its costs and attorney's fees at the pretrial, trial and appellate levels. BY ENTERING INTO THIS AGREEMENT, CONTRACTOR AND COUNTY HEREBY EXPRESSLY WAIVE ANY RIGHTS EITHER PARTY MAY HAVE TO A TRIAL BY JURY OF ANY CIVIL LITIGATION RELATED TO THIS AGREEMENT. Nothing in this Agreement is intended to serve as a waiver of sovereign immunity, or of any other immunity, defense, or privilege enjoyed by the County pursuant to Section 768.28, Florida Statutes.

Article 14. CIVIL RIGHTS.

The Contractor agrees to comply with pertinent statutes, Executive Orders and such rules as are promulgated to ensure that no person shall, on the grounds of race, creed, color, national origin, sex, age, or disability be excluded from participating in any activity conducted with or benefiting from Federal assistance. This provision binds the Contractor and subcontractors from the bid solicitation period through the completion of the contract. This provision is in addition to that required by Title VI of the Civil Rights Act of 1964.

ARTICLE 15. COMPLIANCE WITH NONDISCRIMINATION REQUIREMENTS.

During the performance of this Agreement, the Contractor, for itself, its assignees, and successors in interest, agrees as follows:

- a. Compliance with Regulations: The Contractor will comply with the Title VI List of Pertinent Nondiscrimination Acts and Authorities, as they may be amended from time to time, which are herein incorporated and attached hereto as Attachment "C".
- b. Nondiscrimination: The Contractor, with regard to the work performed by it during the Agreement, will not discriminate on the grounds of race, color, or national origin in the selection and retention of subcontractors, including procurements of materials and leases of equipment. The Contractor will not participate directly or indirectly in the discrimination prohibited by the Nondiscrimination Acts and Authorities, including employment practices when the contract covers any activity, project, or program set forth in Appendix B of 49 CFR part 21.
- c. Solicitations for Subcontracts, including Procurements of Materials and Equipment: In all solicitations, either by competitive bidding or negotiation made by the Contractor for work to be performed under a subcontract, including procurements of materials, or leases of equipment, each potential subcontractor or supplier will be notified by the Contractor of the contractor's obligations under this contract and the Nondiscrimination Acts and Authorities on the grounds of race, color, or national origin.
- d. Information and Reports: The Contractor will provide all information and reports required by the Acts, the Regulations, and directives issued pursuant thereto and will permit access to its books, records, accounts, other sources of information, and its facilities as may be determined by the County or other governmental entity to be pertinent to ascertain compliance with such Nondiscrimination Acts and Authorities and instructions. Where any information required of a contractor is in the exclusive possession of another who fails or refuses to furnish the information, the Contractor will so certify to the County or the other governmental entity, as appropriate, and will set forth what efforts it has made to obtain the information.
- e. Sanctions for Noncompliance: In the event of a Contractor's noncompliance with the non-discrimination provisions of this contract, the County will impose such contract sanctions as it or another applicable state or federal governmental entity may determine to be appropriate, including, but not limited to:
 - a. Withholding payments to the Contractor under the Agreement until the Contractor complies; and/or
 - b. Cancelling, terminating, or suspending the Agreement, in whole or in part.
- f. Incorporation of Provisions: The Contractor will include the provisions of paragraphs one through six in every subcontract, including procurements of materials and leases of equipment, unless exempt by the Acts, the Regulations, and directives issued pursuant thereto. The Contractor will take action with respect to any subcontract or procurement as the County may direct as a means of enforcing such provisions including sanctions for noncompliance. Provided, that if the Contractor becomes involved in, or is threatened with litigation by a subcontractor, or supplier because of such direction, the Contractor may request the County to enter into any litigation to protect the interests of the County. In addition, the Contractor may request the United States to enter into the litigation to protect the interests of the United States.

ARTICLE 16. COMPLIANCE WITH LAWS.

Contractor shall secure any and all permits, licenses and approvals that may be required in order to perform the Services, shall exercise full and complete authority over Contractor's personnel, shall comply with all workers' compensation, employer's liability and all other federal, state, county, and municipal laws, ordinances, rules and regulations required of an employer performing services such as the Services, and shall make all reports and remit all withholdings or other deductions from the compensation paid to Contractor's personnel as may be required by any federal, state, county, or municipal law, ordinance, rule, or regulation.

ARTICLE 17. CONFLICT OF INTEREST.

The Contractor covenants that it presently has no interest and shall not acquire any interest, directly or indirectly which could conflict in any manner or degree with the performance of the Services. The Contractor further covenants that in the performance of this Agreement, no person having any such interest shall knowingly be employed by the Contractor. The Contractor guarantees that he/she has not offered or given to any member of, delegate to the Congress of the United States, any or part of this contract or to any benefit arising therefrom.

ARTICLE 18. INDEPENDENT CONTRACTOR.

Contractor enters into this Agreement as, and shall continue to be, an independent contractor. All services shall be performed only by Contractor and Contractor's employees/subcontractors. Under no circumstances shall Contractor or any of Contractor's employees/subcontractors look to the County as his/her employer, or as partner, agent or principal. Neither Contractor, nor any of Contractor's employees/subcontractors, shall be entitled to any benefits accorded to the County's employees, including without limitation worker's compensation, disability insurance, vacation or sick pay. Contractor shall be responsible for providing, at Contractor's expense, and in Contractor's name, unemployment, disability, worker's compensation and other insurance as well as licenses and permits usual and necessary for conducting the services to be provided under this Agreement

ARTICLE 19. THIRD PARTY BENEFICIARIES.

It is specifically agreed between the parties executing this Agreement that it is not intended by any of the provisions of any part of the Agreement to create in the public or any member thereof, a third party beneficiary under this Agreement, or to authorize anyone not a party to this Agreement to maintain a suit for personal injuries or property damage pursuant to the terms or provisions of this Agreement.

ARTICLE 20. INDEMNIFICATION AND WAIVER OF LIABILITY.

The Contractor agrees, to the fullest extent permitted by law, to defend, indemnify and hold harmless the County, its agents, representatives, officers, directors, officials and employees from and against claims, damages, losses and expenses (including but not limited to attorney's fees, court costs and costs of appellate proceedings) relating to, arising out of or resulting from the Contractor's negligent acts, errors, mistakes or omissions relating to professional Services performed under this Agreement. The Contractor's duty to defend, hold harmless and indemnify the County its agents, representatives, officers, directors, officials and employees shall arise in connection with any claim, damage, loss or expense that is attributable to bodily injury; sickness; disease; death; or injury to impairment, or destruction of tangible property including loss of use resulting therefrom, caused by any negligent acts, errors, mistakes or omissions related to Services in the performance of this Agreement including any person for whose acts, errors, mistakes or omissions

the Contractor may be legally liable. The parties agree that TEN DOLLARS (\$10.00) represents specific consideration to the Contractor for the indemnification set forth herein.

The waiver by a party of any breach or default in performance shall not be deemed to constitute a waiver of any other or succeeding breach or default. The failure of the County to enforce any of the provisions hereof shall not be construed to be a waiver of the right of the County thereafter to enforce such provisions.

ARTICLE 21. TAXES AND ASSESSMENTS.

Contractor agrees to pay all sales, use, or other taxes, assessments and other similar charges when due now or in the future, required by any local, state or federal law, including but not limited to such taxes and assessments as may from time to time be imposed by the County in accordance with this Agreement. Contractor further agrees that it shall protect, reimburse and indemnify County from and assume all liability for its tax and assessment obligations under the terms of the Agreement.

The County is exempt from payment of Florida state sales and use taxes. The Contractor shall not be exempted from paying sales tax to its suppliers for materials used to fulfill contractual obligations with the County, nor is the Contractor authorized to use the County's tax exemption number in securing such materials.

The Contractor shall be responsible for payment of its own and its share of its employees' payroll, payroll taxes, and benefits with respect to this Agreement.

ARTICLE 22. PROHIBITION AGAINST CONTRACTING WITH SCRUTINIZED COMPANIES.

Pursuant to Florida Statutes Section 215.4725, contracting with any entity that is listed on the Scrutinized Companies that Boycott Israel List or that is engaged in the boycott of Israel is prohibited. Contractors must certify that the company is not participating in a boycott of Israel. Any contract for goods or services of One Million Dollars (\$1,000,000) or more shall be terminated at the County's option if it is discovered that the entity submitted false documents of certification, is listed on the Scrutinized Companies with Activities in Sudan List, the Scrutinized Companies with Activities in the Iran Petroleum Energy Sector List, or has been engaged in business operations in Cuba or Syria after July 1, 2018.

Any contract entered into or renewed after July 1, 2018 shall be terminated at the County's option if the company is listed on the Scrutinized Companies that Boycott Israel List or engaged in the boycott of Israel. Contractors must submit the certification that is attached to this agreement as Attachment "D". Submitting a false certification shall be deemed a material breach of contract. The County shall provide notice, in writing, to the Contractor of the County's determination concerning the false certification. The Contractor shall have ninety (90) days following receipt of the notice to respond in writing and demonstrate that the determination was in error. If the Contractor does not demonstrate that the County's determination of false certification was made in error, then the County shall have the right to terminate the contract and seek civil remedies pursuant to Florida Statute Section 215.4725.

ARTICLE 23. INCONSISTENCIES AND ENTIRE AGREEMENT.

If there is a conflict or inconsistency between any term, statement, requirement, or provision of any attachment attached hereto, any document or events referred to herein, or any document incorporated into this Agreement, the term, statement, requirement, or provision contained in this Agreement shall prevail and be given superior effect and priority over any conflicting or inconsistent term, statement, requirement

or provision contained in any other document or attachment, including but not limited to Attachments listed in Section 1.

ARTICLE 24. SEVERABILITY.

If any term or condition of this Contract shall be deemed, by a court having appropriate jurisdiction, invalid or unenforceable, the remainder of the terms and conditions of this Contract shall remain in full force and effect. This Contract shall not be more strictly construed against either party hereto by reason of the fact that one party may have drafted or prepared any or all the terms and provisions hereof.

ARTICLE 25. ENTIRE AGREEMENT.

This Agreement and Exhibits A-D contains the entire agreement of the parties, and may be amended, waived, changed, modified, extended or rescinded only by in writing signed by the party against whom any such amendment, waiver, change, modification, extension and/or rescission is sought.

ARTICLE 26. REPRESENTATION OF AUTHORITY TO CONTRACTOR/SIGNATORY.

The individual signing this Agreement on behalf of Contractor represents and warrants that he or she is duly authorized and has legal capacity to execute and deliver this Agreement. The signatory represents and warrants to the County that the execution and delivery of this Agreement and the performance of the Services and obligations hereunder have been duly authorized and that the Agreement is a valid and legal agreement binding on the Contractor and enforceable in accordance with its terms.

(Remainder of this Page Intentionally Left Blank)

IN WITNESS WHEREOF, County, and Contractor have signed this Agreement. All portions of the Contract Documents have been signed, initialed or identified by County, and Contractor, or identified by Engineer on their behalf.

This Agreement will be effective on March 16, 2022 (which is the Effective Date of the Agreement).

WITNESS:

Signature

Priscilla Robbins
Print Name

BY: 
Josh Livingston, General Contractor

ATTEST:

Donald C. Spencer, Clerk of Court



SANTA ROSA COUNTY, FLORIDA

BY: 
Robert A. "Bob" Colc, Chairman

Exhibit A

SANTA ROSA COUNTY, FLORIDA



ITB # 22-017 Navarre Beach Boat Ramp Private Aids to Navigation

February 2022

**OWNER: BOARD OF COUNTY COMMISSIONERS
SANTA ROSA COUNTY, FLORIDA**

**SAM PARKER
ROBERT A. "BOB" COLE
JAMES CALKINS
DAVE PIECH
COLTEN WRIGHT**

**-DISTRICT I
-DISTRICT II
-DISTRICT III
-DISTRICT IV
-DISTRICT V**

SECTION I.
INVITATION TO BID

This Page Intentionally Left Blank

SECTION II.
STD ITB – BID INSTRUCTIONS, SUBMITTAL
REQUIREMENTS AND GENERAL BID
REQUIREMENTS

This Page Intentionally Left Blank

PRE-BID ACTIVITY

Except as provided in this section, respondents are prohibited from contacting or lobbying the County, County Administrator, Commissioners, County staff, and Review Committee members, or any other person authorized on behalf of the County related or involved with the solicitation. All inquiries on the scope of work, specifications, additional requirements, attachments, terms and general conditions or instructions, or any issue must be directed in writing, by US mail or email to: Santa Rosa County Procurement Office, 6495 Caroline Street, Suite L Milton Fl. 32570. Email; Bidinfo@santarosa.fl.gov.

All questions or inquiries must be received no later than the last day for questions stated in the ITB & Legal Notice. Any addenda or other modification to the bid documents will be issued by the County five (5) days prior to the date and time of bid closing, as written addenda, and will be posted to the Santa Rosa County website at <https://www.santarosa.fl.gov> keyword; Bids.

Such written addenda or modification shall be part of the bid documents and shall be binding upon each respondent. Each respondent is required to acknowledge receipt of any and all addenda in writing and submit with their bid. No respondent may rely upon any verbal modification or interpretation.

PROPOSED SCHEDULE

Invitation to Bid Published	February 17, 2022
Deadline for Questions	February 24, 2022 – 12:00 P.M.
Bids Due	March 3, 2022, 10:15 A.M.

PREPARATION OF BID

A Bid form is included in these specifications. The Owner may consider as informal any bid on which there is an alteration of or departure from the Bid Form hereto attached. The respondent shall submit bids in accordance with the public notice.

All blanks in the bid documents shall be completed by printing in ink or by typewriter in both words and numbers with the amounts extended, totaled and the bid signed. A bid price shall be indicated for each section, bid item, alternative, adjustment unit price item, and unit price item listed therein, or the words “No Bid”, “No Change”, or “Not Applicable” entered. No changes shall be made to the phraseology of the form or in the items mentioned therein. In case of any discrepancy between the written amount and the numerical figures, the written amount shall govern. Any bid which contains any omissions, erasures, alterations, additions, irregularities of any kind, or items not called for which shall in any manner fail to conform to the conditions of public notice inviting bids may be rejected.

A bid submitted by a partnership shall be executed in the partnership name and signed by a partner (whose title must appear under the signature). The official address of the partnership shall be shown below the signature.

BID INSTRUCTIONS, SUBMITTAL REQUIREMENTS AND GENERAL BID CONDITIONS

A bid submitted by a limited liability company shall be executed in the name of the firm by a member and accompanied by evidence of authority to sign. The state of formation of the firm and the official address of the firm must be shown below the signature.

A bid submitted by an individual shall show the respondent's name and official address.

A bid submitted by a joint venture shall be executed by each joint venture in the manner indicated on the bid form. The official address of the joint venture must be shown below the signature.

It is preferred that all signatures be in blue ink with the names type or printed below the signature. Santa Rosa County does not accept electronic signatures in bid submissions.

The bid shall contain an acknowledgement of receipt of all Addenda, the numbers of which shall be filled in on the form. The address and telephone # for communications regarding the bid shall be shown.

If the respondent is an out-of-state corporation, the bid shall contain evidence of respondent's authority and qualification to do business as an out-of-state corporation in the State of Florida. A state contractor license # for the State of Florida shall also be included on the bid form. Respondent shall be licensed in accordance with the requirements of Chapter 489, Florida Statutes.

The Bid shall be based upon the completion of the Work according to the drawings and specifications, together with all addenda thereto.

Bids must include lump sum pricing. Use Bid Form provided in this document. All proposed fees and costs must be broken down and disclosed in the bid.

SUBMITTAL OF BID

A bid shall be submitted no later than the date and time prescribed and at the place indicated in the advertisement or invitation to bid and shall be sealed and clearly labeled with the words "22-017 Navarre Beach Boat Ramp Private Aids To Navigation", name of bidder and date and time of opening so as to guard against premature opening of any bid and shall be accompanied by the bid security and other required documents. It is the respondent's responsibility to assure that its bid is delivered at the proper time and place. Offers by email, facsimile, or telephone will NOT be accepted.

Each contractor's submittal shall include all the items listed on the Bidders Submission Checklist, in order, with the Checklist on the top of the submission.

INTEGRITY OF BID DOCUMENTS

Respondents shall use the original Bid documents provided by the Santa Rosa County Procurement Office and enter information only in the spaces where a response is requested. Respondents may use an attachment to the Bid documents if sufficient space is not available. Any modifications or alterations to the original bid documents by the respondent, whether intentional or otherwise, will constitute grounds for rejection of a bid. Any such modification or alteration that a respondent wishes to propose must be clearly stated in the respondent's

response in the form of an addendum to the original bid documents.

WITHDRAWAL OF SUBMITTALS

Any Respondent may withdraw its Submittal, either personally or by written request, at any time prior to the scheduled time for opening Submittals.

INTERPRETATION

No oral interpretation will be made to any Bidder as to the meaning of the drawings or specifications. Every interpretation made to a Bidder will be in the form of an Addendum to the specifications. Addenda will be furnished to each Bidder, but it shall be the Bidder's responsibility to make inquiry as to Addenda issued. All such addenda shall become part of the contract and all Bidders shall be bound by such Addenda whether or not received by the Bidders.

BIDS TO REMAIN SUBJECT TO ACCEPTANCE

All bids will remain subject to acceptance or rejection by Santa Rosa County for sixty (60) calendar days after the day of the bid opening. The County may, in its sole discretion, release any bid and return the bid security prior to the end of this period.

CONDITIONAL & INCOMPLETE BIDS

Santa Rosa County specifically reserves the right to reject any conditional bid.

ADDITION/DELETION OF ITEM

The County reserves the right to add or delete any item from this bid or resulting contract when deemed to be in the County's best interest.

SPECIFICATION EXCEPTIONS

Specifications are based on the most current literature available. Respondent shall clearly list any change in the manufacturer's specifications which conflict with the bid specifications. Respondent must also explain any deviation from the bid specification in writing, as a foot note on the applicable bid page and enclose a copy of the manufacturer's specifications data detailing the changed item(s) with their bid. Failure of the respondent to comply with these provisions will result in respondents being held responsible for all costs required to bring the equipment in compliance with bid specifications.

FAMILIARITY WITH LAWS

All applicable Federal and State laws, County and municipal ordinances, orders, rules and regulations of all authorities having jurisdiction over the project shall apply to the bid throughout, and they will be deemed to be included in the contract the same as though they were written in full therein.

EXAMINATION OF DOCUMENTS AND SITE

Before submitting their proposal, the Bidder shall familiarize themselves with the nature and extent of the work and any local conditions that may in any manner affect the work to be done and the equipment, materials, and labor required. Bidder shall also examine all drawings, specifications, addenda and other Contract Documents to be thoroughly informed regarding any and all conditions and requirements that may in any manner affect the work to be performed under the contract.

RIGHT TO REJECT PROPOSAL

The Owner reserves the right to waive informalities in bids to reject any or all bids with or without cause and accept the bid that in its judgment is in the best interest of the County.

DISQUALIFICATION OF RESPONDENTS

Any of the following reasons may be considered as sufficient for the disqualification of a respondent and the rejection of its bid:

Submission of more than one proposal for the same work from an individual, firm or corporation under the same or different name. Evidence that the respondent has a financial interest in the firm of another respondent for the same work.

Evidence of collusion among respondents. Participants in such collusion will receive no recognition as respondents for any future work of the County until such participant has been reinstated as a qualified respondent.

Uncompleted work which in the judgment of the County might hinder or prevent the prompt completion of additional work if awarded.

Failure to pay or satisfactorily settle all bills due for labor and material on former contracts in force at the time of advertisement of proposals. Default under previous contract.

Listing of the respondent by any Local, State or Federal Government on its barred/suspended vendor list.

DISCRIMINATION

An entity or affiliate who has been placed on the discriminatory vendor list may not submit a bid on a contract to provide goods or services to a public entity, may not submit a bid on a contract with a public entity for the construction or repair of a public building or public work, may not submit bids on leases of real property to a public entity, may not award or perform work as a contractor, supplier, subcontractor, or consultant under contract with any public entity, and may not transact business with any public entity.

REVIEW OF PROCUREMENT DOCUMENTS

Per Florida Statute 119.071 (1) 2, sealed bids, proposals, or replies received by the County pursuant to a competitive solicitation are exempt from public disclosure until such time as the County provides notice of an intended decision or until 30 days after opening the bids, proposals, or final replies, whichever is earlier.

COMPLIANCE WITH FLORIDA STATUTE 119.0701

The Respondent shall comply with all the provisions of section 119.0701, Florida Statutes

relating to the public records which requires, among other things, that the Respondent: (a) Keep and maintain public records; (b) Provide the public with access to public records on the same terms and conditions that the public agency would provide the records; (c) ensure that public records that are exempt or confidential and exempt from public records disclosure requirements are not disclosed except as authorized by law; and (d) Meet all requirements for retaining public records and transfer, at no cost, to the public agency all public records in possession of the respondent upon termination of the contract.

IF THE CONTRACTOR HAS QUESTIONS REGARDING THE APPLICATION OF CHAPTER 119, FLORIDA STATUTES, TO THE CONTRACTOR'S DUTY TO PROVIDE PUBLIC RECORDS RELATING TO THIS CONTRACT, CONTACT THE CUSTODIAN OF PUBLIC RECORDS AT (850) 983-1925, wandap@santarosa.fl.gov; 6495 CAROLINE STREET, SUITE C, MILTON, FLORIDA 32570.

SUSPENSION OR TERMINATION FOR CONVENIENCE

The County may, at any time, without cause, order Respondent in writing to suspend, delay or interrupt the work in whole or in part for such period of time as the County may determine, or to terminate all or a portion of the Contract for the County's convenience. Upon such termination, the Contract Price earned to the date of termination shall be paid to Respondent, but Respondent waives any claim for damages, including loss of profits arising out of or related to the early termination. Those Contract provisions which by their nature survive final acceptance shall remain in full force and effect. If the County orders a suspension, the Contract price and Contract time may be adjusted for increases in the cost and time caused by suspension, delay or interruption. No adjustment shall be made to the extent that performance is, was or would have been so suspended, delayed or interrupted by reason for which Respondent is responsible; or that an equitable adjustment is made or denied under another provision of this Contract.

FAILURE OF PERFORMANCE/DELIVERY

In case of default by the respondent, the County after due notice (oral or written) may procure the necessary supplies or services from other sources and hold the respondent responsible for difference in cost incurred. Continuous instances of default shall result in cancellation of the award and removal of the respondent from the bid list for duration of one (1) year, at the option of the County.

AUDIT

If requested, respondent shall permit the County or an authorized, independent audit agency to inspect all data and records of respondent relating to its performance and its subcontracts under this bid from the date of the award through three (3) years after the expiration of contract.

NON-COLLUSION

Respondent certifies that it has entered into no agreement to commit a fraudulent, deceitful, unlawful or wrongful act, or any act which may result in an unfair advantage over other

respondents. See Florida Statute 838.22.

PUBLIC ENTITY CRIME INFORMATION

Pursuant to Florida Statute 287.133, a respondent may not be awarded or perform work as a contractor, supplier, subcontractor, or consultant under a contract with any public entity; and may not transact business with any public entity in excess of the threshold amount provided in s. 287.017 for CATEGORY TWO for a period of 36 months following the date of being placed on the convicted vendor list.

Note: For respondent's convenience, this certification form is enclosed and is made a part of the bid package.

INVESTIGATION OF RESPONDENT

The County may make such investigations, as it deems necessary to determine the stability of the respondent to perform the work and that there is no conflict of interest as it relates to the project. The respondent shall furnish to the Owner any additional information and financial data for this purpose as the County may request.

CONE OF SILENCE CLAUSE

The Santa Rosa County Board of County Commissioners has established a solicitation silence policy (Cone of Silence Clause) that prohibits oral and written communication regarding all formal solicitations for goods and services (formal bids, Request for Proposals, Requests for Qualifications) issued by the Board through the Procurement Office. The period commences from the date of advertisement until award of contract. All communications shall be directed to the Procurement Office.

Note: For respondent's convenience, this certification form is enclosed and is made a part of the bid package.

TIME OF COMPLETION

The entire project shall be completed within 90 calendar days after the Notice to Proceed date. The date of substantial completion of the work or designated portion thereof is the date certified by the Engineer when construction is sufficiently complete and approved in accordance with the Contract Documents so the Owner can occupy or utilize the work for the use which it was intended.

The date of substantial completion of the work or designated portion thereof is the date certified by the Engineer when construction is sufficiently complete and approved in accordance with the Contract Documents so the Owner can occupy or utilize the work for the use which it was intended.

Liquidated damages will be established in the amount of \$882.00 per calendar day for each calendar day after completion date if the work is not substantially complete as certified by the Engineer.

Payment requests approved by the Engineer for work completed satisfactorily in accordance with the Contract Documents shall be reduced by a five percent (5%) retainer. The five percent (5%) retainer shall be retained by the Owner until final completion and acceptance of the work by the Engineer and Santa Rosa County, Florida.

EVALUATION OF BIDS AND AWARD OF CONTRACT

Santa Rosa County Staff will review all bids and will provide the recommendation to award to the Procurement Office, the County Administrator and the Board of County Commissioners. The County will award the bid to the responsive and responsible vendor(s) with the lowest responsive bid(s). The County reserves the right to award the bid to the respondent submitting a responsive bid with a resulting negotiated agreement which is most advantageous and in the best interest of the County, and to reject any and all bids or to waive any irregularity or technicality in bids received. Santa Rosa County shall be the sole judge of the bid and the resulting negotiated agreement that is in its best interest and its decision shall be final.

Santa Rosa County reserves its right to reject any or all Bids, including without limitation nonconforming, nonresponsive, unbalanced or conditional Bids. The County further reserves the right to reject the Bid of any Bidder whom it finds after reasonable inquiry and evaluation to not be responsible. In evaluating Bidders, the County may consider the qualifications of Bidders and may consider the qualifications and experience of Subcontractors, Suppliers, and other individuals or entities proposed for those portions of the Work for which the identity of Subcontractors, Suppliers, and other individuals or entities must be submitted with the Bid Form.

Santa Rosa County reserves the right to waive any informalities or reject any and all bids, in whole or part, to utilize any applicable state contracts in lieu of or in addition to this bid and to accept the bid that in its judgment will best serve the interest of the County.

Santa Rosa County reserves the right to reject any conditional bids and will normally reject those which made it impossible to determine the true amount of the bid. Each item must be bid separately, and no attempt is to be made to tie any item or items to any other item or items.

FORM OF AGREEMENT:

The Contract form shall be provided by the Procurement Office. The successful contractor shall, within 10 days after receipt of the Notice of Award and the contract forms or documents, sign and deliver to the Procurement Office all required contract documents. The awarded contractor shall also deliver the policies of insurance or insurance certificate as required. All insurance documents shall be approved by Santa Rosa County Procurement Office before the successful contractor may proceed with the work.

Contractor is responsible for submitted along with their response any exceptions it has to the standard terms of contract, within the attached sample contract. Failure to submit exceptions at time of submittal of the response will be considered a waiver by bidder to contest or request

exception to the contract provisions. Any exceptions to the standard terms of contract will be taken into consideration as part of the County's review of the response. The County reserves the right to reject bids depending on the substance of the exceptions.

BID GUARANTEE:

Each bid shall be submitted on the bid form provided and must be accompanied by a Certified Check or Bid Bond in the amount of five percent (5%) of the Base Bid, and copies of all required licenses. Such Bid Bond or Check is given with the understanding and agreement that it guarantees:

(1) that the bidder will not withdraw his bid for a period of 60 days after the bids have been opened; and, (2) that if his bid is accepted, the Bidder will enter into the written Contract with Santa Rosa County and furnish the required Performance Bond Payment Bond Insurance Certificates, within 10 days after receipt of Notice of Award of his bid. Pursuant to Florida Statutes, Section 255.05, should the contract exceed \$100,000, the Contractor shall be required to execute and record performance and payment bonds. These bonds must state the name and principal business address of both the principal and the surety and a description of the project sufficient to identify it. In the event the bidder fails to comply with any of these conditions and requirements in whole or in part, the full amount of the bond or check shall be automatically forfeited to Santa Rosa County as damages on account of the default of the bidder.

SECTION III.
SANTA ROSA COUNTY DOCUMENTS AND FORMS

This Page Intentionally Left Blank

BID FORM

(May be copied by the Bidder on his own letterhead)

TO: Santa Rosa County Procurement Department
Attention Procurement Officer
6495 Caroline Street, Suite L
Milton, Florida 32570

REFERENCE: **ITB 22-017 Navarre Beach Boat Ramp Private Aids To Navigation**

BASE BID PRICE: \$ _____

To whom it may concern,

I, _____ have received and reviewed the Bidding Documents consisting of Drawings and Specifications (Project Manual) entitled ITB 22-017 NAVARRE BEACH BOAT RAMP PRIVATE AIDS TO NAVIGATION, prepared by Santa Rosa County Engineering, 6051 Old Bagdad Highway, Suite 300, Milton, Florida 32570, and Baskerville-Donovan, Inc., 449 W. Main Street, Pensacola, FL 32502

I have also received Addenda Numbers _____ and have included their provisions in my Bid.

In submitting the Bid, I agree:

1. To hold my bid in full force and effect for a period of sixty (60) calendar days after the time of the opening of this Bid.
2. To accept the provisions of the Instructions to Bidders regarding disposition of Bid Guarantee.
3. To enter into and execute a Contract within 10 (ten) calendar days after said Contract is delivered to me, if awarded on the basis of this Bid.
4. To accomplish the work in accordance with the Contract Documents.
5. To commence work under this Contract on or before a date to be specified in written "Notice of Proceed" by the Procurement Department and to complete project within Ninety (90) calendar days thereafter.
6. To pay as liquidated damages, the sum of \$882.00 for each consecutive calendar day after completion date, as called for in the Contract Agreement as modified.
7. Provide Santa Rosa County with performance Bonds and adhere to Supplementary Conditions.

I will construct this project for the lump sum price of:

Navarre Beach Boat Ramp Private Aids to Navigation					
Bid Form					
Item No.	Item Description	Item Qty.	Qty. Unit	Unit Price	Extended Amount
GENERAL					
G-1	Mobilization	1	LS		
G-2	Turbidity Curtains Per Permit Req. (Includes Testing & Monitoring)	1	LS		
G-3	Provide As-Built Drawings (Includes Lat./Long.)	1	LS		
PAToN INSTALLATION					
1-1	Port-Side Channel Markers w/ Lantern	5	EA		
1-2	Port-Side Channel Markers w/o Lantern	2	EA		
1-3	Starboard-Side Channel Markers w/ Lantern	4	EA		
1-4	Starboard Channel Markers w/o Lantern	2	EA		
Total Bid					

This is a lump sum project. The purpose for providing a bid tabulation (if this is included in the bid package by engineer) format is to provide unit prices in case of change order. There is no implied statement by the engineer or Santa Rosa County as to the accuracy of the stated quantities within the bid tab or that the bid tab is all inclusive of the work items within the plans. It is the contractor's responsibility to carefully review the plans, specifications, and project to determine what is needed to do the whole job, and to reflect this in his LUMP SUM BID. This basis of award will be the total base bid for the project.

This project requires a permit which must be acquired by the contractor. Associated fees, for a final fixed price shall be disclosed in your respective scope of work including fee amounts, the issuing entity and if fees shall be paid prior to commencement of work.

FIRM: _____

BY (print): _____

SIGNATURE: _____

TITLE: _____

DATE: _____

MAILING ADDRESS _____

PHONE (____) _____ FAX (____) _____

EMAIL _____

Santa Rosa County
Standard Insurance Requirements
March 2021

Workers' Compensation – meet statutory limits in compliance with the Workers Compensation Laws of Florida. This policy must include Employer Liability with a limit of \$100,000 for each accident, \$500,000 disease policy limit and \$100,000 disease each employee limit.

Commercial General Liability – coverage shall provide minimum limits of liability of \$1,000,000 per occurrence, \$2,000,000 Aggregate, for bodily injury and property damage. This shall include coverage for:

- a. Premises/operations
- b. Products/complete operations
- c. Contractual liability
- d. Independent contractors

Business Auto Liability – coverage shall provide minimum limits \$500,000. Combined Single Limit for bodily injury and property damage. If Split limit coverage is provided Limits of 500,000 per person/500,000 per accident and 500,000 for property damage are required.

This shall include coverage for:

- a. Owned autos
- b. Hired autos
- c. Non-owned autos

Special Requirements:

1) Prior to execution of a contract or agreement, certificates of insurance will be produced that shall provide for the following:

- a. Santa Rosa County shall be named as an additional insured on all coverages except workers' compensation.

- b. Santa Rosa County will be given thirty (30) days' notice prior to cancellation or modification of any stipulated insurance.

2) It is the responsibility of the contractor to ensure that all subcontractors comply with all insurance requirements.

3) *It should be noted that these are minimum requirements which are subject to modification in response to specialized or high hazard operations.*

In the event of unusual circumstances, the County Administrator, or his designee, may adjust these insurance requirements

Additional Insurance Checklist

“If coverage requirements on this checklist are checked and if those limits of the specific coverage are higher, then those limits must be purchased and proof of coverage on COI provided”. Coverages on this checklist are in addition to the standard required county coverages.

Proposal/Project Reference: ITB 22-017 Navarre Beach Boat Ramp Private Aids to Navigation

Required Coverage (Marked by “X”)	Minimum Limits
1. <input type="checkbox"/> Workers Compensation Proprietor/Executive Officers Exclusion not allowed	\$100,000. Employers Liab. \$100,000. Accident –Disease \$500,000. Disease policy Limit
2. <input type="checkbox"/> Commercial General Liability Including Premises operations-Products completed ops Contractual Liability and Personal and advertising Liability	\$1,000,000. CSL \$2,000,000. Annual Aggregate
3. <input checked="" type="checkbox"/> Marine Liability Insurance	\$1,000,000. Per Occurrence
4. <input checked="" type="checkbox"/> Jones Act Coverage	\$1,000,000. Per Occurrence
5. <input type="checkbox"/> Asbestos Removal Liability	\$2,000,000. Per Occurrence
6. <input type="checkbox"/> Medical Malpractice	\$1,000,000 Per Occurrence
7. <input type="checkbox"/> Garage Liability	\$1,000,000. BI/PD- Occurrence
8. <input type="checkbox"/> Garage Keepers Liability	\$500,000. Comprehensive \$500,000. Collision
9. <input type="checkbox"/> Inland Marine- Bailee’s Insurance	\$_____
10. <input type="checkbox"/> Moving and Rigging Floater	Endorsement to CGL
11. <input type="checkbox"/> Crime/Dishonesty Bond	\$_____
12. <input type="checkbox"/> Builders Risk/Installation Floater – Provide coverage in Full amount of Contract.	
13. <input type="checkbox"/> Owner’s Protective Liability	\$_____
14. <input type="checkbox"/> Excess/Umbrella Liability	\$_____

General Requirements

- A. Carrier rating shall be A.M. Best rating of B++V or Better.
- B. Notice of Cancellation or Non-renewal or material change in coverage shall be provided to Santa Rosa County at least 30 days prior to action.
- C. Santa Rosa County shall be named as Additional Insured on all policies except Workers' Compensation.

Approved by the BOCC March 23, 2021

SANTA ROSA COUNTY
BOARD OF COUNTY COMMISSIONERS
GENERAL PROVISIONS

ARTICLE 1: GENERAL PROVISIONS

1.1 BASIC DEFINITIONS

1.1.1 THE CONTRACT DOCUMENTS

The Contract Documents consist of the Agreement between Owner and Contractor (hereinafter the Agreement), Conditions of the Contract (General, Supplementary and other Conditions), Drawings/maps/sketches, Specifications, Addenda issued prior to execution of the Contract, other documents listed in the Agreement and Modifications issued after execution of the Contract. A Modification is (1) a written amendment to the Contract signed by both parties, (2) a Change Order, (3) a Construction Change Directive or (4) a written order for a minor change in the Work issued by the Engineer. Unless specifically enumerated in the Agreement, the Contract Documents do not include other documents such as bidding requirements (advertisement or invitation to bid, Instructions to Bidders, sample forms, the Contractor's bid or portions of Addenda relating to bidding requirements).

1.1.2 THE CONTRACT

The Contract Documents form the Contract for Construction. The Contract represents the entire and integrated agreement between the parties hereto and supersedes prior negotiations, representations or agreements, either written or oral. The Contract may be amended or modified only by a Modification. The Contract Documents shall not be construed to create a contractual relationship of any kind (1) between the Engineer and Contractor, (2) between the Owner and a Subcontractor or Sub-Subcontractor, (3) between the Owner and Engineer or (4) between any persons or entities other than the Owner and Contractor. The Engineer shall, however, be entitled to performance and enforcement of obligations under the Contract intended to facilitate performance of the Engineer's duties.

1.1.3 THE WORK

The term "Work" means the construction and services required by the Contract Documents, whether completed or partially completed, and includes all other labor, materials, equipment and services provided or to be provided by the Contractor to fulfill the Contractor's obligations. The Work may constitute the whole or a part of the Project.

1.1.4 THE PROJECT

The Project is the total construction of which the Work performed under the Contract Documents may be the whole or a part and which may include construction by the Owner or by separate Contractors.

1.1.5 THE DRAWINGS

The Drawings are the graphic and pictorial portions of the Contract Documents showing the design, location and dimensions of the Work, generally including plans, elevations, sections, details, schedules and diagrams.

1.1.6 THE SPECIFICATIONS

The Specifications are that portion of the Contract Documents consisting of the written requirements for materials, equipment, systems, standards and workmanship for the Work, and performance of related services.

1.1.7 THE PROJECT MANUAL

The Project Manual is a volume assembled for the Work which may include the bidding requirements, sample forms, Conditions of the Contract and Specifications.

1.2 CORRELATION AND INTENT OF THE CONTRACT DOCUMENTS

1.2.1 The intent of the Contract Documents is to include all items necessary for the proper execution and completion of the Work by the Contractor. The Contract Documents are complementary, and what is required by one shall be as binding as if required by all; performance by the Contractor shall be required only to the extent consistent with the Contract Documents and reasonably inferable from them as being necessary to produce the indicated results.

1.2.2 Organization of the Specifications into divisions, sections and articles, and arrangement of Drawings shall not control the Contractor in dividing the Work among Subcontractors or in establishing the extent of Work to be performed by any trade.

1.2.3 Unless otherwise stated in the Contract Documents, words which have well-known technical or construction industry meanings are used in the Contract Documents in accordance with such recognized meanings.

1.3 CAPITALIZATION

1.3.1 Terms capitalized in these General Conditions include those which are (1) specifically defined, (2) the titles of numbered articles and identified references to Paragraphs, Subparagraphs and Clauses in the document.

1.4 INTERPRETATION

1.4.1 In the interest of brevity the Contract Documents frequently omit modifying words such as “all” and “any” and articles such as “the” and “an”, but the fact that a modifier or an article is absent from one statement and appears in another is not intended to affect the interpretation of either statement.

1.5 EXECUTION OF CONTRACT DOCUMENTS

1.5.1 The Contract Documents shall be signed by the Owner and Contractor. If either the Owner or Contractor or both do not sign all the Contract Documents, the Engineer shall identify such unsigned Documents upon request.

1.5.2 Execution of the Contract by the Contractor is a representation that the Contractor has visited the site, become generally familiar with local conditions under which the Work is to be performed and correlated personal observations with requirements of the Contract Documents.

1.6 OWNERSHIP AND USE OF DRAWINGS/MAPS/SKETCHES, SPECIFICATIONS AND OTHER INSTRUMENTS OF SERVICE

1.6.1 The Drawings/maps/sketches, Specifications and other documents, including those in electronic form, prepared by the Engineer and the Engineer's consultants are Instruments of Service through which the Work to be executed by the Contractor is described. The Contractor may retain one record set. Neither the Contractor nor any Subcontractor, Sub-Subcontractor or material or equipment supplier shall own or claim a copyright in the Drawings, Specifications and other documents prepared by the Engineer or the Engineer's consultants, and unless otherwise indicated the Engineer and the Engineer's consultants shall be deemed the authors of them and will retain all common law, statutory and other reserved rights, in addition to the copyrights. All copies of Instruments of Service, except the Contractor's record set, shall be returned or suitably accounted for to the Engineer, on request, upon completion of the Work. The Drawings, Specifications and other documents prepared by the Engineer and the Engineer's consultants, and copies thereof furnished to the Contractor, are for use solely with respect to this Project. They are not to be used by the

Contractor or any Subcontractor, Sub- Subcontractor or material or equipment supplier on other projects or for additions to this Project outside the scope of the Work without the specific written consent of the Owner, Engineer and the Engineer's consultants. The Contractor, Subcontractors, Sub-Subcontractors and material or equipment suppliers are authorized to use and reproduce applicable portions of the Drawings, Specifications and other documents prepared by the Engineer and the Engineer's consultants appropriate to and for use in the execution of their Work under the Contract Documents. All copies made under this authorization shall bear the statutory copyright notice, if any, shown on the Drawings, Specifications and other documents prepared by the Engineer and the Engineer's consultants. Submittal or distribution to meet official regulatory requirements or for other purposes in connection with this Project is not to be construed as publication in derogation of the Engineer's or Engineer's consultants' copyrights or other reserved rights.

ARTICLE 2: OWNER

2.1 GENERAL

2.1.1 The Owner is the person or entity identified as such in the Agreement and is referred to throughout the Contract Documents as if singular in number. The Owner shall designate in writing a representative who shall have express authority to bind the Owner with respect to all matters requiring the Owner's approval or authorization. Except as otherwise provided in Subparagraph **4.2.1**, the Engineer does not have such authority. The term "Owner" means the Owner or the Owner's authorized representative.

2.1.2 The Owner shall furnish to the Contractor within fifteen days after receipt of a written request, information necessary and relevant for the Contractor to evaluate, give notice of or enforce mechanic's lien rights. Such information shall include a correct statement of the record legal title to the property on which the Project is located, usually referred to as the site, and the Owner's interest therein.

2.2 INFORMATION AND SERVICES REQUIRED OF THE OWNER

2.2.1 The Owner shall, at the written request of the Contractor, prior to commencement of the Work and thereafter, furnish to the Contractor reasonable evidence that financial arrangements have been made to fulfill the Owner's obligations under the Contract. Furnishing of such evidence shall be a condition precedent to commencement or continuation of the Work. After such evidence has been furnished, the Owner shall not materially vary such financial arrangements without prior notice to the Contractor.

2.2.2 Except for permits and fees, including those required under Subparagraph **3.7.1**, which are the responsibility of the Contractor under the Contract Documents, the Owner shall secure and pay for necessary approvals, easements, assessments and charges required for construction, use or occupancy of permanent structures or for permanent changes in existing facilities.

2.2.3 The Owner shall furnish surveys describing physical characteristics, legal limitations and utility locations for the site of the Project, and a legal description of the site. The Contractor shall be entitled to rely on the accuracy of information furnished by the Owner but shall exercise proper precautions relating to the safe performance of the Work.

2.2.4 Information or services required of the Owner by the Contract Documents shall be furnished by the Owner with reasonable promptness. Any other information or services relevant to the Contractor's performance of the Work under the Owner's control shall be furnished by the Owner after receipt from the Contractor of a written request for such information or services.

2.2.5 Unless otherwise provided in the Contract Documents, the Contractor will be furnished, free of charge, such copies of Drawings and Project Manuals as are reasonably necessary for execution of the Work.

2.3 OWNER'S RIGHT TO STOP THE WORK

2.3.1 If the Contractor fails to correct Work which is not in accordance with the requirements of the Contract Documents as required by Paragraph 12.2 or persistently fails to carry out Work in accordance with the Contract Documents, the Owner may issue a written order to the Contractor to stop the Work, or any portion thereof, until the cause for such order has been eliminated; however, the right of the Owner to stop the Work shall not give rise to a duty on the part of the Owner to exercise this right for the benefit of the Contractor or any other person or entity, except to the extent required by Subparagraph 6.1.3.

2.4 OWNER'S RIGHT TO CARRY OUT THE WORK

2.4.1 If the Contractor defaults or neglects to carry out the Work in accordance with the Contract Documents and fails within a seven-day period after receipt of written notice from the Owner to commence and continue correction of such default or neglect with diligence and promptness, the Owner may after such seven-day period give the Contractor a second written notice to correct such deficiencies within a three-day period. If the Contractor within such three-day period after receipt of such second notice fails to commence and continue to correct any deficiencies, the Owner may, without prejudice to other remedies the Owner may have, correct such deficiencies. In such case an appropriate Change Order shall be issued deducting from payments then or thereafter due the Contractor the reasonable cost of correcting such deficiencies, including Owner's expenses and compensation for the Engineer's additional services made necessary by such default, neglect or failure. Such action by the Owner and amounts charged to the Contractor are both subject to prior approval of the Engineer. If payments then or thereafter due the Contractor are not sufficient to cover such amounts, the Contractor shall pay the difference to the Owner.

ARTICLE 3: CONTRACTOR

3.1 GENERAL

3.1.1 The Contractor is the person or entity identified as such in the Agreement and is referred to throughout the Contract Documents as if singular in number. The term "Contractor" means the Contractor or the Contractor's authorized representative.

3.1.2 The Contractor shall perform the Work in accordance with the Contract Documents.

3.1.3 The Contractor shall not be relieved of obligations to perform the Work in accordance with the Contract Documents either by activities or duties of the Engineer in the Engineer's administration of the Contract, or by tests, inspections or approvals required or performed by persons other than the Contractor.

3.2 REVIEW OF CONTRACT DOCUMENTS AND FIELD CONDITIONS BY CONTRACTOR

3.2.1 Since the Contract Documents are complementary, before starting each portion of the Work, the Contractor shall carefully study and compare the various Drawings and other Contract Documents relative to that portion of the Work, as well as the information furnished by the Owner pursuant to Subparagraph 2.2.3, shall take field measurements of any existing conditions related to that portion of the Work and shall observe any conditions at the site affecting it. These obligations are for the purpose of facilitating construction by the Contractor and are not for the purpose of discovering errors, omissions, or inconsistencies in the Contract Documents; however, any errors, inconsistencies or

omissions discovered by the Contractor shall be reported promptly to the Engineer as a request for information in such form as the Engineer may require.

3.2.2 Any design errors or omissions noted by the Contractor during this review shall be reported promptly to the Engineer, but it is recognized that the Contractor's review is made in the Contractor's capacity as a Contractor and not as a licensed design professional unless otherwise specifically provided in the Contract Documents. The Contractor is not required to ascertain that the Contract Documents are in accordance with applicable laws, statutes, ordinances, building codes, and rules and regulations, but any nonconformity discovered by or made known to the Contractor shall be reported promptly to the Engineer.

3.2.3 If the Contractor believes that additional cost or time is involved because of clarifications or instructions issued by the Engineer in response to the Contractor's notices or requests for information pursuant to Subparagraphs **3.2.1** and **3.2.2**, the Contractor shall make Claims as provided in Subparagraphs **4.3.6** and **4.3.7**. If the Contractor fails to perform the obligations of Subparagraphs **3.2.1** and **3.2.2**, the Contractor shall pay such costs and damages to the Owner as would have been avoided if the Contractor had performed such obligations. The Contractor shall not be liable to the Owner or Engineer for damages resulting from errors, inconsistencies or omissions in the Contract Documents or for differences between field measurements or conditions and the Contract Documents unless the Contractor recognized such error, inconsistency, omission or difference and knowingly failed to report it to the Engineer.

3.3 SUPERVISION AND CONSTRUCTION PROCEDURES

3.3.1 The Contractor shall supervise and direct the Work, using the Contractor's best skill and attention. The Contractor shall be solely responsible for and have control over construction means, methods, techniques, sequences and procedures and for coordinating all portions of the Work under the Contract, unless the Contract Documents give other specific instructions concerning these matters. If the Contract Documents give specific instructions concerning construction means, methods, techniques, sequences or procedures, the Contractor shall evaluate the jobsite safety thereof and, except as stated below, shall be fully and solely responsible for the jobsite safety of such means, methods, techniques, sequences or procedures. If the Contractor determines that such means, methods, techniques, sequences or procedures may not be safe, the Contractor shall give timely written notice to the Owner and Engineer and shall not proceed with that portion of the Work without further written instructions from the Engineer. If the Contractor is then instructed to proceed with the required means, methods, techniques, sequences or procedures without acceptance of changes proposed by the Contractor, the Owner shall be solely responsible for any resulting loss or damage.

3.3.2 The Contractor shall be responsible to the Owner for acts and omissions of the Contractor's employees, Subcontractors and their agents and employees, and other persons or entities performing portions of the Work for or on behalf of the Contractor or any of its Subcontractors.

3.3.3 The Contractor shall be responsible for inspection of portions of Work already performed to determine that such portions are in proper condition to receive subsequent Work.

3.4 LABOR AND MATERIALS

3.4.1 Unless otherwise provided in the Contract Documents, the Contractor shall provide and pay for labor, materials, equipment, tools, construction equipment and machinery, water, heat, utilities, transportation, and other facilities and services necessary for proper

execution and completion of the Work, whether temporary or permanent and whether or not incorporated or to be incorporated in the Work.

3.4.2 The Contractor may make substitutions only with the consent of the Owner, after evaluation by the Engineer and in accordance with a Change Order.

3.4.3 The Contractor shall enforce strict discipline and good order among the Contractor's employees and other persons carrying out the Contract. The Contractor shall not permit employment of unfit persons or persons not skilled in tasks assigned to them.

3.5 WARRANTY

3.5.1 The Contractor warrants to the Owner and Engineer that materials and equipment furnished under the Contract will be of good quality and new unless otherwise required or permitted by the Contract Documents, that the Work will be free from defects not inherent in the quality required or permitted, and that the Work will conform to the requirements of the Contract Documents. Work not conforming to these requirements, including substitutions not properly approved and authorized, may be considered defective. The Contractor's warranty excludes remedy for damage or defect caused by abuse, modifications not executed by the Contractor, improper or insufficient maintenance, improper operation, or normal wear and tear and normal usage. If required by the Engineer, the Contractor shall furnish satisfactory evidence as to the kind and quality of materials and equipment.

3.6 TAX

3.6.1 The Contractor shall pay sales, consumer, use and similar taxes for the Work provided by the Contractor which are legally enacted when bids are received or negotiations concluded, whether or not yet effective or merely scheduled to go into effect.

3.7 PERMITS, FEES AND NOTICES

3.7.1 Unless otherwise provided in the Contract Documents, the Contractor shall secure and pay for the building permit and other permits and governmental fees, licenses and inspections necessary for proper execution and completion of the Work which are customarily secured after execution of the Contract and which are legally required when bids are received or negotiations concluded.

3.7.2 The Contractor shall comply with and give notices required by laws, ordinances, rules, regulations and lawful orders of public authorities applicable to performance of the Work.

3.7.3 It is not the Contractor's responsibility to ascertain that the Contract Documents are in accordance with applicable laws, statutes, ordinances, building codes, and rules and regulations. However, if the Contractor observes that portions of the Contract Documents are at variance therewith, the Contractor shall promptly notify the Engineer and Owner in writing, and necessary changes shall be accomplished by appropriate Modification.

3.7.4 If the Contractor performs Work knowing it to be contrary to laws, statutes, ordinances, building codes, and rules and regulations without such notice to the Engineer and Owner, the Contractor shall assume appropriate responsibility for such Work and shall bear the costs attributable to correction.

3.8 ALLOWANCES

3.8.1 The Contractor shall include in the Contract Sum all allowances stated in the Contract Documents. Items covered by allowances shall be supplied for such amounts and by such persons or entities as the Owner may direct, but the Contractor shall not be required to employ persons or entities to whom the Contractor has reasonable objection.

3.8.2 Unless otherwise provided in the Contract Documents:

- 1 allowances shall cover the cost to the Contractor of materials and equipment delivered at the site and all required taxes, less applicable trade discounts;
- 2 Contractor's costs for unloading and handling at the site, labor, installation costs, overhead, profit and other expenses contemplated for stated allowance amounts shall be included in the Contract Sum but not in the allowances;
- 3 whenever costs are more than or less than allowances, the Contract Sum shall be adjusted accordingly by Change Order. The amount of the Change Order shall reflect (1) the difference between actual costs and the allowances under Clause **3.8.2.1** and (2) changes in Contractor's costs under Clause **3.8.2.2**.

3.8.3 Materials and equipment under an allowance shall be selected by the Owner in sufficient time to avoid delay in the Work.

3.9 SUPERINTENDENT

3.9.1 The Contractor shall employ competent superintendent and necessary assistants who shall be in attendance at the Project site during performance of the Work. The superintendent shall represent the Contractor, and communications given to the superintendent shall be as binding as if given to the Contractor. Important communications shall be confirmed in writing. Other communications shall be similarly confirmed on written request in each case.

3.10 CONTRACTOR'S CONSTRUCTION SCHEDULES

3.10.1 The Contractor, promptly after being awarded the Contract, shall prepare and submit for prior approval by Owner and Engineer Contractor's construction schedule for the Work. The schedule shall not exceed time limits current under the Contract Documents, shall be revised at appropriate intervals as required by the conditions of the Work and Project, shall be related to the entire Project to the extent required by the Contract Documents, and shall provide for expeditious and practicable execution of the Work.

3.10.2 The Contractor shall prepare and keep current, for the Engineer's approval, a schedule of submittals which is coordinated with the Contractor's construction schedule and allows the Engineer reasonable time to review submittals.

3.10.3 The Contractor shall perform the Work in general accordance with the most recent schedules submitted to the Owner and Engineer.

3.11 DOCUMENTS AND SAMPLES AT THE SITE

3.11.1 The Contractor shall maintain at the site for the Owner one record copy of the Drawings, Specifications, Addenda, Change Orders and other Modifications, in good order and marked currently to record field changes and selections made during construction, and one record copy of approved Shop Drawings, Product Data, Samples and similar required submittals. These shall be available to the Engineer and shall be delivered to the Engineer for submittal to the Owner upon completion of the Work.

3.12 SHOP DRAWINGS, PRODUCT DATA AND SAMPLES

3.12.1 Shop Drawings are drawings, diagrams, schedules and other data specially prepared for the Work by the Contractor or a Subcontractor, Sub-Subcontractor, manufacturer, supplier or distributor to illustrate some portion of the Work.

3.12.2 Product Data are illustrations, standard schedules, performance charts, instructions, brochures, diagrams and other information furnished by the Contractor to illustrate materials or equipment for some portion of the Work.

- 3.12.3** Samples are physical examples which illustrate materials, equipment or workmanship and establish standards by which the Work will be judged.
- 3.12.4** Shop Drawings, Product Data, Samples, and similar submittals are not Contract Documents. The purpose of their submittal is to demonstrate for those portions of the Work for which submittals are required by the Contract Documents the way by which the Contractor proposes to conform to the information given and the design concept expressed in the Contract Documents. Review by the Engineer is subject to the limitations of Subparagraph 4.2.7. Informational submittals upon which the Engineer is not expected to take responsive action may be so identified in the Contract Documents. Submittals which are not required by the Contract Documents may be returned by the Engineer without action.
- 3.12.5** The Contractor shall review for compliance with the Contract Documents, approve and submit to the Engineer Shop Drawings, Product Data, Samples, and similar submittals required by the Contract Documents with reasonable promptness and in such sequence as to cause no delay in the Work or in the activities of the Owner or of separate Contractors. Submittals which are not marked as reviewed for compliance with the Contract Documents and approved by the Contractor may be returned by the Engineer without action.
- 3.12.6** By approving and submitting Shop Drawings, Product Data, Samples, and similar submittals, the Contractor represents that the Contractor has determined and verified materials, field measurements and field construction criteria related thereto, or will do so, and has checked and coordinated the information contained within such submittals with the requirements of the Work and of the Contract Documents.
- 3.12.7** The Contractor shall perform no portion of the Work for which the Contract Documents require submittal and review of Shop Drawings, Product Data, Samples, or similar submittals until the respective submittal has been approved by the Engineer.
- 3.12.8** The Work shall be in accordance with approved submittals except that the Contractor shall not be relieved of responsibility for deviations from requirements of the Contract Documents by the Engineer's approval of Shop Drawings, Product Data, Samples, or similar submittals unless the Contractor has specifically informed the Engineer in writing of such deviation at the time of submittal and (1) the Engineer has given written approval to the specific deviation as a minor change in the Work, or (2) a Change Order or Construction Change Directive has been issued authorizing the deviation. The Contractor shall not be relieved of responsibility for errors or omissions in Shop Drawings, Product Data, Samples, or similar submittals by the Engineer's approval thereof.
- 3.12.9** The Contractor shall direct specific attention, in writing or on resubmitted Shop Drawings, Product Data, Samples, or similar submittals, to revisions other than those requested by the Engineer on previous submittals. In the absence of such written notice the Engineer's approval of a resubmission shall not apply to such revisions.
- 3.12.10** The Contractor shall not be required to provide professional services which constitute the practice of Engineerure or engineering unless such services are specifically required by the Contract Documents for a portion of the Work or unless the Contractor needs to provide such services in order to carry out the Contractor's responsibilities for construction means, methods, techniques, sequences and procedures. The Contractor shall not be required to provide professional services in violation of applicable law. If professional design services

or certifications by a design professional related to systems, materials or equipment are specifically required of the Contractor by the Contract Documents, the Owner and the Engineer will specify all performance and design criteria that such services must satisfy. The Contractor shall cause such services or certifications to be provided by a properly licensed design professional, whose signature and seal shall appear on all drawings, calculations, specifications, certifications, Shop Drawings and other submittals prepared by such professional. Shop Drawings and other submittals related to the Work designed or certified by such professional, if prepared by others, shall bear such professional's written approval when submitted to the Engineer. The Owner and the Engineer shall be entitled to rely upon the adequacy, accuracy and completeness of the services, certifications or approvals performed by such design professionals, provided the Owner and Engineer have specified to the Contractor all performance and design criteria that such services must satisfy. Pursuant to this Subparagraph **3.12.10**, the Engineer will review, approve or take other appropriate action on submittals only for the limited purpose of checking for conformance with information given and the design concept expressed in the Contract Documents. The Contractor shall not be responsible for the adequacy of the performance or design criteria required by the Contract Documents.

3.13 USE OF SITE

3.13.1 The Contractor shall confine operations at the site to areas permitted by law, ordinances, permits and the Contract Documents and shall not unreasonably encumber the site with materials or equipment.

3.14 CUTTING AND PATCHING

3.14.1 The Contractor shall be responsible for cutting, fitting or patching required to complete the Work or to make its parts fit together properly.

3.14.2 The Contractor shall not damage or endanger a portion of the Work or fully or partially completed construction of the Owner or separate Contractors by cutting, patching or otherwise altering such construction, or by excavation. The Contractor shall not cut or otherwise alter such construction by the Owner or a separate Contractor except with written consent of the Owner and of such separate Contractor; such consent shall not be unreasonably withheld. The Contractor shall not unreasonably withhold from the Owner or a separate Contractor the Contractor's consent to cutting or otherwise altering the Work.

3.15 CLEANING UP

3.15.1 The Contractor shall keep the premises and surrounding area free from accumulation of waste materials or rubbish caused by operations under the Contract. At completion of the Work, the Contractor shall remove from and about the Project waste materials, rubbish, the Contractor's tools, construction equipment, machinery and surplus materials.

3.15.2 If the Contractor fails to clean up as provided in the Contract Documents, the Owner may do so and the cost thereof shall be charged to the Contractor.

3.16 ACCESS TO WORK

3.16.1 The Contractor shall provide the Owner and Engineer access to the Work in preparation and progress wherever located.

3.17 ROYALTIES, PATENTS AND COPYRIGHTS

3.17.1 The Contractor shall pay all royalties and license fees. The Contractor shall defend suits or claims for infringement of copyrights and patent rights and shall hold the Owner and Engineer harmless from loss on account thereof, but shall not be responsible for such

defense or loss when a particular design, process or product of a particular manufacturer or manufacturers is required by the Contract documents or where the copyright violations are contained in Drawings, Specifications or other documents prepared by the Owner or Engineer. However, if the Contractor has reason to believe that the required design, process or product is an infringement of a copyright or a patent, the Contractor shall be responsible for such loss unless such information is promptly furnished to the Engineer.

3.18 INDEMNIFICATION

3.18.1 To the fullest extent permitted by law and to the extent claims, damages, losses or expenses are not covered by Project Management Protective Liability insurance purchased by the Contractor in accordance with Article **11**, the Contractor shall indemnify and hold harmless the Owner, Engineer, Engineer's consultants, and agents and employees of any of them from and against claims, damages, losses and expenses, including but not limited to attorneys' fees, arising out of or resulting from performance of the Work, provided that such claim, damage, loss or expense is attributable to bodily injury, sickness, disease or death, or to injury to or destruction of tangible property (other than the Work itself), but only to the extent caused by the negligent acts or omissions of the Contractor, a Subcontractor, anyone directly or indirectly employed by them or anyone for whose acts they may be liable, regardless of whether or not such claim, damage, loss or expense is caused in part by a party indemnified hereunder. Such obligation shall not be construed to negate, abridge, or reduce other rights or obligations of indemnity which would otherwise exist as to a party or person described in this Paragraph **3.18**.

3.18.2 In claims against any person or entity indemnified under this Paragraph **3.18** by an employee of the Contractor, a Subcontractor, anyone directly or indirectly employed by them or anyone for whose acts they may be liable, the indemnification obligation under Subparagraph **3.18.1** shall not be limited by a limitation on amount or type of damages, compensation or benefits payable by or for the Contractor or a Subcontractor under workers' compensation acts, disability benefit acts or other employee benefit acts.

ARTICLE 4: ADMINISTRATION OF THE CONTRACT

4.1 ENGINEER

4.1.1 The Engineer is the person lawfully licensed to practice Engineerure or an entity lawfully practicing Engineerure identified as such in the Agreement and is referred to throughout the Contract Documents as if singular in number. The term "Engineer" means the Engineer or the Engineer's authorized representative.

4.1.2 Duties, responsibilities and limitations of authority of the Engineer as set forth in the Contract Documents shall not be restricted, modified or extended without written consent of the Owner, Contractor and Engineer. Consent shall not be unreasonably withheld.

4.1.3 If the employment of the Engineer is terminated, the Owner shall employ a new Engineer against whom the Contractor has no reasonable objection and whose status under the Contract Documents shall be that of the former Engineer.

4.2 ENGINEER'S ADMINISTRATION OF THE CONTRACT

4.2.1 The Engineer will provide administration of the Contract as described in the Contract Documents, and will be an Owner's representative (1) during construction, (2) until final payment is due and (3) with the Owner's concurrence, from time to time during the one-year period for correction of Work described in Paragraph **12.2**. The Engineer will have authority to act on behalf of the Owner only to the extent provided in the Contract

Documents, unless otherwise modified in writing in accordance with other provisions of the Contract.

- 4.2.2** The Engineer, as a representative of the Owner, will visit the site at intervals appropriate to the stage of the Contractor's operations (1) to become generally familiar with and to keep the Owner informed about the progress and quality of the portion of the Work completed, (2) to endeavor to guard the Owner against defects and deficiencies in the Work, and (3) to determine in general if the Work is being performed in a manner indicating that the Work, when fully completed, will be in accordance with the Contract Documents. However, the Engineer will not be required to make exhaustive or continuous on-site inspections to check the quality or quantity of the Work. The Engineer will neither have control over or charge of, nor be responsible for, the construction means, methods, techniques, sequences or procedures, or for the safety precautions and programs in connection with the Work, since these are solely the Contractor's rights and responsibilities under the Contract Documents, except as provided in Subparagraph **3.3.1**.
- 4.2.3** The Engineer will not be responsible for the Contractor's failure to perform the Work in accordance with the requirements of the Contract Documents. The Engineer will not have control over or charge of and will not be responsible for acts or omissions of the Contractor, Subcontractors, or their agents or employees, or any other persons or entities performing portions of the Work.
- 4.2.4** Communications Facilitating Contract Administration. Except as otherwise provided in the Contract Documents or when direct communications have been specially authorized, the Owner and Contractor shall endeavor to communicate with each other through the Engineer about matters arising out of or relating to the Contract. Communications by and with the Engineer's consultants shall be through the Engineer. Communications by and with Subcontractors and material suppliers shall be through the Contractor. Communications by and with separate Contractors shall be through the Owner.
- 4.2.5** Based on the Engineer's evaluations of the Contractor's Applications for Payment, the Engineer will review and certify the amounts due the Contractor and will issue Certificates for Payment in such amounts.
- 4.2.6** The Engineer will have authority to reject Work that does not conform to the Contract Documents. Whenever the Engineer considers it necessary or advisable, the Engineer will have authority to require inspection or testing of the Work in accordance with Subparagraphs **13.5.2** and **13.5.3**, whether or not such Work is fabricated, installed or completed. However, neither this authority of the Engineer nor a decision made in good faith either to exercise or not to exercise such authority shall give rise to a duty or responsibility of the Engineer to the Contractor, Subcontractors, material and equipment suppliers, their agents or employees, or other persons or entities performing portions of the Work.
- 4.2.7** The Engineer will review and approve or take other appropriate action upon the Contractor's submittals such as Shop Drawings, Product Data and Samples, but only for the limited purpose of checking for conformance with information given and the design concept expressed in the Contract Documents. The Engineer's action will be taken with such reasonable promptness as to cause no delay in the Work or in the activities of the Owner, Contractor or separate Contractors, while allowing sufficient time in the Engineer's professional judgment to permit adequate review. Review of such submittals is not

conducted for the purpose of determining the accuracy and completeness of other details such as dimensions and quantities, or for substantiating instructions for installation or performance of equipment or systems, all of which remain the responsibility of the Contractor as required by the Contract Documents. The Engineer's review of the Contractor's submittals shall not relieve the Contractor of the obligations under Paragraphs **3.3, 3.5 and 3.12**. The Engineer's review shall not constitute approval of safety precautions or, unless otherwise specifically stated by the Engineer, of any construction means, methods, techniques, sequences or procedures. The Engineer's approval of a specific item shall not indicate approval of an assembly of which the item is a component.

- 4.2.8** The Engineer will prepare Change Orders and Construction Change Directives, and may authorize minor changes in the Work as provided in Paragraph **7.4**.
- 4.2.9** The Engineer will conduct inspections to determine the date or dates of Substantial Completion and the date of final completion, will receive and forward to the Owner, for the Owner's review and records, written warranties and related documents required by the Contract and assembled by the Contractor, and will issue a final Certificate for Payment upon compliance with the requirements of the Contract Documents.
- 4.2.10** If the Owner and Engineer agree, the Engineer will provide one or more project representatives to assist in carrying out the Engineer's responsibilities at the site. The duties, responsibilities and limitations of authority of such project representatives shall be as set forth in an exhibit to be incorporated in the Contract Documents.
- 4.2.11** The Engineer will interpret and decide matters concerning performance under, and requirements of, the Contract Documents on written request of either the Owner or Contractor. The Engineer's response to such requests will be made in writing within any time limits agreed upon or otherwise with reasonable promptness. If no agreement is made concerning the time within which interpretations required of the Engineer shall be furnished in compliance with this Paragraph **4.2**, then delay shall not be recognized on account of failure by the Engineer to furnish such interpretations until **15** days after written request is made for them.
- 4.2.12** Interpretations and decisions of the Engineer will be consistent with the intent of and reasonably inferable from the Contract Documents and will be in writing or in the form of drawings. When making such interpretations and initial decisions, the Engineer will endeavor to secure faithful performance by both Owner and Contractor, will not show partiality to either and will not be liable for results of interpretations or decisions so rendered in good faith.
- 4.2.13** The Engineer's decisions on matters relating to aesthetic effect will be final if consistent with the intent expressed in the Contract Documents.

4.3 CLAIMS AND DISPUTES

- 4.3.1** Definition. A Claim is a demand or assertion by one of the parties seeking, as a matter of right, adjustment or interpretation of Contract terms, payment of money, extension of time or other relief with respect to the terms of the Contract. The term "Claim" also includes other disputes and matters in question between the Owner and Contractor arising out of or relating to the Contract. Claims must be initiated by written notice. The responsibility to substantiate claims shall rest with the party making the Claim.

- 4.3.2 Time Limits on Claims.** Claims by either party must be initiated within **21** days after occurrence of the event giving rise to such Claim or within **21** days after the claimant first recognizes the condition giving rise to the Claim, whichever is later. Claims must be initiated by written notice to the Engineer and the other party.
- 4.3.3 Continuing Contract Performance.** Pending final resolution of a Claim except as otherwise agreed in writing or as provided in Subparagraph **9.7.1** and Article **14**, the Contractor shall proceed diligently with performance of the Contract and the Owner shall continue to make payments in accordance with the Contract Documents.
- 4.3.4 Claims for Concealed or Unknown Conditions.** If conditions are encountered at the site which are (1) subsurface or otherwise concealed physical conditions which differ materially from those indicated in the Contract Documents or (2) unknown physical conditions of an unusual nature, which differ materially from those ordinarily found to exist and generally recognized as inherent in construction activities of the character provided for in the Contract Documents, then notice by the observing party shall be given to the other party promptly before Conditions are disturbed and in no event later than **21** days after first observance of the conditions. The Engineer will promptly investigate such conditions and, if they differ materially and cause an increase or decrease in the Contractor's cost of, or time required for, performance of any part of the Work, will recommend an equitable adjustment in the Contract Sum or Contract Time, or both. If the Engineer determines that the conditions at the site are not materially different from those indicated in the Contract Documents and that no change in the terms of the Contract is justified, the Engineer shall so notify the Owner and Contractor in writing, stating the reasons. Claims by either party in opposition to such determination must be made within **21** days after the Engineer has given notice of the decision. If the conditions encountered are materially different, the Contract Sum and Contract Time shall be equitably adjusted, but if the Owner and Contractor cannot agree on an adjustment in the Contract Sum or Contract Time, the adjustment shall be referred to the Engineer for initial determination, subject to further proceedings pursuant to Paragraph **4.4**.
- 4.3.5 Claims for Additional Cost.** If the Contractor wishes to make Claim for an increase in the Contract Sum, written notice as provided herein shall be given before proceeding to execute the Work. Prior notice is not required for Claims relating to an emergency endangering life or property arising under Paragraph **10.6**.
- 4.3.6** If the Contractor believes additional cost is involved for reasons including but not limited to (1) a written interpretation from the Engineer, (2) an order by the Owner to stop the Work where the Contractor was not at fault, (3) a written order for a minor change in the Work issued by the Engineer, (4) failure of payment by the Owner, (5) termination of the Contract by the Owner, (6) Owner's suspension or (7) other reasonable grounds, Claim shall be filed in accordance with this Paragraph **4.3**.
- 4.3.7 CLAIMS FOR ADDITIONAL TIME**
- 4.3.7.1** If the Contractor wishes to make Claim for an increase in the Contract Time, written notice as provided herein shall be given. The Contractor's Claim shall include an estimate of cost and of probable effect of delay on progress of the Work. In the case of a continuing delay only one Claim is necessary.
- 4.3.7.2** If adverse weather conditions are the basis for a Claim for additional time, such Claim shall be documented by data substantiating that weather conditions were

abnormal for the period of time, could not have been reasonably anticipated and had an adverse effect on the scheduled construction.

4.3.8 Injury or Damage to Person or Property. If either party to the Contract suffers injury or damage to person or property because of an act or omission of the other party, or of others for whose acts such party is legally responsible, written notice of such injury or damage, whether or not insured, shall be given to the other party within a reasonable time not exceeding **21** days after discovery. The notice shall provide sufficient detail to enable the other party to investigate the matter.

4.3.9 If unit prices are stated in the Contract Documents or subsequently agreed upon, and if quantities originally contemplated are materially changed in a proposed Change Order or Construction Change Directive so that application of such unit prices to quantities of Work proposed will cause substantial inequity to the Owner or Contractor, the applicable unit prices shall be equitably adjusted.

4.3.10 Claims for Consequential Damages. The Contractor and Owner waive Claims against each other for consequential damages arising out of or relating to this Contract. This mutual waiver includes:

- 1 damages incurred by the Owner for rental expenses, for losses of use, income, profit, financing, business and reputation, and for loss of management or employee productivity or of the services of such persons; and
- 2 damages incurred by the Contractor for principal office expenses including the compensation of personnel stationed there, for losses of financing, business and reputation, and for loss of profit except anticipated profit arising directly from the Work.

This mutual waiver is applicable, without limitation, to all consequential damages due to either party's termination in accordance with Article **14**. Nothing contained in this Subparagraph **4.3.10** shall be deemed to preclude an award of liquidated direct damages, when applicable, in accordance with the requirements of the Contract Documents.

4.4 RESOLUTION OF CLAIMS AND DISPUTES

4.4.1 The Engineer will review Claims and take one or more of the following preliminary actions within ten days of receipt of a Claim: (1) request additional supporting data from the claimant; (2) submit a schedule to the parties indicating when the Engineer expects to take action; (3) reject the Claim in whole or in part stating reasons for rejection; (4) recommend approval of the Claim by the other party; or (5) suggest a compromise. The Engineer may also, but is not obligated to, notify the surety, if any, of the nature and amount of the Claim.

4.4.2 If a Claim has been resolved, the Engineer will prepare or obtain appropriate documentation.

4.4.3 If a Claim has not been resolved, the party making the Claim shall, within ten days after the Engineer's preliminary response take one or more of the following actions: (1) submit additional supporting data requested by the Engineer; (2) modify the initial Claim; or (3) notify the Engineer that the initial Claim stands.

4.4.4 If a Claim has not been resolved after consideration of the foregoing and of further evidence presented by the parties or requested by the Engineer, the Engineer will notify the parties in writing that the Engineer's decision will be made within seven days, which

decision shall be final and binding on the parties. Upon expiration of such time period, the Engineer will render to the parties the Engineer's written decision relative to the Claim, including any change in the Contract Sum or Contract Time or both. If there is a surety and there appears to be a possibility of a Contractor's default, the Engineer may, but is not obligated to, notify the surety and request the surety's assistance in resolving the controversy.

ARTICLE 5: SUBCONTRACTORS

5.1 DEFINITIONS

5.1.1 A Subcontractor is a person or entity who has a direct contract with the Contractor to perform a portion of the Work at the site. The term "Subcontractor" is referred to throughout the Contract Documents as if singular in number and means a Subcontractor or an authorized representative of the Subcontractor. The term "Subcontractor" does not include a separate Contractor or Subcontractors of a separate Contractor.

5.1.2 A Sub-Subcontractor is a person or entity who has a direct or indirect contract with a Subcontractor to perform a portion of the Work at the site. The term "Sub-Subcontractor" is referred to throughout the Contract Documents as if singular in number and means a Sub-Subcontractor or an authorized representative of the Sub-Subcontractor.

5.2 AWARD OF SUBCONTRACTS AND OTHER CONTRACTS FOR PORTIONS OF THE WORK

5.2.1 Unless otherwise stated in the Contract Documents or the bidding requirements, the Contractor, as soon as practicable after award of the Contract, shall furnish in writing to the Owner through the Engineer the names of persons or entities (including those who are to furnish materials or equipment fabricated to a special design) proposed for each principal portion of the Work. The Engineer will promptly reply to the Contractor in writing stating whether or not the Owner or the Engineer, after due investigation, has reasonable objection to any such proposed person or entity. Failure of the Owner or Engineer to reply promptly shall constitute notice of no reasonable objection.

5.2.2 The Contractor shall not contract with a proposed person or entity to whom the Owner or Engineer has made reasonable and timely objection. The Contractor shall not be required to contract with anyone to whom the Contractor has made reasonable objection.

5.2.3 If the Owner or Engineer has reasonable objection to a person or entity proposed by the Contractor, the Contractor shall propose another to whom the Owner or Engineer has no reasonable objection. If the proposed but rejected Subcontractor was reasonably capable of performing the Work, the Contract Sum and Contract Time shall be increased or decreased by the difference, if any, occasioned by such change, and an appropriate Change Order shall be issued before commencement of the substitute Subcontractor's Work. However, no increase in the Contract Sum or Contract Time shall be allowed for such change unless the Contractor has acted promptly and responsively in submitting names as required.

5.2.4 The Contractor shall not change a Subcontractor, person or entity previously selected if the Owner or Engineer makes reasonable objection to such substitute.

5.3 SUBCONTRACTUAL RELATIONS

5.3.1 By appropriate agreement, written where legally required for validity, the Contractor shall require each Subcontractor, to the extent of the Work to be performed by the Subcontractor, to be bound to the Contractor by terms of the Contract Documents, and to assume toward the Contractor all the obligations and responsibilities, including the responsibility for safety of the Subcontractor's Work, which the Contractor, by these Documents, assumes toward

the Owner and Engineer. Each subcontract agreement shall preserve and protect the rights of the Owner and Engineer under the Contract Documents with respect to the Work to be performed by the Subcontractor so that subcontracting thereof will not prejudice such rights, and shall allow to the Subcontractor, unless specifically provided otherwise in the subcontract agreement, the benefit of all rights, remedies and redress against the Contractor that the Contractor, by the Contract Documents, has against the Owner. Where appropriate, the Contractor shall require each Subcontractor to enter into similar agreements with Sub-Subcontractors. The Contractor shall make available to each proposed Subcontractor, prior to the execution of the subcontract agreement, copies of the Contract Documents to which the Subcontractor will be bound, and, upon written request of the Subcontractor, identify to the Subcontractor terms and conditions of the proposed subcontract agreement which may be at variance with the Contract Documents. Subcontractors will similarly make copies of applicable portions of such documents available to their respective proposed Sub-Subcontractors.

5.4 CONTINGENT ASSIGNMENT OF SUBCONTRACTS

5.4.1 Each subcontract agreement for a portion of the Work is assigned by the Contractor to the Owner provided that:

- 1 assignment is effective only after termination of the Contract by the Owner for cause pursuant to Paragraph **14.2** and only for those subcontract agreements which the Owner accepts by notifying the Subcontractor and Contractor in writing; and
- 2 assignment is subject to the prior rights of the surety, if any, obligated under bond relating to the Contract.

5.4.2 Upon such assignment, if the Work has been suspended for more than **30** days, the Subcontractor's compensation shall be equitably adjusted for increases in cost resulting from the suspension.

ARTICLE 6: CONSTRUCTION BY OWNER OR BY SEPARATE CONTRACTORS

6.1 OWNER'S RIGHT TO PERFORM CONSTRUCTION AND TO AWARD SEPARATE CONTRACTS

6.1.1 The Owner reserves the right to perform construction or operations related to the Project with the Owner's own forces, and to award separate contracts in connection with other portions of the Project or other construction or operations on the site under Conditions of the Contract identical or substantially similar to these including those portions related to insurance and waiver of subrogation. If the Contractor claims that delay or additional cost is involved because of such action by the Owner, the Contractor shall make such Claim as provided in Paragraph **4.3**.

6.1.2 When separate contracts are awarded for different portions of the Project or other construction or operations on the site, the term "Contractor" in the Contract Documents in each case shall mean the Contractor who executes each separate Owner-Contractor Agreement.

6.1.3 The Owner shall provide for coordination of the activities of the Owner's own forces and of each separate Contractor with the Work of the Contractor, who shall cooperate with them. The Contractor shall participate with other separate Contractors and the Owner in reviewing their construction schedules when directed to do so. The Contractor shall make any revisions to the construction schedule deemed necessary after a joint review and mutual agreement. The construction schedules shall then constitute the schedules to be used by the Contractor, separate Contractors and the Owner until subsequently revised.

6.1.4 Unless otherwise provided in the Contract Documents, when the Owner performs construction or operations related to the Project with the Owner's own forces, the Owner shall be deemed to be subject to the same obligations and to have the same rights which apply to the Contractor under the Conditions of the Contract, including, without excluding others, those stated in Article 3, this Article 6 and Articles 10, 11 and 12.

6.2 MUTUAL RESPONSIBILITY

6.2.1 The Contractor shall afford the Owner and separate Contractors reasonable opportunity for introduction and storage of their materials and equipment and performance of their activities, and shall connect and coordinate the Contractor's construction and operations with theirs as required by the Contract Documents.

6.2.2 If part of the Contractor's Work depends for proper execution or results upon construction or operations by the Owner or a separate Contractor, the Contractor shall, prior to proceeding with that portion of the Work, promptly report to the Engineer apparent discrepancies or defects in such other construction that would render it unsuitable for such proper execution and results. Failure of the Contractor so to report shall constitute an acknowledgment that the Owner's or separate Contractor's completed or partially completed construction is fit and proper to receive the Contractor's Work, except as to defects not then reasonably discoverable.

6.2.3 The Owner shall be reimbursed by the Contractor for costs incurred by the Owner which are payable to a separate Contractor because of delays, improperly timed activities or defective construction of the Contractor. The Owner shall be responsible to the Contractor for costs incurred by the Contractor because of delays, improperly timed activities, damage to the Work, or defective construction of a separate Contractor.

6.2.4 The Contractor shall promptly remedy damage wrongfully caused by the Contractor to completed or partially completed construction or to property of the Owner or separate Contractors as provided in Subparagraph 10.2.5.

6.2.5 The Owner and each separate Contractor shall have the same responsibilities for cutting and patching as are described for the Contractor in Subparagraph 3.14.

6.3 OWNER'S RIGHT TO CLEAN UP

6.3.1 If a dispute arises among the Contractor, separate Contractors and the Owner as to the responsibility under their respective contracts for maintaining the premises and surrounding area free from waste materials and rubbish, the Owner may clean up and the Engineer will allocate the cost among those responsible.

ARTICLE 7: CHANGES IN THE WORK

7.1 GENERAL

7.1.1 Changes in the Work may be accomplished after execution of the Contract, and without invalidating the Contract, by Change Order, Construction Change Directive or order for a minor change in the Work, subject to the limitations stated in this Article 7 and elsewhere in the Contract Documents.

7.1.2 A Change Order shall be based upon agreement among the Owner, Contractor and Engineer; a Construction Change Directive requires agreement by the Owner and Engineer and may or may not be agreed to by the Contractor; an order for a minor change in the Work may be issued by the Engineer alone.

7.1.3 Changes in the Work shall be performed under applicable provisions of the Contract Documents, and the Contractor shall proceed promptly, unless otherwise provided in the Change Order, Construction Change Directive or order for a minor change in the Work.

7.2 CHANGE ORDERS

7.2.1 A Change Order is a written instrument prepared by the Engineer and signed by the Owner, Contractor and Engineer, stating their agreement upon all of the following:

- 1 change in the Work;
- 2 the amount of the adjustment, if any, in the Contract Sum; and
- 3 the extent of the adjustment, if any, in the Contract Time.

7.2.2 Methods used in determining adjustments to the Contract Sum may include those listed in Subparagraph 7.3.3.

7.3 CONSTRUCTION CHANGE DIRECTIVES

7.3.1 A Construction Change Directive is a written order prepared by the Engineer and signed by the Owner and Engineer, directing a change in the Work prior to agreement on adjustment, if any, in the Contract Sum or Contract Time, or both. The Owner may by Construction Change Directive, without invalidating the Contract, order changes in the Work within the general scope of the Contract consisting of additions, deletions or other revisions, the Contract Sum and Contract Time being adjusted accordingly.

7.3.2 A Construction Change Directive shall be used in the absence of total agreement on the terms of a Change Order.

7.3.3 If the Construction Change directive provides for an adjustment to the Contract Sum, the adjustment shall be based on one of the following methods:

- 1 mutual acceptance of a lump sum properly itemized and supported by sufficient substantiating data to permit evaluation;
- 2 unit prices stated in the Contract Documents or subsequently agreed upon;
- 3 cost to be determined in a manner agreed upon by the parties and a mutually acceptable fixed or percentage fee; or
- 4 as provided in Subparagraph 7.3.6.

7.3.4 Upon receipt of a Construction Change Directive, the Contractor shall promptly proceed with the change in the Work involved and advise the Engineer of the Contractor's agreement or disagreement with the method, if any, provided in the Construction Change Directive for determining the proposed adjustment in the Contract Sum or Contract Time.

7.3.5 A Construction Change Directive signed by the Contractor indicates the agreement of the Contractor therewith, including adjustment in Contract Sum and Contract Time or the method for determining them. Such agreement shall be effective immediately and shall be recorded as a Change Order.

7.3.6 If the Contractor does not respond promptly or disagrees with the method for adjustment in the Contract Sum, the method and the adjustment shall be determined by the Engineer on the basis of reasonable expenditures and savings of those performing the Work attributable to the change, including, in case of an increase in the Contract Sum, a reasonable allowance for overhead and profit. In such case, and also under Clause 7.3.3.3, the Contractor shall keep and present, in such form as the Engineer may prescribe, an

itemized accounting together with appropriate supporting data. Unless otherwise provided in the Contract Documents, costs for the purposes of this Subparagraph 7.3.6 shall be limited to the following:

- 1 costs of labor, including social security, old age and unemployment insurance, fringe benefits required by agreement or custom, and workers' compensation insurance;
- 2 costs of materials, supplies and equipment, including cost of transportation, whether incorporated or consumed;
- 3 rental costs of machinery and equipment, exclusive of hand tools, whether rented from the Contractor or others;
- 4 costs of premiums for all bonds and insurance, permit fees, and sales, use or similar taxes related to the Work; and
- 5 additional costs of supervision and field office personnel directly attributable to the change.

7.3.7. The amount of credit to be allowed by the Contractor to the Owner for a deletion or change which results in a net decrease in the Contract Sum shall be actual net cost as confirmed by the Engineer. When both additions and credits covering related Work or substitutions are involved in a change, the allowance for overhead and profit shall be figured on the basis of net increase, if any, with respect to that change.

7.3.8 Pending final determination of the total cost of a Construction Change Directive to the Owner, amounts not in dispute for such changes in the Work shall be included in Applications for Payment accompanied by a Change Order indicating the parties' agreement with part or all of such costs. For any portion of such cost that remains in dispute, the Engineer will make an interim determination for purposes of monthly certification for payment for those costs. That determination of cost shall adjust the Contract Sum on the same basis as a Change Order, subject to the right of either party to disagree and assert a claim in accordance with Article 4.

7.3.9 When the Owner and Contractor agree with the determination made by the Engineer concerning the adjustments in the Contract Sum and Contract Time, or otherwise reach agreement upon the adjustments, such agreement shall be effective immediately and shall be recorded by preparation and execution of an appropriate Change Order.

7.4 MINOR CHANGES IN THE WORK

7.4.1 The Engineer will have authority to order minor changes in the Work not involving adjustment in the Contract Sum or extension of the Contract Time and not inconsistent with the intent of the Contract Documents. Such changes shall be effected by written order and shall be binding on the Owner and Contractor. The Contractor shall carry out such written orders promptly.

ARTICLE 8: TIME

8.1 DEFINITIONS

8.1.1 Unless otherwise provided, Contract Time is the period of time, including authorized adjustments, allotted in the Contract Documents for Substantial Completion of the Work.

8.1.2 The date of commencement of the Work is the date established in the Agreement. The date shall not be postponed by the failure to act of the Contractor or of persons or entities for whom the Contractor is responsible.

8.1.3 The date of Substantial Completion is the date certified by the Engineer in accordance with Paragraph **9.8**.

8.1.4 The term "day" as used in the Contract Documents shall mean calendar day unless otherwise specifically defined.

8.2 PROGRESS AND COMPLETION

8.2.1 Time limits stated in the Contract Documents are of the essence of the Contract. By executing the Agreement the Contractor confirms that the Contract Time is a reasonable period for performing the work.

8.2.2 The Contractor shall not knowingly, except by agreement or instruction of the Owner in writing, prematurely commence operations on the site or elsewhere prior to the effective date of insurance required by Article **11** to be furnished by the Contractor and Owner. The date of commencement of the Work shall not be changed by the effective date of such insurance. Unless the date of commencement is established by the Contract Documents or a notice to proceed given by the Owner, the Contractor shall notify the Owner in writing not less than five days or other agreed period before commencing the Work to permit the timely filing of mortgages, mechanic's liens and other security interests.

8.2.3 The Contractor shall proceed with the project expeditiously and continuously with adequate forces and shall achieve Substantial Completion within the Contract Time. Contractor shall progress with and maintain continuous construction even if construction is ahead of the approved construction schedule.

If the percentage dollar value of the completed work is 15% or more below the dollar value of work that should have been completed in accordance with the approved construction schedule, further payment under this contract to Contractor shall be suspended until the percentage dollar value of completed work is within 5% of the dollar value of work that should have been completed in accordance with the approved construction schedule.

8.3 DELAYS AND EXTENSIONS OF TIME

8.3.1 If the Contractor is delayed at any time in the commencement or progress of the Work by an act or neglect of the Owner or Engineer, or of an employee of either, or of a separate Contractor employed by the Owner, or by changes ordered in the Work, or by labor disputes, fire, unusual delay in deliveries; unavoidable casualties or other causes beyond the Contractor's control, then the Contract Time shall be extended by Change Order for such reasonable time as the Engineer may determine.

8.3.2 Claims relating to time shall be made in accordance with applicable provisions of Paragraph **4.3**.

ARTICLE 9: PAYMENTS AND COMPLETION

9.1 CONTRACT SUM

9.1.1 The Contract Sum is stated in the Agreement and, including authorized adjustments, is the total amount payable by the Owner to the Contractor for performance of the Work under the Contract Documents.

9.2 SCHEDULE OF VALUES

9.2.1 Before the first Application for Payment, the Contractor shall submit to the Engineer a schedule of values allocated to various portions of the Work, prepared in such form and supported by such data to substantiate its accuracy as the Engineer may require. This

schedule, unless objected to by the Engineer, shall be used as a basis for reviewing the Contractor's Applications for Payment.

9.3 APPLICATIONS FOR PAYMENT

9.3.1 At least ten days before the date established for each progress payment, the Contractor shall submit to the Engineer an itemized Application for Payment for operations completed in accordance with the schedule of values. Such application shall be notarized, if required, and supported by such data substantiating the Contractor's right to payment as the Owner or Engineer may require, such as copies of requisitions from Subcontractors and material suppliers, and reflecting retainage if provided for in the Contract Documents.

9.3.1.1 As provided in Subparagraph **7.3.8**, such applications may include requests for payment on account of changes in the Work which have been properly authorized by Construction Change Directives, or by interim determination of the Engineer, but not yet included in Change Orders.

9.3.1.2 Such applications may not include requests for payment for portions of the Work for which the Contractor does not intend to pay to a Subcontractor or material supplier, unless such Work has been performed by others whom the Contractor intends to pay.

9.3.2 Unless otherwise provided in the Contract Documents, payments shall be made on account of materials and equipment delivered and suitably stored at the site for subsequent incorporation in the Work. If approved in advance by the Owner, payment may similarly be made for materials and equipment suitably stored off the site at a location agreed upon in writing. Payment for materials and equipment stored on or off the site shall be conditioned upon compliance by the Contractor with procedures satisfactory to the Owner to establish the Owner's title to such materials and equipment or otherwise protect the Owner's interest, and shall include the costs of applicable insurance, storage and transportation to the site for such materials and equipment stored off the site.

9.3.3 The Contractor warrants that title to all Work covered by an Application for Payment will pass to the Owner no later than the time of payment. The Contractor further warrants that upon submittal of an Application for Payment all Work for which Certificates for Payment have been previously issued and payments received from the Owner shall, to the best of the Contractor's knowledge, information and belief, be free and clear of liens, claims, security interests or encumbrances in favor of the Contractor, Subcontractors, material suppliers, or other persons or entities making a claim by reason of having provided labor, materials and equipment relating to the Work.

9.4 CERTIFICATES FOR PAYMENT

9.4.1 The Engineer will, within seven days after receipt of the Contractor's Application for Payment, either issue to the Owner a Certificate for Payment, with a copy to the Contractor, for such amount as the Engineer determines is properly due, or notify the Contractor and Owner in writing of the Engineer's reasons for withholding certification in whole or in part as provided in Subparagraph **9.5.1**.

9.4.2 The issuance of a Certificate for Payment will constitute a representation by the Engineer to the Owner, based on the Engineer's evaluation of the Work and the data comprising the Application for Payment, that the Work has progressed to the point indicated and that, to the best of the Engineer's knowledge, information and belief, the quality of the Work is in accordance with the Contract Documents. The foregoing representations are subject to an evaluation of the Work for conformance with the Contract Documents upon Substantial Completion, to results of subsequent tests and inspections, to correction of minor deviations

from the Contract Documents prior to completion and to specific qualifications expressed by the Engineer. The issuance of a Certificate for Payment will further constitute a representation that the Contractor is entitled to payment in the amount certified. However, the issuance of a Certificate for Payment will not be a representation that the Engineer has (1) made exhaustive or continuous on-site inspections to check the quality or quantity of the Work, (2) reviewed construction means, methods, techniques, sequences or procedures, (3) reviewed copies of requisitions received from Subcontractors and material suppliers and other data requested by the Owner to substantiate the Contractor's right to payment, or (4) made examination to ascertain how or for what purpose the Contractor has used money previously paid on account of the Contract Sum.

9.5 DECISIONS TO WITHHOLD CERTIFICATION

9.5.1 The Engineer may withhold a Certificate for Payment in whole or in part, to the extent reasonably necessary to protect the Owner, if in the Engineer's opinion the representations to the Owner required by Subparagraph 9.4.2 cannot be made. If the Engineer is unable to certify payment in the amount of the Application, the Engineer will notify the Contractor and Owner as provided in Subparagraph 9.4.1. If the Contractor and Engineer cannot agree on a revised amount, the Engineer will promptly issue a Certificate for Payment for the amount for which the Engineer is able to make such representations to the Owner. The Engineer may also withhold a Certificate for Payment or, because of subsequently discovered evidence, may nullify the whole or a part of a Certificate for Payment previously issued, to such extent as may be necessary in the Engineer's opinion to protect the Owner from loss for which the Contractor is responsible, including loss resulting from acts and omissions described in Subparagraph 3.3.2, because of:

- 1 defective Work not remedied;
- 2 third party claims filed or reasonable evidence indicating probable filing of such claims unless security acceptable to the Owner is provided by the Contractor;
- 3 failure of the Contractor to make payments properly to Subcontractors or for labor, materials or equipment;
- 4 reasonable evidence that the Work cannot be completed for the unpaid balance of the Contract Sum;
- 5 damage to the Owner or another Contractor;
- 6 reasonable evidence that the Work will not be completed within the Contract Time, and that the unpaid balance would not be adequate to cover actual or liquidated damages for the anticipated delay; or
- 7 persistent failure to carry out the Work in accordance with the Contract Documents.

9.5.2 When the above reasons for withholding certification are removed, certification will be made for amounts previously withheld.

9.6 PROGRESS PAYMENTS

9.6.1 After the Engineer has issued a Certificate for Payment, the Owner shall make payment in the manner and within the time provided in the Contract Documents, and shall so notify the Engineer.

9.6.2 The Contractor shall promptly pay each Subcontractor, upon receipt of payment from the Owner, out of the amount paid to the Contractor on account of such Subcontractor's portion of the Work, the amount to which said Subcontractor is entitled, reflecting percentages actually retained from payments to the Contractor on account of such

Subcontractor's portion of the Work. The Contractor shall, by appropriate agreement with each Subcontractor, require each Subcontractor to make payments to Sub-Subcontractors in a similar manner.

- 9.6.3** The Engineer will, on request, furnish to a Subcontractor, if practicable, information regarding percentages of completion or amounts applied for by the Contractor and action taken thereon by the Engineer and Owner on account of portions of the Work done by such Subcontractor.
- 9.6.4** Neither the Owner nor Engineer shall have an obligation to pay or to see to the payment of money to a Subcontractor except as may otherwise be required by law.
- 9.6.5** Payment to material suppliers shall be treated in a manner similar to that provided in Subparagraphs **9.6.2**, **9.6.3** and **9.6.4**.
- 9.6.6** A Certificate for Payment, a progress payment, or partial or entire use or occupancy of the Project by the Owner shall not constitute acceptance of Work not in accordance with the Contract Documents.
- 9.6.7** Unless the Contractor provides the Owner with a payment bond in the full penal sum of the Contract Sum, payments received by the Contractor for Work properly performed by Subcontractors and suppliers shall be held by the Contractor for those Subcontractors or suppliers who performed Work or furnished materials, or both, under contract with the Contractor for which payment was made by the Owner. Nothing contained herein shall require money to be placed in a separate account and not commingled with money of the Contractor, shall create any fiduciary liability or tort liability on the part of the Contractor for breach of trust or shall entitle any person or entity to an award of punitive damages against the Contractor for breach of the requirements of this provision.

9.7 FAILURE OF PAYMENT

- 9.7.1** If the Engineer does not issue a Certificate for Payment, through no fault of the Contractor, within seven days after receipt of the Contractor's Application for Payment, or if the Owner does not pay the Contractor within seven days after the date established in the Contract Documents the amount certified by the Engineer or awarded by arbitration, then the Contractor may, upon seven additional days' written notice to the Owner and Engineer, stop the Work until payment of the amount owing has been received. The Contract Time shall be extended appropriately and the Contract Sum shall be increased by the amount of the Contractor's reasonable costs of shut-down, delay and start-up, plus interest as provided for in the Contract Documents.

9.8 SUBSTANTIAL COMPLETION

- 9.8.1** Substantial Completion is the stage in the progress of the Work when the Work or designated portion thereof is sufficiently complete in accordance with the Contract Documents so that the Owner can occupy or utilize the Work for its intended use.
- 9.8.2** When the Contractor considers that the Work, or a portion thereof which the Owner agrees to accept separately, is substantially complete, the Contractor shall prepare and submit to the Engineer a comprehensive list of items to be completed or corrected prior to final payment. Failure to include an item on such list does not alter the responsibility of the Contractor to complete all Work in accordance with the Contract Documents.
- 9.8.3** Upon receipt of the Contractor's list, the Engineer will make an inspection to determine whether the Work or designated portion thereof is substantially complete. If the Engineer's inspection discloses any item, whether or not included on the Contractor's list, which is not

sufficiently complete in accordance with the Contract Documents so that the Owner can occupy or utilize the Work or designated portion thereof for its intended use, the Contractor shall, before issuance of the Certificate of Substantial Completion, complete or correct such item upon notification by the Engineer. In such case, the Contractor shall then submit a request for another inspection by the Engineer to determine Substantial Completion.

9.8.4 When the Work or designated portion thereof is substantially complete, the Engineer will prepare a Certificate of Substantial Completion which shall establish the date of Substantial Completion, shall establish responsibilities of the Owner and Contractor for security, maintenance, heat, utilities, damage to the Work and insurance, and shall fix the time within which the Contractor shall finish all items on the list accompanying the Certificate, Warranties required by the Contract Documents shall commence on the date of Substantial Completion of the Work or designated portion thereof unless otherwise provided in the Certificate of Substantial Completion.

9.8.5 The Certificate of Substantial Completion shall be submitted to the Owner and Contractor for their written acceptance of responsibilities assigned to them in such Certificate. Upon such acceptance and consent of surety, if any, the Owner shall make payment of retainage applying to such Work or designated portion thereof. Such payment shall be adjusted for Work that is incomplete or not in accordance with the requirements of the Contract Documents.

9.9 PARTIAL OCCUPANCY OR USE

9.9.1 The Owner may occupy or use any completed or partially completed portion of the Work at any stage when such portion is designated by separate agreement with the Contractor, provided such occupancy or use is consented to by the insurer as required under Article 11 and authorized by public authorities having jurisdiction over the Work. Such partial occupancy or use may commence whether or not the portion is substantially complete, provided the Owner and Contractor have accepted in writing the responsibilities assigned to each of them for payments, retainage, if any, security, maintenance, heat, utilities, damage to the Work and insurance, and have agreed in writing concerning the period for correction of the Work and commencement of warranties required by the Contract Documents. When the Contractor considers a portion substantially complete, the Contractor shall prepare and submit a list to the Engineer as provided under Subparagraph 9.8.2. Consent of the Contractor to partial occupancy or use shall not be unreasonably withheld. The stage of the progress of the Work shall be determined by written agreement between the Owner and Contractor or, if no agreement is reached, by decision of the Engineer.

9.9.2 Immediately prior to such partial occupancy or use, the Owner, Contractor and Engineer shall jointly inspect the area to be occupied or portion of the Work to be used in order to determine and record the condition of the Work.

9.9.3 Unless otherwise agreed upon, partial occupancy or use of a portion or portions of the Work shall not constitute acceptance of Work not complying with the requirements of the Contract Documents.

9.10 FINAL COMPLETION AND FINAL PAYMENT

9.10.1 Upon receipt of written notice that the Work is ready for final inspection and acceptance and upon receipt of a final Application for Payment, the Engineer will promptly make such inspection and, when the Engineer finds the Work acceptable under the Contract Documents and the Contract fully performed, the Engineer will promptly issue a final Certificate for Payment stating that to the best of the Engineer's knowledge, information

and belief, and on the basis of the Engineer's on-site visits and inspections, the Work has been completed in accordance with terms and conditions of the Contract Documents and that the entire balance found to be due the Contractor and noted in the final Certificate is due and payable. The Engineer's final Certificate for Payment will constitute a further representation that conditions listed in Subparagraph 9.10.2 as precedent to the Contractor's being entitled to final payment have been fulfilled.

9.10.2 Neither final payment nor any remaining retained percentage shall become due until the Contractor submits to the Engineer (1) an affidavit that payrolls, bills for materials and equipment, and other indebtedness connected with the Work for which the Owner or the Owner's property might be responsible or encumbered (less amounts withheld by Owner) have been paid or otherwise satisfied, (2) a certificate evidencing that insurance required by the Contract Documents to remain in force after final payment is currently in effect and will not be canceled or allowed to expire until at least 30 days' prior written notice has been given to the Owner, (3) a written statement that the Contractor knows of no substantial reason that the insurance will not be renewable to cover the period required by the Contract Documents, (4) consent of surety, if any, to final payment and (5), if required by the Owner, other data establishing payment or satisfaction of obligations, such as receipts, releases and waivers of liens, claims, security interests or encumbrances arising out of the Contract, to the extent and in such form as may be designated by the Owner. If a Subcontractor refuses to furnish a release or waiver required by the Owner, the Contractor may furnish a bond satisfactory to the Owner to indemnify the Owner against such lien. If such lien remains unsatisfied after payments are made, the Contractor shall refund to the Owner all money that the Owner may be compelled to pay in discharging such lien, including all costs and reasonable attorneys' fees.

9.10.3 If, after Substantial Completion of the Work, final completion thereof is materially delayed through no fault of the Contractor or by issuance of Change Orders affecting final completion, and the Engineer so confirms, the Owner shall, upon application by the Contractor and certification by the Engineer, and without terminating the Contract, make payment of the balance due for that portion of the Work fully completed and accepted. If the remaining balance for Work not fully completed or corrected is less than retainage stipulated in the Contract Documents, and if bonds have been furnished, the written consent of surety to payment of the balance due for that portion of the Work fully completed and accepted shall be submitted by the Contractor to the Engineer prior to certification of such payment. Such payment shall be made under terms and conditions governing final payment, except that it shall not constitute a waiver of claims.

9.10.4 The making of final payment shall constitute a waiver of Claims by the Owner except those arising from:

- 1 liens, claims, security interests or encumbrances arising out of the Contract and unsettled;
- 2 failure of the Work to comply with the requirements of the Contract Documents; or
- 3 terms of special warranties required by the Contract Documents.

9.10.5 Acceptance of final payment by the Contractor, a Subcontractor or material supplier shall constitute a waiver of claims by that payee except those previously made in writing and identified by that payee as unsettled at the time of final Application for Payment.

ARTICLE 10: PROTECTION OF PERSONS AND PROPERTY

10.1 SAFETY PRECAUTIONS AND PROGRAMS

10.1.1 The Contractor shall be responsible for initiating, maintaining and supervising all safety precautions and programs in connection with the performance of the Contract.

10.2 SAFETY OF PERSONS AND PROPERTY

10.2.1 The Contractor shall take reasonable precautions for safety of, and shall provide reasonable protection to prevent damage, injury or loss to:

- 1 employees on the Work and other persons who may be affected thereby;
- 2 the Work and materials and equipment to be incorporated therein, whether in storage on or off the site, under care, custody or control of the Contractor or the Contractor's Subcontractors or Sub-Subcontractors; and
- 3 other property at the site or adjacent thereto, such as trees, shrubs, lawns, walks, pavements, roadways, structures and utilities not designated for removal, relocation or replacement in the course of construction.

10.2.2 The Contractor shall give notices and comply with applicable laws, ordinances, rules, regulations and lawful orders of public authorities bearing on safety of persons or property or their protection from damage, injury or loss.

10.2.3 The Contractor shall erect and maintain, as required by existing conditions and performance of the Contract, reasonable safeguards for safety and protection, including posting danger signs and other warnings against hazards, promulgating safety regulations and notifying owners and users of adjacent sites and utilities.

10.2.4 When use or storage of explosives or other hazardous materials or equipment or unusual methods are necessary for execution of the Work, the Contractor shall exercise utmost care and carry on such activities under supervision of properly qualified personnel.

10.2.5 The Contractor shall promptly remedy damage and loss (other than damage or loss insured under property insurance required by the Contract Documents) to property referred to in Clauses **10.2.1.2** and **10.2.1.3** caused in whole or in part by the Contractor, a Subcontractor, a Sub-Subcontractor, or anyone directly or indirectly employed by any of them, or by anyone for whose acts they may be liable and for which the Contractor is responsible under Clauses **10.2.1.2** and **10.2.1.3**, except damage or loss attributable to acts or omissions of the Owner or Engineer or anyone directly or indirectly employed by either of them, or by anyone for whose acts either of them may be liable, and not attributable to the fault or negligence of the Contractor. The foregoing obligations of the Contractor are in addition to the Contractor's obligations under Paragraph **3.18**.

10.2.6 The Contractor shall designate a responsible member of the Contractor's organization at the site whose duty shall be the prevention of accidents. This person shall be the Contractor's superintendent unless otherwise designated by the Contractor in writing to the Owner and Engineer.

10.2.7 The Contractor shall not load or permit any part of the construction or site to be loaded so as to endanger its safety.

10.3 EMERGENCIES

10.3.1 In an emergency affecting safety of persons or property, the Contractor shall act, at the Contractor's discretion, to prevent threatened damage, injury or loss. Additional

compensation or extension of time claimed by the Contractor on account of an emergency shall be determined as provided in Paragraph 4.3 and Article 7.

ARTICLE 11: INSURANCE AND BONDS

11.1 CONTRACTOR'S LIABILITY INSURANCE

11.1.1 The Contractor shall purchase from and maintain in a company or companies lawfully authorized to do business in the jurisdiction in which the Project is located such insurance as will protect the Contractor from claims set forth below which may arise out of or result from the Contractor's operations under the Contract and for which the Contractor may be legally liable, whether such operations be by the Contractor or by a Subcontractor or by anyone directly or indirectly employed by any of them, or by anyone for whose acts any of them may be liable.

- 1** claims under workers' compensation, disability benefit and other similar employee benefit acts which are applicable to the Work to be performed;
- 2** claims for damages because of bodily injury, occupational sickness or disease, or death of the Contractor's employees;
- 3** claims for damages because of bodily injury, sickness or disease, or death of any person other than the Contractor's employees;
- 4** claims for damages insured by usual personal injury liability coverage;
- 5** claims for damages, other than to the Work itself, because of injury to or destruction of tangible property, including loss of use resulting therefrom;
- 6** claims for damages because of bodily injury, death of a person or property damage arising out of ownership, maintenance or use of a motor vehicle;
- 7** claims for bodily injury or property damage arising out of completed operations; and
- 8** claims involving contractual liability insurance applicable to the Contractor's obligations under Paragraph 3.18.

11.1.2 The insurance required by Subparagraph 11.1.1 shall be written for not less than limits of liability specified in the Contract Documents or required by law, whichever coverage is greater. Coverages, whether written on an occurrence or claims-made basis, shall be maintained without interruption from date of commencement of the Work until date of final payment and termination of any coverage required to be maintained after final payment.

11.1.3 Certificates of insurance acceptable to the Owner shall be filed with the Owner prior to commencement of the Work. These certificates and the insurance policies required by this Paragraph 11.1 shall contain a provision that coverages afforded under the policies will not be canceled or allowed to expire until at least **30** days prior written notice has been given to the Owner. If any of the foregoing insurance coverages are required to remain in force after final payment and are reasonably available, an additional certificate evidencing continuation of such coverage shall be submitted with the final Application for Payment as required by Subparagraph 9.10.2. Information concerning reduction of coverage on account of revised limits or claims paid under the General Aggregate, or both, shall be furnished by the Contractor with reasonable promptness in accordance with the Contractor's information and belief.

11.2 INDEMNIFICATION AND INSURANCE

11.2.1. Contractor agrees to save harmless, indemnify, and defend Owner and its, agents, officers and employees from any and all claims, losses, penalties, interest, demands,

judgments, and costs of suit, including attorneys fees and paralegals' fees, for any expense, damage or liability incurred by any of them, whether for personal injury, death, property damage, direct or consequential damages, or economic loss, including environmental impairment, arising directly or indirectly on account of or in connection with the work done by Contractor under this agreement or by any person, firm or corporation (including but not limited to the Engineer/engineer) to whom any portion of the work is subcontracted by Contractor or resulting from the use by Contractor, or by any one for whom Contractor is legally liable, of any materials, tools, machinery or other property of Owner. Owner and Contractor agree the first \$100.00 of the contract amount paid by Owner to Contractor shall be given as separate consideration for this indemnification, and any other indemnification of Owner by Contractor provided for within the Contract Documents, the sufficiency of such separate consideration being acknowledged by Contractor by Contractor's acceptance and execution of the agreement. The Contractor's obligation shall not be limited by, or in any way to, any insurance coverage or by any provision in or exclusion or omission from any policy of insurance. The Contractor agrees to pay on behalf of Santa Rosa County, as well as provide a legal defense for the Owner, both of which will be done only if and when requested by the Owner, for all claims made. Such payment on the behalf of the Owner shall be in addition to any and all other legal remedies available to the Owner and shall not be considered to be the Owner's exclusive remedy.

11.2.2. Contractor shall obtain and carry, at all times during its performance under the Contract Documents, insurance of the types and in the amounts set forth in Article 11. All insurance policies shall be from responsible companies duly authorized to do business in the State of Florida and/or responsible risk retention group insurance companies or trusts which are registered with the State of Florida. Foreign or offshore insurance carriers are not acceptable for work under this contract unless admitted to the State of Florida. All commercial insurance carriers providing the Contractor with required insurance shall be "A" (excellent) rated with a minimum financial size category of "IX", according to the A. M. Best Key Rating Guide, latest edition. Within ten (10) calendar days after notice of award is received by Contractor and prior to the commencement of work, Contractor shall provide Owner with properly executed certificates of insurance to evidence Contractor's compliance with the insurance requirements of the Contract Documents. Said certificates of insurance shall be on forms approved by Owner, such as "Acord Form 25". The certificates of insurance shall be personally, manually signed by the authorized representatives of the insurance company/companies shown on the certificates of insurance, with proof that they are authorized representatives thereof. Certificates of insurance shall be mailed to Santa Rosa County Board of County Commissioners in care of: Daniel J. Schebler, County Administrator, 6495 Caroline Street, Suite D, Milton, Florida 32570. In addition, true and exact copies of all insurance policies required hereunder shall be provided to Owner, on a timely basis, when requested by Owner.

11.2.3. The certificates of insurance and required insurance policies shall contain provisions that thirty (30) days prior written notice by registered or certified mail shall be given Owner of any cancellation, intent not to renew, or reduction in the policies or coverages, except in the application of the aggregate limits provisions. In the event of a reduction in the aggregate limit of any policy, Contractor shall immediately take steps to have the aggregate limit reinstated to the full extent permitted under such policy.

11.2.4. All insurance coverages of the Contractor shall be primary to any insurance or self insurance program carried by the Owner applicable to this project. The acceptance by Owner of any certificate of insurance does not constitute approval or agreement by the

Owner that the insurance requirements have been satisfied or that the insurance policy shown on the certificate of insurance is in compliance with the requirements of the Contract Documents. No work shall commence at the project site unless and until the required certificates of insurance are received by the Owner

11.2.5. Contractor shall require each of its Subcontractors to procure and maintain, until the completion of the Subcontractor's work, insurance of the types and to the limits specified in Article 11, unless such insurance requirements for the Subcontractor is expressly waived in writing by the Owner. All liability insurance policies, other than professional liability, worker's compensation and employer's liability policies, obtained by Contractor to meet the requirements of the Contract Documents shall name the Santa Rosa County Board of County Commissioners as an additional insured and shall contain severability of interest provisions. The Board of County Commissioners shall also be designated as certificate holder with the address of 6495 Caroline Street, Suite M, Milton, Florida 32570. If any insurance provided pursuant to the Contract Documents expires prior to the completion of the work, renewal certificates of insurance and, if requested by Owner, certified, true copies of the renewal policies, shall be furnished by Contractor within thirty (30) days prior to the date of expiration. Upon expiration of an insurance policy term during the course of work under the contract, succeeding insurance policies shall be consecutive to the expiring policy.

11.2.6 All liability policies shall be underwritten on the "occurrence" basis, unless otherwise approved in writing by the county division of risk management. "Claims made" policies, if approved by the risk manager, and subsequent insurance certificates shall provide a "retro-date" which shall include the effective date of the contract. "Claims-made" renewals or carrier and policy replacements shall reflect the original "retro-date."

11.2.7 Should at any time the Contractor not maintain the insurance coverages required herein, the Owner may terminate the agreement or at its sole discretion shall be authorized to purchase such coverages and charge the Contractor for such coverages purchased. The Owner shall be under no obligation to purchase such insurance, nor shall it be responsible for the coverages purchased or the insurance company or companies used. The decision of the Owner to purchase such insurance coverages shall in no way be construed to be a waiver of any of its rights under the Contract Documents.

11.2.8 Contractor shall submit to Owner a copy of all accident reports arising out of any personal injuries or property damages arising or alleged to have arisen on account of any work by Contractor or Subcontractor under the Contract Documents.

11.2.9 Duty to Provide Legal Defense. The Contractor agrees to pay, to Santa Rosa County, as well as provide a legal defense for the Owner, which shall include attorneys' fees and costs, both of which will be done only if and when requested by the Owner, for all claims as described in paragraph 13.1. Such payment on the behalf of the Owner shall be in addition to any and all other legal remedies available to the Owner and shall not be considered to be the Owner's exclusive remedy.

11.3 PERFORMANCE BOND AND PAYMENT BOND

11.3.1 BONDS

11.3.1.1 Contractor shall provide performance and payment bonds, in the form prescribed in Exhibit B, in the amount of 100% of the contract amount, the costs of which to be paid by Contractor. The performance and payment bonds shall be underwritten by a

surety authorized to do business in the State of Florida and otherwise acceptable to Owner; provided; however, the surety shall be rated as "A" or better and Class XII or higher rating as to financial size category and the amount required shall not exceed 2% of the reported policy holders surplus, all as reported in the most current best key rating guide, published by A.M. Best Company, Inc. of 75 Fulton Street, New York, New York 10038.

11.3.1.2 If the surety for any bond furnished by Contractor is declared bankrupt, becomes insolvent, its right to do business is terminated in the State of Florida, or it ceases to meet the requirements imposed by the Contract Document, the Contractor shall, within five (5) calendar days thereafter, substitute another bond and surety, both of which shall be subject to the Owner's approval.

11.3.1.3 As per Florida Statutes, Section 255.05, the Contractor shall be required to execute and record the performance and payment bonds. The bonds must state the name and principal business address of both the principal and the surety and a description of the project sufficient to identify it.

ARTICLE 12: UNCOVERING AND CORRECTION OF WORK

12.1 UNCOVERING OF WORK

12.1.1 If a portion of the Work is covered contrary to the Engineer's request or to requirements specifically expressed in the Contract Documents, it must, if required in writing by the Engineer, be uncovered for the Engineer's examination and be replaced at the Contractor's expense without change in the Contract Time.

12.1.2 If a portion of the Work has been covered which the Engineer has not specifically requested to examine prior to its being covered, the Engineer may request to see such Work and it shall be uncovered by the Contractor. If such Work is in accordance with the Contract Documents, costs of uncovering and replacement shall, by appropriate Change Order, be at the Owner's expense. If such Work is not in accordance with the Contract Documents, correction shall be at the Contractor's expense unless the condition was caused by the Owner or a separate Contractor in which event the Owner shall be responsible for payment of such costs.

12.2 CORRECTION OF WORK

12.2.1 BEFORE OR AFTER SUBSTANTIAL COMPLETION

12.2.1.1 The Contractor shall promptly correct Work rejected by the Engineer or failing to conform to the requirements of the Contract Documents, whether discovered before or after Substantial Completion and whether or not fabricated, installed or completed. Costs of correcting such rejected Work, including additional testing and inspections and compensation for the Engineer's services and expenses made necessary thereby, shall be at the Contractor's expense.

12.2.2 AFTER SUBSTANTIAL COMPLETION

12.2.2.1 In addition to the Contractor's obligations under Paragraph **3.5**, if, within one year after the date of Substantial Completion of the Work or designated portion thereof or after the date for commencement of warranties established under Subparagraph **9.9.1**, or by terms of an applicable special warranty required by the Contract Documents, any of the Work is found to be not in accordance with the requirements of the Contract Documents, the Contractor shall correct it promptly after receipt of written notice from the Owner to do so unless the Owner has previously given the Contractor a written acceptance of such condition. The Owner shall give such notice promptly after discovery of the condition. During the one- year period for correction of Work, if the

Owner fails to notify the Contractor and give the Contractor an opportunity to make the correction, the Owner waives the rights to require correction by the Contractor and to make a claim for breach of warranty. If the Contractor fails to correct nonconforming Work within a reasonable time during that period after receipt of notice from the Owner or Engineer, the Owner may correct it in accordance with Paragraph 2.4.

12.2.2.2 The one-year period for correction of Work shall be extended with respect to portions of Work first performed after Substantial Completion by the period of time between Substantial Completion and the actual performance of the Work.

12.2.2.3 The one-year period for correction of Work shall not be extended by corrective Work performed by the Contractor pursuant to this Paragraph 12.2.

12.2.3 The Contractor shall remove from the site portions of the Work which are not in accordance with the requirements of the Contract Documents and are neither corrected by the Contractor nor accepted by the Owner.

12.2.4 The Contractor shall bear the cost of correcting destroyed or damaged construction, whether completed or partially completed, of the Owner or separate Contractors caused by the Contractor's correction or removal of Work which is not in accordance with the requirements of the Contract Documents.

12.2.5 Nothing contained in this Paragraph 12.2 shall be construed to establish a period of limitation with respect to other obligations which the Contractor might have under the Contract Documents. Establishment of the one-year period for correction of Work as described in Subparagraph 12.2.2 relates only to the specific obligation of the Contractor to correct the Work, and has no relationship to the time within which the obligation to comply with the Contract Documents may be sought to be enforced, nor to the time within which proceedings may be commenced to establish the Contractor's liability with respect to the Contractor's obligations other than specifically to correct the Work.

12.3 ACCEPTANCE OF NONCONFORMING WORK

12.3.1 If the Owner prefers to accept Work which is not in accordance with the requirements of the Contract Documents, the Owner may do so instead of requiring its removal and correction, in which case the Contract Sum will be reduced as appropriate and equitable. Such adjustment shall be effected whether or not final payment has been made.

ARTICLE 13: MISCELLANEOUS PROVISIONS

13.1 GOVERNING LAW

13.1.1 The Contract shall be governed by the law of the place where the Project is located.

13.2 SUCCESSORS AND ASSIGNS

13.2.1 The Owner and Contractor respectively bind themselves, their partners, successors, assigns and legal representatives to the other party hereto and to partners, successors, assigns and legal representatives of such other party in respect to covenants, agreements and obligations contained in the Contract Documents. Except as provided in Subparagraph 13.2.2, neither party to the Contract shall assign the Contract as a whole without written consent of the other. If either party attempts to make such an assignment without such consent, that party shall nevertheless remain legally responsible for all obligations under the Contract.

13.2.2 The Owner may, without consent of the Contractor, assign the Contract to an institutional lender providing construction financing for the Project. In such event, the

lender shall assume the Owner's rights and obligations under the Contract Documents. The Contractor shall execute all consents reasonably required to facilitate such assignment.

13.3 WRITTEN NOTICE

13.3.1 Written notice shall be deemed to have been duly served if delivered in person to the individual or a member of the firm or entity or to an officer of the corporation for which it was intended, or if delivered at or sent by registered or certified mail to the last business address known to the party giving notice.

13.4 RIGHTS AND REMEDIES

13.4.1 Duties and obligations imposed by the Contract Documents and rights and remedies available thereunder shall be in addition to and not a limitation of duties, obligations, rights and remedies otherwise imposed or available by law.

13.4.2 No action or failure to act by the Owner, Engineer or Contractor shall constitute a waiver of a right or duty afforded them under the Contract, nor shall such action or failure to act constitute approval of or acquiescence in a breach thereunder, except as may be specifically agreed in writing.

13.5 TESTS AND INSPECTIONS

13.5.1 Tests, inspections and approvals of portions of the Work required by the Contract Documents or by laws, ordinances, rules, regulations or orders of public authorities having jurisdiction shall be made at an appropriate time. Unless otherwise provided, the Contractor shall make arrangements for such tests, inspections and approvals with an independent testing laboratory or entity acceptable to the Owner, or with the appropriate public authority, and shall bear all related costs of tests, inspections and approvals. The Contractor shall give the Engineer timely notice of when and where tests and inspections are to be made so that the Engineer may be present for such procedures. The Owner shall bear costs of tests, inspections or approvals which do not become requirements until after bids are received or negotiations concluded.

13.5.2 If the Engineer, Owner or public authorities having jurisdiction determine that portions of the Work require additional testing, inspection or approval not included under Subparagraph **13.5.1**, the Engineer will, upon written authorization from the Owner, instruct the Contractor to make arrangements for such additional testing, inspection or approval by an entity acceptable to the Owner, and the Contractor shall give timely notice to the Engineer of when and where tests and inspections are to be made so that the Engineer may be present for such procedures. Such costs, except as provided in Subparagraph **13.5.3**, shall be at the Owner's expense.

13.5.3 If such procedures for testing, inspection or approval under Subparagraphs **13.5.1** and **13.5.2** reveal failure of the portions of the Work to comply with requirements established by the Contract Documents, all costs made necessary by such failure including those of repeated procedures and compensation for the Engineer's services and expenses shall be at the Contractor's expense.

13.5.4 Required certificates of testing, inspection or approval shall, unless otherwise required by the Contract Documents, be secured by the Contractor and promptly delivered to the Engineer.

13.5.5 If the Engineer is to observe tests, inspections or approvals required by the Contract Documents, the Engineer will do so promptly and, where practicable, at the normal place of testing.

13.5.6 Tests or inspections conducted pursuant to the Contract Documents shall be made promptly to avoid unreasonable delay in the Work.

13.6 INTEREST

13.6.1 Payments due and unpaid under the Contract Documents shall bear interest from the date payment is due at such rate as the parties may agree upon in writing or, in the absence thereof, at the legal rate prevailing from time to time at the place where the Project is located.

13.7 COMMENCEMENT OF STATUTORY LIMITATION PERIOD

13.7.1 As between the Owner and Contractor:

- 1** Before Substantial Completion. As to acts or failures to act occurring prior to the relevant date of Substantial Completion, any applicable statute of limitations shall commence to run and any alleged cause of action shall be deemed to have accrued in any and all events not later than such date of Substantial Completion;
- 2** Between Substantial Completion and Final Certificate for Payment. As to acts or failures to act occurring subsequent to the relevant date of Substantial Completion and prior to issuance of the final Certificate for Payment, any applicable statute of limitations shall commence to run and any alleged cause of action shall be deemed to have accrued in any and all events not later than the date of issuance of the final Certificate for Payment; and
- 3** After Final Certificate for Payment. As to acts or failures to act occurring after the relevant date of issuance of the final Certificate for Payment, any applicable statute of limitations shall commence to run and any alleged cause of action shall be deemed to have accrued in any and all events not later than the date of any act or failure to act by the Contractor pursuant to any Warranty provided under Paragraph **3.5**, the date of any correction of the Work or failure to correct the Work by the Contractor under Paragraph **12.2**, or the date of actual commission of any other act or failure to perform any duty or obligation by the Contractor or Owner, whichever occurs last.

ARTICLE 14: TERMINATION OR SUSPENSION OF THE CONTRACT

14.1 TERMINATION BY THE CONTRACTOR

14.1.1 The Contractor may terminate the Contract if the Work is stopped for a period of **30** consecutive days through no act or fault of the Contractor or a Subcontractor, Sub-Subcontractor or their agents or employees or any other persons or entities performing portions of the Work under direct or indirect contract with the Contractor, for any of the following reasons.

- 1** issuance of an order of a court or other public authority having jurisdiction which requires all Work to be stopped;
- 2** an act of government, such as a declaration of national emergency which requires all Work to be stopped;
- 3** because the Engineer has not issued a Certificate for Payment and has not notified the Contractor of the reason for withholding certification as provided in Subparagraph **9.4.1**, or because the Owner has not made payment on a Certificate for Payment within the time stated in the Contract Documents; or
- 4** the Owner has failed to furnish to the Contractor promptly, upon the Contractor's request, reasonable evidence as required by Subparagraph **2.2.1**.

14.1.2 The Contractor may terminate the Contract if, through no act or fault of the Contractor or a Subcontractor, Sub- Subcontractor or their agents or employees or any other persons or entities performing portions of the Work under direct or indirect contract with the Contractor, repeated suspensions, delays or interruptions of the entire Work by the Owner as described in Paragraph **14.3** constitute in the aggregate more than 100 percent of the total number of days scheduled for completion, or **120** days in any 365-day period, whichever is less.

14.1.3 If one of the reasons described in Subparagraph **14.1.1** or **14.1.2** exists, the Contractor may, upon seven days' written notice to the Owner and Engineer, terminate the Contract and recover from the Owner only as provided in Subparagraph **14.3.1**.

14.1.4 *If the Work is stopped for a period of 60 consecutive days through no act or fault of the Contractor or a Subcontractor or their agents or employees or any other persons performing portions of the Work under contract with the Contractor because the Owner has persistently failed to fulfill the Owner's obligations under the Contract Documents with respect to matters important to the progress of the Work, the Contractor may, upon seven additional days' written notice to the Owner and the Engineer, terminate the Contract and recover from the Owner only as provided in Subparagraph **14.3.1**.*

14.2 **TERMINATION FOR DEFAULT**

14.2.1 Contractor shall be considered in material default of the agreement and such default shall be considered cause for Owner to terminate the agreement, in whole or in part, as further set forth in this section, if Contractor: (1) fails to begin the work under the Contract Documents within the time specified herein; or (2) fails to properly and timely perform the work as directed by the Owner or as provided for in the approved progress schedule; or (3) performs the work unsuitably or neglects or refuses to remove materials or to correct or replace such work as may be rejected as unacceptable or unsuitable; or (4) discontinues the prosecution of the work; or (5) fails to resume work which has been suspended within a reasonable time after being notified to do so; or (6) becomes insolvent or is declared bankrupt, or commits any act of bankruptcy; or (7) allows any final judgment to stand against it unsatisfied for more than ten (10) days; or (8) makes an assignment for the benefit of creditors; or (9) fails to obey any applicable codes, laws, ordinances, rules or regulations with respect to the work; or (10) materially breaches any other provision of the Contract Documents.

14.2.2 Owner shall notify Contractor in writing of Contractor's default(s). If Owner determines that Contractor has not remedied and cured the default(s) within seven (7) calendar days following receipt by Contractor of said written notice, then Owner, at its option, without releasing or waiving its rights and remedies against the Contractor's sureties and without prejudice to any other right or remedy it may be entitled to hereunder or by law, may terminate Contractor's right to proceed under the agreement, in whole or in part, and take possession of all or any portion of the work and any materials, tools, equipment, and appliances of Contractor, take assignments of any of Contractor's subcontracts and purchase orders, and complete all or any portion of Contractor's work by whatever means, method or agency which Owner, in its sole discretion, may choose.

14.2.3 If Owner deems any of the foregoing remedies necessary, Contractor agrees that is shall not be entitled to receive any further payments hereunder until after the project is completed. All monies expended and all of the costs, losses, damages and extra expenses, including all management, administrative and other overhead and other direct and indirect

expenses (including attorneys' fees) or damages incurred by Owner incident to such completion, shall be deducted from the contract amount, and if such expenditures exceed the unpaid balance of the contract amount, Contractor agrees to pay promptly to Owner on demand the full amount of such excess, including costs of collection, attorney's fees (including appeals) and interest thereon at the maximum legal rate of interest until paid. If the unpaid balance of the contract amount exceeds all such costs, expenditures and damages incurred by the Owner to complete the work, such excess shall be paid to the Contractor. The amount to be paid to the Contractor or Owner, as the case may be, and this obligation for payment shall survive termination of the agreement.

14.2.4. The liability of Contractor hereunder shall extend to and include the full amount of any and all sums paid, expenses and losses incurred, damages sustained, and obligations assumed by Owner in good faith under the belief that such payments or assumptions were necessary or required, in completing the work and providing labor, materials, equipment, supplies, and other items therefor or re-letting the work, in settlement, discharge or compromise of any claims, demands, suits, and judgments pertaining to or arising out of the work hereunder.

14.2.5 If, after notice of termination of Contractor's right to proceed pursuant to this section, it is determined for any reason that Contractor was not in default, or that its default was excusable, or that Owner is not entitled to the remedies against Contractor provided herein, then Contractor's remedies against Owner shall be the same as and limited to those afforded Contractor below under subsection **14.3.1**, termination for convenience.

14.3 TERMINATION FOR CONVENIENCE AND RIGHT OF SUSPENSION

14.3.1. Owner shall have the right to terminate this agreement without cause upon seven (7) calendar days written notice to Contractor. In the event of such termination for convenience, Contractor's recovery against Owner shall be limited to that portion of the contract amount earned through the date of termination, together with any retainage withheld and reasonable termination expenses incurred, but Contractor shall not be entitled to any other or further recovery against Owner, including, but not limited to, damages or any anticipated profit on portions of the work not performed.

14.3.2. Owner shall have the right to suspend all or any portions of the work upon giving Contractor two (2) calendar days' prior written notice of such suspension. If all or any portion of the work is so suspended, Contractor's sole and exclusive remedy shall be to seek an extension of time to its schedule in accordance with the procedures set forth in the Contract Documents. In no event shall the Contractor be entitled to any additional compensation or damages. Provided, however, if the ordered suspension exceeds three (3) months, the Contractor shall have the right to terminate the agreement with respect to that portion of the work which is subject to the ordered suspension.

ARTICLE 1: SUPPLEMENTAL PROVISIONS

GENERAL CONDITIONS:

The following conditions supplement, modify, change, delete from or add to the General Provisions of the Contract, Articles 1 through 14. Where an Article of the General Provisions is modified or a Paragraph, Subparagraph, or Clause thereof is modified or deleted by these supplements, the unaltered provisions of that Article, Paragraph, Subparagraph, or Clause shall remain in effect.

2.0 FORM OF CONTRACT AND BONDS:

The contract form as furnished by Santa Rosa County shall be utilized. Performance and Payment Bond forms as approved by Santa Rosa County shall be utilized.

3.0 MATERIALS:

Whenever "or approved equal" is indicated, items proposed for use shall be submitted for Engineer's approval. Wherever an item or class of material is specified exclusively by trade name or by name of the maker or by catalog reference, only such items shall be used unless previously approved through addenda by the Engineer. Should the Contractor desire to substitute another material for one or more specified by name they shall state the credit or extra involved by the use of such material, in their bid. No such materials shall be used unless approved in writing by the Engineer.

4.0 PROGRESS CHART:

Within ten (10) days after receipt of signed Contract the Contractor shall file with the Engineer a progress chart showing the order in which the Contractor proposes to accomplish the work, the dates on which he proposes to begin the various parts of the work and the dates he contemplates completing them.

5.0 TIME FOR COMPLETION:

Time for completion of all work included in this contract shall not exceed **90 days** from date of written Notice to proceed. The number of days allowed does not include an allowance for calendar days missed due to weather. Extension of time will be allowed for delays due to weather if properly documented and reported to the Engineer.

6.0 PRECONSTRUCTION CONFERENCE:

Within ten (10) days after the effective date of the agreement, but before Contractor starts the work at the Project site, a conference will be held for review and acceptance of the schedules referred to in paragraph 4.0, to establish procedures for processing applications for payment, and to establish a working understanding among the parties as to the work.

7.0 RECORD KEEPING

The Contractor shall maintain all relevant project records for three years after the Owner has made final payment to the Contractor.

SECTION IV.
PROJECT MANUAL, SPECIFICATIONS, PLANS AND
SUPPORTING DOCUMENTATION

This Page Intentionally Left Blank

Project Summary

Navarre Beach Boat Ramp Private Aids to Navigation RFP

Project Scope of Work

The site is located in Santa Rosa Sound adjacent to the west side of the Navarre Beach Causeway, from the intercoastal waterway navigation channel to the Navarre Beach boat ramp. This project includes the installation of 13 wood-pile channel markers/beacons, of which nine have lanterns, as-built survey, testing/monitoring, turbidity curtains, and permitting.

CONSTRUCTION PLANS FOR NAVARRE BEACH BOAT RAMP PRIVATE AIDS TO NAVIGATION

**PREPARED FOR:
SANTA ROSA COUNTY**

INDEX

<u>SHEET</u>	<u>CONTENT</u>
G-000	COVER
G-001	GENERAL NOTES AND DETAILS
C-100	PLAN

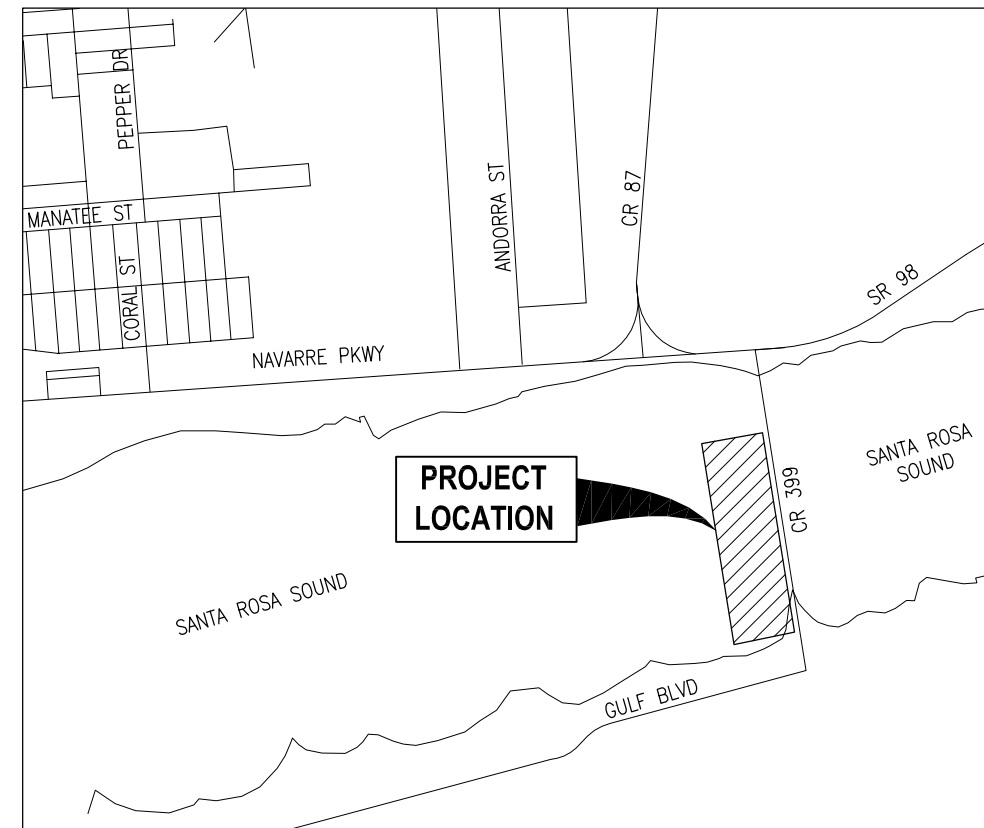

VICINITY MAP
NOT TO SCALE



ENGINEERING DEPARTMENT
6051 OLD BAGDAD HIGHWAY, SUITE 300
MILTON, FLORIDA 32583

JANUARY 2022

PROJECT NO. 14315.03

PREPARED BY

BASKERVILLE-DONOVAN, INC.
Innovative Infrastructure Solutions

449 W. MAIN ST., PENSACOLA, FL 32502 (850)438-9661
ENGINEERING BUSINESS: EB-0000340

Pensacola - Panama City Beach - Tallahassee - Mobile

THIS DOCUMENT HAS BEEN DIGITALLY
SIGNED AND SEALED BY WILLIAM J.
HUGGINS ON THE DATE ADJACENT TO THE
SEAL. PRINTED COPIES OF THIS
DOCUMENT ARE NOT CONSIDERED
SIGNED AND SEALED AND THE
SIGNATURE MUST BE VERIFIED ON ANY
ELECTRONIC COPIES.

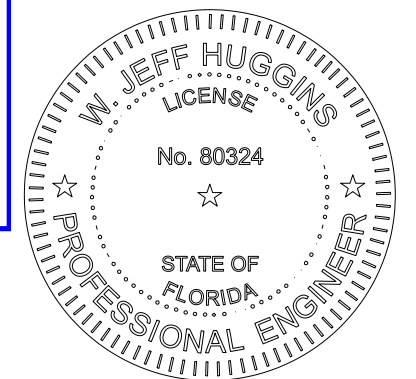

RELEASED FOR BID PLAN SET

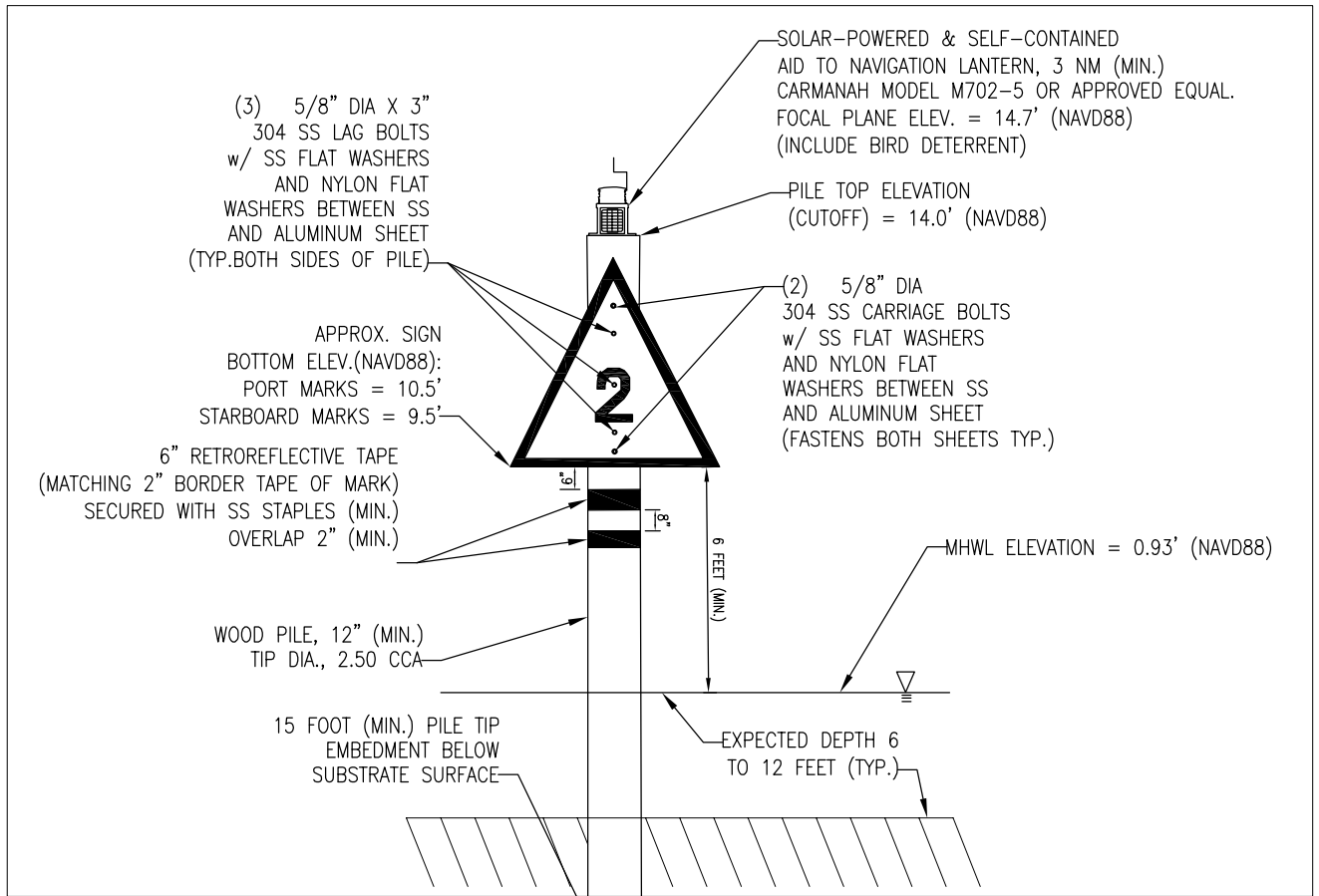

PRIVATE AID TO NAVIGATION INSTALLATION DETAIL
(NTS)

PILING NOTES:

- MARKS WITHOUT LIGHTS SHALL HAVE PILE CAPS EQUAL TO THE TOP DIAMETER WITHOUT MODIFICATION. TOP OF PILE CAPS SHALL EQUAL THE SAME ELEVATION AS THE PROPOSED FOCAL PLANE OF LIGHTS.
- DAYBOARD FASTENERS SHALL NOT EXTEND 1" BEYOND THE NUT AND WASHER
- CONTRACTOR SHALL CONFIRM DEPTH AT PROPOSED PILE LOCATION PRIOR TO ORDERING PILINGS.
- PILINGS SHALL BE SOUTHERN PINE TIMBER PILINGS, 2.50 CCA. NO SPLICED PILINGS WILL BE PERMITTED.
- CONTRACTOR SHALL PROTECT PILING DURING DRIVING OPERATIONS TO PREVENT SPLITTING OR DAMAGE TO THE PILING.
- USE ACTUAL LIGHT OR PILING CAP DIMENSIONS TO DETERMINE FINAL PILE TOP (CUTOFF) ELEVATION.
- PILINGS DAMAGED OR NOT DRIVEN PLUM, SHALL BE REMOVED AND REPLACED.
- LIGHTS SHALL BE FASTENED AS SPECIFIED BY THE MANUFACTURER.
- LIGHTS SHALL COMPLY WITH FEDERAL REGISTER TITLE 33, CFR, CHAPTER 1, SUBCHAPTER C, PART 66.
- PILINGS SHALL BE EMBEDDED 15' (MIN.). THE CONTRACTOR SHALL NOTIFY THE ENGINEER IF ANTICIPATED SUBMERGED LANDS ELEVATIONS DIFFER FROM THOSE SHOWN.

GENERAL PRIVATE AID TO NAVIGATION NOTES:

- MARKS WITHOUT LIGHTS SHALL HAVE PILE CAPS EQUAL TO THE TOP DIAMETER WITHOUT MODIFICATION.
- FASTENERS SHALL NOT EXTEND BEYOND 1" BEYOND THE NUT AND WASHER.
- DAYBOARDS SHALL BE MOUNTED ON BOTH SIDE OF THE PILE, PERPENDICULAR TO, OR AS BEST VISIBLE TO, THE CENTERLINE OF THE CHANNEL.
- PERMIT NUMBERS AND THE OWNER'S NAME AND CONTACT INFORMATION SHALL BE PLACED ON THE BACK OF EACH MARK.
- BIRD DETERRENTS SHALL BE INCLUDED WITH LIGHT AND INSTALLED IN ACCORDANCE WITH MANUFACTURE'S RECOMMENDATIONS.
- PRIVATE AIDS TO NAVIGATION SHALL BE INSTALLED IN ACCORDANCE WITH ALL APPLICABLE LOCAL, STATE AND FEDERAL REGULATIONS.
- PRIOR TO COMMENCEMENT, CONTRACTOR SHALL NOTIFY ALL AUTHORITIES HAVING JURISDICTION IN ACCORDANCE WITH APPLICABLE REGULATIONS.
- THE CONTRACTOR SHALL COMPLY WITH THE GENERAL AND SPECIFIC CONDITIONS PROVIDED IN APPLICABLE PERMIT DOCUMENTS.

Table 2 - Lantern Specifications		
	Port Side	Starboard Side
LED Color	Green	Red
Light Output	22 Candela	16 Candela
Nominal Range	3 NM	
Vertical Divergence	7°	
Horizontal Output	360°	
Power	Solar Powered	
Lantern	Marine Grade Aluminum	
Waterproof	IP67 (NEMA 6)	
CE Approval	EN 60945; 1997	
Flash Rhythm	FL2.5s	
Period	2.5 Sec.	
Flash Length	0.3 Sec.	

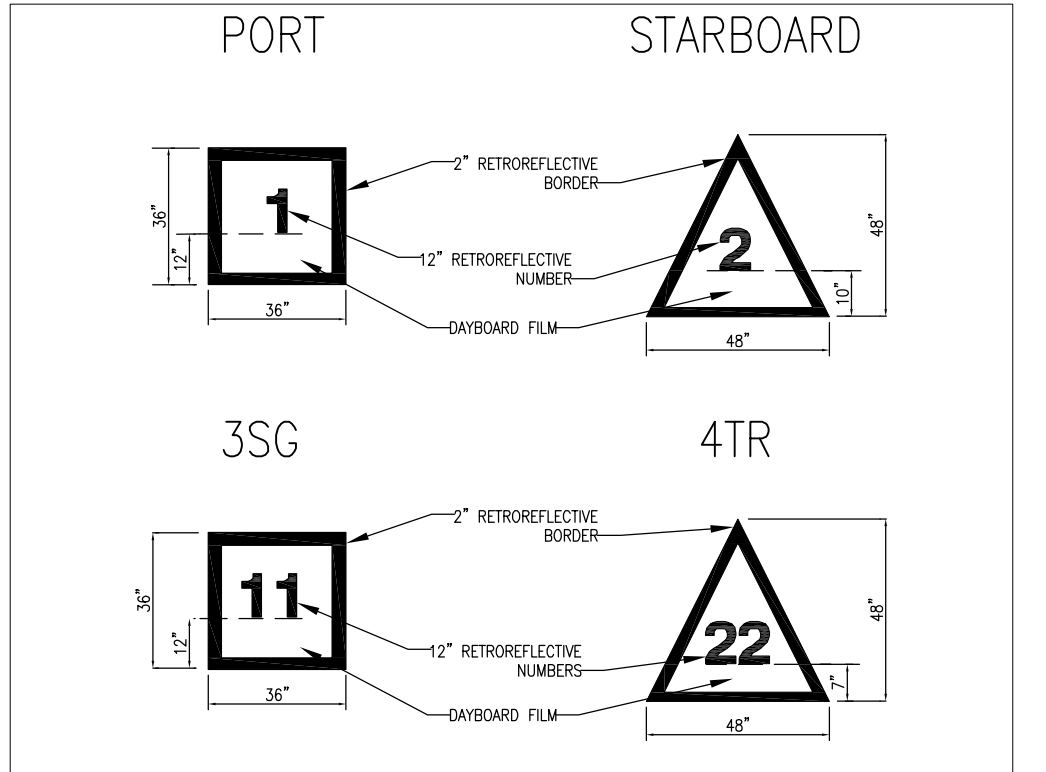

GENERAL USE PORT AND STARBOARD MARKS DETAIL (1NM)
(NTS)

DAYBOARD NOTES:

- DAYBOARDS SHALL BE CONSTRUCTED OF 1/8" COMMERCIAL GRADE ALUMINUM SHEET. COLORS, FILMS AND CHARACTERS SHALL MEET STANDARDS PROVIDED IN THE USCG AIDS TO NAVIGATION MANUAL, TECHNICAL COMDTINST M16500.3A.
- NUMBER DAYBOARDS AS SHOWN ON SHEET C-100.
- LATERAL MARKS SHALL BE PILE SUPPORTED (SEE PILING NOTES, THIS SHEET).

GENERAL NOTES:

- THE CONTRACTOR SHALL VISIT THE SITE AND BECOME FAMILIAR WITH THE PROJECT PRIOR TO BIDDING.
- B.M. DATUM IS NATIONAL GEODETIC VERTICAL DATUM OF 1988 (NGVD88)
- ANY MONUMENT AND/OR ANY PUBLIC LAND CORNER WITHIN THE LIMITS OF CONSTRUCTION SHOWN, ARE TO BE PROTECTED. IF THESE ARE IN DANGER OF BEING DAMAGED, THE CONTRACTOR SHOULD NOTIFY THE ENGINEER IMMEDIATELY, WHO WILL CONTACT THE PROPER AUTHORITIES.
- UTILITY RELOCATIONS WILL BE BY OTHERS. EXISTING UNDERGROUND UTILITY LOCATIONS SHOWN WERE PROVIDED BY UTILITY COMPANIES AND HAVE NOT BEEN VERIFIED BY THE ENGINEER. THE CONTRACTOR IS RESPONSIBLE TO DETERMINE THE EXACT LOCATIONS AND DEPTHS OF ALL UTILITIES INCLUDING, BUT NOT LIMITED TO, WATER LINES AND SANITARY SEWER LINES BURIED TELEPHONE LINES, BURIED ELECTRICAL LINES AND GAS MAINS PRIOR TO COMMENCEMENT OF CONSTRUCTION. CONTRACTOR IS TO COORDINATE WITH UTILITY COMPANIES FOR REMOVAL AND/OR RELOCATION OF EXISTING UTILITY POLES, AERIAL LINES, BURIED CABLE AND OTHER UTILITIES.
- THE CONTRACTOR SHALL NOTIFY THE ENGINEER IMMEDIATELY OF ANY CONFLICTS BETWEEN CONTRACT DOCUMENTS AND EXISTING CONDITIONS. THESE DRAWINGS REPRESENT KNOWN STRUCTURES AND UTILITIES LOCATED IN THE PROJECT AREA. THE CONTRACTOR IS CAUTIONED THAT OTHER STRUCTURES AND UTILITIES, ABOVE OR BELOW GROUND, MAY BE ENCOUNTERED DURING THE COURSE OF THE PROJECT. THE CONTRACTOR SHOULD NOTIFY THE UTILITY, THEN THE ENGINEER, IMMEDIATELY UPON ENCOUNTERING ANY UNEXPECTED STRUCTURE, UTILITY LINE, OR OTHER UNUSUAL CONDITION. EXISTING CONDITIONS ARE BASED ON SURVEYS BY BASKERVILLE-DONOVAN, INC. PERFORMED IN 2016.
- RIGHT-OF-WAY LINE LOCATIONS AS SHOWN IN THE PLANS ARE APPROXIMATE; RIGHT-OF-WAY LINES SHOWN ARE PER SANTA ROSA COUNTY RECORDS AND BDI SURVEY WORK. THE CONTRACTOR IS TO ENSURE THAT THE CONSTRUCTION REMAINS WITHIN COUNTY RIGHT-OF-WAY OR EASEMENT AS DEPICTED IN THE PLANS. CONTRACTOR SHALL CONFINE ALL ACTIVITIES WITHIN DESIGNATED CONSTRUCTION LIMITS (RIGHT-OF-WAY OR EASEMENT). DO NOT ENTER PRIVATE PROPERTY WITHOUT PRIOR APPROVAL FROM ENGINEER.
- CONTRACTOR SHALL MARK ANY INSTALLED IMPROVEMENTS PRIOR TO LEAVING THE SITE DAILY TO ENSURE PILES ARE VISIBLE TO VESSELS.
- THE CONTRACTOR IS RESPONSIBLE FOR COORDINATING ANY NECESSARY UTILITY ADJUSTMENTS/RELOCATION. CONTRACTOR SHALL CONTACT SUNSHINE UTILITIES (1-800-432-4770) PRIOR TO COMMENCEMENT.
- UPON COMPLETION OF CONSTRUCTION THE CONTRACTOR SHALL SUBMIT "AS BUILT" DRAWINGS PRIOR TO REQUEST FOR FINAL PAYMENT.
- MARKS SHALL BE OPERATED AND MAINTAINED IN ACCORDANCE WITH FEDERAL, STATE AND LOCAL LAWS AND REGULATIONS REGARDING PRIVATE AIDS TO NAVIGATION
- NOAA CHART 11385 USED AS REFERENCE IN DESIGN.

K:\143 Santa Rosa\14315.00\14315.03 - Navarre Navigation\DWG\WJH Details.dwg, Jan 26, 2022 - 3:04:00PM, jhuggins

W. JEFF HUGGINS, P.E.
FL. Reg. Engineer #90324

NAVARRE BEACH BOAT
RAMP PRIVATE AIDS TO
NAVIGATION

NO.	DATE	APPR.	REVISION/ACTION TAKEN

PROJECT NO: 14315.03
DESIGNED BY: WJH
DRAWN BY: RCG
CHK'D BY: HFB
PROJ. MGR: WJH
DATE: MAY 2021

GENERAL NOTES
AND DETAILS

SURVEYOR'S NOTES:

1. NORTH AND THE SURVEY DATUM SHOWN HEREON IS BASED ON THE FLORIDA STATE PLANE COORDINATE SYSTEM, NORTH ZONE, NORTH AMERICAN DATUM OF 1983 (NAD83), AND EXISTING FIELD MONUMENTATION.
2. THE VERTICAL DATUM SHOWN HEREON IS BASED ON THE NORTH AMERICAN VERTICAL DATUM OF 1988 (NAVD88), AND EXISTING FIELD MONUMENTATION.
3. NO TITLE SEARCH, TITLE OPINION, OR ABSTRACT WAS PERFORMED BY NOR PROVIDED TO THIS FIRM FOR THE SUBJECT PROPERTY. THERE MAY BE DEEDS OF RECORD, UNRECORDED DEEDS, EASEMENTS, RIGHTS-OF-WAY, BUILDING SETBACKS, RESTRICTIVE COVENANTS OR OTHER INSTRUMENTS WHICH COULD AFFECT THE BOUNDARIES OR USE OF THE SUBJECT PROPERTY.
4. THE FIELD SURVEY SHOWN HEREON, PREFORMED BY BASKERVILLE-DONOVAN, INC. ON AUGUST 2020 AND RECORDED IN FIELD BOOK 20-03, PAGES 58-60.
5. THE MHWL SHOWN HEREON IS BASED ON THE PUBLISHED ELEVATION OF 0.93 FEET (NAVD88) AND FIELD LOCATED ON 08/26/2020.

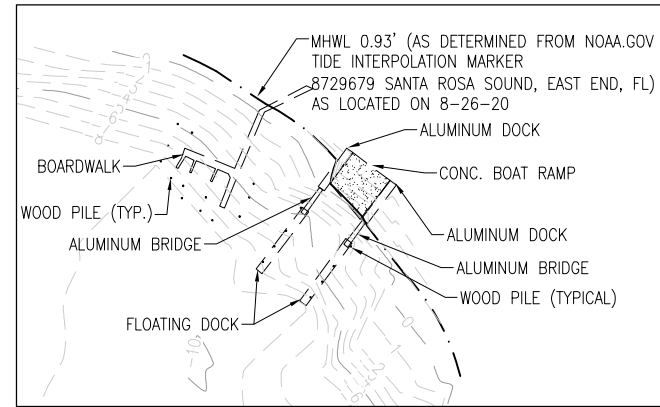

ENLARGEMENT

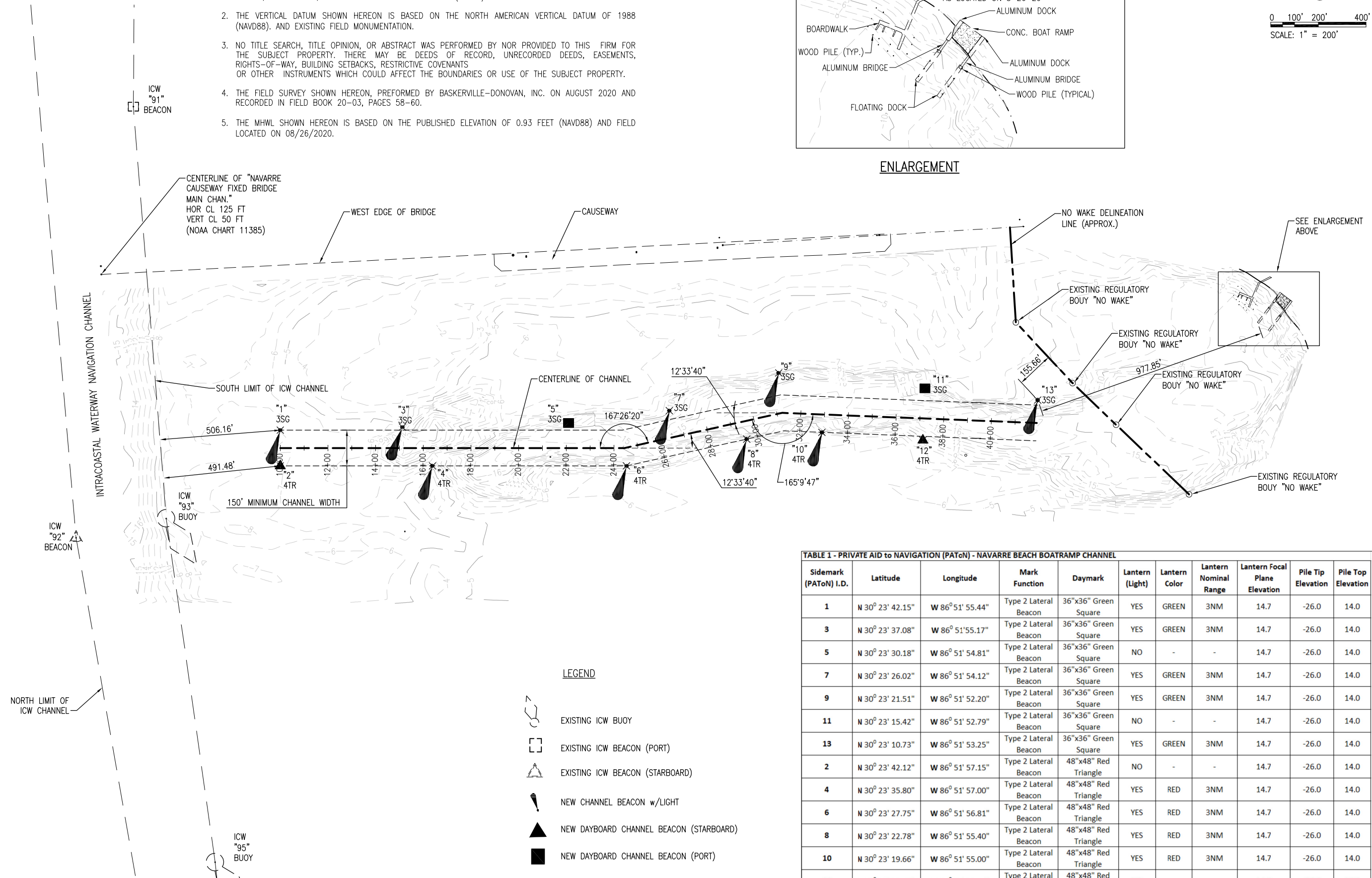
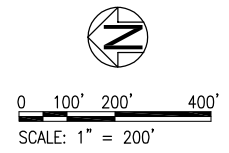

LEGEND

- EXISTING ICW BUOY
- EXISTING ICW BEACON (PORT)
- EXISTING ICW BEACON (STARBOARD)
- NEW CHANNEL BEACON w/LIGHT
- NEW DAYBOARD CHANNEL BEACON (STARBOARD)
- NEW DAYBOARD CHANNEL BEACON (PORT)

TABLE 1 - PRIVATE AID TO NAVIGATION (PAToN) - NAVARRE BEACH BOATRAMP CHANNEL

Sidemark (PAToN) I.D.	Latitude	Longitude	Mark Function	Daymark	Lantern (Light)	Lantern Color	Lantern Nominal Range	Lantern Focal Plane Elevation	Pile Tip Elevation	Pile Top Elevation
1	N 30° 23' 42.15"	W 86° 51' 55.44"	Type 2 Lateral Beacon	36"x36" Green Square	YES	GREEN	3NM	14.7	-26.0	14.0
3	N 30° 23' 37.08"	W 86° 51' 55.17"	Type 2 Lateral Beacon	36"x36" Green Square	YES	GREEN	3NM	14.7	-26.0	14.0
5	N 30° 23' 30.18"	W 86° 51' 54.81"	Type 2 Lateral Beacon	36"x36" Green Square	NO	-	-	14.7	-26.0	14.0
7	N 30° 23' 26.02"	W 86° 51' 54.12"	Type 2 Lateral Beacon	36"x36" Green Square	YES	GREEN	3NM	14.7	-26.0	14.0
9	N 30° 23' 21.51"	W 86° 51' 52.20"	Type 2 Lateral Beacon	36"x36" Green Square	YES	GREEN	3NM	14.7	-26.0	14.0
11	N 30° 23' 15.42"	W 86° 51' 52.79"	Type 2 Lateral Beacon	36"x36" Green Square	NO	-	-	14.7	-26.0	14.0
13	N 30° 23' 10.73"	W 86° 51' 53.25"	Type 2 Lateral Beacon	36"x36" Green Square	YES	GREEN	3NM	14.7	-26.0	14.0
2	N 30° 23' 42.12"	W 86° 51' 57.15"	Type 2 Lateral Beacon	48"x48" Red Triangle	NO	-	-	14.7	-26.0	14.0
4	N 30° 23' 35.80"	W 86° 51' 57.00"	Type 2 Lateral Beacon	48"x48" Red Triangle	YES	RED	3NM	14.7	-26.0	14.0
6	N 30° 23' 27.75"	W 86° 51' 56.81"	Type 2 Lateral Beacon	48"x48" Red Triangle	YES	RED	3NM	14.7	-26.0	14.0
8	N 30° 23' 22.78"	W 86° 51' 55.40"	Type 2 Lateral Beacon	48"x48" Red Triangle	YES	RED	3NM	14.7	-26.0	14.0
10	N 30° 23' 19.66"	W 86° 51' 55.00"	Type 2 Lateral Beacon	48"x48" Red Triangle	YES	RED	3NM	14.7	-26.0	14.0
12	N 30° 23' 15.47"	W 86° 51' 55.28"	Type 2 Lateral Beacon	48"x48" Red Triangle	NO	-	-	14.7	-26.0	14.0

K:\143 Santa Rosa\14315.00\14315.03 - Navarre Navigation\DWG\WJH_C-100 Overall.dwg, Jan 26, 2022 - 3:03:12PM, jhuggins

W. JEFF HUGGINS, P.E.
 FL. Reg. Engineer #90324

NAVARRE BEACH BOAT RAMP PRIVATE AIDS TO NAVIGATION

PROJECT NO.	DESIGNED BY	DRAWN BY	CHK'D BY	PROJ. MGR.	DATE
14315.03	RG	WJH	WJH	WJH	MAY 2021

PLAN

BID SUBMISSION CHECKLIST

Project Name: **Navarre Beach Boat Ramp Private Aids To Navigation** Solicitation# **22-017**

Date of Bid Opening March 3, 2022 Time: 1-:15 A.M.

- Sealed Bid Package with Bid Name and Number, Firm name and Address with Contact information clearly marked on the outside of envelope/box.
- 1 Original Bid Package with 1 Electronic Copy in .pdf on a CD or USB Drive
- Bid Submittal Checklist attached to top of Original Bid Package
- Bid Form
- Schedule of Values, Unit Pricing
- Cone of Silence
- Sworn Statement Public Entity Crimes (016)
- Debarment Form (022)
- References Form (024)
- Copy of current Required Insurance declaration page with Santa Rosa County named interest, or, Letter of Insurability from Carrier stating that the levels of coverage will be obtained.
- Addendum (s) if any
- Proof of Registration with State of Florida Division of Corporations (Sunbiz.org)

All required documentation submitted must be updated with most current and complete information from date of bid opening) including notarizations where required. Failure to submit all required forms may result in your submittal being deemed non-responsive. **ATTACH THIS PAGE TO THE TOP OF YOUR BID SUBMISSION**

Firm: Complete Site Source

By: Josh Livingston

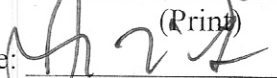
Signature: 
(Print)

Title: General Contractor

Date: 3-2-22

BID FORM

(May be copied by the Bidder on his own letterhead)

TO: Santa Rosa County Procurement Department
Attention Procurement Officer
6495 Caroline Street, Suite L
Milton, Florida 32570

REFERENCE: **ITB 22-017 Navarre Beach Boat Ramp Private Aids To Navigation**

BASE BID PRICE: \$ 98,950.⁰⁰

To whom it may concern,

I, Josh Livingston have received and reviewed the Bidding Documents consisting of Drawings and Specifications (Project Manual) entitled ITB 22-017 NAVARRE BEACH BOAT RAMP PRIVATE AIDS TO NAVIGATION, prepared by Santa Rosa County Engineering, 6051 Old Bagdad Highway, Suite 300, Milton, Florida 32570, and Baskerville-Donovan, Inc., 449 W. Main Street, Pensacola, FL 32502

I have also received Addenda Numbers _____ and have included their provisions in my Bid.

In submitting the Bid, I agree:

1. To hold my bid in full force and effect for a period of sixty (60) calendar days after the time of the opening of this Bid.
2. To accept the provisions of the Instructions to Bidders regarding disposition of Bid Guarantee.
3. To enter into and execute a Contract within 10 (ten) calendar days after said Contract is delivered to me, if awarded on the basis of this Bid.
4. To accomplish the work in accordance with the Contract Documents.
5. To commence work under this Contract on or before a date to be specified in written "Notice of Proceed" by the Procurement Department and to complete project within Ninety (90) calendar days thereafter.
6. To pay as liquidated damages, the sum of \$882.00 for each consecutive calendar day after completion date, as called for in the Contract Agreement as modified.
7. Provide Santa Rosa County with performance Bonds and adhere to Supplementary Conditions.

**SWORN STATEMENT UNDER SETION 287.133 (3) (A)
FLORIDA STATUTE ON PUBLIC ENTITY CRIMES**

*THIS FORM MUST BE SIGNED IN THE PRESENCE OF A NOTARY PUBLIC OR OTHER OFFICER
AUTHORIZED TO ADMINISTER OATHS.*

1. This sworn statement is submitted with Bid, Proposal or Contract for: Navarre Beach
Boat Ramp Private Aids to Navigation # 22-017
2. This sworn statement is submitted by, Complete Site Source, whose business address is, 212 Lakeside Ln. Mary Esther, FL 32569, and (if applicable) Federal Employer Identification Number (FEIN) is _____ (if the entity has no FEIN, include the Social Security Number of the individual signing this sworn statement).
3. My name is Josh Livingston and my relationship to the entity named above is General Contractor (title).
4. I understand that a "public entity crime" as defined in paragraph 287.133 (1) (g) Florida Statute, means a violation of any state or federal law by a person with respect to and directly related to the transaction of business with any public entity or with an agency or political subdivision of any other state or with the United States including, but not limited to, any bid or contract for goods or services to be provided to any public entity or any agency or public subdivision of any other state or of the United States and involved antitrust, fraud, theft, bribery, collusion, racketeering, conspiracy or material misrepresentation.
5. I understand that "convicted" or "convicted" as defined in paragraph 287.133 (1) (b), Florida Statutes, means a finding of guilt or a conviction of a public entity crime with or without an adjudication of guilt, in any federal or state trial court of records relating to charges brought by indictment or information after July 1, 1989, as a result of a jury verdict, non-jury trial, or entry of a plea of guilty or nolo contendere.
6. I understand that an "affiliate" as defined in Paragraph 287 .133 (1) (a), Florida Statutes, means:
 - a. A predecessor or successor of a person convicted of a public entity crime; or
 - b. An entity under the control of any natural person who is active in the management of the entity and who has been convicted of a public entity crime. The term "affiliate" includes those officers, directors, executives, partners, shareholders, employees, members, and agents who are active in the management of an affiliate. The ownership by one of shares constituting a controlling income among persons when not for fair interest in another person, or a pooling of equipment or income among persons when not for fair market value under an length agreement, shall be a prima facie case that one person controls another person. A person who knowingly convicted of a public entity crime, in Florida during the preceding 36 months shall be considered an affiliate.
7. I understand that a "person" as defined in paragraph 287 .133 (1) (e), Florida Statutes, means any natural person or entity organized under the laws of the state or of the United States with the legal power to enter into a binding contract provision of goods or services let by a public entity, or which otherwise transacts or applies to transact business with a public entity. The term "person" includes those officers, directors, executives, partners, shareholders, employees, members, and agents who are active in management of an entity.
8. Based on information and belief, the statement which I have marked below is true in relation to the entity submitting this sworn statement. (Please indicate which statement applies)

- Neither the entity submitting this sworn statement, nor any officers, directors, executive, partners, shareholders, employees, member, or agents who are active in management of the entity, nor affiliate of the entity have been charged with and convicted of a public entity crime subsequent to July 1, 1989.
- The entity submitting this sworn statement, or one or more of the officers, directors, executives, partners, shareholders, employees, members, or agents who are active in management of the entity, or an affiliate of the entity has been charged with and convicted of a public entity crime subsequent to July 1, 1989 And (please attach a copy of the final order)
- The person or affiliate was placed on the convicted vendor list. There has been a subsequent proceeding before a hearing officer of the State of Florida, Division of Administrative Hearings. The final order entered by the hearing officer determined that it was in public interest to remove the person or affiliate from the convicted vendor list. (Please attach a copy of the final order)
- The person or affiliate has not been placed on the convicted vendor list. (Please describe any action taken by, or pending with, the department of General Services)

I UNDERSTAND THAT THE SUBMISSION OF THIS FORM TO THE CONTRACTING OFFICER FOR THE PUBLIC ENTITY IDENTIFIED IN PARAGRAPH 1 (ONE) ABOVE IS FOR THAT PUBLIC ENTITY ONLY AND THAT THIS FORM IS VALID THROUGH DECEMBER 31 OF THE CALENDAR YEAR IN WHICH IT IS FILED. I ALSO UNDERSTAND THAT I AM REQUIRED TO INFORM THE PUBLIC ENTITY PRIOR TO ENTERING INTO A CONTRACT IN EXCESS OF THE THRESHOLD AMOUNT PROVIDED IN SECTION 287.017, FLORIDA STATUTES FOR CATEGORY TWO OF ANY CHANGE IN THE INFORMATION CONTAINED IN THIS FORM

Joshua M. Livingston
Name

[Handwritten Signature]
Signature

3-2-22
Date

PERSONALLY APPEARED BEFORE ME, the undersigned authority, who, after first being sworn by me, affixed his/her signature at the space provided above on this day of 2 March 2022, and is personally known to me, or has provided Drivers license as identification.

STATE OF FLORIDA
COUNTY OF: OKALOOSA
My Commission expires: 08/18/2024

[Handwritten Signature]
Notary Public

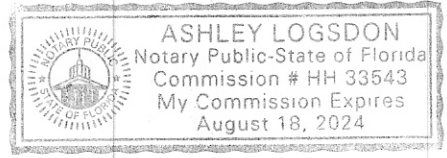

I will construct this project for the lump sum price of:

Navarre Beach Boat Ramp Private Aids to Navigation					
Bid Form					
Item No.	Item Description	Item Qty.	Qty. Unit	Unit Price	Extended Amount
GENERAL					
G-1	Mobilization	1	LS	8,000. ⁰⁰	8,000. ⁰⁰
G-2	Turbidity Curtains Per Permit Req. (Includes Testing & Monitoring)	1	LS	5,000. ⁰⁰	5,000. ⁰⁰
G-3	Provide As-Built Drawings (Includes Lat./Long.)	1	LS	1,500. ⁰⁰	1,500. ⁰⁰
PATON INSTALLATION					
1-1	Port-Side Channel Markers w/ Lantern	5	EA	6,650. ⁰⁰	33,250
1-2	Port-Side Channel Markers w/o Lantern	2	EA	6,150. ⁰⁰	12,300
1-3	Starboard-Side Channel Markers w/ Lantern	4	EA	6,650. ⁰⁰	26,600
1-4	Starboard Channel Markers w/o Lantern	2	EA	6,150. ⁰⁰	12,300
Total Bid					98,950. ⁰⁰

This is a lump sum project. The purpose for providing a bid tabulation (if this is included in the bid package by engineer) format is to provide unit prices in case of change order. There is no implied statement by the engineer or Santa Rosa County as to the accuracy of the stated quantities within the bid tab or that the bid tab is all inclusive of the work items within the plans. It is the contractor's responsibility to carefully review the plans, specifications, and project to determine what is needed to do the whole job, and to reflect this in his LUMP SUM BID. This basis of award will be the total base bid for the project.

This project requires a permit which must be acquired by the contractor. Associated fees, for a final fixed price shall be disclosed in your respective scope of work including fee amounts, the issuing entity and if fees shall be paid prior to commencement of work.

FIRM: Complete Site Source

BY (print): Josh Livingston

SIGNATURE: 

TITLE: General Contractor

DATE: 3-2-22

MAILING ADDRESS 212 Lakeside Ln

Mary Esther, FL 32569

PHONE (850) 572-6907 FAX () _____

EMAIL Complete Site Source@gmail.com

CONE OF SILENCE FORM

The Board of County Commissioners have established a solicitation silence policy (Cone of Silence) that prohibits oral and written communication regarding all formal solicitations for goods and services (ITB, RFP, ITQ, ITN, and RFQ) or other competitive solicitation between the bidder (or its agents or representatives) or other entity with the potential for a financial interest in the award (or their respective agents or representatives) regarding such competitive solicitation, and any County Commissioner or County employee, selection committee member or other persons authorized to act on behalf of the Board including the County's Architect, Engineer or their sub-consultants, or anyone designated to provide a recommendation to award a particular contract, other than the Procurement Department Staff.

The period commences from the time of advertisement until contract award.

Any information thought to affect the committee or staff recommendation submitted after bids are due, should be directed to the Procurement Officer or an appointed representative. It shall be the Procurement Officers decision whether to consider this information in the decision process.

Any violation of this policy shall be grounds to disqualify the respondent from consideration during the selection process.

All respondents must agree to comply with this policy by signing the following statement and including it with their submittal.

I, Josh Livingston representing Complete Site Source
(Print) (Company)

On this 2 day of March 2022 hereby agree to abide by the County's "Cone of Silence" clause and understand violation of this policy shall result in disqualification of my proposal/submittal.

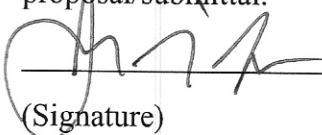
(Signature)

DEBARMENT FORM

Certification Regarding Debarment, Suspension, And Other Responsibility Matters

1. The prospective primary participant certifies to the best of its knowledge and belief, that it and its principals:
 - a. Are not presently debarred, suspended, proposed for debarment, declared ineligible, or voluntarily excluded from covered transactions by any Federal department or agency;
 - b. Have not within a three-year period preceding this proposal been convicted of or had a civil judgment rendered against them for commission of fraud or a criminal offense in connection with obtaining, attempting to obtain, or performing a public (Federal, State or Local) transaction or contract under a public transaction; violation of Federal or State antitrust statutes or commission of embezzlement, theft, forgery, bribery, falsification or destruction of records, making false statements, or receiving stolen property;
 - c. Are not presently indicted for or otherwise criminally or civilly charged by a governmental entity (Federal, State, or Local) with commission of any of the offenses enumerated in paragraph (1)(b) of this certification; and
 - d. Have not within a three-year period preceding this application/proposal had one or more public transactions (Federal, State, or Local) terminated for cause or default.
2. Where the prospective primary participant is unable to certify to any of the statements in this certification, such prospective participant shall attach an explanation to this proposal.

Name: Josh Livingston Title: General Contractor

Signature: 

Firm: Complete Site Source

Street Address: 212 Lakeside Ln

City: Mary Esther

State: FL Zip Code: 32569

Solicitation Name: Navarre Beach Boat Ramp Private Aids to Navigation # 22-017

REFERENCES FORM

List work which best illustrates current qualifications relevant to this solicitation accomplished by personnel that will be assigned to the County's project. List at least three but no more than five (5) projects. (This form may be reproduced.)

YOUR FIRMS NAME Complete Site Source
PROPOSAL POINT OF CONTACT Josh Livingston PHONE 850-572-6907
EMAIL complete.sitesource@gmail.com

REFERENCE I.

PROJECT NAME: Okaloosa County No wake Piling & Sign replacement
AGENCY: Okaloosa County
ADDRESS: 1540 Miracle Strip PKWY
CITY, STATE, ZIP CODE: Ft. Walton Bch, FL 32548
CONTACT PERSON: Alex Fogg
TITLE: Coastal Resource Manager
EMAIL: Afogg@myokaloosa.com
TELEPHONE: 850-609-5394
PROJECT COST: 12,430.00
COMPLETION DATE: 1-19-22

SCOPE of Project (list tasks, attach samples of deliverables, outlines or descriptions of items:
(You may attach information to this form)

6 Piling installation, 8 no wake sign installation. Contractor followed the FL Fish & Wildlife's Technical Specifications for instal & removal.

List key personnel assigned to this project that will work on the County project (include assignments. You may attach information to this form):

Josh Livingston: General Contractor, Don Livingston,
Joe Livingston, Eldrin Burns

REFERENCE II.

PROJECT NAME: Big Dawg Vessel Preparation & Deployment
AGENCY: Okaloosa County
ADDRESS: 1540 Miracle Strip PKWY
CITY, STATE, ZIP CODE: Ft. Walton Bch. FL 32548
CONTACT PERSON: Alex Fogg
TITLE: Coastal Resource Manager
EMAIL: Afogg@myokaloosa.com
TELEPHONE: 850-609-5394
PROJECT COST: 92,400.00

COMPLETION DATE: 5-10-21

SCOPE of Project (list tasks, attach samples of deliverables, outlines or descriptions of items:
(You may attach information to this form)

Cleaned + Removed all exterior of 160-ft vessel for artificial reef.
Once inspected towed vessel off shore + sank vessel.

List key personnel assigned to this project that will work on the County project (include assignments. You may attach information to this form):

Josh Livingston - General Contractor, Don Livingston,
Joe Livingston, Eldrin Burns

REFERENCE III.

PROJECT NAME: The Shack Marina Piling Installation

AGENCY: The Shack Marina,

ADDRESS: 104 Miracle Strip PKWY SW

CITY, STATE, ZIP CODE: Ft. Walton Bch, FL 32548

CONTACT PERSON: Jim + Laurie Pearson

TITLE: Managers

EMAIL: laurie@crabshackmarina.com

TELEPHONE: 850-244-5725

PROJECT COST: 12,500.⁰⁰

COMPLETION DATE: 1-10-22

SCOPE of Project (list tasks, attach samples of deliverables, outlines or descriptions of items:
(You may attach information to this form)

Breakwall installation, Piling installation

List key personnel assigned to this project that will work on the County project (include assignments. You may attach information to this form):

Josh Livingston, Don Livingston, Joe Livingston,
Eldrin Burns

CONFLICT OF INTEREST DISCLOSURE FORM

For purposes of determining any possible conflict of interest, all respondents, must disclose if any Santa Rosa Board of County Commissioner, employee(s), elected officials(s), or if any of its agencies is also an owner, corporate officer, agency, employee, etc., of their business.

Indicate either "yes" (a county employee, elected official, or agency is also associated with your business), or "no". If yes, give person(s) name(s) and position(s) with your business.

Yes: _____ No: X

Name(s)

Position(s)

All respondents must agree to comply with this policy by signing the following statement and including it with their submittal.

FIRM NAME: Complete Site Source

BY (PRINTED): Josh Livingston

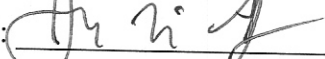
BY (SIGNATURE): 

TITLE: General Contractor

ADDRESS: 212 Lakeside Ln. Mary Esther State FL Zip Code 32569

PHONE NO: 850-572-6907

E-MAIL: completesitesource@gmail.com

Date: 3-2-22



COMPSIT-01

MELMER

CERTIFICATE OF LIABILITY INSURANCE

DATE (MM/DD/YYYY)

1/24/2022

THIS CERTIFICATE IS ISSUED AS A MATTER OF INFORMATION ONLY AND CONFERS NO RIGHTS UPON THE CERTIFICATE HOLDER. THIS CERTIFICATE DOES NOT AFFIRMATIVELY OR NEGATIVELY AMEND, EXTEND OR ALTER THE COVERAGE AFFORDED BY THE POLICIES BELOW. THIS CERTIFICATE OF INSURANCE DOES NOT CONSTITUTE A CONTRACT BETWEEN THE ISSUING INSURER(S), AUTHORIZED REPRESENTATIVE OR PRODUCER, AND THE CERTIFICATE HOLDER.

IMPORTANT: If the certificate holder is an ADDITIONAL INSURED, the policy(ies) must have ADDITIONAL INSURED provisions or be endorsed. If SUBROGATION IS WAIVED, subject to the terms and conditions of the policy, certain policies may require an endorsement. A statement on this certificate does not confer rights to the certificate holder in lieu of such endorsement(s).

PRODUCER Hub International Gulf South 1311 Spring Street, Suite A Gulfport, MS 39503	CONTACT NAME: PHONE (A/C, No, Ext): (228) 897-6700		FAX (A/C, No): (228) 897-6711
	E-MAIL ADDRESS:		
INSURED Complete Site Source, LLC 212 Lakeside Lane Mary Esther, FL 32569	INSURER(S) AFFORDING COVERAGE		NAIC #
	INSURER A : Nautilus Insurance Company		17370
	INSURER B : Amfed Casualty Insurance Company		11963
	INSURER C :		
	INSURER D :		
	INSURER E :		

COVERAGES **CERTIFICATE NUMBER:** **REVISION NUMBER:**

THIS IS TO CERTIFY THAT THE POLICIES OF INSURANCE LISTED BELOW HAVE BEEN ISSUED TO THE INSURED NAMED ABOVE FOR THE POLICY PERIOD INDICATED. NOTWITHSTANDING ANY REQUIREMENT, TERM OR CONDITION OF ANY CONTRACT OR OTHER DOCUMENT WITH RESPECT TO WHICH THIS CERTIFICATE MAY BE ISSUED OR MAY PERTAIN, THE INSURANCE AFFORDED BY THE POLICIES DESCRIBED HEREIN IS SUBJECT TO ALL THE TERMS, EXCLUSIONS AND CONDITIONS OF SUCH POLICIES. LIMITS SHOWN MAY HAVE BEEN REDUCED BY PAID CLAIMS.

INSR LTR	TYPE OF INSURANCE	ADDL INSD	SUBR WVD	POLICY NUMBER	POLICY EFF (MM/DD/YYYY)	POLICY EXP (MM/DD/YYYY)	LIMITS	
A	<input checked="" type="checkbox"/> COMMERCIAL GENERAL LIABILITY <input type="checkbox"/> CLAIMS-MADE <input checked="" type="checkbox"/> OCCUR GEN'L AGGREGATE LIMIT APPLIES PER: <input checked="" type="checkbox"/> POLICY <input type="checkbox"/> PRO-JECT <input type="checkbox"/> LOC OTHER:			NN1320272	10/1/2021	10/1/2022	EACH OCCURRENCE	\$ 1,000,000
		DAMAGE TO RENTED PREMISES (Ea occurrence)	\$ 100,000					
		MED EXP (Any one person)	\$ 5,000					
		PERSONAL & ADV INJURY	\$ 1,000,000					
		GENERAL AGGREGATE	\$ 2,000,000					
		PRODUCTS - COMP/OP AGG	\$ 2,000,000					
			\$					
	<input type="checkbox"/> AUTOMOBILE LIABILITY <input type="checkbox"/> ANY AUTO OWNED AUTOS ONLY <input type="checkbox"/> SCHEDULED AUTOS <input type="checkbox"/> HIRED AUTOS ONLY <input type="checkbox"/> NON-OWNED AUTOS ONLY						COMBINED SINGLE LIMIT (Ea accident)	\$
							BODILY INJURY (Per person)	\$
							BODILY INJURY (Per accident)	\$
							PROPERTY DAMAGE (Per accident)	\$
								\$
	<input type="checkbox"/> UMBRELLA LIAB <input type="checkbox"/> OCCUR <input type="checkbox"/> EXCESS LIAB <input type="checkbox"/> CLAIMS-MADE DED RETENTION \$						EACH OCCURRENCE	\$
							AGGREGATE	\$
								\$
B	WORKERS COMPENSATION AND EMPLOYERS' LIABILITY ANY PROPRIETOR/PARTNER/EXECUTIVE OFFICER/MEMBER EXCLUDED? (Mandatory in NH) If yes, describe under DESCRIPTION OF OPERATIONS below	Y/N	N/A	WC121-6005773	7/16/2021	7/16/2022	<input checked="" type="checkbox"/> PER STATUTE <input type="checkbox"/> OTH-ER	
							E.L. EACH ACCIDENT	\$ 1,000,000
							E.L. DISEASE - EA EMPLOYEE	\$ 1,000,000
							E.L. DISEASE - POLICY LIMIT	\$ 1,000,000

DESCRIPTION OF OPERATIONS / LOCATIONS / VEHICLES (ACORD 101, Additional Remarks Schedule, may be attached if more space is required)
Workers Compensation includes US Longshore & Harbor coverage.

Contractor License #CBC1264507

CERTIFICATE HOLDER

CANCELLATION

SHOULD ANY OF THE ABOVE DESCRIBED POLICIES BE CANCELLED BEFORE THE EXPIRATION DATE THEREOF, NOTICE WILL BE DELIVERED IN ACCORDANCE WITH THE POLICY PROVISIONS.

AUTHORIZED REPRESENTATIVE



[Department of State](#) / [Division of Corporations](#) / [Search Records](#) / [Search by Entity Name](#) /

Detail by Entity Name

Florida Limited Liability Company
COMPLETE SITE SOURCE LLC

Filing Information

Document Number	L19000224980
FEI/EIN Number	84-3094884
Date Filed	09/05/2019
Effective Date	09/06/2019
State	FL
Status	ACTIVE

Principal Address

212 LAKESIDE LN
MARY ESTHER, FL 32569

Mailing Address

212 LAKESIDE LN
MARY ESTHER, FL 32569

Registered Agent Name & Address

LIVINGSTON, DON C, III
212 LAKESIDE LN
MARY ESTHER, FL 32569

Authorized Person(s) Detail

Name & Address

Title Owner

Livingston, Don Carl, III
212 Lakeside Ln
Mary Esther, FL 32569

Annual Reports

Report Year	Filed Date
2020	01/14/2020
2021	01/31/2021

Document Images

[01/31/2021 -- ANNUAL REPORT](#)

[View image in PDF format](#)

Insurance Company: **Great American Insurance Group**
Administered by: Gallagher Charter Lakes

Policy Number: **GPV0000064**

This policy will take effect on: 1/30/2022 and will end on: 1/30/2023
beginning and ending at 12:01 am EST.



COMMERCIAL MARINE INSURANCE – Policy Declarations Page

Renewal:

Named Insured Under This Policy:

Agency Name & Address:

Joshua Livingston dba Dreadknot Charters 703 Bayou Dr Destin, FL 32541-1802	GALLAGHER CHARTER LAKES 3940 Peninsular Drive SE, Ste 100 Grand Rapids, MI 49546-6107
--	---

Insured Property:

Name	Year	Length	Make	Model	Hull ID #
Dreadknot II	2010	39	Louisiana Homemade		LAZ70622D010

Insured Dinghy(s):

Year	Length	Make	Serial #

Insured Trailer(s):

Year	Make	Serial #
2010	EZ Loader	TST663257SPLA

This declarations page and any endorsements are to be inserted in and form part of your policy. If a change effective date appears at the top of the declarations, then this declarations page replaces any previous declarations on that date. This policy provides only the insurance for which a specific premium charge is indicated below, or which is indicated as included without specific charge either below, in your policy, or as indicated by endorsement.

Parts	Coverages	Amount of Insurance	Elected Deductible	Premium	Endorsements
A	Physical Damage-Agreed Value	120,000	12,000	\$2,578.00	Additional Insured Additional Insured w/WOS Captain & Crew (2) Dive Boat
B	Liability Coverage	1,000,000	2,500	\$1,500.00	
C	Medical Payments	25,000	0	Included	
F	Personal Property	2,500	250	Included	
D	Uninsured Boater	1,000,000	2,500	Included	
E	Trailer	5,000	250	\$75.00	
A	Towing	2,500	0	Included	
B	Pollution Liability	1,000,000	2,500	Included	
	Endorsements/Charges	0	0	\$1,450.00	
Unit Premium:				\$5,603.00	

Loss Payee: We will make payment for part A physical damage to the Insured and:

Navigation Limits:

Warranted confined to the Gulf of Mexico and navigable tributary waters of the United States between Carrabelle, FL and Brownsville, TX, not to exceed 75 miles offshore.

Layup Warranty: 12 Month Navigation

The insured vessel will be principally moored or berthed at:

Residence, 703 Bayou Dr, Destin, FL, 32541-1802

Countersigned 12/13/2021, at Grand Rapids, MI by:

, Agent.

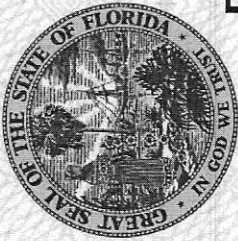

Ron DeSantis, Governor

Melanie S. Griffin, Secretary



STATE OF FLORIDA
DEPARTMENT OF BUSINESS AND PROFESSIONAL REGULATION

CONSTRUCTION INDUSTRY LICENSING BOARD

THE BUILDING CONTRACTOR HEREIN IS CERTIFIED UNDER THE
PROVISIONS OF CHAPTER 489, FLORIDA STATUTES

LIVINGSTON, JOSHUA MICHAEL

COMPLETE SITE SOURCE LLC
212 LAKESIDE LANE
MARY ESTHER FL 32569

LICENSE NUMBER: CBC1264507

EXPIRATION DATE: AUGUST 31, 2022

Always verify licenses online at MyFloridaLicense.com



Do not alter this document in any form.

This is your license. It is unlawful for anyone other than the licensee to use this document.

Exhibit B

Santa Rosa County
Standard Insurance Requirements
March 2021

Workers' Compensation – meet statutory limits in compliance with the Workers Compensation Laws of Florida. This policy must include Employer Liability with a limit of \$100,000 for each accident, \$500,000 disease policy limit and \$100,000 disease each employee limit.

Commercial General Liability – coverage shall provide minimum limits of liability of \$1,000,000 per occurrence, \$2,000,000 Aggregate, for bodily injury and property damage. This shall include coverage for:

- a. Premises/operations
- b. Products/complete operations
- c. Contractual liability
- d. Independent contractors

Business Auto Liability – coverage shall provide minimum limits \$500,000. Combined Single Limit for bodily injury and property damage. If Split limit coverage is provided Limits of 500,000 per person/500,000 per accident and 500,000 for property damage are required.

This shall include coverage for:

- a. Owned autos
- b. Hired autos
- c. Non-owned autos

Special Requirements:

- 1) Prior to execution of a contract or agreement, certificates of insurance will be produced that shall provide for the following:
 - a. Santa Rosa County shall be named as an additional insured on all coverages except workers' compensation.
 - b. Santa Rosa County will be given thirty (30) days' notice prior to cancellation or modification of any stipulated insurance.

2) It is the responsibility of the contractor to ensure that all subcontractors comply with all insurance requirements.

3) It should be noted that these are minimum requirements which are subject to modification in response to specialized or high hazard operations.

In the event of unusual circumstances, the County Administrator, or his designee, may adjust these insurance requirements

Exhibit C- Civil Rights Clauses

Title VI List of Pertinent Nondiscrimination Acts and Authorities

During the performance of this Agreement, the Contractor, for itself, its assignees, and successors in interest (hereinafter referred to as the “Contractor”), as applicable, agrees to comply with the following non-discrimination statutes and authorities; including but not limited to:

- Title VI of the Civil Rights Act of 1964 (42 USC § 2000d *et seq.*, 78 stat. 252) (prohibits discrimination on the basis of race, color, national origin);
- 49 CFR part 21 (Non-discrimination in Federally-assisted programs of the Department of Transportation—Effectuation of Title VI of the Civil Rights Act of 1964);
- The Uniform Relocation Assistance and Real Property Acquisition Policies Act of 1970, (42 USC § 4601) (prohibits unfair treatment of persons displaced or whose property has been acquired because of Federal or Federal-aid programs and projects);
- Section 504 of the Rehabilitation Act of 1973 (29 USC § 794 *et seq.*), as amended (prohibits discrimination on the basis of disability); and 49 CFR part 27;
- The Age Discrimination Act of 1975, as amended (42 USC § 6101 *et seq.*) (prohibits discrimination on the basis of age);
- Airport and Airway Improvement Act of 1982 (49 USC § 471, Section 47123), as amended (prohibits discrimination based on race, creed, color, national origin, or sex);
- The Civil Rights Restoration Act of 1987 (PL 100-209) (broadened the scope, coverage and applicability of Title VI of the Civil Rights Act of 1964, the Age Discrimination Act of 1975 and Section 504 of the Rehabilitation Act of 1973, by expanding the definition of the terms “programs or activities” to include all of the programs or activities of the Federal-aid recipients, sub-recipients and contractors, whether such programs or activities are Federally funded or not);
- Titles II and III of the Americans with Disabilities Act of 1990, which prohibit discrimination on the basis of disability in the operation of public entities, public and private transportation systems, places of public accommodation, and certain testing entities (42 USC §§ 12131 – 12189) as implemented by U.S. Department of Transportation regulations at 49 CFR parts 37 and 38;
- The Federal Aviation Administration’s Nondiscrimination statute (49 USC § 47123) (prohibits discrimination on the basis of race, color, national origin, and sex);
- Executive Order 12898, Federal Actions to Address Environmental Justice in Minority Populations and Low-Income Populations, which ensures nondiscrimination against minority populations by discouraging programs, policies, and activities with disproportionately high and adverse human health or environmental effects on minority and low-income populations;
- Executive Order 13166, Improving Access to Services for Persons with Limited English Proficiency, and resulting agency guidance, national origin discrimination includes discrimination because of limited English proficiency (LEP). To ensure compliance with Title VI, you must take reasonable steps to ensure that LEP persons have meaningful access to your programs (70 Fed. Reg. at 74087 to 74100);
- Title IX of the Education Amendments of 1972, as amended, which prohibits you from discriminating because of sex in education programs or activities (20 USC 1681 *et seq.*).

Exhibit D
VENDORS ON SCRUTINIZED COMPANIES LISTS

By executing this Certificate, the bid proposer, certifies that it is not: (1) listed on the Scrutinized Companies that Boycott Israel List, created pursuant to section 215.4725, Florida Statutes, (2) engaged in a boycott of Israel, (3) listed on the Scrutinized Companies with Activities in Sudan List or the Scrutinized Companies with Activities in the Iran Petroleum Energy Sector List, created pursuant to section 215.473, Florida Statutes, or (4) engaged in business operations in Cuba or Syria. Pursuant to section 287.135(5), Florida Statutes, the County may disqualify the bid proper immediately or immediately terminate any agreement entered into for cause if the bid proposer is found to have submitted a false certification as to the above or if the Contractor is placed on the Scrutinized Companies that Boycott Israel List, is engaged in a boycott of Israel, has been placed on the Scrutinized Companies with Activities in Sudan List or the Scrutinized Companies with Activities in the Iran Petroleum Energy Sector List, or has been engaged in business operations in Cuba or Syria, during the term of the Agreement. If the County determines that the bid proposer has submitted a false certification, the County will provide written notice to the bid proposer. Unless the bid proposer demonstrates in writing, within 90 calendar days of receipt of the notice, that the County's determination of false certification was made in error, the County shall bring a civil action against the bid proposer. If the County's determination is upheld, a civil penalty shall apply, and the bid proposer will be ineligible to bid on any Agreement with a Florida agency or local governmental entity for three years after the date of County's determination of false certification by bid proposer.

As the person authorized to sign this statement, I certify that this firm complies fully with the above requirements.

DATE: March 16, 22

SIGNATURE: 

COMPANY: Complete Site Source

NAME: Josh Livingston
(Typed or Printed)

ADDRESS: 212 Lakeside Ln
Mary Esther, FL 32569

TITLE: General Contractor

E-MAIL: completesitesource@gmail.com

PHONE NO.: 850-572-6907