

ARLINGTON COUNTY, VIRGINIA
OFFICE OF THE PURCHASING AGENT
2100 CLARENDON BOULEVARD, SUITE 500
ARLINGTON, VIRGINIA 22201

CONTRACT RENEWAL

TO: SAGRES CONSTRUCTION CORPORATION
3680 WHEELER AVENUE, SUITE 300
ALEXANDRIA, VA 22304

ORIGINAL DATE ISSUED:

OCTOBER 2, 2019

CONTRACT NO:

19-279-ITB

CONTRACT TITLE:

ON-CALL CONSTRUCTION OF
WET UTILITIES

AMENDMENT NO:

1

THIS IS A NOTICE OF RENEWAL AND NOT AN ORDER. NO WORK IS AUTHORIZED UNTIL THE VENDOR RECEIVES A VALID COUNTY PURCHASE ORDER ENCUMBERING CONTRACT FUNDS.

The contract documents consist of the terms and conditions of AGREEMENT No. 19-279-ITB including any attachments or amendments thereto.

EFFECTIVE DATE: SEPTEMBER 30, 2021

EXPIRES: SEPTEMBER 29, 2022

RENEWALS: THERE ARE TWO (2) ONE (1) YEAR RENEWALS REMAINING, FROM SEPTEMBER 30, 2022 TO SEPTEMBER 29, 2024

COMMODITY CODE(S): 91319, 91339, 91345, 91360

LIVING WAGE: N

PROFESSIONAL SERVICES: N

ATTACHMENTS:

AGREEMENT No. 19-279-ITB

EMPLOYEES NOT TO BENEFIT:

NO COUNTY EMPLOYEE SHALL RECEIVE ANY SHARE OR BENEFIT OF THIS CONTRACT NOT AVAILABLE TO THE GENERAL PUBLIC.

VENDOR CONTACT: DEJAN DRAGACEVAC

VENDOR TEL. NO.:

(703) 924-7220

EMAIL ADDRESS: DAN@SAGRESCONSTRUCTION.COM

COUNTY CONTACT: NILESH NAIKARE

COUNTY TEL. NO.:

(703) 228-3632

COUNTY CONTACT EMAIL: Nnaikare@arlingtonva.us

CONTRACT AUTHORIZATION

ARLINGTON COUNTY, VIRGINIA

**AGREEMENT NO. 19-279-ITB
AMENDMENT NUMBER 1**

This **Amendment Number 1** is made on **September 27, 2021** by the County and amends Agreement Number 19-279-ITB (“Main Agreement”) dated October 2, 2019 between **Sagres Construction Corporation** (“Contractor”) and the **County Board of Arlington County, Virginia** (“County”).

The County and the Contractor agree to amend the Main Agreement as follows:

Section 1: **Contract Documents**

The following Contract Documents are hereby **added**:

- Attachment M – Arlington County Invitation to Bid No. 19-279-ITB, including DES General Conditions, Special Conditions, and Supplementary Specifications, incorporated herein by reference.
- Attachment N – Drawings for HDPE Connection to RCP and Mulch and Mat Detail
- Attachment O – Contractor COVID-19 Vaccination Certification

Section 50: **Notices**: remove Kamal Taktak, Project Officer and replace with:

Nilesh Naikare, Project Officer
Arlington County
Department of Environmental Services
2100 Clarendon Blvd, Suite 800
Arlington, VA, 22201
Phone: 703-228-7595
Email: nnaikari@arlingtonva.us

Section 53: **COVID-19 VACCINATION POLICY FOR CONTRACTORS** is hereby **added**:

Due to the ongoing COVID-19 pandemic, the County has taken various steps to protect the welfare, health, safety, and comfort of the workforce and public at large. As part of these steps, the County has implemented various requirements with respect to health and safety including policies with respect to social distancing, the use of face-coverings and vaccine mandates. To protect the County’s workforce and the public at large, all employees and subcontractors of the Contractor who are assigned to this Contract, must be fully vaccinated against COVID-19. Any contractor employee or subcontractor who is not fully vaccinated should be following a weekly testing protocol as established by the Contractor, unless exempt pursuant to a valid reasonable accommodation under state or federal law. Contractor should submit the certification of compliance to the Purchasing Agent at the time of contract execution.

All other terms and conditions of the Main Agreement remain in effect.

WITNESS these signatures:

THE COUNTY BOARD OF ARLINGTON

COUNTY, VIRGINIA

AUTHORIZED: DocuSigned by:
SIGNATURE: *Sy Gezachew*
27FC198F4A6D475...

NAME: SY GEZACHEW

TITLE: PROCUREMENT OFFICER

DATE: 10/7/2021

SAGRES CONSTRUCTION CORPORATION

AUTHORIZED: DocuSigned by:
SIGNATURE: *Dejan Dragacevac*
817420F7C4EC427...

NAME: Dejan Dragacevac

TITLE: Vice President

DATE: 10/7/2021

ATTACHMENT M

ARLINGTON COUNTY, VIRGINIA
OFFICE OF THE PURCHASING AGENT
2100 CLARENDON BOULEVARD, SUITE 500
ARLINGTON, VA 22201
(703) 228-3410

INVITATION TO BID NO. 19-279-ITB

SEALED BIDS WILL BE RECEIVED IN HAND IN THE OFFICE OF THE BID CLERK, SUITE 511, 2100 CLARENDON BOULEVARD, ARLINGTON, VIRGINIA 22201, ON JUNE 4, 2019 AT 2:00 P.M., LOCAL TIME FOR THE FOLLOWING WORK:

CONSTRUCTION OF WET UTILITIES (STORM/SANITARY/WATER MAINS) AND ASSOCIATED OUTFALL AND STREAM CHANNEL IMPROVEMENT ON AN ON-CALL BASIS FOR IN ARLINGTON COUNTY TO INCLUDE:

- STORM SEWER PIPES AND INLETS
- WATER MAINS
- SANITARY SEWER PIPES AND STRUCTURES
- CURBS AND GUTTERS
- SIDEWALKS AND WALKWAYS
- DRIVEWAY APRONS
- PAVEMENT MARKINGS AND SIGNAGE
- STREETScape,
- REGENERATIVE STORMWATER CONVEYANCES (RSC'S)
- STREAM CHANNEL REPAIR, AND
- RELATED WORK.

At the time, date and place stated above, bids will be publicly opened.

Bid Surety in the amount of not less fifty thousand dollars (\$50,000) must be submitted with the bid. Performance and Payment Bonds in the amount of one million dollars (\$1,000,000.00) will be required of the successful Bidder.

NOTICE: ANY BIDDER ORGANIZED AS A STOCK OR NONSTOCK CORPORATION, LIMITED LIABILITY COMPANY, BUSINESS TRUST, OR LIMITED PARTNERSHIP OR REGISTERED AS A LIMITED LIABILITY PARTNERSHIP MUST BE AUTHORIZED TO TRANSACT BUSINESS IN THE COMMONWEALTH OF VIRGINIA PRIOR TO SUBMITTING A BID (REFER TO AUTHORITY TO TRANSACT BUSINESS SECTION IN THE SOLICITATION FOR FURTHER INFORMATION)

Arlington County reserves the right to reject any and all bids, cancel this solicitation and to waive any informalities or irregularities in procedure. A Bidder's submission of a bid indicates acceptance of these terms.

Arlington County, Virginia
Office of the Purchasing Agent
Igor Scherbakov
Procurement Officer
ischerbakov@arlingtonva.us

TABLE OF CONTENTS

I.	INSTRUCTIONS TO BIDDERS.....	3
II.	SPECIAL CONDITIONS	15
III.	SUPPLEMENTAL SPECIFICATIONS.....	37
IV.	AGREEMENT AND CONTRACT TERMS AND CONDITIONS.....	123
V.	ARLINGTON COUNTY DES ENGINEERING PROJECT GENERAL CONDITIONS.....	137
VI.	INSURANCE REQUIREMENTS	180
VII.	ATTACHMENTS AND FORMS.....	189
	BID FORM.....	200
	ATTACHMENT A - PRICE SCHEDULE	
	ATTACHMENT B – MASTER TRANSPORTATION PLAN	
	ATTACHMENT C – LANE CLOSURES IN NOVA DISTRICT	
	ATTACHMENT D – STATE AND FEDERAL ROADS IN ARLINGTON COUNTY, VIRGINIA	
	ATTACHMENT E – ARLINGTON COUNTY, VIRGINIA MATERIALS TESTING SPECIFICATION REFERENCE GUIDE	
	ATTACHMENT F – POLYPROPYLENE PIPE DETAIL	
	ATTACHMENT G – BIODEGRADABLE TREE SHELTER	
	ATTACHMENT H – POLYPROPYLENE TREE SHELTER	
	ATTACHMENT I – LIVE STAKES	
	ATTACHMENT J – SAMPLE PROJECTS	
	ATTACHMENT K – REVISED ARLINGTON COUNTY STANDARD DETAIL M-6.0	

I. INSTRUCTIONS TO BIDDERS

1. ADDITIONAL INFORMATION

All communications relating to this solicitation shall be submitted via e-mail to **Igor Scherbakov** in the Office of the Purchasing Agent, at **ischerbakov@arlingtonva.us**.

For a question to be considered, the subject line of the e-mail must state the following: **ITB No. 19-279-ITB Questions**.

Questions should be succinct and must include the submitter's name, title, company name, company address, and telephone number. Prior to the award of a contract resulting from this solicitation, Bidders are prohibited from contacting any County staff other than those assigned to the Office of the Purchasing Agent.

ALL QUESTIONS MUST BE SUBMITTED ON OR BEFORE MAY 21, 2019 AT 5:00 P.M., LOCAL TIME. ONLY RESPONSES TO QUESTIONS SUBMITTED ON OR BEFORE THE ABOVE DATE WILL BE ADDRESSED IN AN ADDENDUM TO THE SOLICITATION. If any questions or responses require revisions to this solicitation as it was originally published, such revisions will be by formal Addendum only.

Bidders are cautioned that any written, electronic, or oral representation made by any County representative or other person that appear to change materially any portion of the solicitation **shall not be relied upon unless subsequently ratified by a written Addendum to this solicitation issued by the Office of the Purchasing Agent.**

2. COMPETITION INTENDED

It is the County's intent that this solicitation promotes competition. It shall be the Bidder's responsibility to advise Arlington County if any language, requirements or specifications restrict or limit the purchase to a single source.

Such notification must be received by the Arlington County Purchasing Agent not later than Fifteen (15) calendar days prior to the date and time set for bid opening. A review of such notifications will be made and the Bidder notified of the results of the review.

3. BID FORM SUBMISSION

The required Bid Form is provided in the solicitation. One (1) fully-completed Bid Form with an original longhand signature, and One (1) photocopy of the signed original Bid Form shall be submitted by hand, in a sealed envelope or package, to the Office of the Bid Clerk, Suite 511, 2100 Clarendon Boulevard, Arlington, Virginia, 22201, no later than the date and time deadline specified in the Invitation to Bid above.

Timely submission is solely the responsibility of the Bidder. Bid Forms received after the specified date and time will be rejected. The exterior of the envelope or package shall indicate the name of the Bidder, the scheduled bid opening date and time, and the number of the Invitation to Bid. Bids submitted by facsimile or electronically will not be accepted.

A Bidder's failure to submit a bid with a fully-completed Bid Form, using the Bid Form provided in this solicitation, shall be cause for rejection of that Bidder's bid. **A bid will be rejected if its corresponding Bid Form is not signed in the designated space by a person authorized to legally bind the Bidder.**

Modifications of or additions to the Bid Form may be cause for rejection of the bid. Arlington County reserves the right to decide, on a case by case basis, in its sole discretion, whether or not to reject such a bid as nonresponsive.

As a pre-condition to bid acceptance, Arlington County may, in its sole discretion, request that the Bidder withdraw or modify any such modifications or additions which do not affect quality, quantity, price, or delivery. Bids and all documents related to this solicitation submitted to Arlington County by a Bidder or a prospective Bidder shall, upon receipt by Arlington County, become the property of the County.

4. BIDDER CERTIFICATION

Submission of a signed Bid Form is certification by the respective Bidder that it is registered with the Virginia State Corporation Commission, if applicable, it is the legal entity authorized to enter into an agreement with the County, and that it will accept any award made to it as a result of the submission.

5. ERRORS IN EXTENSION

Where the unit price and the extension price are at variance, the unit price will prevail.

6. EXCEPTIONS

Bidders taking exception to any part or section of this solicitation, including, by way of illustration and not limitation, the Contract Documents, Contract Terms and Conditions, General Conditions, Specifications, the Special Conditions, and any attachments or references thereto, shall indicate such exceptions on the Bid Forms. Failure to indicate any exceptions shall be interpreted as the Bidder's intent to fully comply with the solicitation as written. Conditional or qualified bids with such exceptions, unless specifically allowed in the solicitation, are subject to rejection in whole or in part as nonresponsive.

7. NON-CONFORMING TERMS AND CONDITIONS

If the Bidder submits with its bid alternate terms and conditions that do not conform to the terms and conditions in this solicitation, the bid will be subject to rejection for non-responsiveness. The County reserves the right to permit the Bidder to withdraw non-conforming terms and conditions from its bid prior to a determination by the County of non-responsiveness as a result of the submission of non-conforming terms and conditions.

8. EXPENSES INCURRED IN PREPARING BID

Arlington County accepts no responsibility for any expense incurred by any Bidder in the preparation and presentation of a bid. All expenses related to a bid are the sole responsibility of the Bidder.

9. BIDDER INVESTIGATIONS

Before submitting a bid, each Bidder must make all investigations and examinations necessary to ascertain all conditions and requirements affecting the full performance of the contract and to verify any representations made by the County that the Bidder will rely upon. No pleas of ignorance of such conditions and requirements resulting from failure to make such investigations and examinations will relieve the successful Bidder from its obligation to comply in every detail with all provisions and requirements of the contract documents or will be accepted as a basis for any claim whatsoever for any monetary consideration on the part of the successful Bidder.

10. SITE INVESTIGATION AND CONDITIONS AFFECTING THE WORK

Each Bidder acknowledges by submitting a bid that it has taken steps reasonably necessary to ascertain the nature and locations of the Work of the solicitation, and that it has investigated and satisfied itself as to the general and local conditions and factors which can affect the Work or its cost, including but not limited to:

- a. Conditions bearing upon transportation, disposal, handling, and storage of materials;
- b. The availability of labor, water, electric power, and roads;
- c. Uncertainties of weather, river stage, tides, or similar physical conditions at the site;
- d. The conformation and conditions of the ground; and
- e. The character of equipment and facilities needed before and during Work performance.

Each Bidder also acknowledges that it has satisfied itself as to the character, quality, and quantity of surface and subsurface materials or obstacles to be encountered insofar as this information is reasonably ascertainable from an inspection of the site, including all exploratory Work publicly or otherwise available, as well as from the drawings and specifications made a part of this solicitation.

Any failure of a Bidder to take the actions described and acknowledged in this paragraph will not relieve the Bidder from responsibility for estimating properly the difficulty and cost of successfully performing the Work without additional expense to the County.

The locations of existing utilities, including underground utilities, which may affect the Work are indicated on the drawings or in the specifications insofar as their existence and location were known at the time of preparation of the drawings. Nothing in these drawings or specifications shall be construed as a guarantee that such utilities are in the location indicated or that they actually exist, or that other utilities are not within the area of operations.

The Bidder shall make all necessary investigations to determine the existence and locations of such utilities. The Bidder will be held responsible for any damage to and maintenance and protection of existing utilities and structures, of both public and private ownership. If it is determined that such existing utility lines or structures require relocation or reconstruction or any other Work beyond normal protection or as called for in the Contract Documents, then such additional Work will be ordered under the terms of the clause entitled "Changes in Work".

The County assumes no responsibility for any conclusions or interpretations made by the Bidder based on the information made available by the County. The County assumes no responsibility for any understanding reached or representation made concerning conditions which can affect the Work by any of its officers or agents before the execution of the contract, unless that understanding or representation is expressly stated in the Contract.

11. INCOMPLETE DOCUMENTS

Each Bidder is responsible for having determined the accuracy and/or completeness of the solicitation documents upon which it relied in making its bid, and has an affirmative obligation to notify the Arlington County Purchasing Agent immediately upon discovery of an apparent or suspected inaccuracy, error in, or omission of any pages, drawings, sections, or addenda whose omission from the documents was apparent from a reference or page numbering or other indication in the solicitation documents.

If a potential Bidder downloaded an electronic version of the solicitation documents, that potential Bidder is responsible for determining the accuracy and/or completeness of the electronic documents.

If the successful Bidder proceeds with any activity that may be affected by an inaccuracy, error in, or omission in the solicitation documents of which it is aware but has not notified the Arlington County Purchasing Agent, the Bidder hereby agrees to perform any activity described in the missing or incomplete documents at Bidder's sole expense and at no additional cost to Arlington County.

12. ERRONEOUS OR OTHERWISE COMPROMISED REQUIREMENTS

Each Bidder is responsible for having determined the feasibility of the Work required, and shall notify the County Purchasing Agent immediately upon any discovery of any apparent erroneous, contradictory, incomplete, or infeasible requirements or directions contained in the Solicitation Documents. If a Bidder fails to notify the County of such conditions immediately upon discovery, the Bidder assumes all responsibility for any and all Work required to satisfy the contract requirements at no additional cost to the County and within the Contract Term.

13. QUALIFICATION OF BIDDERS

The Contractor shall have three (3) continuous years of on-call services construction contract experience conducting public works infrastructure and wet utilities improvement projects in an urban environment. The Contractor/Subcontractor shall also have three (3) years of continuous on-call services construction contract experience in regenerative stormwater conveyance (RSC), streambank stabilization and stream restoration construction including work in urban environment.

The experience shall be work of similar size and scope, construction and re-construction and shall include at least one (1) RSC project.

The Contractor obtained project experience shall consist of the following:

- **State and County streets**
- **Storm sewer pipes and inlets**
- **Water mains**
- **Sanitary sewer pipes and structures**
- **Curbs and gutters**
- **Sidewalks and walkways**
- **Driveway aprons**
- **Pavement markings and signage**
- **Streetscapes**
- **Erosion and sediment control in and adjacent to waterways**
- **Step pool and weir construction**
- **Longitudinal and cross-section channel surveys**
- **Stone stream BMP walls**
- **Bank, floodplain and channel grading**
- **Riffle and pool construction**
- **Bank stabilization, including biostabilization**
- **Riparian planting and restoration**
- **and related site work**

The Contractor shall provide a complete list of ten (10) projects completed within the last five (5) years with reference contact information for each project for Bidder qualification verification. Failure to

qualify according to the foregoing requirements will result in bid rejection by the Arlington County Purchasing Office.

14. DEBARMENT STATUS

The Bidder shall indicate in the space provided on the Bid Form whether or not it or any of its principals, is/are currently debarred from submitting bids to Arlington County, Virginia, or any other state or political subdivision, and whether or not it is an agent of any person or entity that is currently debarred from submitting bids to Arlington County, Virginia, or any other state or political subdivision. An affirmative response may be considered grounds for rejection of the bid.

15. ALTERNATE BID

Bidders who have other items they wish to offer in lieu of, or in addition to, what is required by this solicitation shall submit a separate bid clearly marked "ALTERNATE BID". Alternate bids will be automatically deemed nonresponsive and will not be considered for award. Such bids will, however, be examined prior to awarding the contract contemplated herein and may result in either cancellation of all bids in order to permit re-writing of the solicitation to include the alternate item in a rebid or the alternate item may be considered for future requirements.

16. INFORMALITIES

Arlington County reserves the right to waive minor defects or variations from the exact requirements of the solicitation in a bid insofar as those defects or variations do not affect the price, quality, quantity, or delivery schedule of the services being procured. If insufficient information is submitted for Arlington County to properly evaluate the bid by a Bidder; Arlington County reserves the right to require such additional information as it may deem necessary after the bid opening time and date, provided that the information requested does not change the price, quality, quantity, or delivery schedule for the services being procured.

17. USE OF BRAND NAMES/SUBSTITUTES

Unless identified as a "No Substitute" item in the solicitation, the name of a certain brand, make or manufacturer does not restrict Bidders to that specific brand, make or manufacturer. The use of the brand, make or manufacturer's identification is intended to convey the general type, style, character, and quality of the article described.

When a brand name is specified and followed by the phrase "or approved equal," the brand name product may be substituted if a suitable equivalent is accepted by the County Purchasing Agent. Any article which the County in its sole discretion determines to be the equivalent of the article specified, considering quality, workmanship, economy of operation, and suitability for the intended use, may be accepted and considered for award.

For those items not identified as "No Substitute", and followed by the phrase "or approved equal," the County has established the following procedure for determining the equivalency of a particular item:

Bidder Submission of Proposed Equivalent Item(s):

- 1) Bidder shall submit to the County its proposed item(s) for determination of their equivalency to the Brand Name(s) specified.

- 2) Each proposed item must be described on a separate page, indicating the appropriate specification section number, product or fabrication or installation method to be replaced, and specifics of the proposed item. Attach any technical information, photographs, brochures and the relevant data listed below that supports the proposed item and will permit the County to fairly determine acceptability of the item proposed:
 - a. Reasons why the specified product cannot be provided, if applicable.
 - b. Coordination information, including a list of changes or modifications needed to other parts of the Work that will be necessary to accommodate proposed substitution.
 - c. Detailed comparison of significant qualities of proposed substitution with those of the product specified.
 - d. Product Data, including drawings and descriptions of products and fabrication and installation procedures.
 - e. Samples, where applicable or requested.
 - f. List of similar installations for completed projects with project names and addresses and names and addresses of Architects and owners, if requested.
 - g. Material test reports from a qualified testing agency indicating and interpreting test results for compliance with requirements indicated.
 - h. Statement of impact on the construction schedule. If specified product or method of construction cannot be provided within the Contract Time, include letter from manufacturer, on manufacturer's letterhead, stating lack of availability or delays in delivery.
 - i. Cost information.
 - j. Contractor's certification that proposed substitution complies with requirements in the Contract Documents and is appropriate for applications indicated.
- 3) The County, in its analysis, will consider factors such as relative costs, equivalency of features, serviceability, the design of the item proposed, and/or pertinent performance factors as provided in the project technical specifications.
- 4) All pages of the submission shall be marked with the name, address and contact information of the Bidder, and sent to the Office of the Purchasing Agent to arrive prior to the question deadline established in Section I., paragraph I. ADDITIONAL INFORMATION. E-mail transmittals will be accepted at ischerbakov@arlingtonva.us.

County Review of Proposed Equivalent Item(s):

- 1) Approved item(s) will be added to the solicitation, in the form of an Addendum to the solicitation, and forwarded to all Bidders of record.
- 2) Bidders whose item(s) have not been approved will be so advised in writing simultaneously with the issuance of the Addendum.

18. NEW MATERIAL

Unless otherwise provided for in this solicitation, the Bidder represents and warrants that the goods, materials, supplies, or components offered to the County under this bid solicitation are new, not used or reconditioned, and are not of such age or so deteriorated as to impair their usefulness or safety and that the goods, materials, supplies, or components offered are current production models of the respective manufacturer. If the Bidder believes that furnishing used or reconditioned goods, materials, supplies or

components will be in the County's interest, the Bidder shall so notify the County Purchasing Agent in writing no later than fifteen (15) calendar days prior to the date set for opening of bids. The notice shall include the reasons for the request and any benefits which may accrue to the County if the Purchasing Agent authorizes the bidding of used or reconditioned goods, materials, supplies or components.

19. ARLINGTON COUNTY BUSINESS LICENSES

The successful Bidder must comply with the provisions of Chapter 11 ("Licenses") of the Arlington County Code, if applicable. For information on the provisions of that Chapter and its applicability to this solicitation, contact the Arlington County Business License Division, Office of the Commissioner of the Revenue, 2100 Clarendon Blvd., Suite 200, Arlington, Virginia, 22201, telephone number (703) 228-3060.

20. AUTHORITY TO TRANSACT BUSINESS

Any Bidder organized as a stock or nonstock corporation, limited liability company, business trust, or limited partnership or registered as a registered limited liability partnership shall be authorized to transact business in the Commonwealth of Virginia as a domestic or foreign business entity if so required by Title 13.1 or Title 50 of the Code of Virginia, or as otherwise required by law. The proper and full legal name of the firm or entity and the identification number issued to the Bidder by the Virginia State Corporation Commission must be written in the space provided on the Bid Form.

Any Bidder that is not required to be authorized to transact business in Virginia shall include in its bid a statement describing why the Bidder is not required to be so authorized. The County may require a firm to provide documentation prior to award which:

- (1) Clearly identifies the complete name and legal form of the firm or entity (i.e. corporation, limited partnership, etc.), and
- 2) establishes that the firm or entity is authorized by the State Corporation Commission to transact business in the Commonwealth of Virginia. Failure of a prospective and/or successful Bidder to provide such documentation shall be grounds for rejection of the bid or cancellation of the award. For further information, refer to the Commonwealth of Virginia State Corporation Commission website at: www.scc.virginia.gov.

21. VIRGINIA CONTRACTOR LICENSE

For all Work that is classified as being performed by "Contractors" as defined by the Virginia State Board for Contractors, a Class A, B, or C License is required. If a Bidder fails to obtain this license prior to submission of bid, the bid shall not be considered.

If a contract for performing or managing construction, removal, repair or improvements is for \$120,000 or more, or if the total value of all such construction, removal, repair, or improvements undertaken by the Bidder within any Twelve (12) month period is \$750,000 or more, the Bidder is required under Title 54.1, Chapter 11, Code of Virginia, as amended, to be licensed as a "CLASS A CONTRACTOR."

If a contract for performing or managing construction, removal, repair or improvements is for \$10,000 or more, but less than \$120,000, or if the total value of all such construction, removal, repair, or improvements undertaken by the Bidder within any Twelve (12) month period is \$150,000 or more, but less than \$750,000, the Bidder is required under Title 54.1, Chapter 11, Code of Virginia, as amended, to be licensed as a "CLASS B CONTRACTOR."

If a contract for performing construction, removal, repair or improvements is for \$1,000 or more, but no more than \$10,000 or if the total value of all such construction, removal, repair, or improvements

undertaken by the Bidder within any Twelve (12) month period is less than \$150,000, the Bidder is required under Title 54.1, Chapter 11, Code of Virginia, as amended, to be licensed as a "CLASS C CONTRACTOR." Class C contractors shall not include electrical, plumbing, and heating, ventilation and air conditioning contractors.

For further information, contact the State Board for Contractors, 2 South Ninth Street, Richmond, VA 23219, (804) 367-8511.

22. BID WITHDRAWAL PRIOR TO BID OPENING

No bid can be withdrawn after it is filed with the Bid Clerk unless the Bidder makes a request in writing to the Purchasing Agent prior to the time set for the opening of bids.

23. WITHDRAWAL OF BID FROM CONSIDERATION AFTER BID OPENING

After the opening of a bid, a Bidder may withdraw its bid from consideration if the price of the bid is substantially lower than other bids due solely to a mistake therein, provided the bid is submitted in good faith, the mistake is a clerical mistake as opposed to a judgment mistake, and is actually due to an unintentional arithmetic error or an unintentional omission of a quantity of work, labor or material made directly in the compilation of the bid, which unintentional error or unintentional omission can be clearly shown by objective evidence drawn from inspection of original Workpapers, documents and materials used in the preparation of the bid sought to be withdrawn. No partial withdrawals of bids will be permitted after the time and date set for the bid opening. The Bidder must give notice in writing to the Arlington County Purchasing Agent of a claim of right to withdraw a bid and provide all original Workpapers, documents and other materials used in the preparation of the bid sought to be withdrawn, within two (2) business days after the date of bid opening. A bid may also be withdrawn if the County fails to award or issue a notice of intent to award the bid within ninety (90) days after the date fixed for opening bids.

24. PARKING

At most County government facilities, parking for contractors' vehicles is not provided by the County. A contractor is responsible for the payment of any parking charges or fines resulting from illegal parking at any worksite(s).

25. TRADE SECRETS OR PROPRIETARY INFORMATION

Trade secrets or proprietary information that is submitted by a Bidder or contractor in connection with a procurement transaction or prequalification application submitted pursuant to subsection 4-101(2) of the Arlington County Purchasing Resolution may be exempted from public disclosure under the Virginia Freedom of Information Act ("VFOIA"). The Bidder or contractor must invoke the protection of this subsection prior to or upon submission of the data or other materials, and must identify clearly and in writing, on the Bid Form, the data or other materials sought to be protected and state the reasons why protection is necessary and falls within the exceptions to the VFOIA. It is the Bidder's sole responsibility to defend such exemptions if challenged in a court of competent jurisdiction.

26. INTEREST IN MORE THAN ONE BID AND COLLUSION

Multiple bids received in response to this solicitation from an individual, firm, partnership, corporation, affiliate, or association under the same or different names will be rejected. Reasonable grounds for believing that a Bidder is interested in more than one (1) bid for a solicitation both as a Bidder and as a subcontractor for another Bidder will result in rejection of all bids in which the Bidder is interested. However, a firm acting only as a subcontractor may be included as a subcontractor for two (2) or more

Bidders submitting a bid for the work. Any or all bids may be rejected if reasonable grounds exist for believing that collusion exists among any Bidders. Bidders rejected under the above provisions shall be disqualified if they respond to a re-solicitation for the same work.

27. METHOD OF AWARD

The County will make the award for this solicitation to the lowest responsive and responsible Bidder. The lowest Bidder will be determined by the Grand Total Bid price as listed on the Pricing Sheet.

28. INSURANCE REQUIREMENTS

Each Bidder must review the insurance requirements section carefully with its insurance agent or broker prior to submitting a bid to ensure they can provide the specific coverage requirements and limits applicable to this solicitation. If the Bidder is not able to meet the insurance requirements of the solicitation, alternate insurance coverage satisfactory to Arlington County may be proposed by the Bidder and considered by the County.

Written requests for consideration of alternate coverage must be received by the County Purchasing Agent, a minimum of Ten (10) working days prior to the date set for receipt of bids. If the County denies the request for alternate coverage, the coverage required by the Insurance Requirements Section must be provided.

If the County permits alternate coverage, an amendment to the Insurance Checklist will be issued prior to the time and date set for receipt of bids. The insurance requirements herein shall neither operate as a limitation of the Contractor's liability to the County nor as a limitation of the Contractor's duty of indemnification, as set forth in this solicitation and any resulting Contract.

29. SURETY REQUIRED

A. BID SURETY:

A fully completed and properly executed original Bid Bond, cashier's check, certified check, money order, or cash escrow in the amount of fifty thousand dollars (\$50,000) of the amount of the bid made payable to the Treasurer of Arlington County shall accompany each bid. The Bid Surety of all Bidders may be retained until after the award to the successful Bidder is made.

The Bid Surety of the successful Bidder shall be retained until completion of the Contract or the posting of a Performance Bond, whichever occurs sooner. A bid submitted without a bid surety, or with a bid surety in an amount less than the required amount, shall be rejected.

B. FAILURE TO EXECUTE:

The failure to accept an award and file acceptable Performance and Payment Bonds within Fifteen (15) days after notice of intent to award shall be just cause for cancellation of the award and the forfeiture of the Bid Surety to the County as liquidated damages. Award may then be made to the next lowest responsive and responsible Bidder.

C. PERFORMANCE SURETY:

A fully completed and properly executed original Performance Bond in the amount of one million dollars (\$1,000,000) will be required of the successful Bidder to ensure satisfactory completion of the work. The bond shall be a corporate surety bond issued by a surety company authorized to do business in the Commonwealth of Virginia and acceptable to the County.

Where applicable, the Performance Bond shall be renewable annually in the original amount through the completion of the Contract, including all warranty and guarantee periods.

D. PAYMENT BOND:

A fully completed and properly executed original Payment Bond in the amount of one million dollars (\$1,000,000), conditioned upon the payment of all persons who have and fulfill contracts for the Contractor for performing labor, providing equipment, or providing material in the performance of the Work provided for in the Contract, shall be required of the successful Bidder.

The Bond shall be a corporate surety bond issued by a surety company authorized to do business in the Commonwealth of Virginia and acceptable to the County. Where applicable, the Payment Bond shall be renewable annually in the original amount for the duration of the Contract Term.

30. OPTIONAL ESCROW AGREEMENT

If the successful Bidder so elects, the Bidder may utilize an escrow account for utilization of the retainage funds pursuant to § 2.2-4334 of the Code of Virginia. The Bidder must indicate on the Bid Form whether or not it elects the escrow account procedure.

31. EXECUTION OF AGREEMENT

Within fifteen (15) calendar days after the Agreement forms are presented by the County to the successful Bidder for signature, the Contractor shall deliver to the County Purchasing Agent Three (3) copies of the executed Agreement. Within the same Fifteen (15) day period, the Contractor shall deliver to the County Purchasing Agent executed Performance and Payment bonds, if such are required in the solicitation, and the required certificate of insurance.

The failure of the Contractor to execute the Agreement and to supply any required bonds and certificate, within the stipulated Fifteen (15) day period, or within such extended period as the County Purchasing Agent may grant, shall constitute a default, and the County may award the Contract to the next lowest responsive and responsible Bidder or solicit new bids. The County may then charge against the Contractor the difference between the amount of the Contract award and the amount for which a Contract is subsequently executed, up to the total amount of the Contractor's bid security.

32. NOTICE OF DECISION TO AWARD

When the County has made a decision to award a contract, an e-mail with a Notice of Decision to Award will be sent to all Bidders, using the e-mail address provided in the Bid Form.

II. ARLINGTON COUNTY DES ENGINEERING
SPECIAL CONDITIONS

TABLE OF CONTENTS

PROJECT SUMMARY	15
SUPPLEMENTS TO THE GENERAL CONDITIONS	16
ARTICLE B – DRAWINGS, SPECIFICATIONS AND RELATED DATA	16
SC-B.10 TESTS	16
SC-B.13 SURVEYS AND CONTROLS	16
ARTICLE C – COUNTY, COUNTY PROJECT OFFICER, AND CONTRACTOR RELATIONS	18
SC-C.1 STATUS OF COUNTY PROJECT OFFICER OR DESIGNEE	18
SC-C.4 INSPECTION OF WORK	18
SC-C.9 SUPERINTENDENCE BY CONTRACTOR	18
SC-C.11 LANDS BY COUNTY	19
SC-C.13 PROTECTION OF WORK AND PROPERTY	19
ARTICLE E – LEGAL RESPONSIBILITY AND PUBLIC SAFETY	19
SC-E.1 SITE INVESTIGATION AND CONDITIONS AFFECTING THE WORK	19
SC-E.2 PUBLIC CONVENIENCE	20
SC-E.10 SITE CLEAN-UP AND WASTE DISPOSAL	21
SC-E.11 STORMWATER POLLUTION PREVENTION PLAN (SWPPP)	21
ARTICLE G– MEASUREMENT AND PAYMENT	22
SC-G.1 PAYMENTS TO CONTRACTOR	22
ARTICLE F– PROGRESS AND COMPLETION OF THE WORK	23
SC-F.2 TIME FOR COMPLETION	23
SPECIAL CONDITIONS	24
1. CONSTRUCTION STANDARDS	24
2. PERMITS	25
3. SPECIAL CONTRACTOR/SUBCONTRACTOR QUALIFICATIONS	25
4. RFIs AND SUPPLEMENTAL INSTRUCTIONS	25
5. WEB-BASED RECORDS DOCUMENTATION	27
6. STAKEOUT AND CUT-SHEETS	27
7. SCHEDULE, DURATION, AND PHASING REQUIREMENTS	28

<u>8.</u>	<u>WORK HOURS</u>	28
<u>9.</u>	<u>GENERAL SITE SECURITY AND CONTROLS</u>	28
<u>10.</u>	<u>SPECIAL TRAFFIC MAINTENANCE CONSIDERATIONS</u>	29
<u>11.</u>	<u>REQUIREMENTS FOR WORK IN EXISTING ROADWAYS</u>	29
<u>12.</u>	<u>PAVEMENT RESTORATION FOR UTILITY CUTS</u>	29
<u>13.</u>	<u>PAVEMENT MARKING</u>	30
<u>14.</u>	<u>TRAFFIC SIGNALS AND STREETLIGHTS</u>	30
<u>15.</u>	<u>TEST PITS</u>	31
<u>16.</u>	<u>GENERAL EXCAVATION</u>	31
<u>17.</u>	<u>BYPASS PUMPING/TEMPORARY FLOW DIVERSION/DEWATERING</u>	32
<u>18.</u>	<u>TREE PROTECTION AND TRIMMING</u>	32
<u>19.</u>	<u>WORK ASSIGNMENTS</u>	32
<u>20.</u>	<u>MOBILIZATION AND RE-MOBILIZATION</u>	33
<u>21.</u>	<u>UNLISTED WORK</u>	34
<u>22.</u>	<u>JOB SIZE LIMITATION & ESTIMATED ACTIVITY</u>	34
<u>23.</u>	<u>OTHER COUNTY CONTRACTS</u>	34

PROJECT SUMMARY

The Contractor shall provide all resources to successfully perform the terms of this contract in accordance with project plans, and in compliance with Arlington County and VDOT Standards and Specifications. The Contractor shall perform the work complete, in place, tested, and ready for continuous service.

All work within the VDOT Right-Of-Way shall be performed in accordance with the VDOT Standards and Specifications, unless otherwise noted. All work within the County Right-Of-Way shall be in accordance with the Arlington County Standards and Specifications, unless otherwise noted.

The work performed under this contract will consist primarily of Capital Improvement Projects which involve improvements to existing infrastructure and associated outfalls and streams in Arlington County and VDOT Right-Of-Way. Projects will vary in size and shall not exceed \$500,000 per task order and the total expenditures for this contract are expected to be approximately \$1,000,000 to \$1,500,000 annually.

SUPPLEMENTS TO THE GENERAL CONDITIONS

These Conditions modify the Arlington County Construction General Conditions. All provisions that are not modified or deleted by these Supplemental Conditions shall remain in full force and effect.

The address system used in these Supplemental Conditions is the same as the address system used in the General Conditions, with the prefix "SC" added thereto.

ARTICLE B – DRAWINGS, SPECIFICATIONS AND RELATED DATA

SC-B.10 TESTS

Add the following new language to Paragraph B.10:

All materials testing shall be in compliance with the Arlington County Materials Testing Specification Reference Guide. This document specifies the method and frequency of testing for Arlington County projects. A copy of this document is included in the bid documents. This shall be incidental to the work and no separate payment will be made.

The Contractor shall engage the services of a geotechnical company, acceptable to both the County and VDOT, to conduct all materials testing per the County and VDOT Specifications.

If it is observed that samples for testing are being improperly taken or that samples are being taken from an area that is not fully representative of all project conditions, then Contractor shall take and test additional samples at the County Project Officer's request from areas designated by the County Project Officer and at the Contractor's expense.

In addition, the Contractor shall provide the County with unfettered site access as needed for VDOT/County personnel or VDOT/County consultants to enter the site, inspect, and perform any additional testing for any and all materials (including soil, concrete, asphalt, etc.).

Compaction results must meet VDOT Specifications and be certified by a Geotechnical Engineer licensed in Virginia. This work shall be at no cost to the County.

SC-B.13 SURVEYS AND CONTROLS

Delete Paragraph B.13 in its entirety and insert the following in its place:

Unless otherwise stated, the County will provide horizontal and vertical reference points necessary for the Contractor to proceed with the Work. The Contractor shall carefully preserve all reference points, and in the case of destruction thereof by the Contractor or due to the negligence of the Contractor or of any subcontractor, the Contractor shall be responsible for expense and damage resulting therefrom and shall be responsible for any mistakes or construction errors that may be caused by the loss or disturbance of such reference points. The Contractor shall be responsible for laying out the Work and shall

retain a professional land surveyor licensed in the Commonwealth of Virginia to survey and provide all necessary construction layouts and to establish all control lines, grades, and elevations during construction.

ARTICLE C – COUNTY, COUNTY PROJECT OFFICER, AND CONTRACTOR RELATIONS

SC-C.1 STATUS OF COUNTY PROJECT OFFICER OR DESIGNEE

Add the following new language to Paragraph C.1:

The County Project Officer will coordinate and consult with the VDOT Field Inspector as appropriate when working within the VDOT Right-Of-Way.

SC-C.4 INSPECTION OF WORK

Add the following new language to Paragraph C.4:

Contractor shall notify the Project Officer at least 3 working days prior to disturbing any existing, or installing any new, traffic signs, signals, or other traffic control devices. The Contractor shall allow 3 working days for the inspection and approval of the premarkings prior to placing the permanent markings.

SC-C.9 SUPERINTENDENCE BY CONTRACTOR

Add the following new language to Paragraph C.9:

Emergency Contact:

The Contractor shall have a qualified and experienced person who can clearly communicate technical matters regarding the subject project. This person shall be available via phone to respond to emergency situations on the project 24 hours a day.

Site Supervisor:

The Contractor shall have a qualified and experienced site supervisor who can clearly communicate technical matters on-site at all times when construction activity is occurring or when the site is not in a secure state.

Safety Project Officer:

For each task order, the Contractor shall have at least one (1) employee certified by VDOT in Advanced Work Zone Traffic Control on-site at all times that work is occurring and be responsible for the following:

- Placement, maintenance, and removal of work zone traffic control devices,
- Compliance with permit requirements and conditions, approved plans and specifications, the Virginia Work Area Protection Manual, and the Manual of Uniform Traffic Control Devices.

For each task order, the Contractor shall have at least one (1) employee certified in both OSHA 10 and OSHA 40 on-site at all times that work is occurring. The employee shall have served as a Project Safety Officer on at least three (3) prior projects. If the contractor has multiple employees with these requirements, the Contractor shall clearly identify which employee shall serve as the Project Safety Officer.

Environmental Project Officer:

For each task order, the Contractor shall have at least one (1) employee that has successfully completed the VDOT Erosion & Sediment Control Contractor Certification training. The contractor employee shall be on-site during all land disturbance activities. The Contractor shall be responsible for ensuring compliance with all applicable local, State, and Federal erosion and sediment control regulations and permits during land disturbance activities.

If the Contractor proposes to deviate from the approved Erosion and Sediment Control Plan, it shall be the Contractor's responsibility to coordinate and obtain approval from the County Project Officer prior to implementing any changes.

SC-C.11 LANDS BY COUNTY

Add the following new language at the end of C.11:

The Contractor shall confine all activities at the site associated with construction activities, to include storage of equipment and or materials, access to the work, formwork, etc. To within the designated Limits of Disturbance (LOD).

SC-C.13 PROTECTION OF WORK AND PROPERTY

Add the following new language to Subparagraph C.13.c:

The Contractor shall be responsible for all damages caused by their construction activities. The Contractor shall perform or provide repairs, replacements, and restoration to all property that has been damaged resulting from construction operations performed by the Contractor, and shall meet the following requirements:

1. Restore all areas to conditions that existed prior to construction. Remove and Replace damaged items with items equal to or better than the damaged items.

Add the following new language to C.13:

- g. The contractor shall contact "Miss Utility" at 811 for marking the locations of existing underground utilities (i.e. Water, sewer, gas, telephone, electric, and cable tv) at least 72 hours prior to any excavation or construction. The contractor is required to identify and protect all other utility lines found in the work site area belonging to other owners that are not members of "miss utility". Private water and/or sewer laterals will not be marked by "Miss Utility" or the County. The contractor shall locate and protect these services during construction.

ARTICLE E – LEGAL RESPONSIBILITY AND PUBLIC SAFETY

SC-E.1 SITE INVESTIGATION AND CONDITIONS AFFECTING THE WORK

Add the following new language at the end of E.1:

When construction activity reaches in proximity to existing utilities, the trench(es) shall be opened a sufficient distance ahead of the work or test pits shall be made to verify the exact location and inverts of the utility to allow for possible changes in the line or grade as directed by the Project Officer. This shall be incidental to the work and no separate payment shall be made.

SC-E.2 PUBLIC CONVENIENCE

Add the following new language to Paragraph E.2:

At the end of each work day, the road surface shall be brought flush with the existing asphalt using new asphalt on a daily basis and all lanes shall be open for traffic during non-work hours unless otherwise permitted in writing by the Project Officer. The contractor shall also maintain any temporary asphalt installed for the duration of the project to provide a smooth drivable surface with no significant potholes, dips, or bumps of any kind. Installation and maintenance of the temporary asphalt shall be considered incidental to the Contract and no additional payments shall be made for this work.

At all times the Contractor shall use the personnel and traffic control signs and devices necessary to comply with the Virginia Work Area Protection Manual and Part VI of the "National Manual on Uniform Traffic Control Devices." The Contractor has sole responsibility for ensuring that its operations are conducted in a safe manner and notwithstanding any other provision to the contrary, shall fully indemnify Arlington County, its officers, agents and employees for any damage or injury related to traffic operations which is caused by negligent or otherwise improper or deficient performance under the Contract or nonperformance of the terms of the Contract. All personnel, signs, barricades and any other items necessary for the maintenance of traffic and safety shall be provided by the Contractor.

When conditions warrant due to traffic volumes, patterns, or special events, the County may suspend or otherwise direct the Contractor's activities to protect the public and or the County's transportation network.

When the project includes a VDOT and/or County approved MOT Plan (or Plans), the Contractor shall strictly abide by this plan. If the Contractor proposes to deviate from the approved MOT Plan for a County road, it shall be the Contractor's responsibility to coordinate and obtain approval from the County Project Officer prior to implementing any changes. If the Contractor proposes to deviate from the approved MOT Plan for a VDOT road, it shall be the Contractor's responsibility to coordinate and obtain approval directly from VDOT prior to implementing any changes.

Prior to any lane closures within the VDOT Right-of-Way, the County Project Officer and VDOT Field Inspector must be notified in advance of such lane closure in accordance with VDOT requirements.

The Contractor shall not be entitled to any additional payment for changes to MOT which are the result of the Contractor's work schedule or resource allocation, weather delays, or other factors not controlled by the County.

Failure of the Contractor to correct any MOT deficiency immediately upon notification may result in the project being shut down until the deficiency is corrected, and a reduction from the amount of payment due in the amount of \$1,000.00 per violation. Repeated violations of this provision may result in contract termination.

The Contractor shall install project information signs (size - 36"x48") at least two (2) different locations for each site. Signs will be supplied by the County. Sign posts and incidentals necessary for a complete installation of the signs shall be furnished by the Contractor. Signs shall be installed at least two (2) weeks prior to the start of the construction. The Contractor shall coordinate the location of the signs with the Project Officer. After the project has been completed the Contractor shall remove and return the signs to the County Project Officer. The cost for this work shall be considered incidental to other items within the Contract and no separate payment will be made.

At the close of each work day, the area of work shall be confined to the smallest area possible, but in no event larger than the area designated in the Construction Documents, so that the maximum use of the street and sidewalk shall be restored and the hazard to traffic reduced to the minimum.

The Contractor shall preserve all bus stops, including maintaining adequate accessibility through and adjacent to the construction for buses and their passengers. The Contractor shall not close, relocate, or otherwise modify a bus stop without prior request of the Project Officer. Any relocation or closure of a bus stop will require at least four weeks advance notice for coordination with the county's bus stop coordinator.

SC-E.10 SITE CLEAN-UP AND WASTE DISPOSAL

Add the following new language to Paragraph E.10:

The County's Earth Products Recycling Yard (located at 4300 29th Street South, Arlington, VA) shall **not** be used on an as-needed basis for unspecified quantities of waste (due in part to the limited size of the Yard). Although atypical, the Yard **may** be considered, on a case-by-case basis, for disposal of specific types/quantities of waste from County construction projects. In such cases disposal arrangements must be approved by the County Project Officer, be made in advance, depend on available space and the type/quantity of waste, and comply with certain requirements (for example, concrete shall be broken into pieces no longer than 24" in any dimension, contain less than 20% soil content, and be free of rebar).

SC-E.11 STORMWATER POLLUTION PREVENTION PLAN (SWPPP)

Delete Paragraph 2.

ARTICLE G– MEASUREMENT AND PAYMENT

SC-G.1 PAYMENTS TO CONTRACTOR

Add the following new language to Paragraph G.1:

Payments will be based on actual quantities and site measurements of the approved work taken in the field by the County Project Officer using the Contract Unit Prices. Any Work that is not shown on the approved plans that has not been previously authorized in writing by the Project Officer shall be at the Contractor's expense, and at no cost to the County.

No additional payment for any incidentals will be made unless specifically requested through, and authorized by, the County Project Officer prior to the work. Such determination of additional payment will be at the sole discretion of the County Project Officer, and will be based upon the determination that there exist exceptional conditions which will necessitate significant expenditures of material and/or labor above and beyond the typical installation conditions which could be anticipated in Arlington County.

ARTICLE F– PROGRESS AND COMPLETION OF THE WORK

SC-F.2 TIME FOR COMPLETION

Delete Paragraph F.2 and replace with the following language:

It is hereby understood and mutually agreed by and between the Contractor and the County that the Commencement Date, the rate of progress, and the Time for Completion of the Work to be done hereunder are essential conditions of the Contract. The Contractor agrees that the Work shall be started promptly upon receipt of a written Notice to Proceed in accordance with the accepted schedule. The Works shall be prosecuted regularly, diligently, and uninterruptedly at a production rate of \$25,000 of installed value per week on projects where “normal daytime working hours” govern. For projects where “restricted work hours” in County and VDOT ROW govern, the Works shall be prosecuted regularly, diligently, and uninterruptedly at a production rate of \$17,000 of installed value per week. Additional time shall not be allowed for holidays or weather delays except as allowed in the contract.

SPECIAL CONDITIONS

These Special Conditions augment the General Conditions and include any project-specific requirements.

1. CONSTRUCTION STANDARDS

All work shall conform to project plans and specifications along with the current edition of following County, DEQ and VDOT construction standards, specifications and guides:

- **The Arlington County Department of Environmental Services (DES) Construction Standards and Specifications**, a copy of which may be downloaded at no charge from the internet at: <http://topics.arlingtonva.us/building/construction-standards-specifications/>
- **The Arlington County Department of Environmental Services (DES) Traffic Signal Specifications**, a copy of which may be downloaded at no charge from the internet at: <https://transportation.arlingtonva.us/traffic-signal-specification-updates/>
- **The Arlington County Department of Environmental Services (DES) Streetlight Specifications**, a copy of which may be downloaded at no charge from the internet at: <https://transportation.arlingtonva.us/streets/street-lights/lighting-standards-specifications-updates/>
- **The Arlington County Department of Environmental Services (DES) Pavement Marking Specifications**, a copy of which may be downloaded at no charge from the internet at: <http://transportation.arlingtonva.us/streets/traffic-signals/>
- **The Arlington County Department of Parks and Recreation (DPR) Specifications**, a copy of which may be downloaded at no charge from the internet at: <http://parks.arlingtonva.us/design-standards/>
- **The Virginia Department of Transportation (VDOT) Road and Bridge Standards and Specifications**, a copy of which may be downloaded at no charge from the internet at: http://www.virginiadot.org/business/locdes/Standards_TOC.asp and <http://www.virginiadot.org/business/const/spec-default.asp>
- **The Virginia Work Area Protection Manual (WAPM)**, a copy of which may be downloaded at no charge from the internet at: <http://www.virginiadot.org/business/trafficeng-WZS.asp>
- **Manual on Uniform Traffic Control Devices(MUTCD)**, a copy of which may be downloaded at no charge from the internet at: http://mutcd.fhwa.dot.gov/pdfs/2009r1r2/pdf_index.htm
- **The Arlington County Department of Environmental Services (DES) Dechlorination and Disposal Procedures**, a copy of which may be downloaded at no charge from the internet at: <http://topics.arlingtonva.us/building/discharging-chlorinated-water/>
- **The Virginia Stream Restoration & Stabilization Best Management Practices Guide**, a copy of which may be downloaded at no charge from the internet at: <https://www.deq.virginia.gov/Portals/0/DEQ/Water/Publications/BMPGuide.pdf>

- The supplementary specifications listed within the contract.

The Contractor shall have a copy of the aforementioned County and State Construction Standards, a copy of the project plans and specifications, and a copy of the appropriate permits available at the project site at all times when construction activity is occurring.

If there is any discrepancy between the project drawings/specifications and the County or State Construction Standards listed above, then the requirements of the project drawings/specifications shall prevail over the other documents.

2. PERMITS

Permits required for the project include, but are not limited to:

- **County Land Disturbing Activities (LDA) permit**
- **County Public Right-Of-Way (PROW) permit**
- **County Transportation Right-Of-Way(TROW) permits**
- **County Resource Protection Area (RPA) permit**
- **County Water Meter and Fire Hydrant permits**
- **VDOT Land Use permit**
- **VDOT Open Cut permit**
- **VA DEQ Virginia Storm Water Management Program (VSMP) permit**
- **USACE Nationwide General or Individual permit**
- **Northern Virginia Regional Park Authority (NVRPA) permit**

All fees for County permits will be waived by Arlington County, and fees for non-County permits will be paid by Arlington County.

The County will obtain the County LDA permit, the County RPA permit, VDOT Land Use permit, VDOT Open Cut permit, VSMP Permit, USACE permit and the NVRPA permits prior to the start of work. The Contractor shall transfer the County LDA permit, VDOT Land Use Permit, VDOT Open Cut permit and the VSMP Permit in the Contractors name as the permittee and/or responsible party prior to the start of Work. The Contractor shall complete and sign both the VDOT “LUP-E&S” and “LUP-WZTC” forms and submit to the County Project Officer for submission to VDOT two weeks prior to the start of Work within VDOT ROW.

The Contractor shall provide a Responsible Land Disturber (RLD) that meets all the required qualifications of the permits. The Contractor shall complete and sign the RLD certificate and submit to the County Project Officer prior to the start of Work.

The Contractor shall obtain the County PROW permit, the County TROW permits and the County Water Meter and Fire Hydrant permits. The Contractor is responsible for investigating and satisfying all permit requirements for the above-mentioned permits.

3. SPECIAL CONTRACTOR/SUBCONTRACTOR QUALIFICATIONS

The Contractor shall have **three (3) continuous years of on-call services construction contract experience conducting public works infrastructure and wet utilities improvement projects in an urban environment.**

The Contractor/Subcontractor shall also have three (3) years of continuous on-call services construction contract experience in regenerative stormwater conveyance (RSC), streambank stabilization and stream restoration construction including work in urban environment.

The experience shall be work of similar size and scope, construction and re-construction and shall include at least one (1) RSC project.

The Contractor obtained project experience shall consist of the following:

- **State and County streets**
- **Storm sewer pipes and inlets**
- **Water mains**
- **Sanitary sewer pipes and structures**
- **Curbs and gutters**
- **Sidewalks and walkways**
- **Driveway aprons**
- **Pavement markings and signage**
- **Streetscapes**
- **Erosion and sediment control in and adjacent to waterways**
- **Step pool and weir construction**
- **Longitudinal and cross-section channel surveys**
- **Stone stream BMP walls**
- **Bank, floodplain and channel grading**
- **Riffle and pool construction**
- **Bank stabilization, including biostabilization**
- **Riparian planting and restoration**
- **and related site work**

The Contractor shall provide a complete list of projects completed within the last five (5) years with reference contact information for each project for Bidder qualification verification. Failure to qualify according to the foregoing requirements will result in bid

rejection by the Arlington County Purchasing Office. The County will randomly contact at least five (5) of the references provided.

4. RFIs AND SUPPLEMENTAL INSTRUCTIONS

Request for Information (RFIs) shall be submitted in writing by the Contractor using a County RFI form (*sample attached for information only and which is subject to change at the County's discretion*), and transmitted via email to the County Project Officer. Only the Contractor, and not Subcontractors, shall submit RFIs.

RFIs shall only be used to request interpretation or clarification of apparent issues or problems found within the contract documents. The Contractor shall clearly identify and detail the issue, and provide its own interpretation within the RFI. Upon receipt of the RFI, the County shall respond to the Contractor via email within five (5) business days.

The following are not considered RFI's and may be rejected by the County if submitted as an RFI by the Contractor:

- **Routine project correspondence**
- **Material or shop drawing submittals**
- **Substitution requests**
- **Change orders**
- **Responses to non-conformance notices**
- **Similar project communications**

Responses to RFIs shall not be construed as authorization for a change order. The County may initiate a change to the contract by noting in the RFI response that a change order will be required. If the Contractor considers an RFI response to be a change to the contract, then the Contractor must notify the County Project Officer in writing immediately.

If changes occur after the individual project assignment is awarded that affect the project plans and specifications, and such change does not affect the contract schedule or cost, then a supplemental instruction may be issued by the County. Supplemental instructions are formal notifications to the Contractor providing additional instructions or to order minor project changes. These adjustments to the project plans and specifications may be the result of RFIs, value engineering, recognition of error/omission, changed conditions, requests for substitutions, etc.

5. WEB-BASED RECORDS DOCUMENTATION

Unless instructed otherwise, the Contractor shall use the web based construction management tool, e-Builder for, but not limited to, submittals, record keeping and document storage of all construction files including, invoices, pay applications, RFIs, approved shop drawings, change orders, construction progress meeting minutes, warranties, equipment specifications and brochures, record drawings, automated alerts and reminders for all functions, and Operation and Maintenance (O&M) Manuals.

6. STAKEOUT AND CUT-SHEETS AND AS-BUILTS

The Contractor shall be responsible for laying out the work and shall retain a professional land surveyor licensed in the Commonwealth of Virginia to provide all necessary construction layouts and establish all control lines, grades, and elevation during construction. The Contractor shall submit a copy of all cut-sheets for review, per the Arlington County Specifications. All cut-sheets for layout and construction shall be provided as submittals at least seven (7) calendar days prior to construction of the work included on that cut-sheet. The cost of all necessary surveying services shall be considered incidental to the work and no separate payment shall be made.

7. AS-BUILT SURVEY FOR STREAM RESTORATION AND STABILIZATION PROJECTS

The Contractor shall be responsible for as-built survey work for stream restoration and stabilization projects per Supplemental Specs Section 02025. The cost of all necessary surveying services shall be considered incidental to the work and no separate payment shall be made.

8. SCHEDULE, DURATION, AND PHASING REQUIREMENTS

The Contractor shall provide a schedule for all work listed on plans including any additional work not specifically mentioned on plans but was agreed upon with the County prior to work commencing.

Work Duration per task order shall be calculated in accordance with Supplements to the General Condition "SC-F.2 TIME FOR COMPLETION". The Time for completion shall be used as the basis for the project schedule.

Contractor shall make sure that the submittals/shop drawings are reviewed and accepted and materials ordered and delivered on site as no additional time will be granted for this.

9. WORK HOURS

The Contractor shall comply with **normal daytime working hours** as defined in the County Noise Control Ordinance unless otherwise defined by the project plans and specifications, or approved by the Project Officer.

The Contractor shall comply with **restricted working hours** of 9:00 am to 3:00 pm when working in Arlington County arterial streets unless otherwise indicated on the Maintenance of Traffic Plans for each project.

The Contractor shall comply with **restricted working hours** as defined by VDOT and as noted on the approved VDOT permit when working within the VDOT Right-Of-Way. For restricted work hours in VDOT ROW, see attached "Lane Closure Guidelines in NOVA District". The Contractor is responsible for satisfying all VDOT Permit requirements found at: <http://www.virginiadot.org/business/fairfax-permits-main.asp>.

In addition, the County reserves the right to restrict working days and hours to accommodate special site conditions as required.

10. GENERAL SITE SECURITY AND CONTROLS

The Contractor is responsible for securing its work area for safety and security. The Contractor shall confine its construction and presence to the Limits of Work, unless otherwise approved by the County Project Officer.

The Contractor shall provide, erect, and maintain barricades, fences, and/or signage as required to protect the general public, workers, and adjoining properties at no additional cost to the County. Before leaving the site at the end of each day, the Contractor shall replace any and all sections of the security fence or barricade moved or removed during work hours.

The Contractor shall maintain clear vehicular access to existing driveways and entrances at all times unless such access is otherwise addressed on County-approved project plans, precluding concrete pouring and curing of such access points, unless otherwise directed by the County Project Officer.

Homeowners shall be notified by the Contractor a minimum of fourteen (14) calendar days in advance of any driveway closure, and driveways can only be closed for a maximum of five (5) calendar days.

The Contractor shall monitor parking of construction personnel's private vehicles and ensure that the public has unobstructed access to and through parking areas.

11. SPECIAL TRAFFIC MAINTENANCE CONSIDERATIONS

Not Applicable

12. REQUIREMENTS FOR WORK IN EXISTING ROADWAYS

Existing manhole frames, covers, valve boxes and other appurtenances shall be adjusted to the final grade or replaced, as necessary. Unless otherwise specified, the cost for this shall be considered incidental to work, and shall be incorporated into the cost for relevant items. Connections to existing and proposed storm structures are considered incidental and no separate payment will be made.

Removal of concrete pavement, if encountered, will be to the next joint. In some cases, and when approved by the County Project Officer, the Contractor may be allowed to saw cut a neat joint mid-span of the existing concrete pavement. The limits of concrete pavement restoration shall be determined by the County Project Officer.

13. PAVEMENT RESTORATION FOR UTILITY CUTS

Pavement restoration for utility cuts in VDOT Right-Of-Way shall be in accordance with the detail shown in the LUP-OC NOVA Land Use Permit's Special provisions for pavement open cuts.

Pavement restoration for utility cuts in County Right-of-Way shall be in accordance with the Arlington County DES Standard Detail M-6.0 and M-6.1.

Temporary top asphalt installed to provide even grades with the existing roadway before the paving of the entire roadway shall be considered incidental and no payment shall be made by the County for furnishing materials and installation.

14. PAVEMENT MARKING

The Contractor shall have a certified VDOT Pavement Marking Technician present during pavement marking operations. Pavement markings shall be installed prior to opening the roadway to traffic as described in the Supplementary Specifications which includes requirements for temporary pavement markings.

Pavement markings disturbed by construction shall be restored immediately upon restoring pavement and shall be included in the pavement restoration price and shall not be paid as a separate item.

15. TRAFFIC SIGNALS AND STREETLIGHTS

Materials and construction of the communications conduit, streetlights, and traffic signals shall abide by the latest versions of the 'Arlington County Traffic Signal Specifications and Standards' and 'Arlington County Lighting Specifications and Standards. All materials for these areas shall be approved by Arlington County Transportation Engineering and Operations Bureau. The County Project Officer will facilitate the material specification submissions for review by the Transportation Engineering and Operations Bureau.

The Contractor shall abide by VDOT's requirement to submit signal foundation details for review. These details include, but are not limited to soil tests to verify the detail design, along with any other supporting information required by VDOT in their submission package. Details shall be created for each signal pole foundation and shall be for both three feet and four feet diameter foundations. The County will assist only in the submission of these details to VDOT, if requested. The Contractor is responsible for satisfying all VDOT requirements. The Contractor shall incorporate all costs for this in relevant items and no payment will be made by the County. The submission shall be submitted with enough time for VDOT to adequately review it. The Contractor cannot claim any time delay or any additional compensation due to such delay.

Prior to removal of the existing signal equipment and materials, the Contractor shall meet with the Project Officer to verify which equipment will be returned to the County, when and where the returned equipment will be delivered, and which equipment will be disposed. All costs associated with this shall be incidental to other items in the Contract.

As part of the luminaire installation, Contractor shall install house-side shields in each fixture. These shields will be provided by the County. If requested, the County will demonstrate how to install the shields. The Contractor shall contact Don Cunningham at (703) 228-6655 to obtain the shields prior to ordering any streetlight materials to ensure they will be available at the time of construction, and to request a demonstration on how to install the shields. Failure to do so will be at the Contractor's expense for time if construction is stopped because the shields are not available. The installation of the shields

is considered incidental to the contract and no additional payments shall be made for this work.

16. TEST PITS

The contract unit price for test pits (with restoration included within the unit price) shall apply only in the following cases, upon approval of the County Project Officer:

Utility conflicts shown on the plans provided to the Contractor for construction under this contract, but without test pit information provided by the County.

Utilities, which are not shown on the plans provided to the Contractor for construction under this contract, but are marked by the utility designator prior to construction.

Utilities, where depth verification is required and noted on the plan documents to be performed during construction, or directed by the Project Officer.

Protecting existing utilities is the Contractor's responsibility and any test pits performed to protect the existing utilities shall be incidental to the work and no separate payment shall be made for that purpose.

17. GENERAL EXCAVATION

All excavation shall be considered incidental to the work. No separate measurement and payment will be made for that purpose. It shall be considered a subsidiary obligation of the Contract under other work to which it relates.

During construction if the need arises for over-excavation, the Contractor shall request in writing the need for over-excavation. The Contractor must request approval from the County Project Officer prior to performing the work.

Excavation and shoring of any pits or shafts for trenchless or open trench methods of pipe installation, and any shoring left in place during installation shall be considered incidental to the installation of the pipe and shall be included in the unit price for installation of the pipe.

All sheeting, shoring, and bracing shall be in accordance with the current version of VDOT Specifications. Sheeting and shoring, if utilized may be abandoned in place up to five (5) feet below grade which shall be backfilled, etc. in accordance with the construction documents.

The maximum length of open trench shall be no more than one hundred (100) feet in roadways and three hundred (300) feet elsewhere unless written permission is obtained from the County Project Officer

No excavation shall remain open within the roadway or sidewalk without the approval of the County except when the excavation can be safely bridged with the use of steel plates or other materials acceptable to the County. When areas of excavation do remain open with the use of steel plates, warning signs shall be posted.

Steel plates may not be used within the VDOT Right-Of-Way from November 1st through April 1st. If steel plates are used during the allowable time period of April 2nd through October 31st, then their use shall comply with the most current VDOT Standards and Specifications.

18. BYPASS PUMPING/TEMPORARY FLOW DIVERSION/DEWATERING

The Contractor shall utilize temporary pumps to divert storm, and sanitary sewer flows during construction as required. All equipment used for these purposes shall comply with the requirements of the Arlington County Noise Ordinance. The Contractor shall be responsible for the installation, operation, and removal of the temporary pumps. The Contractor shall be responsible for utilizing pumps sufficient to bypass the normal flow and dewater the work area.

The Contractor shall furnish, install, operate and maintain all sumps, pumps, casings, wellpoints, dewatering device, portable dams/barriers and other equipment needed to perform the temporary flow diversion and dewatering of the construction site as needed for proper execution of the construction work.

The Contractor shall furnish to the County in writing, a plan for diverting flows and removal of water from the work area before beginning the construction work. Acceptance of this plan will not relieve the Contractor of responsibility for completing the work as specified

The cost for bypass pumping shall be incidental to other items in the Contract; therefore, there will be no separate payment for bypass pumping.

19. TREE PROTECTION AND TRIMMING

Minimizing damage to existing trees is very important. The critical root zone of existing trees is shown on the Construction Plans. Construction within the critical root zone of trees to remain requires root pruning to be performed as shown on the approved Plans in advance of the construction. If roots for trees not marked 'to be removed' on the Construction Plans are found during construction, the Contractor shall notify the Project Officer. The Project Officer shall consult with the Arlington County Urban Forester, then the Project Officer shall determine if additional root pruning is required. The additional root pruning performed by the Contractor shall be paid to the Contractor according to the unit price bid for root pruning.

Within all Tree Protection Zones and areas, the Contractor shall protect all existing trees in accordance with Arlington County Construction Standards and Specifications Section 02100 and the project documents: the area surrounding individual trees or groups of trees to be protected during construction, and defined by the drip line of individual trees or the perimeter drip line of groups of trees, or as defined by the County Project Officer, unless otherwise indicated on the project plans.

20. WORK ASSIGNMENTS

A **Proposal Request (PR)** will be sent by the County Project Officer to the Contractor along with project plans and documents. An acknowledgement from the Contractor shall occur within two (2) business days.

Within two (2) business days of the PR sent date, the Contractor may request and schedule pre-proposal meeting with the County.

Within five (5) business days of the PR sent date, the pre-proposal meeting shall be held with the County and Contractor.

Within fifteen (15) business days of the PR sent date, the Contractor shall confirm the County's project quantity or provide calculations for needed adjustments and submit a cost proposal to perform the work including a schedule with major milestones identified and meeting the time for completion specified in "SC-F.2 TIME FOR COMPLETION", the names of the Site Supervisor, Registered Land Disturber, Project Safety Officer, Project Environmental Officer and the Emergency Contact.

The County will review the submitted documents upon receipt, and either accept and issue a County-approved **Purchase Order (PO)**, or reject and issue a **Notice to Meet (NTM)**. These notices shall be sent via email correspondence to the Contractor. An acknowledgement from the Contractor shall occur within two (2) business days.

- Issuance of Purchase Order (PO)

With the issuance of the PO, the County Project Officer will schedule a pre-construction meeting with the Contractor, and (at County discretion) will schedule an on-site meeting with the Contractor. After these meetings, the County Project Officer will issue a **Notice to Proceed (NTP)** to the Contractor stating the Commencement Date (the date on which the contract time will commence) and on which the Contractor is to begin the prosecution of the work required under the contract. The NTP will specify the time of completion of the contract. The Contractor shall be expected to begin project assignments within five (5) business days from issuance of the NTP, unless a longer time is stipulated by the County Project Officer. Failure of the Contractor to meet response time requirements will be considered grounds for termination of the contract.

- Issuance of Notice to Meet (NTM)

With the issuance of the NTM, the County Project Officer will schedule a meeting with the Contractor within five (5) business days of issuing the NTM to resolve differences in quantities.

21. MOBILIZATION AND RE-MOBILIZATION

Mobilization

Payment for mobilization shall be based on bid form. The payment will be a multiplier (expressed as percentage maximum 5%) to be added to the total amount of project assignment cost. Payment for mobilization cost shall be made proportionally with payment

of each invoice. No additional payment for demobilization will be made. There will be no escalation for mobilization percentage multiplier for the initial contract term and the extensions thereafter.

Re-mobilization

If, due only to conditions created by the County or by unforeseen utility conflicts no work can be performed and the contractor is directed by the county project officer to cease work on an assigned project then the county will issue a 'Cease-Work Order'. Under these conditions the contractor shall be entitled to a re-mobilization fee upon resuming work on the project.

Payment for re-mobilization will be a multiplier of only the work not yet completed (expressed as a percentage maximum 5%) to be added to the cost of only the remaining work. The contractor shall not be entitled to any re-mobilization fees that are the result of the contractor's work schedule or resource allocation, weather delays, or other factors not controlled by the county.

Cost of re-mobilization shall be per the bid form for the remaining task order value at the time of remobilization. There will be no escalation for re-mobilization percentage multiplier for the for the initial contract term and the extensions thereafter.

22. UNLISTED WORK

The Bidder shall submit pricing for Unlisted Work that includes a schedule of equipment and labor hourly rates in the space provided on the Bid Form. Unlisted Work shall be determined in one or more of the following ways:

- Written estimate and acceptance by the County in a lump sum using the bid hourly rates,
- Cost-reimbursement using the bid hourly rates, or
- Other authorized method permitted under the Arlington County Purchasing Resolution.

23. JOB SIZE LIMITATION & ESTIMATED ACTIVITY

The size of the assigned jobs may vary throughout the contract term, but shall not exceed \$500,000 (Five hundred thousand dollars) per project assignment. Sample projects depicting type, scope, breath, and nature of work intended are provided as samples.

24. OTHER COUNTY CONTRACTS

Arlington County may solicit separate bids for work specified under this contract which may include items or services from other projects.

III. SUPPLEMENTAL SPECIFICATIONS

TABLE OF CONTENTS

COUNTY SPECIFICATIONS MODIFIED:

<u>SECTION NO.</u>	<u>DESCRIPTION</u>
01000	GENERAL PROVISIONS AND REQUIREMENTS
01300	SUBMITTALS
01500	TEMPORARY EROSION AND SEDIMENT CONTROL
02100	CLEARING AND GRUBBING
02200	EARTH WORK
02500	GRAVITY SEWERS AND APPURTENANCES
02515	TELEVISED INSPECTION OF SEWERS
02600	BITUMINOUS ROADWAY PAVEMENTS
02611	CONCRETE WALKS AND CONCRETE DRIVEWAY ENTRANCE
02750	CURB AND GUTTERS
02800	LANDSCAPING
02801	SEEDING AND SODDING

COUNTY SPECIFICATIONS ADDED:

<u>SECTION NO.</u>	<u>DESCRIPTION</u>
01550	MOBILIZATION
01720	PROJECT RECORD DOCUMENTS
02025	AS-BUILT SURVEY FOR STREAM RESTORATION AND STABILIZATION PROJECTS
02215	IMPORTED STREAM BED MATERIAL
02216	ON-SITE LARGE WOODY DEBRIS & LOG STRUCTURES
02218	ROCK STEP POOL STRUCTURES
02619	PERMANENT SIGNS
02802	LIVE STAKES
02900	PAVEMENT MARKINGS
13180	MAINTENANCE AND CONTROL OF TRAFFIC
311300	TREE PROTECTION AND ROOT PRUNING
329100	PLANTING PREPARATION
329200	SEEDING AND SODDING
329300	EXTERIOR PLANTS

This Section shall conform to the Arlington County Construction Standards and Specifications of Section 01000 except as modified herein.

Add the following to Section 01000:

19. Environmental Protection

The Contractor shall implement measures to prevent releases of pollution to the environment and unauthorized discharges to the County's storm drain system or surface waters. The Contractor shall ensure the pollution prevention measures outlined in Section 01500 Erosion and Sediment Control and Pollution Prevention are implemented throughout the duration of the work.

When the work includes an approved Storm Water Pollution Prevention Plan (SWPPP) required under Chapter 60 of the County Code (land disturbance of at least 2,500 square feet), the Contractor shall strictly abide by this plan which includes: a Pollution Prevention (P2) Plan, an Erosion and Sediment Control (ESC) Plan, and a Storm Water Management Plan. If the Contractor proposes to deviate from this approved plan, it shall be the Contractor's responsibility to coordinate and obtain approval from the County Project Officer prior to implementing any changes

This Section shall conform to the Arlington County Construction Standards and Specifications of Section 01300 except as modified herein.

Add the following to Section 01300, section 8. Shop Drawings:

- i. Contractor shall submit 6 (six) copies of all submittals/shop drawings.
- j. The Engineer will review the Shop Drawings within ten (10) Business Days.

Add the following to Section 01300:

11. Pavement Restoration Limit

Contractor shall submit the extent of the pavement restoration to the County for approval, prior to any saw cuts and/or milling and paving to the existing pavement.

SECTION 01500

TEMPORARY EROSION AND SEDIMENT CONTROL

This Section shall conform to the Arlington County Construction Standards and Specifications of Section 01500 except as modified herein:

Delete specification 01500 in its entirety and replace with:

PART 1- GENERAL

4.1 Description of Work

This work shall consist of implementation of erosion and sediment control and pollution prevention measures throughout the duration of the work to prevent unauthorized non-storm water discharges or pollution releases to the storm drain system or surface waters.

Where work is governed by an approved Storm Water Pollution Prevention Plan (SWPPP), the Erosion and Sediment Control and Pollution Prevention components of the SWPPP shall apply.

Erosion and sediment control measures shall include, but are not limited to, the use of berms, dikes, dams, sediment basins, fiber mats, silt fences, straw bales, washed gravel or crushed stone, mulch, grasses, slope drains, temporary seeding, and other methods. Erosion and sediment control measures shall be applied to erodible material exposed by any activity associated with the construction, and consistent with federal, state and local regulations.

All non-storm water discharges to the County's storm drain system, which includes the curb and gutter as well as the underground pipe network, or any open watercourse must comply with the conditions of the County's Virginia Storm Water Management Program, Municipal Separate Storm Sewer System (MS4) Permit. Examples of unauthorized non-storm water discharges include but are not limited to, wash water, slurry runoff from saw cutting, discharges associated with vehicle, equipment, and/or material washing, concrete wash water, process water, waste water, leaks from portable lavatories, equipment, vehicles and/or waste receptacles. Only clear, uncontaminated storm water discharges and/or permitted non-storm water discharges (as specified in a Virginia Pollutant Discharge Elimination System (VPDES permit)) are allowed to be discharged to the storm drain system or surface waters. Contaminants, including but not limited to, volatile organic compounds, petroleum products, metals, PCBs/Pesticides shall not be discharged to the County's storm sewer system.

4.2 Related Work Specified Elsewhere

Section 02100- Clearing and Grubbing

Section 02200- Earthwork

4.3 Applicable Regulations

Erosion and Sediment Control (Chapter 57 of the Arlington County Code)

Utilities (Chapter 26 of the Arlington County Code)

Storm Water Management (Chapter 60 of the Arlington County Code)

Chesapeake Bay Preservation Ordinance (Chapter 61 of the Arlington County Code)

Trees and Shrubs (Chapter 67 of the Arlington County Code)

Virginia State Water Control Board Regulations

4.4 Applicable References

Virginia Erosion and Sediment Control Handbook

Arlington County Storm Water Management Ordinance Guidance Manual
Arlington County Planning Guide to Erosion and Sediment Control
Arlington County Pre-Storm Erosion and Sediment Control Checklist
Arlington County Planning & Field Guide for Pollution Prevention (P2)
Arlington County Tree Protection and Planting Standards

4.5 Submittals

Prior to the start of any work that does not require a Land Disturbing Activity LDA and SWPPP, the Contractor shall prepare and submit a plan for implementing erosion and sediment control and pollution prevention measures. The plan shall include, but is not limited to, the operations of clearing and grubbing, stripping of topsoil, grading, stabilizing cleared areas, dewatering, spill prevention and cleanup, and the construction of structures at watercourses.

Any activity that disturbs greater than or equal to 2500 square feet requires a Storm Water Pollution Prevention Plan per the requirements of Arlington County Code Chapter 60. This plan contains the following elements:

- Erosion and Sediment (E&S) Control Plan
- Pollution Prevention Plan (P2 Plan)
- Storm Water Management Plan (SWMP)
- Virginia Storm Water Management Program (VSMP) Requirements where applicable

Construction work shall not commence until the schedule of work and the methods of operations have been reviewed and approved by the Engineer / Project Officer.

Erosion and sediment controls shall be coordinated with the construction of permanent storm water management facilities, drainage facilities and other contract work to the extent practicable to assure economical, effective, and continuous erosion and sediment control, and to prevent any damage, clogging, or other negative impacts upon the Work or other property.

Where work is governed by an approved SWPPP, the Contractor shall be responsible for all SWPPP self-inspection and documentation requirements.

Where work is governed by an approved SWPPP, the Contractor shall be responsible for all SWPPP self-inspection and documentation requirements which includes but is not limited to the following:

- A SWPPP box is installed and maintained at project site.
- Permit(s) and applicable documentation are posted near the SWPPP box.
- All sections of the SWPPP are kept complete and up to date throughout the duration of the project. (For example, notation of when erosion and sediment controls (ESC) are installed and information about the types of pollution prevention measures used.)
- Any modifications to controls are documented in the SWPPP, which includes the ESC plan.
- Self-inspections are conducted every four business days or as required.
- Completed and signed inspection reports are kept at the project site.
- Items identified during inspections requiring correction action are properly documented and addressed.
- The ESC Pre-storm checklist provided in the plan / SWPPP is used and followed accordingly.

4.6 Permits

The Contractor is responsible for complying with all applicable State, Federal, and Local permits which are required for construction, including, but not limited to:

- Virginia Water Protection Permits issued by the Virginia DEQ
- General Nationwide Permits issued by the US Army Corps of Engineers
- Land Disturbing Activity (LDA) permits (Virginia Stormwater Management Program (VSMP) authority permits) issued by Arlington County
- General Virginia Pollutant Discharge Elimination System (VPDES) Permit for Discharges of Storm Water from Construction Activity issued by Virginia DEQ.

A separate VPDES permit, issued by DEQ may be required for certain non-storm water discharges such as contaminated groundwater.

Unless otherwise specified as the responsibility of the Contractor in the ITB or contract documents, the County will obtain all applicable permits prior to awarding the contract. Permits will then be transferred to the Contractor.

PART 2 - MATERIALS

Materials shall be at the Contractor's option with the approval of the Engineer/Project Officer in accordance with Arlington County Code, Erosion and Sediment Control Ordinance (Chapter 57).

PART 3 - EXECUTION

3.1 Installation and Maintenance of Erosion and Sediment Controls

Where work is governed by an approved SWPPP, the contractor shall follow the plan and Erosion and Sediment Control Pre-Storm Checklist, which includes but is not limited to the conditions below. Where the work is not governed by an approved SWPPP, the contractor shall meet the conditions below as well as those specified in the Erosion and Sediment Control Pre-Storm Checklist.

- A. The Contractor, prior to starting work, shall properly protect storm drains to prevent pollutants, waste materials, sediment, or non-storm water discharges from entering the storm drain system. The Contractor shall implement and maintain controls as specified in the Virginia Erosion and Sediment Control Handbook and/or approved Storm Water Pollution Prevention Plan. Controls, practices, and/or devices must be monitored and maintained at all times to ensure proper operation condition.
- B. No grading operations will be allowed until erosion and sediment controls have been installed in accordance with the approved plan conforming to the requirements of Virginia Erosion and Sediment Control regulations and Arlington County Erosion and Sediment Control Ordinance.
- C. The Contractor shall keep stockpiled materials covered and perimeter controls shall be employed to minimize exposure to wind, precipitation, and runoff.
- D. The Contractor shall implement and maintain dewatering methods as specified in Arlington County Construction Standards and Specifications, VA Erosion and Sediment Control Handbook, Arlington County Planning & Field Guide to Erosion and Sediment Control, Arlington County Planning & Field Guide for Pollution Prevention (P2) and/or approved Storm Water Pollution

Prevention Plan. Controls, practices, and/or devices used for dewatering operations must be monitored and maintained at all times to ensure proper operation.

- E. The Contractor shall conduct dewatering operations in a manner to prevent sediment or other pollutants from discharging to the County's storm drain system, which includes the curb and gutter, or any surface water. Dewatering operations shall not create any erosion or flooding. Dewatering discharges that contain chemicals, hydrocarbons, or sewage shall not be discharged to the storm drain system. Any discharge from dewatering operations shall be properly filtered prior to being discharged. A dewatering plan with sufficient detail to ensure the proposed dewatering will comply with applicable regulations must be included as part of the erosion and sediment control plan.
- F. The Contractor is responsible for the installation and maintenance of any additional erosion and sediment control (ESC) measures necessary to prevent erosion and sedimentation as determined by the County, including but not limited to the actions listed in the County's Erosion and Sediment Control Pre-Storm Checklist (perimeter controls, slope stabilization, and covering stockpiles). Erosion and sediment controls shall be modified as needed to ensure clear water is discharged from the site. The County reserves the right to order the implementation of other erosion and sediment controls not specifically described herein to correct an erosion or pollution discharge condition.
- G. Control measures shall be properly maintained in accordance with state and local regulations. Immediately after every rainstorm, all control measures shall be inspected and any deficiencies corrected by the Contractor.
- H. Erosion and sediment controls shall be removed when the area has been stabilized and approval has been granted by the construction inspector.
- I. No further work will be allowed until erosion and sediment controls for the applicable phase have been installed in accordance with the approved plan conforming to the requirements of Virginia Erosion and Sediment Control regulations and Arlington County Erosion and Sediment Control Ordinance.

3.2 Pollution Prevention Measures

Where work is governed by an approved SWPPP, the contractor shall follow the plan, which includes but is not limited to the conditions below. Where the work is not governed by an approved SWPPP, the contractor shall meet the conditions below.

- A. The Contractor shall employ good housekeeping at work sites at all times. The Contractor shall collect, remove and legally dispose of all refuse, trash, litter, waste materials, and/or debris generated at the work site as frequently as necessary to prevent pollution releases from the site. Liquid waste must be properly contained prior to being placed into a waste receptacle to prevent leaking. The County, in its sole discretion, may require the Contractor to provide disposal tickets or other information sufficiently demonstrating legal disposal.

- B. The Contractor shall contain, capture, collect and legally dispose of any unauthorized non-storm water discharge(s), including but not limited to, saw cut slurry from saw cutting operations, concrete / asphalt wash water, waste water, and / or wash water from equipment, material, and/or vehicle washing.
- C. A vacuum system shall be used to collect liquid waste / slurry generated from saw cutting operations to prevent a discharge to a storm drain or surface water. Collected slurry must be disposed of at an approved waste receiving facility (e.g. landfill, soil safe, waste water treatment plant, commercial dump pad).
- D. Methods used for capturing / collecting unauthorized non-storm water discharges must be on site and operational prior to starting any work that will generate a non-storm water discharge.
- E. The Contractor shall have designated wash out areas or containers for materials, including but not limited to concrete, asphalt, paint, grout, mortar, stucco, form release oil, curing compounds, and /or sealers.
- F. Construction materials shall be properly stored and secured to ensure no pollutants are released into the environment.
- G. The Contractor shall ensure waste receptacles and portable lavatories are not damaged and/or leaking.
- H. The Contractor shall ensure spill clean-up materials (including but not limited to absorbent materials, spill pads, rags, booms, bags for waste disposal) and tools (including but not limited to shovels, brooms, containers, vacuums) are kept on the work site and accessible at all times. Spills and leaks shall be cleaned up as soon as discovered and wastes properly disposed of at an approved waste receiving facility. Spills shall not be washed into a street, storm drain, or surface waters.
- I. The Contractor shall ensure that the County's procedures for disposing of chlorinated water are followed (DES Construction Standards and Specifications, Section 02550 4.12 Discharge of Chlorinated Water).
- J. The Contractor shall not dump or dispose of anything in a storm drain, street, or stream that is not authorized under the County's VSMP MS4 permit or violates County Code Chapter 26-5 B and/or C.

3.3 Extent of Grading Operations

- A. The Contractor shall limit the surface area of earth material exposed by grubbing, stripping of topsoil and excavation to that which is necessary to perform the next operation within a given area.
- B. Unless specifically authorized by the Project Officer, the grubbing of root mat and stumps shall be confined to the area over which excavation is to be actively conducted within 30 days following the grubbing operations.

- C. The stripping of topsoil shall be confined to the area over which excavation is to be actively prosecuted within 15 days following the stripping operations; and excavation and embankment construction shall be confined to the minimum area necessary to accommodate the Contractor's equipment and work force engaged in the earth moving work.
- D. No disturbed area, including stockpiles, shall remain denuded longer than 7 days without temporary seeding or application of other stabilization practices approved by the Project Officer.

3.4 Tree Protection

- A. The Contractor shall ensure the specifications in the County's Tree Protection and Planting Standards are followed throughout the duration of the work.
- B. The Contractor shall protect all existing trees within a Tree Protection Zone.

PART 4 - MEASUREMENT AND PAYMENT

4.1 Measurement and Payment

- A. Temporary Erosion and Sediment Controls as detailed on the approved plan and as indicated in the bid line item shall be paid in lump sum unless otherwise specified.
- B. SWPPP administration as detailed under section 1.8 of this specification and as indicated in the bid line item shall be paid in lump sum.
- C. Unless otherwise specified, no separate payment shall be made by the County for maintenance of erosion and sediment controls or implementation of the pollution prevention measures specified on an approved plan, methods, or sequence of work; this work is considered to be a subsidiary obligation to the Contract.
- D. No separate payment shall be made by the County for erosion and sediment controls or pollution prevention measures required to correct conditions created due to the Contractor's negligence, carelessness or failure to install or properly maintain controls in accordance with approved plans.
- E. No separate payment shall be made by the County for changes to the plans which are the result of the Contractor's work schedule or resource allocation, weather delays, or other factors not controlled by the County.
- F. Unless otherwise specified, no separate payment shall be made by the County for implementation of spill clean-up, hauling fees, and/or collection, handling, transport and legal disposal of unauthorized non-storm water discharges (slurry, waste water, wash water) and/or other waste materials; this work is considered to be a subsidiary obligation to the Contract.

- G. In the event the Contractor repeatedly fails to satisfactorily control sediment and pollution releases, the County reserves the right to employ outside assistance or to use its own forces to provide the corrective measures indicated; the cost of such work, plus engineering costs, will be deducted from payments due to the Contractor for other work.

SECTION 02100

CLEARING AND GRUBBING

This Section shall conform to the Arlington County Construction Standards and Specifications of Section 02100 except as modified herein.

Add the following to Section 02100, PART 2 - MATERIALS:

This section left intentionally blank.

Add the following to Section 02100, PART 3 - EXECUTION:

11. Clearing

The area of clearing (limits of disturbance) shall be maintained within the limits shown on the plans. The Contractor shall ensure the specifications in the County's Tree Protection and Planting Standards are followed throughout the duration of the work. Trees and other vegetation that will not be removed shall be properly protected to avoid damage and limit adverse impacts. Protection devices around tree protection areas shall be installed and maintained throughout the duration of the work as directed by the Urban Forester (DPR). There shall be no disturbance inside the boundaries of the tree protection area. Equipment and materials may not be stored inside tree protection areas.

Add the following to Section 02100 PART 4 – Measurement and Payment

The removal of any designated tree small than 6" DBH shall be consider clearing and incidental to the WORK.

This Section shall conform to the Arlington County Construction Standards and Specifications of Section 02200 except as modified herein.

Add the following to Section 02200, PART 1 - GENERAL:

10. Saw Cutting

A vacuum system shall be used to collect liquid waste / slurry generated from saw cutting activities. Collected slurry must be hauled off and disposed of at a proper waste receiving facility (e.g. landfill, soil safe, waste water treatment plant, commercial dump pad).

Modify the following portions of Section 02200:

PART 3 - EXECUTION

18. Dewatering

At all times during construction the Contractor shall keep all excavations dry and promptly remove all water entering trenches and other excavations until the structures, pipes, and appurtenances to be built therein have been completed and backfilled. Dispose of all water pumped or drained from the work without impact to the Work, traffic, or injury to public or private property, and in compliance with all Local, State, and Federal regulations.

The Contractor shall implement and maintain dewatering methods as specified in Arlington County Construction Standards and Specifications, VA Erosion and Sediment Control Handbook, Arlington County Planning & Field Guide to Erosion and Sediment Control, Arlington Planning & Field Guide for Pollution Prevention (P2) and/or approved Stormwater Pollution Prevention Plan. Controls, practices, and/or devices used for dewatering operations must be monitored and maintained at all times to ensure proper operation condition.

The Contractor shall conduct dewatering operations in a manner to prevent sediment or other pollutants from discharging to the County’s storm drain system, which includes the curb and gutter, or any surface water. Dewatering operations shall not create any erosion or flooding. Dewatering discharges that contain chemicals, hydrocarbons, or sewage shall not be discharged to the storm drain system. A dewatering plan with sufficient detail to ensure the proposed dewatering will comply with applicable regulations must be included as part of the erosion and sediment control plan.

PART 4 - MEASUREMENT AND PAYMENT

25. Excavation

Delete: When explicitly **included** as a pay item, Excavation will be measured by the cubic yard as illustrated on the approved plans, or as approved by the Project Officer. Excavation in excess of that shown on the approved plans will not be compensated, unless specifically approved in advance by the Project Officer. Payment will include all labor, materials, and equipment and will include excavation, handling, storage and disposal of materials, backfilling, compaction, testing, and all other activities necessary to comply with these Specifications.

Add: All excavation and demolition shall be considered incidental to the work. No separate measurement and payment will be made for that purpose. It shall be considered a subsidiary obligation of the Contract under other work to which it relates.

26. Fill

Delete: When explicitly **included** as a pay item, Fill will be measured by the cubic yard in place as illustrated on the approved plans, or as approved by the project Officer, and will include all materials, equipment, and labor to construct the fills or embankments as illustrated on the construction drawings. Unless otherwise specified, Backfilling of excavations will not be compensated as Fill. Payment will include all clearing and grubbing, preparation, acquisition, transporting, storing, and handling of material, placement, shaping, compaction, and other activities necessary to comply with these Specifications.

Add: When explicitly **included** as a pay item on the Bid Form, Fill will be measured by the cubic yard in place as illustrated on the approved plans, or as approved by the project Officer, and will include all materials, equipment, and labor to construct the fills or embankments as illustrated on the construction drawings. Unless otherwise specified, Backfilling of excavations will not be compensated as Fill. Payment will include all clearing and grubbing, preparation, acquisition, transporting, storing, and handling of material, placement, shaping, compaction, and other activities necessary to comply with these Specifications.

27. Testing

Delete: Testing will be considered subsidiary to the Work and no compensation will be approved. If the Project Officer directs testing in excess of that required by the Contract Documents, the Contractor shall be entitled to compensation unless such testing reveals noncompliant work

Add: Materials testing shall be in compliance with County Specification Section 01400, and the Special Conditions of this Contract.

Add:

28. Saw Cutting

The cost for saw cutting shall be incidental to other items in the Contract; therefore, there will be no separate payment for saw cutting.

SECTION 02500

GRAVITY SEWERS AND APPURTENANCES

This Section shall conform to the Arlington County Construction Standards and Specifications of Section 02500 except as modified herein.

Add the following to Section 02500, PART 2 - MATERIALS:

Polypropylene Pipe (PPP)

1. PPP shall conform to ASTM F2881 and AASHTO M330
2. Joint performance shall meet or exceed ASTM D3212

Add the following to Section 02500, PART 3 – EXECUTION:

2. Laying Pipe

- D. PPP sewer shall not be installed with less than 2 feet of cover from the top of the pipe to finished grade
- E. PPP shall not be installed at depths greater than 20’ without special design analysis

3. Laying Pipe

- J. Install PPP in accordance with ASTM D2321

Modify the following portions of Section 02500:

PART 4 – MEASUREMENT AND PAYMENT

4.2 Manholes

Delete in its entirety and replace with the following:

Manholes for the various internal diameters shall be measured **by each** up to 8 vertical feet from the top of the manhole cover thereafter the measurement shall be in vertical feet to the invert of the outlet pipe. Payment shall include excavation, backfill, bedding, foundation, base and components, channels, sleeves, frame and cover, intermediate landings, steps, restoration and all other work necessary for a complete installation.

Add the following after subsection 4.4 Excavation Below Grade and Additional Bedding:

4.5 PVC Pipe with Perforated PVC Pipe

PVC pipe with Perforated PVC Pipe for the various materials, classes, and sizes shown on the plans shall be measured in linear feet along the center line of the pipe and shall be measured from inside wall of structure to inside wall of structures. Payment shall include the furnishing of all pipe and fittings, valve box with cap, all necessary tests, excavation, removal and disposal of existing pipes, removal and disposal of unsuitable or surplus material, placement of bedding and backfill as shown in Standard M-3.0, restoration, core drilling, #57 gravel, filter fabric, top soil, sod, and all work incidental to providing a complete PVC pipe with Perforated PVC pipe sewer installation.

4.6 PVC Cleanout

PVC Cleanout for the various materials, classes, and sizes shown on the plans shall be measured as each. Payment shall include the furnishing of all pipe and fittings, valve box with cap, all necessary tests, excavation, removal and disposal of existing pipes, removal and disposal of unsuitable or surplus material, placement of bedding and backfill as shown in Standard M-3.0, restoration, #57 gravel, filter fabric, and all work incidental to providing a complete PVC Cleanout installation.

4.7 Sump Pump Core and Cleanout Connection

Sump Pump Core and Cleanout Connection for the various materials, classes, and sizes shown on the plans shall be measured as each. Payment shall include the furnishing of all pipe and fittings, valve box with cap, all necessary tests, excavation, removal and disposal of existing pipes, removal and disposal of unsuitable or surplus material, placement of bedding and backfill as shown in Standard M-3.0, restoration, radial core drilling, #57 gravel, filter fabric, top soil, sod, proposed connections to storm structures and storm pipes, and all other work incidental to providing a complete Sump Pump Core and Cleanout Connection installation.

SECTION 02515

TELEVISED INSPECTION OF SEWERS

This Section shall conform to the Arlington County Construction Standards and Specifications of Section 02515 except as modified herein.

Add the following to Section 02515:

PART 3 – EXECUTION

Add the following at the end of subsection 3.2. Documentation

- E. The Contractor shall report any evidence of illicit discharges or illicit connections to the storm drain system to the Department of Environmental Services.

SECTION 02600

BITUMINOUS ROADWAY PAVEMENTS

This Section shall conform to the Arlington County Construction Standards and Specifications of Section 02600 except as modified herein.

Modify the following portions of Section 02600:

4.7 Base Course

Delete: The base course shall be bituminous concrete consisting of course and fine aggregate combined with asphalt cement, resulting in a mixture of Type BM-2 in conformance with Section 211 of the VDOT Specifications.

Add: The base course shall be bituminous concrete consisting of course and fine aggregate combined with asphalt cement, resulting in a mixture of Type BM-25.0A in conformance with Section 211 of the VDOT Specifications.

4.8 Surface Course

Delete: The surface course shall be bituminous concrete consisting of crushed stone, crushed slag, or crushed gravel and the fine aggregate, slag or stone screenings, or combination thereof, combined with asphalt, cement, resulting in a mixture of Type SM-2A in conformance with Section 211 of VDOT Specifications.

Add: The surface course shall be bituminous concrete consisting of crushed stone, crushed slag, or crushed gravel and the fine aggregate, slag or stone screenings, or combination thereof, combined with asphalt, cement, resulting in a mixture of Type SM-9.5A in conformance with Section 211 of VDOT Specifications.

4.5 Traffic Marking

Delete: Traffic marking will be provided by the County.

Add: Traffic marking will be provided by the Contractor.

Add the following to Section 02600, PART 4 – MEASUREMENT AND PAYMENT:

4.3 Excavation and demolition is incidental to the work and no separate payment shall be made for that purpose

SECTION 02611 CONCRETE WALKS AND CONCRETE DRIVEWAY ENTRANCE

This Section shall conform to the Arlington County Construction Standards and Specifications of Section 02611 except as modified herein.

Modify the following to Section 02611, PART 4 – MEASUREMENT AND PAYMENT:

4.4.

Delete: Excavation shall be measured in cubic yards in its original condition based on the but sheets and typical sections. Payment shall be in cubic yards as described in Section 02201

Add: Excavation and demolition shall be considered incidental to the work and no separate payment shall be made for that purpose.

SECTION 02750

CURB AND GUTTERS

This Section shall conform to the Arlington County Construction Standards and Specifications of Section 02750 except as modified herein.

Add the following to Section 02750, PART 4 – MEASUREMENT AND PAYMENT:

- 4.3 Excavation and demolition is incidental to the work and no separate payment shall be made for that purpose

Delete SECTION 02800 in its entirety.

Delete SECTION 02801 in its entirety.

COUNTY SPECIFICATIONS ADDED:

SECTION 01550

MOBILIZATION

PART 1 - GENERAL

This work shall consist of performing preparatory operations, including moving personnel and equipment to the project site; paying bonds and insurance premiums; and establishing field offices and other facilities necessary to allow work to begin on a substantial phase of the Contract.

PART 4 - MEASUREMENT AND PAYMENT

Payment for mobilization shall be based on bid form. The payment will be a multiplier (expressed as percentage) to be added to the total amount of project assignment cost. This price shall also include demobilization. There will be no escalation for mobilization percentage multiplier for the initial contract term and the extensions thereafter

Payment for mobilization for each site will be made in two equal installments. The first installment of 50% of the unit price for mobilization will be made on the first progress estimate following partial mobilization and initiation of construction work. The second installment will be made on the next progress estimate following completion of substantial mobilization, including erection of field offices.

No additional payment will be made for demobilization and remobilization because of shutdowns, suspensions of work, or other mobilization activities.

In case of Change Order outside the project area, mobilization shall be included in the price for other appropriate items.

In case of Change Order within the project area, mobilization shall be considered as incidental and included in the unit bid price for mobilization. There will be no separate measurement and payment will be made for this work.

PART 1 - GENERAL

1.1 Purpose of Section

This section outlines the requirements for keeping record drawings (As-Built Drawings) and other data in accordance with the General Conditions and in accordance with the following specifications.

1.2 Record Drawings

- A. The Contractor shall maintain one complete set of drawings specifically for the purpose of recording changes during the construction of the project. During the course of construction, the Record Drawings shall be updated daily by the end of each working day.
- B. Record Drawings will be neat, accurate and complete. The Record Drawings will be available for periodic inspection by the Engineer.
- C. Record Drawings shall include the following, as a minimum:
 - 1. Details not shown on original Contract Drawings.
 - 2. Actual locations (horizontal and vertical) of all utilities uncovered during the course of the work.
 - 3. Any changes in grade and location of duct banks and appurtenances.
 - 4. Any changes, additions or deletions made by Change order or Addenda.
 - 5. Final coordinates of all structures built or modified under this Contract.
- D. The Contractor shall certify the Record Drawings as accurate and complete.

1.3 Submission Requirement

The Contractor shall submit the Record Drawings (both in digital format and 2 full size hardcopy sets) to the Project Officer upon substantial completion of the Project. Final payment will not be issued until the Record Drawing has been accepted by the Project Officer. The Contractor shall make any necessary corrections and resubmit until acceptable to the County Project Officer.

PART 4 - MEASUREMENT AND PAYMENT

Project Record Documents are considered a subsidiary obligation of the contract, and therefore no payment will be made for this work.

SECTION 02025 AS-BUILT SURVEY FOR STREAM RESTORATION AND STABILIZATION PROJECTS

This Section is an addendum to the Arlington County Department of Environmental Services Construction Standards and Specifications for this Contract.

PART 1 – GENERAL

The Contractor shall prepare and submit to the Engineer a certified As-Built Survey that fully illustrates all construction completed within the Limits of Disturbance. The As-built Survey must be submitted to the Engineer after grading is completed and not later than 30 days after the project is accepted. An electronic CAD file must accompany the hard copy submittal bearing the PLS seal. Electronic files must be in AutoCAD (release 2013 or later).

PART 2 – MATERIALS

PART 3 – EXECUTION

3.1 The As-built Survey is required within the Limits of Disturbance of this project and must include the following surveyed features:

- A. Plan View of the project area that should include the following information:
 - 1. Limits of grading;
 - 2. Alignment based on stream thalweg;
 - 3. Left and right top of bank;
 - 4. Left and right toe of bank;
 - 5. Key floodplain break points (e.g., top and toe of terraces, benches and berms);
 - 6. Revised boundaries for wetland areas as located by the Engineer;
 - 7. Boundaries of surface water features (e.g. vernal pools, ponds, stormwater BMPs);
 - 8. Elevation contour lines at one-foot increments within the grading limits;
 - 9. Location of utility lines within the disturbance areas verified prior to construction;
 - 10. Inverts of all proposed Storm and Sanitary pipes as well as structure tops;
 - 11. Surveyed benchmarks (e.g. permanent, TBM, property boundaries);
 - 12. Top and bottom of walls (such as stacked stone stream BMP or retaining walls).
 - 13. Elevations of points on in-stream structures at locations shown on the structure table in the construction documents.
 - 14. Other features flagged by the consultant construction manager; and
 - 15. Limits of floodplain berm removal areas.

- B. The cross-section locations required to be surveyed shall be marked by the Engineer in the field and on the working plans. The contractor shall establish and monument permanent cross sections with control points surveyed for horizontal and vertical datum. The total number of cross-sections required shall be four consisting of two riffle

and two pool cross sections. The record drawings shall include the following cross-section information:

1. Plot of the cross sections including station overlaid on typical cross sections; and
 2. Plot of the cross sections including channel, relevant floodplain, and flood prone area. Relevant floodplain shall include all floodplain benches and existing floodplain within the flood prone area. The Engineer shall incorporate the As-built Survey layer into the design plan sheets and mark-up all changes that took place in the field so that the completed as-built plans can accurately show design conditions and field changes.
- C. The longitudinal profile survey shall be conducted upon the entire length of channel constructed within the Limits of Disturbance. Survey points shall be collected at the head of each bed feature and the head and tail of each grade control structure. The record drawings shall include the following information on the longitudinal survey:
1. Plot of the entire as-built thalweg with notes on deviation from the design thalweg, overlaid on the design thalweg;
 2. Plot of the entire as-built water surface;
 3. Plot of the entire as-built top of bank (TOB), overlaid on the design TOB; and
 4. Plot of the entire as-built bankfull elevation, overlaid on the design bankfull elevation.

PART 4 – MEASUREMENT AND PAYMENT

As-Built Survey will be measured and paid for as a lump sum price. Such price and payment will be full compensation for all work covered by this section.

Pay Item	Pay Unit
As-built Survey	Lump Sum (LS)

This Section is an addendum to the Arlington County Department of Environmental Services Construction Standards and Specifications for this Contract.

PART 1 GENERAL**1.1 DESCRIPTION OF WORK**

This item consists of obtaining cobble-gravel-sand material from an approved off-site source and installing it as Bedding along the proposed streambed. Salvage material from the existing streambed may be used to supplement imported materials provided its gradation is consistent with this specification.

This work consists of constructing the Imported Stream Bed Material with imported stone in the sections of channel as indicated on the plans once channel excavation is complete.

The quantity of material to be installed will be affected by the actual conditions that occur during the construction of the project. The quantity of structures may be increased, decreased, or eliminated entirely as directed. Such variations in quantity will not be considered as alterations in the details of construction or a change in the character of the work.

1.2 SUBMITTALS

Stone Source and Properties, CA

The Contractor shall obtain a written statement from the supplier certifying that the stream bed material to be furnished and delivered to the construction site meets the requirements for gradation and source as stipulated on the Construction Drawings.

The source or sources of proposed import Bedding material shall be indicated to the Engineer a minimum of ten (10) working days prior to delivery to the construction site. The Contractor and Engineer will visit the source(s) concurrently to ensure that the proposed Bedding material meets the specification requirements.

PART 2 MATERIALS**2.1 NATURE AND GRADATION OF BEDDING MATERIALS**

Size distribution for the imported bedding material will vary according to the project site and specifications for each project will be included on the Construction Drawings. For each project the bedding material shall meet the size distribution specified on the construction drawings. For estimating purposes, a recent County stream project used bedding material with the following size distribution:

	Min (mm)	Max (mm)	Min (inches)	Max (inches)
D16	0.04	0.08	0.002	0.003
D35	30	60	1.2	2.4
D50	130	190	5.1	7.5
D65	240	310	9.4	12.2
D84	380	440	15.0	17.3
D95	460	520	18.1	20.5

The Cobble-Gravel void ratio for this mix was estimated at 20%. Therefore, 20% by volume of CL material was added to the imported Cobble-Gravel-Sand material prior to placement.

See below for details relative to mixing, placing, and compacting stream bed material.

PART 3 EXECUTION

3.1 PLACEMENT OF BEDDING MATERIAL

Imported Stream Bed Material shall be constructed according to the details shown on the plans, or as directed by the Engineer in the field.

1. Excavate the stream bed.
2. No bedding shall be placed until foundation preparation is completed and the foundation and excavations have been inspected and approved by the Engineer.
3. The cobble/gravel/sand mixture shall be placed and spread uniformly and neatly in one horizontal layer on the prepared sub-grade surfaces to the depth indicated in the typical detail.
4. The bedding layer shall be compacted by at least 4 passes, over the entire surface, of the track of a crawler-type tractor weighing not less than 8 tons or an equivalent method approved by the Engineer.

PART 4 MEASUREMENT AND PAYMENT

Imported Stream Bed Material will be measured and paid for to the nearest cubic yard complete and in place. Such payment will constitute full compensation for all materials, labor, equipment, tools and all other items necessary and incidental to performance of the work.

Pay Item

Stream Bed Material

Pay Unit

Cubic Yard (CY)

This Section is an addendum to the Arlington County Department of Environmental Services Construction Standards and Specifications for this Contract.

The following log structure specifications are incorporated by reference:

- A. Log Vanes – Virginia Stream Restoration & Stabilization Best Management Practices Guide, Practice 4.4. Log Vanes
- B. Log Drops - Virginia Stream Restoration & Stabilization Best Management Practices Guide, Practice 3.5. Log Drops

Where these special provisions conflict with or modify the above specifications, these provisions shall govern.

PART 1 – GENERAL

1.1 Description of work:

Work consists of installing on-site large woody debris and log structures, including log vanes and log drops, within the project area, as specified in the Contract Documents.

1.2 Applicable specifications:

- A. Log Vanes – Virginia Stream Restoration & Stabilization Best Management Practices Guide, Practice 4.4. Log Vanes
- B. Log Drops - Virginia Stream Restoration & Stabilization Best Management Practices Guide, Practice 3.5. Log Drops

PART 2 – MATERIALS

2.1 On-site Large Woody Debris

On-site large woody debris installation shall consist of any downed trees or woody debris within the limits of disturbance (LOD) to be used as a large woody debris habitat structure. On-site woody debris to be used for this construction shall be salvaged from the project site provided that they meet the above requirements, are within the limits of grading, and are clearly flagged for removal. Only live trees identified for removal shall be harvested for the sole purpose of providing materials for this item.

2.2 Log Structures

Use sound hardwood trees that do not have heart rot, and are not cracked or split. Trunks will have a minimum diameter of 12 inch and have all branches removed (dressed). Trees with root mass attached will have a minimum total length of 15 feet. Trees felled on-site should be considered the primary source for in-stream structures, ahead of trees obtained from debris dams. All trees used for structures must be authorized by the Project Officer prior to placement.

PART 3 – EXECUTION

3.1 On-site Large Woody Debris

1. Carefully transport on-site large woody debris to minimize breakage of limbs.
2. Locate on-site large woody debris in shallow aquatic pools at locations shown on Construction Documents or as determined in the field by the Engineer.
3. Partially bury on-site large woody debris into the streambank to secure it in place. Placement of the on-site large woody debris shall be verified by the Engineer to ensure that it is secure.

3.2 Log Structures

Refer to Log Vanes (Practice 4.4) and Log Drops (Practice 3.5) specifications in the Virginia Stream Restoration & Stabilization Best Management Practices Guide.

PART 4 – MEASUREMENT AND PAYMENT

On-site woody debris will be measured and paid for as a unit price per item. Log vanes and log drops will be measured and paid for as a unit price per structure. Such payment shall be considered full compensation for each item or structure, including the cost for storing and furnishing all materials, labor, equipment, incidentals, site preparation, installation and clean-up associated with each item or structure.

Pay Item	Pay Unit
Log Vane	Each (EA)
Log Drop (per Detail 3.5a)	Each (EA)
Log Drop (per Detail 3.5b)	Each (EA)
Large Woody Debris	Each (EA)

This Section is an addendum to the Arlington County Department of Environmental Services Construction Standards and Specifications for this Contract. The Virginia Stream Restoration and Stabilization Best Management Practices Guide specification for Rock Cross Vanes is incorporated by reference. Where these special provisions or the Construction Drawings modify or conflict with the reference specification, these special provisions and the Construction Drawings shall govern.

PART 1 GENERAL**1.1 DESCRIPTION OF WORK**

This work consists of constructing Rock Step Pool Structures. Rock Step Pool Structures are in-stream flow structures primarily used for grade control, reducing near bank shear stresses, and providing habitat at locations designated on the plans to diversify the low flow path. The rock structures extend across the entire streambed and tie into both banks. Pools are excavated below the rock structures, and the streambed upstream and downstream of the rocks are lined with imported riffle bed material.

1.2 SUBMITTALS

Rock Boulder Source and Properties

Laboratory Test Data verifying quality of proposed Rock Boulders

The Contractor shall locate potential sources of natural Rock Boulders that conform to all contract requirements. The source or sources of proposed Rock Boulder material shall be indicated to the Engineer a minimum of ten (10) working days prior to delivery to the construction site. The Contractor and Project Officer will jointly visit the identified sources to determine whether the Rock meets the size, shape and color requirements specified. The Contractor will not be granted an extension of time due to delay caused by sampling, testing, approval or disapproval of Rock Boulder material in complying with contract requirements. The Contractor shall submit a signed certification from the supplier stating that each load of rock delivered to the site meets the requirements of this specification.

Existing Rock Boulders within the stream corridor shall be used as appropriate and approved by the Project Officer for constructing boulder structures and/or features as described under Section 1.1 above.

1.3 REFERENCE SPECIFICATIONS

Virginia Stream Restoration & Stabilization Best Management Guide Practice 3.1 Rock Cross Vanes (Details 3.1a & b)

PART 2 MATERIALS**2.2 ROCK QUALITY**

Individual Rock Boulder shall be block-like in shape and meet the minimum/maximum size requirements specified on the Construction Drawings. Rock Boulder color shall blend with the existing streambed material. Green/Gray, brown/gray, dark gray, and/or dark brown shall be acceptable. White Rock is not acceptable. All Rock shall be free from laminations, weak cleavages and will not disintegrate from the

action of air, water and in handling and placing. Granular sedimentary stone will generally be unacceptable.

Rock Boulders shall have a minimum Bulk Specific Gravity of 2.65 and an Absorption of not more than two (2) percent in accordance with ASTM Method C 127. The test for soundness shall be performed in accordance with ASTM Method C 88 for course aggregate and shall yield the following results: weight loss in five (5) cycles not more than 10 percent when sodium sulfate is used or 15 percent when magnesium sulfate is used.

Stone/Rock and Gravel shall conform to the following requirements:

1. Boulders for rock step pools shall be imported imbricated riprap.
2. Footer rocks consist of rocks placed below the invert of the proposed channel to provide support for the Vane Rocks and prevent excessive downstream scour. The footer rock size shall meet the dimensions specified on the Construction Drawings.
3. Top rocks consist of rocks placed upon Footer Rocks. Dimensions of Top Rocks shall have the dimensions identified on the Construction Drawings. Top Rocks shall not be larger than Footer Rocks.
4. Poorly Graded Gravel – Gravel for backfilling and “choking” shall be a poorly graded gravel mix consisting of river run sand, and gravel-cobble material that meets the gradation requirements indicated in the Streambed Material Gradation Table in the Construction Drawings. The source of gravel material and samples shall be provided to the Engineer for review and approval prior to commencing construction operations. Installation shall be in accordance with these specifications and as directed by the Engineer.
5. All filter fabric installed as part of the Rock Step Pool Structure shall be a non-woven fabric (MIRAFI 180N 8 oz. or approved equal).

PART 3 EXECUTION

3.1 CONSTRUCTION METHOD

Rock Step Pool Structures shall be constructed according to the Rock Step Pool Structure Detail shown on the plans or as directed by the Engineer. The elevation tolerance for in-stream structures will be +/- 0.1ft of design elevations. Footer rocks used in in-stream structures shall extend inward toward the center of the channel, past the header rocks so that the footers act as a splash rock.

The Step-Pool structures shall be constructed in a manner such that adjoining rocks taper up in elevation towards the stream bank in a downstream direction. Each side or arm of the structure is to be angled 20 to 30 degrees from the stream bank towards mid-channel.

A trench shall be excavated for the structure. The width of excavation in the direction of flow shall be a minimum of one foot wider than the structure. After the footer rocks are placed in the downstream edge of the trench, the trench shall be backfilled to the proposed invert with the specified gravel mix.

Top rocks shall be placed so that they lean on the footer rocks and fit snugly together in a puzzle-like fashion. Care should be taken when placing top rocks that the seams between top rocks do not line up with the seams between the footer rocks. The top elevation of the rocks placed at the thalweg (deepest portion of the stream) shall be equal to the elevation of the thalweg plus 0.1 to 0.2 tenths of a foot. Starting at the thalweg, adjacent rocks shall taper up (approximately 5 to 10 percent slope) to the end top rock, which shall be placed at the “bankfull” elevation.

The outermost top rock of the Step-Pool structure shall be installed with one half (1/2) the diameter of the end top rock buried into the stream bank.

Erosion Control Matting shall be keyed in between the top rock on the bank and the rock immediately below it, then folded behind and overtop the top vane rock. Reshape the slopes to specified elevations and fold the matting over the face of the slope. Key the matting back into the bank a minimum of one-foot-deep at the top of bank.

PART 4 MEASUREMENT AND PAYMENT

The Quantity of Rock Boulders Placed within the specified limits or as directed by the Project Officer will be measured to the nearest ton by actual weight. For each ton of Rock placed in constructing the aforementioned structures and Boulder Features, the Contractor shall furnish to the Project Officer a statement of delivery ticket showing the weight to the nearest 0.1 ton of rock in the load. Rock will be measured and paid for on a per ton basis installed complete and in place. Such payment will constitute full compensation for transporting, furnishing, stockpiling, and installation of Rock Structures, including removal and disposal off-site of unsuitable and surplus fill material, any required grading in and out of the streambed, backfilling or “choking”, compaction, and for all materials, labor, equipment, tools and all other items necessary and incidental to completing the work.

Rock Step Pool Structures shall be paid per quantity of stone installed for each structure and accepted by the Engineer in the field. Such price and payment shall be full compensation for the items of work, including the cost for furnishing all materials, labor, equipment, tools, and incidentals required by the above specification.

Payment will be made under:

Pay Item	Pay Unit
Rock Step Pool Structures	TONS

PART 1 – GENERAL**1.1 Description of the Work**

Provide all necessary labor, materials and equipment to provide, fabricate, and install the permanent signs, posts, and connections as shown on plans, details, and these specifications. All work under this section is subject to the Special and General Conditions and Instruction to Bidders which form a part of these specifications and to the current editions of the Arlington County Construction Standards and Specifications Manual and Virginia Department of Transportation Road and Bridge Specifications (VDOT). The Contractor shall be responsible for and governed by all the requirements thereunder.

PART 2 – MATERIALS

- 2.1 All traffic control signage shall conform to the latest edition of the Manual on Uniform Traffic Control Devices (MUTCD).
- 2.2 Sign anchors bases, or sleeve bases shall meet current AASHTO, FHWA, and VDOT requirements for breakaway and yielding and shall be galvanized or stainless steel.
- 2.3 Sign posts set in earth shall be U-type rolled rail post (2 lbs/foot) with full length punching of 3/8-inch diameter holes spaced 1 inch on center starting 1 inch from each end. Posts shall be re-rolled steel or an equivalent steel. Posts shall conform to the mechanical requirements of ASTM A-499-81, Grade 60 (Hot-Rolled Carbon Steel Bars and Shapes Re-Rolled from Rail Steel). All posts are to be hot dipped zinc galvanized.
- 2.4 The use of other than U-type posts at any location requires approval from Arlington County.
- 2.5 Where square posts are permitted the following standards must be met.
 - 2.5.1 Steel posts shall conform to ASTM A570, Grade 50 for Hot-Rolled Carbon Sheet Steel.
 - 2.5.2 Post cross section shall be square formed from 14 or 12-gauge steel and shall be welded at the corner.
 - 2.5.3 Posts shall be straight and have a smooth finish.
- 2.6 Banding used with saddles and buckles to fasten sign panels to streetlight or signal poles shall be stainless steel with a minimum width of ¾ inch.
- 2.7 Saddles shall be stainless steel with stainless steel bolts.
- 2.8 Buckles shall be stainless steel with a minimum width of ¾ inch.
- 2.9 Fasteners shall be 3/8" O.D. galvanized bolts with nylon washer for the sign front and galvanized hex nut and washer for the sign back.

- 2.10 Sign surface image shall conform to applicable portions of Sections 247 and 701 of the VDOT Road and Bridge Specifications. The sign colors and backgrounds shall conform to the details. Colors and shop drawings of signs shall be approved by the Owner prior to fabrication. Sign shall be drilled for bolts prior to painting
- 2.11 Post footings shall be Class A-3 concrete per Section 03100 of the Arlington County Construction Standards and Specifications Manual

PART 3 – EXECUTION

- 3.1. The signs shall be installed in locations as shown on the plans.
- 3.2. Posts located in earth shall be anchored or driven to a minimum depth of 36 inches.
- 3.3. Driving caps shall be used when driving posts following the manufacturer’s instructions.
- 3.4. Posts located in concrete sidewalk or concrete medians A 12-inch minimum diameter cylindrical excavation to depth shown on detail shall be made to install the sign post. The post shall extend 36" (thirty-six inches) minimum below finished grade.
- 3.5. Concrete for footings shall be poured in accordance with the requirements outlined in the Section 03100 of the Arlington County Construction Standards and Specifications Manual.
- 3.6. The sign shall be centered on the post and fastened with the specified bolts. The lower edge of the signs shall be to the dimension above finished grade as shown on the details for each sign type.

PART 4 – MEASUREMENT AND PAYMENT

- 4.1 New Traffic Sign
New Traffic Signs as shown on the Drawings and as specified herein shall be measured in units of each, complete-in-place. Payment will be at the contract unit price per each, and shall include the furnishing of all signs, posts, concrete, fastening materials, and other material required to provide a complete sign installation, as well as all other work incidental to providing a complete installed sign.
- 4.2 Relocate Traffic Sign
Relocate Traffic Sign as shown on the Drawings and as specified herein shall be measured in units of each. The Project Officer may allow the Contractor to reuse the sign, post, or related hardware for re-installation at the new location, subject to approval by the Project Officer. If the Project Officer determines that the sign, post, or hardware is damaged or does not meet this specification; and that the reinstallation of any or all of the materials will not result in a satisfactory traffic sign installation the Contractor shall furnish and install new materials as required to provide a complete-in-place traffic sign.

This Section is an addendum to the Arlington County Department of Environmental Services Construction Standards and Specifications for this Contract. The Live Stakes attachment is incorporated by reference. Where these special provisions conflict with or modify the Live Stakes attachment, these provisions shall govern.

PART 1 – GENERAL

1.1. Description of Work

Furnishing and installing live stakes on stream banks and other areas as applicable to the plans and details. Live staking is a standard bioengineering technique which involves planting of dormant plant cuttings using species known to produce roots from cuttings.

The quantity of live stakes to be installed will be affected by the actual conditions that occur during the construction of the project. The quantity of live stakes may be increased, decreased, or eliminated entirely as directed. Such variations in quantity will not be considered as alterations in the details of construction or a change in the character of the work.

1.2. Related Work Specified Elsewhere

Arlington County Department of Environmental Services Construction Standards and Specifications (Arlington County Specifications):

Section 02100 - Clearing and Grubbing

Section 02200 – Earthwork for Structures and Pipelines

Section 02801 - Seeding and Sodding

Section 02800 – Landscaping

1.3. Applicable Specification

Live Stakes attachment

1.4. Applicable Reference

Erosion and Sediment Control Ordinance (Chapter 57 of the Arlington County Code)

1.5. Submittals

Prior to purchasing or harvesting live stakes, the contractor will submit a list of the species to be obtained with quantities, the length and caliper of the stakes to be provided, and the provenance of the material for approval by the Project Officer.

PART 2 – MATERIALS

2.1 Live stake Cutting

Live stake cuttings shall be approximately one half inch to one and one half inches (0.5" to 1.5") in diameter. Cuttings will not exceed two inches (2") in diameter and shall not be less than 0.25" in diameter. Cuttings shall be two feet (2') to three feet (3') in length and reasonably straight.

Live stakes shall be cut at a 45° angle at the basal end and cut flat on the top end. The basal end is the end that will take root and will be the end installed in the ground.

Live stake cuttings shall consist of a mix of two (2) or more of the approved plant species as set forth in the construction documents. Species selection and percentages may be adjusted based on availability and approval of the Engineer prior to purchase and installation. Final locations and configurations will be determined in the field by the Engineer.

PART 3 – EXECUTION

Plant material with excessive damage or oblique cuts, or with excessive damage to the bark, will not be acceptable. All live materials shall be properly stored to insure viability. Contractors shall protect plant materials from drying and overheating during transport and during the installation process.

Live plant material shall receive continuous shade and well as protection from the wind. Shade fabric, heeling, mulches, plastic and watering are all techniques that may be used.

Live stake harvesting and installation shall occur subsequent to December 1 and prior to April 1.

Live stakes will be installed in the ground using a dead blow hammer. The top end of the stake will protrude approximately 3" above the finished ground elevation. On sloped ground surfaces, stakes will be installed perpendicular to the finished grade slope.

The Live Stakes/Posts shall be placed so that 80% of their length is buried. All live stakes shall be planted such that the stake is tamped, and has full contact between the soil and cutting. In the event of hard ground, a 0.5" metal bar may be used to initiate a pilot hole for live stakes. The rod must be carefully removed without rotating to enlarge the hole.

Live Stake/Posts shall be installed at the spacing and density as shown in the project drawings or as directed by the Engineer. Typical spacing for Live Stakes will be 2'-3' apart using a diamond-pattern spacing.

Live stakes should not be split during installation. Live stakes which are split shall be removed and replaced, or if the split is less than 1/6 of the cutting length, the top may be re-trimmed after installation to remove the damaged portion.

The Contractor shall replace any dead live stakes with bare root plants to account for the lost year of growth. The replacement plants shall be the same species as the dead live stake unless otherwise

approved by the Engineer. The Contractor is required to replace said plants prior to November 15 of the same year. All replacement plants shall be furnished and installed in accordance with the relevant technical specifications.

PART 4 – MEASUREMENT AND PAYMENT

Live stakes will be measured and paid for at the unit price per stem. Such payment shall be considered full compensation for the item of work, including the cost for furnishing all materials, labor, equipment, incidentals, storage, preparation and planting of the live stakes.

PART 1 – GENERAL4.6 Description of The Work

Provide all labor, materials, tools, equipment, transportation, supplies, and incidentals to establish the location of pavement markings, install pavement markings, and reflectorized material on specified pavements in accordance with these specifications, the MUTCD, and as directed by the Engineer.

This work shall also include furnishing and installing colored coating for bicycle lanes.

PART 2 - MATERIALS2.1 Pavement Markings

Pavement Markings shall conform to the requirements of Section 246 of the VDOT Road and Bridge Specifications.

2.2 Glass Beads

Glass Beads shall conform to the requirements of section 234 of the VDOT Road and Bridge Specifications.

2.2 Colored Asphalt Coating

Colored asphalt coating shall be Street Bond CL by Quest Construction Products or County approved equal. Color shall be Emerald Green. Verify color with County prior to ordering.

PART 3 – EXECUTION4.1 Timing of Installation

The Contractor shall have a certified Pavement Marking Technician present during pavement marking operations.

Pavement markings shall be installed on new roadways prior to opening the roadway to traffic. Pavement marking installation shall be completed within the time limits herein on roadways where the pavement markings have been removed or obscured and the roadway is open to traffic unless otherwise directed by the Engineer. Installation of Type B, Class VI, pavement markings on asphalt roadways are not applicable to these requirements if they are inlaid with the last pass of the asphalt roller or directly after the asphalt roller using a separate roller. Installation of edge lines on roadways where the existing pavement markings have been removed or obscured are also required within these time limits unless otherwise indicated by the Engineer.

Exceptions to the below time limits will be granted only for weather restrictions, and installation of epoxy resin pavement markings on new pavement shall not commence until after 24 hours of final surface placement.

Pavement marking installation on roads having traffic volumes of 10,000 ADT or more shall be completed within 24 hours after the end of the workday where the pavement markings were removed or obscured.

Pavement marking installation on roads having traffic volumes between 3,000 and 10,000 ADT shall be completed within 48 hours after the end of the workday where the pavement markings were removed or obscured.

Pavement marking installation on roads having traffic volumes of less than 3,000 ADT shall be completed within 72 hours after the end of the workday where the pavement markings were removed or obscured.

4.2 Provision for Temporary Markings

If the Contractor will not have pavement markings installed within the time limits specified, the Contractor shall install Type D construction pavement markings within the same time limits and maintain such until the final pavement markings can be installed. The cost of installing, maintaining, and removing the Type D construction pavement markings shall be borne by the Contractor at no cost to the County.

When establishing the location of pavement markings, the Contractor may mark the locations on the roadway by installing pre-markings.

Pre-markings shall be accomplished using Type D (removable, any class) tape, chalk, or lumber crayons except special pavement markings such as stop lines, crosswalks, messages, hatching, etc., shall be made using chalk or lumber crayons. Pre-markings shall be of the same general color as the pavement markings being pre-marked. When tape is used as pre-marking, pre-marking shall consist of 4-inch by 4-inch-maximum squares or 4-inch-maximum diameter circles spaced at 100-foot-minimum intervals in tangent sections and 50-foot-minimum intervals in curved sections. At locations where the pavement marking will switch colors, e.g., gore marking, the ends of the markings may be pre-marked regardless of the spacing. When chalk or lumber crayon is used as pre-marking, the entire length of the pavement marking may be pre-marked.

Pre-markings shall be installed whereby their installation shall not affect the adhesion of the pavement markings. When Type D tape is used as the pre-marking and the lateral location of such pre-markings to the final pavement markings exceeds 6 inches, the pre-markings shall be removed at no cost to the County.

4.3 Pavement Markings

Pavement markings shall be white or yellow markings as required by the MUTCD for the specific location or as specified by the Engineer and shall be installed in accordance with the manufacturer's recommendations and approved by the Engineer. The Contractor shall furnish a copy of the manufacturer's installation recommendations to the Engineer.

4.4 Pavement Line Markings

Pavement line markings shall consist of stop lines, crosswalks, and solid or skip lines used for, but not limited to, dividing lanes, marking edges, channelizing, outlining and marking safety

zones around objects, and forming islands and parking lot stalls. Crosswalks and stop lines shall be installed using Type B, Class I or IV, markings. Solid lines or skip lines shall be installed using Type A or Type B markings as specified.

4.5 Pavement Message Markings

Pavement message markings shall be installed using Type B, Class I, IV, or VI, markings and shall include, but not be limited to, school zone markings, railroad crossing markings, disabled parking symbols, elongated arrows, word messages, etc.

The word SCHOOL shall be formed with characters that are 10 feet in height where permitted by the normal roadway width. School zone markings shall extend transversely across both lanes of two-lane roadways and across two or more approach lanes of roadways of three or more lanes.

Disabled parking symbols shall be 41 inches in height, 36 inches in width, and shall use a 4-inch stroke width for the lines.

4.6 Application

The Contractor shall protect the public from damage attributable to pavement marking operations. The Contractor shall be responsible for the complete preparation of the pavement surface, including, but not limited to, removing dust, dirt, loose particles, oily residues, curing compounds, concrete laitance, residues from eradication, and other foreign matter immediately prior to installing pavement markings.

The pavement surface shall be dry at the time of installation. Marking material shall not be applied within 24 hours following rain or other inclement weather.

Liquid markings shall be applied so as to prevent splattering and overspray and shall be protected from traffic until track free by the use of guarding or warning devices as necessary. If a vehicle crosses a marking and tracks it or if splattering or overspray occurs, the affected marking and resultant tracking shall be removed and new markings applied at the Contractor's expense.

Equipment shall also be thoroughly cleaned between changes in colors of materials. Pavement markings shall have clean and well-defined edges without running or deformation; shall be uniform, free of waviness; shall be straight on tangent alignment; and shall be on a true arc on curved alignment.

4.7 Tolerance

The widths of pavement markings shall not deviate more than 1/4 inch on tangent nor more than 1/2 inch on curves from the required width. The length of the gap and the length of the individual stripes that form skip lines shall not deviate more than two inches. The length of the gap and individual skip line shall be of such uniformity throughout the entire length of each that a normal striping machine will be able to repeat the pattern and superimpose additional striping upon the existing marking.

4.8 Glass Beads

Glass beads shall be applied at the rate specified herein and shall be evenly distributed over the entire surface of the marking. Beads shall be applied to the surface of liquid markings by a bead dispenser attached to the applicator that shall dispense beads simultaneously on and in the just-applied marking. The bead dispenser shall be equipped with a cut-off control synchronized with the cut off of the applied marking material so that the beads are applied totally to the completed line.

Beads shall be applied while the liquid marking is still fluid. Approximately 70 percent of beads shall be buried in the marking, and the remaining 30 percent shall be 50 to 60 percent embedded in the surface. Beads installed on crosswalks and stop lines on roadways with curbs only (no gutter) may be hand applied for two feet at the end of each line next to the curb with 100 percent of the beads embedded 50 to 60 percent in the surface.

Markings found to be unacceptable shall be removed, and new markings applied at the Contractor's expense.

4.9 Type A Markings

Paint may be applied to asphalt concrete and hydraulic cement concrete pavements. Paint shall not be applied over existing pavement markings of other materials unless the existing marking is 90 percent removed. Paint may be applied over existing paint markings. Paint shall be applied with a line painting machine that is capable of hot spraying paint directly onto the pavement surface with a uniformity of feed through its nozzles for widths of 4 through 8 inches. The machine shall be capable of applying two pavement stripes, either solid or skip, at the same time when double line markings are required. Paint tanks on the equipment shall be equipped with a mechanical agitator and paint shall be thoroughly mixed and heated such that it will not track within 60 seconds after its application.

Non-truck mounted equipment shall be self-propelled and regulated to allow for calibration of the amount of material applied. Glass beads shall be applied to the surface of the paint at the rate of 6 pounds per gallon of paint.

4.10 Type B Markings

Equipment shall be capable of providing mixing, heating, and agitation of material. Material shall be uniformly heated throughout the system in accordance with the manufacturer's recommendations. Thermoplastic material shall be maintained in the heating kettle and applied to the road surface at a minimum temperature of 400 degrees F. Heating kettles shall be equipped with an automatic thermostatic control device. The Contractor shall furnish a properly calibrated infrared instrument for the purpose of measuring the actual temperature of molten thermoplastic material.

Multi-component material shall be applied using internally injected guns for the mixing of catalyst and hardener.

Non-truck mounted equipment for application of thermoplastic material shall be of the screed extrude type with a screw driver or shall be self-propelled and regulated to allow for calibration of the amount of material applied. Non-truck mounted equipment for application of polyester and epoxy resin material shall be self-propelled and regulated to allow for calibration of the amount of material applied.

4.11 Thermoplastic (Class I)

Thermoplastic (Class I) material shall be applied only on asphalt concrete pavements and shall be applied by screed extrude, ribbon gun, or spray equipment. Alkyd thermoplastic may be applied directly after the paving operations; however, hydrocarbon thermoplastic shall not be applied less than 30 days after the paving operations.

Alkyd and hydrocarbon materials shall not be mixed together. Equipment shall be thoroughly cleaned before types of material are changed.

Thermoplastic shall not be applied over existing pavement markings of other materials unless the existing marking is 90 percent removed. Thermoplastic may be applied over existing thermoplastic markings. For concrete bridge decks that occur in asphalt roadways, Type B, Class VI, tape shall be used.

Primer/adhesive shall be applied to asphalt concrete surfaces more than 2 years old and shall be from the same manufacturer as the thermoplastic.

Glass beads shall be applied to the surface of the marking at the rate of 7 pounds per 100 square feet.

4.12 Polyester Resin (Class II)

Polyester resin (Class II) material shall be applied only on hydraulic cement concrete pavements. Polyester resin shall not be applied over existing pavement markings of other materials unless the existing marking is 90 percent removed.

Polyester resin may be applied over existing polyester resin markings.

Glass beads shall be applied to the surface at the rate of 8 pounds per gallon of material.

4.13 Epoxy Resin (Class III)

Epoxy resin (Class III) material shall be applied only to asphalt concrete pavement more than 1 day old and hydraulic cement concrete pavement. Epoxy resin shall not be applied over existing pavement markings unless the existing marking is 90 percent removed.

Glass beads shall be applied by the gravity method to the surface at the rate of 25 pounds per gallon of material.

4.14 Plastic Backed Preformed Tape

Plastic-backed preformed tape shall be installed in accordance with the manufacturer's recommendations and as denoted herein. Tape may be applied to asphalt concrete and hydraulic cement concrete pavements. Tape may be installed immediately following the final

rolling of the new asphalt concrete surface. Tape shall not be applied over existing pavement markings of other materials unless the existing marking is 90 percent removed.

Primer/adhesive shall be used for all installations except when tape is applied immediately following the final rolling of the new asphalt concrete surface and shall be from the same manufacturer as the tape.

Tape for pavement line markings shall be applied by an application cart as recommended by the manufacturer. Tape shall be tamped into place with a tamper cart with the weight as recommended by the manufacturer. The use of a vehicle to ride over the markings for tamping will not be permitted.

4.15 Eradication

Eradication of pavement markings for restriping when required shall be in accordance with the requirements of Section 512 of the VDOT Road and Bridge Specifications except only 90 percent removal of the existing markings is required.

4.16 Colored Asphalt Coating

Installers shall be accredited by the manufacture. Materials shall be installed in accordance with the manufacturer's written instructions. The Contractor shall apply a minimum of two coats.

PART 4 – MEASUREMENT AND PAYMENT

4.1 Pavement Line Marking

Measurement of pavement line markings (type, class, width) shall be per linear foot of line furnished and installed.

No additional measurement will be made when more than one line can be installed on a single pass such as center line with no-pass line, double center line, double lane line, reversible lane line, or two-way left turn center line.

Payment for pavement line markings (type, class, width) shall be per linear foot and shall include all labor, materials, tools, equipment, transportation, supplies, and incidentals required to furnish and install the line markings as specified.

No deduction will be made for the unmarked area when the marking includes a broken line such as, skip lane line.

4.2 Colored Asphalt Coating

Measurement of colored asphalt coating shall be per square foot of area completed. Payment for colored asphalt coating shall be per square foot and shall include all labor, materials, tools, equipment, transportation, supplies, and incidentals required to complete the coating.

PART 1 – GENERAL

This work shall consist of maintaining and protecting workers, vehicular and pedestrian traffic through areas of construction within the limits of the project and over the approved traffic detours. All work shall be in accordance with the latest Arlington County Construction Standards and Specifications, Virginia Department of Transportation (VDOT) Road and Bridge Specifications, the Manual on Uniform Traffic Control Devices (MUTCD), and the Virginia Work Area Protection Manual (WAPM), the standard drawings, and the Contract, as directed by the Project Officer.

1.1 Description of Work

Provide all plant, labor, supervision, materials, and equipment to install, maintain, relocate, and remove all temporary traffic control devices.

1.2 Related Work Specified Elsewhere

1.3 Applicable Specifications

- A. Virginia Department of Transportation (VDOT)
- B. VDOT Road and Bridge Specifications
- C. Manual on Uniform Traffic Control Devices (MUTCD)
- D. Virginia Work Area Protection Manual (WAPM)
- E. Occupational Safety and Health Act, State & Federal (OSHA)

1.4 Quality Assurance

28. Work Zone Traffic Control Certification

The Contractor shall have at least one (1) employee who is certified by VDOT in Basic Work Zone Traffic Control; and who will be responsible for the placement, maintenance and removal of work zone traffic control devices within the project limits in compliance with the permit requirements and conditions, the approved plan, specifications, the Virginia Work Protection Manual and the Manual of Uniform Traffic Control Devices. An Employee certified by VDOT in the Intermediate Work Zone Traffic control shall be on-site to provide supervision during work zone adjustments or changes to traffic control due to field conditions. This employee shall provide evidence of this certification upon request from Arlington County personnel.

PART 2- MATERIALS

2.1 General

Material shall conform to the requirements of the applicable VDOT specification.

2.2 Signalization, Barricades, Channelizing Devices, Safety Devices, and Pavement Markings

Signalization, barricades, channelizing devices, safety devices, and pavement markings shall conform to the requirements of Division VII of the latest VDOT specifications and the MUTCD.

- 2.3 Temporary Pavement Markers
Temporary pavement markers shall conform to the requirements of VDOT Section 235, Retroreflectors.
- 2.4 Construction Pavement Markings
Construction pavement markings shall conform to the requirements of VDOT Section 231 (Paint), and Section 246 (Pavement Marking).
- 2.5 Portable Changeable Message Signs
Portable changeable message signs shall meet the requirements of Section 512.03 subsection q of the VDOT Road and Bridge Specifications.

PART 3- EXECUTION

This section shall conform to the VDOT Specification Section 512.03.

PART 4- MEASUREMENT AND PAYMENT

Payment for MOT shall be based on the bid form. The payment will be a multiplier, expressed as a percentage, to be added to the total amount of the project assignment cost (applied only to the amount being invoiced). There will be no escalation for MOT percentage multiplier for the initial contract term and the extensions thereafter

The Contractor shall not be entitled to any additional payment for changes to MOT which are the result of the Contractor's work schedule or resource allocation, weather delays, or other factors not controlled by the County.

Payment for maintenance of traffic is full compensation for providing the proper pedestrian and vehicular traffic controls during all stages of construction and includes furnishing, preparing, fabricating, installing, maintaining, removing, relocating, repairing, or replacing pedestrian and vehicular traffic control devices and signs as necessary, and all other materials, labor, hardware, equipment, tools, supplies, and incidentals. Contractor shall be responsible for acquiring VDOT permit for any revision during construction and/or as required by the project contract to the approved traffic control plan.

Payment for maintenance of traffic for each site will be made as partial payments. The first installment of 50 per cent of the unit price for maintenance of traffic will be made on the first progress estimate following partial mobilization and initiation of construction work for the particular site. The remaining 50% of the contract lump sum price bid will be paid on each subsequent estimate based on the percent of work completed at the site all the way through Final Acceptance of work. The Project Officer shall have the authority to decide on the appropriate payment for each subsequent estimate.

1.01 SUMMARY

A. This Section includes the following:

a. Protection of existing trees to remain:

- i. Pruning of existing trees roots that are affected by execution of the Work, whether temporary or permanent construction.
- ii. Aeration and Root Protection Matting
- iii. Tree Protection Fencing

PRODUCT DATA SHEET 1 - Provide all labor, materials, tool and equipment as required to have tree protection applied on all areas called for on plans.

PRODUCT DATA SHEET 2 - In addition to the specifications contained herein, Work shall be performed in accordance with the Arlington County Department of Parks & Recreation Design Standards for Tree Protection and Trimming as shown on plans and available online at:

<http://parks.arlingtonva.us/design-standards/>

PRODUCT DATA SHEET 3 - Related Sections:

1. 02200 Earthwork
2. 02100 Clearing and Grubbing
3. 01500 Erosion and Sediment Control and Pollution Prevention
4. 329000 Exterior Plants
5. 329200 Seeding and Sodding

1.02 DEFINITIONS

- A. Finish Grade: Elevation of finished surface of planting soil.
- B. Imported Topsoil: Soil obtained off-site that meets the specifications herein for topsoil and is suitable for use in planting soil/backfill soil mixture when existing soil quantities are insufficient. Refer to Section 329100 "Planting Preparation."
- C. Planting Soil/Backfill Soil Mixture: Existing soil modified as specified to be suitable for planting. Refer to Section 329100 "Planting Preparation."

- D. Subgrade: Surface or elevation of subsoil remaining after completing excavation, or top surface of a fill or backfill, before placing planting soil.
- E. ISA: International Society of Arboriculture
- F. CBAY: Chesapeake Bay, typically referring to CBAY watershed.
- G. Urban Forester/County Urban Forester: Refers to the Arlington County Urban Forester
- H. Landscape Architect: Refers to an Arlington County Landscape Architect or their designee.

1.03 SUBMITTALS

- A. Product Data: For each type of product indicated in Section 2.0
- B. Certification: From Contractor's arborist, certifying that trees indicated to remain have been protected during construction according to recognized standards and that trees were promptly and properly treated and repaired when damaged.
- C. Maintenance Requirements: From Contractor's arborist, for care and protection of trees affected by construction during and after completing the Work.
- D. Contract arborist Qualifications: Contractor shall submit a copy of valid ISA certification to the Project Officer for approval with confirmation by Urban Forester.
- E. List products to be used and firms, including qualifications to perform work.
- F. Provide schedules for performance of work.

1.04 QUALITY ASSURANCE

- A. Contractor shall ensure that tree and plant protection methods are implemented by an arborist Certified by the International Society of Arboriculture (ISA) to provide for the care of the trees and plants impacted by construction activities. Provide ISA certification verification to Project Officer per section 1.03 "Submittals" prior to beginning work.
- B. The Contractor shall identify to the Project Officer at least one authorized on-site Point of Contact(POC) who is, by training or experience, familiar with the policies, regulations and standards applicable to the work being performed. The POC and the certified arborist may be the same individual.
- C. Crews shall be directly supervised by an ISA certified arborist.

- D. All workers, through related training and on the job experience, shall be familiar with the technical aspects of arboricultural work and equipment used in such operations.
- E. Trucks and mechanized equipment shall not enter tree protection areas.
- F. Stump grinding shall be with small machines specifically designed for that purposes. No stumps shall be excavated except as described herein. Stumps shall be ground not more than 8” below grade and care must be taken to minimize damage to root of the trees to remain.
- G. No stump grinding within tree protection areas.
- H. All work in or near tree protection areas shall be carefully performed by Contractor in order to avoid damage to tree trunks, branches, root system, and other existing plant materials and soils that are to remain.
- I. Silt shall not be allowed to collect in preservation or reforestation areas. Silt accumulating in preservation areas shall constitute damage and will require remedial activity. All silt shall be removed from preservation areas within 24 hours of siltation. The methods and procedures for silt removal within tree preservation and reforested areas shall be approved by the Project Officer with confirmation by the Urban Forester.
- J. Tree Pruning Standard: Comply with ANSI A300 (Part 1), "Tree, Shrub, and Other Woody Plant Maintenance--Standard Practices (Pruning)."
 - a. Pruning shall remove only dead, dying, damaged or broken limbs greater than 1” – 1.5” in diameter.
 - b. Pruning for clearance shall be reviewed and approved by Project Officer with confirmation by the Urban Forester.
- K. Urban Forester Notification: The Contractor shall notify the Project Officer 72 hours prior to the following events, so that the County’s Urban Forester can be notified and present at a pre-construction site meeting (refer to Section 3) and to observe work:
 - 1. Tree protection fencing installation
 - 2. Tree or root-pruning operations.
 - 3. Work within tree protection zones.
 - 4. Tree planting.

PART 2 - PRODUCTS

2.01.1 MATERIALS

- A. Temporary Tree Protection Fence: Unless otherwise indicated in approved plans, tree protection fence shall be two-inch wire mesh fabric measuring 72 inches in height mounted on 1.9" O.D. steel pipes driven 24 inches into the ground, placed 120 inches on-center maximum. Refer to Arlington County DPR standard detail on approved plans.
- B. Tree Protection Signs: Shall be of heavy-duty sheet aluminum or weatherproof plastic material measuring 12 inches by 18 inches. Signs shall state "NO ENTRY, TREE PROTECTION AREA, CALL 703-228-6557 TO REPORT VIOLATIONS" in both English and Spanish. Signs shall be mounted on fence every 50 feet maximum.
- C. Topsoil: Refer to Section 329100 – Plant Preparation.
- D. Bark Mulch: Refer to Section 329100 –Plant Preparation
- E. Temporary Root Protection Matting: If required in approved plans, temporary root protection matting shall be a double-sided geo composite, geonet core, non-wove covering such as Tendrain 770-2, as manufactured by Tenax Corporation, Baltimore, MD or approved equal. Six (6) inches of wood chip mulch shall be applied to area to receive root protection matting prior to installation. Matting shall be installed in a single layer.
- F. Landscape nails: When required, spikes shall be 12" as indicated on the drawings.

PART 3 - EXECUTION

3.01 PREPARATION

- A. Prior to the construction activities, the Contractor shall meet on-site with the Project Officer and Urban Forester to review trees to remain and protective measures required.
- B. Temporary Tree Protection Fencing: Install temporary tree protection fencing and signs around tree protection zones to protect remaining trees and vegetation from construction damage. Maintain temporary fence and remove when construction is complete after approval by Project Officer with confirmation by the County Urban Forester.
- C. Protect tree root systems from damage caused by runoff or spillage of noxious materials while mixing, placing, or storing construction materials. Protect root systems from ponding, eroding, or excessive wetting caused by dewatering operations.
- D. No personnel, vehicles, equipment, construction materials, or construction debris shall be allowed inside the tree protection areas at any time during construction without the written

- E. consent of the Project Officer with confirmation by the Urban Forester. If a violation is observed, the Contractor will be notified by the Project Officer and shall immediately rectify the situation. Continued and subsequent violations will result in a fine of \$500 per day of violation.
- F. Special Demolition Procedures:
 - 1. Demolition of walks and hardscape within tree protection areas shall be directly supervised by an ISA certified arborist.
 - 2. Mechanized equipment shall not enter tree protection areas (TPAs) or reforestation areas.
 - 3. Backfill of voids created by demolition within the TPAs and reforestation areas shall be loosely placed topsoil. Only the amount of topsoil necessary to fill the void without spreading over existing grades shall be allowed.

3.02 EXCAVATION

- A. Install shoring or other protective support systems to minimize sloping or benching of excavations if indicated in the approved plans.
- B. Do not excavate within tree protection zones, unless otherwise indicated.
- C. Where utility trenches are required within tree protection zones, Contractor shall perform root pruning prior to trenching.
- D. Where excavation is proposed within the critical root zone of trees to remain, Contractor shall perform root pruning as indicated in approved plans prior to excavation.
- E. Where new finish grade is indicated below existing grade around trees, Contractor shall slope grade outside of tree protection zones. Maintain existing grades within tree protection zones.

3.3 ROOT PRUNING:

- A. When required, root pruning locations will be indicated on the approved plans. Exact location and depth shall be determined on site with Project Officer and Urban Forester during the pre-construction meeting.
- B. Do not cut main lateral roots or taproots; cut only smaller roots that interfere with installation of utilities. Cut roots with clean, sharp pruning instruments; do not break or chop. All root pruning shall be performed by an ISA certified arborist. Refer to Arlington County Department of Parks & Recreation Design Standards "Tree Protection and Trimming" as shown on plans and available online at:

<http://parks.arlingtonva.us/design-standards/>

3.4 TREE REPAIR AND REPLACEMENT

- A. Promptly repair trees damaged by construction operations within 24 hours. Treat damaged trunks, limbs, and roots according to Arlington County Urban Forester or contract arborist's written instructions.
- B. The Contractor shall be responsible for any damage to trees within the Tree Protection Area caused by the Contractor's personnel, vehicles, or equipment at the site. Any damage to a tree to remain shall result in a payment by the Contractor to the Project Officer for the amount of damage based on the latest edition of the Council of Tree and Landscape Appraisers Guide for Plant Appraisal published by the International Society of Arboriculture (ISA). All trees are to be valued as landscape trees.

3.5 DISPOSAL OF WASTE MATERIALS

- A. Burning is not permitted.
- B. Disposal: Remove excess excavated material and displaced trees from Owner's property and legally dispose.

PART 4 – MEASUREMENT AND PAYMENT

- 4.1 The measurement of TREE PROTECTION FENCE shall be for LINEAR FOOT of fence including all appurtenances as delivered to the site, furnished, installed, maintained and removed at project completion in accordance with the plans and specifications.
- 4.2 The unit price for Tree Protection Fence shall include the cost of all labor, materials, equipment and incidental expenses necessary to complete the work.
- 4.3 The measurement of ROOT PRUNING shall be for LINEAR FOOT of pruning root pruning performed on the project in accordance with the plans and specifications.
- 4.4 The unit price for ROOT PRUNING shall include the cost of all labor, materials, equipment and incidental expenses necessary to complete the work.
- 4.5 The measurement of ROOT PROTECTION MATTING shall be for SQUARE FOOT of matting as delivered to the site, furnished, installed, maintained and removed at project completion in accordance with the plans and specifications.
- 4.6 The unit price for ROOT PROTECTION MATTING shall include the cost of all labor, materials, equipment and incidental expenses necessary to complete the work including anchor/landscaping nails, in accordance with the approved plans and specifications. Unless otherwise specified on the approved plan, excavation for ROOT Protection Matting installation is considered incidental to the work and shall not be paid separately.

PART 1 - GENERAL

1.01 SUMMARY

- A. This Section includes erosion control materials, soil amendments, mulching and topsoil.
- B. Provide all labor, materials, tools and equipment as required to have topsoil, planting soil mix, soil stabilization, amendments, and mulch applied per the specifications on all areas disturbed by construction to receive plant materials as indicated in the approved plans.
- C. Related Sections:
 - a. Section 02200 Earthwork
 - b. Section 02100 Clearing and Grubbing
 - c. Section 311300 Tree Protection and Root Pruning
 - d. Section 01500 Erosion and Sediment Control and Pollution Prevention
 - e. Section 329200 Seeding and Sodding
 - f. Section 329300 Exterior Plants
- D. In addition to the specifications contained herein, Work shall be performed in accordance with the:
 - a. Drawings and general provisions of the contract, including general and supplementary conditions
 - b. Arlington County Department of Parks & Recreation Design Standards as shown on the plans and available online at:
<http://parks.arlingtonva.us/design-standards/>

1.02 DEFINITIONS

- A. Finish Grade: Elevation of finished surface of planting soil.
- B. Imported Topsoil: Soil obtained off-site that meets the specifications herein for topsoil and is suitable for use in planting soil/backfill soil mixture when existing soil quantities are insufficient.

- C. Planting Soil/Backfill Soil Mixture: Existing soil modified as specified to be suitable for planting.
- E. Subgrade: Surface or elevation of subsoil remaining after completing excavation, or top surface of a fill or backfill, before placing planting soil.
- F. ISA: International Society of Arboriculture
- G. CBAY: Chesapeake Bay, typically referring to CBAY watershed.
- H. Urban Forester/County Urban Forester: Refers to the Arlington County Urban Forester
- I. Landscape Architect: Refers to an Arlington County Landscape Architect or their designee.

1.03 SUBMITTALS

- A. Samples of all materials specified shall be submitted to the Project Officer for approval with coordination of the Landscape Architect. All approvals shall be in writing.
- B. Samples:
 - a. Existing Topsoil: Provide 1-pound sample of existing topsoil with the following soil test reports.
 - i. Fertility: pH, nitrate nitrogen, ammonia nitrogen, phosphate phosphorous, potassium, calcium, magnesium, zinc, iron, manganese.
 - ii. Suitability: total salinity, boron, sodium, potassium, calcium, magnesium, chloride, sulfate.
 - iii. Physical properties including organic content and particle size distribution.
 - b. Imported Topsoil: If imported topsoil is required, Contractor shall provide a 1-pound sample of the imported topsoil with the soil test reports as noted above for "Existing Topsoil."
 - c. Imported Topsoil for Bioretention Areas: If bioretention areas are indicated in the approved plans, the Contractor shall submit soil sample per specifications.
 - d. Mulches and Organic Matter/Compost: Sample of mulch and organic matter/compost may be requested in lieu of inspection.

- e. Product certificates: Contractor shall submit for each type of manufactured product, to be approved by the Project Officer in coordination with Landscape Architect or Urban Forester and complying with the following:
 - a. Manufacturer’s certified analysis for standard products.
- f. Geotextile/Soil Stabilization/Erosion Control Fabric: Sample

1.04 QUALITY ASSURANCE

- A. Contractor shall have all existing and furnished topsoil to be used for seeding and sodding, and for planting areas tested by a state laboratory or recognized commercial soil-testing laboratory in order to determine recommendations for the types and quantities of soil amendments. The results of this test will determine the rates and types of fertilizers, lime, soil conditioners, and other amendments, if necessary.
 - a. Soil tests shall use a representative sample of on-site soils. If existing soil has been undisturbed and is suitable as determined by the soil test, no additional amendments are required.
 - b. Adjustments should be made based on soil test results.

PART 2 - PRODUCTS

2.01 MATERIALS

- A. All materials shall conform to those stipulated below, unless otherwise approved in writing by the Project Officer with confirmation by the Landscape Architect or County Urban Forester.
- B. Specified materials to be applied in amounts and methods herein stipulated.
- C. Delivery tickets indicating date, weight, analysis and vendor's name, to be submitted to Project Officer.

2.02 SOIL AMENDMENTS

- A. Lime: Application rates for liming materials and lime material type chosen shall be determined by required soil tests and approved by the Project Officer in coordination with the Landscape Architect or Urban Forester.

- a. When required and unless test results indicate otherwise, lime material shall be dry and free flowing pulverized limestone, hydrate lime or burnt lime that contains at least 50% total oxides (calcium oxide plus magnesium oxide). Ground limestone shall be ground to such fineness that at a minimum of 50% will pass through a 100% mesh sieve and 98% - 100% will pass through a 20 mesh sieve. Lime material shall meet the Virginia Agricultural Liming Materials Act, Code of Virginia Section 3.1-126.1.

- B. Fertilizer: Fertilizer type and application rate shall be determined by results of required soil tests and approved by the Project Officer in coordination with the Landscape Architect or Urban Forester:
 - a. When required and unless test results indicate otherwise, commercial-grade complete fertilizer will be of neutral character, consisting of fast- and slow-release nitrogen, 50 percent derived from natural organic sources of urea formaldehyde, phosphorous, and potassium in the following composition:
 - i. Composition: 10 percent nitrogen, 20 percent phosphorous, and 10 percent potassium, by weight.

 - b. All fertilizers shall be uniform in composition, free flowing, and suitable for application with approved equipment.

 - c. Fertilizers shall be delivered to the site fully labeled according to applicable state fertilizer laws and shall bear the name, trade name, or trademark and warranty of the product.

- C. Delay mixing fertilizer with planting soil if planting will not proceed within 2 days.

- D. Spread fertilizer and lime with approved equipment.

2.03 EXISTING TOPSOIL

- A. Existing, native surface topsoil formed under natural conditions with the duff layer retained during excavation period and stockpiled.
 - a. Contractor shall verify suitability of stockpiled soil to produce or to be amended to produce viable planting soil for lawns and planting beds as described herein.

- B. Existing topsoil is to be used to extent possible for lawn areas and is to be amended per the specifications to become the Planting Soil/Backfill Soil Mixture for use in planting pits and bed areas.

- C. Prior to use for lawn areas or in planting soil mix, Contractor shall remove all stones, roots, plants, sod, clods, and clay lumps larger than 1/2 –inch in any direction, pockets of coarse
- D. sand, concrete slurry, concrete layers or chunks, cement, plaster, building debris and other extraneous materials that are harmful to plant growth.
- E. After removal of debris and extraneous materials noted above, the Contractor shall obtain soil tests for the existing soil per the requirements in section 1.04 “Quality Assurance.”
- F. Contractor shall submit soil test results to the Project Officer for approval with confirmation by the Landscape Architect or Urban Forester.
- G. Contractor shall supplement the existing soil as recommended in soil test results to achieve a viable planting soil for lawns and/or planting beds. Contractor shall supplement with imported topsoil per the specifications from off-site sources when quantities of approved, existing topsoil are insufficient for lawns and planting beds.
- H. Contractor shall submit a sample of the topsoil that has been amended based on soil test results for approval by the Project Officer with confirmation by Landscape Architect or Urban Forester prior to use in lawn areas or planting beds or pits.
- I. Topsoil installed on grade shall attempt to match existing soil texture, except for situations where clay subsoil exists. In the event that clay subsoil exists, use loam or silt loam topsoil.
- J. Imported topsoil rather than existing topsoil is to be used for planting in bioretention areas, unless otherwise indicated on the approved plans.

2.04 PLANTING SOIL MIX/BACKFILL SOIL MIXTURE

- A. The planting soil mix (also known as backfill soil mixture) shall consist of existing topsoil that has been approved for planting per the specifications above and approved organic matter.
- B. The planting soil mix/backfill soil mixture shall be composed of $\frac{3}{4}$ approved existing topsoil and $\frac{1}{4}$ approved organic matter as described in the Arlington County DPR Standard planting details, unless otherwise indicated by the Project Officer with confirmation by the Landscape Architect or Urban Forester.

2.05 IMPORTED TOPSOIL

- A. Contractor shall add imported topsoil when required on the drawings, when quantity of existing topsoil is insufficient or when determined to be necessary due to soil testing results.

- B. Topsoil shall be the natural, original surface soil, a sandy loam uniform in composition and shall be in a friable condition and shall contain less than 3 percent subsoil, hardpan material, stones and clods larger than 1/2 inch in diameter in any direction. It shall also be free of sticks, tree or shrub roots, debris and other material undesirable for plant growth. The area and the topsoil shall be free of undesirable plant such as, but not limited to, Bermuda grass, nut sedge, mug wort or noxious weeds as set forth in the Federal Seed Act.
- C. The topsoil shall contain at least 5 percent organic matter. It shall be a sandy loam consisting of at least 5 but not more than 20% clay, at least 10 but not more than 80% sand. It shall have a pH between 5.5 to 6.5. Soluble salts (salinity) shall not exceed 500 ppm. Soil fertility shall be "High" in natural nutrients based on the coordinated ratings in pounds per acre as established by the National Soil and Fertilizer Research Committee.
- D. Topsoil which has been manufactured by blending materials which individually do not meet the requirements of this specification will not be accepted even though the resulting blend meets the organic matter, mechanical analysis, pH and soluble salts requirements. Agricultural limestone at not more than 5 pounds per cubic yard of topsoil any be used to adjust the pH provided it is well mixed in a manner which does not destroy the structure of the soil.

2.06 IMPORTED TOPSOIL FOR BIO-RETENTION AREAS

- A. If bioretention is specified in the approved plans, soil for bioretention areas shall comply with the Filter Media and Surface Cover section of the Virginia Department of Environmental Quality's (DEQ) Design Specification No. 9 for Bioretention, Version 2.0, January 1, 2013.

2.07 MULCHES AND ORGANIC MATTER

- A. Straw Mulch for Seeded Areas: Provide air-dry, clean, mildew and seed-free, salt hay or threshed straw of wheat, rye, oats or barley.
- B. Wood Chip Bark Mulch for Planted Areas: Wood Chip Bark Mulch shall be double-shredded hardwood bark mulch, uniform in size and free of stones, clods, non-organic debris or other foreign material and aged for at least 6 months from an approved source. Insufficiently or improperly aged mulch containing high bacterial counts or high levels of bark or other materials resistant to decomposition shall not be used. Mulch shall not contain the trunk of trees.
- C. Organic Matter/Compost Mulch: Well-composted, trash-free, stable, and weed-free organic matter such as composted bark, leaf mold or other plant debris material that has been composted to a point of decay and is mature.
 - a. pH ranges of 5.5 to 8; moisture content 35 to 55 percent by weight
 - b. 100 percent passing through 1-inch sieve

- c. Peat moss shall not be used.
- d. Organic amendments shall be commercially prepared and shall comply with the U.S. Compost Council Seal of Testing Assurance Program's Test Methods for the Examination of Composting and Compost (STA/TMECC) criteria, or as modified in approved plan documents.

2.08 SOIL STABILIZATION/EROSION CONTROL FABRIC

- A. ECS-2B Double New Straw Biodegradable Rolled Erosion Control Product, or an approved equal shall be used in all planting beds/reforestation areas.
 - a. Shall meet Type 2.D specifications for ECTC and HFWA FP-03 Section 713.17
 - b. Shall have two (2) layers of organic jute netting sewn together with biodegradable thread.
 - c. Overlap sections 12" and secure with manufacturer's recommended steel wire staples, 6 inches long.
- B. Erosion-Control Blankets: Biodegradable wood excelsior, straw, or coconut-fiber mat enclosed in a photodegradable plastic mesh. Include manufacturer's recommended steel wire staples, 6 inches long.
- C. Erosion-Control Fiber Mesh: Biodegradable burlap or spun-coir mesh, a minimum of 0.92 lb/sq. yd with 50 to 65 percent open area. Include manufacturer's recommended steel wire staples, 6 inches.
- D. Erosion-Control Mats: Cellular, non-biodegradable slope-stabilization mats designed to isolate and contain small areas of soil over steeply sloped grades, of 3 inches' nominal mat thickness. Include manufacturer's recommended anchorage system for slope conditions.
 - a. Products: Subject to compliance with requirements and plan documents, the products below, or an approved equivalent, be used:
 - i. Invisible Structures, Inc.; Slopetame 2
 - ii. Tenax Corporation – USA; Tenweb.

PART 3 - EXECUTION

3.01 PREPARATION

- A. All identified areas within the project limits shall have approved topsoil mix spread on them and be prepared for seeding and sodding by bringing ground surfaces to grades shown on the drawings. Planting pits and bed areas identified on the approved plans shall be prepared in accordance with the applicable DPR Landscape Standard details.
- a. No seeding shall be done on frozen ground or when the temperature is 32F or lower. Refer to specification 329200, "Seeding and Sodding." Install erosion-control measures to prevent erosion or displacement of soils and discharge of soil-bearing water runoff or airborne dust to adjacent properties, sidewalks and areas.
 - b. Rototilling shall not be performed within the critical root zone of trees to be preserved.
 - c. The soil shall not be tilled or amended when the soil's moisture capacity is above field capacity or when the soil is frozen.
 - d. Contractor shall identify utilities, existing irrigation and underground utilities. All areas on either side of the utility marking shall be amended by hand.
 - e. Contractor shall verify that no foreign or deleterious material or liquid has been deposited in soil within a planting area.
 - f. Contractor shall proceed with installation only after both unsatisfactory conditions have been corrected and rough grading has been completed and approved by the Project Officer in coordination with the Landscape Architect or Urban Forester.
 - g. Contractor shall protect structures, utilities, sidewalks, pavements and other facilities, trees, shrubs and plantings from damage caused by planting operations.
 - a. Protect adjacent and adjoining areas from hydro-seeding and hydro-mulching overspray.
 - b. Protect grade stakes set by others until directed to move them.
 - h. Surfaces shall conform to finish grade, free of water retaining depressions, soil friable, free of clay and of uniformly firm texture.
- B. Newly Graded Subgrades: Loosen subgrade to a minimum depth of 6 inches. Remove stones larger than 1/2 inch in any direction and sticks, roots, rubbish, and other extraneous matter including grass vegetation and turf and legally dispose of them off of Arlington County property. Do not mix into surface soil.

- a. Thoroughly blend planting soil mix off-site before spreading or spread topsoil, apply soil amendments and fertilizer on surface, and thoroughly blend planting soil mix. Delay mixing amendments with soil if planting will not proceed within 2 days.
 - b. Loosen surface soil to a depth of at least of 6 inches. Apply soil amendments and fertilizers according to planting soil mix proportions and mix thoroughly into top 4 inches of soil. Till soil to a homogeneous mixture of fine texture.
 - c. Spread planting soil mix to a depth of 4 inches but not less than required to meet finish grades after light rolling and natural settlement. Do not spread if planting soil or subgrade is frozen, muddy, or excessively wet.
- C. Unchanged Subgrades: If lawns are to be planted in areas unaltered or undisturbed by excavating, grading, or surface soil stripping operations, prepare surface soil as follows:
- a. Remove stones larger than 1/2 inch in any dimension and sticks, roots, trash, and other extraneous matter. Legally dispose them off of Arlington County property. Do not mix into surface soil
 - b. Loosen surface soil to a depth of at least 6 inches, apply soil amendments and fertilizers according to the planting soil mix proportion and mix thoroughly into the top 4 inches of soil.
- D. Finish Grading: Grade landscape areas to a smooth, uniform surface plane with loose, uniformly fine texture. Grade to within plus or minus 1/2 inch of finish elevation. Adjust for the thickness of sod, where applicable. Roll and rake, remove ridges, and fill depressions to meet finish grades. Limit fine grading to areas that can be planted in the immediate future.
- E. If bioretention areas are specified in the approved plans, the Contractor shall construct these areas in accordance with the Virginia DEQ Stormwater Design Specification No. 9, Version 2.0, January 1, 2013.
- F. Contractor shall avoid unnecessary compaction of the soil during grading.
- G. Contractor shall ensure appropriate slopes of the swales, berms and final grades.
- H. Immediately following each day's work, contractor shall clean all dirt, excess soil, debris and trash from the site. Contractor shall protect and store additional soils in stockpiles protected from saturation, erosion, weed growth and contamination with plastic sheeting or tarps.

- I. Amendments for seeding and sodding areas shall be applied after determining by soils test as follows:
 - a. Lime as specified shall be spread uniformly over designated area. Rate depends on soil tests. Soil tests shall be made before lime application at 8 to 10 plugs per acre taken by the method prescribed the United States Department of Agriculture.
 - b. Fertilizer shall be spread after the lime has been applied. Rate shall be as recommended per the soil tests.
 - c. Fertilizer shall be spread with approved equipment and at an even rate over the area to be seeded or sodded.
 - d. Work lime and fertilizer into top 4 inches of topsoil and grade to smooth surface ready for seeding.
- J. Restore areas if eroded or otherwise disturbed after finish grading and before planting.
- K. Prepared lawns and planting areas shall be inspected and approved by Project Officer in coordination with Landscape Architect prior to seeding, sodding or planting.
- L. If the graded areas develop volunteer weed growth, the growth shall be eliminated at the expense of the Contractor.

3.02 SOIL STABILIZATION MATERIALS

- A. Prepare planting area as specified.
- B. Moisten prepared planting area before planting if surface is dry. Water thoroughly and allow surface to dry before planting. Do not create muddy soil.
- C. Install Soil Stabilization from top of slope, overlapping joints by 12 inches, working downward, and as recommended by material manufacturer for site conditions. Fasten as recommended by material manufacturer.
- D. Plant shrubs, trees and perennials through Soil Stabilization fabric by carefully separating fabric layers to allow space for planting.
- E. Remove non-biodegradable stabilization materials after plant establishment.

A. PART 4 - MEASUREMENT AND PAYMENT

- 4.01** The measurement of PLANTING MIX to be paid for shall be per CUBIC YARD of planting mix in accordance with the plans, specifications and to the satisfaction of the Project Officer.
- 4.02** The unit price for PLANTING MIX shall include the cost of furnishing all labor, materials, equipment and incidental expenses, including but not limited to soil amendments, organic matter, and soil stabilization materials, necessary to complete the work, all in accordance with the plans, specifications and approval of the Project Officer.
- 4.03** The measurement of BIORETENTION SOIL MEDIA to be paid for shall be per CUBIC YARD of planting mix in accordance with the plans, specifications and to the satisfaction of the Project Officer.
- 4.04** If bioretention is explicitly called for in the approved plans, the unit price for BIORETENTION SOIL MEDIA shall include the cost of furnishing all labor, materials, equipment and incidental expenses, including but not limited to soil amendments, organic matter, and soil stabilization materials, necessary to complete the work, all in accordance with the plans, specifications and approval of the Project Officer.
- 4.05** The measurement of WOOD MULCH to be paid for shall be per CUBIC YARD of Mulch in accordance with the plans, specifications and to the satisfaction of the Project Officer.
- 4.06** The unit price for WOOD MULCH shall include the cost of furnishing all labor, materials, equipment and incidental expenses necessary to complete the work, all in accordance with the plans, specifications and approval of the Project Officer. Does not include excavation.

PART 1 - GENERAL**1.03 SUMMARY**

- A. The work includes, but is not limited to the provision of all material, services, labor, and equipment necessary to perform the following as required per the plans for the establishment of turf, meadow grasses and/or wildflowers:
 - a. Seeding
 - b. Sodding
 - c. Hydro-seeding
 - d. Plugging

- B. Related Sections:
 - a. Section 02200 – Earthwork
 - b. Section 329100 – Planting Preparation
 - c. Section 311300 – Tree Protection and Root Pruning
 - d. Section 329300 – Exterior Plants
 - e. Section 01500 – Erosion and Sediment Control and Pollution Prevention

- C. In addition to the specifications contained herein, Work shall be performed in accordance with the:
 - a. Drawings and general provisions of the contract, including general and supplementary conditions.
 - b. Arlington County Department of Parks & Recreation (DPR) Design Standards as shown on the plans and available online at:

<http://parks.arlingtonva.us/design-standards/>

1.02 DEFINITIONS

- A. Finish Grade: Elevation of finished surface of planting soil.

- B. Imported Topsoil: Soil obtained off-site that meets the specifications herein for topsoil and is suitable for use in planting soil/backfill soil mixture when existing soil quantities are insufficient. Refer to Section 329100 “Planting Preparation.”

- C. Planting Soil/Backfill Soil Mixture: Existing soil modified as specified to be suitable for planting. Refer to Section 329100 “Planting Preparation.”

- D. Subgrade: Surface or elevation of subsoil remaining after completing excavation, or top surface of a fill or backfill, before placing planting soil.

- E. ISA: International Society of Arboriculture
- F. CBAY: Chesapeake Bay, typically referring to CBAY watershed.
- G. Urban Forester/County Urban Forester: Refers to the Arlington County Urban Forester
- H. Landscape Architect: Refers to an Arlington County Landscape Architect or their designee.

1.03 SUBMITTALS

- B. Samples of all materials shall be submitted to the Project Officer for approval with confirmation by the County Landscape Architect prior to delivery to site.
- C. Contractor shall submit qualifications per section 1.04 "Quality Assurance" to Project Officer for approval.
- C. Samples:
 - a. Seed Mix: Certification of grass seed including the botanical and common name, percentage by weight of each species and variety, and percentage of purity, germination, and weed seed. Include the year of production and the date of packaging.
 - b. Sod: Sod grower's name, together with substantiating information as to field location from which sod is to be cut and species, percent purity and mixture of grass sod to be applied. Samples or photos of sod mix may be requested in lieu of inspection.
 - c. Special Seed Mixes: Contractor shall submit product data per section 2.03.

1.04 QUALITY ASSURANCE

- A. Contractor qualifications:
 - a. Evidence of completion of at least three (3) projects of similar nature and scope to this project completed within the last five (5) years that have resulted in successful turf and meadow establishment
 - b. Contractor shall be a member in good standing of either the Professional Land care Network or the American Nursery and Landscape Association.
 - c. Experience: Three to Five years' experience in turf installation.

- B. Contractor shall maintain an experienced full-time supervisor on Project site when work is in progress.

PART 2 - PRODUCTS

2.01 MATERIALS

- A. All materials shall conform to those stipulated below, unless otherwise approved in writing by the Project Officer with confirmation by the Landscape Architect.
- B. Specified materials to be applied in amounts and methods herein stipulated.
- C. Delivery tickets indicating date, weight, product data including all analyses for purity and other information as required herein, and vendor's name, to be submitted to Project Officer for approval.

2.02 SEED

- A. Grass seed shall be fresh, clean, dry new crop seed complying with purity and germination requirements stipulated herein. All cultivars must be on the current "Virginia Turfgrass Variety Recommendations" or in the top 25 for transitional zone sites-overall of the latest National Turf Grass Evaluation Program (NTEP) as approved by Project Officer with confirmation by the Landscape Architect. The Turf-type Tall Fescue component shall be comprised of a minimum of two cultivars with each cultivar comprising neither less than 30 percent nor more than 70 percent of the blend. The use of K-31 Tall Fescue or Common Kentucky Bluegrass in the mix is prohibited. The mix shall have 2.5 percent maximum inert matter, 0.5 percent maximum crop seed, and 0.1 percent maximum weed seed and 0.0 percent noxious weed. The mix shall comply with the current Virginia Seed Law and Virginia Seed Regulations and approximate the following:

<u>Kind of Seed</u>	<u>% by Weight</u>	<u>% Purity</u>	<u>% Germination</u>
Turf-type Tall Fescue	80	97	85
Bluegrass	10	97	80
Perennial Ryegrass	10	97	90

- B. Substitution of seed type or percent only on approval of Project Officer in coordination with Landscape Architect. Seed to be free of noxious weed seed.

2.03 SOD

Cultivated Grass Sod shall be certified and obtained from State Certified nurseries and have been grown on natural native mineral soils comparable to those afforded at the job site. Sod containing netting is not acceptable. Sod grower's information and sod information to be submitted for approval by Project Officer per section 1.03 "Submittals." Failure to obtain advance approval will constitute grounds for rejection of all sod delivered to the site. Invoices for all sod to clearly state point of origin and have attached to them a facsimile of the Grower's Nursery Certificate issued by the U.S. Department of Agriculture or Certified Delivery Ticket per truckload. All grass sod shall meet the following basic requirements.

- a. Sod shall be free of disease and soil borne insects.
- b. Sod shall be free of clover, broadleaf weeds and noxious weeds. Sod considered free of such weeds if less than 2 such plants are found per 100 square feet of area.
- c. Sod shall be of uniform color and density and contain:

Kind of Seed	% by Weight
Turf Type Tall Fescue	90
Kentucky Bluegrass	10
- d. All cultivars must be on the current approved list of the Virginia Turfgrass Variety Recommendations and the sod shall be certified by the Virginia Sod Certification Program. Provide appropriate certifications at the time of installation.
- e. Sod sample shall be submitted to and approved by Project Officer in coordination with the Landscape Architect before cutting. Sod placed on the job shall conform to the approved sample or shall be removed and replaced at the Contractor's expense.
- f. Sod shall have been mowed prior to stripping and shall have been maintained for a minimum of three months.
- g. Sod shall be relatively free of thatch. Thatch build up that significantly detracts from the appearance of the sod may be sufficient cause for rejection.

- h. Sod shall be machine stripped at a uniform soil thickness of approximately ¾-inch. Measurement for thickness to exclude tip growth and thatch.
- i. Individual pieces of sod shall be cut to supplier's standard width and length. Maximum allowable deviation from standard widths and lengths shall be 5%. Broken pads, torn or uneven ends shall not be permitted.
- j. Root development shall be such that standard size pieces will support their own weight and retain their size and shape when suspended vertically from a firm grasp on uppermost 10% of the area.
- k. Under moderate moisture conditions, weight shall not exceed 7 pounds per square foot. Minimum weight shall not be less than 4 lbs. per square foot.

2.04 SPECIALTY SEED (WILFLOWERS, BIORETENTION, and/or REFORESTATION)

- A. When specialty seed is explicitly specified in approved plans, and unless otherwise indicated, the specialty seed mix shall be as follows:

Seed and straw with the following seed mix at the specified application rate.
Seed should be applied to roughened soil (soil surface broken up) via broadcast seeding.

Provided mixes include annual rye for immediate/short term stabilization. Winter wheat (*Triticum aestivum*) should be substituted for the annual rye between November 1 and February 15.

- a. Riparian Buffer Mix

Application rate 50 lbs/acre

- 20% Annual rye – *Lolium multiflorum*
- 30% Virginia wild rye – *Elymus virginicus*
- 25% Deer-tongue grass – *Panicum clandestinum*
- 15% Riverbank wild rye – *Elymus riparius*
- 5% Bottle-brush grass – *Elymus hystrix*
- 2% Partridge pea – *Chamaecrista fasciculata*
- 1% Rough-stemmed goldenrod – *Solidago rugosa*
- 1% Common milkweed – *Asclepias syriaca*
- 1% Grass-leaved goldenrod – *Euthamia graminifolia*

- b. Floodplain Mix

Application rate: 35 lbs/acre

Scientific Name	Common Name	Percent of Mix
<i>Lolium perenne</i>	Annual Ryegrass	29
<i>Dichanthelium clandestinum</i>	Deertongue Grass	14
<i>Polygonum pensylvanicum</i>	Pennsylvania Smartweed	14
<i>Elymus virginicus</i>	Virginia Wild Rye	9
<i>Juncus effusus</i>	Soft Rush	9

Polygonum virginianum	Jumpseed	6
Agrostis perennans	Autumn Bentgrass	3
Eupatorium fistulosum	Hollow Joe-pye-weed	3
Eupatorium hyssopifolium	Hyssop-leaved Thoroughwort	3
Glyceria striata	Fowl Manna Grass	3
Helianthus decapetalus	Thin-leaved Sunflower	3
Scirpus cyperinus	Woolgrass	3
Tripsacum dactyloides	Eastern Gamagrass	3

c. Upland Mix

Application Rate: 50 lbs/acre

Scientific Name	Common Name	Percent of Mix
Lolium perenne	Annual Ryegrass	24
Agrostis perennans	Autumn Bentgrass	20
Sorghastrum nutans	Indian Grass	20
Schizachyrium scoparius	Little Bluestem	16
Dichanthelium clandestinum	Deertongue Grass	10
Rudbeckia hirta	Black-eyed Susan	6
Aster divaricatis	White wood aster	4

d. Seed carrier: Inert material, sharp clean sand mixed with seed at a ratio of not less than two parts seed carrier to one-part seed.

B. Contractor shall supply the germination test results and the percent purity of the seeds upon delivery to the site to the Project Officer. All seed shall be cleaned, processed, analyzed for purity, stored, and germination tested before being used. Every seed variety contains different germination rates and requirements.

C. Execution:

a. Sow seed with spreader or seeding machine. Do not broadcast or drop seed when wind velocity exceeds 5 mph. Evenly distribute seed by sowing equal quantities in two directions at right angles to each other.

b. Brush seed into top 1/8 inch of soil, roll lightly and water with light spray.

c. Protect seeded areas by applying compost mulch within 24 hours after completing seeding operations. Soak areas, scatter mulch uniformly to a thickness of 3/16 inch and roll surface smooth.

d. Water newly planted areas and keep moist until established.

2.05 SOILS & SOIL AMENDMENTS

A. Refer to Section 329100 "Plant Preparation" soils and soil amendment specifications.

2.06 MULCHES/ ORGANIC MATTER

A. Refer to Section 329100 "Plant Preparation" for mulch specifications.

2.07 SOIL STABILIZATION/EROSION CONTROL FABRIC

- A. Refer to Section 329100 "Plant Preparation" for specifications.

PART 3 - EXECUTION

3.01 PREPARATION

- A. Refer to Section 329100 "Plant Preparation" for specifications.

3.02 SEEDING - GRASS

- A. All areas within the project limits that are not shown for paving, sodding, or special treatment shall be seeded with the specified seed mix.
- B. Seeding shall take place between August 15th and October 15th or between March 15th to May 15th. Approval from Project Officer/Landscape Architect will be required before seeding is to begin.
- C. Use 4" of prepared topsoil as base for areas to be seeded.
- D. No seeding shall be done during windy weather (winds over 5 mph) or when ground is wet or otherwise non-tillable. No seed shall be done on frozen ground or when the temperature is 32 or lower.
- E. Seed shall be uniformly distributed by hydro-seeding methods as specified:
 - a. Slurry
 - i. Seed as specified at a rate of 350 lbs./acre.
 - ii. Mulch: virgin wood fiber type applied at a rate of 1200 lbs./acre.
 - iii. Tackifier: Guar type or approved equal applied at a rate of 40 lbs./acre.
 - iv. Fertilizer: 19-19-19 granular applied at a rate of 500 lbs./acre.
 - v. Lime: Flowable liquid lime at a rate of 5 gallons per acre.
 - vi. Dye: Slurry must be green with dye added if not included with the mulch.
 - vii. Application rate: 3000 gallons per acre. Agitation must be maintained throughout mixing and application.
 - viii. Slurry shall be applied within 8 hours of the start of mixing.
 - ix. In lieu of hydro-seeding, seed may be drilled or an alternate method may be used. If an alternate method is used, seeding will have to be run in two directions. The second direction being at right angles to the first direction. Requests for using alternate methods shall be approved by the Project Officer prior to application of seed.
 - x. Sow seed at the rate of 5 to 8 lb/1000 sq. ft.

- xi. Rake seed lightly into top 1/8 inch of topsoil, roll lightly, and water with fine spray.
- xii. Protect seeded areas with slopes not exceeding 6:1 by spreading straw mulch. Spread uniformly at a minimum rate of 2 tons/acre to form a continuous blanket 1-1/2 inches in loose depth over seeded areas. Spread by hand, blower, or other suitable equipment.
- xiii. Areas indicated on plan or exceeding 6:1 slope shall be protected with erosion control fabric, jute mat, or similar slope protection, installed according to manufacturer's written instruction, and/or as approved by the Project Officer.

3.03 SODDING

- A. All sod shall be transplanted within 24 hours from the time it is harvested unless stacked at its destination in a manner satisfactory to the Project Officer. Do not lay down if dormant or if the ground is frozen or muddy.
- B. All sod in stacks shall be kept moist and protected from exposure to air and sun and from freezing. Any sod permitted to dry out may be rejected whenever, in judgment of Project Officer, its survival after placing is doubtful. No payment shall be made for rejected sod. In any event, no more than forty-eight hours shall lapse between cutting and planting of sod is permitted.
- C. Before placing or depositing sod upon any surfaces, all shaping and redressing of such surfaces as described under Seeding Soil Preparation shall be completed. The bed area for sod shall be dug out so that when the sod is installed the adjacent soil will be flush with the top of the sod root mat. Areas shall be watered lightly before the placing of sod; sod shall not be placed on dry surfaces. Completed areas to be sodded shall be a smooth, uniform, well-tilled surface true to line and cross section. Any raking required shall be done immediately prior to placement of the sod at no additional cost to Owner.
- D. No sod shall be placed at any time temperature is below 32 degrees Fahrenheit. No frozen sod shall be used and no sod shall be placed upon frozen, powder dry or excessively wet soil.
- E. Use 4" of prepared topsoil as base for areas to be sodded.
- F. Sod shall be lifted from trucks or storage piles by hand and placed with closed joints and no overlapping. All cracks, seams and voids shall be closed with small pieces of sod. After laying sod shall be sprinkled thoroughly and then tamped. "Tamping" consists of firmly

closing seams between strips by use of hand tampers or approved rollers. All sod shall be thoroughly rolled after closing all seams. Correct any slipping of sod.

- G. Adequate water and watering equipment must be on hand before sodding begins and sod shall be kept moist until root system adheres to original seed bed and becomes established and accepted by Project Officer.
- H. Sod shall be laid with long edges parallel to contours, except in swales or ditches where it shall be placed perpendicular to the flow line. Only sod placed in swales or ditches shall be staked using 2 stakes per roll of sod. Stakes shall be wood wedges ½" x 1" x 12". Successive strips to be neatly matched and all joints staggered. Sod will be laid in all areas indicated on landscape plans.

3.04 RE-FORESTATION

- A. Prepare planting area per the specifications.
- B. Reforestation process:
 - a. Reforestation seed mix shall be applied prior to installation of Erosion Control Fabric. Rake seed lightly into the top 1/8 inch of soil, roll lightly and water with fine spray.
 - i. Do not use wet seed or seed that is moldy or otherwise damaged.
 - ii. Do not seed against existing trees or vegetation to remain within reforested area limits.
 - iii. Top dress seed by applying composted mulch within 24 hours after seeding operation. Soak areas, scatter mulch uniformly to a thickness of 1/2 inch and roll surface smooth.
 - b. Install erosion control fabric from top of slope, overlapping joints by 12 inches, working downward, and as recommended by material manufacturer for site conditions. Fasten as recommended by material manufacturer.
 - c. Moisten prepared planting area before planting if surface is dry. Water thoroughly and allow surface to dry before planting. Do not create muddy soil.
 - d. Plant shrubs, trees and perennials through erosion control fabric by carefully separating fabric layers to allow space for planting.
- C. Remove non-degradable erosion-control measures after grass establishment period.

3.05 PROTECTION

- A. Install post and rope barriers around seeded areas. Tie cloth or ribbon to rope at 10' intervals.
- B. Install "KEEP OFF LAWN" signs at appropriate locations.
- C. Remove non-biodegradable erosion control measures after plant establishment period.

3.06 MAINTENANCE

- A. Maintain surfaces and supply additional topsoil where necessary, including areas affected by erosion.
- B. Water to ensure uniform seed germination and to keep surface of soil damp:
 - a. Each watering shall consist of 1 gallon per 3 sq. yd. of seed or sod
 - b. Apply water slowly so that surface of soil will not puddle and crust
- C. Cut lawn areas when grass reached height of 3". Maintain minimum height of 2". Do not cut more than 1/3 of blade at any one mowing.
- D. After first mowing of lawn, water grass sufficiently to moisten soil from 3" to 5" deep.
- E. Reseed damaged grass areas showing root growth failure, deterioration, bare or thin spots and erosion.

3.07 GUARANTEE

- A. The Contractor shall be responsible for maintaining all sodded and seeded areas in a healthy, vigorous condition in accordance with Section 3.05 "Maintenance" at his/her own expense until all contracted work is completed and accepted by Project Officer with confirmation by the Landscape Architect or Urban Forester.
- B. The Contractor shall, at his own expense, replace any seed or sod which has died or been damaged during the establishment period.
- C. Cost of seed and sod will be withheld from final payment until final approval is given by Project Officer.

3.08 ACCEPTANCE

- A. Seeded areas will be accepted when an even, healthy, close and uniform stand of turf, 3” tall, free of weeds and surface irregularities, with coverage exceeding 90 percent over any 10sq. ft. and bare spots not exceeding 4 by 4 inches is properly established. Bare spots in excess of 4” shall be re-seeded at a rate per section 3.02 of this specification.
- B. Sodded areas shall be accepted provided all requirements, including maintenance, have been complied with and sod is well established in a healthy, vigorous growing condition. Reestablish lawns that do not comply with requirements and continue maintenance until lawns are satisfactory.
- C. Upon completion, all debris and waste material resulting from seeding/sodding/mulching activities shall be removed from the project area and legally disposed of. Any damaged areas shall be restored to their original condition.
- D. Upon acceptance by Project Officer at Final Completion, Arlington County shall assume all lawn maintenance responsibilities.

PART 4 - MEASUREMENT AND PAYMENT

- 4.01** The measurement of SEEDING to be paid for shall be per SQUARE YARD of seeded grass in accordance with the approved plans and specifications.
- 4.02** The unit price for SEEDING shall include the cost of furnishing all labor, materials, equipment and incidental expenses necessary to complete the work, including but not limited to erosion control, topsoil, mulch, protection and maintenance, all in accordance with the approved plans and specifications.
- 4.03** The measurement of SPECIALTY SEEDING to be paid for shall be per SQUARE YARD of reforestation seed mix in accordance with the approved plans and specifications.
- 4.04** The unit price for SPECIALTY SEEDING shall include the cost of furnishing all labor, materials, equipment and incidental expenses necessary to complete the work, including but not limited to erosion control, topsoil, mulch, protection and maintenance, all in accordance with the approved plans and specifications.
- 4.05** The measurement of SOD to be paid for shall be per SQUARE YARD of sod installed in accordance with the approved plans and specifications.

- 4.06** The unit price for SOD shall include the cost of furnishing all labor, materials, equipment and incidental expenses necessary to complete the work, including but not limited to erosion control, protection and maintenance, all in accordance with the approved plans and specifications.

1.01 SUMMARY

PRODUCT DATA SHEET 4 - This Section includes trees, shrubs, groundcover, bulbs, and perennial plants.

PRODUCT DATA SHEET 5 - Provide all labor, materials, tools and equipment as required to have plants, topsoil, amendments, mulch and seed and/or sod applied on all areas called for on the approved plans.

PRODUCT DATA SHEET 6 - Related Sections:

- a. 02200 Earthwork
- b. 329100 Planting Preparation
- c. 311300 Tree Protection and Root Pruning
- d. 01500 Erosion and Sediment Control and Pollution Prevention
- e. 329200 Seeding and Sodding

PRODUCT DATA SHEET 7 - In addition to the specifications contained herein, Work shall be performed in accordance with the:

- a. Drawings and general provisions of the contract, including general and supplementary conditions
- b. Arlington County Department of Parks & Recreation Design Standards as shown on the plans and available online at:

<http://parks.arlingtonva.us/design-standards/>

1.02 DEFINITIONS

- A. Finish Grade: Elevation of finished surface of planting soil.
- B. Imported Topsoil: Soil obtained off-site that meets the specifications herein for topsoil and is suitable for use in planting soil/backfill soil mixture when existing soil quantities are insufficient. Refer to Section 329100 "Planting Preparation."
- C. Planting Soil/Backfill Soil Mixture: Existing soil modified as specified to be suitable for planting. Refer to Section 329100 "Planting Preparation."
- D. Subgrade: Surface or elevation of subsoil remaining after completing excavation, or top surface of a fill or backfill, before placing planting soil.

- E. ISA: International Society of Arboriculture
- F. CBAY: Chesapeake Bay, typically referring to CBAY watershed.
- G. Urban Forester/County Urban Forester: Refers to the Arlington County Urban Forester
- H. Landscape Architect: Refers to an Arlington County Landscape Architect or their designee.

1.03 SUBMITTALS

- A. All submittals specified in Section 329100 "Planting Preparation" shall be provided to Project Officer for approval with confirmation by Landscape Architect or Urban Forester. All approvals shall be in writing.
- B. Product Certificates: Contractor shall submit for each type of manufactured product, to be approved by the Project Officer and complying with the following:
 - a. Manufacturer's certified analysis for standard products.
- C. Refer to Section 329100, "Planting Preparation" for soil test requirements.
- D. Contractor shall submit State Nursery inspection certificates to the Project Officer.
- E. Contractor shall submit to Project Officer the verification of Landscape Industry Certified Technician and Landscape Industry Certified Officer certificates for those responsible for plant installation.
- F. Planting Schedule: Contractor shall submit the planting schedule to the Project Officer for approval with confirmation by the Landscape Architect or Urban Forester. The plant schedule will indicate anticipated planting dates for exterior plants. Contractor shall be responsible for furnishing and installing all plant material shown on the drawings and plant list, as submitted with the contract. Contractor shall have investigated the sources of supply and satisfied himself/herself that he/she can supply all of the plants specified on the drawings in the size, variety, quantity and quality noted before submitting the bid. Failure to take this precaution will not relieve the successful bidder from the responsibility of furnishing and installing all of the plant material in strict accordance with the contract documents.
- G. Substitutions:

- a. The Contractor shall submit a written request for a substitute plant a minimum of forty-five (45) calendar days prior to planting date if specific plants will not be available in time for the scheduled planting. Contractor shall submit the request to the Project Officer for approval with confirmation by the Landscape Architect or Urban Forester.
 - b. Contractor shall be responsible for documenting any plant suitability or availability problems.
 - c. If a substitute plant is offered to the County, it shall be of the same size, value and quality as the plant originally specified on the plan, as determined by the Project Officer in coordination with the Landscape Architect or Urban Forester. If the County does not accept the substitute plant, the Contractor shall provide the type and size of plant material specified on the plans, or a substitute requested by the Project Officer in coordination with the Landscape Architect or Urban Forester.
- H. Maintenance Instructions: Contractor shall submit to the Project Officer recommended procedures for maintenance of exterior plants during a calendar year. Submit before end of required maintenance periods.

1.04 QUALITY ASSURANCE

- A. Installer Qualifications:
 - a. Contractor shall designate a project crew leader who possesses one or more of the following certifications:
 - i. Certified by the Professional Land Care Network (PLANET) as a “Landscape Industry Certified Technician”
 - ii. Certified by the Professional Land Care Network (PLANET) as a “Landscape Industry Certified Officer”
 - b. The Contractor shall identify to the Project Officer at least one full-time on-site supervisor who is the Contractor’s competent, qualified, and authorized person on the worksite and who is, by training or experience, familiar with the policies, regulations and standards applicable to the work being performed, and capable of sufficiently communicating with the Project Officer.
 - c. Crew leader and supervisor may be the same individual.
- B. Installer Qualifications for Reforestation Projects (required only if approved plans specify reforestation, afforestation or streambank restoration):

- a. ISA Certified Arborist shall be on the worksite during planting of reforested areas.
 - b. Demonstrate experience in Reforestation/Afforestation and Stream-Bank Stabilization projects through:
 - i. Project portfolio detailing a minimum of three (3) successfully completed reforestation/afforestation/streambank restoration projects in the CBAY watershed area over the past three years.
 - c. The County will, throughout the contract term, have the right of reasonable rejection and approval of staff or subcontractors assigned to the project by the Contractor. If the County reasonably rejects staff or subcontractors, the Contractor shall provide replacement staff or subcontractors satisfactory to the County in a timely manner and at no additional cost to the County. The day-to-day supervision and control of the Contractor's employees, and any employees of any of its subcontractors, shall be solely the responsibility of the Contractor.
- C. Topsoil Analysis: Furnish soil analysis by a qualified soil-testing laboratory. Comply with requirements in Section 329100, "Planting Preparation."
- D. Provide quality, size, genus, species, and variety of exterior plants indicated, complying with applicable requirements in the most current version of ANSI Z60.1, "American Standard for Nursery Stock." Plants shall be nursery grown stock and conform to the requirements described in the most current issue of the American Standard for Nursery Stock (ANSI) published by the American Nursery and Landscape Association. The Project Officer with confirmation by the Landscape Architect or Urban Forester may reject any non-conforming stock and has the option to field-select plant materials prior to purchasing.
- E. Collected material may be used only when approved by Project Officer with confirmation by Arlington County Urban Forester and/or DPR PNR Natural Resource Manager
- F. Nomenclature shall be in accordance with *Hortus III*, by L.H. Bailey. All trees and shrubs shall be labeled with a securely attached, waterproof tag bearing legible designation of botanical and common name. Perennials and groundcovers shall be clearly identified with a waterproof tag bearing legible designation of botanical and common name within the container.
- G. Pre-installation Conference: Conduct conference at Project site with Project Officer, Arlington County Urban Forester and/or Department of Parks and Recreation (DPR) representative or County Landscape Architect.

- H. Urban Forester Notification: Notify the Project Officer at least 72 hours prior to commencement of tree planting operations, so that the County's Urban Forester can be present on-site to observe the work.
- I. The Contractor shall provide a minimum of seven (7) business days' notice to the Project Officer prior to installing the plant material (this is not the same as inspection notification).
- J. At the request of the Project Officer in coordination with the Urban Forester or Landscape Architect, the Contractor shall supply information specifying the provenance of the plant material. Provenance is the geographical origin of the seed or cutting used in propagation and can have a direct effect on plant vigor and survivability.
- K. Inspections:
 - a. Urban Forester may perform periodic inspections to check on tree plantings.
 - b. Contractor shall arrange a meeting on site with the Project Officer in coordination with the Urban Forester and/or Landscape Architect to perform final inspection of plantings. Refer to section 1.07 "Final Inspection."

1.05 WORKMANSHIP

- B. **Any tree pruning shall conform to the most current version of ANSI A-300 Standard Practices for Trees, Shrubs, and Other Woody Plant Maintenance. Do not prune trees and shrubs before delivery.**
- C. Protect bark, branches, and root systems from sun-scald, drying, sweating, whipping, and other handling and tying damage. Do not bend or bind-tie trees or shrubs in such a manner as to destroy their natural shape. Provide protective covering of exterior plants during delivery. Do not drop exterior plants during delivery. Plants shall not be bound with wire or rope at any time so as to damage the bark or break branches. Plants shall be handled from the bottom of the root ball only.
- D. All plants in transit shall be tarped or covered and shall be kept from drying out. Desiccation damage shall be cause for rejection. Plants damaged in handling or transportation may be rejected by the Project Officer with confirmation by the Urban Forester/Landscape Architect. Any tree or shrub found to have wounds over 12.5% of the circumference of any limb or trunk, or over 1 inch in any direction, whichever is smaller, shall be rejected.

- E. Deliver exterior plants after preparations for planting have been completed and install immediately. If planting is delayed more than six hours after delivery, set exterior plants trees in shade, protect from weather and mechanical damage, and keep roots moist. Plants shall not remain unplanted for longer than a three-day period after delivery. Any plants not installed during this time period shall be rejected, unless Project Officer and contractor provide otherwise by written agreement. All plants kept on site for any period of time shall be watered and cared for using ANSI A300 standards.
- F. Plants shall be installed immediately following excavation of the hole. No holes shall remain open overnight. The Contractor shall cover and barricade any open holes to effectively prevent any danger of injury to pedestrians.
- G. During delivery and installation, the landscape contractor shall perform in a professional manner, coordinating his/her activities so as not to interfere with the work of other trades, and leaving his/her work area(s) clean of litter and debris at the close of each workday.
- H. During planting, all areas shall be kept neat and clean, and precautions shall be taken to avoid damage to existing plants, trees, turf and structures. Where existing trees are to be preserved, additional precautions shall be taken to avoid unnecessary accumulation of excavated materials, soil compaction, or root damage. The Contractor shall cover sidewalks or pavers with plywood, and cover turf with plywood, burlap or tarp during excavation.
- I. Any damaged areas caused by the Contractor shall be restored to their original condition at no cost to the County. All debris and waste material, including small stones and clumps of clay or dirt exceeding 1" by 1" in any direction, resulting from planting operations shall be removed from the project, **legally disposed**, and the area cleaned up by the Contractor.
- J. Plants with soil covering the root flare, if not removed by Contractor, shall be rejected by Project Officer with confirmation by Landscape Architect or Urban Forester.
- K. Contractor shall take full responsibility for any cost incurred due to damage of utilities by their operations.
- L. The Contractor will not be held responsible for uncommon concealed conditions such as concrete/asphalt/stone spoils encountered in excavation work which are not apparent at the time of bidding. Rocks, tree roots and hard clay are common elements of "urban" soils and will frequently be encountered in the execution of the contract.

- M. No plants shall be planted in locations where drainage may, in the opinion of the Contractor, be unacceptable. Such situations shall be brought to the attention of the Project Officer before work continues and, if deemed necessary by the Project Officer with confirmation by the Landscape Architect/Urban Forester, the plants shall be relocated or the contract shall be modified to allow for drainage correction at a negotiated cost. Any such modification shall be in writing and signed by both parties.
- N. The Contractor shall layout plants according to the project's landscape plan. The Project Officer shall approve the layout with confirmation by the Landscape Architect prior to plant installation. Plants installed without layout approval from the Project Officer with confirmation by Landscape Architect are subject to removal and replanting by the Contractor at no additional cost to Arlington County.

1.06 WATER REQUIREMENTS

- A. Initial Watering: The Contractor shall supply water for all plantings and shall water all plants at time of installation and 48 hours after installation, even if it is raining. Contractor shall then water plantings at least twice per week at amounts specified below until final acceptance of work.
- B. Each watering shall consist of:
 - a. 20 gallons per individual tree
 - b. 4 gallons per individual shrub
 - c. 1 gallon per 1 sq. yd. of shrub or perennial bed
 - d. 1 gallon per 3 sq. yd. of seed or sod
- C. Once final acceptance is completed, Contractor shall have no obligation to water all plantings and the one (1) year planting warranty

1.07 FINAL INSPECTION

- A. Contractor shall schedule the final inspection with the Project Officer in coordination with the Urban Forester and/or Landscape Architect.
 - a. Contractor shall notify Project Officer at least one week in advance to arrange final inspection meeting with the Urban Forester and/or Landscape Architect.

- b. Contractor shall conduct the final inspection of the landscape materials no less than three months after the installation of the plants or substantial completion of construction work, whichever comes last, and in the presence of the Project Officer, the Urban Forester and/or Landscape Architect.
- c. The landscaping inspection will review all landscape work under the contract.
- d. All plants shall be alive and in good health at the time of final inspection.
- e. Any plant material that is 25% dead or more shall be considered dead and shall be replaced at no charge to the County. A tree shall be considered dead when the main leader has died back, or 25% of the crown is dead.
- f. It shall be the Contractor's responsibility to provide in writing the results of this inspection.
- g. The Contractor shall make replacements during the next planting period unless the County specifies an earlier date.
- h. The replacement plants will be reviewed for final acceptance no less than three months after installation. Contractor is responsible for maintenance and watering of replacement material per Section 1.06 and Section 1.08 after planting and until the replacement plantings are finally accepted by Project Officer.
- i. A replacement plant shall be of the same size as the original plant with no additional soil additives to be used.
- j. The Contractor will not be responsible for plants that have been damaged by vandalism, fire, removal or other activities beyond the control of the Contractor.

1.08 MAINTENANCE

- A. Trees, Shrubs, Perennials, Bulbs & Groundcovers: Contractor shall maintain plantings at his/her own expense until final acceptance of the plantings as specified herein section 1.07.
- B. Maintenance shall include pruning, mulching, cultivating, watering, weeding, fertilizing, tightening and repairing stakes and guy supports, and resetting to proper grades or vertical position, as required to establish healthy, viable plantings.

- C. Pruning: Remove all sucker growth, dead or broken branches at initial planting and as needed during the warranty period. Pruning will conform to ANSI-300 Tree Pruning Standards.
- D. Fertilizing: No plants shall be fertilized without prior approval of Project Officer with confirmation by the Urban Forester or Landscape Architect.
- E. Mulching: Contractor shall re-mulch areas to a depth of two to three inches prior to final acceptance if the time between planting and final acceptance extends beyond six months. Mulch will be of the same quality as mulch provided at the time of planting. Keep mulch six-inches away from trunks of trees and shrubs.
- F. Weeding: Contractor shall perform weeding until final acceptance to keep the planting area as free of weeds as possible. A minimum of one weeding per month from April through October is required if time between planting and final acceptance extends through any months of the growing season.
- G. Stakes and Guy Supports: If installed, Contractor shall monitor and adjust all stakes and guy supports until final acceptance.

PART 3 - PRODUCTS**2.01 EXTERIOR PLANTS**

PRODUCT DATA SHEET 0 - Contractor shall select plants only from nurseries that have been inspected by state or federal agencies and shall have been grown in USDA Plant Hardiness Zones 4, 5, 6, or 7, and in one of the following states: Maryland, Virginia, Delaware, New Jersey, North Carolina or Pennsylvania.

PRODUCT DATA SHEET 1 - Tree and Shrub Material: Furnish nursery-grown trees and shrubs complying with ANSI Z60.1, with healthy root systems developed by transplanting or root pruning. Provide well-shaped, fully branched, healthy, vigorous stock free of disease, insects, eggs, larvae, and defects such as knots, sun-scald, injuries, abrasions, and disfigurement.

1. Provide balled and burlapped, bare root or container-grown trees and shrubs, as indicated on the Drawings.
2. Balled and Burlapped (B&B) plants shall be dug with firm root balls of earth and free of noxious weeds. There shall be no extra soil on top of the root ball or around the trunk. Balled and burlapped trees shall be securely held in place by untreated burlap and stout rope. Nylon rope is NOT acceptable. Loose, broken or manufactured balls are unacceptable.

3. Ball sizes shall be in accordance with current ANSI standards.
4. In size-grading B&B single stem trees, caliper shall take precedence over height. For multiple-trunk trees, height measurement shall take precedence over caliper.
5. Trees over 1" in caliper shall have a strong central leader (free and clear of branches or splits in the trunk) from the top of the root ball to a height of at least 6'-6". Only minimal bends in the trunk will be acceptable. Co-dominant stems and V-crotches shall be cause for rejection.
6. The root system of container-grown plants shall be well developed and well distributed throughout the container.
7. All container-grown trees and shrubs that have circling and matted roots shall be rejected.

PRODUCT DATA SHEET 2 - Perennials: Provide healthy, container-grown plants with well-developed, fibrous root systems from a commercial nursery, of species and variety shown in the Drawings. All container grown plants shall be healthy, vigorous, well rooted and established in the container in which they are growing. A container grown plant shall have a well-established root system reaching the sides of the container to maintain a firm root ball, but shall not have excessive root growth outside the container.

PRODUCT DATA SHEET 3 - Bulbs: Provide top size bulbs as indicated on plan in accordance with most current version of ANSI A60 specification.

PRODUCT DATA SHEET 4 - Field grown trees and shrubs shall be grown in soils of the Piedmont region, or west of that region in the above approved states and zones.

- F. All plant materials shall be labeled by grower to identify genus, species, and cultivar, if applicable, in accordance with Section 1.04 "Quality Assurance," above.
- G. Bare root plant materials: Bare root plants will be dug with adequate fibrous roots. Do not root prune. Roots shall be protected during handling and planting to guard against drying out and damage.
- H. Plant Materials for ecologically sensitive areas: Plant materials identified on planting plan as being located within an Arlington County Natural Resource Conservation Area (NCRA) shall be native species of local provenance.
 - a. Plant stock shall originate from a location within 150 miles of Arlington County.

2.02 OTHER MATERIALS

- A. Refer to Section 329200 "Seeding and Sodding" for specifications for seeding, specialty seeding, sodding, and soil stabilization/erosion control fabric.
- B. Refer to Section 329100 "Planting Preparation" for specifications for soils, mulch, soil amendments and other items related to planting preparation.

PART 4 - EXECUTION**3.01 EXTERIOR PLANTING**

- A. Contractor shall install plant materials in accordance with the current Arlington County Standard Planting Details as published on the Arlington County website and as specified below.
- B. Refer to Section 329100 "Planting Preparation" for specifications on soil amendments.
 - a. Remove existing sod, turf, weeds or other plant material.
 - b. Rototill subgrade of planting beds to a minimum depth of 8 inches with the addition of 3 inches' organic material. Edge and rake the entire planting bed.
 - c. Remove stones, clods, debris, sticks, roots and other foreign or extraneous matter larger than 1/2 inch in any dimension. Contractor shall legally dispose of them off Arlington County property.
 - d. Thoroughly blend planting soil mix off-site before spreading or spread topsoil, apply soil amendments and fertilizer on surface, and thoroughly blend planting soil mix.
 - e. Spread planting soil mix to a depth of 8 inches but not less than required to meet finish grades after natural settlement. Do not spread if planting soil or subgrade is frozen, muddy, or excessively wet.
 - f. Finish Grading: Grade planting beds to a smooth, uniform surface plane with loose, uniformly fine texture. Roll and rake, remove ridges, and fill depressions to meet finish grades.

- g. Planting operations shall be performed during periods within the planting season when weather and soil conditions are suitable and in accordance with accepted local practice. Plants shall not be installed in top soil that is in muddy or frozen condition. **Lawns, trees and shrubs shall be installed between 03/15 and 06/15 or between 09/15 and 12/01.** If a project completion is outside of this planting period, contact the Arlington County Urban Forester to obtain a deferral or approval for planting out of season.
 - h.
- C. Plant Layout
 - a. The Contractor shall layout and space plants according to the project landscape plan.
 - b. When the layout is complete, the Contractor shall notify the Project Officer for approval with confirmation by the Landscape Architect prior to installation of the plants.
- D. Landscape Plantings (Trees, Shrubs, Ground Covers and Perennials)
 - a. Contractor shall install plantings in accordance with Arlington County DPR standard details available online at: <http://parks.arlingtonva.us/design-standards/>. Refer to plans for appropriate planting details.
 - b. Handling: Prepare pit and/or planting bed per standards. Place plant in pit by carrying by the root ball (not by branches or trunk) and plant per the DPR Standards. Make sure the plant remains plumb during the backfilling procedure.
- E. Tree and Shrub Pruning: **Contractor shall conform to the most current version of ANSI A-300 Tree Pruning Standards. Do not cut tree leaders; remove only injured or dead branches from trees and shrubs, or those that pose a hazard to pedestrians.** Make all cuts back to a lateral branch or bud. Cuts should be perpendicular above branch collar. Final pruning shall be done after the tree is in place. Do not prune into old wood on evergreens.
- F. Plant Protection: Contractor shall protect exterior plants from damage due to landscape operations, operations by other contractors and trades, and others. Maintain protection during installation and maintenance periods. Treat, repair, or replace damaged exterior planting. Injured roots shall be pruned to clean ends before planting with clean, sharp tools per most current ANSI 300 specifications.
 - a. Protect shrubs, groundcovers and perennials from hot sun and wind; remove protection if plants show evidence of recovery from transplanting shock.

- G. Contractor shall remove all tags, labels, strings and wire from the plants, unless otherwise directed.
- H. Contractor shall remove surplus soil and waste material, including excess subsoil, unsuitable soil, trash, and debris, and legally dispose of them off of Arlington County property.
- I. Refer to Section 1.06 'Water Requirements.'

3.02 STAKING & GUYING TREES

- A. Contractor shall stake and guy trees only if required by Urban Forester.
- B. If staking and guying is required, the Contractor shall provide and install stakes and guying in accordance with DPR standard staking details for deciduous and evergreen trees.

PART 4 – MEASUREMENT AND PAYMENT

- 4.01** The measurement of PLANT to be paid for under this item shall be the number of EACH type of furnished and installed plant in accordance with the approved plans and specifications.
- 4.02** The unit price for each PLANT shall include the cost of all labor, materials, and other expenses necessary to complete the work, including but not limited to required watering's (at time of planting and second watering for each plant 48 hours after installation), and maintenance and watering necessary to keep plants healthy until final acceptance as described herein, in accordance with the approved plans and specifications.
- 4.03** When explicitly specified in plans, the measurement of STAKING AND GUYING to be paid for under this item shall be the number of EACH to furnished and installed at individual trees in accordance with the approved plans and specifications.
- 4.04** The unit price for STAKING AND GUYING shall include the cost of all labor, materials, and other expenses necessary to complete the work in accordance with the approved plans and specifications.

FOLLOWING THIS PAGE IS THE AGREEMENT THAT WILL BE ENTERED INTO BETWEEN THE COUNTY AND THE CONTRACTOR. THE AGREEMENT IS PART OF THIS SOLICITATION. THIS AGREEMENT IS SUBJECT TO REVIEW BY THE COUNTY ATTORNEY PRIOR TO BEING SUBMITTED FOR CONTRACTOR'S SIGNATURE.

IV. AGREEMENT AND CONTRACT TERMS AND CONDITIONS

**ARLINGTON COUNTY, VIRGINIA
OFFICE OF THE PURCHASING AGENT
SUITE 500, 2100 CLARENDON BOULEVARD
ARLINGTON, VA 22201**

AGREEMENT NO. 19-279-ITB

THIS AGREEMENT is made, on the date of execution by the County, between Contractor's name, Contractor's address ("Contractor") a name of state type of entity authorized to do business in the Commonwealth of Virginia, and the County Board of Arlington County, Virginia. The County and the Contractor, for the consideration hereinafter specified, agree as follows:

1. CONTRACT DOCUMENTS

The Contract Documents consist of:

- Agreement No. 19-279-ITB, and all modifications properly incorporated into the Agreement
- Attachment A – Price Schedule
- Attachment B – Master Transportation Plan
- Attachment C – Lane Closures in Nova District
- Attachment D – State and Federal Roads in Arlington County, Virginia
- Attachment E – Arlington County, Virginia Materials Testing Specification Reference Guide (8-18-18)
- Attachment F – N-12 HP Storm Trench Installation Detail
- Attachment G – Biodegradable tree shelter
- Attachment H – Polypropylene tree shelter
- Attachment I – Live Stakes
- Attachment J – Sample plans
- Attachment K – Revised Arlington County Standard Detail M-6.0
- Attachment L – Successful Bidder Submission Documents

Where the terms and provisions of this Agreement vary from the terms and provisions of the other Contract Documents, the order of precedence of the Contract Documents shall be as follows:

Attachments A, B, C, D, E, F, G, H, I, J and K are considered complementary documents, what is in one shall be considered as in all; where the terms of these Contract Documents vary the most stringent shall apply.

The Contract Documents set forth the entire agreement between the County and the Contractor. The County and the Contractor agree that no representative or agent of either party has made any representation or promise with respect to the parties' agreement that is not contained in the Contract Documents. The Contract Documents may be referred to below as the "Contract" or the "Agreement".

2. PROJECT OFFICER

The performance of the Contractor is subject to the review and approval of the County Project Officer who will be appointed by the Director of the Arlington County department or agency requesting the Work under the Contract.

The County has authorized the consultant identified below to act as the County representative for specific purposes to perform specified duties and responsibilities, and to have the rights and authorities as assigned in connection with completion of the Work in accordance with the Contract Documents until such time as the County may notify the Contractor otherwise:

The County will notify the Contractor after contract award of the specific roles and responsibilities of the Consultant(s).

3. SCOPE OF WORK

The Contractor will furnish all labor, materials, and equipment for the construction of Wet Utilities (Storm/Sanitary/Water mains) and associated outfall and stream channel improvements (the "Project") and all other Work shown, described, and required by the Contract Documents (hereinafter "the Work").

The Work shall be performed according to the standards established by the Contract Documents read together as a single specification. It shall be the Contractor's responsibility, at solely the Contractor's cost, to provide sufficient services to fulfill the purposes of the Work. Nothing in the Contract Documents shall be construed to limit the Contractor's responsibility to manage the details and execution of its Work.

4. CONTRACT TERM

The term of this Agreement will commence on the date of execution by the County, and shall be completed no later than 24 consecutive calendar months from the day of the execution of the contract by the County ("Initial Contract Term"), subject to any written modifications as provided for in the Contract Documents. Upon completion of the Initial term, County and Contractor may agree, through bilateral execution of a Contract Amendment, continued operations of the Contractor for not more than three (3) additional twelve (12) month periods.

5. TIME FOR COMPLETION

The County will assign Work, under this contract through the issuance of Task Orders. Prior to each Task Order being issued, there will be discussions by the County with the Contractor of the Scope of Work, timeframe mutually agreed upon for the Final Completion date for each issued Task Order.

The Project Officer will issue the Notice to Proceed that will include the mutually agreed upon Task Order Final Completion date. The Work will not reach Final Completion status until it meets the requirements set forth in the General Conditions. Final Completion will be determined by the inspection and acceptance of the Work by the Project Officer.

6. CONTRACT AMOUNT

The County will pay the Contractor in accordance with the terms of the Progress Payments and Retainage and Payment Terms sections below and at the prices shown in the Price Schedule (Attachment A) for the Contractor's completion of the Work as required by the Contract Documents provided the Work is performed to the satisfaction of and is accepted by the Project Officer.

The Contractor will complete the Work for the total amount specified in this section ("Contract Amount") unless such amount is modified as provided in this Agreement. The Contract Amount includes all of the Contractor's costs and fees (profit) and is inclusive of all anticipated or known site conditions, anticipated or known materials, labor, and equipment costs, or any other costs which should reasonably have been expected by the Contract Documents.

7. PROGRESS PAYMENTS AND RETAINAGE

The County will make monthly progress payments to the Contractor upon written application by the Contractor, on the basis of a written estimate of the Work performed during the preceding calendar month as approved by the Project Officer.

Five Percent (5%) of each progress payment will be retained by the County until Final Completion and acceptance of all Work covered by the Agreement.

All material and Work covered by partial payments will become the property solely of the County at the time the partial payment is made. The Contractor will have the sole responsibility, care and custody for all materials and Work upon which payments have been made until Substantial Completion.

When calculating payment for materials on-site, the County shall not pay for materials which are not scheduled for incorporation into the Work within Sixty (60) days from the date of application for payment.

8. PAYMENT TERMS

The Contractor must submit invoices to the County's Project Officer, who will either approve the invoice or require corrections. The County will pay the Contractor within Thirty (30) days after approval of an invoice for completed Work which is reasonable and allocable to the Contract.

The number of the County Purchase Order pursuant to Work has been performed must appear on all invoices. Unless otherwise specified herein, payment shall not be made prior to delivery and acceptance of the entire Work by the County.

9. PAYMENT OF SUB-CONTRACTORS

The Contractor is obligated to take one of the two following actions within seven days after receipt of payment by the County for Work performed by any subcontractor under this Contract:

- a. Pay the sub-contractor for the proportionate share of the total payment received from the County attributable to the Work performed by the subcontractor under this Contract; or
- b. Notify the County and the sub-contractor, in writing, of the Contractor's intention to withhold all or a part of the subcontractor's payment with the reason for nonpayment.

The Contractor is obligated to pay interest to the subcontractor on all amounts owed by the Contractor to the subcontractor that remain unpaid after seven days following receipt by the Contractor of payment from the County for Work performed by the subcontractor under this Contract, except for amounts withheld as allowed in subsection b., above. Unless otherwise provided under the terms of this Contract, interest will accrue at the rate of 1% per month.

The Contractor must include in each of its subcontracts, if any are permitted, a provision requiring each subcontractor to include or otherwise be subject to the same payment and interest requirements with respect to each lower-tier subcontractor.

The Contractor's obligation to pay an interest charge to a subcontractor pursuant to this section may not be construed to be an obligation of the County. A Contract modification may not be made for the purpose of providing reimbursement for such interest charge. A cost reimbursement claim may not include any amount for reimbursement for such interest charge.

10. RELEASE AND REQUEST FOR FINAL PAYMENT

In order to receive final payment upon Final Completion of the Project and before Final Acceptance, the Contractor must submit to the Project Officer a signed original notarized copy of the Arlington County Release and Request for Final Payment form per the General Conditions.

11. LIQUIDATED DAMAGES

Time is of the essence under this Contract. The Work must be completed within the Time for Completion. The County and the Contractor agree that damages for failure to complete the Work within the Time for Completion are not susceptible to exact determination but that \$1,428.00 per calendar day is in proportion to the actual loss that the County would suffer from such delay.

Therefore, the Contractor will pay the County as liquidated damages \$1,428.00 per day for each and every calendar day beyond the Time for Completion that the County determines the Contractor has not reached Final Completion.

The County will be entitled to deduct liquidated damages against any sums owed by the County to the Contractor under this Contract. The Contractor hereby waives any defense as to the validity of any liquidated damages on grounds that such liquidated damages are void as penalties or are not reasonably related to actual damages.

12. PERFORMANCE OF WORK BY THE CONTRACTOR

The Contractor shall perform on site, and with its own organization, at least Fifty Percent (50%) of the total direct labor and at least Fifty Percent (50%) of the total Work in place to be performed under the Contract. Prior to award, the Contractor must demonstrate to the Project Officer's satisfaction that both of these standards will be met during contract performance.

Labor and Work to be counted when determining whether the Contractor has met the self-performance requirement shall not include any Work that the Contractor performs under the supervision of a sub-contractor.

The self-performance percentage may be reduced by an Amendment to the Contract, if during performance of the Work, the Contractor requests a reduction and the Project Officer determines that the reduction would be to the advantage of the County.

13. NON-APPROPRIATION

All payments by the County to the Contractor pursuant to this Contract are subject to the availability of an annual appropriation for this purpose by the County Board of Arlington County, Virginia ("Board"). In the event that the Board does not appropriate funds for the goods or services provided under this Contract, the County will terminate the Contract, without termination charge or other liability to the County, on the last day of the fiscal year or when the previous appropriation has been spent, whichever occurs first.

14. ESTIMATED QUANTITIES/NON-EXCLUSIVITY OF CONTRACTOR

This Contract does not obligate the County to purchase a specific quantity of items or services during Contract Term. Any quantities that are included in the Contract Documents are the present expectations of the County for the period of the Contract; and the County is under no obligation to buy that or any amount as a result of having provided this estimate or of having had any normal or otherwise measurable

requirement in the past. The County may require more goods and/or services than the estimated annual quantities, and any such additional quantities will not give rise to any claim for compensation other than at the unit prices and/or rates in the Contract.

The County does not guarantee that the Contractor will be the exclusive provider of the goods or services covered by this Contract. The items or services covered by this Contract may be or become available under other County contract(s), and the County may determine that it is in its best interest to procure the items or services through those contract(s).

15. COUNTY PURCHASE ORDER REQUIREMENT

County purchases are authorized only if the County issues a Purchase Order in advance of the transaction, indicating that the ordering County agency has sufficient funds available to pay for the purchase. If the Contractor provides goods or services without a signed County Purchase Order, it does so at its own risk and expense. The County will not be liable for payment for any purchases made by its employees that are not authorized by the County Purchasing Agent.

16. LIEN

It is expressly agreed that after any payment has been made by the County either to the Contractor for Work done, or labor or material supplied under the Contract, the County will have a lien upon all material delivered to the site either by the Contractor, or for the Contractor, which is to be used in the performance of the Contract.

17. EMPLOYMENT DISCRIMINATION BY CONTRACTOR PROHIBITED

During the performance of its Work pursuant to this Contract:

- A. The Contractor will not discriminate against any employee or applicant for employment because of race, religion, color, sex, national origin, age or disability or on any other basis prohibited by state law. The Contractor agrees to post in conspicuous places, available to employees and applicants for employment, notices setting forth the provisions of this nondiscrimination clause.
- B. Notices, advertisements and solicitations placed in accordance with federal law, rule or regulation will be deemed sufficient for meeting the requirements of this section.
- C. The Contractor will state in all solicitations or advertisements for employees that it places or causes to be placed that such Contractor is an Equal Opportunity Employer.
- D. The Contractor will comply with the provisions of the Americans with Disabilities Act of 1990 ("ADA"), which prohibits discrimination against individuals with disabilities in employment and mandates that disabled individuals be provided access to publicly and privately provided services and activities.
- E. The Contractor must include the provisions of the foregoing paragraphs in every subcontract or purchase order of more than \$10,000.00 relating to this Contract so that the provisions will be binding upon each subcontractor or vendor.

18. EMPLOYMENT OF UNAUTHORIZED ALIENS PROHIBITED

In accordance with §2.2-4311.1 of the Code of Virginia, as amended, the Contractor must not during the performance of this Contract knowingly employ an unauthorized alien, as that term is defined in the federal Immigration Reform and Control Act of 1986.

19. DRUG-FREE WORKPLACE TO BE MAINTAINED BY CONTRACTOR

During the performance of this Contract, the Contractor must:

- (i) Provide a drug-free workplace for its employees;
- (ii) Post in conspicuous places, available to employees and applicants for employment, a statement notifying employees that the unlawful manufacture, sale, distribution, dispensation, possession, or use of a controlled substance or marijuana is prohibited in the Contractor's workplace and specifying the actions that will be taken against employees for violating such prohibition;
- (iii) State in all solicitations or advertisements for employees placed by or on behalf of the Contractor that the Contractor maintains a drug-free workplace; and
- (iv) Include the provisions of the foregoing clauses in every sub-contract or purchase order of more than \$10,000.00 relating to this Contract so that the provisions will be binding upon each sub-contractor or vendor.

For the purposes of this section, "workplace" means the site(s) for the performance of the Work required by this Contract.

20. PROJECT STAFF

The County has the right to reasonably reject staff or subcontractors whom the Contractor assigns to the Project. The Contractor must then provide replacement staff or subcontractors satisfactory to the County in a timely manner and at no additional cost to the County. The day-to-day supervision and control of the Contractor's employees and its subcontractors is the sole responsibility of the Contractor.

21. FAILURE TO DELIVER

If the Contractor fails to deliver goods or services in accordance with the Contract terms and conditions, the County, after notice to the Contractor, may procure the goods or services from other sources and hold the Contractor responsible for any resulting additional purchase and administrative costs. The County shall be entitled to offset such costs against any sums owed by the County to the Contractor. However, if public necessity requires the use of nonconforming materials or supplies, they may be accepted at a reduction in price to be determined solely by the County.

22. UNSATISFACTORY WORK

If any of the Work done, or material, goods, or equipment provided by the Contractor, is unsatisfactory to the County the Contractor must, upon notice from the County, immediately remove at the Contractor's expense such unsatisfactory work, material, goods, or equipment and replace the same with work, material, goods, or equipment satisfactory to the County. If the Contractor fails to do so after fifteen (15) days the County shall have the right to remove or replace the rejected work, material, goods, or equipment at the expense of the Contractor and offset the expense and administrative costs against any sums owed to the Contractor. This provision applies during the Contract Term and during any warranty or guarantee period. At the Project Officer's discretion, rather than correction or replacement of the work, an appropriate adjustment to the Contract Amount may be made.

23. TERMINATION

The County may terminate this Contract at any time as follows: (1) for cause, if, as determined by the County, the Contractor is in breach or default or has failed to perform the Work satisfactorily; or (2) for the convenience of the County.

Upon receipt of a notice of termination, the Contractor must not place any further orders or subcontracts for materials, services or facilities; must terminate all vendors and subcontracts, except as are necessary for the completion of any portion of the Work that the County did not terminate; and must immediately deliver all documents related to the terminated Work to the County.

Any purchases that the Contractor makes after the notice of termination will be the sole responsibility of the Contractor, unless the County has approved the purchases in writing as necessary for completion of any portion of the Work that the County did not terminate.

If any court of competent jurisdiction finds a termination for cause by the County to be improper, then the termination will be deemed a termination for convenience.

A. TERMINATION FOR CAUSE, INCLUDING BREACH AND DEFAULT; CURE

1. Termination for Unsatisfactory Performance. If the County determines that the Contractor has failed to perform satisfactorily, then the County will give the Contractor written notice of such failure(s) and the opportunity to cure them within 15 days or any other period specified by the County ("Cure Period"). If the Contractor fails to cure within the Cure Period, the County may terminate the Contract for failure to provide satisfactory performance by providing written notice with a termination date. Upon such termination, the Contractor may apply for compensation for Contract services that the County previously accepted ("Termination Costs"), unless payment is otherwise barred by the Contract. The Contractor must submit any request for Termination Costs, with all supporting documentation, to the County Project Officer within 30 days after the expiration of the Cure Period. The County may accept or reject the request for Termination Costs, in whole or in part, and may notify the Contractor of its decision within a reasonable time.

In the event of termination by the County for failure to perform satisfactorily, the Contractor must continue to provide its services as previously scheduled through the termination date, and the County must continue to pay all fees and charges incurred through the termination date.

2. Termination for Breach or Default. If the County terminates the Contract for default or breach of any Contract provision or condition, then the termination will be immediate after notice of termination to the Contractor (unless the County provides for an opportunity to cure), and the Contractor will not be permitted to seek Termination Costs.

Upon any termination pursuant to this section, the Contractor will be liable to the County for costs that the County must expend to complete the Work, including costs resulting from any related delays and from unsatisfactory or non-compliant Work performed by the Contractor or its subcontractors. The County will deduct such costs from any amount due to the Contractor; or if the County does not owe the Contractor, the Contractor must promptly pay

the costs within 15 days of a demand by the County. This section does not limit the County's recovery of any other damages to which it is entitled by law.

Except as otherwise directed by the County, the Contractor must stop Work on the date of receipt the notice of the termination.

B. TERMINATION FOR THE CONVENIENCE OF THE COUNTY

The County may terminate this Contract in whole or in part whenever the Purchasing Agent determines that termination is in the County's best interest. The County will give the Contractor at least 15 days' notice in writing. The notice must specify the extent to which the Contract is terminated and the effective termination date. The Contractor will be entitled to Termination Costs, as defined above, plus any other reasonable amounts that the parties might negotiate; but no amount will be allowed for anticipatory profits.

Except as otherwise directed by the County, the Contractor must stop Work on the date of receipt of the notice of the termination.

24. INDEMNIFICATION

The Contractor covenants for itself, its employees and its subcontractors to save, defend, hold harmless and indemnify the County and all of its elected and appointed officials, officers, current and former employees, agents, departments, agencies, boards and commissions (collectively the "County Indemnitees") from and against any and all claims made by third parties for any and all losses, damages, injuries, fines, penalties, costs (including court costs and attorneys' fees), charges, liability, demands or exposure resulting from, arising out of or in any way connected with the Contractor's acts or omissions, including the acts or omissions of its employees, vendors, delivery drivers and/or subcontractors, in performance or nonperformance of the Contract. This duty to save, defend, hold harmless and indemnify will survive the termination of this Contract. If the Contractor fails or refuses to fulfill its obligations contained in this section, the Contractor must reimburse the County for any and all resulting payments and expenses, including reasonable attorneys' fees. The Contractor must pay such expenses upon demand by the County, and failure to do so may result in the County withholding such amounts from any payments to the Contractor under this Contract.

25. INTELLECTUAL PROPERTY INDEMNIFICATION

The Contractor warrants and guarantees that in providing services under this Contract neither the Contractor nor any subcontractor is infringing on the intellectual property rights (including, but not limited to, copyright, patent, mask and trademark) of third parties.

If the Contractor or any of its employees or subcontractors uses any design, device, Work or material that is covered by patent or copyright, it is understood that the Contract Amount includes all royalties, licensing fees, and any other costs arising from such use in connection with the Work under this Contract.

The Contractor covenants for itself, its employees and its subcontractors to save, defend, hold harmless, and indemnify the County Indemnitees, as defined above, from and against any and all claims, losses, damages, injuries, fines, penalties, costs (including court costs and attorneys' fees), charges, liability or exposure for infringement of or on account of any trademark, copyright, patented or unpatented invention, process or article manufactured or used in the performance of this Contract. This duty to save, defend, hold harmless and indemnify will survive the termination of this Contract. If the Contractor fails or refuses to fulfill its obligations contained in this section, the Contractor must reimburse the County for

any and all resulting payments and expenses, including reasonable attorneys' fees. The Contractor must pay such expenses upon demand by the County, and failure to do so may result in the County withholding such amounts from any payments to the Contractor under this Contract.

26. COPYRIGHT

By this Contract, the Contractor irrevocably transfers, assigns, sets over and conveys to the County all rights, title and interest, including the sole exclusive and complete copyright interest, in any and all copyrightable works created pursuant to this Contract. The Contractor will execute any documents that the County requests to formalize such transfer or assignment.

The rights granted to the County by this section are irrevocable and may not be rescinded or modified, including in connection with or as a result of the termination of or a dispute concerning this Contract.

The Contractor may not use subcontractors or third parties to develop or provide input into any copyrightable materials produced pursuant to this Contract without the County's advance written approval and unless the Contractor includes this Copyright provision in any contract or agreement with such subcontractors or third parties related to this Contract.

27. OWNERSHIP AND RETURN OF RECORDS

This Contract does not confer on the Contractor any ownership rights or rights to use or disclose the County's data or inputs.

All drawings, specifications, blueprints, data, information, findings, memoranda, correspondence, documents or records of any type, whether written, oral or electronic, and all documents generated by the Contractor or its subcontractors as a result of this Contract (collectively "Records") are the exclusive property of the County and must be provided or returned to the County upon completion, termination, or cancellation of this Contract. The Contractor will not use or willingly cause or allow such materials to be used for any purpose other than performance of this Contract without the written consent of the County.

The Records are confidential, and the Contractor will neither release the Records nor share their contents. The Contractor will refer all inquiries regarding the status of any Record to the Project Officer or to his or her designee. At the County's request, the Contractor will deliver all Records, including hard copies of electronic records, to the Project Officer and will destroy all electronic Records.

The Contractor agrees to include the provisions of this section as part of any contract or agreement related to this Contract into which it enters with subcontractors or other third parties.

The provisions of this section will survive any termination or cancellation of this Contract.

28. CONFIDENTIAL INFORMATION

The Contractor and its employees, agents and subcontractors will hold as confidential all County information obtained under this Contract. Confidential information includes, but is not limited to, nonpublic personal information; personal health information (PHI); social security numbers; addresses; dates of birth; other contact information or medical information about a person; and information pertaining to products, operations, systems, customers, prospective customers, techniques, intentions, processes, plans and expertise. The Contractor must take reasonable measures to ensure that all of its employees, agents and subcontractors are informed of and abide by this requirement.

29. ETHICS IN PUBLIC CONTRACTING

This Contract incorporates by reference Article 9 of the Arlington County Purchasing Resolution, as well as all state and federal laws related to ethics, conflicts of interest or bribery, including the State and Local Government Conflict of Interests Act (Code of Virginia § 2.2-3100 et seq.), the Virginia Governmental Frauds Act (Code of Virginia § 18.2-498.1 et seq.) and Articles 2 and 3 of Chapter 10 of Title 18.2 of the Code of Virginia, as amended (§ 18.2-438 et seq.). The Contractor certifies that its bid was made without collusion or fraud; that it has not offered or received any kickbacks or inducements from any other offeror, supplier, manufacturer or subcontractor; and that it has not conferred on any public employee having official responsibility for this procurement any payment, loan, subscription, advance, deposit of money, services or anything of more than nominal value, present or promised, unless consideration of substantially equal or greater value was exchanged.

30. COUNTY EMPLOYEES

No Arlington County employee may share in any part of this Contract or receive any benefit from the Contract that is not available to the general public.

31. FORCE MAJEURE

Neither party will be held responsible for failure to perform the duties and responsibilities imposed by this Contract if such failure is due to a fire, riot, rebellion, natural disaster, war, act of terrorism or act of God that is beyond the control of the party and that makes performance impossible or illegal, unless otherwise specified in the Contract.

32. AUTHORITY TO TRANSACT BUSINESS

The Contractor must, pursuant to Code of Virginia § 2.2-4311.2, be and remain authorized to transact business in the Commonwealth of Virginia during the entire term of this Contract. Otherwise, the Contract is voidable at the sole option of and with no expense to the County.

33. RELATION TO THE COUNTY

The Contractor is an independent contractor, and neither the Contractor nor its employees or subcontractors will be considered employees, servants or agents of the County. The County will not be responsible for any negligence or other wrongdoing by the Contractor or its employees, servants or agents. The County will not withhold payments to the Contractor for any federal or state unemployment taxes, federal or state income taxes or Social Security tax or for any other benefits. The County will not provide to the Contractor any insurance coverage or other benefits, including workers' compensation.

34. ANTITRUST

The Contractor conveys, sells, assigns and transfers to the County all rights, title and interest in and to all causes of action under state or federal antitrust laws that the Contractor may have relating to this Contract.

35. REPORT STANDARDS

The Contractor must submit all written reports required by this Contract for advance review in a format approved by the Project Officer. Reports must be accurate and grammatically correct and should not contain spelling errors. The Contractor will bear the cost of correcting grammatical or spelling errors and inaccurate report data and of other revisions that are required to bring the report(s) into compliance with this section.

Whenever possible, proposals must comply with the following guidelines:

- printed double-sided on at least Thirty Percent (30%) re-cycled-content and/or tree-free paper
- recyclable and/or easily removable covers or binders made from recycled materials (proposals with glued bindings that meet all other requirements are acceptable)
- avoid use of plastic covers or dividers
- avoid unnecessary attachments or documents or superfluous use of paper (e.g. separate title sheets or chapter dividers)

36. AUDIT

The Contractor must retain all books, records and other documents related to this Contract for at least five years, or such period of time required by the County's funding partner(s), if any, whichever is greater, after the final payment and must allow the County or its authorized agents to examine the documents during this period and during the Contract Term.

The Contractor must provide any requested documents to the County for examination within Fifteen (15) days of the request, at the Contractor's expense. Should the County's examination reveal any overcharging by the Contractor, the Contractor must, within Thirty (30) days of County's request, reimburse the County for the overcharges and for the reasonable costs of the County's examination, including, but not limited to, the services of external audit firm and attorney's fees; or the County may deduct the overcharges and examination costs from any amount that the County owes to the Contractor.

If the Contractor wishes to destroy or dispose of any records related to this Contract (including confidential records to which the County does not have ready access) within Five(5) years after the final payment, or such period of time required by the County's funding partner(s), if any, whichever is greater, the Contractor must give the County at least Thirty (30) days' notice and must not dispose of the documents if the County objects.

37. ASSIGNMENT

The Contractor may not assign, transfer, convey or otherwise dispose of any award or any of its rights, obligations or interests under this Contract without the prior written consent of the County.

38. AMENDMENTS

This Contract may not be modified except by written amendment executed by persons duly authorized to bind the Contractor and the County.

39. ARLINGTON COUNTY PURCHASING RESOLUTION AND COUNTY POLICIES

Nothing in this Contract waives any provision of the Arlington County Purchasing Resolution, which is incorporated herein by reference, or any applicable County policy.

40. DISPUTE RESOLUTION

All disputes arising under this Agreement or concerning its interpretation, whether involving law or fact and including but not limited to claims for additional work, compensation or time, and all claims for alleged breach of contract must be submitted in writing to the Project Officer as soon as the basis for the claim arises. In accordance with the Arlington County Purchasing Resolution, claims denied by the Project Officer may be submitted to the County Manager in writing no later than 60 days after the final payment. The time limit for a final written decision by the County Manager is 30 days. Procedures concerning

contractual claims, disputes, administrative appeals and protests are contained in the Arlington County Purchasing Resolution. The Contractor must continue to Work as scheduled pending a decision of the Project Officer, County Manager, County Board or a court of law.

41. APPLICABLE LAW, FORUM, VENUE, AND JURISDICTION

This Contract is governed in all respects by the laws of the Commonwealth of Virginia; and the jurisdiction, forum and venue for any litigation concerning the Contract or the Work is in the Circuit Court for Arlington County, Virginia, and in no other court.

42. ARBITRATION

No claim arising under or related to this Contract may be subject to arbitration.

43. NONEXCLUSIVITY OF REMEDIES

All remedies available to the County under this Contract are cumulative, and no remedy will be exclusive of any other at law or in equity.

44. NO WAIVER

The failure to exercise a right provided for in this Contract will not be a subsequent waiver of the same right or of any other right.

45. SEVERABILITY

The sections, paragraphs, clauses, sentences, and phrases of this Contract are severable; and if any section, paragraph, clause, sentence or phrase of this Contract is declared invalid by a court of competent jurisdiction, the rest of the Contract will remain in effect.

46. ATTORNEY'S FEES

In the event the County prevails in any legal action or proceeding brought by the County to enforce any provision of this Contract, the County is entitled to reasonable attorney's fees and costs.

47. SURVIVAL OF TERMS

In addition to any statement that a specific term or paragraph survives the expiration or termination of this Contract, the following sections also survive: **INDEMNIFICATION; INTELLECTUAL PROPERTY INDEMNIFICATION; RELATION TO COUNTY; OWNERSHIP AND RETURN OF RECORDS; AUDIT; COPYRIGHT; DISPUTE RESOLUTION; APPLICABLE LAW AND JURISDICTION; ATTORNEY'S FEES, AND CONFIDENTIAL INFORMATION.**

48. HEADINGS

The section headings in this Contract are inserted only for convenience and do not affect the substance of the Contract or limit the sections' scope.

49. AMBIGUITIES

The parties and their counsel have participated fully in the drafting of this Agreement; and any rule that ambiguities are to be resolved against the drafting party does not apply. The language in this Agreement is to be interpreted as to its plain meaning and not strictly for or against any party.

50. NOTICES

Unless otherwise provided in writing, all legal notices and other communications required by this Contract are deemed to have been given when either (a) delivered in person; (b) delivered by an agent, such as a

delivery service; or (c) deposited in the United States mail, postage prepaid, certified or registered and addressed as follows:

TO THE CONTRACTOR:

TO THE COUNTY:

_____, Project Officer

AND

Sharon Lewis, Purchasing Agent
Arlington County Government
Office of the Purchasing Agent
2100 Clarendon Boulevard
Suite 500
Arlington, Virginia 22201

51. NON-DISCRIMINATION NOTICE

Arlington County does not discriminate against faith-based organizations.

52. INSURANCE, PAYMENT AND PERFORMANCE BONDS

The Contractor shall maintain the required insurance coverage and payment and performance bonds through completion of the Contract, including all warranty and guarantee periods.

WITNESS these signatures:

**THE COUNTY BOARD OF ARLINGTON COUNTY,
VIRGINIA**

CONTRACTOR

**AUTHORIZED
SIGNATURE: _____**

**AUTHORIZED
SIGNATURE: _____**

**NAME SHARON LEWIS
TITLE: PURCHASING AGENT**

**NAME
TITLE: _____**

DATE: _____

DATE: _____

V. ARLINGTON COUNTY DES ENGINEERING PROJECT
GENERAL CONDITIONS

TABLE OF CONTENTS

- A) INTRODUCTION TO TERMS

- B) DRAWINGS, SPECIFICATIONS AND RELATED DATA
 - 1) INTENT OF THE DRAWINGS AND SPECIFICATIONS
 - 2) DISCREPANCIES AND ERRORS
 - 3) DIFFERING SITE CONDITIONS
 - 4) COPIES FURNISHED
 - 5) USE OF CADD FILES
 - 6) DOCUMENTS ON THE JOBSITE
 - 7) OWNERSHIP OF DRAWINGS AND SPECIFICATIONS
 - 8) SUBMITTALS
 - 9) SAMPLES
 - 10) TESTS
 - 11) MATERIALS AND EQUIPMENT LIST
 - 12) STANDARDS, SUBSTITUTIONS
 - 13) SURVEYS AND CONTROLS
 - 14) RECORD DRAWINGS

- C) COUNTY, COUNTY PROJECT OFFICER, AND CONTRACTOR RELATIONS
 - 1) STATUS OF COUNTY PROJECT OFFICER OR DESIGNEE
 - 2) LIMITATION ON COUNTY'S RESPONSIBILITIES
 - 3) DISPUTES
 - 4) INSPECTION OF THE WORK
 - 5) INSPECTION OF MATERIALS
 - 6) EXAMINATION OF COMPLETED WORK
 - 7) RIGHT TO SUSPEND WORK
 - 8) RIGHT TO CARRY OUT THE WORK
 - 9) SUPERINTENDENCE BY CONTRACTOR
 - 10) DRUG-FREE POLICY
 - 11) LANDS BY COUNTY
 - 12) LANDS BY CONTRACTOR
 - 13) PROTECTION OF WORKAND PROPERTY
 - 14) SEPARATE CONTRACTS
 - 15) SUBCONTRACTS
 - 16) ELIMINATED ITEMS
 - 17) COUNTY ORDINANCES

- D) MATERIALS AND WORKMANSHIP
 - 1) MATERIALS FURNISHED BY THE CONTRACTOR
 - 2) IBC AND VUSBC REQUIREMENTS
 - 3) ADA COMPLIANCE
 - 4) MANUFACTURER'S DIRECTIONS
 - 5) WARRANTY
 - 6) INSPECTION, ACCEPTANCE AND TITLE TO MATERIALS
 - 7) CONTRACTOR'S TITLE TO MATERIALS
 - 8) TITLE TO MATERIALS AND WORKCOVERED BY PARTIAL PAYMENTS
 - 9) CUTTING, PATCHING AND DIGGING
 - 10) REJECTED WORKAND MATERIALS
 - 11) PROHIBITION AGAINST ASBESTOS CONTAINING MATERIALS

- E) LEGAL RESPONSIBILITY AND PUBLIC SAFETY
 - 1) SITE INVESTIGATION AND CONDITIONS AFFECTING THE WORK
 - 2) PUBLIC CONVENIENCE
 - 3) SAFETY AND ACCIDENT PREVENTION
 - 4) HAZARDOUS MATERIALS
 - 5) HAZARDOUS WASTE
 - 6) ASBESTOS
 - 7) CROSSING UTILITIES
 - 8) OVERHEAD HIGH VOLTAGE LINES SAFETY ACT
 - 9) SANITARY PROVISIONS
 - 10) SITE CLEAN-UP AND WASTE DISPOSAL
 - 11) STORMWATER POLLUTION PREVENTION PLAN (SWPPP)

- F) PROGRESS AND COMPLETION OF THE WORK
 - 1) NOTICE TO PROCEED
 - 2) TIME FOR COMPLETION
 - 3) SCHEDULE OF COMPLETION
 - 4) CONDITIONS FOR COMPLETION
 - 5) USE OF COMPLETED PORTIONS

- G) MEASUREMENT AND PAYMENT
 - 1) PAYMENTS TO CONTRACTOR
 - 2) PAYMENT FOR STORED MATERIALS
 - 3) PAYMENTS WITHHELD
 - 4) COUNTY ORDERED CHANGES IN WORK
 - 5) FORCE ACCOUNT WORK
 - 6) CLAIMS FOR EXTRA COST
 - 7) DAMAGES FOR DELAY; EXTENSIONS OF TIME FOR OTHER THAN WEATHER
 - 8) TIME EXTENSIONS FOR WEATHER
 - 9) RELEASE OF LIENS
 - 10) FINAL PAYMENT

A. INTRODUCTION TO TERMS

- 1) The term "Agreement" means the completed and signed Form of Contract Agreement.
- 2) The term "Award Date" means the date of execution of the Agreement by the Purchasing Agent.
- 3) The term "Business Day" shall refer to any day that the County is open for general business.
- 4) The term "Calendar Day" means any day of twenty-four hours measured from midnight to the next midnight. Included are weekends and holidays. When the term "Day" is used it shall be assumed to refer to a Calendar Day unless otherwise specified.
- 5) The term "Change Order" means a written order to the Contractor, signed by the Project Officer and the Contractor, which authorizes a change in the Work, and/or adjustment to the Contract Amount and/or an adjustment to the Time for Completion. A Change Order once signed by all the parties is incorporated into and becomes part of the Contract.
- 6) The term "Commencement Date" means the date on which the Time for Completion will commence for the Contractor to begin to perform his obligations under the Contract Documents as provided in the Notice to Proceed.
- 7) The term "Construction Change Directive" means a written order issued by the County directing a change in the Work prior to agreement on adjustment, if any, in the Contract Amount or Contract Time, or both.
- 8) The term "Contract Documents" means the Agreement and all the documents and Attachments identified therein which shall include the Drawings and the Specifications, and all modifications including amendments and subsequent Change Orders thereto properly incorporated in the Contract.
- 9) The terms "County" and "Contractor" shall mean the respective parties to the Contract. They shall be treated throughout the Contract Documents as though each were of the singular number and masculine gender. Only one Contractor is recognized as a party to this Contract.
- 10) The term "Critical Path Method or CPM" means a step-by-step project management technique for process planning that defines critical and non-critical tasks with the goal of preventing time-frame problems and process bottlenecks. An activity on the critical path cannot be started until its predecessor activity has been completed. is delayed then the entire project is delayed.

- 11) The term "Delay" means an event or condition that results in a Work activity starting or being completed later than originally planned.
- 12) The term "Drawings" means all drawings pertaining to the Contract, including the Contract Drawings and Construction Notes which show and describe the locations, character, dimensions, and details of the Work to be performed under the contract.
- 13) The term "Final Acceptance" shall mean the date on which the County issues the final payment for the Work.
- 14) The term "Final Completion" shall mean the condition when the County agrees that all the Work has been fully completed in accordance with the Contract Documents and is acceptable. The date of the Final Completion of the Work under the Contract is the date on which Final Completion is accomplished.
- 15) The term "Float" shall represent the amount of time that a task in a project net Work or sequence can be delayed without causing a delay to: subsequent tasks ("free float") or project completion date ("total float"). Float shall belong to the County and shall be used for the successful completion of the Project within the Time for Completion.
- 16) The term "Notice to Proceed" shall mean a written notice issued by the County to the Contractor stating the Commencement Date. The Notice to Proceed will specify the Time for Completion of the Contract.
- 17) The term "Project" means the entire proposed construction to be executed as stipulated in the Contract Documents
- 18) The term "Project Officer" means the County Project Officer assigned by the Director of the County Department responsible for the project, or the Director's designee. When a designee to act on behalf of the Project Officer is used by the County, the name of the designee and the duties and authority of such designee will be identified in the Contract Documents or in a written notice to the Contractor from the Project Officer responsible for the project. The designee may be a professional architect or engineer or other person employed by the County to perform construction services administration, design services, or project oversight.
- 19) The term "Punch List" means unfinished items of the construction of the Project, which unfinished items of construction are minor or insubstantial details of construction, mechanical adjustment or decoration remaining to be performed, the non-completion of which would not materially affect use of the Project, and which are capable of being completed within the time specified for Final Completion after Substantial Completion has been achieved.
- 20) The term "Request for Information" (RFI) means a request originated by the Contractor requesting clarification or additional information from the Project

Officer and/or Architect/Engineer concerning information in the construction documents where the Contractor believes there is insufficient information or a conflict in the documents. RFI's shall be submitted by the Contractor sufficiently in advance of the Work to provide time for assessment and response without delay of the Work. Responses to RFI's shall not be construed as authorization for a Change Order.

- 21) The term "Schedule of Values" means a listing of the Contractor's total contract value by Construction Specifications Institute (CSI) divisions, including Division 1, Contractor's General Conditions.
- 22) The term "Site" refers to that portion of the property on which the Work is to be performed or which has otherwise been set aside for use by the Contractor.
- 23) The terms "Special Conditions" mean the written statements modifying or supplementing the Technical Specifications or General Conditions for requirements or conditions peculiar to the Contract.
- 24) The term "Specifications" means and shall include the Technical Specifications, the Special Conditions and all written agreements and instructions pertaining to the performance of the Work.
- 25) When used, the term "Stipulated Price Item" means and includes an item of Work, unanticipated or of unknown quantity at the time of issuance of the solicitation for a Bid and determined to be executed, based on the actual field conditions during the progress of Work under the Contract. The Unit Price for the "Stipulated Price Item", as identified in the "Stipulated Price Items" section of the Bid Form, is predetermined by the County as the current reasonably workable rate for the Item inclusive of all necessary labor, equipment, materials, overheads (provision and installation), and the contractor's profit.
- 26) The term "Subcontractor", shall include only those having a direct contract with the Contractor, and it shall include those who furnish material worked to a special design according to the plans and specifications for this Work but shall not include those who merely furnish material not so worked.
- 27) The term "Substantial Completion" shall mean the condition when the County agrees that the Work, or a specific portion thereof, is sufficiently complete, in accordance with the Contract Documents, so that it can be utilized by the County for the purposes for which it was intended. The date of Substantial Completion of the Work under the Contract is the milestone date on which Substantial Completion condition is accomplished.

- 28) The term "Technical Specifications" means that part of the Contract Documents that describe the quality of materials, method of installation, standard of workmanship, and the administrative and procedural requirements for the performance of the Work under the contract.
- 29) The term "Time for Completion" shall mean the time period set forth in the Agreement.
- 30) The term "Work" shall mean the services performed under this Contract including, but not limited to, furnishing labor, and furnishing and installing materials and equipment required to complete the Project specified in the Contract Documents.

B. DRAWINGS, SPECIFICATIONS, RELATED DATA AND RECORDS KEEPING

1. INTENT OF THE DRAWINGS AND SPECIFICATIONS

- a. It is understood that, except as otherwise specifically stated in the Contract Documents, the Contractor shall provide and pay for all materials, labor, tools, equipment, water, water haulage, light power, transportation, superintendence, temporary construction of all kinds, and other services and facilities of every nature whatsoever that are necessary to execute and deliver the Work, complete and usable within the scope of the Contract with all parts in working order, and all connections properly made.
- b. The general character and scope of the Work are illustrated by the Drawings and listed in the Specifications. Any additional drawings and or other instructions deemed necessary by the Project Officer or designee will be furnished to the Contractor when required for the Work and shall be incorporated into the Contract Documents.
- c. Where "as shown", "as indicated", "as detailed", or words of similar import are used, it shall be understood that direction, requirements, permission, or review of Project Officer or designee is intended unless stated otherwise. As used herein, "provide" shall be understood to mean "provide complete in place", that is, "furnish and install."
- d. Unless otherwise specifically noted, the word "similar" where it occurs in the Drawings, shall be interpreted in its general sense and not as meaning identical, and all details shall be worked out in relation to their locations and their connection with other parts of the Work.
- e. Materials or Work described in words which, so applied, have a well-known technical, construction industry, or trade meaning, shall be held to refer to the recognized technical or trade meaning.

f. The Contract Documents are complementary, and what is called for by any one document shall be as binding as if called for by all documents. In case of conflicting variance between the Contract Documents, the Order of Precedence stated in the Agreement shall govern. Figured dimensions on the plans shall be used; drawings shall not be scaled.

2. DISCREPANCIES AND ERRORS

If the Contractor discovers any discrepancies between the Drawings and Specifications and the site conditions or any errors or omissions in the Drawings or Specifications, the Contractor shall at once, but in no event later than three calendar days after discovery of the discrepancy or error, report them in writing to the Project Officer or designee. If the Contractor proceeds with any Work that may be affected by such discrepancies, errors, or omissions, after their discovery, but before a clarification is provided, such Work shall be at the Contractor's risk and expense. Issues affecting critical path activities shall be made known to the Project Officer or designee within one business day after discovery.

3. DIFFERING SITE CONDITIONS

The Contractor shall immediately, and before the conditions are further disturbed, give notice to the Project Officer of subsurface or latent physical conditions at the site which differ materially from those indicated in this Contract, or previously unknown physical conditions discovered at the site of an unusual nature and which differ materially from those ordinarily expected to be encountered at the site. Such notice shall be followed by a written notice provided within 48 hours of discovery.

The Project Officer will investigate the site conditions promptly after receiving the notice. If the conditions do materially differ to the extent that an increase or decrease would result in the Contractor's cost of the Work, or the time required for performing any part of the Work under the contract, an equitable adjustment may be made under this clause and the Contract modified in writing accordingly.

No request by the Contractor for an adjustment to the Contract under this clause shall be allowed, unless the Contractor has given the written notice required. If the Contractor proceeds with any Work that may be affected by such differing site conditions before giving notice to the Project Officer as set forth herein, such Work shall be at the Contractor's sole risk and expense.

No request by the Contractor for an adjustment to the contract for differing site conditions shall be allowed if made after Final Payment under the Contract.

4. COPIES FURNISHED

Except as provided for otherwise, copies of the Drawings and Specifications reasonably necessary for the execution of the Work will be furnished to the Contractor. One electronic copy of the Contract Drawings and Specifications will be provided by the Project Officer or designee to the Contractor.

5. USE OF CADD FILES

The Contractor may request Electronic CADD files related to the Work or the Project. The CADD files will be provided by the County only if the Contractor completes the Arlington County Electronic CADD Drawing Release Form, which form is then incorporated by reference into this Contract. Use of CADD files is at the Contractor's own risk and in no way alleviates Contractor's responsibility for the Work to conform to the Plans and Specifications.

6. DOCUMENTS ON THE JOBSITE

The Contractor shall keep on the site of the Project a copy of the Drawings and Specifications updated to include all authorized revisions and RFI responses, and shall at all times give the County and its authorized representatives access thereto. The Contractor shall mark up the Drawings on a daily basis in red. The drawings shall be submitted to the County at Substantial Completion as the Record marked up set.

7. OWNERSHIP OF DRAWINGS AND SPECIFICATIONS

All Drawings and Specifications and copies thereof furnished by the County are the property of the County and shall not be used on other projects. All copies of the Drawings and Specifications except the signed Contract sets shall be returned to the Project Officer or designee at Final Completion.

8. SUBMITTALS

- a. The term "submittals", as used herein, shall include fabrications, erection and setting drawings, manufacturers' standard drawings, schedules, descriptive literature, catalogs, brochures, performance and test data, wiring and control diagrams, and other descriptive data pertaining to the materials and equipment as required to demonstrate compliance with the Contract requirements.
- b. The Contractor shall submit for the review of the Project Officer or designee a listing of all submittals required by the specifications or requested by the Project Officer or designee within fifteen (15) calendar days after receipt of the Notice to Proceed. This listing shall include due dates for each required submittal, coordinated with the project schedule such that adequate time is allotted for review and potential resubmittals, fabrication and delivery without causing delay. The Contractor bears all risk for delay associated with submittals not received in a timely manner.
- c. Submittals shall be submitted in such number of copies as established in the specifications. Each submission shall be accompanied by a letter of transmittal, listing the contents of the submission and identifying each item by reference to specification section or drawing. All submittals shall be clearly labeled with the name of the project and such information as may be necessary to enable their complete review by the

Project Officer or designee. Catalog plates and other similar material that cannot be so labeled conveniently shall be bound in suitable covers bearing the identifying data.

- d. Submittals shall be accompanied by all required certifications and other such supporting material, and shall be submitted in sequence or groups that all related items can be checked together. When submittals cannot be checked because a submission is not complete, or because submittals on related items have not been received by the Project Officer or designee, then such submittals will be returned without action or will be held, not checked, until the missing material is received. Incomplete or defective submittals shall not be considered to have been submitted. Failure to deliver submittals within the specified time will not be grounds for additional time or compensation.
- e. Submittals shall have been reviewed by the Contractor and coordinated with all other related or affected Work before they are submitted for review and acceptance and shall bear the Contractor's certification that the Contractor has checked and approved them as complying with all relevant information in the Contract Documents. Submittals submitted without such certification and coordination will be returned to the Contractor without action and will not be considered as a formal submission.
- f. If shop drawings show variations from the Drawings and Specifications because of standard shop practice or other reasons, the Contractor shall make specific mention of such variation in the Contractor's letter of transmittal in order that, if acceptable, suitable action may be taken for proper adjustment; otherwise the Contractor will not be relieved of the responsibility for executing the Work in accordance with the Drawings and Specifications even though shop drawings have been accepted.
- g. The Project Officer or designee shall review the shop drawings with reasonable promptness. Review and/or acceptance of shop drawings will be general for conformance with the design concept of the Project and compliance with the information given in the Contract Documents, and will not include quantities, detailed dimensions, nor adjustments of dimensions to actual field conditions. Acceptance shall not be construed as permitting any departure from Contract requirements, as authorization of any increase in price nor as relieving the Contractor of the responsibility for any error in details, dimensions or otherwise that may exist. Review is not intended to relieve the contractor of full responsibility for the accuracy and completeness of the plans and calculations, or for the complete compliance with the contract documents. Contractor is solely responsible for the means and methods of the construction, including temporary items proposed for use.

9. SAMPLES

The Contractor shall submit to the Project Officer or designee, all samples required by the specifications or requested by the Project Officer or designee. Samples shall be submitted in single units only, unless the Contractor desires additional units for the Contractor's own use. Each sample shall bear a label indicating what the material represented, the name of the producer and the title of the Project. Acceptance of a sample shall be only for conformance with the design concept of the Project and compliance with the information given in the Contract Documents, and only for the characteristics or use named in such acceptance. Such acceptance shall not be construed to change or modify any Contract requirements or the Contract Price. Materials and equipment incorporated in the Work shall match the accepted samples. The Contractor shall be responsible for researching the availability of the specified product in the dimensions and colors specified at no additional cost to the County. Failure of the contractor to identify specified products that are not commercially produced within the time required for submittal transmittal in order to meet the project schedule shall not be entitled to additional time or compensation.

10. TESTS

Any specified tests of materials and finished articles shall be made by bureaus, laboratories or agencies approved by the Project Officer or designee and the certified reports of such tests shall be submitted to the Project Officer or designee. All tests shall be in compliance with the specifications. All costs in connection with the testing and test failures shall be borne by the Contractor. Failure of any material to pass the specified tests or any test performed by the Project Officer or designee, will be sufficient cause for refusal to consider, under this Contract, any further materials of the same brand or make of that material. Samples of various materials delivered on the site or in place may be taken by the Project Officer or designee for testing. Samples failing to meet the Contract requirements will automatically void previous acceptance of the items tested. The Contractor will not be compensated for additional time and/or cost incurred in finding an acceptable replacement or the removal and replacement of the defective item.

11. MATERIALS AND EQUIPMENT LIST

- a. Within thirty (30) days of the Commencement Date the Contractor shall submit to the Project Officer or designee a complete list of materials and equipment proposed for use in connection with the project. Partial lists submitted from time to time will not be considered unless specifically approved by the Project Officer or designee.
- b. After any material or piece of equipment has been approved through submittal process, no change in brand or make will be permitted unless satisfactory written evidence is presented to prove that the manufacturer cannot make scheduled delivery of the accepted material, or that material delivered has been rejected and the substitution of a suitable material is an urgent necessity, or that other conditions have

become apparent which indicate that acceptance of such other material is in the best interest of the County. The Contractor is solely responsible for the cost and time required to obtain and install a suitable replacement.

12. STANDARDS, SUBSTITUTIONS

- a. Any material specified by reference to the number, symbol or title of a specific standard, such as a Commercial Standard, a Federal Specification, a Trade Association Standard, or other similar standard, shall comply with the requirements in the latest revision of the standards or specification and any amendment or supplement, except as limited to type, class or grade, or as modified in such reference. The standard referred to, except as modified in the Specifications, shall have full force and effect as though printed in the Specifications.
- b. Reference in the Specifications or on the Drawings to any article, device, product, material, fixture, form or type of construction by name, make or catalog number shall be interpreted as establishing a standard of quality and shall not be construed as eliminating from competition other products of equal or better quality by other approved manufacturers. Otherwise, applications for acceptance of substitutions for the specified items will be considered only upon request of the Contractor, not of individuals, trades or suppliers, and only for a specific purpose; no blanket acceptance will be granted. No acceptance of a substitution shall be valid unless it is in written form and signed by the Project Officer or designee.
- c. If any proposed substitution will affect a correlated function, adjacent construction or the Work of other contractors, then the necessary changes and modifications to the affected Work shall be considered as an essential part of the proposed substitution, to be accomplished by the Contractor without additional expense to the County or an extension of the contract time, if and when accepted. Detail drawings and other information necessary to show and explain the proposed modifications shall be submitted with the request for acceptance of the substitution.

13. SURVEYS AND CONTROLS

Unless otherwise specified, the Contractor shall establish all baselines for the location of the principal component parts of the Work, establish a suitable number of benchmarks adjacent to the Work, and develop all detail surveys necessary for construction by a professional land surveyor licensed in the Commonwealth of Virginia. The Contractor shall carefully preserve benchmarks, reference points and stakes, and in the case of destruction thereof by the Contractor or due to the Contractor's negligence or the negligence of any subcontractor or supplier, the Contractor shall be responsible for expense and damage resulting therefrom and shall be responsible for any mistakes that may

be caused by the loss or disturbance of such benchmarks, reference points and stakes. The Contractor shall within 30 days of NTP perform a full site survey to verify all control points shown on the drawings against existing conditions within the site limits. Any discrepancies found during this effort shall be made known immediately to the Project Officer. Failure to perform this survey and provide proof and acceptance of Project datum, control points, and existing benchmarks will not give rise to any extensions to contract time or amount. The cost of all necessary surveying services shall be considered incidental to the Work and, unless otherwise specified, shall be included in the cost of the Work.

14. RECORD DRAWINGS

Record drawings shall be the responsibility of the Contractor. The Contractor shall maintain and mark up one set of prints of the applicable Contract Drawings to portray record construction. The prints shall be neatly and clearly marked in red to show all variations between the Work actually provided and that indicated on the Contract Drawings, and all utilities encountered in the Work. All drafting shall conform to good drafting practice and shall include such supplementary notes, legends and details as may be necessary for legibility and clear portrayal of the record construction. These drawings shall be marked promptly upon any approved change to the Work or discovery of any undocumented utility or obstruction and shall be submitted to the Project Officer or designee in sufficient time to be approved no later than thirty (30) calendar days after the Substantial Completion Date. The final record drawings approved by the Project Officer or designee shall be submitted in paper copy and .pdf format electronic files prior to Final Completion. Unless otherwise required under the Contract Documents, incorporation of red-lined changes into CADD format shall be the responsibility of the Architect and/or Engineer of Record, with the exception being any documents prepared by the Contractor in CADD, the record version of which shall also be provided to the County in CADD format by the Contractor. Final payments will be held until the complete set of red-line drawings are submitted to and approved by the Project Officer.

C. COUNTY, COUNTY PROJECT OFFICER, AND CONTRACTOR RELATIONS

1. STATUS OF COUNTY PROJECT OFFICER OR DESIGNEE

The Project Officer or designee shall be the County's representative during the construction period. All Contractor instructions or requests shall be issued from or submitted through the Project Officer or designee. The Project Officer or designee shall have authority to suspend the Work whenever such suspension may be necessary in the responsible opinion of the Project Officer or designee to ensure the proper execution of the Contract. The Project Officer or designee shall also have authority to reject all Work and materials that do not conform to the Contract and to decide questions that arise in the execution of the Work. The County Project Officer or designee will, within a reasonable time, make decisions on all matters relating to the execution and progress of the Work.

2. LIMITATION ON COUNTY'S RESPONSIBILITIES

The County shall not supervise, direct, or have control or authority over, nor be responsible for: The Contractor's means, methods, techniques, sequences or

procedures of construction; the safety precautions and programs related to safety, or the Contractor's failure to perform or furnish the Work in accordance with the Contract Documents.

3. DISPUTES

- a. All disputes or claims arising under this Contract or its interpretation, whether involving law or fact or both, or extra work, and all claims for alleged breach of Contract shall be submitted in writing to the Project Officer or designee as set forth in these General Conditions. Such claims must set forth in detail the amount of the claim, and shall state the facts surrounding it in sufficient detail to identify it together with its character and scope.
- b. Claims denied by the Project Officer shall be processed in accordance with the procedures outlined in Sections 7-107, Contractual Disputes and 7-108, Legal Actions of the Arlington County Purchasing Resolution and the Dispute Resolution paragraph in the Agreement.
- c. The Contractor shall not cause a delay in the Work pending a decision of the Project Officer or designee, County Manager, County Board, or court, except by prior written approval of the Project Officer or designee.

4. INSPECTION OF WORK

The Project Officer or designee and representatives of any public authority having jurisdiction shall, at all times, have access to the Work while in progress. The Contractor shall provide suitable facilities for such access and for proper observation of the Work and shall conduct all special tests required by the specifications, the Project Officer or designee's instructions, and any laws, ordinances or the regulations of any public authority applicable to the work. Nothing in this section shall abrogate or otherwise limits or relieves the Contractor's independent duty to inspect the Work.

5. INSPECTION OF MATERIALS

All articles, materials, and supplies purchased by the Contractor for the Work are subject to inspection upon delivery to the site and during manufacturing or fabrication. The County reserves the right to return for full credit, at the risk and expense of the Contractor, all or part of the articles, materials, or supplies furnished contrary to specifications and instructions. Nothing in this section shall abrogate or otherwise limit or relieve the Contractor's independent duty to inspect materials.

6. EXAMINATION OF COMPLETED WORK

If the Project Officer or designee requests it, the Contractor, at any time before acceptance of the Work, shall remove or uncover such portions of the finished Work as may be directed. After examination, the Contractor shall restore said portions of the Work to the standard required by the Specifications. Should the Work thus exposed or examined prove acceptable, then the uncovering or removing, and the replacing of the covering or making good of the parts removed shall be paid for as extra work, but should the Work so exposed or examined prove unacceptable, then the uncovering, removing and replacing shall be at the Contractor's expense.

7. RIGHT TO SUSPEND WORK

The County shall have the authority to suspend the Work, in whole or in part, for such periods and such reasons as the County may deem necessary or desirable. Any such suspension shall be in writing to the Contractor and the Contractor shall obey such order immediately and not resume the Work until so ordered in writing by the County. No such suspension of the Work shall be the basis for a claim by the Contractor for any increase in the Contract Amount provided that the suspension is for a reasonable time under the circumstances then existing. If the suspension of Work is caused by the County's belief that non-conforming Work is being installed, and subsequent investigation proves that the Work was non-conforming, the Contractor shall not be awarded additional time or costs.

8. RIGHT TO CARRY OUT THE WORK

If the Contractor defaults or neglects to carry out the Work in accordance with the Contract Documents and fails within a 10-day period after receipt of written notice from the County or such shorter time as may be reasonable under the circumstances, to commence and continue correction of such default or neglect with diligence and promptness, the County may, without prejudice to other remedies the County may have, correct such deficiencies. In such case an appropriate Change Order shall be issued deducting from payments then or thereafter due the Contractor the reasonable cost of correcting such deficiencies, including the County's expenses, and any additional architect or engineering costs necessary by Contractor's default, neglect or failure. If payments then or thereafter due the Contractor are not sufficient to cover such amounts, the Contractor shall pay the difference to the County upon demand.

9. SUPERINTENDENCE BY CONTRACTOR

The Contractor shall keep a competent superintendent and any necessary assistants on the Site at all times during progress of the Work and such persons shall be satisfactory to the Project Officer or designee. The superintendent shall not be changed except on the Project Officer or designee's determination that the superintendent is no longer satisfactory or except with the consent of the Project Officer or designee where the superintendent proves to be unsatisfactory to the Contractor or ceases to be in the Contractor's employment. If requested by the County, the superintendent must be replaced with 15 days of the Project Officer's written notice. The superintendent shall represent the Contractor and all directions given to him shall be as binding as if given to the Contractor. The Contractor shall at all times enforce strict discipline and good order among the workers performing under this Contract, and shall not employ on the Work any person not reasonably proficient in the Work assigned. Persons permitted to perform Work under Contractor, or any subcontractor, or sub-subcontractor, shall meet all employment eligibility, safety training, security or drug/alcohol testing requirements required by law or by the County. Any person not complying with all such requirements shall be immediately removed from the Site.

10. DRUG-FREE POLICY

The Contractor is responsible for ensuring that the Site remains a drug-free site. Contractor will require that employees undergo random drug/alcohol screening on a quarterly interval. Any employee who fails the test must be removed from the Site

immediately. Random screening shall be performed by a third party licensed to do so in the Commonwealth of Virginia. The Contractor shall provide its random testing policy and schedule to the Project Officer upon request. The Contractor will include this provision in every subcontract relating to this Contract. Any infraction by an employee of the Drug-Free policy shall be reported to the Project Officer within 24 hours.

11. LANDS BY COUNTY

The County shall provide access to the lands shown on the Drawings upon which the Work under the Contract is to be performed and to be used for rights of way and for access. In case all the lands, rights-of-way or easements have not been obtained as herein contemplated before construction begins, then the Contractor shall begin its Work on such lands and rights-of-way that the County has acquired access to. No additional time or compensation shall be awarded to the Contractor for modifying Work location and sequence provided other locations are available for work.

Contractor shall verify the acquisition of all off-site easements and Rights-of-Way prior to the start of off-site construction. Restore all off-site easements to the conditions existing prior to the start of work.

12. LANDS BY CONTRACTOR

If the Contractor requires additional land or lands for temporary construction facilities and for storage of materials and equipment other than the areas available on the site or right-of-way, or as otherwise furnished by the County, then the Contractor shall provide such other lands and access thereto entirely at the Contractor's own expense and without liability to the County. The Contractor shall not enter upon private property for any purpose without prior written permission of all of the persons and entities who own the property. The Contractor shall provide copies of all agreements to the County and shall include language in the agreement indemnifying and holding the County harmless for any damages, repairs, restoration or fees associated with the use of the property. Upon termination of the agreement, the Contractor shall provide to the County a fully executed release from the property owner.

13. PROTECTION OF WORKAND PROPERTY

- a. The Contractor shall continuously maintain and protect all of its Work from damage and shall protect the County's property from damage or loss arising in connection with this Contract until Substantial Completion. After Substantial Completion, the maintenance or protection of any incomplete or remedial Work identified on the punch list that requires maintenance or protection in order to allow for the final completion and acceptance of such Work shall be the responsibility of the Contractor until Final Completion. The Contractor shall make good any such damage or loss, except such as may be caused by agents or employees of the County. Failure to adequately protect the Work shall not be grounds for additional compensation for any maintenance and/or repairs to such Work.

- b. The Contractor shall not place upon the Work, or any part thereof, any loads which are not consistent with the design strength of that portion of the Work.
- c. The Contractor shall be responsible for the preservation of all public and private property, trees, monuments, etc., along and adjacent to the street and/or right-of-way, and shall use every precaution to prevent damage to pipes, conduits and other underground structures, curbs, pavements, etc., except those to be removed or abandoned in place and shall protect carefully from disturbance or damage all monuments and property marks until an authorized agent has witnessed or otherwise referenced their location and shall not remove them until directed. Any damage which occurs by reason of the operations under this Contract, whether shown or not on the approved construction plans, shall be completely repaired or replaced to the County's satisfaction by the Contractor at the Contractor's expense.
- d. Prior to commencing construction activity at the Site, the Contractor shall videotape the Site and an additional Fifty (50) feet outside the perimeter of the Site. Contractor shall submit a copy of high resolution digital recording on a DVD or flash drive to the County. The recording shall be stable, continuous, and contain all items within the limits of Work. Submission of the DVD to the County shall be a condition precedent to any obligation of the County to consider an Application for Payment. The DVD shall be the property of the County, and the County shall be permitted to reproduce such DVD's and use the same for any purpose without limitation or claim of ownership or compensation from any party. Contractor shall incorporate the cost of the preconstruction survey in the bid amount or the unit prices of the bid items, as applicable. No additional payment will be made by the County.
- e. The Contractor shall shore, brace, underpin, secure, and protect, as may be necessary, all foundations and other parts of existing structures adjacent to, adjoining, and in the vicinity of the site that may be affected in any way by excavations or other operations connected with the Work required under this Contract. The Contractor shall be responsible for giving any and all required notices to owners or occupants of any adjoining or adjacent property or other relevant parties before commencement of any work. Contractor shall provide all engineering (signed and sealed) for items listed in this section per the Specifications. The Contractor shall indemnify and hold the County harmless from any damages on account of settlements or loss of all damages for which the County may become liable in consequence of such injury or damage to adjoining and adjacent structures and their premises.
- f. In an emergency affecting the safety of life or of the Work, or of adjoining property, the Contractor, without special instruction or

authorization from the Project Officer or designee, or the County, is hereby permitted to act, at the Contractor's discretion, to prevent such threatened loss or injury, and the Contractor shall so act without appeal, if so instructed or authorized.

14. SEPARATE CONTRACTS

- a. The County reserves the right to let other contracts in connection with this Project. The Contractor shall afford other contractors reasonable access to the Project including storage of their materials and the execution of their work, and shall properly connect and coordinate its Work with the Work of other such contractors.
- b. If any part of the Contractor's Work depends, for proper execution or results, upon the Work of any other contractor, the Contractor shall inspect and promptly report to the Project Officer or designee any defects in such Work that renders it unsuitable for such proper execution and results. The Contractor's failure to so inspect and report shall constitute an acceptance of the other contractor's Work as fit and proper for the reception of the Contractor's work, except as to defects which may develop in other contractor's Work after its execution.
- c. If the Contractor or any of the Contractor's subcontractors or employees cause loss or damage to any separate contractor on the Work, the Contractor agrees to settle or make every effort to settle or compromise with such separate contractor. If such separate contractor sues the County on account of any loss so sustained, the County shall notify the Contractor, who shall indemnify and save the County harmless against any expense, claim or judgment arising therefrom, including reasonable attorney's fees.
- d. In case of a dispute arising between two or more separate contractors engaged on adjacent Work as to the respective rights of each under their respective contracts, the Project Officer shall determine the rights of the parties.

15. SUBCONTRACTS

- a. Unless otherwise specified, the Contractor shall, within Fifteen (15) calendar days after the execution of the Contract by the County, provide to the Project Officer or designee, in writing, the names of all subcontractors proposed for the principal parts of the Work and for such others as requested by the Project Officer or designee, and shall not employ any subcontractors that the Project Officer or designee may object to as incompetent or unfit after an appropriate determination of the subcontractor's ability. No proposed subcontractor will be disapproved except for cause.

- b. The Contractor shall make no substitutions for any subcontractor previously selected/approved unless first submitted to the County for approval.
- c. The Contractor shall be as fully responsible to the County for the acts and omissions of the Contractor's subcontractors as the Contractor is for the acts and omissions of persons directly employed by the Contractor.
- d. The Contractor shall cause appropriate provisions to be inserted in all subcontracts relative to the Work to bind subcontractors to the Contractor by the terms of the General Conditions of the Contract, Special Provisions and other Contract Documents comprising the Contract insofar as such documents are applicable to the Work of sub-contractors.
- e. Nothing contained in the Contract shall be construed to create any contractual relation between any subcontractor and the County, nor shall it establish any obligation on the part of the County to pay to, or see to the payment of any sums to any subcontractor. The County will not discuss, negotiate or otherwise engage in any contractual disputes with any subcontractor.
- f. If requested by the County, the Contractor shall replace any subcontractor at no cost to the County within 30 days of the Project Officers written notice or as otherwise specified. No additional time or compensation will be provided in the event a subcontractor is removed due to non-compliance of the requirements outlined within the Contract.

16. ELIMINATED ITEMS

If any item(s) in the Contract are determined to be unnecessary for the proper completion of the Work contracted, the Project Officer or designee may, upon written notice to the Contractor, eliminate such item(s) from the Contract. Payment will not be made for such item(s) so eliminated; except that the Contractor will be compensated for the actual cost of any Work performed and the net cost of materials purchased before the item(s) was eliminated from the Contract, including freight and tax costs, as evidenced by invoice. No additional compensation will be made for overhead or anticipated profit. The County will receive the full unit price credit for Work eliminated prior to production or installation.

17. COUNTY ORDINANCES

The Contractor shall comply with all applicable County ordinances, including but not limited to: the *Noise Control, Erosion & Sediment Control, Storm Water Management, and Chesapeake Bay Preservation ordinances (Chapters 15, 57, 60, and 61 of the County Code)*.

D. MATERIALS AND WORKMANSHIP

1. MATERIALS FURNISHED BY THE CONTRACTOR

Unless otherwise specified, all materials and equipment incorporated in the Work under the Contract shall be new. All Work shall be accomplished by persons qualified in the respective trades.

2. IBC AND VUSBC REQUIREMENTS

The Contractor certifies that all material supplied or used under this Contract meets all current International Building Code (IBC) requirements and the requirements of the Virginia Uniform Statewide Building Code (VUSBC); and further certifies that, if the material delivered or used in the performance of the Work is found to be deficient in any of the applicable state or national code requirements, all costs necessary to bring the material into compliance with the requirements shall be borne by the Contractor. The County shall be entitled to offset such costs against any sums owed by the County to the Contractor under this Contract.

3. ADA COMPLIANCE

The Contractor shall ensure that all Work performed under this Agreement is completed in accordance with the Contract Documents, including Work intended to meet the accessibility requirements of the Americans with Disabilities Act (ADA), and any other applicable regulations and standards.

The Contractor is not required to ascertain whether the Contract Documents meet ADA design standards and guidelines, or other applicable regulations and standards. However, should the Contractor discover any non-conformity with such requirements, the Contractor shall immediately inform the County and its design consultant, if applicable, to allow for corrective action.

The Contractor shall defend and hold the County harmless from any expense or liability arising from the Contractor's non-compliance in meeting its obligations herein. The Contractor shall be responsible for all costs related to permitting delays, redesign, corrective Work, and litigation relating to such non-compliance.

Neither the Arlington County Inspection Services Division, nor any County staff and/or their third-party inspection services, are responsible for inspecting the Work to ensure it is completed in accordance with Contract Documents, the ADA, or other applicable requirements.

4. MANUFACTURER'S DIRECTIONS

Manufactured articles, material, and equipment shall be applied, installed, connected, erected, used, cleaned, and conditioned in accordance with the manufacturer's directions as accepted by the Project Officer or designee, unless herein specified to the contrary.

5. WARRANTY

All material provided to the County shall be fully guaranteed by the Contractor against manufacturing defects within the period of the manufacturer's standard warranty. Such

defects shall be corrected by the Contractor at no expense to the County. The Contractor shall provide all manufacturers' warranties to the Project Officer by the date of Final Completion.

All Work is guaranteed by the Contractor against defects resulting from the use of inferior or faulty materials. The Contractor warrants that the Work will conform to the requirements of the Contract Documents and will be free from defects or inferior or faulty workmanship, or Work not in accordance with the Contract Documents for one (1) year from the date of Substantial Completion or as set forth in the Specifications of the Work by the County in addition to and irrespective of any manufacturer's or supplier's warranty.

No date other than Substantial Completion or as set forth in the Specifications shall govern the effective date of the Warranty, unless that date is agreed upon by the County and the Contractor in advance and in a signed writing.

The Contractor shall promptly correct any defective Work or materials after receipt of a written notice from the County to do so. If the Contractor fails to proceed promptly or use its best efforts and due diligence to complete such compliance as quickly as possible, the County may have the materials or Work corrected and the Contractor and its Sureties shall be liable for all expenses and costs incurred by the County.

Nothing contained in this section shall be construed to establish a period of limitations with respect to other obligations the Contractor may have under this Contract.

6. INSPECTION AND ACCEPTANCE OF MATERIALS

Inspection and acceptance by the County will be at the Worksite in Arlington County, Virginia and within ten (10) calendar days of delivery unless otherwise provided for in the Contract Documents. The County will not inspect, accept, or pay for any materials stored or delivered off-site by the Contractor, except as provided by the Payment for Stored Materials clause of these General Conditions and other requirements of the Contract Documents. The County's right of inspection shall not be deemed to relieve the Contractor of its obligation to ensure that all articles, materials and supplies are consistent with specifications and instructions and are fit for their intended use. The County reserves the right to conduct any tests or inspections it may deem appropriate before acceptance. The Contractor shall be responsible for maintaining all materials and supplies in the condition in which they were accepted until they are used in the work.

The Contractor is to coordinate its Work and request inspections in such a manner as to minimize the cost to the County without impacting the overall schedule of the Project within reason. All costs associated with re-inspection shall be borne by the Contractor.

7. CONTRACTOR'S TITLE TO MATERIALS

No materials or supplies for the Work shall be purchased by the Contractor or any subcontractor subject to any chattel mortgage or under a conditional sale or other agreement by which an interest is retained by the seller. The Contractor warrants that it has good title to, and that it will require all subcontractors to warrant that they have good title to, all materials and supplies for which the Contractor invoices for payment.

The County may request proof of title or payment prior to acceptance of the Contractors invoice.

8. TITLE TO MATERIALS AND WORKCOVERED BY PARTIAL PAYMENTS

All material and Work covered by partial payments made by the County will become the property solely of the County at the time the partial payment is made. However, risk of loss or damage to all items shall be the responsibility of the Contractor until Final Acceptance by the County. This provision will not be construed as relieving the Contractor from having sole responsibility for all materials and Work upon which payments have been made and for the restoration of any damaged Work or replacement or repair at the County's option of any damaged materials. This provision will not be construed as a waiver of the County's right to require fulfillment of all terms of the Agreement, including full rights under the terms of the Warranty provisions of the Agreement, nor shall payment indicate acceptance of the materials or work.

9. CONNECTING WORK

The Contractor shall do all cutting, patching, or digging of the Contractor's Work that may be required to make its several parts come together properly and fit it to receive or be received by Work of other contractors as shown upon or reasonably implied by the Drawings and Specifications for the completed project and shall make good after them as the Project Officer or designee may direct. This Work will be performed in a workmanlike manner utilizing proper care and equipment to achieve proper line and grade. The Contractor shall not endanger any Work by cutting, patching, or digging, or otherwise, and shall not cut or alter the Work of any other contract except with the prior written consent of the Project Officer or designee.

10. REJECTED WORKAND MATERIALS

- a. Any of the Work or materials, goods, or equipment which do not conform to the requirements of the Contract Documents, or are not equal to samples accepted by the Project Officer or designee, or are in any way unsatisfactory or unsuited to the purpose for which they are intended, shall be rejected and replaced immediately so as not to cause delay to the project or Work by others. Any defective work, whether the result of poor workmanship, use of defective materials, damage through carelessness or any other cause, shall be removed and the Work shall be re-executed by the Contractor at the Contractor's expense. The fact that the Project Officer or designee may have previously overlooked such defective Work shall not constitute acceptance of any part of it.
- b. If the Contractor fails to proceed at once with the replacement of rejected material and/or the correction of defective workmanship when notified to do so by the Project Officer or designee, the County may, by contract or otherwise, replace such material or correct such workmanship and charge the cost to the Contractor. This clause applies during the Contract and during any warranty or guarantee period.

- c. The Contractor shall be responsible for managing, addressing within a timely manner, and formally closing out all notices of non-compliance issued by the inspector of record, Arlington County Inspection Services, or the Design Team. The Contractor shall be solely liable for any costs or time associated with the corrective action to address any notices of non-compliance. The Contractor must Work directly with the entity issuing the notice of non-compliance.
- d. If the Project Officer or designee deems it expedient not to require correction of Work which has been damaged or not done in accordance with the Contract, an appropriate adjustment to the Contract Price may be made.

11. PROHIBITION AGAINST ASBESTOS CONTAINING MATERIALS

No goods or equipment provided to the County or construction material installed shall contain asbestos. If a Contractor or supplier provides or installs any goods, equipment, supplies, or materials that contain asbestos in violation of this prohibition, the Contractor shall be responsible for all costs related to the immediate removal and legal disposal of the goods, equipment or materials containing asbestos and replacement with County-approved alternate. The Contractor shall be responsible for all goods, equipment, supplies or materials installed or provided by any of its employees, agents or subcontractors in connection with the Work under this contract. The Contractor shall also reimburse to the County all costs of such goods, equipment, supplies or materials installed if not corrected by the Contractor.

E. LEGAL RESPONSIBILITY AND PUBLIC SAFETY

1. SITE INVESTIGATION AND CONDITIONS AFFECTING THE WORK

The Contractor acknowledges that it has taken steps reasonably necessary to ascertain the nature and locations of the Work of the Contract, and that it has investigated and satisfied itself as to the general and local conditions and factors which can affect the Work or its cost, including but not limited to:

- a. conditions bearing upon transportation, disposal, handling, and storage of materials;
- b. the availability of labor, water, electric power, and roads;
- c. uncertainties of weather, river stages, tides, or similar physical conditions at the site;
- d. the information and conditions of the ground; and
- e. the character of equipment and facilities needed before and during Work performance.

The Contractor, by executing the Contract, represents that it has reviewed and understands the Contract Documents and has notified the County of and obtained clarification of any discrepancies which have become apparent during the bidding period. During the Contract, the Contractor must promptly notify the County in writing of any apparent errors, inconsistencies, omissions, ambiguities, construction impracticalities or code violations discovered as a result of the Contractor's review of the Contract Documents including any differences between actual and indicated

dimensions, locations and descriptions, and must give the County timely notice in writing of same and of any corrections, clarifications, additional Drawings or Specifications, or other information required to define the Work in greater detail or to permit the proper progress of the Work. The Contractor must provide similar notice with respect to any variance between its review of the Site and physical data and Site conditions observed. If the Contractor performs any Work involving an apparent error, inconsistency, ambiguity, construction impracticality, omission or code violation in the Contract Documents of which the Contractor is aware, or which could reasonably have been discovered, without prompt written notice to the County and request for correction, clarification or additional information, as appropriate, the Contractor does so at its own risk and expense and all related claims are specifically waived.

The Contractor also acknowledges that it has satisfied itself as to the character, quality, and quantity of surface and subsurface materials or obstacles to be encountered insofar as this information is reasonably ascertainable from an inspection of the site, including all exploratory Work done by the County, as well as from the drawings and specifications made a part of this Contract. Unless otherwise specified, all existing structures, materials and obstructions that interfere with the new construction shall be removed and disposed of as part of this Contract. Any failure of the Contractor to take the actions described and acknowledged in this paragraph will not relieve the Contractor from responsibility for estimating properly the difficulty and cost of successfully performing the Work without additional expense to the County.

The locations of existing utilities, including underground utilities, which may affect the Work, are indicated on the drawings or in the specifications insofar as their existence and location were known at the time of preparation of the drawings. However, nothing in these drawings or specifications shall be construed as a guarantee that such utilities are in the location indicated or that they actually exist, or that other utilities are not within the area of the operations. The Contractor shall make all necessary investigations to determine the existence and locations of such utilities. Should uncharted or incorrectly charted utilities be encountered during performance of the Work, notify the Project Officer or designee immediately for instructions. The Contractor will be held responsible for any damage to and maintenance and protection of existing utilities and structures, of both public and private ownership. However, if it is determined that such existing utility lines or structures require relocation or reconstruction or any other Work beyond normal protection, then such additional Work will be ordered under the terms of the clause entitled "Changes in Work." At all times, cooperate with the County and utility companies to keep utility services and facilities in operation.

The County assumes no responsibility for any conclusions or interpretations made by the Contractor based on the information made available by the County. The County assumes no responsibility for any understanding reached or representation made concerning conditions which can affect the Work by any of its officers or agents before the execution of this Contract, unless that understanding or representation is expressly stated in this Contract.

2. PUBLIC CONVENIENCE

The Contractor shall at all times so conduct its Work as to ensure the least possible obstruction to traffic (vehicular, bicycle and pedestrian) and inconvenience to the general public, County employees, and the residents in the vicinity of the Work. Traffic shall be maintained in accordance with the approved MOT plan. No road, street or sidewalk shall be closed to the public except with the permission of the Project Officer or designee and or proper governmental authority. Fire hydrants on or adjacent to the Work shall be kept accessible to firefighting equipment at all times. Temporary provisions shall be made by the Contractor and included in the cost of the Work to ensure the use of sidewalks, trails, and transit facilities compliant with all applicable ADA and other regulations, as well as the proper functioning of all gutters, drainage inlets, drainage ditches, and irrigation ditches, which shall not be obstructed except as approved by the Project Officer or designee.

3. SAFETY AND ACCIDENT PREVENTION

The Contractor shall comply with, and ensure that the Contractor's employees and subcontractors comply with, all current applicable local, state and federal policies, regulations and standards relating to safety and health, including, by way of illustration and not limitation, the U.S. Department of Labor's Occupational Safety and Hazard Administration (OSHA) Construction Industry Regulations, the standards of the Virginia Occupational Safety and Health program of the Department of Labor and Industry for General Industry and for the Construction Industry, the Federal Environmental Protection Agency Standards and the applicable standards of the Virginia Department of Environmental Quality.

The Contractor shall provide, or cause to be provided, all technical expertise, qualified personnel, equipment, tools and material to safely accomplish the Work specified to be performed by the Contractor and subcontractor(s).

The Contractor shall identify to the County Project Officer at least one on-site person who is the Contractor's competent, qualified, and authorized safety officer on the worksite and who is, by training or experience, familiar with and trained in policies, regulations and standards applicable to the Work being performed. The competent, qualified and authorized person must be capable of identifying existing and predictable hazards in the surroundings or working conditions which are unsanitary, hazardous or dangerous to employees, shall be capable of ensuring that applicable safety regulations are complied with, and shall have the authority and responsibility to take prompt corrective measures, which may include removal of the Contractor's personnel from the Worksite.

The Contractor shall provide to the County, within 7 days of issuance of the Notice to Proceed, a copy of the Contractor's written safety policies and safety procedures applicable to the scope of work. Failure to provide this information within may result in cancellation of the Contract.

The Contractor shall exercise proper precaution at all times for the protection of persons and property and shall be responsible for all injury to persons and damage to property either on or off the site, which occur as a result of the Contractor's prosecution of the Work.

The Contractor shall take or cause to be taken such additional safety and health measures as the County may determine to be reasonably necessary. Machinery, equipment, and all hazards shall be guarded in accordance with the safety provisions of the current version of "Manual of Accident Prevention" published by the Associated General Contractors of America, Inc., to the extent that such provisions are not in conflict with applicable local laws. The Contractor is directed to the "Rules and Regulations Governing Construction, Demolition and All Excavation" and adopted by the Safety Codes Commission of Virginia, 1966, or latest edition, covering requirements for shoring, bracing, and sheet piling of trench excavations.

4. HAZARDOUS MATERIALS

Arlington County is subject to the Hazard Communication Standard, 29 CFR §1910.1200 (Standard). The Contractor agrees that it will provide or cause to be provided Safety Data Sheets (SDS) required under the Standard for all hazardous materials supplied to the County or used in the performance of the work. Such SDS shall be delivered to the County no later than the time of actual delivery of any hazardous materials to the County or use of such material in the performance of Work under the Contract by the Contractor or its subcontractors, whichever occurs first. Container labeling meeting the requirements of the Standard shall be appropriately affixed to the shipping or internal containers. The County reserves the right to refuse shipments of hazardous materials not appropriately labeled, or when SDS have not been received prior to or at the time of receipt of the shipment for use by the County or for use by the Contractor in the performance of the Contract, or whenever the material is delivered in a manner inconsistent with any applicable law or regulation. Any expenses incurred due to the refusal or rejection of SDS are the responsibility of the Contractor. The Contractor shall comply with all federal, state, and local laws governing the storage, transportation, and use of toxic and hazardous materials. The Contractor shall maintain onsite an up to date SDS binder for all material used and delivered to the Project. The County Project Officer or his designee shall be allowed access to the SDS book at all times.

5. HAZARDOUS WASTE

Hazardous Waste Generator/Hazardous Waste Disposal: The County Board of Arlington County, Virginia and the Contractor shall be listed as Co-generators. The Contractor shall assume all the duties pertaining to the Waste Generator, including signing the Waste Shipment Record ("WSR") and manifest. The Contractor shall supply the County Project Officer with the executed original Owner's Copy of the WSR, as required by applicable regulatory agencies within 35 days from the time the waste was accepted by the initial waste transporter, and prior to request for final payment. A separate WSR shall be submitted for each shipment to the disposal site.

Delayed Waste Shipment Records: The Contractor shall report in writing to the EPA Region III office within 45 days if an executed copy of the WSR is not received from the operator of the disposal site. The report to the EPA regional office shall include a copy of the original WSR and a cover letter signed by the Contractor stating the efforts taken to locate the hazardous waste shipment and the results of those efforts.

Temporary Hazardous Waste Storage Prohibited: The Contractor shall not temporarily store hazardous waste unless pre-approved by the County in writing. If so approved, hazardous waste stored off-site in a temporary facility shall be monitored and records shall be kept on the number of containers, size, and weight. The Contractor shall inform the County when the hazardous waste is to be transported to the final disposal site. The County has the right to inspect the temporary site at any time. The Contractor shall submit copies of all relevant manifests, Waste Shipment Record(s), and landfill receipts to the County Project Officer prior to the request for final payment. All paper work shall be signed by the Contractor and disposal site operator as required.

6. ASBESTOS

Whenever and wherever during the course of performing any Work under this Contract the Contractor discovers the presence of asbestos or suspects that asbestos is present, the Contractor shall stop Work immediately, secure the area, notify the County Project Officer immediately and await positive identification of the suspect material. During the downtime in such a case, the Contractor shall not disturb any surrounding surfaces but shall protect the area with suitable dust covers. Work shall not proceed without an Asbestos-Related Work Authorization executed by the County Asbestos Program Manager.

7. CROSSING UTILITIES

When construction crosses highways, railroads, streets, waterways, or utilities under the jurisdiction of State, County, City, or other public agency, public utility, or private entity, the Contractor shall secure written permission where necessary from the proper authority before executing such new construction. A copy of such written permission must be filed with the County before any Work is started. The Contractor shall be required to furnish a release from the proper authority before Final Acceptance of the Work.

8. OVERHEAD HIGH VOLTAGE LINES SAFETY ACT

If any Work required herein will be performed within ten feet of an overhead high voltage line, the provisions of Virginia Statute 59.1-406, et. seq., "Overhead High Voltage Line Safety Act" (Act) shall apply. The "person or contractor responsible for the Work to be done", as that term is used in the Act, will be interpreted to mean the Contractor. The Contractor shall notify the owner or operator of the high voltage line in the manner prescribed in Section 59.1-411 of the Act in sufficient time prior to the time Work is to be commenced to avoid any delays in the work. The County will not pay for lost time, profits, or permit any extension of the Work for any delays caused by the failure of the Contractor to make such arrangements in a timely manner. All costs for the Work shall be paid by the Contractor. The County shall reimburse the Contractor for the actual reasonable cost paid to the owner or operator of the high voltage line by the Contractor on presentation to the County by the Contractor of original invoices from the

owner or operator of the high voltage line in the same manner as for other Contractor invoices submitted for Work performed. Retention, if applicable to the Contract, shall not be withheld from the payment to the Contractor by the County for this work. No processing, administrative, or other charges above the actual amount charged by the owner or operator of the high voltage line shall be paid to the Contractor by the County.

9. SANITARY PROVISIONS

The Contractor shall provide and maintain such sanitary accommodations for the use of the Contractor's employees and those of its subcontractors as may be necessary to comply with the requirements and regulations of OSHA and of the local and State departments of health.

10. SITE CLEAN-UP AND WASTE DISPOSAL

The Contractor shall frequently remove and properly dispose of all refuse, rubbish, scrap materials, and debris from the site resulting from the Contractor's operations during the performance of this contract. The Contractor shall ensure the Worksite presents a neat and orderly appearance at all times. The Contractor shall isolate any and all dumpsters, trash cans and recycling bins provided for the project from public use until Final Acceptance.

Unless otherwise stated, the Contract Amount and any unit prices shall include all costs and fees for removal and disposal of all waste and debris, whether disposed of at a County site or at any other location.

The Contractor shall remove all surplus material, false work, temporary structures including foundations thereof, and debris resulting from the Contractor's operations at Work completion and before Final Acceptance. The County shall reserve the right to remove the surplus material, false work, temporary structures including foundations and debris. The County will restore the site to a neat, orderly condition if the Contractor fails to do so. The County shall be entitled to offset such cost against any sums owed by the County to the Contractor under this Contract.

11. STORMWATER POLLUTION PREVENTION PLAN (SWPPP)

When the project includes an approved SWPPP, the Contractor shall strictly abide by this plan which includes: a Pollution Prevention (P2) Plan, an Erosion and Sediment Control (E&S) Plan, and a Storm Water Management Plan. If the Contractor proposes to deviate from this approved plan, it shall be the Contractor's responsibility to coordinate and obtain approval from the County Project Officer prior to implementing any changes.

No separate payment shall be made by the County for SWPPP implementation, with the exception of E&S items as specified on the E&S plans or listed as pay items. The Contractor shall not be entitled to any additional payment for changes to the SWPPP which are the result of the Contractor's Work schedule or resource allocation, weather delays, or other factors not controlled by the County.

F. PROGRESS AND COMPLETION OF THE WORK

1. NOTICE TO PROCEED

The Contractor shall be given written Notice to Proceed with the Work. Such Notice to Proceed shall state the date on which the Work is to be commenced, and every calendar day thereafter shall be counted in computing the actual Time for Completion.

2. TIME FOR COMPLETION

It is hereby understood and mutually agreed by and between the Contractor and the County that the Commencement Date, the rate of progress, and the Time for Completion of the Work to be done hereunder are essential conditions of the Contract. The Contractor agrees that the Work shall be started promptly upon receipt of a written Notice to Proceed in accordance with the accepted schedule. The Works shall be prosecuted regularly, diligently, and uninterruptedly at a rate of progress that will ensure full completion of the project within the Time for Completion specified in the Contract Documents.

3. SCHEDULE OF COMPLETION

Unless otherwise specified, the Contractor shall within 10 business days after the Award Date, or prior to the pre-construction meeting, whichever occurs first, submit schedules which show the order in which the Contractor proposes to carry on the Work, with dates for starting and completing the various activities of the Work. The Contractor shall submit an updated schedule monthly with the request for partial payment. Review and acceptance by the County of the Contractor's schedule of completion shall in no way relieve the Contractor of its responsibility to complete the Work within the contract time. If the Work falls behind the schedule, the County may require the Contractor to prepare and submit, at no extra cost to the County, a recovery schedule indicating by what means the Contractor intends to regain compliance with the schedule. The recovery schedule must be submitted to the County for review by the date indicated in the County's written demand.

4. CONDITIONS FOR COMPLETION

- a. **SUBSTANTIAL COMPLETION:** The Work will be considered Substantially Complete when all of the following conditions have been met and accepted by the Project Officer, and a Certificate of Substantial Completion has been issued:
1. The Contractor has provided formal notice that the Work is substantially complete, and the Project Officer has agreed that the condition of the Work warrants a Substantial Completion inspection;
 2. The Contractor has provided a Punch List and that list has been reviewed and approved by the Project Officer. Failure to include an item on the Punch List does not alter the responsibility of the Contractor to complete all Work in accordance with the Contract Documents;

3. Final test reports as required by the Contract and certificates of inspection and approval required for use and occupancy;
 4. Fire Marshal's report, if applicable;
 5. Approval forms and transfer documents for all utilities;
 6. All life safety systems, including fire alarms, visual and audios alarms, fire detectors and fire alarm annunciator system, sprinkler systems, and all mechanical and electrical systems are complete and working in an automatic mode, and the County has been adequately trained in the operation of the systems;
 7. The HVAC system Testing and Balancing Report and build air quality test results as required for LEED certification have been accepted by the Project Officer;
 8. Operation and Maintenance Manuals have been submitted for review;
 9. All documents and verification of training required in accordance with any Commissioning Plan;
 10. Mark-ups of construction drawings showing the Record or "Record" condition have been submitted for review and approval by the Project Officer;
 12. Entrances and egress pathways have been constructed and can remain clear of construction activities;
 13. A Certificate of Occupancy has been issued for the space by the County's Inspection Services Division;
 14. All Commissioning has performed and completed to the satisfaction of the Project Officer; and
 15. Schedule to complete the Punch List and value of Work not yet complete.
- b. Upon the Contractor providing notice that the Work is substantially complete, the Project Officer or designee will invite all relevant parties to perform an inspection of the Work, and any noted deficiencies or incomplete items not indicated on the Contractor's punch list will be added. All punch list items, whether generated by the Contractor or any other party on behalf of the County, shall be completed within thirty (30) days of the date of Substantial Completion, unless otherwise agreed to by the County due to seasonal or other extenuating circumstances.

c. FINAL COMPLETION: The Work will be considered Finally Complete when all of the following conditions have been met and accepted and a Final Completion Notice has been issued by the Project Officer:

1. The Contractor has provided formal notice that the Work is complete, and the Project Officer has agreed that the condition of the Work warrants a Final Completion inspection;
2. All construction deficiencies and punch list items have been closed and all construction deficiencies corrected and accepted by the Project Officer;
3. All spare parts and attic stock have been delivered, stored in an orderly manner in a space designated by the Project Officer and a complete inventory list has been verified and accepted by the Project Officer;
4. All warranties and manufacturer certificates and contact information for parties providing warranties have been delivered and accepted by the Project Officer;
5. All final Operating and Maintenance manuals have been delivered and approved and accepted by the Project Officer;
6. All final Record Drawings in .pdf format on a CD delivered and accepted by the Project Officer;
7. All commissioning has been completed and any open construction items in the commissioning agent's report have been closed and accepted by the Project Officer; and
8. All LEED documents and submittals, if applicable, to be provided by the Contractor or sub-contractors have been submitted and accepted by the Project Officer.

5. USE OF COMPLETED PORTIONS

The County shall have the right to take possession of and use any completed or partially completed portions of the Work, notwithstanding that the time for completing the entire Work or such portions may not have expired; but taking such possession and use shall not be deemed an acceptance of any Work not done in accordance with the Contract Documents. If the Contractor claims that such prior use increases the cost or delays, the completion of remaining work, or causes refinishing of completed work, the Contractor may submit a claim for compensation or extension of time, or both.

G. MEASUREMENT AND PAYMENT

1. PAYMENTS TO CONTRACTOR

The County will make partial payments, less retainage, to the Contractor monthly on the basis of the Contractor's written estimate of the Work performed during the preceding calendar month as approved by the Project Officer or designee.

The Contractor's application for payment shall indicate the amount of Work completed to date in a format consistent with the accepted bid and as indicated below:

- a. Lump Sum: For lump sum contracts, the Contractor shall provide to the Project Officer a Schedule of Values, and the application for payment will reflect the Schedule of Values and the amount of Work completed in those units.

For contracts that include multiple lump sum line items, the application for payment shall reflect the percentage of Work completed for each lump sum item. If requested by the Project Officer, the Contractor shall provide a Schedule of Values for each lump sum line item in the contract.

- b. Unit Price: The schedule of unit prices in the accepted bid shall be used as the basis for preparing the estimates, and each partial payment shall represent the total value of all units of Work completed, computed at the unit prices stated in the Contract, less the aggregate of previous payments.

At the discretion of the Project Officer, payments may alternatively be based on actual quantities and site measurements taken in the field by County staff using the Contract Unit Prices.

If Stipulated Price Items are included in the contract, Work on such Stipulated Price Items shall be carried out only upon written order by the Project Officer. The payment for a Stipulated Price Item shall be made by the County to the Contractor at the related unit price specified in the 'Stipulated Price Items' section of the Bid Form on the same basis as the payment for any other regular Bid Item.

In addition to the amount of Work completed to date, the application for payment shall indicate the aggregate of all previous payments for each line item, the retainage previously withheld, and the total payment requested this period.

The Contractor's application for payment will not be reviewed or processed unless an updated schedule is attached. The pay application shall also contain a certification by the Contractor that due and payable amounts have been paid by the Contractor, including payments to subcontractors, for Work which previous payment was received by the Contractor from the County.

2. PAYMENT FOR STORED MATERIALS

When requested in writing by the Contractor, payment allowances may be made for material secured for use on the Project and secured at the project site. Such payments

will only be made for materials scheduled for incorporation into the Work within sixty (60) days.

Payment for materials stored offsite may be considered at the discretion of the Project Officer. Any such request shall be made in writing, and the Contractor shall provide photographs of materials stored offsite, bills of sale, and proof of insurance on the premises at which off-site materials are stored with the application for payment. Payment for stored materials may also be subject to additional requirements contained elsewhere in the Contract Documents.

3. PAYMENTS WITHHELD

The Project Officer or designee may withhold or, on account of subsequently discovered evidence, nullify the whole or a part of any certificate for payment to the extent necessary to protect the County from loss on account of defective Work not remedied or withhold payment for violation of any contract term or condition not remedied after sufficient notice given to the Contractor.

Any such withholding shall not result in any liability to the Contractor for damages.

4. COUNTY ORDERED CHANGES IN WORK

The County, without invalidating the Contract, may order extra Work or make changes by addition, deletion or revision in the Work, with the total Contract Amount being adjusted accordingly if applicable. Any change that will increase the Contract Amount more than 10% will require notice to sureties and require that Performance and Payment Bonds be increased by the Contractor. The increased Performance and Payment Bonds must be sent to the County's Office of the Purchasing Agent within 15 calendar days of the County's approval of such change. All such Work shall be executed under the conditions of the original Contract, except that modification of the Time for Completion caused thereby shall be made at the time of approving such change.

a. The Project Officer or designee shall have authority to make minor changes in the Work by verbal order when such changes do not involve extra cost and are not inconsistent with the purpose of the project. Otherwise, except in an emergency endangering life or property, no extra Work or change shall be made unless in pursuance of a written Construction Change Directive or Change Order and no claim for an addition to the Contract Amount or Contract Time shall be valid unless so ordered.

b. The Contractor shall review any County requested or directed change and shall respond in writing within 14 days after receipt of the proposed change stating the effect of the proposed change upon Contractor's work, including any increase or decrease in Contract time and price. The Contractor shall furnish the County an itemized breakdown of the quantities and prices used in computing the proposed change. The Contractor shall also furnish any sketches, drawings, and or pictures to properly explain the change or impact to the Project Officer. It is the sole responsibility of the Contractor to provide adequate change order backup to satisfy the Project Officer.

- c. The value of any such extra Work or change shall be proposed by the Contractor in one or more of the following ways: (a) by estimate in a lump sum; (b) by cost and fixed fee; (c) by unit price additions or deletions of quantities stated in the unit price contract; or (d) by any other method permitted under the Arlington County Purchasing Resolution. The Project Officer will determine the method appropriate based on the nature of the changes.
- d. If none of the aforementioned methods is agreed upon the Contractor shall proceed with the Work without delay under force account, provided the Contractor receives a Construction Change Directive. In such case, the Contractor shall keep and present in such form as the Project Officer or designee may direct, a correct account of the cost, together with vouchers. The Project Officer or designee shall be permitted to verify such records on a daily basis and may require such additional records as are necessary to determine the cost of the change to the Work. The Project Officer or designee shall certify to the amount due to the Contractor, including a reasonable lump sum allowance for overhead and profit. A complete accounting of the extra cost shall be made within 14 days after completion of the Work involved in the claim. Refer to Paragraph G.5, *Force Account Work*, below for a description of allowable costs when Work is performed under force account.
- e. A cost proposal for a change in the Work shall provide a complete breakdown itemizing the estimated quantities and costs of labor, materials, and equipment (base cost) required in addition to any markup used. The allowable percentage markups for overhead and profit for a non-force account change to the Work performed by the Contractor's own forces or performed by the Subcontractor shall be negotiated based on the nature, size, and complexity of the Work involved but shall not exceed the percentages for each category listed below.
 - 1) Subcontractor's markup for overhead and profit for the Work it performs in a change to the Work shall be a maximum of Fifteen Percent (15%).
 - 2) Contractor's markup for overhead and profit on the Subcontractor's base cost in a change to the Work shall be a maximum of ten percent (10%).
 - 3) Contractor's markup for overhead and profit (including bonds and insurance) for Work it performs in a change to the Work shall be a maximum of fifteen percent 15%.
 - 4) The markup for overhead and profit of a sub-subcontractor at any tier on a change to the Work it performs shall be a maximum of fifteen percent (15%). The Contractor and all intervening tiers of subcontractors' markup on such sub-subcontractor's base cost in the change to the Work shall not exceed a total of Ten Percent (10%).

- f. Base Cost is defined as the total of labor, material, and equipment costs, it does not include markup for overhead and profit. The labor costs include only the costs of employees directly constructing or installing the change in the Work and exclude the costs of employees coordinating or managing the work.
- g. The allowable percentage markups for overhead and profit stated above shall compensate the Contractor, subcontractor, and sub-subcontractor for all other costs associated with or relating to the change to the Work including by way of illustration and not limitation, general conditions, supervision, field engineering, coordination, insurance, bond(s), use of small tools, incidental job costs, and all other general and administrative home and field office expenses.
- h. Allowable costs for changes in the Work shall not include home office expenses including payroll costs for the Contractor's officers, executives, administrators, project managers, estimators, clerk's timekeepers, and other administrative personnel employed by the Contractor, whether at the Site or in the Contractor's principal or branch office for general administration of the Work. These costs are deemed overhead included in the percentage markups in Subsection (e) above.
- i. If the change to the Work also changes the Time for Completion by adding days to perform the Work, an itemized accounting of the following Site direct overhead expenses for the change to the time may be considered as allowable costs for compensation in addition to the base cost indicated above:
 - 1) site superintendent's pro-rata salary
 - 2) temporary site office trailer expense
 - 3) temporary site utilities including basic telephone service, electricity, heat, water, and sanitary/toilet facilities.

All other direct and indirect overhead expenses are considered covered by and included in Subsection (e) markups above. In no case shall subcontractor extended overhead be submitted or considered. The County does not have a direct contractual relationship with any subcontractor or supplier and therefore will not direct, discuss or negotiate with subcontractors employed by the Contractor.

- j. If Contractor requests an extension to the Time for Completion due to changes in the Work it must provide to the Project Officer adequate documentation substantiating its entitlement for the time extension. The documentation must demonstrate an anticipated actual increase in the time required to complete the Work beyond that allowed by the Contract as adjusted by prior changes to the Work, not just an increase or decrease in the time needed to complete a portion of the total Work. In the event a Critical Path Method (CPM) schedule is required by the Contract, no extension to the Time for Completion shall be granted unless the additional or change to the Work increases the length of the critical path beyond the Time for Completion as demonstrated on the approved CPM schedule or bar chart schedule. Any Float belongs to Arlington County. A

written statement in addition to a CPM analysis shall be prepared explaining how no other sequence of Work activities could have been performed to decrease the impact or eliminate the impact altogether. If requested by the Project Officer the Contractor must provide alternate documentation detailing the claim to the County's satisfaction.

5. FORCE ACCOUNT WORK

A Force Account may be used at the County's discretion and only when either 1) agreement on the valuation of a change cannot be made using the methods described in the preceding paragraph, *County Ordered Changes in the Work*, or 2) the County cannot firmly establish an applicable and acceptable estimate for the cost of the Work because the level of effort necessary to perform and complete the Work cannot be reasonably estimated or anticipated but can only be determined by performing the work. Because of the significant burden on the County to monitor and control the work, Force Account Work is not a preferred method, and it shall be the responsibility of the Contractor to provide all necessary documentation and justification of costs. The rates for labor, equipment and materials to be used in cases of Work performed on a force account basis will be compensated as documented below. No costs other than those explicitly listed below shall be allowed:

- a. Labor: Before any Force Account Work begins, the Contractor shall submit for approval to the Project Officer the proposed hourly rates and associated labor costs (benefits and payroll burden) for all laborers and forepersons to be engaged in the work. The number of laborers and forepersons engaged in the Work will be subject to regulation by the Project Officer and shall not exceed the number that the Project officer deems most practical and economical for the work. For all labor and forepersons in direct charge of the force account work, excluding general superintendence, compensation will be as follows:
 - 1) Certified Pay Rate: The Contractor will receive the actual rate of wage or scale as set forth in his most recent payroll for each classification of laborers, and forepersons who are in direct charge of the specific operation. The time allowed for payment will be the number of hours such workers are actually engaged in the work. If overtime Work is authorized by the County, payment will be at the normal overtime rate set forth in the Contractor's most recent payroll.
 - 2) Benefits: The Contractor will be entitled to receive the actual cost for any fringe benefits that are regularly provided to the classes of laborers and forepersons engaged in the Work and that are not included in the certified pay rate.
 - 3) Payroll Burden: The Contractor will be entitled to receive the actual cost for all costs associated with required payroll taxes and payroll benefits not covered in 2) above, including:
 - Social Security Tax
 - Medicare Tax

- Unemployment Tax
 - Worker's Compensation Insurance
 - Contractor's Public Liability Insurance
 - Contractor's Property Damage Liability Insurance
- 4) If the Contractor is unable to provide the necessary documentation for Benefits and Payroll Burden as identified above, the Contractor will be entitled to an additive of Twenty Percent (20%) of the Certified Hourly Pay Rate as full and final compensation for Benefits and Payroll Burdens
- 5) Overhead and Profit: The Contractor will be entitled to an additive of 10% on all properly documented and approved costs established in paragraphs 1), 2), 3), and 4) above for all administrative, overhead, and profit associated with labor costs.
- 6) Subsistence and lodging allowances may be allowed by the Project Officer at the actual and documented costs for lodging and meals if the following conditions are met and the applicable rates and authorization for such costs are established prior to beginning the work. No additives for overhead, administrative, profit, or any other costs will be permitted for subsistence and lodging.
- i. The specific Force Account Work is outside the scope of the original contract, requires mobilization of a separate crew not intended to be used on the original contract, and the Contractor's base location is more than 50 miles from the Worksite, or
 - ii. Forces which have been working on the Contract will be used for the Force Account Work and have been routinely staying overnight during the life of the project, and the Force Account Work will warrant an extension of the contract time, and the distance from the Contractor's base location to the Worksite is more than 50 miles
- b. Materials: The Contractor will receive the actual cost of materials accepted by the Project Officer that are delivered and used for the Work including taxes, transportation, and handling charges paid by the Contractor, not including labor and equipment rentals as herein set forth, to which 15 percent (15%) of the cost will be added for administration and profit. The Contractor shall make every reasonable effort to take advantage of trade discounts offered by material suppliers. Any discount received shall pass through to the County. Salvageable temporary construction materials will be retained by the County, or their appropriate salvage value shall be credited to the County, at the County's discretion.
- c. Equipment: For all equipment other than small tools, the Contractor will be entitled to rental rates as established herein, and agreed to in writing before the Work is begun. Transportation costs directly attributable to Force Account Work

will be as stated below. Small tools will be considered any equipment which has a new cost of \$1000 or less, and will not be eligible for any compensation. The Contractor shall provide the Project Officer a list of all equipment to be used in the work. For each piece of equipment, the list shall include the serial number; date of manufacture; location from which equipment will be transported; and, for rental equipment, the rental rate and name of the company from which it is rented. The number and types of equipment engaged in the Work will be subject to regulation by the Project Officer as deemed to be the most practical and economical for the work. No compensation will be allowed for equipment which is inoperable due to mechanical failure. Compensation for equipment shall be as follows:

- 1) Hourly Base Equipment Rental Rates (Owned Equipment) – For equipment authorized for use in the Force Account Work that is owned by the Contractor, the Contractor shall be entitled to an Hourly Base Rental Rate as detailed in the following paragraphs. The Hourly Base Rental Rate for Contractor owned equipment will not exceed 1/176 of the monthly rates of the schedule shown in the *Rental Rate Blue Book* modified in accordance with the *Rental Rate Blue Book* rate adjustment tables that are current at the time the force account is authorized. The rates for equipment not listed in the *Rental Rate Blue Book* schedule shall not exceed the hourly rate being paid for such equipment by the Contractor at the time of the force account authorization. In the absence of such rates, prevailing rates being paid in the area where the authorized Work is to be performed shall be used.
- 2) Hourly Base Equipment Rental Rates (Rented Equipment) – If the Contractor does not possess or have readily available equipment necessary for performing the force account Work and such equipment is rented from a source other than a company that is an affiliate of the Contractor, payment will be based on actual invoice rates when the rates are reasonably in line with established rental rates for the equipment in question and are approved by the Project Officer.
- 3) Hourly Operating Rates – Hourly Operating Rates shall be as established in the Blue Book estimated operating cost per hour. This operating cost will be full compensation for fuel, lubricants, repairs, servicing (greasing, fueling, and oiling), small tools, and any and all incidentals. If rental rates for the equipment being used in the Work are not listed in the Blue Book or otherwise readily available, the Hourly Operating Cost will be 15% of the established Hourly Base Rental Rate. If invoices for Rental Equipment include the furnishing of fuel, lubricants, repair, and servicing, then the Contractor will not be entitled to any Hourly Operating costs for that equipment.
- 4) Equipment Usage - Equipment usage will be measured by time in hours of actual time engaged in the performance of the work. The Contractor

shall be entitled to the applicable Hourly Base Equipment Rental Rate and Hourly Operating Rate for all approved Equipment Usage.

- 5) Equipment Standby – Standby time is defined as the period of time equipment authorized for Force Account Work by the Project Officer is available on-site for the Work but is idle for reasons not the fault of the Contractor or normally associated with the efficient and necessary use of that equipment in the overall operation of the Work at hand. Hourly rates for Contractor owned equipment on standby, will be at 50 percent (50%) of the rate paid for equipment performing work. Operating costs will not be allowed for equipment on Standby. When equipment is performing Work less than Forty (40) hours for any given week and is on standby, payment for standby time will be allowed for up to 40 hours, minus hours performing work. Payment for Standby will be allowed only for working days. Payment for Standby will not be made for the time that equipment is on the project in excess of 24 hours prior to its actual performance in the force account work.
- 6) Transporting Costs – When it is necessary to obtain equipment exclusively for Force Account Work from sources beyond the project limits and the Project Officer authorizes the transporting of such equipment to the Project site, the cost of transporting the equipment will be allowed as an expense. Where the transport requires the use for a hauling unit, the allowable expense will consist only of the actual cost incurred for the use of the hauling equipment, or the applicable Blue Book cost, whichever is less. When equipment is transferred under its own power, the allowable Transporting cost shall be 50% of the Hourly Base Equipment Rental Rate.
- 7) Overhead and Profit – The Contractor shall be entitled to an additive of 10% on all appropriate and approved Equipment Rental, Operating, and Transporting costs as defined above.

d. Subcontracting: The Contractor shall receive the cost of Work performed by a subcontractor as determined in (a), (b), and (c) above. In addition, the Contractor will be allowed an allowance per the schedule below for administrative costs and profit.

Total Cost of Sub-contract Work:	Rate Schedule
\$0 - \$10,000	10%
> \$10,000	\$1,000 + 5 % above \$10,000

- e. Other Costs: The Contractor shall not be entitled to any costs associated with Force Account Work other than those specifically identified in this section.
- f. Statements: Payments will not be made for Work performed on a force account basis until the Contractor has furnished the Project Officer duplicate itemized statements of all costs of such Work detailed as follows:

1. Payroll indicating name, classification, date, daily hours, total hours, rate, and extension of each laborer, foreperson
2. Designation, dates, daily hours, total hours, rental rate, and extension for each unit of equipment
3. Quantities of materials, prices, and extensions
4. Transportation of materials
5. Statements shall be accompanied and supported by invoices for all materials used and transportation charges. However, if materials used on the Force Account Work are not specifically purchased for such Work but are taken from the Contractor's stock, then in lieu of the invoices, the Contractor shall furnish an affidavit certifying that such materials were taken from his stock; that the quantity claimed was actually used; and that the price, transportation, and handling claimed represented his actual cost.

6. CLAIMS FOR EXTRA COST

If the Contractor claims that any event will give rise to a claim for an increase in the Contract Amount or that any instructions from the Project Officer, by drawings or otherwise, will incur him extra cost under the Contract, then, except in emergencies endangering life or property, it shall give the Project Officer written notice thereof no later than three (3) days of the event or instruction. The Contractor thereafter must provide to the Project Officer a full cost proposal within 14 days detailing the amount of additional compensation claimed, together with the basis therefore and documentation supporting the claimed amount. No such claims shall be valid unless so made. If the Project Officer agrees that such event or instructions involve extra cost to the Contractor, any additional compensation will be determined by one of the methods provided in the Changes in Work paragraph of these General Conditions as selected by the Project Officer. All pricing and supporting documentation requirements of the Changes in the Work clause shall apply to claims for extra cost deemed valid under this paragraph.

7. DAMAGES FOR DELAY; EXTENSION OF TIME OTHER THAN FOR WEATHER

The Contractor's relief for any claim for delay which is unreasonable, or caused by the acts and omissions of the County, or due to causes within the County's control, shall be an extension of the Time for Completion and/or the Contractor's direct costs which result from the delay, but only to the extent any damages for delay were actually caused by the County. The Contractor must give the Project Officer written notice of such delay and damages at the time they were incurred but in no event later than three (3) calendar days following the perceived onset of the delay. The Contractor's written notice shall specify the nature the delay claimed by the Contractor, the cause of the delay, and the anticipated impact of the delay on the Contractor's Work schedule. The Contractor thereafter must provide to the Project Officer a full claim within 14 days after cessation of the delay detailing the amount of additional contract time or compensation claimed, together with the basis therefor and documentation supporting the claim.

If the Contractor is entitled to compensation for delay which is unreasonable, or caused by the acts and omissions of the County, or due to causes within the County's control, and where there is no change in the Work, an itemized accounting of the following direct site overhead expenses will be considered as allowable costs to be used in determining the compensation due the Contractor: site superintendent pro-rata salary, temporary site office expense, temporary site facilities, and temporary site utilities including basic telephone service, electricity, heat, water, and sanitary/toilets. A fifteen percent (15%) markup of these expenses will be allowed to compensate the Contractor for home office and other direct or indirect overhead expenses.

If the Contractor submits a claim for damages pursuant to this Section, the Contractor shall be liable to the County for a percentage of all costs incurred by the County in investigating, analyzing, negotiating and litigating the claim, which percentage shall be equal to the percentage of the Contractor's total delay claim that is determined through litigation to be false or to have no basis in law or fact (Virginia Code §2.2-4335).

The Contractor's sole relief on any claims for delay which is reasonable, or not caused by the acts or omissions of the County, or due to causes not within the County's control, or Force Majeure, shall be an extension of the Time for Completion provided the Contractor gave the Project Officer timely written notice at the inception of such delay.

No extension of the Time for Completion or additional compensation, if applicable, will be granted for any delay unless the Contractor demonstrates the claimed delay directly impacts the Critical Path of the accepted CPM schedule or bar chart schedule, whichever is applicable, and any float has been consumed. Claims for compensation for direct costs which result from delay must be substantiated by adequate documentation clearly showing that the Work delayed was on the critical path of the approved CPM schedule or on the sequence of Work on the approved bar chart schedule, as modified, and that the additional costs incurred by the Contractor are directly attributable to the delay in the Work claimed.

8. TIME EXTENSIONS FOR WEATHER

The Contractor's sole relief on any claims for delay which is caused by abnormal weather shall be an extension of the Time for Completion provided the Contractor gave the Project Officer written notice no later than five (5) calendar days after the onset of such delay and provided the weather affected the Critical Path. A fully-documented claim for a time extension under this Section must be submitted no later than thirty (30) calendar days after the cessation of the delay. It shall be the Contractor's responsibility to provide the necessary documentation to satisfy the Project Officer that the weather conditions claimed were encountered, which may include daily reports by the Contractor, copies of notification of weather days to the Project Officer, NOAA backup, and pictures from each day claimed.

The Time for Completion will not be extended due to inclement weather conditions which are normal, as defined below, for Arlington County. The Time for Completion includes an allowance for workdays (based on five (5) day workweek) which according to historical data may not be suitable for construction work. The Contractor may

request extension to the Time for Completion if it can demonstrate unusual and disruptive weather conditions per the requirements below:

- a. That one or more of the Weather Conditions listed below was encountered; and,
- b. The occurrence of the Weather Condition(s) resulted in an inability to prosecute Work which would have otherwise been performed on the day(s) the Weather Condition(s) occurred; and,
- c. The Work which was not able to be completed was on the Critical Path and could not be completed **only** due to the Weather Condition(s) claimed.

The Project Officer will determine the Contractor’s entitlement to an extension of the Time for Completion. A time extension of no more than one (1) day will be granted for one (1) day of lost Work which satisfies the requirements above, regardless of the number of Weather Conditions encountered. The Contractor’s sole relief shall be an extension of the Time for Completion and no claim for an increase in Contract Amount will be allowed.

The Weather Conditions listed below will be the only basis for consideration by the County, based upon the requirements listed above, as an extension of the Time for Completion due to inclement weather or weather-related site conditions.

Weather Condition #1: Unusually Heavy Precipitation - Figure 1 illustrates the anticipated monthly inclement weather due to precipitation (Rain Days). If the number of days with precipitation in excess of 0.10”, as recorded at Washington Reagan National Airport, exceeds the anticipated Rain Days, the Contractor will be entitled to an extension of one (1) day on the Time for Completion for every day in excess of the Rain Days illustrated in Figure 1. The anticipated value of Rain Days for partial months at the beginning and end of the Contract shall be evaluated on a pro-rated basis.

FIGURE 1
Average days with precipitation of 0.1” or more

Jan	Feb	Mar	Apr	May	Jun	Jul	Aug	Sep	Oct	Nov	Dec
7	6	7	6	8	6	7	6	6	5	6	6

Weather days are not exclusive to the individual months that they represent in Figure 1. If weather days are not used in a previous month(s) they can be used to offset weather delays in subsequent months. This will be reviewed on a case by case basis and is subject to reconciliation at the end of the Project.

Condition #2: Temperature – The Contractor may be entitled to an additional day for every day that the recorded high temperature at Washington Reagan National Airport is 32 degrees Fahrenheit or less, that has not already been incurred under Weather Condition #1 above. This condition does not apply to vertical construction as defined by the Arlington County Vertical Construction Standards.

9. RELEASE OF LIENS

The County, before making final payment, shall require the Contractor to furnish a complete release of all liens arising out of this Contract. The Contractor may, if any subcontractor refuses to furnish a release or receipt in full, furnish a bond satisfactory to the County, to indemnify him against any lien. If any lien remains unsatisfied after all payments have been made, the Contractor shall refund to the County all money that the latter may be compelled to pay in discharging such lien. However, the County may make payments in part or in full to the Contractor without requiring the releases or receipts, and the payments so made shall not impair the obligations of any Surety or Sureties on any bond or bonds furnished under this Contract.

10. FINAL PAYMENT

After the Contractor has completed all Work and corrections to the satisfaction of the Project Officer or designee and delivered all maintenance and operating instructions, schedules, quantities, bonds, certificates of inspection maintenance record documents, and other items required as final payment submittal documents, the Contractor may make application for final payment following the procedure for progress payments. The Final Application for Payment shall be accompanied by all documents required in the Contract, including a complete and signed and notarized copy of the Final Payment Release Form as follows:

RELEASE AND REQUEST FOR FINAL PAYMENT

CONTRACT NUMBER: _____ CONTRACTOR NAME: _____

FINAL PAYMENT AMOUNT: _____

The Contractor hereby requests final payment in the amount indicated on the above referenced Contract. The Contractor agrees that its acceptance of final payment releases and forever discharges Arlington County and its officers, employees, servants and agents from any and all actions, claims, demands and liability of whatever nature now existing or which may hereafter arise as a result of or in connection with the above referenced Contract.

The Contractor certifies that all of the debts for labor, materials, and equipment incurred in connection with the above referenced Contract have been fully paid.

AUTHORIZED SIGNATURE DATE: _____

The date of Final Acceptance is the date on which the County issues the final payment for the Work performed.

COMMONWEALTH OF VIRGINIA COUNTY OF ARLINGTON

On this the ____ day of _____, 20__, before me, personally appeared _____, who acknowledged himself/herself to be _____ in the above instrument, and that he/she, as such _____, being authorized so to do, executed the foregoing instrument for the purposes therein contained, by signing his/her name by himself/herself as _____.

IN WITNESS WHEREOF, I hereunto set my hand and official seal.

Notary Public

My Commission Expires: _____

VI. INSURANCE REQUIREMENTS

Review this section carefully with your insurance agent or broker prior to submitting a bid or proposal. See the Insurance Checklist (part of the Bid or Proposal Forms) for specific coverages applicable to this Contract. The term "Contract," as used in this section, shall mean the fully executed Agreement covering the Work entered into between the County and the Contractor.

1. General

- 1.1 The Contractor shall provide insurance as specified in the Insurance Checklist found on the last page of the bid or proposal form.
- 1.2 The Contract with the Contractor will not be executed by the County until the Contractor has obtained, at its own expense, all of the insurance called for hereunder and such insurance has been approved by the County; additionally, the Contractor shall not allow any subcontractor to start Work on any subcontract until all insurance required of the subcontractor has been so obtained and approved by the Contractor. The Contractor shall submit to the County Purchasing Agent copies of all required endorsements and documentation of coverage consistent with the requirements herein or, alternately, at the County's request, certified copies of the required insurance policies in compliance with the insurance requirements. All endorsements and documentation shall state this Contract's number and title.
- 1.3 The Contractor shall require all subcontractors to maintain during the term of this Agreement, Commercial General Liability insurance, Business Automobile Liability insurance, and Workers' Compensation, Employers' Liability insurance, or any other insurance required by the Contract in the same manner and form as specified for the Contractor. The Contractor shall furnish subcontractors' evidence of insurance and copies of endorsements to the County Purchasing Agent immediately upon request by the County and/or prior to the subcontractor's performance of Work related to this Contract.
- 1.4 If there is a material change or reduction in coverage, nonrenewal of any insurance coverage or cancellation of any insurance coverage required by this contract, the Contractor shall notify the Purchasing Agent immediately. It is the Contractor's responsibility to notify the County upon receipt of a notice indicating that the policy will not be renewed or will be materially changed. Any policy on which the Contractor has received notification from an insurer that the policy has or will be cancelled or materially changed or reduced must be immediately replaced with another policy consistent with the terms of this Contract and in such a manner that there is no lapse in coverage, and the County immediately notified of the replacement. Not having the required insurance throughout the Contract Term is considered a material breach of this Contract and grounds for termination. The Contractor shall also obtain an endorsement providing to the County thirty (30) days advance notice of cancellation or nonrenewal (ten days for nonpayment of premium). A copy of that endorsement shall be provided to the County Purchasing Agent prior to the execution of this Contract or any Contract extension thereafter.
- 1.5 No acceptance and/or approval of any insurance by the County shall be construed as relieving or excusing the Contractor, any surety, or any bond, from any liability or obligation imposed under this Agreement.

1.6 Arlington County, and its officers, elected and appointed officials, employees, and agents are to be named as additional insureds under all coverages except Workers' Compensation, Professional Liability, and Automobile Liability, and the endorsement must clearly identify the County as an additional insured permitted to enjoy all the benefits under the applicable policy of insurance. The certified policy, if requested, must so state coverage afforded under this paragraph shall be primary as respects the County, its officers, elected and appointed officials, agents and employees. The following definition of the term "County" applies to all policies issued under the Contract and to all applicable endorsements:

"The County Board of Arlington County and any affiliated or subsidiary Board, Authority, Committee, or Independent Agency (including those newly constituted), provided that such affiliated or subsidiary Board, Authority, Committee, or Independent Agency is either a Body Politic created by the County Board of Arlington County, Virginia, or one in which controlling interest is vested in Arlington County; and Arlington County Constitutional Officers."

1.7 The Contractor shall be responsible for the Work performed under the Contract Documents and every part thereof, and for all materials, tools, equipment, appliances, and property of any description used in connection with the work. The Contractor assumes all risks for direct and indirect damage or injury to the property or persons used or employed on or in connection with the Work contracted for, and of all damage or injury to any person or property wherever located, resulting from any action, omission, commission or operation under the Contract, or in connection in any way whatsoever with the contracted work.

1.8 The insurance coverage required shall remain in force throughout the Contract Term or as otherwise stated in the Contract Documents or these Insurance Requirements. If the Contractor fails to provide acceptable evidence of current insurance within seven (7) days of written notice at any time during the Contract Term, the County shall have the absolute right to terminate the Contract without any further obligation to the Contractor.

1.9 Contractual and other liability insurance provided under this Contract shall not contain a supervision, inspection or engineering services exclusion that would preclude the County from supervising or inspecting the Work as to the end result. The Contractor shall assume all on-the-job responsibilities as to the control of persons directly employed by it and of the subcontractors and any persons employed by the subcontractor.

1.10 If any policy contains a warranty stating that coverage is null and void (or words to that effect) if the Contractor does not comply with the most stringent regulations governing the work, such policy shall be modified so that coverage shall be afforded in all cases except for the Contractor's willful or intentional noncompliance with applicable government regulations.

1.11 All policies shall include the following language: "The insolvency or bankruptcy of the insured or of the insured's estate will not relieve the insurance company of its obligations under this policy."

1.12 All policy forms must "Pay on behalf of" rather than "Indemnify" the insured.

- 1.13 Nothing contained in these Insurance Requirements or the Contract Documents shall be construed as creating any contractual relationship between any subcontractor and the County. The Contractor shall be as fully responsible to the County for the acts and omissions of its subcontractors and of persons employed by them as it is for acts and omissions of persons directly employed by it.
- 1.14 Precaution shall be exercised by the Contractor at all times for the protection of persons, (including employees) and property. All existing structures, utilities, roads, services, trees and shrubbery shall be protected against damage or interruption of service at all times by the Contractor and its subcontractors during the term of the Contract, and the Contractor shall be held responsible for any damage to property occurring by reason of its Work under the Contract.
- 1.15 For any claims related to this work, The Contractor's insurance shall be deemed primary and non-contributory to all other applicable coverage and in particular with respect to Arlington County, its representatives, officials, employees, and agents. Any insurance or self-insurance maintained by Arlington County shall be excess and noncontributory of the Contractor's insurance. The Contractor shall waive its right of subrogation for all insurance claims.
- 1.16 If the Contractor does not meet the insurance requirements set forth by the Contract Documents, alternate insurance coverage or self-insurance, satisfactory to the Purchasing Agent, may be considered. Written requests for consideration of alternate coverages including the Contractor's most recent actuarial report and a copy of its self-insurance resolution to determine the adequacy of the insurance funding must be received by the County Purchasing Agent at least ten (10) working days prior to the date set for receipt of bids or proposals. If the County denies the request for alternate coverages, the specified coverages will be required to be submitted. If the County permits alternate coverage, an amendment to the Insurance Requirements will be prepared and distributed prior to the time and date set for receipt of bids or proposals.
- 1.17 All required insurance coverages must be acquired from insurers authorized to do business in the Commonwealth of Virginia and acceptable to the County. The insurers must also have a policyholders' with a rating of "A-VII" in the latest edition of the A.M. Best Co.'s Insurance Reports, unless the County grants specific approval for an exception, in the same manner as described in 1.16 above.
- 1.18 The Contractor shall be responsible for payment of any deductibles applicable to the coverages.
- 1.19 The Contractor must disclose the amount of any deductible or self-insurance component applicable to the General Liability, Automobile Liability, Professional Liability, Intellectual Property or any other policies, if any. The County reserves the right to request additional information to determine if the Contractor has the financial capacity to meet its obligations under a deductible. Thereafter, at its option, the County may require a lower deductible, funds equal to the deductible be placed in escrow, a certificate of self-insurance, collateral, or other mechanism in the amount of the deductible to ensure additional protection for the County.

2. Contractor's Insurance:

2.1 The Contractor shall purchase the following insurance coverages, including the terms, provisions and limits shown in the Insurance Checklist.

2.1.1 Commercial General Liability - Such Commercial General Liability policy shall include any or all of the following as indicated on the Checklist:

- i. General aggregate limit is to apply per project;
- ii. Premises/Operations;
- iii. Actions of Independent Contractors;
- iv. Products/Completed Operations to be maintained for five (5) years after completion of the Work;
- v. Contractual Liability, including protection for the Contractor from claims arising out of liability assumed under this Contract;
- vi. Personal Injury Liability including, including but not limited to, coverage for offenses related to employment and copyright infringement;
- vii. Explosion, Collapse, or Underground (XCU) hazards.

2.1.2 Business Automobile Liability, including coverage for any owned, hired, or non-owned motor vehicles, Uninsured Motorists coverage, and automobile contractual liability.

2.1.3 Workers' Compensation - statutory benefits as required by Virginia law or the U.S. Longshoremen's and Harbor Workers' Compensation Act, or other laws as required by labor union agreements, including standard Other States coverage; Employers' Liability coverage. The policy shall not contain any provision or definition which would serve to eliminate third party action over claims, including exclusion for bodily injury to an employee of the insured, employees of the premises owner, or employees of the general contractor to which the insured is subcontracted; or employees of the insured's subcontractor.

2.1.4 General Environmental Remediation Projects

In addition to the Insurance Requirements specified in the general provision or elsewhere in the Contract Documents, the Contractor shall not commence Work under this Contract until all insurance as required hereafter has been obtained, and certified copies, naming the County as an additional insured, of such insurance have been submitted and accepted by the Purchasing Agent.

- i. An environmental remediation contractor or subcontractor shall be responsible for purchasing and maintaining Business Automobile Liability

insurance and Workers' Compensation insurance as described in 2.1.2 and 2.1.3.

- ii. Acceptance by Arlington County of insurance submitted by the Contractor does not relieve or decrease in any manner the liability of the Contractor for performance of environmental remediation Work under the Contract.
- iii. The Contractor is responsible for any losses, claims, and costs of any kind, which exceed the Contractor's limits of liability, or which may be outside the coverage scope of the policies. The limits and coverage requirements may be revised at the option of the Arlington County Risk Manager. The requirements outlined shall in no way be construed to limit or eliminate the liability of the Contractor, which arises from performance of Work under the Contract.

2.1.5 Contractors Pollution Liability (CPL) Policy

- i. Minimum liability limits required shall be \$1,000,000 Per Loss and \$2,000,000 Total All Losses, including, but not limited to, property damage, bodily injury, loss of use, and clean-up costs.
- ii. Limits must be dedicated to Work performed under this Contract only, unless prior approval by the Arlington County Risk Manager has been obtained. The policy of insurance shall contain or be endorsed to include the following:
 - a. Pollution coverage as respects asbestos, lead, and PCB's.
 - b. "Covered Operations" designated by the CPL policy must specifically include all Work performed under this contract. (This would include and not be limited to excavation, off-site incineration of soils, demolition, asbestos abatement, drum removal and disposal, in-situ vapor extraction, etc.) and exclusions or limitations affecting Work performed under this contract must be deleted. (i.e., lead, asbestos, pollution, testing, underground storage tanks, radioactive matter, etc.)
 - c. Contractor must comply with all applicable DOT and EPA requirements.
 - d. Premises/Operations.
 - e. Broad form property damage.
 - f. Products/Completed Operations coverage for a minimum of five (5) years after Final Payment.
 - g. Contractual liability coverage in accordance with ISO policy form CG 00 01 11 85. Modifications to the standard provision will not be acceptable if they serve to reduce coverage.
 - h. Cross liability/severability of interest.

- i. The scope of Work and all related activities under this Contract shall be scheduled as “Covered Operations” under this policy.
- j. Coverage is included on behalf of the insured for covered claims arising out of the actions of independent contractors. If insured is utilizing subcontractors, the CPL policy must use “By or On behalf of” language with regards to coverage.
- k. Loading and unloading exclusions must be amended so as to include coverage for mobile equipment and automobiles.

2.1.6 Asbestos and Lead Based Paint Abatement Projects

- i. Minimum Liability Limits shall be \$1,000,000 Per Occurrence and \$2,000,000 Aggregate. Limits must be dedicated to Work performed under this Contract only, unless otherwise approved by the Arlington County Risk Manager. The policy shall be written with a minimum annual aggregate combined single limit for Bodily Injury and Property Damage as shown on the Insurance Checklist. This limit can be inclusive of defense costs.
- ii. The policy of insurance shall contain or be endorsed to include the following:
 - a. Coverage for Asbestos/Lead-Based Paint Abatement operations as described in the contract. Specific lead endorsement evidencing this project must be provided, if applicable.
 - b. Pollution coverage as respects Asbestos/Lead-Based Paint for all phases of the abatement process.
 - c. Transportation coverage for the hauling of ACM/Lead-Based Paint from the project site to the final disposal location, as evidenced by the contractor or applicable waste hauler. Contractor must comply with all applicable D.O.T. regulations.
 - d. Premises/Operations.
 - e. Broad Form Property Damage.
 - f. Products/Completed Operations coverage for a minimum of five (5) years after project completion.
 - g. Contractual Liability coverage in accordance with ISO policy form CG 00 01 11 85. Modifications to the standard provision will not be acceptable if they serve to reduce coverage.
 - h. Cross Liability. Any “Insured vs. Insured” – type language must be deleted or amended to “Named Insured vs. Named Insured.”

- i. The policy shall not exclude Asbestos/Lead Based Paint bodily injury to employees of Arlington County so long as their designated job duties do not require them to be in the regulated asbestos/lead based paint abatement area.
- j. If the policy or any endorsement contains a provision which limits or eliminates bodily injury or property damage coverage based on final air fiber clearance levels, the policy shall be modified so that it is consistent with the clearing level (FCC) and the appropriate analytical testing protocol contained in the project specifications.
- k. Personal Injury.
- l. Independent Contractors.
- m. Hostile fire coverage is to be provided.

2.1.7 Environmental Impairment Liability, including coverage of insureds' on-site clean up, with the following minimum limits of liability:

Bodily Injury and Property	2,000,000 each occurrence
Damage Liability	4,000,000 annual aggregate

The County Board of Arlington County, Virginia, is to be named in Additional Name Insured or a Broad Form Contractual Endorsement may be added to the policy as respects any liability that may arise out of or result from the handling of Work on this Project including specifically but without limitation thereto, the indemnity provisions in the Agreement. Such policies will be endorsed to provide that they are primary to an insurance carried by the County Board of Arlington County, Virginia.

2.1.8 Should any of the Work hereunder involve the cleanup, remediation and/or removal of bio-solids, bio-hazards waste, or any hazardous or toxic materials, trash, debris, refuse, or waste, the Contractor shall provide, or shall require its subcontractor performing the Work to provide, the following coverage in addition to the above requirements:

- a) Environmental Liability and Cleanup Coverage – with limits of not less than \$2,000,000 per occurrence.
- b) Business Automobile Liability – for transportation or regulated and/or hazardous waste, products, or materials with limits of not less than \$1,000,000, per occurrence. Said coverage shall include County as an additional insured and shall include both the MCS-90 and CA 9948 (or equivalent) endorsements, which shall be specifically referenced on the certificate of insurance.

2.2 The Contractor shall take reasonable precautions for the safety of, and shall provide all reasonable protection to prevent damage, injury or loss to, its employees on the job, and others. The Contractor shall comply with all applicable provisions of federal, state and municipal safety laws, insurance requirement's, standard industry practices, the requirements of the operations and this contract, the Contractor, directly through its subcontractors, shall effect and properly maintain at all times, as required by the conditions and progress of the work, necessary safeguards for safety

and protection of the public, including securing areas, posting danger signs, placarding, labeling or posting other forms of warning against hazards.

3. Commercial General or other Liability Insurance - Claims-made Basis:

- 3.1 If Commercial General or other liability insurance purchased by the Contractor has been issued on a claims-made basis, the Contractor must comply with the following additional conditions. The limits of liability and the extensions to be included as described in the Insurance Checklist remain the same. The Contractor must either:
- i. Agree to provide insurance, copies of the endorsement and certified documentation evidencing the above coverages and naming the County as an additional insured for a period of five (5) years after final payment under the Contract. Such documentation shall evidence a retroactive date, no later than the beginning of the Contractors or subcontractors' Work under this Contract, or
 - ii. Purchase an extended (minimum five [5] years) reporting period endorsement for the policy or policies in force during the term of this Contract and evidence the purchase of this extended reporting period endorsement by means of a copy of the endorsement itself. The extended reporting period will begin upon final payment under the Contract.

4. Builder's Risk Insurance

- 4.1 The Contractor shall purchase and maintain builders risk insurance with a limit equal to the initial Contract Amount and any amendments to the Contract which affect the project cost on a replacement cost basis. Builder's risk insurance shall be maintained until Final Payment under the Contract has been made or until no person or entity other than the County has an insurable interest in the covered property, whichever is earlier. The builders risk insurance shall include the County as defined in Section 1.6, Contractor, subcontractors and sub-subcontractors as named insureds.
- 4.2 Insurance shall be on an all-risks policy form including the perils of fire, theft, vandalism, malicious mischief, lightning, wind, force majeure, collapse, and earthquake. Coverage is to apply for demolition occasioned by enforcement of any applicable legal requirements, and Architect's fees. Coverage for the peril of flood shall not be required unless otherwise required in the Contract Documents.
- 4.3 Unless otherwise provided in the Contract Documents, the builders risk insurance shall also cover materials to be incorporated into the project which are stored off the site.
- 4.4 The Contractor shall purchase and maintain Boiler and Machinery insurance, if required by the contract documents or by law, with a limit satisfactory to the County. The Boiler and Machinery insurance shall cover objects during installation and until Final Acceptance by the County. The County shall be included as a named insured.
- 4.5 Any loss under builders risk insurance shall be payable to the County as fiduciary for the insureds, as their interests may appear, subject to any mortgagee clause. The Contractor shall

pay subcontractors their just shares of insurance proceeds received by the Contractor, and by appropriate agreements, written where legally required for validity, shall require subcontractors to make payments to their sub-subcontractors in similar manner. The County, as fiduciary, shall have the right to adjust and settle a loss with insurers.

- 4.6 The insurance company providing the builders risk coverage shall grant permission for the County to partially occupy or use the premises under construction prior to final acceptance without removing or affecting the coverage.

VII. ATTACHMENTS AND FORMS

ATTACHMENT – A

PRICE SCHEDULE

(ISSUED SEPARATELY)

ATTACHMENT B

MASTER TRANSPORTATION PLAN

ATTACHMENT - C

LANE CLOSURES IN NOVA DISTRICT

(ISSUED SEPARATELY)

ATTACHMENT - D

STATE AND FEDERAL ROADS IN ARLINGTON COUNTY, VIRGINIA

ATTACHMENT- E

**ARLINGTON COUNTY, VIRGINIA MATERIALS TESTING SPECIFICATION REFERENCE GUIDE
(8-18-2016)**

ATTACHMENT F

POLYPROPYLENE PIPE DETAIL

(ISSUED SEPARATELY)

ATTACHMENT G

BIODEGRADABLE TREE SHELTER

ATTACHMENT H
POLYPROPYLENE TREE SHELTER

ATTACHMENT I

LIVE STAKES

ATTACHMENT J
SAMPLE PROJECTS

ARLINGTON COUNTY, VIRGINIA
OFFICE OF THE PURCHASING AGENT

INVITATION TO BID NO.19-279-ITB

B I D F O R M

SUBMIT TWO (2) FULLY-COMPLETED AND SIGNED BID FORMS TO THE OFFICE OF THE BID CLERK, SUITE 511, 2100 CLARENDON BLVD., ARLINGTON, VIRGINIA 22201 (ONE FORM SHALL CONTAIN AN ORIGINAL LONGHAND SIGNATURE; THE OTHER SHALL BE A PHOTOCOPY OF THE SIGNED ORIGINAL)

BIDS WILL BE OPENED AT ON JUNE 4, 2019 AT 2:00 P.M. EST

FOR PROVIDING CONSTRUCTION SERVICES IDENTIFIED HEREIN IN ACCORDANCE WITH THE DRAWINGS, SPECIFICATIONS, TERMS AND CONDITIONS OF THIS SOLICITATION

THE UNDERSIGNED UNDERSTANDS AND ACKNOWLEDGES THE FOLLOWING:

THE OFFICIAL, TRUE, AND COMPLETE COPY OF THE SOLICITATION DOCUMENTS, WHICH SHALL INCLUDE ALL ADDENDUMS THERETO, IS THE ELECTRONIC COPY OF THE SOLICITATION DOCUMENTS PROVIDED AT THE COUNTY'S WEBSITE ([HTTP://BUDGET.ARLINGTONVA.US/PURCHASING](http://budget.arlingtonva.us/purchasing)).

EACH BIDDER IS RESPONSIBLE FOR DETERMINING THE ACCURACY AND COMPLETENESS OF ALL SOLICITATION DOCUMENTS THEY RECEIVE, INCLUDING DOCUMENTS OBTAINED FROM THE COUNTY AND DOCUMENTS OBTAINED FROM ALL OTHER SOURCES.

The undersigned certifies that (Bidder Name) _____ is currently registered with the Virginia State Board of Contractors as required by the Code of Virginia. Certificate Number _____ for a Class ____ License was issued on the _____ day of _____, 20 _____. The undersigned further certifies that the registration fee and all renewal fees required under law have been paid. The Contractor agrees to furnish all necessary labor, equipment, materials, and all things necessary to perform the Work as set forth in accordance with the plans and specifications at the following prices: (All prices include provision and installation).

The undersigned acknowledges receipt of the following Addendums:

ADDENDUM A DATE: _____ INITIAL: _____

ADDENDUM B DATE: _____ INITIAL: _____

ADDENDUM C DATE: _____ INITIAL: _____

BIDDER NAME: _____

BID FORM, PAGE 2 OF 6

FURNISHING ALL LABOR, MATERIALS, EQUIPMENT, TRANSPORTATION, INCIDENTALS AND SUPERVISION ON AN ON-CALL BASIS FOR CONSTRUCTION OF WET UTILITIES (STORM/SANITARY/WATER MAINS) AND ASSOCIATED OUTFALL AND STREAM CHANNEL IMPROVEMENT PROJECTS IN ARLINGTON COUNTY.

LIQUIDATED DAMAGES: \$1,428.00 PER DAY

PLEASE COMPLETE THE PRICING SHEET PROVIDED WITH THE BID DOCUMENTS AS ATTACHMENT A TO ITB NO. 19-279-ITB AND SUBMIT IT WITH YOUR BID IN HADRCOPY AS WELL AS A DIGITAL COPY ON USB DRIVE OF A COMPACT DISK

FAILURE TO SUBMIT THE PRICING SHEET WITH THE BID WILL DEEM THE BIDDER NONRESPONSIVE.

MINIMUM BIDDER QUALIFICATIONS

The Contractor shall have three (3) continuous years of on-call services construction contract experience conducting public works infrastructure and wet utilities improvement projects in an urban environment. The Contractor/Subcontractor shall also have three (3) years of continuous on-call services construction contract experience in regenerative stormwater conveyance (RSC), streambank stabilization and stream restoration construction including work in urban environment. The experience shall be work of similar size and scope, construction and re-construction and shall include at least one (1) RSC project.

The Contractor obtained project experience shall consist of the following:

- **State and County streets**
- **Storm sewer pipes and inlets**
- **Water mains**
- **Sanitary sewer pipes and structures**
- **Curbs and gutters**
- **Sidewalks and walkways**
- **Driveway aprons**
- **Pavement markings and signage**
- **Streetscapes**
- **Erosion and sediment control in and adjacent to waterways**
- **Step pool and weir construction**
- **Longitudinal and cross-section channel surveys**
- **Stone stream BMP walls**
- **Bank, floodplain and channel grading**
- **Riffle and pool construction**
- **Bank stabilization, including biostabilization**
- **Riparian planting and restoration**

The Contractor shall provide a list of ten (10) projects completed within the last five (5) years with reference contact information for each project for Bidder qualification verification. Failure to qualify according to the foregoing requirements will result in bid rejection by the Arlington County Purchasing Office.

BID FORM, PAGE 3 OF 6

THE UNDERSIGNED (INITIAL ONE ENTRY) ELECTS____, DOES NOT ELECT____, TO USE THE ESCROW PROCEDURES DESCRIBED IN SECTION 11-56.1 OF THE VIRGINIA PUBLIC PROCUREMENT ACT.

TRADE SECRETS OR PROPRIETARY INFORMATION:

Trade secrets or proprietary information submitted by an Bidder in connection with a procurement transaction shall not be subject to public disclosure under the Virginia Freedom of Information Act. However, Section 4-111 of the Arlington County Purchasing Resolution states that the Bidder must invoke the protection of this section prior to or upon submission of the data or other materials, and must identify the data or other materials to be protected and state the reasons why protection is necessary.

Please mark one:

- () No, the bid I have submitted does not contain any trade secrets and/or proprietary information.

- () Yes, the bid I have submitted does contain trade secrets and/or proprietary information.

If Yes, you must clearly identify below the exact data or other materials to be protected and list all applicable page numbers of the bid containing such data or materials:

State the specific reason(s) why protection is necessary:

If you fail to identify the data or other materials to be protected and state the reasons why protection is necessary in the space provided above, you will not have invoked the protection of Section 4-111 of the Purchasing Resolution. Accordingly, effective upon the award of contract, the bid will be open for public inspection consistent with applicable law.

BIDDER NAME: _____

BID FORM, PAGE 4 OF 6

CERTIFICATION OF NON-COLLUSION: The undersigned certifies that this bid is not the result of, or affected by, any act of collusion with another person (under Virginia Code Section 59.1-68.6 et seq.), engaged in the same line of business or commerce; or any act of fraud punishable under Article 1.1 of the Virginia Governmental Frauds Act (Va. Code §18.2-498.1 et seq.).

CERTIFICATION OF UNDERSTANDING OF THE CONTRACT DOCUMENTS: The undersigned affirms that he has carefully examined all of the Solicitation Documents and that there are no erroneous, contradictory, incomplete or infeasible requirements or directions apparent in the Bid. The undersigned agrees to waive any claims in any way associated with any such erroneous, contradictory, incomplete or infeasible requirements or directions unless such requirements could only reasonably be uncovered during the course of the Work.

CONTACT PERSON AND MAILING ADDRESS FOR DELIVERY OF NOTICES

Provide the name and address of the person designated by the Bidder to receive notices and other communications (Refer to section headed Notices in the Contract Terms and Conditions of this solicitation for further details):

NAME: _____

ADDRESS: _____

E-MAIL: _____

THE PROPER LEGAL NAME OF THE FIRM OR ENTITY SUBMITTING THIS BID MUST BE WRITTEN IN THE SPACE PROVIDED BELOW. THIS BID FORM, AND ALL OTHER DOCUMENTS REQUIRED BY THE INVITATION TO BID TO BE SUBMITTED WITH THIS BID FORM, INCLUDING, BUT NOT LIMITED TO ALL ISSUED ADDENDUMS, MUST BE FULLY AND ACCURATELY COMPLETED AND SIGNED BELOW BY A PERSON AUTHORIZED TO LEGALLY BIND THE BIDDER, OR THE BID MAY BE REJECTED:

AUTHORIZED SIGNATURE: _____

PRINT NAME AND TITLE: _____

INDICATE THE NAME AND CONTACT INFORMATION OF THE PERSON WHO CAN RESPOND AUTHORITATIVELY TO ANY QUESTIONS REGARDING THIS BID (I.E. PROJECT MANAGER):

NAME (PRINTED): _____ TEL. NO.: _____

E-MAIL ADDRESS: _____ FAX. NO.: _____

BID FORM, PAGE 5 OF 6

SUBMITTED BY: (LEGAL NAME OF FIRM)					
ADDRESS:					
CITY/STATE/ZIP:					
TELEPHONE NO:			FACSIMILE NO.:		
VA. CONTRACTOR LICENSE #:					
<p style="text-align: center;">THIS FIRM IS A: • INSERT NAME OF STATE _____ ___ CORPORATION, ___ GENERAL PARTNERSHIP, ___ LIMITED PARTNERSHIP, ___ UNINCORPORATED ASSOCIATION, ___ LIMITED LIABILITY COMPANY, ___ SOLE PROPRIETORSHIP</p>					
IS FIRM AUTHORIZED TO TRANSACT BUSINESS IN THE COMMONWEALTH OF VA?					
IDENTIFICATION NO. ISSUED TO THE FIRM BY THE SCC:					
ANY BIDDER EXEMPT FROM SCC AUTHORIZATION REQUIREMENT SHALL INCLUDE A STATEMENT WITH ITS BID WHY THEY ARE NOT REQUIRED TO BE SO AUTHORIZED					
IS YOUR FIRM CURRENTLY DEBARRED FROM SUBMITTING BIDS TO ARLINGTON COUNTY, VIRGINIA, OR ANY OTHER STATE OR POLITICAL SUBDIVISION?					
ENTITY'S DUN & BRADSTREET D-U-N-S NUMBER: <i>(if available)</i>					
BIDDER STATUS:	MINORITY OWNED:		WOMAN OWNED:		NEITHER:

INSURANCE CHECKLIST

CERTIFICATE OF INSURANCE MUST SHOW ALL COVERAGE AND ENDORSEMENTS MARKED "X".

COVERAGES REQUIRED

COVERAGE MINIMUM(S)

- X 1. Workers' Compensation Statutory limits of Virginia
X 2. Employer's Liability \$100,000 accident, \$100,000 disease, \$500,000 disease policy limit
X 3. Commercial General Liability \$1,000,000 CSL BI/PD each occurrence, \$2 Million annual aggregate
X 4. Premises/Operations \$500,000 CSL BI/PD each occurrence, \$1 Million annual aggregate
X 5. Automobile Liability \$1 Million BI/PD each accident, Uninsured Motorist
X6. Owned/Hired/Non-Owned Vehicles \$1 Million BI/PD each accident, Uninsured Motorist
X 7. Independent Contractors \$500,000 CSL BI/PD each occurrence, \$1 Million annual aggregate
__ 8. Products Liability \$500,000 CSL BI/PD each occurrence, \$1 Million annual aggregate
X 9. Completed Operations \$500,000 CSL BI/PD each occurrence, \$1 Million annual aggregate
X 10. Contractual Liability (Must be shown on Certificate) \$500,000 CSL BI/PD each occurrence, \$1 Million annual aggregate
__ 11. Personal and Advertising Injury Liability \$1 Million each offense, \$1 Million annual aggregate
X 12. Umbrella Liability \$1 Million Bodily Injury, Property Damage and Personal Injury
X 13. Per Project Aggregate
__ 14. Professional Liability
a. Architects and Engineers \$1 Million per occurrence/claim
b. Asbestos Removal Liability \$2 Million per occurrence/claim
c. Medical Malpractice \$1 Million per occurrence/claim
d. Medical Professional Liability \$ Limits as set forth in Virginia Code 8.01.581.15
__ 15. Miscellaneous E&O \$1 Million per occurrence/claim
__ 16. Motor Carrier Act End. (MCS-90) \$1 Million BI/PD each accident, Uninsured Motorist
__ 17. Motor Cargo Insurance
__ 18. Garage Liability \$1 Million Bodily Injury, Property Damage per occurrence
__ 19. Garage Keepers Liability \$500,000 Comprehensive, \$500,000 Collision
__ 20. Inland Marine-Bailee's Insurance \$
__ 21. Moving and Rigging Floater Endorsement to CGL
__ 22. Crime and Employee Dishonesty Coverage \$
X 23. Builder's Risk Provide Coverage in the full amount of Contract, including any amendments
__ 24. XCU Coverage Endorsement to CGL
__ 25. USL&H Federal Statutory Limits
X 26. Carrier Rating shall be A.M. Best Co.'s Rating of A-VII or better or equivalent
X 27. Notice of Cancellation, nonrenewal or material change in coverage shall be provided to County at least 30 days prior to action.
X 28. The County shall be an Additional Insured on all policies except Workers Compensation and Auto and Professional Liability.
X 29. Certificate of Insurance shall show Bid Number and Bid Title.
__ 30. OTHER INSURANCE REQUIRED: _____

INSURANCE AGENT'S STATEMENT:

I have reviewed the above requirements with the Bidder named below and have advised the Bidder of required coverages not provided through this agency.

AGENCY NAME: _____

AUTH. SIGNATURE: _____

BIDDER'S STATEMENT:

If awarded the Contract, I will comply with all Contract insurance requirements.

BIDDER NAME: _____

AUTH. SIGNATURE: _____

**ARLINGTON COUNTY, VIRGINIA
OFFICE OF THE PURCHASING AGENT**

INVITATION TO BID NO. 19-279-ITB

ADDENDUM A

Arlington County Invitation to Bid No. 19-279-ITB for CONSTRUCTION OF WET UTILITIES is amended as follows:

- I. Bid Due Date is postponed until **2:00PM on Tuesday, June 11, 2019.**
- II. The following Supplemental Specifications have been revised, with revisions uploaded to eVA as separate files:
 - SECTION 02901 COLORIZED BIKE LANE COATINGS
 - SECTION 13120 BOLLARDS
 - SECTION 02600 BITUMINOUS ROADWAY PAVEMENTS
- III. Drawings for "HDPE Connection to RCP" has been added (see question 21 below) and "Mulch and Mat Detail".
- IV. Attachment A "Pricing Sheet" has been revised and uploaded to eVA in response to some of the questions submitted below.
- V. The following questions were received:

1. General Excavation, The General Notes says it is incidental to the work. This is understood as it relates to the installation of pipe / structures. Is the contractor expected to include the excavation costs for all stone, concrete installation, asphalt installation, rip rap installation, retaining wall installation ect as part of those associated line items?

Response: All excavation shall be considered incidental to work. It shall be considered a subsidiary obligation of the contract under other work to which it relates, therefore, Yes, the contractor is expected to include excavation costs for all stone, concrete installation, asphalt installation, rip rap installation, retaining wall installation, etc. as part of those associated line items.

2. Bypass Pumping / Temporary Flow Diversion / Dewatering, The General Notes says it is incidental to the work. Given unknown nature of the contract, there is no way to accurately include costs when you cannot provide how much diversion / pumping is required or the conditions in which we will be required to work in. Will the County consider removing this incidental and accept pricing based on individual task orders once that information is available?

Response: Four sample projects were provided as examples in the solicitation as to the nature of the projects that will be constructed as a part of this contract. As per the special conditions of the contract, the cost of bypass pumping/temporary flow diversion/dewatering shall be incidental to other items in the contract.

3. Clearing & Grubbing, The General Notes say anything below 6" is incidental to the work. Given unknown nature of the contract, there is no way to accurately include costs when you cannot provide how often we will be required or the conditions in which we will be required to work in. Will the County consider adding an additional pay item Clearing & Grubbing (per Acre) for this scope of work?

Response: *The sample projects included in the solicitations shows the nature of the projects that will be constructed as a part of this contract. Per Section 02100, Part 4 – Measurement and Payment, Clearing and grubbing is considered to be a subsidiary obligation of the contract and, therefore, there will be no payment made for this work. Removal of any designated tree smaller than 6" DBH shall be considered clearing and shall be incidental to work.*

4. Item C1-3 Grading does not appear to have any specifications. What are the requirements included in item (removing dirt, replacing it, manipulating it ect). Please provide a measurement and payment specification.

Response: *Please see Section 02200 Earthwork specifications for the requirements of the grading. The line item cost includes grading to establish subgrades for walks, pavements, gravel surfaces and grassed areas. All areas covered by the project, including excavated and filled sections and adjacent transition areas, shall be uniformly smooth-graded. The finished surface shall be reasonably smooth, compacted, and free of irregular surface changes. Please include unit cost inclusive of all activities necessary to cover rough grading after cut/fill and fine grading of the flat and/or sloped surfaces.*

Per the pricing sheet grading shall be measured per SY.

5. Item C1-4 references Test Pits (Typically this is for locating existing utilities or conflicts) and References Test Bores (language typically utilized for taking small dia. borings to remove soils and test). Please clarify the intentions of these pay items.

Response: *Test pits and test bores (soil borings) line items separated. Pricing sheet revised accordingly.*

6. Item C1-7 Flowable Fill references a special provision from VDOT. Please provide the special provision referenced.

Response: *See link below:*

https://www.virginia.gov/business/resources/const/07RevDiv_III.pdf

7. Please Verify that the Geotextile for Rip Rap for items C1-22 through C1-28 are paid for under the Item C1-9 Geotextile for Rip Rap Bedding and not inclusive of individual rip-rap items.

Response: *Geotextile for Rip Rap for items C1-22 through C1-28 will be paid separately under line item C1-13 – Geotextile for Rip Rap bedding in place (VDOT Section 245.03.b) of the attached revised pricing sheet.*

8. Please Verify that the Excavation for Rip Rap for items C1-22 through C1-28 are paid for under the Item C1-1 Over Excavation and not inclusive of the individual rip-rap items.

Response: *Excavation for Rip Rap is incidental to individual RIPRAP items and will not be paid separately.*

9. Item C1-22 through C1-26 are Rip Rap Items Paid for in SY. What are the depth requirements for the rip rap under each item?

Response: See Section 414 – RIPRAP, of the VDOT Road and Bridge specs and Arlington County construction specs 02210 for the riprap classification.

10. Item C1-27 through C1-28 Reference Type 1 and 2 Rip Rap. The Quarries provide Rip Rap in Class A1, Class 1, Class 2, Class3. Does the Core Type Reference the Class (Ex. Type 1 = Class 1)? If not please provide the dimension requirements for Type 1 and 2 Core Rip Rap.

Response: See Section 414 – RIPRAP, of the VDOT Road and Bridge specs for the riprap classification. Dry RIPRAP is classified as Class I, Class II, etc. and Dumped RIPRAP is classified as Type I and Type II.

11. Item C2-16 References a Arlington County Standard H-3.1. The Current Standards (<https://topics.arlingtonva.us/wp-content/uploads/sites/21/2013/12/Construction-Standards-Details-9-30-13.pdf>) do not have an H-3.1. Where can we find this detail?

Response: See links below:

- <https://topics.arlingtonva.us/building/infrastructure-design-standards/>
- <https://topics.arlingtonva.us/wp-content/uploads/sites/21/2013/12/H-3.1-Driveway-Entrances.pdf>

12. Item C2-17 Concrete Pavers References Detail R2.1 On Detail R2.1 there are two options one with sand swept joints on stone base and the section option for mortared joints on concrete base. Which option are we supposed to be pricing on this bid.

Response: Please provide a price that will cover either option.

13. Item C2-18 Concrete Pavers Remove & Reset References Detail R2.1 Is the Contractor to remove and replace the stone base / concrete base and reset the pavers, or is this item strictly to remove and reset the pavers on the existing base?

Response: The line item should include price for removal and replacing the existing stone base/concrete base and resetting the existing pavers.

14. Item C2-20 Concrete Paver Crosswalk Remove & Reset References Detail R2.6 Is the Contractor to remove and replace the concrete base and reset the pavers, or is this item strictly to remove and reset the pavers on the existing base?

Response: Line item shall include removal and replacement of the existing concrete base and resetting existing pavers.

15. Item C3-9 through C3-12 for Imprinting / Stamping all reference Supplemental Spec 02600. The Supplemental Specification 02600 only provides reference to changing the Mixtures of Surface and Base Asphalt and fails to provide any information for the items in question. Please update Supplemental Spec 02600 and provide the necessary information for Imprinting / Stamping.

Response: Supplemental specs modified. See attached.

16. Item C3-15 references VDOT Standards PR-3 through PR-6. The VDOT Standards allow for options utilizing Rebar Reinforcement or Wiremesh Reinforcement. This should come from design from an individual task, which method is the contractor to utilize as there is a significant price difference?

Response: Provide price that will cover either option

17. Item C4-73 through C4-246 If field conditions do not allow for use of the compacted fill from the original trench to be utilized (ie bad materials or in VDOT ROW) will the contractor be compensated for the select fill utilizing C1 line items?

Response: The prices for installing all storm line items (pipes/culverts/structures) including the aforementioned line items now C4-73 through C4-238 of the revised pricing sheet attached, shall include compacted backfill. No separate payment shall be made for compacted back fill or select borrow.

18. Item C4-73 through C4-157 are they to be installed per Arlington Standards (#57 Stone Bedding with Compacted Backfill) or VDOT Standards (#25 Stone Bedding with Compacted Backfill)

Response: Provide price that will cover either option.

19. Storm Pipe Items (Various Line Items). There does not appear to be a CCTV Item Specific to the New Storm Drain Pipe Line Items. Is CCTV a requirement for these items, if so how is the contractor to be compensated for the CCTV.

Response: Cleaning and video inspection for storm pipes and sanitary pipes and manholes will be paid under line item # C4-348 and C4-349.

20. Storm Pipe + Structure Items (Various Line Items). Various Line Items for Storm Drainage Pipe Reference In Place, Depth <6' or Depth <6-8' for Example. How is this item measured. Example from existing surface , 6' to invert of pipe? 8' to bottom of Excavation?

Response: The measurement will be to the invert of the pipe. Excavation of the trench for pipe installation and the excavation of the bench on either side of the trench for pavement restoration shall be considered subsidiary obligation of the contract and incidental to the work. No additional payment will be made for the same.

21. Item C4-69 and Item C4-70 require core drilling of existing storm pipe for connection. Does the county have details/specifications for the PVC/HDPE Connection to the RCP Pipe?

Response: Pipe connection detail provided. See attachment.

22. Item C4-74 through C4-157 are they to be installed per Arlington Standards (#57 Stone Bedding with Compacted Backfill) or VDOT Standards (#25 Stone Bedding with Compacted Backfill)

Response: See response to question # 18 above.

23. Item C4-140 through C4-141 Reference 18" x 12" Elliptical Pipe. This size pipe is unavailable from Precast Manufacturers. Please remove this line item from the bid.

Response: Line items were changed to ARCH Pipe 18" x 11" (15" Equivalent, RCP Class III, In Place up to 6' deep, and ARCH Pipe 18" x 11" (15" Equivalent), RCP Class IV, In Place Up to 6' Deep respectively.

24. Item C4-158 through C4-185 Are for HDPE Storm Drainage, are they to be installed per Arlington Standards (#57 Stone Bedding under pipe and 2" up the side with Compacted Backfill) or VDOT Standards (Stone Bedding with Compacted Stone 1' above the pipe and then Compacted Backfill), or are we to follow the PE Pipe Design provided in the solicitation?

Response: HDPE storm pipe (C4-158 – C4-177 of the revised pricing sheet) shall be installed per VDOT standards.

25. Item C4-160 through C4-163 (14" + 16" HDPE) These Pipe Sizes for HDPE Do Not Existing. The Sizes in this range are 12", 15" and 18". Please Correct and remove the incorrect sizes from the bid form.

Response: Pricing sheet revised.

26. Item C4-170 through C4-173 (26" + 28" HDPE) These Pipe Sizes for HDPE Do Not Existing. The Sizes in this range are 24" and 30". Please Correct and remove the incorrect sizes from the bid form.

Response: Pricing sheet revised

27. Item C4-176 through C4-177 (32" HDPE) These Pipe Sizes for HDPE Do Not Existing. The Sizes in this range are 30" and 36". Please Correct and remove the incorrect sizes from the bid form.

Response: Pricing sheet revised

28. Items 02500-C4-03220 through 02500-C4-03400 (for Box Culverts) VDOT Pays the Pipe Bedding Separate from the Box Culverts. Is that the same case under this contract?

Response: For box culvert line items (C4-239 through C4-257 of the revised pricing sheet) pipe bedding shall be inclusive in the price for pipe under this contract. The price for box culverts shall include designing, casting, reinforcing, excavating, sheeting, shoring, dewatering, installing, waterproofing, sealing joints, anchoring, disposing of surplus and unsuitable material, restoring existing surfaces, bedding material, fittings, providing buffer zones, porous backfill and temporary stream relocation to facilitate the installation of the structure.

29. Item C4-247 through C4-265 (for Box Culverts) VDOT Pays the Excavation for Under Structure Excavation. There is no Structure Excavation under this contract, how is the excavation for box culverts being paid?

Response: For box culvert line items (C4-239 through C4-257 of the revised pricing sheet) all excavation shall be inclusive in the price for the pipe under this contract.

30. Item C4-247 through C4-265 (for Box Culverts) There are not pay items for Bypass Pumping or Stream Diversions, will this be an add change to the contract if required during the duration of the project?

Response: As per the special conditions of the contract, the cost of bypass pumping/temporary flow diversion/dewatering shall be incidental to other items in the contract.

31. Item C4-247 through C4-265 (for Box Culverts) VDOT Pays the Excavation for Porous Backfill. There is no Porous Backfill Item. Will this be paid for under the stone items in the contract?

Response: All backfill shall be inclusive in the unit prices for box culvert line items (C4-239 through C4-257 of the revised pricing sheet)

32. Item C4-247 through C4-265 (for Box Culverts) How is the contractor to be paid for the borrow material for backfill of the box culverts.

Response: The prices for the box culvert line items (C4-239 through C4-257 of the revised pricing sheet) shall include compacted backfill. No separate payment shall be made for compacted backfill or select borrow.

33. Item C4-247 through C4-265 (for Box Culverts) How is the contractor to be paid for headwalls required onto of the box culvert as it is not possible to incorporate into a LF price without knowing how many headwalls per LF are required.

Response: Headwalls will be paid separately for the box culvert line items (C4-239 through C4-257 of the revised pricing sheet)

34. Item C4-247 through C4-265 (for Box Culverts) How is the contractor to be paid for anchor walls required below of the box culvert as it is not possible to incorporate into a LF price without knowing how many anchor walls per LF are required.

Response: For box culvert line items (C4-239 through C4-257 of the revised pricing sheet), anchor wall and anchoring shall be inclusive in the price for the pipe under this contract.

35. Item C4-247 through C4-265 (for Box Culverts) is the rebar inclusive in this item or is it paid under items C2-28 through C2-30?

Response: For box culvert line items (C4-239 through C4-257 of the revised pricing sheet), reinforcing shall be inclusive in the price for the pipe under this contract.

36. Item C4-327 through C4-338 (Junction Boxes). These items are all paid for in VF. Since there are Frame & Covers also required (no pay item) should these not be paid similar to the Manholes where the first 8' is paid in Ea and then VF after 8' depth?

Response: Frame and Cover is considered inclusive for the junction boxes line items C4-319 through C4-330 of the revised pricing sheet.

37. Item C4-346 and C4-347 do not have a specified depth. Can you please specify the depth / height of structure range for these items.

Response: Please price the items C4-338 & C4-339 of the revised pricing sheet for the max. depth of 15'

38. Item C4-354 and C4-355 is the excavation to get to ditch grade paid for under item C-1 or considered incidental to this item?

Response: Excavation is incidental to the ditch pay items C-346 through C-347 and will not be paid separately.

39. Item C4-356 includes grading, however Grading does not appear to have any specifications. What are the requirements included in item (removing dirt, replacing it, manipulating it ect). Please provide a measurement and payment specification.

Response: *This line item (Sodded ditch including fine grading) has been deleted from C4. For grading requirements see response to question # 4*

40. Item C4-356 Appears to be the same line item as Item C13-26. The Items appears redundant, please clarify the difference between the two items.

Response: *This line item (Sodded ditch including fine grading) has been deleted from C4. See attached revised pricing sheet.*

41. Item C4-359 is for installation of Flowable fill in Storm Pipe. Will you please make this item into CY as this is how this item is typically paid. Also please clarify the difference between item C4-359 and item C1-7 as they appear to be the same item and redundant.

Response: *Please provide the price for C4-350 line item in the new pricing sheet, for abandoning the storm pipe in place inclusive of capping all open ends and filling the pipe with flowable fill. Please provide a unit price for flowable fill line item in C1-9 of the revised pricing sheet, for use as backfill material in new pipe installations or in other uses at locations as designated on the plans.*

42. How is the contractor to be compensated for removal of Storm Drainage Pipes?

Response: *Per County Specs Section 02500, Part 4, 4.1, sewer pipe unit cost shall include removal and disposal of existing pipes that are in conflict with the proposed pipes*

43. Item C6-1 through C6-22 how are the fittings (ie Bends, Tees, Crosses ect) for these pipe sizes to be paid for?

Response: *Please refer to the County Specs Section 02550, Part 4- Measurement and Payment, 4.1. The unit price of the water main line items shall include fittings.*

44. Item C6-87 through C6-91 are Casing Items that all Reference ID Dimensions. Casing Pipes are made to OD Dimensions and the sizes provided at ID are unavailable. Please correct the bid form to OD Dimensions.

Response: *Line items revised to state Nominal Pipe Size (NPS)*

45. Item C6-87 through C6-91 and Item C7-46 are Casing Items. Is the Excavation and Backfill of the Jacking and Receiving Pits inclusive of these items or are they paid for under the Excavation and Backfill items in the C1 Section of the Bid Form?

Response: *Excavation and Backfill of the Jacking and Receiving pits shall inclusive of line items C6-87 through C6-91.*

46. Item C6-108 for abandonment, does this item just require cut and cap of existing main for abandonment, or is the contractor expected to utilize flowable fill as well?

Response: *Please provide the price for C6-108 line item for abandoning the water main in place inclusive of capping all open ends and filling the pipe with flowable fill. Line item description revised on the pricing sheet.*

47. Will the contractor be paid for any water main requiring removal under item C6-108?

Response: Response: Per County Specs Section 02550, Part 4, 4.1, water main pipe unit cost shall include removal and disposal of existing pipes that are in conflict with the proposed pipe.

48. Item C7-1 through C7-45 If field conditions do not allow for use of the compacted fill from the original trench to be utilized (ie bad materials or in VDOT ROW) will the contractor be compensated for the select fill utilizing C1 line items?

Response: The prices for the aforementioned line items shall include compacted backfill. No separate payment shall be made for compacted backfill or select borrow.

49. Item C7-1 through C7-45 are they to be installed per Arlington Standards (#57 Stone Bedding with Compacted Backfill) or VDOT Standards (#25 Stone Bedding with Compacted Backfill)

Response: Provide price that will cover either option.

50. Sanitary Main and Structures (Various Line Items). Various Line Items for Sanitary Main Pipe and Structure Reference In Place, Depth <6' or Depth <6-8' for Example. How is this item measured. Example from existing surface, 6' to invert of pipe? 8' to bottom of Excavation?

Response: The measurement will be to the invert of the pipe. Excavation of the trench for pipe installation and the excavation of the bench on either side of the trench for pavement restoration shall be considered subsidiary obligation of the contract and incidental to the work. No additional payment will be made for the same.

51. Item C7-31 through C7-33 references 15" DIP. 15" DIP does not exist, the correct size is either 14" or 16", there are no odd sizes in this size DIP.

Response: Pricing sheet revised

52. Item C7-37 through C7-39 references 21" DIP. 21" DIP does not exist, the correct size is either 20" or 22", there are no odd sizes in this size DIP.

Response: Pricing sheet revised

53. How is the contractor to be compensated for removal or abandonment of sanitary main pipes?

Response: Abandoning of the sewer(storm/sanitary) pipe in place including capping all open ends and completely filling sewer with flowable fill will be compensated under line item C4-350. See revised pricing sheet.

Per County Specs Section 02500, Part 4, 4.1, sewer pipe unit cost shall include removal and disposal of existing pipes that are in conflict with the proposed pipes

54. Item C10-35 Reference Supplemental Spec 02901. No Supplemental Specification was included for Section 02901. Please provide the missing Supplemental Specification.

Response: Specs added. See addendum attachment

55. Item C10-43 and C10-48 both reference installation of signs on new posts. Are the posts to be installed per VDOT Standards with breakaway bases or per Arlington County Standards (U Channel Posts)

Response: Please provide the breakaway base square tube epoxy coated per VDOT standards.

56. How is the contractor to be compensated for removal and disposal of existing signs scheduled to be removed on a task order?

Response: Removal and disposal of existing signs shall be considered incidental to work. It shall be considered a subsidiary obligation of the contract under other work to which it relates.

57. Item C11-1 Appears to be the same line item as Item C11-15. The Items appears redundant, please clarify the difference between the two items.

Response: Redundant item removed. Pricing sheet revised.

58. Item C11-2 Appears to be the same line item as Item C11-16. The Items appears redundant, please clarify the difference between the two items.

Response: Redundant item removed. Pricing sheet revised.

59. Item C11-9 through C11-11 references various seed mixes. Please provide the Seed Mixes for review and provide the specification / location for these seed mix requirements.

Response: See Section 329200 – Seeding and Sodding of the Supplemental specs for the seed mixes.

60. Item C11-51 References Detail 311100.4 that does not provide dimensional requirements. It appears this item should be paid in CY not each based on the variables in the details that indicate referencing design plans that are not yet available.

Response: Unit changed to CY. Item # is C11- 49 in the revised pricing sheet

61. Item C11-54 has no detail or specifications to reference base requirements, or brick/paver requirements. Please provide specifications/details for this item.

Response: Pervious brick pavers bid item removed.

62. Item C11-55Brick Pavers Remove & Reset References Detail R2.1 Is the Contractor to remove and replace the stone base / concrete base and reset the pavers, or is this item strictly to remove and reset the pavers on the existing base?

Response: The Brick Pavers Remove and Reset line item (C11-52 of the revised pricing sheet) shall include removal and replacement of the existing stone/concrete base and resetting the pavers necessary to satisfy R2.1.

63. Item C11-56 Flagstone Walkway, Remove and Reset or Replace to Match Existing Is the Contractor to remove and replace the stone base / concrete base and reset the flagstone, or is this item strictly to remove and reset the pavers on the existing base?

Response: The line item (C11-53 of the revised pricing sheet) shall include removal and replacement of the existing stone/concrete base or bedding and resetting flagstone.

64. Item C11-57 Reference Supplemental Spec 13120. No Supplemental Specification was included for Section 13120. Please provide the missing Supplemental Specification.

Response: Supplemental specs provided. C11-54 of the revised pricing sheet.

65. Item C11-71 through C11-81 (Retaining Walls) What line items is the excavation for these walls to be paid for?

Response: The prices for all retaining wall line items in C-11 shall include excavation. No separate payment shall be made for excavation.

66. Item C11-71 through C11-81 (Retaining Walls) What line items are the porous backfill to be paid under?

Response: *The prices for all retaining wall line items in C-11 shall include backfill. No separate payment shall be made for compacted backfill or select borrow.*

67. Item C11-71 how is the stabilization stone backfill / geotextile matting to be paid?

Response: *For retaining wall line items in C-11, stabilization stone backfill/geotextile matting shall be included in the price of the line item. No separate payment shall be made.*

68. Item C11-82 are there any staining or sealing requirements with this item, or is this just for the form liner on the walls?

Response: *The rustication shall be in accordance with VDOT Road and Bridge Standard 401.03 for line item C11-79 of the revised pricing sheet.*

69. Item C13-1 Mulch/Mat Construction Entrance. No dimensional information or specification was referenced. Please provide document in which to base pricing on.

Response: *Mulch/Mat Construction entrance detail attached.*

70. Item C13-3 Has a payment of units is CY/TON. The Stone Conversion is not 1 CY/1 TON therefore the payment cannot be as listed. Please select either CY or TON and update the bid form accordingly.

Response: *C13-3 line item unit is in LF and is correct for that line item.*

71. Item C13-22 item description is contradictory Is this item for installation of seeded channels? Is excavation included in this item, if so what are the depths / widths required? Please provide a measurement and payment description for this item.

Response: *Pricing sheet revised. Please price the line item for the trapezoidal channels with bottom width between 4'-8', channel side-slopes of 3H:1V and depth between 3'-5'. Unit price shall include excavation, grading, lining and everything else necessary to install the grass channels per plans. Link to the design specs is:*

https://www.swbmp.vwrrc.vt.edu/wp-content/uploads/2017/11/BMP-Spec-No-3_GRASS-CHANNELS_v1-9_03012011.pdf

72. Item C13-23 through C13-24 items descriptions are contradictory. Are these items for installation of seeding or rip rap? Is excavation included in these items, if so what are the depths / widths required? Please provide a measurement and payment description for these items.

Response: *Line items deleted. Pricing sheet revised*

73. Item C13-25, item descriptions are contradictory. Are these items for installation of seeding or sod? Is excavation included in these items, if so what are the depths / widths required? Please provide a measurement and payment description for these items.

Response: *Line item deleted. Pricing sheet revised*

74. Item C13-27 through C13-28 items descriptions are contradictory. Are these items for installation of sod or rip rap? Is excavation included in these items, if so what are the depths / widths required? Please provide a measurement and payment description for these items.

Response: *Line items deleted. Pricing sheet revised*

75. Item C13-29 through C13-30. Items descriptions do not explain what is expected. Is the contractor excavating for rip rap or are we removing existing rip rap under this items. What are the depths / widths required? Please provide a measurement and payment description for these items.

Response: *Line item deleted. Pricing sheet revised.*

76. Item C13-34 references VESH Standard & Specification 3.22. That Standard referenced has not references to biologs with live stakes. Please clarify what is being referenced in the specification or provide correct specification / details and measurement and payment for this item.

Response: *Line item C13-34 or line item # C13-26 of the new pricing sheet, references DEQ Virginia Stream restoration and stabilization MBP guide and not Virginia Erosion and Sediment Control Handbook (VESCH) as stated in the question above. Biologs with live stakes stream protection shall be per Chapter 4, Section 2, Practice 2.1, Detail 2.1 and Practice 2.6, Detail 2.6. Unit price shall be inclusive of everything as shown in the detail. Link to the DEQ Virginia Stream restoration and stabilization MBP guide is:*

<https://www.deq.virginia.gov/Portals/0/DEQ/Water/Publications/BMPGuide.pdf>

Line item description revised to clarify further. See attached revised pricing sheet.

77. Item C13-39 References DEQ Chapter 4, Section 1, Practice 1.3, Detail 1.3. This VESH Chapter is in reference to stormwater runoff and is not applicable to the line item, and the Section 4, Practice 1.3, Detail 1.3 does not exist under this chapter. Please provide the correct reference documents.

Response: *C13-39 or line item # C13-31 of the new pricing sheet references DEQ Virginia Stream restoration and stabilization MBP guide and not Virginia Erosion and Sediment Control Handbook (VESCH) as stated in the question above. Please provide the unit price for this BMP inclusive of everything as shown in the detail. Link to the DEQ Virginia Stream restoration and stabilization MBP guide is:*

<https://www.deq.virginia.gov/Portals/0/DEQ/Water/Publications/BMPGuide.pdf>

78. Item C13-41 through C13-42 References DEQ Chapter 4, Section 5, Practice 5.1, Detail 5.1. This VESH Chapter is in reference to stormwater runoff and is not applicable to the line item, and the Section 5, Practice 5.1, Detail 5.1 does not exist under this chapter. Please provide the correct reference documents.

Response: *Line items deleted*

79. Item C13-41 through C13-42 how long is the contractor to provide bypass pumping under an each quantity. Please provide the missing measurement and payment specifications.

Response: *Line items deleted*

80. Item C13-43 through C13-44 References DEQ Chapter 4, Section 5, Practice 5.3, Detail 5.3. This VESH Chapter is in reference to stormwater runoff and is not applicable to the line item, and the Section 5, Practice 5.3, Detail 5.3 does not exist under this chapter. Please provide the correct reference documents.

Response: *Line items deleted*

81. Item C13-43 through C13-44 what is the size and length requirements for diversion piping? Please provide the missing measurement and payment specifications.

Response: *Line items deleted*

82. Item C13-45 References DEQ Chapter 4, Section 5, Practice 5.2, Detail 5.2. This VESH Chapter is in reference to stormwater runoff and is not applicable to the line item, and the Section 5, Practice 5.2, Detail 5.2 does not exist under this chapter. Please provide the correct reference documents.

Response: *Line item deleted*

83. Item C13-47 for EC-3 appears to be redundant. Item C13-46 and C13-48 cover the three types of EC-3 already.

Response: *Permanent soil stabilization mat pricing sheet line item #'s and descriptions revised. Line item C13-33 shall be per VDOT Road & Bridge Standard 113.05. Line item C13-34 shall be per VDOT Road & Bridge Standard 113.04. Line item C13-35 shall be per VDOT Road & Bridge Standard 113.03.*

84. Item C13-49 Appears to be the same line item as Item C13-50. The Items appears redundant, please clarify the difference between the two items.

Response: *Redundant Line item deleted.*

85. Item C15-6 and Item C15-31 both reference Pipe Layer by Hour. These items appears redundant, please clarify if they are the same item.

Response: *Redundant line items deleted.*

86. Item C15-16 and Item C15-38 both reference Air Compressor with Tools. These items appears redundant, please clarify if they are the same item.

Response: *Redundant line items deleted.*

87. Item C17-8 through C17-9 References DEQ Chapter 4, Section 3, Practice 4.4, Detail 4.4. This VESH Chapter is in reference to stormwater runoff and is not applicable to the line item, and the Section 3, Practice 4.4, Detail 4.4 does not exist under this chapter. Please provide the correct reference documents.

Response: *C17-8 through C17-9 references DEQ Virginia Stream restoration and stabilization MBP guide and not Virginia Erosion and Sediment Control Handbook (VESCH) as stated in the question above. Unit price shall be inclusive of everything. Link to the DEQ Virginia Stream*

restoration and stabilization MBP guide is:

<https://www.deq.virginia.gov/Portals/0/DEQ/Water/Publications/BMPGuide.pdf>

88. Traffic Control is listed as a percentage item. There does not appear to be a specific reference to barriers / attenuators under the line item. Are these expected to be installed under this item? If so will the county consider additional line items for these occurrences as without plans this requirement and greatly skew the % number received from contractors.

***Response:** Traffic control shall remain a percentage item per County specs Section 13180. There will be no additional compensation provided.*

89. Traffic Control is listed as a percentage item. There is no specific reference to Striping / Eradication of Existing markings. Is this a requirement of this item or is the temporary striping being paid under the striping items in the contract?

***Response:** Eradication of the existing marking shall be considered incidental to the work. Per County specs Section 02900, provision of temporary pavement markings is incidental to work and no additional compensation will be provided.*

90. The SWPPP Administration was not included under the percentage line items like previous bids. Will the county consider including this item for this contract?

***Response:** No separate payment will be made by the County for the SWPPP implementation. It shall be considered a subsidiary obligation under this contract. The Contractor shall **not** be entitled to any additional payment for changes to the SWPPP which are the result of the Contractor's work schedule or resource allocation, weather delays, or other factors not controlled by the County.*

The balance of the solicitation remains unchanged.

Arlington County, Virginia

Igor Scherbakov
Procurement Officer

RETURN THIS PAGE, FULLY COMPLETED AND SIGNED, WITH YOUR BID:

BIDDER ACKNOWLEDGES RECEIPT OF ADDENDUM A.

FIRM NAME: _____

AUTHORIZED SIGNATURE: _____ **DATE:** _____

PART 1 – GENERAL1.1 Description Of The Work

This work shall consist of furnishing and installing bollards in accordance with the Plans, and these Specifications, at the locations shown in the Plans or as staked by the Engineer.

PART 2 - MATERIALS2.1 Posts and Hardware

Bollards shall be semi-rigid flexible type model no DK-8 by U.S. Reflector or approved equal.

Bollards shall be a single piece design manufactured with polyurethane and UV inhibitors.

Bollards shall not feature springs or pivoting devices.

Bollards shall be 5.5-inches in diameter and shall have an overall installed height of 31-inches. Color shall be 'Steel'.

Bollards shall include two white reflective bands at the top.

Bollards shall feature a ring of reflective glass beads at the top and bottom of the post.

The Contractor shall include one anchor driver tool suitable for installation of the bollards.

2.3 Reflective Tape

Reflective tape shall be white and shall be one of the following or an approved equal:

Scotchlite High Intensity Grade Series 2870

Reflexite AP-1000

Scotchlite Diamond Grade LDP Series 3970

T-6500 High Intensity (Type IV)

2.4 Concrete

Footings shall be constructed using concrete Class 3000.

PART 3 – EXECUTION3.1 Construction Requirements

Bollards shall not vary more than 1/2 inch in 30 inches from a vertical plane.

Bollards shall be installed per the manufacture's recommendations.

PART 4 – MEASUREMENT AND PAYMENT

Measurement of bollards will be by the unit for each type of bollard furnished and installed.

Payment for bollards shall be per each and shall include all labor, materials, tools, equipment, transportation, supplies, and incidentals required to complete the work as specified. The anchor driver tool shall become property of the County at Contract

SECTION 02901:

COLORIZED BIKE LANE COATINGS

1. General Description: Colorized bike lane coating materials are pigmented waterborne coatings that combine color-fast acrylic resins and epoxy modification to provide long lasting, color stable roadway markings. Colorized coatings feature anti-slip properties designed to add friction for pedestrians and bicyclists without creating trip hazards. It has adhesion and flexibility properties that will not crack, peel or flake off the substrate. Colorized coatings are chemical resistant and are impervious to gas, oil and de-icing agents. Colorized coatings are recommended for long lane, no to low traffic delineation areas for preferential use, such as bike lane, bus lane, medians, no stopping areas and pedestrian zones.

2. Materials: Colorized coatings shall be composed of:

2.1. Coatings: A two component, epoxy-modified, acrylic, waterborne coating formulated to have a balance of properties that will ensure adhesion and movement on a flexible pavement, while providing excellent durability, color stability and friction properties.

Characteristics	Requirement
ASTM D2369 % Solids by weight	> 76%
ASTM D26297 % Solids by volume	> 55.5%
Weight per gallon	13.9 lbs/gal
% non-reactive fillers	< 40%
Boiling Range	147° -477°F
Vapor Density	Heavier than air
Flashpoint ASTM D 3278	>201°F
Hazardous Ingredients	none

2.2. Colorant: A concentrated, UV stable pigment blend designed to add the desired color to the coating. The coloring system shall consist of no less than 95% pure inorganic iron oxide pigments in a water-based liquid carrier. Pigment particle size (fineness) must pass 95% minus 325 mesh. Colorant must be alkali-resistant, water-insoluble, inert, light-resistant, inorganic, and lime-proof.

2.3. Material must be designed for application onto asphalt pavement surfaces but can be applied to non-bituminous concrete surfaces, such as Portland cement concrete, with use of a concrete primer.

2.4. Material shall be applied in 4 thin layers, allowing each layer to dry to the touch in between, to provide a total dry build thickness of 20-25 mils (0.51-0.635mm).

3. Application: Material shall be applied to the pavement surface using the methods outlined in the coating manufacturer’s application instructions.

3.1. Preconditions:

3.1.1. Surface Prep: The pavement surface shall be completely dry and free from all foreign matter. Concrete surfaces shall require additional surface preparation to remove any laitance from the surface. For concrete installations, a waterborne concrete primer, as recommended by manufacturer, shall be applied according to

application instructions and shall be allowed to dry to the touch before applying coatings. New asphalt surfaces shall be allowed to cool after final compaction roll to less than 140° F before applying coating.

3.1.2. Weather: Optimal installation temperatures are between 70-90F, with low humidity. Minimum air and substrate must be 50F and rising, and shall not drop below 50F within 8 hours of application of the last layer of coating. The temperature of the concrete or asphalt surface must be at least 5° F above the dew point temperature during and after applying coating. Increase in drying and curing times shall be expected at lower temperatures, and during high humidity. No precipitation shall be expected within 2 hours after the last layer of the coating is dry to the touch. Surfaces should be dry for at least 24 hours prior to applying colorized coatings. Coating application must be complete at least two hours before sunset to allow for proper cure.

3.1.3. Obstacles: Pavement markings that are to be left in place, utilities, drainage structures, curbs and any other structure within or adjacent to the treatment location shall be masked to protect from application. Existing pavement markings conflicting with the surface treatment should be removed by grinding or water blasting. Extra care should be taken to thoroughly remove residual dust and grinding debris.

3.2. Mixing: Part B, Colorant and 1 quart +/- 0.5 water shall be added to Part A and mixed thoroughly, creating a vortex, using a high speed high torque drill and paddle for a minimum of 3 minutes.

Application	
Mix Ratio (Coating) gal/pints	5 gal : 1 pint
Dry mil thickness per coat	10 to 15 mils
Recommended minimum number of coats	

3.3. Installation:

3.3.1. Initial Layer:

3.3.1.1.Small projects: Distribute initial layer of coatings to the pavement using a soft bristle broom and / or 1” - 1.5” nap roller. Ensure a thin build with even distribution.

3.3.1.2.Large or small projects: Each layer of coating application shall be spray applied using a double diaphragm spray system with an air atomized textured spray gun. Coatings shall be broomed using a soft bristle broom to work the material into the surface.

3.3.2. Additional Layers: The first layer and each additional layer of coating shall be allowed to dry to the touch before applying the next layer. The last layer shall be rolled, or spray and rolled, using a 1” – 1.5” nap roller to provide additional friction

properties. Environmental factors such as air and substrate temperature, humidity, sun and wind will affect dry times. Conditions that improve ability for moisture to evaporate will have positive effects on dry times.

3.3.3. Coverage: Coating material shall cover approximately 175 sq. ft. (16.3 m2) per mixed pail, using the recommended 4-layer system. While building the coating in layers, there will be less coverage with the first layer and greater coverage with subsequent layers.

3.4. Open to Traffic: Coating material shall be allowed to cure before being exposed to traffic. The longer they are allowed to cure, the better they will perform. Coatings shall be left for a minimum of 12 hours after the last layer is dry to the touch before traffic is introduced.

3.5. Clean up: Tooling and equipment shall be cleaned only with water while coatings are still wet. Remove masking. Dispose of all materials in accordance with all applicable federal, state and local laws and regulations.

4. Performance Properties

4.1. Key properties will include wear and crack resistance, color retention, adhesion, minimal softening from water absorption and anti-slip.

Test	Requirement
Dry Time (to re-coat) @ 50°F (10°C)	120 min
Dry Time (to re-coat) @ 90°F (32°C)	30 min
85% Cure (to permit Bike Lane) @ 50°F (10°C)	8 to 10 hours
85% Cure (to permit Traffic) @ 90°F (32°C)	4 to 6 hours
Gloss: ASTM D523 (60° Gardner)	2.5
Hardness: ASTM D3363	3H pencil
ASTM 2486 Gasoline Scrub Resistance To 50% of coating thickness (30 mils.)	>5000 cycles to max loss of 50% coating thickness
ASTM 2486 Motor Oil Scrub Resistance To 50% of coating thickness (30 mils)	>5000 cycles to max loss of 50% coating thickness
Temp. limits for service (of cured material) - 35°F to 145°F	-35°F to 145°F
ASTM G-155 Color Stability QUV 2,000 hrs (CIE units)	Old Brick Color $\Delta E < .5$
Pedestrian Friction ASTM E303 British Pendulum	88 BPN Dry 72 BPN Wet
Mandrel Bend Test ASTM D522	3/16" Pass
Water Absorption ASTM D570 7day	<9%
VOC Content ASTM D3960	<19 grams/liter
Taber Abrasion Dry H-10 ASTM D4060 1day cure	.17g/1000 cycles
Taber Abrasion Wet H-10 ASTM D4060 7day cure	.43g/1000 cycles

Adhesion to Asphalt ASTM D4541 >245 lb./sq.in	Asphalt Cohesive Failure
--	--------------------------

5. Field Quality Control

5.1. The contractor for work under this section shall maintain a quality control program specifically to verify compliance with this specification. A daily log shall be kept to record actions in the field. This log shall include the following information;

- Surface preparation start date and time
- Photos of surface prior to start of preparation
- Ambient temperature start and end of each day
- Relative humidity start and end of each day
- Substrate surface temperature start and end of each day

SECTION 02600

BITUMINOUS ROADWAY PAVEMENTS

This Section shall conform to the Arlington County Construction Standards and Specifications of Section 02600 except as modified herein.

Modify the following portions of Section 02600:

2.2 Base Course

Delete: The base course shall be bituminous concrete consisting of course and fine aggregate combined with asphalt cement, resulting in a mixture of Type BM-2 in conformance with Section 211 of the VDOT Specifications.

Add: The base course shall be bituminous concrete consisting of course and fine aggregate combined with asphalt cement, resulting in a mixture of Type BM-25.0A in conformance with Section 211 of the VDOT Specifications.

2.3 Surface Course

Delete: The surface course shall be bituminous concrete consisting of crushed stone, crushed slag, or crushed gravel and the fine aggregate, slag or stone screenings, or combination thereof, combined with asphalt, cement, resulting in a mixture of Type SM-2A in conformance with Section 211 of VDOT Specifications.

Add: The surface course shall be bituminous concrete consisting of crushed stone, crushed slag, or crushed gravel and the fine aggregate, slag or stone screenings, or combination thereof, combined with asphalt, cement, resulting in a mixture of Type SM-9.5A in conformance with Section 211 of VDOT Specifications.

2.5 Traffic Marking

Delete: Traffic marking will be provided by the County.

Add: Traffic marking will be provided by the Contractor.

2.6 Imprinting of Hot Mix Asphalt Concrete

Add: Imprinting operations shall begin immediately after hot asphalt has been placed and compacted to final density, while the asphalt is in a warm to hot pliable state or immediately after heating the asphalt. The Contractor shall follow the latest StreetPrint application procedures. Patterning shall be achieved using steel rollers and/or vibratory plate compactors and shall be of consistent depth. A European herringbone pattern shall be used, unless otherwise specified by the Project Officer. The cost of purchasing the pattern shall be borne by the Contractor. The Contractor shall receive approval for the pattern design from the Project Officer before performing any work. This work shall include imprinting new projects. Payment shall be made on the total square feet of imprint installed. Heating of the asphalt, if required, shall be covered as a separate pay item.

2.7 Heating Asphalt:

Add: Heating asphalt shall consist of using a reciprocating infrared heater specifically designed for heating asphalt safely. Asphalt shall be heated to a minimum depth of one inch (1") at a temperature not to exceed three hundred twenty-five degrees Fahrenheit (325°F). Heating asphalt is used for installing StreetPrint and DuraTherm. Payment shall be made on the total square feet of asphalt heated.

2.8 Provide and Install StreetBond coating

Add: StreetBond coatings shall be applied within five (5) days after imprinting the asphalt. The Contractor shall apply the "StreetBond Surfacing System" to the imprinted asphalt. The air temperature shall be at least fifty degrees Fahrenheit (50°F) prior to installation and be increasing through the application process in order to apply the StreetBond Surfacing System. There shall be no precipitation within twenty-four (24) hours after applying the coating. If precipitation occurs during the following twenty-four (24) hours and there is damage to the Streetbond coating, the Streetbond coating shall be reapplied at no additional expense to the City. Installation shall be in accordance with the latest StreetBond application procedures. The StreetBond products shall be spray applied and broomed to ensure that all voids in the pavement are coated. The Contractor shall apply a minimum of two (2) applications of StreetBond CemBase top coated with two (2) applications of StreetBond 150 coating. The entire surface shall be coated uniformly including the vertical edges of the imprinted surfaces. Sufficient masking shall be used to ensure that the surfacing products are applied only where specified. This work shall include the coating of new projects and the coating of existing imprinted surfaces where the old coating needs to be re-coated. Payment will be made on the total square feet of surface coated with four (4) coats of material, which shall include two (2) coats of CemBase and two (2) coats of StreetBond.

2.9 Imprinted Asphalt Patching:

Add: Imprinted asphalt patching shall include removing and replacing the requisite old asphalt and imprinting a new asphalt patch. The edges of the patch shall be feathered into the existing asphalt, providing a seamless surface between the patch and the surrounding asphalt. The imprinting shall be done so that the pattern in the patch matches the existing pattern on the surrounding asphalt. Payment will be made on the total square feet of asphalt patched.

NOTE: PIPE CONNECTION SHOULD BE ACCORDING TO MANUFACTURERS RECOMMENDATION.

NOTES:

1. - Connection and pipe to be backfilled per ASTM D2321.
2. - In lieu of an internal cylinder, an HDPE watertight repair coupler can be used to connect HDPE pipe to CMP.
3. - Internal cylinder adapter is not recommended for downstream connections.

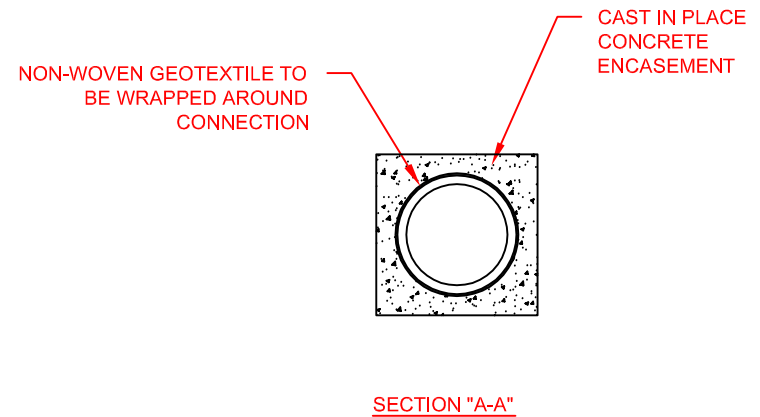
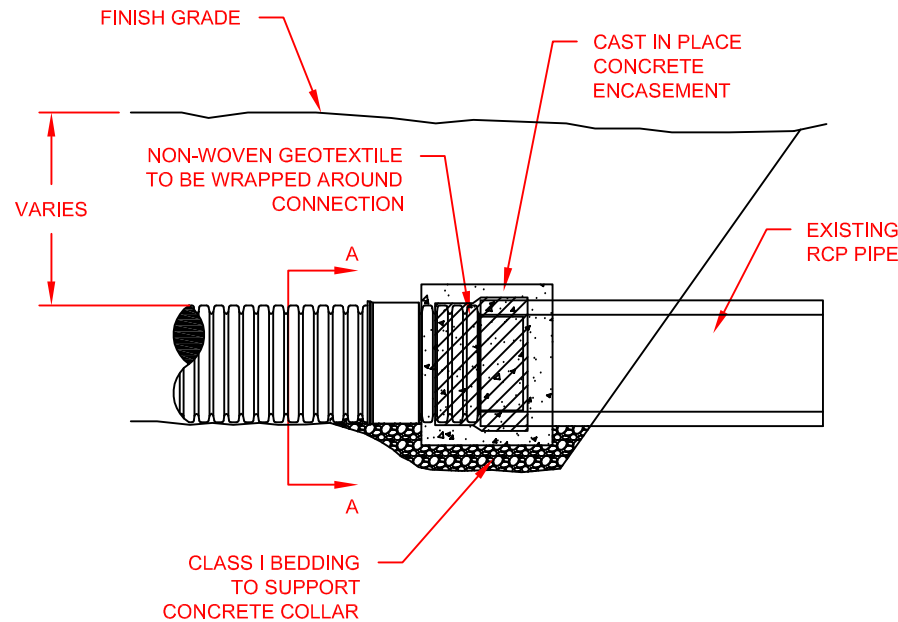
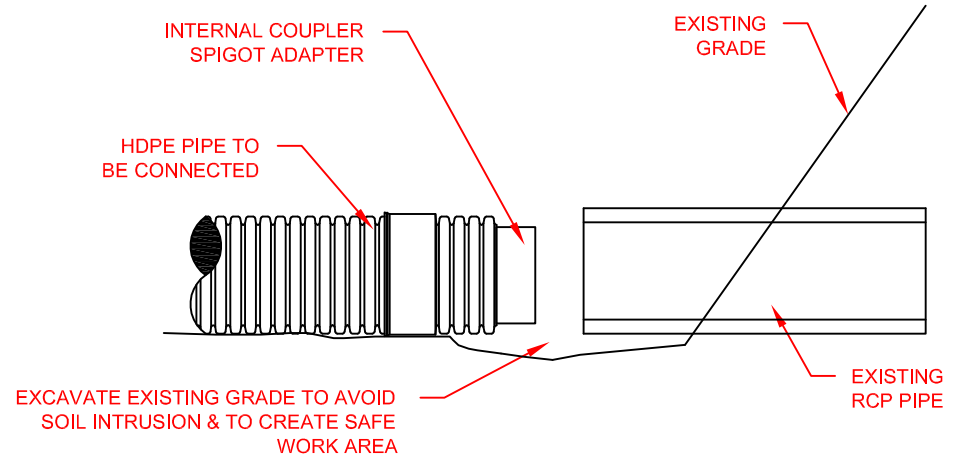

© 2007 ADS, INC.

ADVANCED DRAINAGE SYSTEMS, INC. ("ADS") HAS PREPARED THIS DETAIL BASED ON INFORMATION PROVIDED TO ADS. THIS DRAWING IS INTENDED TO DEPICT THE COMPONENTS AS REQUESTED. ADS HAS NOT PERFORMED ANY ENGINEERING OR DESIGN SERVICES FOR THIS PROJECT, NOR HAS ADS INDEPENDENTLY VERIFIED THE INFORMATION SUPPLIED. THE INSTALLATION DETAILS PROVIDED HEREIN ARE GENERAL RECOMMENDATIONS AND ARE NOT SPECIFIC FOR THIS PROJECT. THE DESIGN ENGINEER SHALL REVIEW THESE DETAILS PRIOR TO CONSTRUCTION. IT IS THE DESIGN ENGINEERS RESPONSIBILITY TO ENSURE THE DETAILS PROVIDED HEREIN MEETS OR EXCEEDS THE APPLICABLE NATIONAL, STATE, OR LOCAL REQUIREMENTS AND TO ENSURE THAT THE DETAILS PROVIDED HEREIN ARE ACCEPTABLE FOR THIS PROJECT.

1	UPDATED DRAWING	TJR	01/24/07	CKS
REV.	DESCRIPTION	BY	MM/DD/YY	CHK'D

DISSIMILAR PIPE CONNECTIONS FOR RCP DETAIL

DRAWING NUMBER: STD-603



4640 TRUEMAN BLVD
HILLIARD, OHIO 43026

ADVANCED DRAINAGE SYSTEMS, INC.

DRAWN BY:	K.J.M.
DATE:	
CHK'D BY:	
SCALE:	NTS
SHEET:	1 OF 1